

SUPPLEMENT

TO THE

FOURTH, FIFTH, AND SIXTH EDITIONS

OF THE

ENCYCLOPÆDIA BRITANNICA.

WITH PRELIMINARY DISSERTATIONS

ON THE

HISTORY OF THE SCIENCES.

Illustrated by Engravings.

VOLUME SECOND.

EDINBURGH:

PRINTED FOR ARCHIBALD CONSTABLE AND COMPANY, EDINBURGH;
AND HURST, ROBINSON, AND COMPANY,
LONDON.

1824.

AE

5

E56

1823

suppl.

v. 2

GEN. LIB.
HIST. ANTIQ
WALFORD
3-3 68
71.10-129
A21.101.

DISSERTATION SECOND:

EXHIBITING A GENERAL VIEW

OF THE

PROGRESS OF MATHEMATICAL AND PHYSICAL SCIENCE,

SINCE THE REVIVAL OF LETTERS IN EUROPE.

By JOHN PLAYFAIR,

**PROFESSOR OF NATURAL PHILOSOPHY IN THE UNIVERSITY OF EDINBURGH,
FELLOW OF THE ROYAL SOCIETY OF LONDON,
AND SECRETARY OF THE ROYAL SOCIETY OF EDINBURGH.**

DISSERTATION SECOND.

PART I.

IN conformity to the plan which has been traced and executed with so much ability in the First Dissertation, I am now to present the reader with an historical sketch of the principal discoveries made in Natural Philosophy, from the revival of letters down to the present time. In entering on this task, and on looking at the instructive but formidable model already set before me, I should experience no small solicitude, did I not trust that the subject of which I am to speak, in order to be interesting, needs only to be treated with clearness and precision. These two requisites I will endeavour to keep steadily in view.

In the order which I am to follow, I shall be guided solely by a regard to the subserviency of one science to the progress of another, and to the consequent priority of the former in the order of regular study. For this reason, the history of the pure Mathematics will be first considered, as that science has been one of the two principal instruments applied by the moderns to the advancement of natural knowledge. The other instrument is Experience; and, therefore, the principles of the inductive method, or of the branch of Logic which teaches the application of experiment and observation to the interpretation of nature, must be the second object of inquiry; and in this article I shall give an account of Bacon's Philosophy, as applied to Physical investigation. After these two sections, which may in some measure be considered as introductory, I am to treat of Na-

tural Philosophy, under the divisions of Mechanics, Astronomy, and Optics. Under the general denomination of Mechanics I include the Theory of Motion, as applied not only to solids, but to fluids, both incompressible and elastic. Optics I have placed after Astronomy, because the discoveries in Mechanics have much less affected the progress of the former of these sciences than of the latter. To these will succeed a sixth division, containing the laws of the three unknown substances, if, indeed, they may be called substances, —Heat, Electricity, and Magnetism. These, though very different, agree in some general characters. They permeate all substances, though not with the same facility; and, if other bodies had been formed in the same manner with them, the idea of impenetrability would never have been suggested to the mind. They seem to receive motion, without taking any away from the body which communicates it; so that they can hardly be considered as inert. Two of them, Heat and Electricity, are perceived by the sense of touch; but the impression which they make does not convey an idea of resistance. The third is not perceived by touch; and, therefore, all the three might be denominated impalpable substances. If they have any gravity, it cannot be appreciated; and, for these reasons, had it not too paradoxical an appearance, we might class them together as *material*, but *incorporeal* substances. We know, indeed, nothing of them but as powers, transferable from one body to another; and it is in consequence of this last circumstance alone that they are entitled to the name of substances.

Though the general design of this historical sketch extends from the revival of letters to the beginning of the nineteenth century, I shall, in the present Part, confine myself entirely, as has been done in the first Discourse, to the period preceding the end of the seventeenth century, or, more precisely, to that preceding the invention of the fluxionary calculus, and the discovery of the principle of gravitation;—one of the most remarkable epochs, without doubt, in the history of human knowledge.

SECTION I.

MATHEMATICS.

1. GEOMETRY.

THE great inheritance of mathematical knowledge which the ancients bequeathed to posterity could not, on the revival of learning, be immediately taken possession of, nor could even its existence be discovered, but by degrees. Though the study of the Mathematics

had never been entirely abandoned, it had been reduced to matters of very simple and easy comprehension, such as were merely subservient to practice. There had been men who could compute the area of a triangle, draw a meridian line, or even construct a sun-dial, in the worst of times; but between such skill, and the capacity to understand or the taste to relish, the demonstrations of Euclid, Apollonius, or Archimedes, there was a great interval, and many difficulties were to be overcome, for which much time, and much subsidiary knowledge, were necessary. The repositories of the ancient treasures were to be opened, and made accessible; the knowledge of the languages was to be acquired; the manuscripts were to be decyphered; and the skill of the grammarian and the critic were to precede, in a certain degree, that of the geometrician or the astronomer. The obligations which we have to those who undertook this laborious and irksome task, and who rescued the ancient books from the prisons to which ignorance and barbarism had condemned them, and from the final destruction by which they must soon have been overtaken, are such as we can never sufficiently acknowledge; and, indeed, we shall never know even the names of many of the benefactors to whom our thanks are due. In the midst of the wars, the confusion, and bloodshed, which overwhelmed Europe during the middle ages, the religious houses and monasteries afforded to the remains of ancient learning an asylum, which a salutary prejudice forced even the most lawless to respect; and the authors who have given the best account of the revival of letters, agree that it is in a great measure to those establishments that we owe the safety of the books which have kept alive the scientific and literary attainments of Greece and Rome.

The study of the remains of antiquity gradually produced men of taste and intelligence, who were able to correct the faults of the manuscripts they copied, and to explain the difficulties of the authors they translated. Such were Purbach, Regiomontanus, Commandine, Maurolycus, and many others. By their means, the writings of Euclid, Archimedes, Apollonius, Ptolemy, and Pappus, became known and accessible to men of science. Arabia contributed its share towards this great renovation, and from the language of that country was derived the knowledge of many Greek books, of the originals of which, some were not found till long afterwards, and others have never yet been discovered.

In nothing, perhaps, is the inventive and elegant genius of the Greeks better exemplified than in their geometry. The elementary truths of that science were connected by Euclid into one great chain, beginning from the axioms, and extending to the properties of the five regular solids; the whole digested into such admirable order, and explained with such clearness and precision, that no similar work of superior excellence has appeared, even in the present advanced state of mathematical science.

Archimedes had assailed the more difficult problems of geometry, and by means of the method of Exhaustions, had demonstrated many curious and important theorems, with regard to the lengths and areas of curves, and the contents of solids. The same great geometer had given a beginning to physico-mathematical science, by investigating several propositions, and resolving several problems in Mechanics and Hydrostatics.

Apollonius had treated of the Conic Sections,—the Curves which, after the circle, are the most simple and important in geometry; and, by his elaborate and profound researches, had laid the foundation of discoveries which were to illustrate very distant ages.

Another great invention, the Geometrical Analysis, ascribed very generally to the Platonic school, but most successfully cultivated by the geometer just named, is one of the most ingenious and beautiful contrivances in the mathematics. It is a method of discovering truth by reasoning concerning things unknown, or propositions merely supposed, as if the one were given, or the other were really true. A quantity that is unknown, is only to be found from the relations which it bears to quantities that are known. By reasoning on these relations, we come at last to some one so simple, that the thing sought is thereby determined. By this analytical process, therefore, the thing required is discovered, and we are at the same time put in possession of an instrument by which new truths may be found out, and which, when skill in using it has been acquired by practice, may be applied to an unlimited extent.

A similar process enables us to discover the demonstrations of propositions, supposed to be true, or, if not true, to discover that they are false.

This method, to the consideration of which we shall again have an opportunity of returning, was perhaps the most valuable part of the ancient mathematics, inasmuch as a method of discovering truth is more valuable than the truths it has already discovered. Unfortunately, however, the fragments containing this precious remnant had suffered more from the injuries of time than almost any other.

In the fifteenth century, Regiomontanus, already mentioned, is the mathematician who holds the highest rank. To him we owe many translations and commentaries, together with several original and valuable works of his own. Trigonometry, which had never been known to the Greeks as a separate science, and which took that form in Arabia, advanced, in the hands of Regiomontanus, to a great degree of perfection, and approached very near to the condition which it has attained at the present day. He also introduced the use of decimal fractions into arithmetic, and thereby gave to that scale its full extent, and to numerical computation the utmost degree of simplicity and enlargement which it seems capable of attaining.

This eminent man was cut off in the prime of life ; and his untimely death, says Mr Smith, amidst innumerable projects for the advancement of science, is even at this day a matter of regret.¹ He was buried in the Pantheon at Rome ; and the honours paid to him at his death prove that science had now become a distinction which the great were disposed to recognise.

Werner, who lived in the end of this century, is the first among the moderns who appears to have been acquainted with the geometrical analysis. His writings are very rare, and I have never had an opportunity of examining them. What I here assert is on the authority of Montucla, whose judgment in this matter may be safely relied on, as he has shown, by many instances, that he was well acquainted with the nature of the analysis referred to. It is not a little remarkable that Werner should have understood this subject, when we find many eminent mathematicians, long after his time, entirely unacquainted with it, and continually expressing their astonishment how the ancient geometers found out those simple and elegant constructions and demonstrations, of which they have given so many examples. In the days of Werner, there was no ancient book known except the *Data* of Euclid, from which any information concerning the geometrical analysis could be collected ; and it is highly to his credit, that, without any other help, he should have come to the knowledge of a method not a little recondite in its principles, and among the finest inventions either of ancient or of modern science. Werner resolved, by means of it, Archimedes's problem of cutting a sphere into two segments, having a given ratio to one another. He proposed also to translate, from the Arabic, the work of Apollonius, entitled *Sectio Rationis*, rightly judging it to be an elementary work in that analysis, and to come next after the *Data* of Euclid.²

Benedetto, an Italian mathematician, appears also to have been very early acquainted with the principles of the same ingenious method, as he published a book on the geometrical analysis at Turin in 1585.

Maurolycus of Messina flourished in the middle of the sixteenth century, and is justly regarded as the first geometer of that age. Beside furnishing many valuable translations and commentaries, he wrote a treatise on the conic sections, which is highly esteemed. He endeavoured also to restore the fifth book of the conics of Apollonius, in which that geometer treated of the *maxima* and *minima* of the conic sections. His writings all indicate

¹ *History of Astronomy*, p. 90. Regiomontanus was born in 1456, and died in 1496.

² See Montucla, Vol. I. p. 581.

a man of clear conceptions, and of a strong understanding ; though he is taxed with having dealt in astrological prediction.

In the early part of the seventeenth century, Cavalleri was particularly distinguished, and made an advance in the higher geometry, which occupies the middle place between the discoveries of Archimedes and those of Newton.

For the purpose of determining the lengths and areas of curves, and the contents of solids contained within curve superficies, the ancients had invented a method, to which the name of Exhaustions has been given ; and in nothing, perhaps, have they more displayed their powers of mathematical invention.

Whenever it is required to measure the space bounded by curve lines, the length of a curve, or the solid contained within a curve superficies, the investigation does not fall within the range of elementary geometry. Rectilineal figures are compared, on the principle of superposition, by help of the notion of equality which is derived from the coincidence of magnitudes both similar and equal. Two rectangles of equal bases and equal altitudes are held to be equal, because they can perfectly coincide. A rectangle and an oblique angled parallelogram, having equal bases and altitudes, are shown to be equal, because the same triangle, taken from the rectangle on one side, and added to it on the other, converts it into the parallelogram ; and thus two magnitudes which are not similar, are shown to have equal areas. In like manner, if a triangle and a parallelogram have the same base and altitude, the triangle is shown to be half the parallelogram ; because, if to the triangle there be added another, similar and equal to itself, but in the reverse position, the two together will compose a parallelogram, having the same base and altitude with the given triangle. The same is true of the comparison of all other rectilineal figures ; and if the reasoning be carefully analyzed, it will always be found to be reducible to the primitive and original idea of equality, derived from things that coincide or occupy the same space ; that is to say, the areas which are proved equal are always such as, by the addition or subtraction of equal and similar parts, may be rendered capable of coinciding with one another.

This principle, which is quite general with respect to rectilineal figures, must fail, when we would compare curvilinear and rectilineal spaces with one another, and make the latter serve as measures of the former, because no addition or subtraction of rectilineal figures can ever produce a figure which is curvilinear. It is possible, indeed, to combine curvilinear figures, so as to produce one that is rectilineal ; but this principle is of very limited extent ; it led to the quadrature of the *lunula* of Hippocrates, but has hardly furnished any other result which can be considered as valuable in science.

In the difficulty to which geometers were thus reduced, it might occur, that, by inscribing a rectilinear figure within a curve, and circumscribing another round it, two limits could be obtained, one greater and the other less than the area required. It was also evident, that, by increasing the number, and diminishing the sides of those figures, the two limits might be brought continually nearer to one another, and of course nearer to the curvilinear area, which was always intermediate between them. In prosecuting this sort of approximation, a result was at length found out, which must have occasioned no less surprise than delight to the mathematician who first encountered it. The result I mean is, that, when the series of inscribed figures was continually increased, by multiplying the number of the sides, and diminishing their size, there was an assignable *rectilinear* area, to which they continually approached, so as to come nearer it than any difference that could be supposed. The same limit would also be observed to belong to the circumscribed figures, and therefore it could be no other than the curvilinear area required.

It appears to have been to Archimedes that a truth of this sort first occurred, when he found that two-thirds of the rectangle, under the ordinate and abscissa of a parabola, was a limit always greater than the inscribed rectilinear figure, and less than the circumscribed. In some other curves, a similar conclusion was found, and Archimedes contrived to show that it was impossible to suppose that the area of the curve could differ from the said limit, without admitting that the circumscribed figure might become less, or the inscribed figure greater than the curve itself. The method of Exhaustions was the name given to the indirect demonstrations thus formed. Though few things more ingenious than this method have been devised, and though nothing could be more conclusive than the demonstrations resulting from it, yet it laboured under two very considerable defects. In the first place, the process by which the demonstration was obtained was long and difficult; and, in the second place, it was indirect, giving no insight into the principle on which the investigation was founded. Of consequence, it did not enable one to find out similar demonstrations, nor increase one's power of making more discoveries of the same kind. It was a demonstration purely synthetical, and required, as all indirect reasoning must do, that the conclusion should be known before the reasoning is begun. A more compendious, and a more analytical method, was therefore much to be wished for, and was an improvement, which, at a moment when the field of mathematical science was enlarging so fast, seemed particularly to be required.

Cavalleri, born at Milan in the year 1598, is the person by whom this great improvement was made. The principle on which he proceeded was, that areas may be considered as made up of an infinite number of parallel lines; solids of an infinite number of parallel

planes ; and even lines themselves, whether curve or straight, of an infinite number of points. The cubature of a solid being thus reduced to the summation of a series of planes, and the quadrature of a curve to the summation of a series of ordinates, each of the investigations was reduced to something more simple. It added to this simplicity not a little, that the sums of series are often more easily found, when the number of terms is infinitely great, than when it is finite, and actually assigned.

It appears that a tract on stereometry, written by Kepler, whose name will hereafter be often mentioned, first led Cavalleri to take this view of geometrical magnitudes. In that tract, which was published in 1615, the measurement of many solids was proposed, which had not before fallen under the consideration of mathematicians. Such, for example, was that of the solids generated by the revolution of a curve, not about its axis, but about any line whatsoever. Solids of that kind, on account of their affinity with the figure of casks, and vessels actually employed for containing liquids, appeared to Kepler to offer both curious and useful subjects of investigation. There were no less than eighty-four such solids, which he proposed for the consideration of mathematicians. He was, however, himself unequal to the task of resolving any but a small number of the simplest of these problems. In these solutions, he was bold enough to introduce into geometry, for the first time, the idea of infinitely great and infinitely small quantities, and by this apparent departure from the rigour of the science, he rendered it in fact a most essential service. Kepler conceived a circle to be composed of an infinite number of triangles, having their common vertex in the centre of the circle, and their infinitely small bases in the circumference. It is to be remarked, that Galileo had also introduced the notion of infinitely small quantities, in his first dialogue, *De Mechanica*, where he treats of a cylinder cut out of a hemisphere ; and he has done the same in treating of the acceleration of falling bodies. Cavalleri was the friend and disciple of Galileo, but much more profound in the mathematics. In his hands the idea took a more regular and systematic form, and was explained in his work on indivisibles, published in 1635.

The rule for summing an infinite series of terms in arithmetical progression had been long known, and the application of it to find the area of a triangle, according to the method of indivisibles, was a matter of no difficulty. The next step was, supposing a series of lines in arithmetical progression, and squares to be described on each of them, to find what ratio the sum of all these squares bears to the greatest square, taken as often as there are terms in the progression. Cavalleri showed, that when the number of terms is infinitely great, the first of these sums is just one-third of the second. This evidently led to the cubature of many solids.

Proceeding one step farther, he sought for the sum of the cubes of the same lines, and found it to be one-fourth of the greatest, taken as often as there are terms; and, continuing this investigation, he was able to assign the sum of the n th powers of a series in arithmetical progression, supposing always the difference of the terms to be infinitely small, and their number to be infinitely great. The number of curious results obtained from these investigations may be easily conceived. It gave, over geometrical problems of the higher class, the same power which the integral calculus, or the inverse method of fluxions does, in the case when the exponent of the variable quantity is an integer. The method of indivisibles, however, was not without difficulties, and could not but be liable to objection, with those accustomed to the rigorous exactness of the ancient geometry. In strictness, lines, however multiplied, can never make an area, or any thing but a line; nor can areas, however they may be added together, compose a solid, or any thing but an area. This is certainly true, and yet the conclusions of Cavalleri, deduced on a contrary supposition, are true also. This happened, because, though the suppositions that a certain series of lines, infinite in number, and contiguous to one another, may compose a certain area, and that another series may compose another area, are neither of them true; yet is it strictly true, that the one of these areas must have to the other the same ratio which the sum of the one series of lines has to the sum of the other series. Thus, it is the ratios of the areas, and not the areas absolutely considered, which are determined by the reasonings of Cavalleri; and that this determination of their ratios is quite accurate, can very readily be demonstrated by the method of exhaustions.

The method of indivisibles, from the great facility with which it could be managed, furnished a most ready method of ascertaining the ratios of areas and solids to one another, and, therefore, scarcely seems to deserve the epithet which Newton himself bestows upon it, of involving in its conceptions something harsh; (*durum*,) and not easy to be admitted. It was the doctrine of infinitely small quantities carried to the extreme, and gave at once the result of an infinite series of successive approximations. Nothing, perhaps, more ingenious, and certainly nothing more happy, ever was contrived, than to arrive at the conclusion of all these approximations, without going through the approximations themselves. This is the purpose served by introducing into mathematics the consideration of quantities infinitely small in size, and infinitely great in number; ideas which, however inaccurate they may seem, yet, when carefully and analogically reasoned upon, have never led into error.

Geometry owes to Cavalleri, not only the general method just described, but many particular theorems, which that method was the instrument of discovering. Among these is

the very remarkable proposition, *that as four right angles, to the excess of the three angles of any spherical triangle, above two right angles, so is the superficies of the hemisphere to the area of the triangle.* At that time, however, science was advancing so fast, and the human mind was everywhere expanding itself with so much energy, that the same discovery was likely to be made by more individuals than one at the same time. It was not known in Italy in 1632, when this determination of the area of a spherical triangle was given by Cavalleri, that it had been published three years before by Albert Girard, a mathematician of the Low Countries, of whose inventive powers we shall soon have more occasion to speak.

The Cycloid afforded a number of problems, well calculated to exercise the proficient in the geometry of indivisibles, or of infinites. It is the curve described by a point in the circumference of a circle, while the circle itself rolls in a straight line along a plane. It is not quite certain when this curve, so remarkable for its curious properties, and for the place which it occupies in the history of geometry, first drew the attention of mathematicians. In the year 1639, Galileo informed his friend Torricelli, that, forty years before that time, he had thought of this curve, on account of its shape, and the graceful form it would give to arches in architecture. The same philosopher had endeavoured to find the area of the cycloid; but though he was one of those who first introduced the consideration of infinites into geometry, he was not expert enough in the use of that doctrine, to be able to resolve this problem. It is still more extraordinary, that the same problem proved too difficult for Cavalleri, though he certainly was in complete possession of the principles by which it was to be resolved. It is, however, not easy to determine whether it be Torricelli, the scholar of Cavalleri, and his successor in genius and talents, or to Roberval, a French mathematician of the same period, and a man also of great originality and invention, that science is indebted for the first quadrature of the cycloid, or the proof that its area is three times that of its generating circle. Both these mathematicians laid claim to it. The French and Italians each took the part of their own countryman; and in their zeal have so perplexed the question, that it is hard to say on which side the truth is to be found. Torricelli, however, was a man of a mild, amiable, and candid disposition; Roberval of a temper irritable, violent, and envious; so that, in as far as the testimony of the individuals themselves is concerned, there is no doubt which ought to preponderate. They had both the skill and talent which fitted them for this, or even for more difficult researches.

The other properties of this curve, those that respect its tangents, its length, its curvature, &c. exercised the ingenuity, not only of the geometers just mentioned, but of Wren,

Wallis, Huygens, and, even after the invention of the integral calculus, of Newton, Leibnitz, and Bernoulli.

Roberval also improved the method of quadratures invented by Cavalleri, and extended his solutions to the case, when the powers of the terms in the arithmetical progression of which the sum was to be found were fractional; and Wallis added the case when they were negative. Fermat, who, in his inventive resources, as well as in the correctness of his mathematical taste,¹ yielded to none of his contemporaries, applied the consideration of infinitely small quantities to determine the *maxima* and *minima* of the ordinates of curves, as also their tangents. Barrow, somewhat later, did the same in England. Afterwards the geometry of infinites fell into the hands of Leibnitz and Newton, and acquired that new character which marks so distinguished an era in the mathematical sciences.

2. ALGEBRA.

It was not from Greece alone that the light proceeded which dispelled the darkness of the middle ages; for, with the first dawn of that light, a mathematical science, of a name and character unknown to the geometers of antiquity, was received in Europe from Arabia. As early as the beginning of the thirteenth century, Leonardo, a merchant of Pisa, having made frequent visits to the East, in the course of commercial adventure, returned to Italy enriched by the traffic, and instructed by the science of those countries. He brought with him the knowledge of *Algebra*; and a late writer quotes a manuscript of his, bearing the date of 1202, and another that of 1228.² The importation of *Algebra* into Europe is thus carried back nearly 200 years farther than has generally been supposed, for Leonardo has been represented as flourishing in the end of the fourteenth century, instead of the very beginning of the thirteenth. It appears by an extract from his manuscript, published by the above author, that his knowledge of *Algebra* extended as far as quadratic equations. The language was very imperfect, corresponding to the infancy of the science; the quantities and the operations being expressed in words, with the help only of a few abbreviations. The rule for resolving quadratics by completing the square, is demonstrated geometrically.

Though *Algebra* was brought into Europe from Arabia, it is by no means certain that

¹ He also was very skilful in the geometric analysis, and seems to have more thoroughly imbibed the spirit of that ingenious invention than any of the moderns before Halley.

² M. Cossali of Pisa, in a Tract on the Origin of *Algebra*, 1797.

this last is its native country. There is, indeed, reason to think that its invention must be sought for much farther to the East, and probably not nearer than Indostan. We are assured by the Arabian writers, that Mahomet Ben Musa of Chorasán, distinguished for his mathematical knowledge, travelled, about the year 959, into India, for the purpose of receiving farther instruction in the science which he cultivated. It is likewise certain, that some books, which have lately been brought from India into this country, treat of algebra in a manner that has every appearance of originality, or at least of being derived from no source with which we are at all acquainted.

Before the time of Leonardo of Pisa, an important acquisition, also from the East, had greatly improved the science of arithmetic. This was the use of the Arabic notation, and the contrivance of making the same character change its signification, according to a fixed rule, when it changed its position, being increased tenfold for every place that it advanced towards the left. The knowledge of this simple but refined artifice was learned from the Moors by Gerbert, a monk of the Low Countries, in the tenth century, and by him made known in Europe. Gerbert was afterwards Pope, by the name of Silvester the Second; but from that high dignity derived much less glory than from having instructed his countrymen in the decimal notation.

The writings of Leonardo, above mentioned, have remained in manuscript; and the first printed book in Algebra is that of Lucas de Burgo, a Franciscan, who, towards the end of the fifteenth century, travelled, like Leonardo, into the East, and was there instructed in the principles of algebra. The characters employed in his work, as in those of Leonardo, are mere abbreviations of words. The letters *p* and *m* denote *plus* and *minus*; and the rule is laid down, that, in multiplication, *plus* into *minus* gives *minus*, but *minus* into *minus* gives *plus*. Thus the first appearance of Algebra is merely that of a system of short-hand writing, or an abbreviation of common language, applied to the solution of arithmetical problems. It was a contrivance merely to save trouble; and yet to this contrivance we are indebted for the most philosophical and refined art which men have yet employed for the expression of their thoughts. This scientific language, therefore, like those in common use, has grown up slowly, from a very weak and imperfect state, till it has reached the condition in which it is now found.

Though in all this the moderns received none of their information from the Greeks, yet a work in the Greek language, treating of arithmetical questions, in a manner that may be accounted algebraic, was discovered in the course of the next century, and given to the world, in a Latin translation, by Xylander, in 1575. This is the work of Diophantus of Alexandria, who had composed thirteen books of Arithmetical Questions, and is sup-

posed to have flourished about 150 years after the Christian era. The questions he resolves are often of considerable difficulty; and a great deal of address is displayed in stating them, so as to bring out equations of such a form, as to involve only one power of the unknown quantity. The expression is that of common language, abbreviated and assisted by a few symbols. The investigations do not extend beyond quadratic equations; they are, however, extremely ingenious, and prove the author to have been a man of talent, though the instrument he worked with was weak and imperfect.

The name of Cardan is famous in the history of Algebra. He was born at Milan in 1501, and was a man in whose character good and ill, strength and weakness, were mixed up in singular profusion. With great talents and industry, he was capricious, insincere, and vain-glorious to excess. Though a man of real science, he professed divination, and was such a believer in the influence of the stars, that he died to accomplish an astrological prediction. He remains, accordingly, a melancholy proof, that there is no folly or weakness too great to be united to high intellectual attainments.

Before his time very little advance had been made in the solution of any equations higher than the second degree; except that, as we are told, about the year 1508, Scipio Ferrei, professor of mathematics at Bologna, had found out a rule for resolving one of the cases of cubic equations, which, however, he concealed, or communicated only to a few of his scholars. One of these, Florido, on the strength of the secret he possessed, agreeably to a practice then common among mathematicians, challenged Tartalea of Brescia, to contend with him in the solution of algebraic problems. Florido had at first the advantage; but Tartalea, being a man of ingenuity, soon discovered his rule, and also another much more general, in consequence of which, he came off at last victorious. By the report of this victory, the curiosity of Cardan was strongly excited; for, though he was himself much versed in the mathematics, he had not been able to discover a method of resolving equations higher than the second degree. By the most earnest and importunate solicitation, he wrung from Tartalea the secret of his rules, but not till he had bound himself, by promises and oaths, never to divulge them. Tartalea did not communicate the demonstrations, which, however, Cardan soon found out, and extended, in a very ingenious and systematic manner, to all cubic equations whatsoever. Thus possessed of an important discovery, which was at least in a great part his own, he soon forgot his promises to Tartalea, and published the whole in 1545, not concealing, however, what he owed to the latter. Though a proceeding, so directly contrary to an express stipulation, cannot be defended, one does not much regret the disappointment of any man who would make a mystery of knowledge, or keep his discoveries a secret, for purposes merely selfish.

Thus was first published the rule which still bears the name of Cardan, and which, at this day, marks a point in the progress of algebraic investigation, which all the efforts of succeeding analysts have hardly been able to go beyond. As to the general doctrine of equations, it appears that Cardan was acquainted both with the negative and positive roots, the former of which he called by the name of false roots. He also knew that the number of positive, or, as he called them, true roots, is equal to the number of the changes of the signs of the terms; and that the coefficient of the second term is the difference between the sum of the true and the false roots. He also had perceived the difficulty of that case of cubic equations, which cannot be reduced to his own rule. He was not able to overcome the difficulty, but showed how, in all cases, an approximation to the roots might be obtained.

There is the more merit in these discoveries, that the language of Algebra still remained very imperfect, and consisted merely of abbreviations of words. Mathematicians were then in the practice of putting their rules into verse. Cardan has given his a poetical dress, in which, as may be supposed, they are very awkward and obscure; for whatever assistance in this way is given to the memory, must be entirely at the expence of the understanding. It is, at the same time, a proof that the language of Algebra was very imperfect. Nobody now thinks of translating an algebraic formula into verse; because, if one has acquired any familiarity with the language of the science, the formula will be more easily remembered than any thing that can be substituted in its room.

Italy was not the only country into which the algebraic analysis had by this time found its way; in Germany it had also made considerable progress, and Stiphelius, in a book of Algebra, published at Nuremberg in 1544, employed the same numeral exponents of powers, both positive and negative, which we now use, as far as integer numbers are concerned; but he did not carry the solution of equations farther than the second degree. He introduced the same characters for *plus* and *minus* which are at present employed.

Robert Recorde, an English mathematician, published about this time, or a few years later, the first English treatise on Algebra, and he there introduced the same sign of equality which is now in use.

The properties of algebraic equations were discovered, however, very slowly. Pelitarius, a French mathematician, in a treatise which bears the date of 1558, is the first who observed that the root of an equation is a divisor of the last term; and he remarked also this curious property of numbers, that the sum of the cubes of the natural numbers is the square of the sum of the numbers themselves.

The knowledge of the solution of cubic equations was still confined to Italy. Bombelli,

a mathematician of that country, gave a regular treatise on Algebra, and considered, with very particular attention, the irreducible case of Cardan's rule. He was the first who made the remark, that the problems belonging to that case can always be resolved by the trisection of an arch.¹

Vieta was a very learned man, and an excellent mathematician, remarkable both for industry and invention. He was the first who employed letters to denote the known as well as the unknown quantities, so that it was with him that the language of algebra first became capable of expressing general truths, and attained to that extension which has since rendered it such a powerful instrument of investigation. He has also given new demonstrations of the rule for resolving cubic, and even biquadratic equations. He also discovered the relation between the roots of an equation of any degree, and the coefficients of its terms, though only in the case where none of the terms are wanting, and where all the roots are real or positive. It is, indeed, extremely curious to remark, how gradually the truths of this sort came in sight. This proposition belonged to a general truth, the greater part of which remained yet to be discovered. Vieta's treatises were originally published about the year 1600, and were afterwards collected into one volume by Schooten, in 1646.

In speaking of this illustrious man, Vieta, we must not omit his improvements in trigonometry, and still less his treatise on angular sections, which was a most important application of Algebra to investigate the theorems, and resolve the problems of geometry. He also restored some of the books of Apollonius, in a manner highly creditable to his own ingenuity, but not perfectly in the taste of the Greek geometry; because, though the constructions are elegant, the demonstrations are all synthetical.

About the same period, Algebra became greatly indebted to Albert Girard, a Flemish mathematician, whose principal work, *Invention Nouvelle en Algebra*, was printed

¹ A passage in Bombelli's book, relative to the Algebra of India, has become more interesting, from the information concerning the science of that country, which has reached Europe within the last twenty years. He tells us, that he had seen in the Vatican library, a manuscript of a certain Diophantus, a Greek author, which he admired so much, that he had formed the design of translating it. He adds, that in this manuscript he had found the Indian authors often quoted; from which it appeared, that Algebra was known to the Indians before it was known to the Arabians. Nothing, however, of all this is to be found in the work of Diophantus, which was published about three years after the time when Bombelli wrote. As it is, at the same time, impossible that he could be so much mistaken about a manuscript which he had particularly examined, this passage remains a mystery, which those who are curious about the ancient history of science would be very glad to have unravelled. See Hutton's *History of Algebra*.

in 1669. This ingenious author perceived a greater extent, but not yet the whole of the truth, partially discovered by Vieta, viz. the successive formation of the coefficients of an equation from the sum of the roots; the sum of their products taken two and two; the same taken three and three, &c. whether the roots be positive or negative. He appears also to have been the first who understood the use of negative roots in the solution of geometrical problems, and is the author of the figurative expression, which gives to negative quantities the name of *quantities less than nothing*; a phrase that has been severely censured by those who forget that there are correct ideas, which correct language can hardly be made to express. The same mathematician conceived the notion of imaginary roots, and showed that the number of the roots of an equation could not exceed the exponent of the highest power of the unknown quantity. He was also in possession of the very refined and difficult rule, which forms the sums of the powers of the roots of an equation from the coefficients of its terms. This is the greatest list of discoveries which the history of any algebraist could yet furnish.

The person next in order, as an inventor in Algebra, is Thomas Harriot, an English mathematician, whose book, *Artis Analyticæ Praxis*, was published after his death, in 1631. This book contains the genesis of all equations, by the continued multiplication of simple equations; that is to say, it explains the truth in its full extent, to which Vieta and Girard had been approximating. By Harriot also, the method of extracting the roots of equations was greatly improved; the smaller letters of the alphabet, instead of the capital letters employed by Vieta, were introduced; and by this improvement, trifling, indeed, compared with the rest, the form and exterior of algebraic expression were brought nearer to those which are now in use.

I have been the more careful to note very particularly the degrees by which the properties of equations were thus unfolded, because I think it forms an instance hardly paralleled in science, where a succession of able men, without going wrong, advanced, nevertheless, so slowly in the discovery of a truth which, when known, does not seem to be of a very hidden and abstruse nature. Their slow progress arose from this, that they worked with an instrument, the use of which they did not fully comprehend, and employed a language which expressed more than they were prepared to understand;—a language which, under the notion, first of negative and then of imaginary quantities, seemed to involve such mysteries as the accuracy of mathematical science must necessarily refuse to admit.

The distinguished author of whom I have just been speaking was born at Oxford in 1560. He was employed in the second expedition sent out by Sir Walter Raleigh to Vir-

ginia, and on his return published an account of that country. He afterwards devoted himself entirely to the study of the mathematics; and it appears from some of his manuscripts, lately discovered, that he observed the spots of the sun as early as December 1610, not more than a month later than Galileo. He also made observations on Jupiter's satellites, and on the comets of 1607, and of 1618.¹

The succession of discoveries, above related, brought the algebraic analysis, abstractly considered, into a state of perfection, little short of that which it has attained at the present moment. It was thus prepared for the step which was about to be taken by Descartes, and which forms one of the most important epochs in the history of the mathematical sciences. This was the application of the algebraic analysis, to define the nature, and investigate the properties, of curve lines, and, consequently, to represent the notion of variable quantity. It is often said, that Descartes was the first who applied algebra to geometry; but this is inaccurate; for such applications had been made before, particularly by Vieta, in his treatise on angular sections. The invention just mentioned is the undisputed property of Descartes, and opened up vast fields of discovery for those who were to come after him.

The work in which this was contained is a tract of no more than 106 quarto pages; and there is probably no book of the same size which has conferred so much and so just celebrity on its author. It was first published in 1637.

In the first of the three books into which the tract just mentioned is divided, the author begins with the consideration of such geometrical problems as may be resolved by circles and straight lines; and explains the method of constructing algebraic formulas, or of translating a truth from the language of algebra into that of geometry. He then proceeds to the consideration of the problem, known among the ancients by the name of the *locus ad quatuor rectas*, and treated of by Apollonius and Pappus. The algebraic analysis afforded a method of resolving this problem in its full extent; and the consideration of it is again resumed in the second book. The thing required is, to find the locus of a point, from which, if perpendiculars be drawn to four lines given in position, a given function of these perpendiculars, in which the variable quantities are only of two dimen-

¹ The manuscripts which contain these observations, and probably many other things of great interest, are preserved in the collection of the Earl of Egremont, having come into the possession of his family from Henry Percy Earl of Northumberland, a most liberal patron of science, with whom Harriot appears to have chiefly lived after his return from Virginia

sions, shall be always of the same magnitude.¹ Descartes shows the locus, on this hypothesis, to be always a conic section; and he distinguishes the cases in which it is a circle, an ellipsis, a parabola, or a hyperbola. It was an instance of the most extensive investigation which had yet been undertaken in geometry, though, to render it a complete solution of the problem, much more detail was doubtless necessary. The investigation is extended to the cases where the function, which remains the same, is of three, four, or five dimensions, and where the locus is a line of a higher order, though it may, in certain circumstances, become a conic section. The lines given in position may be more than four, or than any given number; and the lines drawn to them may either be perpendiculars, or lines making given angles with them. The same analysis applies to all the cases; and this problem, therefore, afforded an excellent example of the use of algebra in the investigation of geometrical propositions. The author takes notice of the unwillingness of the ancients to transfer the language of arithmetic into geometry, so that they were forced to have recourse to very circuitous methods of expressing those relations of quantity in which powers beyond the third are introduced. Indeed, to deliver investigation from those modes of expression which involve the composition of ratios, and to substitute in their room the multiplication of the numerical measures, is of itself a very great advantage, arising from the introduction of algebra into geometry.

In this book also, an ingenious method of drawing tangents to curves is proposed by Descartes, as following from his general principles, and it is an invention with which he appears to have been particularly pleased. He says, “Nec verebor dicere problema hoc non modo eorum, quæ scio, utilissimum et generalissimum esse, sed etiam eorum quæ in geometria scire unquam desideraverim.”² This passage is not a little characteristic of Descartes, who was very much disposed to think well of what he had done himself, and even to suppose that it could not easily be rendered more perfect. The truth, however, is, that his method of drawing tangents is extremely operose, and is one of those hasty views which, though ingenious and even profound, require to be vastly simplified, before they can be reduced to practice. Fermat, the rival and sometimes the superior of Descartes, was far more fortunate with regard to this problem, and his method of drawing tangents to curves, is the same in effect that has been followed by all the geometers since

¹ It will easily be perceived, that the word *function* is not contained in the original enunciation of the problem. It is a term but lately introduced into mathematical language, and affords here, as on many other occasions, a more general and more concise expression than could be otherwise obtained.

² Cartesii Geometria, p. 40.

his time,—while that of Descartes, which could only be valued when the other was unknown, has been long since entirely abandoned. The remainder of the second book is occupied with the consideration of the curves, which have been called the ovals of Descartes, and with some investigations concerning the centres of lenses ; the whole indicating the hand of a great master, and deserving the most diligent study of those who would become acquainted with this great enlargement of mathematical science.

The third book of the geometry treats of the construction of equations by geometric curves, and it also contains a new method of resolving biquadratic equations.

The leading principles of algebra were now unfolded, and the notation was brought, from a mere contrivance for abridging common language, to a system of symbolical writing, admirably fitted to assist the mind in the exercise of thought.

The happy idea, indeed, of expressing quantity, and the operations on quantity, by conventional symbols, instead of representing the first by real magnitudes, and enunciating the second in words, could not but make a great change on the nature of mathematical investigation. The language of mathematics, whatever may be its form, must always consist of two parts ; the one denoting quantities simply, and the other denoting the manner in which the quantities are combined, or the operations understood to be performed on them. Geometry expresses the first of these by real magnitudes, or by what may be called natural signs ; a line by a line, an angle by an angle, an area by an area, &c. ; and it describes the latter by words. Algebra, on the other hand, denotes both quantity, and the operations on quantity, by the same system of conventional symbols. Thus, in the expression $x^3 - ax^2 + b^3 = 0$, the letters a , b , x , denote quantities, but the terms x^3 , ax^2 , &c. denote certain operations performed on those quantities, as well as the quantities themselves ; x^3 is the quantity x raised to the cube ; and ax^2 the same quantity x raised to the square, and then multiplied into a , &c. ; the combination, by addition or subtraction, being also expressed by the signs $+$ and $-$.

Now, it is when applied to this latter purpose that the algebraic language possesses such exclusive excellence. The mere magnitudes themselves might be represented by figures, as in geometry, as well as in any way whatever ; but the operations they are to be subjected to, if described in words, must be set before the mind slowly, and in succession, so that the impression is weakened, and the clear apprehension rendered difficult. In the algebraic expression, on the other hand, so much meaning is concentrated into a narrow space, and the impression made by all the parts is so simultaneous, that nothing can be more favourable to the exertion of the reasoning powers, to the continuance of their action, and their security against error. Another advantage resulting from the use of the

same notation, consists in the reduction of all the different relations among quantities to the simplest of those relations, that of equality, and the expression of it by equations. This gives a great facility of generalization, and of comparing quantities with one another. A third arises from the substitution of the arithmetical operations of multiplication and division, for the geometrical method of the composition and resolution of ratios. Of the first of these, the idea is so clear, and the work so simple; of the second, the idea is comparatively so obscure, and the process so complex, that the substitution of the former for the latter could not but be accompanied with great advantage. This is, indeed, what constitutes the great difference in practice between the algebraic and the geometric method of treating quantity. When the quantities are of a complex nature, so as to go beyond what in algebra is called the third power, the geometrical expression is so circuitous and involved, that it renders the reasoning most laborious and intricate. The great facility of generalization in algebra, of deducing one thing from another, and of adapting the analysis to every kind of research, whether the quantities be constant or variable, finite or infinite, depends on this principle more than any other. Few of the early algebraists seem to have been aware of these advantages.

The use of the signs *plus* and *minus* has given rise to some dispute. These signs were at first used the one to denote addition, the other subtraction, and for a long time were applied to no other purpose. But as, in the multiplication of a quantity, consisting of parts connected by those signs, into another quantity similarly composed, it was always found, and could be universally demonstrated, that, in uniting the particular products of which the total was made up, those of which both the factors had the sign *minus* before them, must be added into one sum with those of which all the factors had the sign *plus*; while those of which one of the factors had the sign *plus*, and the other the sign *minus*, must be subtracted from the same,—this general rule came to be more simply expressed by saying, that in multiplication like signs gave *plus*, and that unlike signs gave *minus*.

Hence the signs *plus* and *minus* were considered, not as merely denoting the relation of one quantity to another placed before it, but, by a kind of *fiction*, they were considered as denoting qualities inherent in the quantities to the names of which they were prefixed. This fiction was found extremely useful, and it was evident that no error could arise from it. It was necessary to have a rule for determining the sign belonging to a product, from the signs of the factors composing that product, independently of every other consideration; and this was precisely the purpose for which the above fiction was introduced. So necessary is this rule in the generalizations of algebra, that we meet with it in Diophantus, notwithstanding the imperfection of the language he employed; for he states, that

$\Delta\epsilon\psi\iota\varsigma$ into $\Delta\iota\psi\iota\varsigma$ gives $\Upsilon\pi\alpha\sigma\zeta\iota\varsigma$, &c. The reduction, therefore, of the operations on quantity to an arithmetical form, necessarily involves this use of the signs *plus* or *minus*; that is, their application to denote something like absolute qualities in the objects they collect together. The attempts to free algebra from this use of the signs have of course failed, and must ever do so, if we would preserve to that science the extent and facility of its operations.

Even the most scrupulous purist in mathematical language must admit, that no real error is ever introduced by employing the signs in this most abstract sense. If the equation $x^3 + px^2 + qx + r = 0$, be said to have one positive and two negative roots, this is certainly as exceptionable an application of the term *negative*, as any that can be proposed; yet, in reality, it means nothing but this intelligible and simple truth, that $x^3 + px^2 + qx + r = (x-a)(x+b)(x+c)$; or that the former of these quantities is produced by the multiplication of the three binomial factors, $x-a$, $x+b$, $x+c$. We might say the same nearly as to imaginary roots; they show that the simple factors cannot be found, but that the quadratic factors may be found; and they also point out the means of discovering them.

The aptitude of these same signs to denote contrariety of position among geometric magnitudes, makes the foregoing application of them infinitely more extensive and more indispensable.

From the same source arises the great simplicity introduced into many of the theorems and rules of the mathematical sciences. Thus, the rule for finding the latitude of a place from the sun's meridian altitude, if we employ the signs *plus* and *minus* for indicating the position of the sun and of the place relatively to the equator, is enunciated in one simple proposition, which includes every case, without any thing either complex or ambiguous. But if this is not done,—if the signs *plus* and *minus* are not employed, there must be at least two rules, one when the sun and place are on the same side of the equator, and another when they are on different sides. In the more complicated calculations of spherical trigonometry, this holds still more remarkably. When one would accommodate such rules to those who are unacquainted with the use of the algebraic signs, they are perhaps not to be expressed in less than four, or even six different propositions; whereas, if the use of these signs is supposed, the whole is comprehended in a single sentence. In such cases, it is obvious that both the memory and understanding derive great advantage from the use of the signs, and profit by a simplification, which is the work entirely of the algebraic language, and cannot be imitated by any other.

That I might not interrupt the view of improvements so closely connected with one another, I have passed over one of the discoveries, which does the greatest honour to the seventeenth century, and which took place near the beginning of it.

As the accuracy of astronomical observation had been continually advancing, it was necessary that the correctness of trigonometrical calculation, and of course its difficulty, should advance in the same proportion. The signs and tangents of angles could not be expressed with sufficient correctness without decimal fractions, extending to five or six places below unity, and when to three such numbers a fourth proportional was to be found, the work of multiplication and division became extremely laborious. Accordingly, in the end of the sixteenth century, the time and labour consumed in such calculations had become excessive, and were felt as extremely burdensome by the mathematicians and astronomers all over Europe. Napier of Merchiston, whose mind seems to have been peculiarly turned to arithmetical researches, and who was also devoted to the study of astronomy, had early sought for the means of relieving himself and others from this difficulty. He had viewed the subject in a variety of lights, and a number of ingenious devices had occurred to him, by which the tediousness of arithmetical operations might, more or less completely, be avoided. In the course of these attempts, he did not fail to observe, that whenever the numbers to be multiplied or divided were terms of a geometrical progression, the product or the quotient must also be a term of that progression, and must occupy a place in it pointed out by the places of the given numbers, so that it might be found from mere inspection, if the progression were far enough continued. If, for instance, the third term of the progression were to be multiplied by the seventh, the product must be the tenth, and if the twelfth were to be divided by the fourth, the quotient must be the eighth; so that the multiplication and division of such terms was reduced to the addition and subtraction of the numbers which indicated their places in the progression.

This observation, or one very similar to it, was made by Archimedes, and was employed by that great geometer to convey an idea of a number too vast to be correctly expressed by the arithmetical notation of the Greeks. Thus far, however, there was no difficulty, and the discovery might certainly have been made by men much inferior either to Napier or Archimedes. What remained to be done, what Archimedes did not attempt, and what Napier completely performed, involved two great difficulties. It is plain, that the resource of the geometrical progression was sufficient, when the given numbers were terms of that progression; but if they were not, it did not seem that any advantage could be derived from it. Napier, however, perceived, and it was by no means obvious, that all numbers whatsoever might be inserted in the progression, and have their places assigned in it. After conceiving the possibility of this, the next difficulty was, to discover the principle, and to execute the arithmetical process, by which these places were to be ascertained. It is in these two points that the peculiar merit of his invention consists; and at a period

when the nature of series, and when every other resource of which he could avail himself were so little known, his success argues a depth and originality of thought which, I am persuaded, have rarely been surpassed.

The way in which he satisfied himself that all numbers might be intercalated between the terms of the given progression, and by which he found the places they must occupy, was founded on a most ingenious supposition,—that of two points describing two different lines, the one with a constant velocity, and the other with a velocity always increasing in the ratio of the space the point had already gone over : the first of these would generate magnitudes in arithmetical, and the second magnitudes in geometrical progression. It is plain, that all numbers whatsoever would find their places among the magnitudes so generated ; and, indeed, this view of the subject is as simple and profound as any which, after two hundred years, has yet presented itself to mathematicians. The mode of deducing the results has been simplified ; but it can hardly be said that the principle has been more clearly developed.

I need not observe, that the numbers which indicate the places of the terms of the geometrical progression are called by Napier the *logarithms* of those terms.

Various systems of logarithms, it is evident, may be constructed according to the geometrical progression assumed ; and of these, that which was first contrived by Napier, though the simplest, and the foundation of the rest, was not so convenient for the purposes of calculation, as one which soon afterwards occurred, both to himself and his friend Briggs, by whom the actual calculation was performed. The new system of logarithms was an improvement, practically considered ; but in as far as it was connected with the principle of the invention, it is only of secondary consideration. The original tables had been also somewhat embarrassed by too close a connection between them and trigonometry. The new tables were free from this inconvenience.

It is probable, however, that the greatest inventor in science was never able to do more than to accelerate the progress of discovery, and to anticipate what time, “the author of authors,” would have gradually brought to light. Though logarithms had not been invented by Napier, they would have been discovered in the progress of the algebraic analysis, when the arithmetic of powers and exponents, both integral and fractional, came to be fully understood. The idea of considering all numbers, as powers of one given number, would then have readily occurred, and the doctrine of series would have greatly facilitated the calculations which it was necessary to undertake. Napier had none of these advantages, and they were all supplied by the resources of his own mind. Indeed, as there never was any invention for which the state of knowledge had less prepared the way, there never was any where more merit fell to the share of the inventor.

His good fortune, also, not less than his great sagacity, may be remarked. Had the invention of logarithms been delayed to the end of the seventeenth century, it would have come about without effort, and would not have conferred on the author the high celebrity which Napier so justly derives from it. In another respect he has also been fortunate. Many inventions have been eclipsed or obscured by new discoveries; or they have been so altered by subsequent improvements, that their original form can hardly be recognised, and, in some instances, has been entirely forgotten. This has almost always happened to the discoveries made at an early period in the progress of science, and before their principles were fully unfolded. It has been quite otherwise with the invention of logarithms, which came out of the hands of the author so perfect, that it has never received but one material improvement, that which it derived, as has just been said, from the ingenuity of his friend in conjunction with his own. Subsequent improvements in science, instead of offering any thing that could supplant this invention, have only enlarged the circle to which its utility extended. Logarithms have been applied to numberless purposes, which were not thought of at the time of their first construction. Even the sagacity of their author did not see the immense fertility of the principle he had discovered; he calculated his tables merely to facilitate arithmetical, and chiefly trigonometrical computation, and little imagined that he was at the same time constructing a scale whereon to measure the density of the strata of the atmosphere, and the heights of mountains; that he was actually computing the areas and the lengths of innumerable curves, and was preparing for a calculus which was yet to be discovered, many of the most refined and most valuable of its resources. Of Napier, therefore, if of any man, it may safely be pronounced, that his name will never be eclipsed by any one more conspicuous, or his invention superseded by any thing more valuable.

As a geometrician, Napier has left behind him a noble monument in the two trigonometrical theorems, which are known by his name, and which appear first to have been communicated in writing to Cavalleri, who has mentioned them with great eulogy.¹ They are theorems not a little difficult, and of much use, as being particularly adapted to logarithmic calculation. They were published in the *Canon Mirificus Logarithmorum*, at Edinburgh, in 1614.²

¹ Wallis, Opera Math. Tom. II. p. 875.

² A reprint of the *Canon Mirificus*, from the original edition, is given in the 6th Volume of the great *Thesaurus*, in which Baron Maseres, with his usual zeal and intelligence, has collected and illustrated every thing of importance that has been written on the subject of logarithms. See *Scriptores Logarithmici*, 4to. Vol. VI. p. 475.

SECTION II.

EXPERIMENTAL INVESTIGATION.

In this section I shall begin with a short view of the state of Physical Knowledge before the introduction of the Inductive Method; I shall next endeavour to explain that method by an analysis of the *Novum Organum*; and shall then inquire how far the principles established in that work have actually contributed to the advancement of Natural Philosophy.

1. ANCIENT PHYSICS.

Though the phenomena of the material world could not but early excite the curiosity of a being who, like man, receives his strongest impressions from without, yet an accurate knowledge of those phenomena, and their laws, was not to be speedily acquired. The mere extent and variety of the objects were, indeed, such obstacles to that acquisition, as could not be surmounted but in the course of many ages. Man could not at first perceive from what point he must begin his inquiries, in what direction he must carry them on, or by what rules he must be guided. He was like a traveller going forth to explore a vast and unknown wilderness, in which a multitude of great and interesting objects presented themselves on every side, while there was no path for him to follow, no rule to direct his survey, and where the art of observing, and the instruments of observation, must equally be the work of his own invention. In these circumstances, the selection of the objects to be studied was the effect of instinct rather than of reason, or of the passions and emotions, more than of the understanding. When things new and unlike those which occurred in the course of every day's experience presented themselves, they excited wonder or surprise, and created an anxiety to discover some principle which might connect them with the appearances commonly observed. About these last, men felt no desire to be farther informed; but when the common order of things was violated, and something new or singular was produced, they began to examine into the fact, and attempted to inquire into the cause. Nobody sought to know why a stone fell to the ground, why smoke ascended, or why the stars revolved round the earth. But if a fiery meteor shot across the heavens,—if the flames of a volcano burst forth,—or if an earthquake shook the foundations of the

world, terror and curiosity were both awakened ; and when the former emotion had subsided, the latter was sure to become active. Thus, to trace a resemblance between the events with which the observer was most familiar, and those to which he was less accustomed, and which had excited his wonder, was the first object of inquiry, and produced the first advances towards generalization and philosophy. ¹

This principle, which it were easy to trace, from tribes the most rude and barbarous, to nations the most highly refined, was what yielded the first attempts toward classification and arrangement, and enabled man, out of individuals, subject to perpetual change, to form certain fixed and permanent objects of knowledge,—the species, genera, orders, and classes, into which he has distributed these individuals. By this effort of mental abstraction, he has created to himself a new and intellectual world, free from those changes and vicissitudes to which all material things are destined. This, too, is a work not peculiar to the philosopher, but, in a certain degree, is performed by every man who compares one thing with another, and who employs the terms of ordinary language.

Another great branch of knowledge is occupied, not about the mere arrangement and classification of objects, but about events or changes, the laws which those changes observe, and the causes by which they are produced. In a science, which treated of events and of change, the nature and properties of motion came of course to be studied, and the ancient philosophers naturally enough began their inquiries with the definition of motion, or the determination of that in which it consists. Aristotle's definition is highly characteristic of the vagueness and obscurity of his physical speculations. He calls motion "the act of a being in power, as far as in power,"—words to which it is impossible that any distinct idea can ever have been annexed.

The truth is, however, that the best definition of motion can be of very little service in physics. Epicurus defined it to be the "change of place," which is, no doubt, the simplest and best definition that can be given ; but it must, at the same time, be confessed, that neither he nor the moderns who have retained his definition, have derived the least advantage from it in their subsequent researches. The properties, or, as they are called, the laws of motion, cannot be derived from mere definition ; they must be sought for in ex-

¹ La meraviglia
Dell'ignoranza é la figlia,
E del sapere
La madre.

perience and observation, and are not to be found without a diligent comparison, and scrupulous examination of facts. Of such an examination, neither Aristotle, nor any other of the ancients, ever conceived the necessity, and hence those laws remained quite unknown throughout all antiquity.

When the laws of motion were unknown, the other parts of natural philosophy could make no great advances. Instead of conceiving that there resides in *body* a natural and universal tendency to persevere in the same state, whether of rest, or of motion, they believed that terrestrial bodies tended *naturally* either to fall to the ground, or to ascend from it, till they attained their own place; but that, if they were impelled by an oblique force, then their motion became *unnatural* or *violent*, and tended continually to decay. With the heavenly bodies, again, the natural motion was circular and uniform, eternal in its course, but perpetually varying in its direction. Thus, by the distinction between natural and violent motion among the bodies of the earth, and the distinction between what we may call the laws of motion in terrestrial and celestial bodies, the ancients threw into all their reasonings upon this fundamental subject a confusion and perplexity, from which their philosophy never was delivered.

There was, however, one part of physical knowledge in which their endeavours were attended with much better success, and in which they made important discoveries. This was in the branch of Mechanics, which treats of the action of forces *in equilibrio*, and producing not motion but rest;—a subject which may be understood, though the laws of motion are unknown.

The first writer on this subject is Archimedes. He treated of the lever, and of the centre of gravity, and has shown that there will be an equilibrium between two heavy bodies connected by an inflexible rod or lever, when the point in which the lever is supported is so placed between the bodies, that their distances from it are inversely as their weights. Great ingenuity is displayed in this demonstration; and it is remarkable, that the author borrows no principle from experiment, but establishes his conclusion entirely by reasoning *a priori*. He assumes, indeed, that equal bodies, at the ends of the equal arms of a lever, will balance one another; and also, that a cylinder, or parallelopiped of homogeneous matter, will be balanced about its centre of magnitude. These, however, are not inferences from experience; they are, properly speaking, conclusions deduced from the principle of the *sufficient reason*.

The same great geometer gave a beginning to the science of Hydrostatics, and discovered the law which determines the loss of weight sustained by a body on being immersed in

water, or in any other fluid. His demonstration rests on a principle, which he lays down as a postulatum, that, in water, the parts which are less pressed are always ready to yield in any direction to those that are more pressed, and from this, by the application of mathematical reasoning, the whole theory of floating bodies is derived. The above is the same principle on which the modern writers on hydrostatics proceed; they give it not as a postulatum, but as constituting the definition of a fluid.

Archimedes, therefore, is the person who first made the application of mathematics to natural philosophy. No individual, perhaps, ever laid the foundation of more great discoveries than that geometer, of whom Wallis has said with so much truth, “*Vir stupendæ sagacitatis, qui prima fundamenta posuit inventionum ferè omnium in quibus promovendis ætas nostra gloriatur.*”

The mechanical inquiries, begun by the geometer of Syracuse, were extended by Ctesibius and Hero; by Anthemius of Tralles; and, lastly, by Pappus Alexandrinus. Ctesibius and Hero were the first who analyzed mechanical engines, reducing them all to combinations of five simple mechanical contrivances, to which they gave the name of *Δυναμικα*, or Powers, the same which they retain at the present moment.

Even in mechanics, however, the success of these investigations was limited; and failed in those cases where the resolution of forces is necessary, that principle being then entirely unknown. Hence the force necessary to sustain a body on an inclined plane, is incorrectly determined by Pappus, and serves to mark a point to which the mechanical theories of antiquity did not extend.

In another department of physical knowledge, Astronomy, the endeavours of the ancients were also accompanied with success. I do not here speak of their astronomical theories, which were, indeed, very defective, but of their discovery of the apparent motions of the heavenly bodies, from the observations begun by Hipparchus, and continued by Ptolemy. In this their success was great; and while the earth was supposed to be at rest, and while the instruments of observation had but a very limited degree of accuracy, a nearer approach to the truth was probably not within the power of human ingenuity. Mathematical reasoning was very skilfully applied, and no men whatever, in the same circumstances, are likely to have performed more than the ancient astronomers. They succeeded, because they were observers, and examined carefully the motions which they treated of. The philosophers, again, who studied the motion of terrestrial bodies, either did not observe at all, or observed so slightly, that they could obtain no accurate knowledge, and in general they knew just enough of the facts to be misled by them.

The opposite ways which the ancients thus took to study the Heavens and the Earth, observing the one, and dreaming, as one may say, over the other, though a striking inconsistency, is not difficult to be explained.

No information at all could be obtained in astronomy, without regular and assiduous observation, and without instruments capable of measuring angles, and of measuring time, either directly or indirectly. The steadiness and regularity of the celestial-motions seemed to invite the most scrupulous attention. On the other hand, as terrestrial objects were always at hand, and spontaneously falling under men's view, it seemed unnecessary to take much trouble to become acquainted with them, and as for applying measures, their irregularity appeared to render every idea of such proceeding nugatory. The Aristotelian philosophy particularly favoured this prejudice, by representing the earth, and all things on its surface, as full of irregularity and confusion, while the principles of heat and cold, dryness and moisture, were in a state of perpetual warfare. The unfortunate division of motion into natural and violent, and the distinction, still more unfortunate, between the properties of motion and of body, in the heavens and on the earth, prevented all intercourse between the astronomer and the naturalist, and all transference of the maxims of the one to the speculations of the other.

Though, on account of this inattention to experiment, nothing like the true system of natural philosophy was known to the ancients, there are, nevertheless, to be found in their writings many brilliant conceptions, several fortunate conjectures, and gleams of the light which was afterwards to be so generally diffused.

Anaxagoras and Empedocles, for example, taught that the moon shines by light borrowed from the sun, and were led to that opinion, not only from the phases of the moon, but from its light being weak, and unaccompanied by heat. That it was a habitable body, like the earth, appears to be a doctrine as old as Orpheus; some lines, ascribed to that poet, representing the moon as an earth, with mountains and cities on its surface.

Democritus supposed the spots on the face of the moon to arise from the inequalities of the surface, and from the shadows of the more elevated parts projected on the plains. Every one knows how conformable this is to the discoveries made by the telescope.

Plutarch considers the velocity of the moon's motion as the cause which prevents that body from falling to the earth, just as the motion of a stone in a sling prevents it from falling to the ground. The comparison is, in a certain degree, just, and clearly implies the notion of centrifugal force; and gravity may also be considered as pointed at for the cause which gives the moon a tendency to the earth. Here, therefore, a foundation was

laid for the true philosophy of the celestial motions ; but it was laid without effect. It was merely the conjecture of an ingenious mind, wandering through the regions of possibility, guided by no evidence, and having no principle which could give stability to its opinions. Democritus, and the authors of that physical system which Lucretius has so beautifully illustrated, were still more fortunate in some of their conjectures. They taught that the Milky Way is the light of a great number of small stars, very close to one another ; a magnificent conception, which the latest improvements of the telescope have fully verified. Yet, as if to convince us that they derived this knowledge from no pure or certain source, the same philosophers maintained, that the sun and the moon are bodies no larger than they appear to us to be.

Very just notions concerning comets were entertained by some of the ancients. The Chaldeans considered those bodies as belonging to the same order with the planets ; and this was also the opinion of Anaxagoras, Pythagoras, and Democritus. The remark of Seneca on this subject is truly philosophical, and contains a prediction which has been fully accomplished : “ Why do we wonder that comets, which are so rare a spectacle in the world, observe laws which to us are yet unknown, and that the beginning and end of motions, so seldom observed, are not yet fully understood ? ” — *Veniet tempus, quo ista quæ nunc latent, in lucem dies extrahat, et longioris ævi diligentia : ad inquisitionem tantorum ætas una non sufficit. Veniet tempus, quo posteri nostri tam aperta nos nescisse mirentur.*¹

It was, however, often the fate of such truths to give way to error. The comets, which these ancient philosophers had ranked so justly with the stars, were degraded by Aristotle into meteors floating in the earth's atmosphere ; and this was the opinion concerning them which ultimately prevailed.

But, notwithstanding the above, and a few other splendid conceptions which shine through the obscurity of the ancient physics, the system, taken on the whole, was full of error and inconsistency. Truth and falsehood met almost on terms of equality ; the former separated from its root, experience, found no preference above the latter ; to the latter, in fact, it was generally forced to give way, and the dominion of error was finally established.

One ought to listen, therefore, with caution to the encomiums sometimes bestowed on the philosophy of those early ages. If these encomiums respected only the talents, the

¹ Nat. Quest. Lib. vii. c. 25.

genius, the taste of the great masters of antiquity, we would subscribe to them without any apprehension of going beyond the truth. But if they extend to the methods of philosophizing, and the discoveries actually made, we must be excused for entering our dissent, and exchanging the language of panegyric for that of apology. The infancy of science could not be the time when its attainments were the highest ; and, before we suffer ourselves to be guided by the veneration of antiquity, we ought to consider in what real antiquity consists. With regard to the progress of knowledge and improvement, “we are more ancient than those who went before us.”¹ The human race has now more experience than in the generations that are past, and of course may be expected to have made higher attainments in science and philosophy. Compared with natural philosophy, as it now exists, the ancient physics are rude and imperfect. The speculations contained in them are vague and unsatisfactory, and of little value, but as they elucidate the history of the errors and illusions to which the human mind is subject. Science was not merely stationary, but often retrograde ; the earliest opinions were frequently the best ; and the reasonings of Democritus and Anaxagoras were in many instances more solid than those of Plato and Aristotle. Extreme credulity disgraced the speculations of men who, however ingenious, were little acquainted with the laws of nature, and unprovided with the great criterion by which the evidence of testimony can alone be examined. Though observations were sometimes made, experiments were never instituted ; and philosophers, who were little attentive to the facts which spontaneously offered, did not seek to increase their number by artificial combinations. Experience, in those ages, was a light which darted a few tremulous and uncertain rays on some small portions of the field of science, but men had not acquired the power over that light which now enables them to concentrate its beams, and to fix them steadily on whatever object they wish to examine. This power is what distinguishes the modern physics, and is the cause why later philosophers, without being more ingenious than their predecessors, have been infinitely more successful in the study of nature.

2. NOVUM ORGANUM.

The defects which have been ascribed to the ancient physics were not likely to be corrected in the course of the middle ages. It is true, that, during those ages, a science of pure

¹ Bacon.

experiment had made its appearance in the world, and might have been expected to remedy the greatest of these defects, by turning the attention of philosophers to experience and observation. This effect, however, was far from being immediately produced; and none who professed to be in search of truth ever wandered over the regions of fancy, in paths more devious and eccentric, than the first experimenters in chemistry. They had become acquainted with a series of facts so unlike to any thing already known, that the ordinary principles of belief were shaken or subverted, and the mind laid open to a degree of credulity far beyond any with which the philosophers of antiquity could be reproached. An unlooked-for extension of human power had taken place; its limits were yet unknown; and the boundary between the possible and the impossible was no longer to be distinguished. The adventurers in an unexplored country, given up to the guidance of imagination, pursued objects which the kindness, no less than the wisdom of nature, have rendered unattainable by man; and in their speculations peopled the air, the earth, and all the elements, with spirits and genii, the invisible agents destined to connect together all the facts which they knew, and all those which they hoped to discover. Chemistry, in this state, might be said to have an elective attraction for all that was most absurd and extravagant in the other parts of knowledge; alchemy was its immediate offspring, and it allied itself in succession with the dreams of the Cabbalists, the Rosicrucians, and the Theosophers. Thus a science, founded in experiment, and destined one day to afford such noble examples of its use, exhibited for several ages little else than a series of illusory pursuits, or visionary speculations, while now and then a fact was accidentally discovered.

Under the influence of these circumstances arose Paracelsus, Van Helmont, Fludde, Cardan, and several others, conspicuous no less for the weakness than the force of their understandings: men who united extreme credulity, the most extravagant pretensions, and the most excessive vanity, with considerable powers of invention, a complete contempt for authority, and a desire to consult experience; but destitute of the judgment, patience, and comprehensive views, without which the responses of that oracle are never to be understood. Though they appealed to experience, and disclaimed subjection to the old legislators of science, they were in too great haste to become legislators themselves, and to deduce an explanation of the whole phenomena of nature from a few facts, observed without accuracy, arranged without skill, and never compared or confronted with one another. Fortunately, however, from the turn which their inquiries had taken, the ill done by them has passed away, and the good has become permanent. The reveries of Paracelsus have disappeared, but his application of chemistry to pharmacy has conferred a lasting benefit on the

world. The *Archæus* of Van Helmont, and the army of spiritual agents with which the discovery of elastic fluids had filled the imagination of that celebrated empiric, are laughed at, or forgotten; but the fluids which he had the sagacity to distinguish, form, at the present moment, the connecting principles of the new chemistry.

Earlier than any of the authors just named, but in a great measure under the influence of the same delusions, Roger Bacon appears to have been more fully aware than any of them of the use of experiment, and of mathematical reasoning, in physical and mechanical inquiries. But, in the thirteenth century, an appeal from the authority of the schools, even to nature herself, could not be made with impunity. Bacon, accordingly, incurred the displeasure both of the University and of the Church, and this forms one of his claims to the respect of posterity, as it is but fair to consider persecution inflicted by the ignorant and bigoted as equivalent to praise bestowed by the liberal and enlightened.

Much more recently, Gilbert, in his treatise on the Magnet, had given an example of an experimental inquiry, carried on with more correctness, and more enlarged views, than had been done by any of his predecessors. Nevertheless, in the end of the sixteenth century, it might still be affirmed, that the situation of the great avenue to knowledge was fully understood by none, and that its existence, to the bulk of philosophers, was utterly unknown.

It was about this time that Francis Bacon (Lord Verulam) began to turn his powerful and creative mind to contemplate the state of human knowledge, to mark its imperfections, and to plan its improvement. One of the considerations which appears to have impressed his mind most forcibly, was the vagueness and uncertainty of all the physical speculations then existing, and the entire want of connection between the sciences and the arts.

Though these two things are in their nature so closely united, that the same truth which is a principle in science, becomes a rule in art, yet there was at that time hardly any practical improvement which had arisen from a theoretical discovery. The natural alliance between the knowledge and the power of man seemed entirely interrupted; nothing was to be seen of the mutual support which they ought to afford to one another; the improvement of art was left to the slow and precarious operation of chance, and that of science to the collision of opposite opinions.

“But whence,” said Bacon, “can arise such vagueness and sterility in all the physical systems which have hitherto existed in the world? It is not certainly from any thing in nature itself; for the steadiness and regularity of the laws by which it is governed clearly

mark them out as objects of certain and precise knowledge. Neither can it arise from any want of ability in those who have pursued such inquiries, many of whom have been men of the highest talent and genius of the ages in which they lived ; and it can, therefore, arise from nothing else but the perverseness and insufficiency of the methods that have been pursued. Men have sought to make a world from their own conceptions, and to draw from their own minds all the materials which they employed ; but if, instead of doing so, they had consulted experience and observation, they would have had facts, and not opinions, to reason about, and might have ultimately arrived at the knowledge of the laws which govern the material world."

"As things are at present conducted," he adds, "a sudden transition is made from sensible objects and particular facts to general propositions, which are accounted principles, and round which, as round so many fixed poles, disputation and argument continually revolve. From the propositions thus hastily assumed, all things are derived, by a process compendious and precipitate, ill suited to discovery, but wonderfully accommodated to debate. The way that promises success is the reverse of this. It requires that we should generalize slowly, going from particular things to those that are but one step more general ; from those to others of still greater extent, and so on to such as are universal. By such means, we may hope to arrive at principles, not vague and obscure, but luminous and well-defined, such as nature herself will not refuse to acknowledge."

Before laying down the rules to be observed in this inductive process, Bacon proceeds to enumerate the causes of error,—the *Idols*, as he terms them, in his figurative language, or false divinities to which the mind had so long been accustomed to bow. He considered this enumeration as the more necessary, that the same idols were likely to return, even after the reformation of science, and to avail themselves of the real discoveries that might have been made, for giving a colour to their deceptions.

These idols he divides into four classes, to which he gives names, fantastical, no doubt, but, at the same time, abundantly significant.

Idola Tribus,	Idols of the Tribe,
—— Specus,	—— of the Den,
—— Fori,	—— of the Forum,
—— Theatri,	—— of the Theatre.

1. The *idols of the tribe*, or of the race, are the causes of error founded on human nature in general, or on principles common to all mankind. "The mind," he observes, "is not like a plain mirror, which reflects the images of things exactly as they are ; it is like

a mirror of an uneven surface, which combines its own figure with the figures of the objects it represents.”¹

Among the idols of this class, we may reckon the propensity which there is in all men to find in nature a greater degree of order, simplicity, and regularity, than is actually indicated by observation. Thus, as soon as men perceived the orbits of the planets to return into themselves, they immediately supposed them to be perfect circles, and the motion in those circles to be uniform; and to these hypotheses, so rashly and gratuitously assumed, the astronomers and mathematicians of all antiquity laboured incessantly to reconcile their observations.

The propensity which Bacon has here characterized so well, is the same that has been, since his time, known by the name of the *spirit of system*. The prediction, that the sources of error would return, and were likely to infest science in its most flourishing condition, has been fully verified with respect to this illusion, and in the case of sciences which had no existence at the time when Bacon wrote. When it was ascertained, by observation, that a considerable part of the earth's surface consists of minerals, disposed in horizontal strata, it was immediately concluded, that the whole exterior crust of the earth is composed, or has been composed, of such strata, continued all round without interruption; and on this, as on a certain and general fact, entire theories of the earth have been constructed.

There is no greater enemy which science has to struggle with than this propensity of the mind; and it is a struggle from which science is never likely to be entirely relieved; because, unfortunately, the illusion is founded on the same principle from which our love of knowledge takes its rise.

2. The *idols of the den* are those that spring from the peculiar character of the individual. Besides the causes of error which are common to all mankind, each individual, according to Bacon, has his own dark cavern or den, into which the light is imperfectly admitted, and in the obscurity of which a tutelary idol lurks, at whose shrine the truth is often sacrificed.

One great and radical distinction in the capacities of men is derived from this, that some minds are best adapted to mark the differences, others to catch the resemblances, of things. Steady and profound understandings are disposed to attend carefully, to proceed slowly, and to examine the most minute differences; while those that are sublime

¹ *Novum Organum*, Lib. i. Aph. 41.

and active are ready to lay hold of the slightest resemblances. Each of these easily runs into excess; the one by catching continually at distinctions, the other at affinities.

The studies, also, to which a man is addicted, have a great effect in influencing his opinions. Bacon complains, that the chemists of his time, from a few experiments with the furnace and the crucible, thought that they were furnished with principles sufficient to explain the structure of the universe; and he censures Aristotle for having depraved his physics so much with his dialectics, as to render the former entirely a science of words and controversy. In like manner, he blames a philosopher of his own age, Gilbert, who had studied magnetism to good purpose, for having proceeded to form out of it a general system of philosophy. Such things have occurred in every period of science. Thus electricity has been applied to explain the motion of the heavenly bodies; and, of late, galvanism and electricity together have been held out as explaining, not only the affinities of chemistry, but the phenomena of gravitation, and the laws of vegetable and animal life. It were a good caution for a man who studies nature, to distrust those things with which he is particularly conversant, and which he is accustomed to contemplate with pleasure.

3. The *idols of the forum* are those that arise out of the commerce or intercourse of society, and especially from language, or the means by which men communicate their thoughts to one another.

Men believe that their thoughts govern their words; but it also happens, by a certain kind of reaction, that their words frequently govern their thoughts. This is the more pernicious, that words, being generally the work of the multitude, divide things according to the lines most conspicuous to vulgar apprehensions. Hence, when words are examined, few instances are found in which, if at all abstract, they convey ideas tolerably precise and well defined. For such imperfections there seems to be no remedy, but by having recourse to particular instances, and diligently comparing the meanings of words with the external archetypes from which they are derived.

4. The *idols of the theatre* are the last, and are the deceptions which have taken their rise from the systems or dogmas of the different schools of philosophy. In the opinion of Bacon, as many of these systems as had been invented, so many representations of imaginary worlds had been brought upon the stage. Hence the name of *idola theatri*. They do not enter the mind imperceptibly like the other three; a man must labour to acquire them, and they are often the result of great learning and study.

“Philosophy,” said he, “as hitherto pursued, has taken much from a few things, or a little from a great many; and, in both cases, has too narrow a basis to be of much dura-

tion or utility." The Aristotelian philosophy is of the latter kind ; it has taken its principles from common experience, but without due attention to the evidence or the precise nature of the facts ; the philosopher is left to work out the rest from his own invention. Of this kind, called by Bacon the *sophistical*, were almost all the physical systems of antiquity.

When philosophy takes all its principles from a few facts, he calls it *empirical*,—such as was that of Gilbert, and of the chemists.

It should be observed, that Bacon does not charge the physics of antiquity with being absolutely regardless of experiment. No system, indeed, however fantastical, has ever existed, to which that reproach could be applied in its full extent ; because, without some regard to fact, no theory can ever become in the least degree plausible. The fault lies not, therefore, in the absolute rejection of experience, but in the unskilful use of it ; in taking up principles lightly from an inaccurate and careless observation of many things ; or, if the observations have been more accurate, from those made on a few facts, unwarrantably generalized.

Bacon proceeds to point out the circumstances, in the history of the world, which had hitherto favoured these perverse modes of philosophizing. He observes, that the periods during which science had been cultivated were not many, nor of long duration. They might be reduced to three ; the first with the Greeks ; the second with the Romans ; and the third with the western nations, after the revival of letters. In none of all these periods had much attention been paid to natural philosophy, the great parent of the sciences.

With the Greeks, the time was very short during which physical science flourished in any degree. The seven Sages, with the exception of Thales, applied themselves entirely to morals and politics ; and in later times, after Socrates had brought down philosophy from the heavens to the earth, the study of nature was generally abandoned. In the Roman republic, the knowledge most cultivated, as might be expected among a martial and ambitious people, was such as had a direct reference to war and politics. During the empire, the introduction and establishment of the Christian religion drew the attention of men to theological studies, and the important interests which were then at stake left but a small share of talent and ability to be occupied in inferior pursuits. The corruptions which followed, and the vast hierarchy which assumed the command both of the sword and the sceptre, while it occupied and enslaved the minds of men, looked with suspicion on sciences which could not easily be subjected to its control.

At the time, therefore, when Bacon wrote, it might truly be said, that a small portion.

even of the learned ages, and of the abilities of learned men, had been dedicated to the study of Natural Philosophy. This served, in his opinion, to account for the imperfect state in which he found human knowledge in general ; for he thought it certain, that no part of knowledge could attain much excellence without having its foundation laid in physical science.

He goes on to observe, that the end and object of knowledge had been very generally mistaken ; that many, instead of seeking through it to improve the condition of human life, by new inventions and new resources, had aimed only at popular applause, and had satisfied themselves with the knowledge of words more than of things : while others, who were exceptions to this rule, had gone still farther wrong, by directing their pursuits to objects imaginary and unattainable. The alchemists, for example, alternately the dupes of their own credulity and of their own imposture, had amazed and tormented the world with hopes which were never to be realized. Others, if possible more visionary, had promised to prolong life, to extinguish disease and infirmity, and to give man a command over the world of spirits, by means of mystic incantations. "All this," says he, "is the mere boasting of ignorance ; for, when the knowledge of nature shall be rightly pursued, it will lead to discoveries that will as far excel the pretended powers of magic, as the real exploits of Cæsar and Alexander exceed the fabulous adventures of Arthur of Britain, or Amadis of Gaul."¹

Again, the reverence for antiquity, and the authority of great names, have contributed much to retard the progress of science. Indeed, the notion of antiquity which men have taken up seems to be erroneous and inconsistent. It is the duration of the world, or of the human race, as reckoned from the extremity that is past, and not from the point of time which is present, that constitutes the true antiquity to which the advancement of science may be conceived to bear some proportion ; and just as we expect more wisdom and experience in an old than in a young man, we may expect more knowledge of nature from the present than from any of the ages that are past.

"It is not to be esteemed a small matter in this estimate, that, by the voyages and travels of these later times, so much more of nature has been discovered than was known at any former period. It would, indeed, be disgraceful to mankind, if, after such tracts of the material world have been laid open, which were unknown in former times,—so many seas traversed,—so many countries explored,—so many stars discovered,—that philosophy, or the intelligible world, should be circumscribed by the same boundaries as before."

¹ Nov. Org. Lib. i. Aph. 87.

Another cause has greatly obstructed the progress of philosophy, viz. that men inquire only into the causes of rare, extraordinary, and great phenomena, without troubling themselves about the explanation of such as are common, and make a part of the general course of nature.¹ It is, however, certain, that no judgment can be formed concerning the extraordinary and singular phenomena of nature, without² comparing them with those that are ordinary and frequent.

The laws which are every day in action, are those which it is most important for us to understand; and this is well illustrated by what has happened in the scientific world since the time when Bacon wrote. The simple falling of a stone to the ground has been found to involve principles which are the basis of all we know in mechanical philosophy. Without accurate experiments on the descent of bodies at the surface of the earth, the objections against the earth's motion could not have been answered, the inertia of body would have remained unknown, and the nature of the force which retains the planets in their orbits could never have been investigated. Nothing, therefore, can be more out of its place than the fastidiousness of those philosophers, who suppose things to be unworthy of study, because, with respect to ordinary life, they are trivial and unimportant. It is an error of the same sort which leads men to consider experiment, and the actual application of the hands, as unworthy of them, and unbecoming of the dignity of science. "There are some," says Bacon, "who, delighting in mere contemplation, are offended with our frequent reference to experiments and operations to be performed by the hand, things which appear to them mean and mechanical; but these men do in fact oppose the attainment of the object they profess to pursue, since the exercise of contemplation, and the construction and invention of experiments, are supported on the same principles, and perfected by the same means."²

After these preliminary discussions, the great restorer of philosophy proceeds, in the second book of the *Novum Organum*, to describe and exemplify the nature of the induction, which he deems essential to the right interpretation of nature.

The first object must be to prepare a history of the phenomena to be explained, in all their modifications and varieties. This history is to comprehend not only all such facts as spontaneously offer themselves, but all the experiments instituted for the sake of discovery, or for any of the purposes of the useful arts. It ought to be composed with great care; the facts accurately related, and distinctly arranged; their authenticity diligently examin-

¹ *Ibid.* Aph. 119.

² *Impetus Phil.* p. 681. Note C.

ed ; those that rest on doubtful evidence, though not rejected, being noted as uncertain, with the grounds of the judgment so formed. This last is very necessary ; for facts often appear incredible, only because we are ill informed, and cease to appear marvellous, when our knowledge is farther extended.

All such facts, however, as appear contrary to the ordinary course of our experience, though thus noted down and preserved, must have no weight allowed them in the first steps of investigation, and are to be used only when the general principle, as it emerges from the inductive process, serves to increase their probability.

This record of facts is what Bacon calls natural history, and it is material to take notice of the comprehensive sense in which that term is understood through all his writings. According to the arrangement of the sciences, which he has explained in his treatise on the advancement of knowledge, all learning is classed relatively to the three intellectual faculties of Memory, Reason, and Imagination. Under the first of these divisions is contained all that is merely Narration or History, of whatever kind it may be. Under the second are contained the different sciences, whether they respect the Intellectual or the Material world. Under the third are comprehended Poetry and the Fine Arts. It is with the first of these classes only that we are at present concerned. The two first divisions of it are Sacred and Civil History, the meaning of which is sufficiently understood. The third division is Natural History, which comprehends the description of the facts relative to inanimate matter, and to all animals, except man. Natural history is again subdivided into three parts : 1. The history of the phenomena of nature, which are uniform ; 2. Of the facts which are anomalous or extraordinary ; 3. Of the processes in the different arts.

We are not to wonder at finding the processes of the arts thus enrolled among the materials of natural history. The powers which act in the processes of nature and in those of art are precisely the same, and are only directed, in the latter case, by the intention of man, toward particular objects. In art, as Bacon elsewhere observes, man does nothing more than bring things nearer to one another, or carry them farther off ; the rest is performed by nature, and, on most occasions, by means of which we are quite ignorant.

Thus, when a man fires a pistol, he does nothing but make a piece of flint approach a plate of hardened steel, with a certain velocity. It is nature that does the rest ;—that makes the small red hot and fluid globules of steel, which the flint had struck off, communicate their fire to the gunpowder, and, by a process but little understood, set loose the elastic fluid contained in it ; so that an explosion is produced, and the ball propelled with

astonishing velocity. It is obvious that, in this instance, art only gives certain powers of nature a particular direction.

To the rules which have been given from Bacon, for the composition of natural history, I may be permitted to add this other,—that theoretical language should, as much as possible, be avoided. Appearances ought to be described in terms which involve no opinion with respect to their causes. These last are the objects of separate examination, and will be best understood if the facts are given fairly, without any dependence on what should yet be considered as unknown. This rule is very essential where the facts are in a certain degree complicated; for it is then much easier to describe with a reference to theory than without it. It is only from a skilful physician that you can expect a description of a disease which is not full of opinions concerning its cause. A similar observation might be made with respect to agriculture; and with respect to no science more than geology.

The natural history of any phenomenon, or class of phenomena, being thus prepared, the next object is, by a comparison of the different facts, to find out the cause of the phenomenon, its *form*, in the language of Bacon, or its *essence*. The form of any quality in body is something convertible with that quality; that is, where it exists, the quality is present, and where the quality is present, the form must be so likewise. Thus, if transparency in bodies be the thing inquired after, the form of it is something that, wherever it is found, there is transparency; and, *vice versa*, wherever there is transparency, that which we have called the form is likewise present.

The form, then, differs in nothing from the cause; only we apply the word cause where it is event or change that is the effect. When the effect or result is a permanent quality, we speak of the form or essence.

Two other objects, subordinate to *forms*, but often essential to the knowledge of them, are also occasionally subjects of investigation. These are the latent process, and the latent schematism; *latens processus, et latens schematismus*. The former is the secret and invisible progress by which sensible changes are brought about, and seems, in Bacon's acceptation, to involve the principle, since called the *law of continuity*, according to which, no change, however small, can be effected but in *time*. To know the relation between the time and the change effected in it, would be to have a perfect knowledge of the latent process. In the firing of a cannon, for example, the succession of events during the short interval between the application of the match and the expulsion of the ball, constitutes a latent process of a very remarkable and complicated nature, which, however, we can now trace with some degree of accuracy. In mechanical operations, we can often follow this process still more completely. When motion is communicated from any body to another,

it is distributed through all the parts of that other, by a law quite beyond the reach of sense to perceive directly, but yet subject to investigation, and determined by a principle, which, though late of being discovered, is now generally recognised. The applications of this mechanical principle are perhaps the instances in which a latent, and, indeed, a very recondite process, has been most completely analyzed.

The latent schematism is that invisible structure of bodies, on which so many of their properties depend. When we inquire into the constitution of crystals, or into the internal structure of plants, &c. we are examining into the latent schematism. We do the same when we attempt to explain elasticity, magnetism, gravitation, &c. by any peculiar structure of bodies, or any arrangement of the particles of matter.¹

In order to inquire into the *form* or cause of any thing by induction, having brought together the facts, we are to begin with considering what things are thereby excluded from the number of possible forms. This exclusion is the first part of the process of induction: it confines the field of hypothesis, and brings the true explanation within narrower limits. Thus, if we were inquiring into the quality which is the cause of transparency in bodies; from the fact that the diamond is transparent, we immediately exclude rarity or porosity as well as fluidity from those causes, the diamond being a very solid and dense body.

Negative instances, or those where the given *form* is wanting, are also to be collected.

That glass, when pounded, is not transparent, is a negative fact, and of considerable importance when the *form* of transparency is inquired into; also, that collections of vapour, such as clouds and fogs, have not transparency, are negative facts of the same kind. The facts thus collected, both affirmative and negative, may, for the sake of reference, be reduced into tables.

Bacon exemplifies his method on the subject of Heat; and, though his collection of facts be imperfect, his method of treating them is extremely judicious, and the whole disquisition highly interesting.² He here proposes, as an experiment, to try the reflection of the heat of opaque bodies.³ He mentions also the *vitrum calendare*, or thermometer, which was just then coming into use. His reflections, after finishing his enumeration of facts, show how sensible he was of the imperfect state of his own knowledge.⁴

After a great number of exclusions have left but a few principles, common to every case,

¹ Nov. Org. Lib. ii. Aph. 5, 6, &c.

² Ibid. Aph. 18, 20, &c.

³ Ibid. Aph. 11.

⁴ Ibid. Aph. 14.

one of these is to be assumed as the cause ; and, by reasoning from it synthetically, we are to try if it will account for the phenomena.

So necessary did this exclusive process appear to Bacon, that he says, " It may perhaps be competent to angels, or superior intelligences, to determine the form or essence directly, by affirmations from the first consideration of the subject. But it is certainly beyond the power of man, to whom it is only given to proceed at first by negatives, and, in the last place, to end in an *affirmative*, after the exclusion of every thing else."¹

The method of induction, as laid down here, is to be considered as applicable to all investigations where experience is the guide, whether in the moral or natural world. " Some may doubt whether we propose to apply our method of investigation to natural philosophy only, or to other sciences, such as logic, ethics, politics. We answer, that we mean it to be so applied. And as the common logic, which proceeds by the syllogism, belongs not only to natural philosophy, but to all the sciences, so our logic, which proceeds by induction, embraces every thing."²

Though this process had been pursued by a person of much inferior penetration and sagacity to Bacon, he could not but have discovered that all facts, even supposing them truly and accurately recorded, are not of equal value in the discovery of truth. Some of them show the thing sought for in its highest degree, some in its lowest ; some exhibit it simple and uncombined, in others it appears confused with a variety of circumstances. Some facts are easily interpreted, others are very obscure, and are understood only in consequence of the light thrown on them by the former. This led our author to consider what he calls *Prerogativæ Instantiarum*, the comparative value of facts as means of discovery, or as instruments of investigation. He enumerates twenty-seven different species, and enters at some length into the peculiar properties of each. I must content myself, in this sketch, with describing a few of the most important, subjoining, as illustrations, sometimes the examples which the author himself has given, but more frequently such as have been furnished by later discoveries in science.

I. The first place in this classification is assigned to what are called *instantiæ solitariae*, which are either examples of the same quality existing in two bodies, which have nothing in common but that quality, or of a quality differing in two bodies, which are in all other respects the same. In the first instance, the bodies differ in all things but one ; in the second, they agree in all but one. The *hypotheses* that in either case can be entertained,

¹ Nov. Org. Lib. ii. Aph. 15.

² Ibid. Lib. i. Aph. 127.

concerning the cause or *form* of the said quality, are reduced to a small number ; for, in the first, they can involve none of the things in which the bodies differ ; and, in the second, none of those in which they agree.

Thus, of the cause or *form* of colour now inquired into, *instantiæ solitariae* are found in crystals, prisms of glass, drops of dew, which occasionally exhibit colour, and yet have nothing in common with the stones, flowers, and metals, which possess colour permanently, except the colour itself. Hence Bacon concludes, that colour is nothing else than a modification of the rays of light, produced, in the first case, by the different degrees of incidence ; and, in the second, by the texture or constitution of the surfaces of bodies. He may be considered as very fortunate in fixing on these examples, for it was by means of them that Newton afterwards found out the composition of light.

Of the second kind of *instantiæ solitariae*, Bacon mentions the white or coloured veins which occur in limestone or marble, and yet hardly differ in substance or in structure from the ground of the stone. He concludes, very justly, from this, that colour has not much to do with the essential properties of body.

II. The *instantiæ migrantes* exhibit some *nature* or property of body, passing from one condition to another, either from less to greater, or from greater to less ; arriving nearer perfection in the first case, or verging towards extinction in the second.

Suppose the thing inquired into were the cause of whiteness in bodies ; an *instantia migrans* is found in glass, which, when entire, is without colour, but, when pulverized, becomes white. The same is the case with water unbroken, and water dashed into foam. In both cases, the separation into particles produces whiteness. So also the communication of fluidity to metals by the application of heat ; and the destruction of that fluidity by the abstraction of heat, are examples of both kinds of the *instantiæ migrantes*. Instances of this kind are very powerful for reducing the cause inquired after into a narrow space, and for removing all the accidental circumstances. It is necessary, however, as Bacon¹ very justly remarks, that we should consider not merely the case when a certain quality is lost, and another produced, but the gradual changes made in those qualities during their migration, viz. the increase of the one, and the corresponding diminution of the other. The quantity which changes proportionally to another, is connected with it either as cause and effect, or as a collateral effect of the same cause. When, again, we find two

¹ Nov. Org. Lib. ii. Aph. 23.

qualities which do not increase proportionally, they afford a negative instance, and assure us that the two are not connected simply as cause and effect.

The mineral kingdom is the great theatre of the *instantiæ migrantes*, where the same nature is seen in all gradations, from the most perfect state, till it become entirely evanescent. Such are the shells which we see so perfect in figure and structure in limestone, and gradually losing themselves in the finer marbles, till they can no longer be distinguished. The use, also, of one such fact to explain or interpret another, is nowhere so well seen as in the history of the mineral kingdom.

III. In the third place are the *instantiæ ostensivæ*, which Bacon also calls *elucescentiæ* and *predominantes*. They are the facts which show some particular nature in its highest state of power and energy, when it is either freed from the impediments which usually counteract it, or is itself of such force as entirely to repress those impediments. For as every body is susceptible of many different conditions, and has many different forms combined in it, one of them often confines, depresses, and hides another entirely, so that it is not easily distinguished. There are found, however, some subjects in which the nature inquired into is completely displayed, either by the absence of impediments, or by the predominance of its own power.

Bacon instances the thermometer, or *vitrum calendare*, as exhibiting the expansive power of heat, in a manner more distinct and measurable than in common cases. To this example, which is well chosen, the present state of science enables us to add many others.

If the weight of the air were inquired into, the Torricellian experiment or the barometer affords an *ostensive instance*, where the circumstance which conceals the weight of the atmosphere in common cases, namely, the pressure of it in all directions, being entirely removed, that weight produces its full effect, and sustains the whole column of mercury in the tube. The barometer affords also an example of the *instantia migrans*, when the change is not total, but only partial, or progressive. If it be the weight of the air which supports the mercury in the tube of the barometer, when that weight is diminished, the mercury ought to stand lower. On going to the top of a mountain, the weight of the incumbent air is diminished, because a shorter column of air is to be sustained; the mercury in the barometer ought therefore to sink, and it is found to do so accordingly.

These are instances in which the action of certain principles is rendered visible by the removal of all the opposing forces. One may be given where it is the distinct and decisive nature of the fact which leads to the result.

Suppose it were inquired, whether the present land had ever been covered by the sea.

If we look at the stratified form of so large a portion of the earth's surface, we cannot but conclude it to be very probable that such land was formed at the bottom of the sea. But the decisive proof is afforded by the shells and corals, or bodies having the perfect shape of shells and corals, and of other marine exuviæ, which are found imbedded in masses of the most solid rock, and often on the tops of very high mountains. This leaves no doubt of the formation of the land under the sea, though it does not determine whether the land, since its formation, has been elevated to its present height, or the sea depressed to its present level. The decision of that question requires other facts to be consulted.

IV. The *instantia clandestina*, which is, as it were, opposed to the preceding, and shows some power or quality just as it is beginning to exist, and in its weakest state, is often very useful in the generalization of facts. Bacon also gave to this the fanciful name of *instantia crepusculi*.

An example of this may be given from hydrostatics. If the suspension of water in capillary tubes be inquired into, it becomes very useful to view that effect when it is least, or when the tube ceases to be capillary, and becomes a vessel of a large diameter. The column is then reduced to a slender ring of water which goes all round the vessel, and this, though now so inconsiderable, has the property of being independent of the size of the vessel, so as to be in all cases the same when the materials are the same. As there can be no doubt that this ring proceeds from the attraction of the sides, and of the part immediately above the water, so there can be no doubt that the capillary suspension, in part at least, is derived from the same cause. An effect of the opposite kind takes place when a glass vessel is filled with mercury.

V. Next to these may be placed what are called *instantiæ manipulares*, or collective instances, that is, general facts, or such as comprehend a great number of particular cases. As human knowledge can but seldom reach the most general cause or *form*, such collective instances are often the utmost extent to which our generalization can be carried. They have great value on this account, as they likewise have on account of the assistance which they give to farther generalization.

Of this we have a remarkable instance in one of the most important steps ever taken in any part of human knowledge. The laws of Kepler are facts of the kind now treated of, and consist of three general truths, each belonging to the whole planetary system, and it was by means of them that Newton discovered the principle of gravitation. The first is, that the planets all move in elliptical orbits, having the sun for their common focus; the next, that about this focus the *radius vector* of each planet describes equal

areas in equal times. The third and last, that the squares of the periodic times of the planets are as the cubes of their mean distances from the sun. The knowledge of each of these was the result of much research, and of the comparison of a vast multitude of observations, insomuch that it may be doubted if ever three truths in science were discovered at the expence of so much labour and patience, or with the exertion of more ingenuity and invention in imagining and combining observations. These discoveries were all made before Bacon wrote, but he is silent concerning them; for the want of mathematical knowledge concealed from his view some of the most splendid and interesting parts of science.

Astronomy is full of such collective instances, and affords them, indeed, of the second and third order, that is to say, two or three times generalized. The astronomer observes nothing but that a certain luminous disk, or perhaps merely a luminous point, is in a certain position, in respect of the planes of the meridian and the horizon, at a certain moment of time. By comparing a number of such observations, he finds that this luminous point moves in a certain plane, with a certain velocity, and performs a revolution in a certain time. Thus, the periodic time of a planet is itself a collective fact, or a single fact expressing the result of many hundred observations. This holds with respect to each planet, and with respect to each element, as it is called, of the planet's orbit, every one of which is a general fact, expressing the result of an indefinite number of particulars. This holds still more remarkably of the inferences which extend to the distances of the planet from the earth, or from the sun. The laws of Kepler are therefore collective facts of the second, or even a higher order; or such as comprehend a great number of general facts, each of which is itself a general fact, including many particulars. It is much to the credit of astronomy, that, in all this process, no degree of truth or certainty is sacrificed; and that the same demonstrative evidence is preserved from the lowest to the highest point. Nothing but the use of mathematical reasoning could secure this advantage to any of the sciences.

VI. In the next place may be ranked the instances which Bacon calls *analogous*, or *parallel*. These consist of facts, between which an analogy or resemblance is visible in some particulars, notwithstanding great diversity in all the rest. Such are the telescope and microscope, in the works of art, compared with the eye in the works of nature. This, indeed, is an analogy which goes much beyond the mere exterior; it extends to the internal structure, and to the principle of action, which is the same in the eye and in the telescope,—to the *latent schematism*, in the language of Bacon, as far as material substance is concerned. It was the experiment of the *camera obscura* which led to the

discovery of the formation of the images of external objects in the bottom of the eye by the action of the crystalline lens, and the other humours of which the eye is formed.

Among the instances of conformity, those are the most useful which enable us to compare productions of an unknown formation, with similar productions of which the formation is well understood. Such are basalt, and the other trap rocks, compared with the lava thrown out from volcanoes. They have a structure so exactly similar, that it is hardly possible to doubt that their origin is the same, and that they are both produced by the action of subterraneous fire. There are, however, amid their similarity, some very remarkable differences in the substances which they contain, the trap rocks containing calcareous spar, and the lava never containing any. On the supposition that they are both of igneous origin, is there any circumstance, in the conditions in which heat may have been applied to them, which can account for this difference? Sir James Hall, in a train of most philosophical and happily contrived experiments, has explained the nature of those conditions, and has shown that the presence of calcareous spar, or the want of it, may arise from the greater or less compression under which the fusion of the basalt was performed. This has served to explain a great difficulty in the history of the mineral kingdom.

Comparative anatomy is full of analogies of this kind, which are most instructive, and useful guides to discovery. It was by remarking in the blood-vessels a contrivance similar to the valves used in hydraulic engines, for preventing the counter current of a fluid, that Harvey was led to the discovery of the circulation of the blood. The analogies between natural and artificial productions are always highly deserving of notice.

The facts of this class, however, unless the analogy be very close, are apt to mislead, by representing accidental regularity as if it were constant. Of this we have an example in the supposed analogy between the colours in the prismatic spectrum and the divisions of the monochord. The colours in the prismatic spectrum do not occupy the same proportion of it in all cases: the analogy depends on the particular kind of glass, not on any thing that is common to all refraction. The tendency of man to find more order in things than there actually exists, is here to be cautiously watched over.

VII. *Monodie*, or singular facts, are the next in order. They comprehend the instances which are particularly distinguished from all those of the genus or species to which they belong. Such is the sun among the stars, the magnet among stones, mercury among metals, boiling fountains among springs, the elephant among quadrupeds. So also among the planets, Saturn is singular from his ring, the new planets are so likewise from their small size, from being extrazodiacal, &c.

Connected with these are the irregular and deviating instances, in which nature seems to depart from her ordinary course. Earthquakes, extraordinary tempests, years of great scarcity, winters of singular severity, &c. are of this number. All such facts ought to be carefully collected; and there should be added an account of all monstrous productions, and of every thing remarkable for its novelty and its rareness. Here, however, the most severe criticism must be applied; every thing connected with superstition is suspicious, as well as whatever relates to alchemy or magic.

A set of facts, which belongs to this class, consists of the instances in which *stones* have so often of late years been observed to fall from the heavens. Those stones are so unlike other atmospherical productions, and their origin must be so different from that of other minerals, that it is scarcely possible to imagine any thing more anomalous, and more inconsistent with the ordinary course of our experience. Yet the existence of this phenomenon is so well authenticated by testimony, and by the evidence arising from certain physical considerations, that no doubt with respect to it can be entertained, and it must therefore be received, as making a part of the natural history of meteors. But as every fact, or class of facts, which is perfectly singular, must be incapable of explanation, and can only be understood when its resemblance to other things has been discovered, so at present we are unable to assign the cause of these phenomena, and have no right to offer any theory of their origin.

VIII. Another class of facts is composed of what Bacon calls *instantiæ comitatus*, or examples of certain qualities which always accompany one another. Such are flame and heat,—flame being always accompanied by heat, and the same degree of heat in a given substance being always accompanied with flame. So also heat and expansion,—an increase of heat being accompanied with an increase of volume, except in a very few cases, and in circumstances very particular.

The most perfect *instantia comitatus* known, as being without any negative, is that of body and weight. Whatever is impenetrable and inert, is also heavy in a degree proportional to its inertia. To this there is no exception, though we do not perceive the connection as necessary.

Hostile instances, or those of perpetual separation, are the reverse of the former.

Examples of this are found in air, and the other elastic fluids, which cannot have a solid form induced on them by any known means, when not combined with other substances. So also in solids, transparency and malleability are never joined, and appear to be incompatible, though it is not obvious for what reason.

IX. Passing over several classes which seem of inferior importance, we come to the *in-*

stantia crucis, the division of this experimental logic which is most frequently resorted to in the practice of inductive investigation. When, in such an investigation, the understanding is placed in *equilibrio*, as it were, between two or more causes, each of which accounts equally well for the appearances, as far as they are known, nothing remains to be done but to look out for a fact which can be explained by the one of these causes, and not by the other; if such a one can be found, the uncertainty is removed, and the true cause is determined. Such facts perform the office of a cross, erected at the separation of two roads, to direct the traveller which he is to take, and, on this account, Bacon gave them the name of *instantiæ crucis*.

Suppose that the subject inquired into were the motion of the planets, and that the phenomena which first present themselves, or the motion of these bodies in longitude, could be explained equally on the Ptolemaic and the Copernican system, that is, either on the system which makes the Earth, or that which makes the Sun, the centre of the planetary motions, a cautious philosopher would hesitate about which of the two he should adopt, and notwithstanding that one of them was recommended by its superior simplicity, he might not think himself authorized to give to it a decided preference above the other. If, however, he consider the motion of these bodies in latitude, that is to say, their digressions from the plane of the ecliptic, he will find a set of phenomena which cannot be reconciled with the supposition that the earth is the centre of the planetary motions, but which receive the most simple and satisfactory explanation from supposing that the sun is at rest, and is the centre of those motions. The latter phenomena would therefore serve as *instantiæ crucis*, by which the superior credibility of the Copernican system was fully evinced.

Another example which I shall give of an *instantia crucis* is taken from chemistry, and is, indeed, one of the most remarkable experiments which has been made in that science.

It is a general fact observed in chemistry, that metals are always rendered heavier by calcination. When a mass of tin or lead, for instance, is calcined in the fire, though every precaution is taken to prevent any addition from the adhesion of ashes, coals, &c. the absolute weight of the mass is always found to be increased. It was long before the cause of this phenomenon was understood. There might be some heavy substance added, though what it was could not easily be imagined; or some substance might have escaped, which was in its nature light, and possessed a tendency upwards. Other phenomena, into the nature of which it is at present unnecessary to inquire, induced chemists to suppose, that in calcination a certain substance actually escapes, being present in the regulus, but not in

the calx of the metal. This substance, to which they gave the name of phlogiston, was probably that which, by its escape, rendered the metal heavier, and must, therefore, be itself endued with absolute levity.

The *instantia crucis* which extricated philosophers from this difficulty, was furnished by an experiment of the celebrated Lavoisier. That excellent chemist included a quantity of tin in a glass retort, hermetically sealed, and accurately weighed together with its contents; he then applied the necessary heat, and when the calcination of the tin was finished, he found the weight of the whole precisely the same as before. This proved, that no substance, which was either light or heavy, in a sensible degree, had made its way through the glass. The experiment went still farther. When the retort was cooled and opened, the air rushed in, so that it was evident that a part of the air had disappeared, or had lost its elasticity. On weighing the whole apparatus, it was now found that its weight was increased by ten grains; so that ten grains of air had entered into the retort when it was opened. The calx was next taken out, and weighed separately, and it was found to have become heavier by ten grains precisely. The ten grains of air then which had disappeared, and which had made way for the ten grains that rushed into the retort, had combined with the metal during the process of calcination. The farther prosecution of this very decisive experiment led to the knowledge of that species of air which combines with metals when they are calcined. The doctrine of phlogiston was of course exploded, and a creature of the imagination replaced by a real existence.

The principle which conducts to the contrivance of an *experimentum crucis* is not difficult to be understood. Taking either of the hypotheses, its consequences must be attempted to be traced, supposing a different experiment to be made. This must be done with respect to the other hypothesis, and a case will probably at last occur, where the two hypotheses would give different results. The experiment made in those circumstances will furnish an *instantia crucis*.

Thus, if the experiment of calcination be performed in a close vessel, and if phlogiston be the cause of the increase of weight, it must either escape through the vessel, or it must remain in the vessel after separation from the calx. If the former be the case, the apparatus will be increased in weight; if the latter, the phlogiston must make its escape on opening the vessel. If neither of these be the case, it is plain that the theory of phlogiston is insufficient to explain the facts.

The *experimentum crucis* is of such weight in matters of induction, that in all those branches of science where it cannot easily be resorted to (the circumstances of an experiment being out of our power, and incapable of being varied at pleasure), there is often a

great want of conclusive evidence. This holds of agriculture, medicine, political economy, &c. To make one experiment, similar to another in all respects but one, is what the *experimentum crucis*, and, in general, the process of induction, principally requires; but it is what, in the sciences just named, can seldom be accomplished. Hence the great difficulty of separating the causes, and allotting to each its due proportion of the effect. Men deceive themselves in consequence of this continually, and think they are reasoning from fact and experience, when, in reality, they are only reasoning from a mixture of truth and falsehood. The only end answered by facts so incorrectly apprehended, is that of making error more incorrigible.

Of the twenty-seven classes into which *instantiæ* are arranged by the author of the *Novum Organum*, fifteen immediately address themselves to the Understanding; five serve to correct or to inform the Senses; and seven to direct the hand in raising the superstructure of Art on the foundation of Science. The examples given above are from the first of these divisions, and will suffice for a summary. To the five that follow next, the general name of *instantiæ lampadis* is given, from their office of assisting or informing the senses.

Of these the *instantiæ januæ* assist the immediate action of the senses, and especially of sight. The examples quoted by Bacon are the microscope and telescope (which last he mentions as the invention of Galileo), and he speaks of them with great admiration, but with some doubt of their reality.

The *instantiæ citantes* enable us to perceive things which are in themselves insensible, or not at all the objects of perception. They cite or place things, as it were, before the bar of the senses, and from this analogy to judicial proceedings is derived the name of *instantiæ citantes*. Such, to employ examples which the progress of science has unfolded since the time of Bacon, are the air-pump and the barometer for manifesting the weight and elasticity of air; the measurement of the velocity of light, by means of the eclipses of the satellites of Jupiter, and the aberration of the fixed stars; the experiments in electricity and Galvanism, and in the greater part of pneumatic chemistry. In all these instances things are made known which before had entirely escaped the senses.

The *instantiæ viæ* are facts which manifest the continuous progress of nature in her operations. There is a propensity in men to view nature as it were at intervals, or at the ends of fixed periods, without regarding her gradual and unceasing action.¹ The desire

¹ Nov. Org. II. Aph. 41.

of making observation easy is the great source of this propensity. Men wish for knowledge, but would obtain it at the least expence of time and labour. As there is no time, however, at which the hand of nature ceases to work, there ought to be none at which observation ceases to be made.

The *instantiæ persecantes*, or *vellicantes*, are those which force us to attend to things which, from their subtlety and minuteness, escape common observation.

Some of Bacon's remarks on this subtlety are such as would do credit to the most advanced state of science, and show how much his mind was fitted for distinguishing and observing the great and admirable in the works of nature.

The last division contains seven classes, of which I mention only two. The experiments of this division are those most immediately tending to produce the improvement of art from the extension of science. "Now there are," says Bacon, "two ways in which knowledge, even when sound in itself, may fail of becoming a safe guide to the artist, and these are either when it is not sufficiently precise, or when it leads to more complicated means of producing an effect than can be employed in practice. There are therefore two kinds of experiments which are of great value in promoting the alliance between knowledge and power;—those which tend to give accurate and exact measures of objects, and those which disencumber the processes deduced from scientific principles of all unnecessary operations."

In the *instantiæ radii* we measure objects by lines and angles; in the *instantiæ curricula* by time or by motion.

To the former of these classes are to be referred a number of instruments which now constitute the greater part of the apparatus of natural philosophy. Though Bacon had a just idea of their utility in general, he was unacquainted with most of them. The most remarkable at present are those that follow:

1. Astronomical instruments, or, more generally, all instruments for measuring lines and angles.

2. Instruments for measuring weight or force; such are the common balance, the hydrostatic balance, the barometer, the instruments used in England by Cavendish, and in France by Coulomb, which measure small and almost insensible actions by the force of torsion.

These last rather belong to the class of the *instantiæ luctæ*, where force is applied as the measure of force, than to the *instantiæ radii*.

3. The thermometer, newly invented in the time of Bacon, and mentioned by him un-

der the name of *Vitrum Calendare*, an instrument to which we owe nearly all the knowledge we have of one of the most powerful agents in nature, viz. Heat.

4. The hygrometer, an instrument for measuring the quantity of humidity contained in the air; and in the construction of which, after repeated failures by the most skilful experimenters, the invention of Professor Leslie now promises success. Almost every one of these instruments, to which several more might be added, has brought in sight a new country, and has enriched science not only with new facts, but with new principles.

Among the remarks of Bacon on the *experimenta radii*, some are very remarkable for the extent of view which they display even in the infancy of physical science. He mentions the forces by which bodies act on one another at a distance, and throws out some hints at the attraction which the heavenly bodies exert on one another.

“Inquirendum est,” says he, “si sit vis aliqua magnetica quæ operetur per consensum inter globum terræ et ponderosa, aut inter globum lunæ et aquas maris, aut inter cœlum stellatum, et planetas per quam avocentur et atollantur ad sua apogæa; hæc omnia operantur ad distantias admodum longinquas.”¹

Under the head of the *instantia curriculi*, or the measuring of things by time; after remarking that every change and every motion requires time, and illustrating this by a variety of instances, he has the following very curious anticipation of facts, which appeared then doubtful, but which subsequent discovery has ascertained:

“The consideration of those things produced in me a doubt altogether astonishing, viz. Whether the face of the serene and starry heavens be seen at the instant it really exists, or not till some time later; and whether there be not, with respect to the heavenly bodies, a true time and an apparent time, no less than a true place, and an apparent place, as astronomers say, on account of parallax. For it seems incredible that the *species* or rays of the celestial bodies can pass through the immense interval between them and us in an instant, or that they do not even require some considerable portion of time.”²

The measurement of the velocity of light, and the wonderful consequences arising from it, are the best commentaries on this passage, and the highest eulogy on its author.

Such were the speculations of Bacon, and the rules he laid down for the conduct of experimental inquiries, before any such inquiries had yet been instituted. The power and compass of a mind which could form such a plan beforehand, and trace not merely the

¹ Nov. Org. II. Aph. 45.

² Ibid. Aph. 46.

outline, but many of the most minute ramifications, of sciences which did not yet exist, must be an object of admiration to all succeeding ages. He is destined, if, indeed, any thing in the world be so destined, to remain an *instantia singularis* among men, and as he has had no rival in the times which are past, so is he likely to have none in those which are to come. Before any parallel to him can be found, not only must a man of the same talents be produced, but he must be placed in the same circumstances; the memory of his predecessor must be effaced, and the light of science, after being entirely extinguished, must be again beginning to revive. If a second Bacon is ever to arise, he must be ignorant of the first.

Bacon is often compared with two great men who lived nearly about the same time with himself, and who were both eminent reformers of philosophy, Descartes and Galileo.

Descartes flourished about forty years later than Bacon, but does not seem to have been acquainted with his writings. Like him, however, he was forcibly struck with the defects of the ancient philosophy, and the total inaptitude of the methods which it followed, for all the purposes of physical investigation. Like him, too, he felt himself strongly impelled to undertake the reformation of this erroneous system; but the resemblance between them goes no farther; for it is impossible that two men could pursue the same end by methods more diametrically opposite.

Descartes never proposed to himself any thing which had the least resemblance to induction. He began with establishing principles, and from the existence of the Deity and his perfections, he proposed to deduce the explanation of all the phenomena of the world, by reasoning *a priori*. Instead of proceeding upward from the effect to the cause, he proceeded continually downward from the cause to the effect. It was in this manner that he sought to determine the laws of motion, and of the collision of bodies, in which last all his conclusions were erroneous. From the same source he deduced the existence of a *plenum*, and the continual preservation of the same quantity of motion in the universe; a proposition which, in a certain sense, is true, but in the sense in which he understood it, is altogether false. Reasonings of the kind which he employed may possibly suit, as Bacon observed, with intelligences of a higher order than man, but to his case they are quite inapplicable. Of the fruit of this tree nature has forbidden him to eat, and has ordained, that, with the sweat of his brow, and the labour of his hands, he should earn his knowledge as well as his subsistence.

Descartes, however, did not reject experiment altogether, though he assigned it a very subordinate place in his philosophy. By reasoning down from first principles, he tells us that he was always able to discover the effects; but the number of different shapes which

those effects might assume was so great, that he could not determine, without having recourse to experiment, which of them nature had preferred to the rest. "We employ experiment," says he, "not as a reason by which any thing is proved, for we wish to deduce effects from their causes, and not conversely causes from their effects. We appeal to experience only, that out of innumerable effects which may be produced from the same cause, we may direct our attention to one rather than another." It is wonderful, that Descartes did not see what a severe censure he was here passing on himself; of how little value the speculations must be that led to conclusions so vague and indefinite; and how much more philosophy is disgraced by affording an explanation of things which *are not*, than by *not* affording an explanation of things which *are*.

As a system of philosophy and philosophic investigation, the method of Descartes can, therefore, stand in no comparison with that of Bacon. Yet his physics contributed to the advancement of science, but did so, much more by that which they demolished, than by that which they built up. In some particular branches the French philosopher far excelled the English. He greatly improved the science of optics, and in the pure mathematics, as has been already shown, he left behind him many marks of a great and original genius. He will, therefore, be always numbered among those who have essentially contributed to the advancement of knowledge, though nothing could be more perverse than his method of philosophizing, and nothing more likely to impede the progress of science, had not an impulse been at that time given to the human mind which nothing could resist.

Galileo, the other rival and contemporary of Bacon, is, in truth, one of those to whom human knowledge is under the greatest obligations. His discoveries in the theory of motion, in the laws of the descent of heavy bodies, and in the motion of projectiles, laid the foundation of all the great improvements which have since been made by the application of mathematics to natural philosophy. If to this we add the invention of the telescope, the discoveries made by that instrument, the confirmations of the Copernican system which these discoveries afforded, and, lastly, the wit and argument with which he combated and exposed the prejudice and presumption of the schools, we must admit that the history of human knowledge contains few greater names than that of Galileo. On comparing him with Bacon, however, I have no hesitation in saying, that the latter has given indications of a genius of a still higher order. In this I know that I differ from a historian, who was himself a philosopher, and whose suffrage, of consequence, is here of more than ordinary weight.

"The great glory of literature," says Hume, "in this island, during the reign of

James, was Lord Bacon. If we consider the variety of talents displayed by this man, as a public speaker, a man of business, a wit, a courtier, a companion, an author, a philosopher, he is justly entitled to great admiration. If we consider him merely as an author and a philosopher, the light in which we view him at present, though very estimable, he was yet inferior to his contemporary Galileo, perhaps even to Kepler. Bacon pointed out, at a distance, the road to philosophy; Galileo both pointed it out to others, and made himself considerable advances in it. The Englishman was ignorant of geometry; the Florentine revived that science, excelled in it, and was the first who applied it, together with experiment, to natural philosophy. The former rejected, with the most positive disdain, the system of Copernicus; the latter fortified it with new proofs, derived both from reason and the senses. Bacon's style is stiff and rigid; his wit, though often brilliant, is also often unnatural and far-fetched. Galileo is a lively and agreeable, though somewhat a prolix writer."¹

Though it cannot be denied that there is considerable truth in these remarks, yet it seems to me that the comparison is not made with the justness and discrimination which might have been expected from Hume, who appears studiously to have contrasted what is most excellent in Galileo, with what is most defective in Bacon. It is true that Galileo showed the way in the application of mathematics and of geometry to physical investigation, and that the immediate utility of his performance was greater than that of Bacon's; as it impressed more movement on the age in which he lived, example being always so much more powerful than precept. Bacon, indeed, wrote for an age more enlightened than his own, and it was long before the full merit of his work was understood. But though Galileo was a géométer, and Bacon unacquainted with the mathematics,—though Galileo added new proofs to the system of the earth's motion, which Bacon rejected altogether,—yet is it certain, I think, that the former has more fellows or equals in the world of science than the latter, and that his excellence, though so high, is less unrivalled. The range which Bacon's speculations embraced was altogether immense. He cast a penetrating eye on the whole of science, from its feeblest and most infantine state, to that strength and perfection from which it was then so remote, and which it is perhaps destined to approach to continually, but never to attain. More substitutes might be found for Galileo than for Bacon. More than one could be mentioned, who, in the place of the former, would probably have done what he did; but the history of human knowledge points out nobody of whom it can be said, that, placed in the situation of Bacon, he would have

¹ Hist. of England, Vol. VI. Appendix.

done what Bacon did;—no man whose prophetic genius would have enabled him to delineate a system of science which had not yet begun to exist!—who could have derived the knowledge of what *ought to be* from what *was not*, and who could have become so rich in wisdom, though he received from his predecessors no inheritance but their errors. I am inclined, therefore, to agree with D'Alembert, “that when one considers the sound and enlarged views of this great man, the multitude of the objects to which his mind was turned, and the boldness of his style, which unites the most sublime images with the most rigorous precision, one is disposed to regard him as the greatest, the most universal, and the most eloquent of philosophers.”¹

3. REMARKS, &c.

It will hardly be doubted by any one who attentively considers the method explained in the *Novum Organum*, which we have now attempted to sketch, that it contains a most comprehensive and rigorous plan of inductive investigation. A question, however, may occur, how far has this method been really carried into practice by those who have made the great discoveries in natural philosophy, and who have raised physical science to its present height in the scale of human knowledge? Is the whole method necessary, or have not circumstances occurred, which have rendered experimental investigation easier in practice than it appears to be in theory? To answer these questions completely, would require more discussion than is consistent with the limits of this Dissertation; I shall, therefore, attempt no more than to point out the principles on which such an answer may be founded.

In a very extensive department of physical science, it cannot be doubted that investigation has been carried on, not perhaps more easily, but with a less frequent appeal to experience, than the rules of the *Novum Organum* would seem to require. In all the physical inquiries where mathematical reasoning has been employed, after a few principles have been established by experience, a vast multitude of truths, equally certain with the principles themselves, have been deduced from them by the mere application of geometry and algebra.

In mechanics, for example, after the laws of motion were discovered, which was done by experiment, the rest of the science, to a great extent, was carried on by reasoning from those laws, in the same manner that the geometer makes his discoveries by reasoning on

¹ Discours Préliminaire de l'Encyclopédie.

the definitions, by help of a few axioms, or self-evident propositions. The only difference is, that, in the one case, the definitions and axioms are supplied solely from the mind itself, while, in the other, all the definitions and axioms, which are not those of pure geometry, are furnished by experience.¹

Bacon certainly was not fully aware of the advantages that were thus to accrue to the physical sciences. He was not ignorant, that the introduction of mathematical reasoning into those sciences is not only possible, but that, under certain conditions, it may be attended with the greatest advantage. He knew also in what manner this application had been abused by the Platonists, who had attempted, by means of geometry, to establish the first principles of physics, or had used them, *in axiomatis constituendis*, which is exactly the province belonging exclusively to experience. At the same time, he pointed out, with great precision, the place which the mathematics may legitimately occupy, as serving to measure and compare the objects of physical inquiry. He did not, however, perceive beforehand, nor was it possible that he should, the vast extent to which the application of that science was capable of being carried. In the book, *De Augmentis*, he has made many excellent remarks on this subject, full of the sagacity which penetrated so far into futurity, but, nevertheless, could only perceive a small part of the scene which the genius of Newton was afterwards to unfold.

Hence, the route which leads to many of the richest and most fertile fields of science, is not precisely that which Bacon pointed out; it is safer and easier, so that the voyager finds he can trust to his chart and compass alone, without constantly looking out, or having the sounding-line perpetually in his hand.

Another remark I must make on Bacon's method is, that it does not give sufficient importance to the *instantiæ radii*, or those which furnish us with accurate measures of physical quantities. The experiments of this class are introduced as only subservient to practice; they are, however, of infinite value in the theoretical part of induction, or for ascertaining the causes and essences of the things inquired into. We have an instance of this in the discovery of that important truth in physical astronomy, that the moon is retained in her orbit by the force of gravity, or the same which, at the earth's surface, makes a stone fall to the ground. This proposition, however it might have been suspected to be true, could never have been demonstrated but by such observations and experiments

¹ The part of mechanics which involves only statical considerations, or the equilibrium of forces, is capable of being treated by *reasoning a priori* entirely, without any appeal to experience. This will appear, when the subject of Mechanics is more particularly treated of.

as assigned accurate geometrical measures to the quantities compared. The semidiameter of the earth; the velocity of falling bodies at the earth's surface; the distance of the moon, and her velocity in her orbit;—all these four elements must be determined with great precision, and afterwards compared together by certain theorems deduced from the laws of motion, before the relation between the force which retains the moon in her orbit, and that which draws a stone to the ground, could possibly be discovered. The discovery also, when made, carried with it the evidence of demonstration, so that here, as in many other cases, the *instantiæ radii* are of the utmost importance in the theoretical part of physics.

Another thing to be observed is, that, in many cases, the result of a number of particular facts, or the collective instance arising from them, can only be found out by geometry, which, therefore, becomes a necessary instrument in completing the work of induction. An example, which the science of optics furnishes, will make this clearer than any general description. When light passes from one transparent medium to another it is refracted, that is, it ceases to go on in a straight line, and the angle which the incident ray makes with the superficies which bounds the two *media*, determines that which the refracted ray makes with the same superficies. Now, if we would learn any thing about the relation which these angles bear to one another, we must have recourse to experiment, and all that experiment can do is, for any particular angle of incidence, to determine the corresponding angle of refraction. This may be done in innumerable cases; but, with respect to the general rule which, in every possible case, determines the one of those angles from the other, or expresses the constant and invariable relation which subsists between them,—with respect to it, experiment gives no direct information. The methods of geometry must therefore be called in to our assistance, which, when a constant though unknown relation subsists between two angles, or two variable quantities of any kind, and when an indefinite number of values of those quantities are given, furnishes infallible means of discovering that unknown relation, either accurately, or at least by approximation. In this way it has been found, that, when the two *media* remain the same, the cosines of the angles above mentioned have a constant ratio to one another. Thus it appears, that, after experiment has done its utmost, geometry must be applied before the business of induction can be completed. This can only happen when the experiments afford accurate measures of the quantities concerned, like the *instantiæ radii*, *curriculi*, &c. and this advantage of admitting generalization with so much certainty is one of their properties, of which it does not appear that even Bacon himself was aware.

Again, from the intimate connection which prevails among the principles of science, the

success of one investigation must often contribute to the success of another, in such a degree as to make it unnecessary to employ the complete apparatus of induction from the beginning. When certain leading principles have been once established, they serve, in new investigations, to narrow the limits within which the thing sought for is contained, and enable the inquirer to arrive more speedily at the truth.

Thus, suppose that, after the nature of the reflection and refraction of light, and particularly of the colours produced by the latter, had been discovered by experiment, the cause of the rainbow were to be inquired into. It would, after a little consideration, appear probable, that the phenomenon to be explained depends on the reflection and refraction of light by the rain falling from a cloud opposite to the sun. Now, since the nature of reflection and refraction are supposed known, we have the principles previously ascertained which are likely to assist in the explanation of the rainbow. We have no occasion, therefore, to enter on the inquiry, as if the powers to be investigated were wholly unknown. It is the combination of them only which is unknown, and our business is to seek so to combine them, that the result may correspond with the appearances. This last is precisely what Newton accomplished, when, by deducing from the known laws of refraction and reflection the breadth of the coloured arch, the diameter of the circle of which it is a part, and the relation of the latter to the place of the spectator and of the sun, he found all these to come out from his calculus, just as they are observed in nature. Thus he proved the truth of his solution by the most clear and irresistible evidence.

The strict method of Bacon is therefore only necessary where the thing to be explained is new, and where we have no knowledge, or next to none, of the powers employed. This is but rarely the case, at least in some of the branches of Physics; and, therefore, it occurs most commonly in actual investigation, that the inquirer finds himself limited, almost from the first outset, to two or three hypotheses, all other suppositions involving inconsistencies which cannot for a moment be admitted. His business, therefore, is to compare the results of these hypotheses, and to consider what consequences may in any case arise from the one that would not arise from the other. If any such difference can be found, and if the matter is a subject of experiment, we have then an *instantia crucis* which must decide the question.

Thus, the *instantia crucis* comes in real practice to be the experiment most frequently appealed to, and that from which the most valuable information is derived.

In executing the method here referred to, the application of much reasoning, and frequently of much mathematical reasoning, is necessary, before any appeal to the experiment can be made, in order to deduce from each of the hypotheses an exact estimate of the con-

sequences to which it leads. Suppose, for instance, that the law by which the magnetic virtue decreases in its intensity, as we recede from its poles, were to be inquired into. It is obvious that the number of hypotheses is here indefinite; and that we have hardly any choice but to begin with the simplest, or with that which is most analogous to the law of other forces propagated from a centre. Whatever law we assume, we must enter into a good deal of geometric reasoning, before a conclusion can be obtained, capable of being brought to the test of experience. The force itself, like all other forces, is not directly perceived, and its effects are not the result of its mere intensity, but of that intensity combined with the figure and magnitude of the body on which its acts; and, therefore, the calculus must be employed to express the measure of the effect, in terms of the intensity and the distance only. This being done, the hypothesis which gives results most nearly corresponding to the facts observed, when the magnet acts on the same body, at different distances, must be taken as the nearest approximation to the truth. We have here an instance of the use of hypothesis in inductive investigation, and, indeed, of the only legitimate use to which it can ever be applied.

It also appears that Bacon placed the ultimate object of philosophy too high, and too much out of the reach of man, even when his exertions are most skilfully conducted. He seems to have thought, that, by giving a proper direction to our researches, and carrying them on according to the inductive method, we should arrive at the knowledge of the essences of the powers and qualities residing in bodies; that we should, for instance, become acquainted with the essence of heat, of cold, of colour, of transparency. The fact, however, is, that, in as far as science has yet advanced, no one essence has been discovered, either as to matter in general, or as to any of its more extensive modifications. We are yet in doubt, whether heat is a peculiar motion of the minute parts of bodies, as Bacon himself conceived it to be; or something emitted or radiated from their surfaces; or lastly, the vibrations of an elastic medium, by which they are penetrated and surrounded. Yet whatever be the form or essence of heat, we have discovered a great number of its properties and its laws; and have done so, by pursuing with more or less accuracy the method of induction. We have also this consolation for the imperfection of our theoretical knowledge, that, in as much as art is concerned, or the possession of power over heat, we have perhaps all the advantages that could be obtained from a complete knowledge of its essence.

An equal degree of mystery hangs over the other properties and modifications of body; light, electricity, magnetism, elasticity, gravity, are all in the same circumstances; and the only advance that philosophy has made toward the discovery of the essences of these qua-

lities or substances is, by exploding some theories, rather than by establishing any,—so true is Bacon's maxim, that the first steps in philosophy necessarily consist in negative propositions. Besides this, in all the above instances the laws of action have been ascertained; the phenomena have been reduced to a few general facts, and in some cases, as in that of gravity, to one only; and for ought that yet appears, this is the highest point which our science is destined to reach.

In consequence of supposing a greater perfection in knowledge than is ever likely to be attained, Bacon appears, in some respects, to have misapprehended the way in which it is ultimately to become applicable to art. He conceives that, if the *form* of any quality were known, we should be able, by inducing that form on any body, to communicate to it the said quality. It is not probable, however, that this would often lead to a more easy and simple process than that which art has already invented. In the case of colour, for example, though ignorant of its *form*, or of the construction of surface which enables bodies to reflect only light of a particular species, yet we know how to communicate that power from one body to another. Nor is it likely, though this structure were known with ever so great precision, that we should be able to impart it to bodies by any means so simple and easy, as by the common process of immersing them in a liquid of a given colour.

In some instances, however, the theories of chemistry have led to improvements of art very conformable to the anticipations of the *Novum Organum*. A remarkable instance of this occurs in the process for bleaching, invented by Berthollet. It had been for some time known, that the combination of the chemical principle of oxygen with the colouring matter in bodies, destroyed, or discharged, the colour; and that, in the common process of bleaching, it was chiefly by the union of the oxygen of the air with the colouring matter in the cloth that this effect was produced. The excellent chemist just named conceived, therefore, that if the oxygen could be presented to the cloth in a dense state, and, at the same time, feebly combined with any other body, it might unite itself to the colouring matter so readily, that the process of bleaching would by that means be greatly accelerated. His skill in chemistry suggested to him a way in which this might easily be done, by immersing the cloth in a liquid containing much oxygen in a loose state, or one in which it was slightly combined with other substances, and the effect followed so exactly, that he was able to perform in a few hours what required weeks, and even months, according to the common process. This improvement, therefore, was a real gift from the sciences to the arts; and came nearly, though not altogether, up to the ideas of Bacon. I suspect

not altogether, because the manner in which oxygen destroys the colour of bodies, or alters the structure of their surfaces, remains quite unknown.

It was natural, however, that Bacon, who studied these subjects theoretically, and saw nowhere any practical result in which he could confide, should listen to the inspirations of his own genius, and ascribe to philosophy a perfection which it may be destined never to attain. He knew, that from what it had not yet done, he could conclude nothing against what it might hereafter accomplish. But after his method has been followed, as it has now been, with greater or less accuracy, for more than two hundred years, circumstances are greatly changed; and the impediments, which, during all that time, have not yielded in the least to any effort, are perhaps never likely to be removed. This may, however, be a rash inference; Bacon, after all, may be in the right; and we may be judging under the influence of the vulgar prejudice, which has convinced men, in every age, that they had nearly reached the farthest verge of human knowledge. This must be left for the decision of posterity; and we should rejoice to think, that judgment will hereafter be given against the opinion which at this moment appears most probable.

SECTION III.

MECHANICS.

1. THEORY OF MOTION.

BEFORE the end of the sixteenth century, mechanical science had never gone beyond the problems which treat of the equilibrium of bodies, and had been able to resolve these accurately, only in the cases which can be easily reduced to the lever. Guido Ubaldi, an Italian mathematician, was among the first who attempted to go farther than Archimedes and the ancients had done in such inquiries. In a treatise which bears the date of 1577, he reduced the pulley to the lever, but with respect to the inclined plane, he continued in the same error with Pappus Alexandrinus, supposing that a certain force must be applied to sustain a body, even on a plane which has no inclination.

Stevinus, an engineer of the Low Countries, is the first who can be said to have passed beyond the point at which the ancients had stopped, by determining accurately the force necessary to sustain a body on a plane inclined at any angle to the horizon. He resolved

also a great number of other problems connected with the preceding, but, nevertheless, did not discover the general principle of the composition of forces, though he became acquainted with this particular case, immediately applicable to the inclined plane.

The remark, that a chain laid on an inclined plane, with a part of it hanging over at top, in a perpendicular line, will be *in equilibrio*, if the two ends of the chain reach down exactly to the same level, led him to the conclusion, that a body may be supported on such a plane by a force which draws in a direction parallel to it, and has to the weight of the body the same ratio that the height of the plane has to its length.

Though it was probably from experience that Stevinus derived the knowledge of this proposition, he attempted to prove the truth of it by reasoning *a priori*. He supposed the two extremities of the chain, when disposed as above, to be connected by a part similar to the rest, which, therefore, must hang down, and form an arch. If in this state, says he, the chain were to move at all, it would continue to move for ever, because its situation, on the whole, never changing, if it were determined to move at one instant, it must be so determined at every other instant. Now, such perpetual motion, he adds, is impossible, and therefore the chain, as here supposed, with the arch hanging below, does not move. But the force of the arch below draws down the ends of the chain equally, because the arch is divided in the middle or lowest point into two parts similar and equal. Take away these two equal forces, and the remaining forces will also be equal, that is, the tendency of the chain to descend along the inclined plane, and the opposite tendency of the part hanging perpendicularly down, are equal, or are *in equilibrio* with one another. Such is the reasoning of Stevinus, which, whether perfectly satisfactory or not, must be acknowledged to be extremely ingenious, and highly deserving of attention, as having furnished the first solution of a problem, by which the progress of mechanical science had been long arrested. The first appearance of his solution is said to have had the date of 1585; but his works, as we now see them, were collected after his death, by his countryman Albert Girard, and published at Leyden in 1634.¹ Some discoveries of Stevinus in hydrostatics will be hereafter mentioned.

The person who comes next in the history of mechanics made a great revolution in the physical sciences. Galileo was born at Pisa in the year 1564. He early applied himself

¹ The edition of Albert Girard is entitled *Oeuvres Mathematiques de Stevins*, in folio. See Livre I. *De la Statique*, theorem 11. Stevinus also wrote a treatise on navigation, which was published in Flemish in 1586, and was afterwards honoured with a translation into Latin, by Grotius. The merit of Stevinus has been particularly noticed by La Grange. *Mecanique Analytique*, Tom. I. Sect. 1. § 5.

to the study of mathematics and natural philosophy ; and it is from the period of his discoveries that we are to date the joint application of experimental and geometrical reasoning to explain the phenomena of nature.

As early as 1592 he published a treatise, *della Scienza Mechanica*, in which he has given the theory, not of the lever only, but of the inclined plane and the screw ; and has also laid down this general proposition, that mechanical engines make a small force equivalent to a great one, by making the former move over a greater space in the same time than the latter, just in proportion as it is less. No contrivance can make a small weight put a great one in motion, but such a one as gives to the small weight a velocity which is as much greater than that of the large weight, as this last weight is greater than the first. These general propositions, and their influence on the action of machinery, Galileo proceeded to illustrate with that clearness, simplicity, and extent of view, in which he was quite unrivalled ; and hence, I think, it is fair to consider him as the first person to whom the mechanical principle, since denominated that of *the virtual velocities*, had occurred in its full extent. The object of his consideration was the action of machines in motion, and not merely of machines *in equilibrio*, or at rest ; and he showed, that, if the effect of a force be estimated by the weight it can raise to a given height in a given time, this effect can never be increased by any mechanical contrivance whatsoever.

In the same treatise, he lays it down as a postulate (*supposizione*), that the effect of one heavy body to turn another round a centre of motion, is proportional to the perpendicular drawn from that centre to the vertical passing through the body, or in general to the direction of the force. This proposition he states without a demonstration, and passes by means of it to the oblique lever, and thence to the inclined plane. To speak strictly, however, the demonstrations with respect to both these last are incomplete, the preceding proposition being assumed in them without proof. It is probable that he satisfied himself of the truth of it, on the principle, that the distances of forces from the centre of motion must always be measured by lines making the *same* angles with their directions, and that of such lines the simplest are the perpendiculars. His demonstration is regarded by La Grange as quite satisfactory.¹

Galileo extended the theory of motion still farther. He had begun, while pursuing his studies at the university of Pisa, to make experiments on the descent of falling bodies, and discovered the fact, that heavy and light bodies fall to the ground from the same

¹ *Mecanique Analytique*, Tom I. Sect. 1. § 6.

height in the same time, or in times so nearly the same, that the difference can only be ascribed to the resistance of the air. From observing the vibrations of the lamps in the cathedral, he also arrived at this very important conclusion in mechanics, that the great and the small vibrations of the same pendulum are performed in the same time, and that this time depends only on the length of the pendulum. The date of these observations goes back as far as the year 1583.

These experiments drew upon him the displeasure of his masters, who considered it as unbecoming of their pupil to seek for truth in the Book of Nature, rather than in the writings of Aristotle, when elucidated by their commentaries, and, from that moment began the persecutions with which the prejudice, the jealousy, and bigotry of his contemporaries continued to harass or afflict this great man throughout his whole life.

That the acceleration of falling bodies is uniform, or, that they receive equal increments of velocity in equal times, he appears first to have assumed as the law which they follow, merely on account of its simplicity. Having once assumed this principle, he showed, by mathematical reasoning, that the spaces descended through must be as the squares of the times, and that the space fallen through in one second is just the half of that which the body would have described in the same time with the velocity last acquired.

The knowledge which he already had of the properties of the inclined plane enabled him very readily to perceive, that a body descending on such a plane must be uniformly accelerated, though more slowly than when it falls directly, and is accelerated by its whole weight. By means of the inclined plane, therefore, he was able to bring the whole theory of falling bodies to the test of experiment, and to prove the truth of his original assumption, the uniformity of their acceleration.

His next step was to determine the path of a heavy body, when obliquely projected. He showed this path to be a parabola; and here, for the first time, occurs the use of a principle which is the same with the composition of motion in its full extent. Galileo, however, gave no name to this principle; he did not enunciate it generally, nor did he give any demonstration of it, though he employed it in his reasonings. The inertia of body was assumed in the same manner; it was, indeed, involved in the uniform acceleration of falling bodies, for these bodies did not lose in one minute the motion acquired in the preceding, but, retaining it, went on continually receiving more.

The theory of the inclined plane had led to the knowledge of this proposition, that, if a circle be placed vertically, the chords of different arches terminating in the lowest point of the circle, are all descended through in the same space of time. This seemed to explain why, in a circle, the great and the small vibrations are of equal duration. Here,

however, Galileo was under a mistake, as the motions in the chord and in the arch are very dissimilar. The accelerating force in the chord remains the same from the beginning to the end, but, in the arch, it varies continually, and becomes, at the lowest point, equal to nothing. The times in the chords, and in the arches, are therefore different, so that here we have a point marking the greatest distance in this quarter, to which the mechanical discoveries of Galileo extended. The first person who investigated the exact time of a vibration in an arch of a circle was Huygens, a very profound mathematician.

To this list of mechanical discoveries, already so important and extensive, we must add, that Galileo was the first who maintained the existence of the *law of continuity*, and who made use of it as a principle in his reasonings on the phenomena of motion.¹

The vibrations of the pendulum having suggested to Galileo the means of measuring time accurately, it appears certain that the idea of applying it to the clock had also occurred to him, and of using the chronometer so formed for finding the longitude, by means of observations made on the eclipses of the satellites of Jupiter. How far he had actually proceeded in an invention which required great practical knowledge, and which afterwards did so much credit to Huygens, appears to be uncertain, and not now easy to be ascertained. But that the project had occurred to him, and that he had taken some steps towards realizing it, is sufficiently established.

One forms, however, a very imperfect idea of this philosopher, from considering the discoveries and inventions, numerous and splendid as they are, of which he was the undisputed author. It is by following his reasonings, and by pursuing the train of his thoughts in his own elegant, though somewhat diffuse exposition of them, that we become acquainted with the fertility of his genius, with the sagacity, penetration, and comprehensiveness of his mind. The service which he rendered to real knowledge, is to be estimated not only from the truths which he discovered, but from the errors which he detected,—not merely from the sound principles which he established, but from the pernicious idols which he overthrew. His acuteness was strongly displayed in the address with which he exposed the errors of his adversaries, and refuted their opinions, by comparing one part of them with another, and proving their extreme inconsistency. Of all the writers who have lived in an age, which was yet only emerging from ignorance and barbarism, Galileo has most entirely the tone of true philosophy, and is most free from any contamination of the times in taste, sentiment, and opinion.

¹ Opere de Galileo, Tom. IV. Dial. 1. p. 32, Florence edition, and in many other parts.

The discoveries of this great man concerning motion drew the attention of philosophers more readily, from the circumstance that the astronomical theories of Copernicus had directed their attention to the same subject. It had become evident, that the great point in dispute between his system and the Ptolemaic must be finally decided by an appeal to the nature of motion and its laws. The great argument to which the friends of the latter system naturally had recourse was the impossibility, as it seemed to them to be, of the swift motion of the earth being able to exist, without the perception, nay, even without the destruction, of its inhabitants. It was natural for the followers of Copernicus to reply, that it was not certain that these two things were incompatible; that there were many cases in which it appeared, that the motion common to a whole system of bodies did not affect the motion of those bodies relatively to one another; that the question must be more deeply inquired into; and that, without this, the evidence on opposite sides could not be fairly and accurately compared. Thus it was, at a very fortunate moment, that Galileo made his discoveries in Mechanics, as they were rendered more interesting by those which, at that very time, he himself was making in Astronomy. The system of Copernicus had, in this manner, an influence on the theory of motion, and, of course, on all the parts of natural philosophy. The *inertia* of matter, or, the tendency of body, when put in motion, to preserve the quantity and direction of that motion, after the cause which impressed it has ceased to act, is a principle which might still have been unknown, if it had not been forced upon us by the discovery of the motion of the earth.

The first addition which was made to the mechanical discoveries of Galileo was by Torricelli, in a treatise *De Motu Graviorum naturaliter descendantium et projectorum.*¹ To this ingenious man we are indebted for the discovery of a remarkable property of the centre of gravity, and a general principle with respect to the equilibrium of bodies. It is this: If there be any number of heavy bodies connected together, and so circumstanced, that by their motion their centre of gravity can neither ascend nor descend, these bodies will remain at rest. This proposition often furnishes the means of resolving very difficult questions in mechanics.

Descartes, whose name is so great in philosophy and mathematics, has also a place in the history of mechanical discovery. With regard to the action of machines, he laid down the same principle which Galileo had established,—that an equal effort is neces-

¹ Vitæ Italarum Illustrium, Vol. I. p. 347.

sary to give to a weight a certain velocity, as to give to double the weight the half of that velocity, and so on in proportion, the effect being always measured by the weight multiplied into the velocity which it receives. He could hardly be ignorant that this proposition had been already stated by Galileo, but he has made no mention of it. He, indeed, always affected a disrespect for the reasonings and opinions of the Italian philosopher, which has done him no credit in the eyes of posterity.

The theory of motion, however, has in some points been considerably indebted to Descartes. Though the reasonings of Galileo certainly involve the knowledge of the disposition which matter has to preserve its condition either of rest or of rectilinear and uniform motion, the first distinct enunciation of this law is found in the writings of the French philosopher. It is, however, there represented, not as mere inactivity, or indifference, but as a real force, which bodies exert in order to preserve their state of rest or of motion, and this inaccuracy affects some of the reasonings concerning their action on one another.

Descartes, however, argued very justly, that all motion being naturally rectilinear, when a body moves in a curve, this must arise from some constraint, or some force urging it in a direction different from that of the first impulse, and that if this cause were removed at any time, the motion would become rectilinear, and would be in the direction of a tangent, to the curve at the point where the deflecting force ceased to act.

Lastly, He taught that the quantity of motion in the universe remains always the same.

The reasoning by which he supported the first and second of these propositions is not very convincing, and though he might have appealed to experience for the truth of both, it was not in the spirit of his philosophy to take that method of demonstrating its principles. His argument was, that motion is a state of body, and that body or matter cannot change its own state. This was his demonstration of the first proposition, from which the second followed necessarily.

The evidence produced for the third, or the preservation of the same quantity of motion in the universe, is founded on the immutability of the Divine nature, and is an instance of the intolerable presumption which so often distinguished the reasonings of this philosopher. Though the immutability of the Divine nature will readily be admitted, it remains to be shown, that the continuance of the same quantity of motion in the universe is a consequence of it. This, indeed, cannot be shown, for that quantity, in the sense in which Descartes understood it, is so far from being preserved uniform, that it varies continually from one instant to another. It is nevertheless true, that the

quantity of motion in the universe, when rightly estimated, is invariable, that is, when reduced to the direction of three axes at right angles to one another, and when opposite motions are supposed to have opposite signs. This is a truth now perfectly understood, and is a corollary to the equality of action and reaction, in consequence of which, whatever motion is communicated in one direction, is either lost in that direction, or generated in the opposite. This, however, is quite different from the proposition of Descartes, and if expressed in his language, would assert, not that the sum, but that the difference of the opposite motions in the universe remains constantly the same. When he proceeds, by help of the principle which he had thus mistaken, to determine the laws of the collision of bodies, his conclusions are almost all false, and have, indeed, such a want of consistency and analogy with one another, as ought, in the eyes of a mathematician, to have appeared the most decisive indications of error. How this escaped the penetration of a man well acquainted with the harmony of geometrical truths, and the gradual transitions by which they always pass into one another, is not easily explained, and perhaps, of all his errors, is the least consistent with the powerful and systematic genius which he is so well known to have possessed.

Thus, the obligation which the theory of motion has to this philosopher, consists in his having pointed out the nature of centrifugal force, and ascribed that force to the true cause, the inertia of body, or its tendency to uniform and rectilinear motion.

The laws which actually regulate the collision of bodies remained unknown till some years later, when they were recommended by the Royal Society of London to the particular attention of its members. Three papers soon appeared, in which these laws were all correctly laid down, though no one of the authors had any knowledge of the conclusions obtained by the other two. The first of these was read to the Society, in November 1668, by Dr Wallis of Oxford; the next by Sir Christopher Wren in the month following, and the third by Huygens in January 1669. The equality of action and reaction, and the maxim, that the same force communicates to different bodies velocities which are inversely as their masses, are the principles on which these investigations are founded.

The ingenious and profound mathematician last mentioned is also the first who explained the true relation between the length of a pendulum, and the time of its least vibrations, and gave a rule by which the time of the rectilinear descent, through a line equal in length to the pendulum, might from thence be deduced. He next applied the pendulum to regulate the motion of a clock, and gave an account of his construction, and the principles of it, in his *Horologium Oscillatorium*, about the year 1670, though the date of the inven-

tion goes as far back as 1656.¹ Lastly, He taught how to correct the imperfection of a pendulum, by making it vibrate between cycloidal cheeks, in consequence of which its vibrations, whether great or small, became, not approximately, but precisely of equal duration.

Robert Hooke, a very celebrated English mechanician, laid claim to the same application of the pendulum to the clock, and the same use of the cycloidal cheeks. There is, however, no dispute as to the priority of Huygens' claim, the invention of Hooke being as late as 1670. Of the cycloidal cheeks, he is not likely to have been even the second inventor. Experiment could hardly lead any one to this discovery, and he was not sufficiently skilled in the mathematics to have found it out by mere reasoning. The fact is, that though very original and inventive, Hooke was jealous and illiberal in the extreme; he appropriated to himself the inventions of all the world, and accused all the world of appropriating his.

It has already been observed, that Galileo conceived the application of the pendulum to the clock earlier, by several years, than either of the periods just referred to. The invention did great honour to him and to his two rivals; but that which argues the most profound thinker, and the most skilful mathematician of the three, is the discovery of the relation between the length of the pendulum and the time of its vibration, and this discovery belongs exclusively to Huygens. The method which he followed in his investigation, availing himself of the properties of the cycloid, though it be circuitous, is ingenious, and highly instructive.

An invention, in which Hooke has certainly the priority to any one, is the application of a spiral spring to regulate the balance of a watch. It is well known of what practical utility this invention has been found, and how much it has contributed to the solution of the problem of finding the longitude at sea, to which not only he, but Galileo and Huygens, appear all to have had an eye.

In what respects the theory of motion, Huygens has still another strong claim to our notice. This arises from his solution of the problem of finding the centre of oscillation of a compound pendulum, or the length of the simple pendulum vibrating in the same time with it. Without the solution of this problem, the conclusions respecting the pendulum were inapplicable to the construction of clocks, in which the pendulums used are of necessity compound. The problem was by no means easy, and Huygens was obliged to intro-

¹ Montucla, Tom. II. p. 418, 2d edit.

duce a principle which had not before been recognised, that if the compound pendulum, after descending to its lowest point, was to be separated into particles distinct and unconnected with one another, and each left at liberty to continue its own vibration, the common centre of gravity of all those detached weights would ascend to the same height to which it would have ascended had they continued to constitute one body. The above principle led him to the true solution, and his investigation, though less satisfactory than those which have been since given, does great credit to his ingenuity. This was the most difficult mechanical inquiry which preceded the invention of the differential or fluxionary calculus.

2. HYDROSTATICS.

While the theory of motion, as applied to solids, was thus extended, in what related to fluids, it was making equal progress. The laws which determine the weight of bodies immersed in fluids, and also the position of bodies floating on them, had been discovered by Archimedes, and were farther illustrated by Galileo. It had also been discovered by Stevinus, that the pressure of fluids is in proportion to their depth, and thus the two leading principles of hydrostatics were established. Hydraulics, or the motion of fluids, was a matter of more difficulty, and here the first step is to be ascribed to Torricelli, who, though younger than Galileo, was for some time his contemporary. He proved that water issues from a hole in the side or bottom of a vessel, with the velocity which a body would acquire, by falling from the level of the surface to the level of the orifice. This proposition, now so well known as the basis of the whole doctrine of Hydraulics, was first published by Torricelli at the end of his book, *De Motu Gravium et Projectorum*; but it is not the greatest discovery which science owes to the friend and disciple of Galileo. The latter had failed in assigning the reason why water cannot be raised in pumps higher than thirty-three feet, but he had remarked, that if a pump is more than thirty-three feet in length, a vacuum will be left in it. Torricelli, reflecting on this, conceived, that if a heavier fluid than water were used, a vacuum might be produced, in a way far shorter, and more compendious. He tried mercury, therefore, and made use of a glass tube about three feet long, open at one end, and close at the other, where it terminated in a globe. He filled this tube, shut it with his finger, and inverted it in a basin of mercury. The result is well known;—he found that a column of mercury was suspended in the tube, an effect which he immediately ascribed to the pressure of the atmosphere. So disinterested was this philosopher, however, that he is said to have lamented that Galileo, when inquiring into the cause why water does not ascend in pumps above a certain height, had not discovered

the true cause of the phenomenon. The generosity of Torricelli was perhaps rarer than his genius;—there are more who might have discovered the suspension of mercury in the barometer, than who would have been willing to part with the honour of the discovery to a master or a friend.

This experiment opened the door to a multitude of new discoveries, and demolished a formidable idol, the horror of a vacuum, to which so much power had been long attributed, and before which even Galileo himself had condescended to bow.

The objections which were made to the explanation of the suspension of the mercury in the tube of the barometer, were overthrown by carrying that instrument to the top of Puy de Dome, an experiment suggested by Pascal. The descent of the mercury showed, that the pressure which supported it was less there than at the bottom; and it was afterwards found, that the fall of the mercury corresponded exactly to the diminution of the length of the pressing column, so that it afforded a measure of that diminution, and, consequently, of the heights of mountains. The invention of the air-pump by Otto Guericke, burgomaster of Magdeburg, quickly followed that of the barometer by Torricelli, though it does not appear that the invention of the Italian philosopher was known to the German. In order to obtain a space entirely void of air, Otto Guericke filled a barrel with water, and having closed it exactly on all sides, began to draw out the water by a sucking-pump applied to the lower part of the vessel. He had proceeded but a very little way, when the air burst into the barrel with a loud noise, and its weight was proved by the failure of the experiment, as effectually as it could have been by its success. After some other trials, which also failed, he thought of employing a sphere of glass, when the experiment succeeded, and a vacuum was obtained. This was about the year 1654.

The elasticity of the air, as well as its weight, now became known; its necessity to combustion, and the absorption of a certain proportion of it, during that process; its necessity for conveying sound;—all these things were clearly demonstrated. The necessity of air to the respiration of animals required no proof from experiment, but the sudden extinction of life, by immersion in a vacuum, was a new illustration of the fact.

The first considerable improvements made on the air-pump are due to Mr Boyle. He substituted to the glass globe of Otto Guericke a receiver of a more commodious form, and constructed his pump so as to be worked with much more facility. His experiments were farther extended,—they placed the weight and elasticity of the air in a variety of new lights,—they made known the power of air to dissolve water, &c. Boyle had great skill in contriving, and great dexterity in performing experiments. He had, in-

deed, very early applied himself to the prosecution of experimental science, and was one of the members of the small but distinguished body, who, during the civil wars, held private meetings for cultivating natural knowledge, on the plan of Bacon. They met first in London, as early as 1645, afterwards at Oxford, taking the name of the *Philosophic College*. Of them, when Charles the Second ascended the throne, was formed the Royal Society of London, incorporated by letters patent in 1662. No one was more useful than Boyle in communicating activity and vigour to the new institution. A real lover of knowledge, he was most zealous in the pursuit of it; and having thoroughly imbibed the spirit of Bacon, was an avowed enemy to the philosophy of Aristotle.

SECTION IV.

ASTRONOMY.

1. ANCIENT ASTRONOMY.

It has already been remarked, that the ancients made more considerable advances in astronomy than in almost any other of the physical sciences. They applied themselves diligently to observe the heavens, and employed mathematical reasoning to connect together the insulated facts, which are the only objects of direct observation. The astronomer discovers nothing by help of his instruments, but that, at a given instant, a certain luminous point has a particular position in the heavens. The application of mathematics, and particularly of spherical trigonometry, enables him to trace out the precise tract of this luminous spot; to discover the rate of its motion, whether varied or uniform, and thus to resolve the first great problem which the science of astronomy involves, viz. to express the positions of the heavenly bodies, relatively to a given plane in functions of the time. The problem thus generally enunciated, comprehends all that is usually called by the name of descriptive or mathematical astronomy.

The explanation of the celestial motions, which naturally occurred to those who began the study of the heavens, was, that the stars are so many luminous points fixed in the surface of a sphere, having the earth in its centre, and revolving on an axis passing through that centre in the space of twenty-four hours. When it was observed that all the stars did not partake of this diurnal motion in the same degree, but that some were carried slowly towards the east, and that their paths estimated in that direction, after certain in-

tervals of time, returned into themselves, it was believed that they were fixed in the surfaces of spheres, which revolved westward, more slowly than the sphere of the fixed stars. These spheres must be transparent, or made of some crystalline substance, and hence the name of the crystalline spheres, by which they were distinguished. This system, though it grew more complicated in proportion to the number and variety of the phenomena observed, was the system of Aristotle and Eudoxus, and, with a few exceptions, of all the philosophers of antiquity.

But when the business of observation came to be regularly pursued; when Timocharis and Aristillus, and their successors in the Alexandrian school, began to study the phenomena of the heavens, little was said of these orbs; and astronomers seemed only desirous of ascertaining the laws or the general facts concerning the planetary motions.

To do this, however, without the introduction of hypothesis, was certainly difficult, and probably was then impossible. The simplest and most natural hypothesis was, that the planets moved eastward in circles, and at a uniform rate. But when it was found that, instead of moving uniformly to the eastward, every one of them was subject to great irregularity, the motion eastward becoming at certain periods slower, and at length vanishing altogether, so that the planet became stationary, and afterwards acquiring a motion in the contrary direction, proceeded for a time toward the west, it was far from obvious how all these appearances could be reconciled with the idea of a uniform circular motion.

The solution of this difficulty is ascribed to Apollonius Pergæus, one of the greatest geometers of antiquity. He conceived that, in the circumference of a circle, having the earth for its centre, there moved the centre of another circle, in the circumference of which the planet actually revolved. The first of these circles was called the *deferent*, and the second the *epicycle*, and the motion in the circumference of each was supposed uniform. Lastly, it was conceived that the motion of the centre of the epicycle in the circumference of the deferent, and of the planet in that of the epicycle, were in opposite directions, the first being towards the east, and the second towards the west. In this way, the alterations from progressive to retrograde, with the intermediate stationary points, were readily explained, and Apollonius carried his investigation so far as to determine the ratio between the radius of the deferent, and that of epicycle, from knowing the stations and retrogradations of any particular planet.

An object, which was then considered as of great importance to astronomy, was thus accomplished, viz. the production of a variable motion, or one which was continually changing both its rate and its direction from two uniform circular motions, each of which preserved always the same quantity and the same direction.

It was not long before another application was made of the method of epicycles. Hipparchus, the greatest astronomer of antiquity, and one of the inventors in science most justly entitled to admiration, discovered the inequality of the sun's apparent motion round the earth. To explain or to express this irregularity, the same observer imagined an epicycle of a small radius with its centre moving uniformly in the circumference of a large circle, of which the earth was the centre, while the sun revolved in the circumference of the small circle with the same angular velocity as this last, but in a contrary direction.

As other irregularities in the motions of the moon and of the planets were observed, other epicycles were introduced, and Ptolemy, in his *Almagest*, enumerated all which then appeared necessary, and assigned to them such dimensions as enabled them to express the phenomena with accuracy. It is not to be denied that the system of the heavens became in this way extremely complicated; though, when fairly examined, it will appear to be a work of great ingenuity and research. The ancients, indeed, may be regarded as very fortunate in the contrivance of epicycles, because, by means of them, every inequality which can exist in the angular motion of a planet may be at least nearly represented. This I call fortunate, because, at the time when Apollonius introduced the epicycle, he had no idea of the extent to which his contrivance would go, as he could have none of the conclusions which the author of the *Mécanique Céleste* was to deduce from the principle of gravitation.

The same contrivance had another great advantage; it subjected the motions of the sun, the moon, and the planets, very readily to a geometrical construction, or an arithmetical calculation, neither of them difficult. By this means the predictions of astronomical phenomena, the calculation of tables, and the comparison of those tables with observation, became matters of great facility, on which facility, in a great measure, the progress of the science depended. It was on these circumstances, much more than on the simplicity with which it amused or deceived the imagination, that the popularity of this theory was founded; the ascendant which it gained over the minds of astronomers, and the resistance which, in spite of facts and observations, it was so long able to make to the true system of the world.

It does not appear that the ancient astronomers ever considered the epicycles and deferents which they employed in their system as having a physical existence, or as serving to *explain* the causes of the celestial motions. They seem to have considered them merely as mathematical diagrams, serving to *express* or to represent those motions as geometrical expressions of certain general facts, which readily furnished the rules of astronomical calculation.

The language in which Ptolemy speaks of the epicycles is not a little curious, and very conformable to the notion, that he considered them as merely the means of expressing a general law. After laying down the hypothesis of certain epicycles, and their dimensions, it is usual with him to add, "these suppositions will *save* the phenomena." *Save* is the literal translation of the Greek word, which is always a part of the verb $\Sigma\omega\zeta\epsilon\iota\tau$, or some of its compounds. Thus, in treating of certain phenomena in the moon's motion, he lays down two hypotheses, by either of which they may be expressed; and he concludes, "in this way the similitude of the ratios, and the proportionality of the times, will be *saved* ($\delta\iota\alpha\sigma\omega\zeta\omicron\upsilon\tau\omicron$) on both suppositions."¹ It is plain, from these words, that the astronomer did not here consider himself as describing any thing which actually existed, but as explaining two artifices, by either of which, certain irregularities in the moon's motion may be represented, in consistence with the principle of uniform velocity. The hypothesis does not relate to the explanation, but merely to the expression of the fact; it is first assumed, and its merit is then judged of synthetically, by its power to *save*, to reconcile, or to represent appearances. At a time when the mathematical sciences extended little beyond the elements, and when problems which could not be resolved by circles and straight lines, could hardly be resolved at all, such artifices as the preceding were of the greatest value. They were even more valuable than the truth itself would have been in such circumstances; and nothing is more certain than that the real elliptical orbits of the planets, and the uniform description of areas, would have been very unseasonable discoveries at the period we are now treating of. The hypotheses of epicycles, and of centres of uniform motion,

¹ Mathematica Syntaxis, Lib. IV. p. 223 of the Paris edition.—Milton, the extent and accuracy of whose erudition can never be too much admired, had probably in view this phraseology of Ptolemy, when he wrote the following lines:—

———" He his fabric of the Heavens
Hath left to their disputes, perhaps to move
His laughter at their quaint opinions wide
Hereafter, when they come to model Heaven
And calculate the stars, how they will wield
The mighty frame, how build, unbuild, contrive
To *save appearances*, how gird the sphere
With centrick and eccentric scribbled o'er,
Cycle and epicycle, orb in orb."

The obsolete verb *to save* is employed by Bacon, and many other of the old English writers in the same sense with $\Sigma\omega\zeta\epsilon\iota\tau$ in the work of Ptolemy here referred to. "The schoolmen were like the astronomers, who, to *save* phenomena, framed to their conceit eccentricks and epicycles; so they, to *save* the practice of the church, had devised a great number of strange positions." Bacon.

were well accommodated to the state of science, and are instances of a false system which has materially contributed to the establishment of truth.

2. COPERNICUS AND TYCHO.

On the revival of learning in Europe, astronomy was the first of the sciences which was regenerated. Such, indeed, is the beauty and usefulness of this branch of knowledge, that, in the thickest darkness of the middle ages, the study of it was never entirely abandoned. In those times of ignorance, it also derived additional credit from the assistance which it seemed to give to an imaginary and illusive science. Astrology, which has exercised so durable and extensive a dominion over the human mind, is coëval with the first observations of astronomy. In the middle ages, remarkable for the mixture of a few fragments of knowledge and truth in a vast mass of ignorance and error, it was assiduously cultivated, and, in conjunction with alchemy and magic, shared the favour of the people, and the patronage of the great. During the thirteenth and fourteenth centuries, it was taught in the universities of Italy, and professors were appointed, at Padua and Bologna, to instruct their pupils in the influence of the stars. Everywhere through Europe the greatest respect was shown for this system of imposture, and they who saw the deceit most clearly, could not always avoid the disgrace of being the instruments of it. Astronomy, however, profited by the illusion, and was protected for the great assistance which it seemed to afford to a science more important than itself.

Of those who cultivated astronomy, many were infected by this weakness, though some were completely superior to it. Alphonso, the King of Castile, was among the latter. He flourished about the middle of the thirteenth century, and was remarkable for such freedom of thought, and such boldness of language, as it required his royal dignity to protect. He applied himself diligently to the study of astronomy; he perceived the inaccuracy of Ptolemy's tables, and endeavoured to correct their errors by new tables of his own. These, in the course of the next age, were found to have receded from the heavens, and it became more and more evident that astronomers had not yet discovered the secret of the celestial motions.

Two of the men who, in the fifteenth century, contributed the most to the advancement of astronomical science, Purbach and Regiomontanus, were distinguished also for their general knowledge of the mathematics. Purbach was fixed at Vienna by the patronage of the Emperor Frederick the Third, and devoted himself to astronomical observation. He published a new edition of the *Almagest*, and, though he neither under-

stood Greek nor Arabic, his knowledge of the subject enabled him to make it much more perfect than any of the former translations. He is said to have been the first who applied the plummet to astronomical instruments; but this must not be understood strictly, for some of Ptolemy's instruments, the parallactic for instance, were placed perpendicularly by the plumb-line.

Regiomontanus was the disciple of Purbach, and is still more celebrated than his master. He was a man of great learning and genius, most ardent for the advancement of knowledge, and particularly devoted to astronomy. To him we owe the introduction of decimal fractions, which completed our arithmetical notation, and formed the second of the three steps by which, in modern times, the science of numbers has been so greatly improved.

In the list of distinguished astronomers, the name of Copernicus comes next, and stands at the head of those men, who, bursting the fetters of prejudice and authority, have established truth on the basis of experience and observation. He was born at Thorn in Prussia, in 1473; he studied at the university of Cracow, being intended at first for a physician, though he afterwards entered into the church. A decided taste for astronomy led him early to the study of the science in which he was destined to make such an entire revolution, and as soon as he found himself fixed and independent, he became a diligent and careful observer.

It would be in the highest degree interesting to know by what steps he was led to conceive the bold system which removes the earth from the centre of the world, and ascribes to it a twofold motion. It is probable that the complication of so many epicycles and deferents as were necessary, merely to express the laws of the planetary motions, had induced him to think of all the possible suppositions which could be employed for the same purpose, in order to discover which of them was the simplest.

It appears extraordinary, that so natural a thought should have occurred, at so late a period, for the first, or nearly for the first time. We are assured, by Copernicus himself, that one of the first considerations which offered itself to his mind, was the effect produced by the motion of a spectator, in transferring that motion to the objects observed, but ascribing to it an opposite direction.¹ From this principle it immediately followed, that the rotation of the earth on an axis, from west to east, would produce the apparent motion of the heavens in the direction from east to west.

¹ *Astronomia Instaurata*, Lib. I. cap. 5.

In considering some of the objections which might be made to the system of the earth's motion, Copernicus reasons with great soundness, though he is not aware of the full force of his own argument. Ptolemy had alleged, that, if the earth were to revolve on its axis, the violence of the motion would be sufficient to tear it in pieces, and to dissipate the parts. This argument, it is evident, proceeds on a confused notion of a centrifugal force, the effect of which the Egyptian astronomer overrated, as much as he undervalued the firmness and solidity of the earth. Why, says Copernicus, was he not more alarmed for the safety of the heavens, if the diurnal revolution be ascribed to them, as their motion must be more rapid, in proportion as their magnitude is greater? The argument here suggested, now that we know how to measure centrifugal force, and to compare it with others, carries demonstrative evidence with it, because that force, if the diurnal revolution were really performed by the heavens, would be such, as the forces which hold together the frame of the material world would be wholly unable to resist.

There are, however, in the reasonings of Copernicus, some unsound parts, which show, that the power of his genius was not able to dispel all the clouds which in that age hung over the human mind, and that the unfounded distinctions of the Aristotelian physics sometimes afforded arguments equally fallacious to him and to his adversaries. One of his most remarkable physical mistakes was his misconception with respect to the parallelism of the earth's axis; to account for which, he thought it necessary to assume, in addition to the earth's rotation on an axis, and revolution round the sun, the existence of a third motion altogether distinct from either of the others. In this he was mistaken; the axis naturally retains its parallelism, and it would require the action of a force to make it do otherwise. This, as Kepler afterwards remarked, is a consequence of the *inertia* of matter; and, for that reason, he very justly accused Copernicus of not being fully acquainted with his own riches.

The first edition of the *Astronomia Instaurata*, the publication of which was solicited by Cardinal Schoenberg, and the book itself dedicated to the Pope, appeared in 1543, a few days before the death of the author. Throughout the whole book, the new doctrine was advanced with great caution, as if from a presentiment of the opposition and injustice which it was one day to experience. At first, however, the system attracted little notice, and was rejected by the greater part even of astronomers. It lay fermenting in secret with other new discoveries for more than fifty years, till, by the exertions of Galileo, it was kindled into so bright a flame as to consume the philosophy of Aristotle, to alarm the hierarchy of Rome, and to threaten the existence of every opinion not founded on experience and observation.

After Copernicus, Tycho Brahe was the most distinguished astronomer of the six-

teenth century. An eclipse of the sun which he witnessed in 1560, when he was yet a very young man, by the exactness with which it answered to the prediction, impressed him with the greatest reverence for a science which could see so far and so distinctly into the future, and from that moment he was seized with the strongest desire of becoming acquainted with it. Here, indeed, was called into action a propensity nearly allied both to the strength and the weakness of the mind of this extraordinary man, the same that attached him, on one hand, to the calculations of astronomy, and, on the other, to the predictions of judicial astrology.

In yielding himself up, however, to his love of astronomy, he found that he had several difficulties to overcome. He belonged to a class in society elevated, in the opinion of that age, above the pursuit of knowledge, and jealous of the privilege of remaining ignorant with impunity. Tycho was of a noble family in Denmark, so that it required all the enthusiasm and firmness inspired by the love of knowledge, to set him above the prejudices of hereditary rank, and the opposition of his relations. He succeeded, however, in these objects, and also in obtaining the patronage of the King of Denmark, by which he was enabled to erect an observatory, and form an establishment in the island of Huena, such as had never yet been dedicated to astronomy. The instruments were of far greater size, more skilfully contrived, and more nicely divided, than any that had yet been directed to the heavens. By means of them, Tycho could measure angles to ten seconds, which may be accounted sixty times the accuracy of the instruments of Ptolemy, or of any that had belonged to the school of Alexandria.

Among the improvements which he made in the art of astronomical observation, was that of verifying the instruments, or determining their errors by actual observation, instead of trusting, as had been hitherto done, to the supposed infallibility of the original construction.

One of the first objects to which the Danish astronomer applied himself was the formation of a new catalogue of the fixed stars. That which was begun by Hipparchus, and continued by Ptolemy, did not give the places of the stars with an accuracy nearly equal to that which the new instruments were capable of reaching; and it was besides desirable to know whether the lapse of twelve centuries had produced any unforeseen changes in the heavens.

The great difficulty in the execution of this work arose from the want of a direct and easy method of ascertaining the distance of one heavenly body due east or west of another. The distance north or south, either from one another or from a fixed plane, that of the equator, was easily determined by the common method of meridian altitudes, the

equator being a plane which, for any given place on the earth's surface, retains always the same position. But no plane extending from north to south, or passing through the poles, retains a fixed position with respect to an observer, and, therefore, the same way of measuring distances from such a plane cannot be applied. The natural substitute is the measure of time; the interval between the passage of two stars over the meridian, bearing the same proportion to twenty-four hours, that the arch which measures their distance perpendicular to the meridian, or their difference of right ascension, does to four right angles.

An accurate measure of time, therefore, would answer the purpose, but such a measure no more existed in the age of Tycho, than it had done in the days of Hipparchus or Ptolemy. These ancient astronomers determined the longitude of the fixed stars by referring their places to those of the moon, the longitude of which, for a given time, was known from the theory of her motions. Thus they were forced to depend on the most irregular of all the bodies in the heavens, for ascertaining the positions of the most fixed, those which ought to have been the basis of the former, and of so many other determinations. Tycho made use of the planet Venus instead of the moon, and his method, though more tedious, was more accurate than that of the Greek astronomers. His catalogue contained the places of 777 fixed stars.

The irregularities of the moon's motions were his next subjects of inquiry. The ancients had discovered the inequality of that planet depending on the eccentricity of the orbit, the same which is now called the equation of the centre.¹ Ptolemy had added the knowledge of another inequality in the moon's motion, to which the name of the evection has been given, amounting to an increase of the former equation at the quarters, and a diminution of it at the times of new and full moon. Tycho discovered another inequality, which is greatest at the octants, and depends on the difference between the longitude of the moon and that of the sun. A fourth irregularity to which the moon's motion is subject, depending wholly on the sun's place, was known to Tycho, but included among the sun's equations. Besides, these observations made him acquainted with the changes in the inclination of the plane of the moon's orbit; and, lastly, with the irregular motion of the nodes, which, instead of being always retrograde at the same rate, are subject to change that rate, and even to become progressive according to their situation in

¹ The allowance made for any such equality, when the place of a planet is to be computed for a given time, is called an *equation* in the language of astronomy.

respect of the sun. These are the only inequalities of the moon's motion known before the theory of Gravitation, and, except the two first, are all the discoveries of Tycho.

The atmospherical refraction, by which the heavenly bodies are made to appear more elevated above the horizon than they really are, was suspected before the time of this astronomer, but not known with certainty to exist. He first became acquainted with it by finding that the latitude of his observatory, as determined from observations at the solstices, and from observations of the greatest and least altitudes of the circumpolar stars, always differed about four minutes. The effect of refraction he supposed to be $84'$ at the horizon, and to diminish from thence upward, till at 45° it ceased altogether. This last supposition is erroneous, but at 45° the refraction is less than $1'$, and probably was not sensible in the altitudes measured with his instruments, or not distinguishable from the errors of observation. An instrument which he contrived on purpose to make the refraction distinctly visible, shows the scale on which his observatory was furnished. It was an equatorial circle of ten feet diameter, turning on an axis parallel to that of the earth. With the sights of this equatorial he followed the sun on the day of the summer solstice, and found, that, as it descended towards the horizon, it rose above the plane of the instrument. At its setting, the sun was raised above the horizon by more than its own diameter.

The comet of 1570 was carefully observed by Tycho, and gave rise to a new theory of these bodies. He found the horizontal parallax to be $20'$, so that the comet was nearly three times as far off as the moon. He considered comets, therefore, as bodies placed far beyond the reach of our atmosphere, and moving round the sun. This was a severe blow to the physics of Aristotle, which regarded comets as meteors generated in the atmosphere. His observation of the new star in 1572, was no less hostile to the argument of the same philosopher, which maintained, that the heavens are a region in which there is neither generation nor corruption, and in which existence has neither a beginning nor an end.

Yet Tycho, with this knowledge of astronomy, and after having made observations more numerous and accurate than all the astronomers who went before him, continued to reject the system of Copernicus, and to deny the motion of the earth. He was, however, convinced that the earth is not the centre about which the planets revolve, for he had himself observed Mars, when in opposition, to be nearer to the earth than the earth was to the sun, so that, if the planets were ranged as in the Ptolemaic system, the orbit of Mars must have been within the orbit of the sun. He therefore imagined the system still known by his name, according to which the sun moves round the earth, and is at the same time

the centre of the planetary motions. It cannot be denied, that the phenomena purely astronomical may be accounted for on this hypothesis, and that the objections to it are rather derived from physical and mechanical considerations than from the appearances themselves. It is simpler than the Ptolemaic system, and free from its inconsistencies; but it is more complex than the Copernican, and, in no respect, affords a better explanation of the phenomena. The true place of the Tyconic system is between the two former; an advance beyond the one, and a step short of the other; and such, if the progress of discovery were always perfectly regular, is the place which it would have occupied in the history of the science. If Tycho had lived before Copernicus, his system would have been a step in the advancement of knowledge; coming after him, it was a step backward.

It is not to his credit as a philosopher to have made this retrograde movement, yet he is not altogether without apology. The physical arguments in favour of the Copernican system, founded on the incongruity of supposing the greater body to move round the smaller, might not be supposed to have much weight, in an age when the equality of action and reaction was unknown, and when it was not clearly understood that the sun and the planets act at all on one another. The arguments, which seem, in the judgment of Tycho, to have balanced the simplicity of the Copernican system, were founded on certain texts of Scripture, and on the difficulty of reconciling the motion of the earth with the sensations which we experience at its surface, or the phenomena which we observe, the same, in all respects, as if the earth were at rest. The experiments and reasonings of Galileo had not yet instructed men in the *inertia* of matter, or in the composition of motion; and the followers of Copernicus reasoned on principles which they held in common with their adversaries. A ball, it was said by the latter, dropt from the mast-head of a ship under sail, does not fall at the foot of the mast, but somewhat behind it; and, in the same manner, a stone dropt from a high tower would not fall, on the supposition of the earth's motion, at the bottom of the tower, but to the west of it, the earth, during its fall, having gone eastward from under it. The followers of Copernicus were not yet provided with the true answer to this objection, viz. that the ball does actually fall at the bottom of the mast. It was admitted that it must fall behind it, because the ball was no part of the ship, and that the motion forward was not natural, either to the ship or to the ball. The stone, on the other hand, let fall from the top of the tower, was a part of the earth; and, therefore, the diurnal and annual revolutions which were natural to the earth, were also natural to the stone; the stone would, therefore, retain the same motion with the tower, and strike the ground precisely at the bottom of it.

It must be confessed, that neither of these logicians had yet thoroughly awakened from the dreams of the Aristotelian metaphysics, but men were now in possession of the truth, which was finally to break the spell, and set the mind free from the fetters of prejudice and authority. Another charge, against which it is more difficult to defend Tycho, is his belief in the predictions of astrology. He even wrote a treatise in defence of this imaginary art, and regulated his conduct continually by its precepts. Credulity, so unworthy of a man deeply versed in real science, is certainly to be set down less to his own account than to that of the age in which he lived.

3. KEPLER AND GALILEO.

Kepler followed Tycho, and in his hands astronomy underwent a change only second to that which it had undergone in the hands of Copernicus. He was born in 1571. He early applied himself to study and observe the heavens, and was soon distinguished as an inventor. He began with taking a more accurate view of astronomical refraction than had yet been done, and he appears to have been the first who conceived that there must be a certain fixed law which determined the quantity of it, corresponding to every altitude, from the horizon to the zenith. The application of the principles of optics to astronomy, and the accurate distinction between the optical and real inequalities of the planets, are the work of the same astronomer. It was by the views thus presented that he was led to the method of constructing and calculating eclipses, by means of projections, without taking into consideration the diurnal parallax. These are valuable improvements, but they were, however, obscured by the greatness of his future discoveries.

The planes of the orbits of the planets were naturally, in the Ptolemaic system, supposed to pass through the earth, and the reformation of Copernicus did not go so far as to change the notions on that subject which had generally been adopted. Kepler observed that the orbits of the planets are in planes passing through the sun, and that, of consequence, the lines of their nodes all intersect in the centre of that luminary. This discovery contributed essentially to those which followed.

The oppositions of the planets, or their places when they pass the meridian at midnight, offer the most favourable opportunities for observing them, both because they are at that time nearest to the earth, and because their places seen from thence is the same as if they were seen from the sun. The true time of the opposition had, however, been till now mistaken by astronomers, who held it to be at the moment when the apparent place of the planet was opposite to the mean place of the sun. It ought, however,

to have been, when the apparent places of both were opposed to one another. This reformation was proposed by Kepler, and, though strenuously resisted by Tycho, was finally received.

Having undertaken to examine the orbit of Mars, in which the irregularities are most considerable, Kepler discovered, by comparing together seven oppositions of that planet, that its orbit is elliptical; that the sun is placed in one of the foci; and that there is no point round which the angular motion is uniform. In the pursuit of this inquiry he found that the same thing is true of the earth's orbit round the sun; hence by analogy it was reasonable to think, that all the planetary orbits are elliptical, having the sun in their common focus.

The industry and patience of Kepler, in this investigation, were not less remarkable than his ingenuity and invention. Logarithms were not yet known, so that arithmetical computation, when pushed to great accuracy, was carried on at a vast expence of time and labour. In the calculation of every opposition of Mars, the work filled ten folio pages, and Kepler repeated each calculation ten times, so that the whole work for each opposition extended to one hundred such pages; seven oppositions thus calculated produced a large folio volume.

In these calculations the introduction of hypotheses was unavoidable, and Kepler's candour in rejecting them, whenever they appeared erroneous, without any other regret than for the time which they had cost him, cannot be sufficiently admired. He began with hypothesis, and ended with rejecting every thing hypothetical. In this great astronomer we find genius, industry, and candour, all uniting together as instruments of investigation.

Though the angular motion of the planet was not found to be uniform, it was discovered that a very simple law connected that motion with the rectilineal distance from the sun, the former being every where inversely as the square of the latter; and hence it was easy to prove, that the area described by the line drawn from the planet to the sun increased at a uniform rate, and, therefore, that any two such areas were proportional to the times in which they were described. The picture presented of the heavens was thus, for the first time, cleared of every thing hypothetical.

The same astronomer was perhaps the first person who conceived that there must be always a law capable of being expressed by arithmetic or geometry, which connects such phenomena as have a physical dependence on one another. His conviction of this truth, and the delight which he appears to have experienced in the contemplation of such laws, led him to seek, with great eagerness, for the relation between the periodical times of the planets, and their distances from the sun. He seems, indeed, to have looked towards this

object with such earnestness, that, while it was not attained, he regarded all his other discoveries as incomplete. He at last found, infinitely to his satisfaction, that in any two planets, the squares of the times of the revolution are as the cubes of their mean distances from the sun. This beautiful and simple law had a value beyond what Kepler could possibly conceive; yet a sort of scientific instinct instructed him in its great importance. He has marked the year and the day when it became known to him; it was on the 8th of May 1618; and perhaps philosophers will agree that there are few days in the scientific history of the world which deserve so well to be remembered.

These great discoveries, however, were not much attended to by the astronomers of that period, or by those who immediately followed. They were but little considered by Cassendi,---they were undervalued by Riccioli,---and were never mentioned by Descartes. It was an honour reserved for Newton to estimate them at their true value.

Indeed, the discoveries of Kepler were at first so far from being duly appreciated, that they were objected to, not for being false, but for offering to astronomers, in the calculation of the place of a planet in its orbit, a problem too difficult to be resolved by elementary geometry. To cut the area of a semi-ellipsis in a given ratio by a line drawn through the focus, is the geometrical problem into which he showed that the above inquiry ultimately resolved. As if he had been answerable for the proceedings of nature, the difficulty of this question was considered as an argument against his theory, and he himself seems somewhat to have felt it as an objection, especially when he found that the best solution he could obtain was no more than an approximation. With all his power of invention, Kepler was a mathematician inferior to many of that period; and though he displayed great ability in the management of this difficult investigation, his solution fell very far short of the simplicity which it was afterwards found capable of attaining.

In addition to all this, he rendered another very important service to the science of astronomy and to the system of Copernicus. Copernicus, it has been already mentioned, had supposed that a force was necessary to enable the earth to preserve the parallelism of its axis during its revolution round the sun. He imagined, therefore, that a third motion belonged to the earth, and that, besides turning on its axis and revolving round the sun, it had another movement by which its axis was preserved always equally inclined to the ecliptic. Kepler was the first to observe that this third motion was quite superfluous, and that the parallelism of the earth's axis, in order to be preserved, required nothing but the absence of all force, as it necessarily proceeded from the inertia of matter, and its tendency to persevere in a state of uniform motion. Kepler had a clear idea of the inertia of body; he was the first who employed the term; and,

considering all motion as naturally rectilinear, he concluded that when a body moves in a curve, it is drawn or forced out of the straight line by the action of some cause, not residing in itself. Thus he prepared the way for physical astronomy, and in these ideas he was earlier than Descartes.

The discoveries of Kepler were secrets extorted from nature by the most profound and laborious research. The astronomical discoveries of Galileo, more brilliant and imposing, were made at a far less expence of intellectual labour. By this it is not meant to say that Galileo did not possess, and did not exert intellectual powers of the very highest order, but it was less in his astronomical discoveries that he had occasion to exert them, than in those which concerned the theory of motion. The telescope turned to the heavens for the first time, in the hands of a man far inferior to the Italian philosopher, must have unfolded a series of wonders to astonish and delight the world.

It was in the year 1609 that the news of a discovery, made in Holland, reached Galileo, viz. that two glasses had been so combined, as greatly to magnify the objects seen through them. More was not told, and more was not necessary to awaken a mind abundantly alive to all that interested the progress either of science or of art. Galileo applied himself to try various combinations of lenses, and he quickly fell on one which made objects appear greater than when seen by the naked eye, in the proportion of three to one. He soon improved on this construction, and found one which magnified thirty-two times, nearly as much as the kind of telescope he used is capable of. That telescope was formed of two lenses; the lens next the object convex, the other concave; the objects were presented upright, and magnified in their lineal dimensions in the proportion just assigned.

Having tried the effect of this combination on terrestrial objects, he next directed it to the moon. What the telescope discovers on the ever-varying face of that luminary, is now well known, and needs not to be described; but the sensations which the view must have communicated to the philosopher who first beheld it, may be conceived more easily than expressed. To the immediate impression which they made upon the sense, to the wonder they excited in all who saw them, was added the proof, which, on reflection, they afforded, of the close resemblance between the earth and the celestial bodies, whose divine nature had been so long and so erroneously contrasted with the ponderous and opaque substance of our globe. The earth and the planets were now proved to be bodies of the same kind, and views were entertained of the universe, more suitable to the simplicity and the magnificence of nature.

When the same philosopher directed his telescope to the fixed stars, if he was disap-

pointed at finding their magnitudes not increased, he was astonished and delighted to find them multiplied in so great a degree, and such numbers brought into view, which were invisible to the naked eye. In Jupiter he perceived a large disk, approaching in size to the moon. Near it, as he saw it for the first time, were three luminous points ranged in a straight line, two of them on one side of the planet, and one on the other. This occasioned no surprise, for they might be small stars not visible to the naked eye, such as he had already discovered in great numbers. By observing them, however, night after night, he found these small stars to be four in number, and to be moons or satellites, accompanying Jupiter, and revolving round him, as the moon revolves round the earth.

The eclipses of these satellites, their conjunctions with the planet, their disappearance behind his disk, their periodical revolutions, and the very problem of distinguishing them from one another, offered, to an astronomer, a series of new and interesting observations.

In Saturn he saw one large disk, with two smaller ones very near it, and diametrically opposite, and always seen in the same places; but more powerful telescopes were required before these appearances could be interpreted.

The horned figure of Venus, and the gibbosity of Mars, added to the evidence of the Copernican system, and verified the conjectures of its author, who had ventured to say, that, if the sense of sight were sufficiently powerful, we should see Mercury and Venus exhibiting phases similar to those of the moon.

The spots of the sun derived an interest from their contrast with the luminous disk over which they seemed to pass. They were found to have such regular periods of return, as could be derived only from the motion of the disk itself; and thus the sun's revolution on his axis, and the time of that revolution, were clearly ascertained.

This succession of noble discoveries, the most splendid, probably, which it ever fell to the lot of one individual to make, in a better age would have entitled its author to the admiration and gratitude of the whole scientific world, but was now viewed from several quarters with suspicion and jealousy. The ability and success with which Galileo had laboured to overturn the doctrines of Aristotle and the schoolmen, as well as to establish the motion of the earth, and the immobility of the sun, had excited many enemies. There are always great numbers who, from habit, indolence, or fear, are the determined supporters of what is established, whether in practice or in opinion. To these the constitution of the universities of Europe, so entirely subjected to the church, had added a numerous and learned phalanx, interested to preserve the old systems, and to resist all innovations which could endanger their authority or their repose. The church itself was roused to action,

by reflecting that it had staked the infallibility of its judgments on the truth of the very opinions which were now in danger of being overthrown. Thus was formed a vast combination of men, not very scrupulous about the means which they used to annoy their adversaries; the power was entirely in their hands, and there was nothing but truth and reason to be opposed to it.

The system of Copernicus, however, while it remained obscure, and known only to astronomers, created no alarm in the church. It had even been ushered into the world at the solicitation of a cardinal, and under the patronage of the Pope; but when it became more popular, when the ability and acuteness of Galileo were enlisted on its side, the consequences became alarming; and it was determined to silence by force an adversary who could not be put down by argument. His dialogues contained a full exposition of the evidence of the earth's motion, and set forth the errors of the old, as well as the discoveries of the new philosophy, with great force of reasoning, and with the charms of the most lively eloquence. They are written, indeed, with such singular felicity, that one reads them at the present day, when the truths contained in them are known and admitted, with all the delight of novelty, and feels one's self carried back to the period when the telescope was first directed to the heavens, and when the earth's motion, with all its train of consequences, was proved for the first time. The author of such a work could not be forgiven. Galileo, accordingly, was twice brought before the Inquisition. The first time a council of seven cardinals pronounced a sentence which, for the sake of those disposed to believe that power can subdue truth, ought never to be forgotten: "That to maintain the sun to be immoveable, and without local motion, in the centre of the world, is an absurd proposition, false in philosophy, heretical in religion, and contrary to the testimony of Scripture. That it is equally absurd and false in philosophy to assert that the earth is not immoveable in the centre of the world, and, considered theologically, equally erroneous and heretical."

These seven theologians might think themselves officially entitled to decide on what was heretical or orthodox in faith, but that they should determine what was true or false in philosophy, was an insolent invasion of a territory into which they had no right to enter, and is a proof how ready men are to suppose themselves wise, merely because they happen to be powerful. At this time a promise was extorted from Galileo, that he would not teach the doctrine of the earth's motion, either by speaking or by writing. To this promise he did not conform. His third dialogue, published, though not till long afterwards, contained such a full display of the beauty and simplicity of the new system, and

such an exposure of the inconsistencies of Ptolemy and Tycho, as completed the triumph of Copernicus.

In the year 1663, Galileo, now seventy years old, being brought before the Inquisition, was forced solemnly to disavow his belief in the earth's motion; and condemned to perpetual imprisonment, though the sentence was afterwards mitigated, and he was allowed to return to Florence.¹ The Court of Rome was very careful to publish this second recantation all over Europe, thinking, no doubt, that it was administering a complete antidote to the belief of the Copernican system. The sentence, indeed, appears to have pressed very heavily on Galileo's mind, and he never afterwards either talked or wrote on the subject of astronomy. Such was the triumph of his enemies, on whom ample vengeance would have long ago been executed, if the indignation and contempt of posterity could reach the mansions of the dead.

Conduct like this, in men professing to be the ministers of religion and the guardians of truth, can give rise to none but the most painful reflections. That an aged philosopher should be forced, laying his hand on the sacred Scriptures, to disavow opinions which he could not cease to hold without ceasing to think, was as much a profanation of religion, as a violation of truth and justice. Was it the act of hypocrites, who considered religion as a state engine, or of bigots, long trained in the art of believing without evidence, or even in opposition to it? These questions it were unnecessary to resolve; but one conclusion cannot be denied, that the indiscreet defenders of religion have often proved its worst enemies.

At length, however, by the improvements, the discoveries, and the reasonings, first of Kepler, and then of Galileo, the evidence of the Copernican system was fully developed, and nothing was wanting to its complete establishment, but time sufficient to allow opinion to come gradually round, and to give men an opportunity of studying the arguments placed before them. Of the adherents of the old system, many had been too long habituated to it to change their views; but as they disappeared from the scene, they were replaced by young astronomers, not under the influence of the same prejudices, and eager to follow doctrines which seemed to offer so many new subjects of investigation. In the next generation the systems of Ptolemy and Tycho had no followers.

It was not astronomy alone which was benefited by this revolution, and the discussions to which it had given rise. A new light, as already remarked, was thrown on the phy-

¹ He was thrown into prison previously to his trial, and attempts were made to render him obnoxious to the people. From the text of a priest who preached against him, we may judge of the wit and the sense with which this persecution was conducted. *Viri Galilæi quid statis in cælum suspicientes?*

sical world, and the curtain was drawn aside which had so long concealed the great experiment, by which nature herself manifests, at every instant, the inertia of body, and the composition of forces. To reconcile the real motion of the earth with its appearance of rest, and with our feeling of its immobility, required such an examination of the nature of motion, as discovered, if not its essence, at least its most general and fundamental properties. The whole science of rational mechanics profited, therefore, essentially by the discovery of the earth's motion.

A great barrier to philosophic improvement had arisen from the separation so early made, and so strenuously supported in the ancient systems, between terrestrial and celestial substances, and between the laws which regulate motion on the earth, and in the heavens. This barrier was now entirely removed; the earth was elevated to the rank of a planet; the planets were reduced to the condition of earths, and by this mutual approach, the same rules of interpretation became applicable to the phenomena of both. Principles derived from experiments on the earth, became guides for the analysis of the heavens, and men were now in a situation to undertake investigations, which the most hardy adventurer in science could not before have dared to imagine. Philosophers had ascended to the knowledge of the affinities which pervade all nature, and which mark so strongly both the wisdom and unity of its author.

The light thus struck out darted its rays into regions the most remote from physical inquiry. When men saw opinions entirely disproved, which were sanctioned by all antiquity, and by the authority of the greatest names, they began to have different notions of the rules of evidence, of the principles of philosophic inquiry, and of the nature of the mind itself. It appeared that science was destined to be continually progressive; provided it was taken for an inviolable maxim, that all opinion must be ultimately amenable to experience and observation.

It was no slight addition to all these advantages, that, in consequence of the discussions from which Galileo had unhappily been so great a sufferer, the line was at length definitely drawn which was to separate the provinces of faith and philosophy from one another. It became a principle, recognised on all hands, that revelation, not being intended to inform men of those things which the unassisted powers of their own understanding would in time be able to discover, had, in speaking of such matters, employed the language and adopted the opinions of the times; and thus the magic circle by which the priest had endeavoured to circumscribe the inquiries of the philosopher entirely disappeared. The reformation in religion which was taking place about the same time, and giving such energy to the human mind, contributed to render this emancipation more

complete, and to reduce the exorbitant pretensions of the Romish church. The prohibition against believing in the true system of the world either ceased altogether, or was reduced to an empty form, by which the affectation of infallibility still preserves the memory of its errors.¹

4. DESCARTES, HUYGENS, &c.

Descartes flourished about this period, and has the merit of being the first who undertook to give an explanation of the celestial motions, or who formed the great and philosophic conception of reducing all the phenomena of the universe to the same law. The time was now arrived when, from the acknowledged assimilation of the planets to the earth, this might be undertaken with some reasonable prospect of success. No such attempt had hitherto been made, unless the crystalline spheres or homocentric orbs of the ancients are to be considered in that light. The conjectures of Kepler about a kind of animation, and of organic structure, which pervaded the planetary regions, were too vague and indefinite, and too little analogous to any thing known on the earth, to be entitled to the name of a theory. To Descartes, therefore, belongs the honour of being the first who ventured on the solution of the most arduous problem which the material world offers to the consideration of philosophy. For this solution he sought no other data than *matter* and *motion*, and with them alone proposed to explain the structure and constitution of the universe. The matter which he required, too, was of the simplest kind, possessing no properties but extension, impenetrability, and inertia. It was matter in the abstract, without any of its peculiar or distinguishing characters. To explain these characters, was indeed a part of the task which he proposed to himself, and thus, by the simplicity of his assumptions, he added infinitely to the difficulty of the problem which he undertook to resolve.

The matter thus constituted was supposed to fill all space, and its parts, both great and small, to be endued with motion in an infinite variety of directions. From the combination of these, the rectilinear motion of the parts become impossible; the atoms or particles of matter were continually diverted from the lines in which they had begun

¹ The learned fathers who have, with so much ability, commented on the *Principia* of Newton, have prefixed to the third book this remarkable declaration:—"Newtonus in hoc tertio libro telluris motæ hypothesin assumit. Auctoris propositiones aliter explicari, non poterant nisi eâdam factâ hypothesi. Hinc alienam coacti sumus gerere personam. *Ceterum latis a summis Pontificibus contra telluris motum Decretis nos obsequi profitemur.*" There is an archness in the last sentence, that looks as if the authors wanted to convey meanings that would differ according to the orthodoxy of the readers.

to move; so that circular motion and centrifugal force originated from their action on one another. Thus matter came to be formed into a multitude of vortices, differing in extent, in velocity, and in density; the more subtile parts constituting the real vortex, in which the denser bodies float, and by which they are pressed, though not equally, on all sides.

Thus the universe consists of a multitude of vortices, which limit and circumscribe one another. The earth and the planets are bodies carried round in the great vortex of the solar system; and by the pressure of the subtile matter, which circulates with great rapidity, and great centrifugal force, the denser bodies, which have less rapidity, and less centrifugal force, are forced down toward the sun, the centre of the vortex. In like manner, each planet is itself the centre of a smaller vortex, by the subtile matter of which the phenomena of gravity are produced, just as with us at the surface of the earth.

The gradation of smaller vortices may be continued in the same manner, to explain the cohesion of the grosser bodies, and their other sensible qualities. But I forbear to enter into the detail of a system, which is now entirely exploded, and so inconsistent with the views of nature which have become familiar to every one, that such details can hardly be listened to with patience. Indeed, the theory of vortices did not explain a single phenomenon in a satisfactory manner, nor is there a truth of any kind which has been brought to light by means of it. None of the peculiar properties of the planetary orbits were taken into the account; none of the laws of Kepler were considered; nor was any explanation given of those laws, more than of any other that might be imagined. The philosophy of Descartes could explain all things equally well, and might have been accommodated to the systems of Ptolemy or Tycho, just as well as to that of Copernicus. It forms, therefore, no link in the chain of physical discovery; it served the cause of truth only by exploding errors more pernicious than its own; by exhausting a source of deception, which might have misled other adventurers in science, and by leaving a striking proof how little advancement can be made in philosophy, by pursuing any path but that of experiment and induction. Descartes was, nevertheless, a man of great genius, a deep thinker, of enlarged views, and entirely superior to prejudice. Yet, in as far as the explanation of astronomical phenomena is concerned (and it was his main object), he did good only by showing in what quarter the attempt could not be made with success; he was the forlorn hope of the new philosophy, and must be sacrificed for the benefit of those who were to follow.

Gassendi, the contemporary and countryman of Descartes, possessed great learning, with a very clear and sound understanding. He was a good observer, and an enlightened

advocate of the Copernican system. He explained, in a very satisfactory manner, the connection between the laws of motion and the motion of the earth, and made experiments to show, that a body carried along by another acquires a motion which remains after it has ceased to be so carried. Gassendi first observed the transit of a planet over the disk of the sun,—that of Mercury, in 1631. Kepler had predicted this transit, but did not live to enjoy a spectacle which afforded so satisfactory a proof of the truth of his system, and of the accuracy of his astronomical tables.

The first transit of Venus, which was observed, happened a few years later, in 1639, when it was seen in England by Horrox, and his friend Crabtree, and by them only. Horrox, who was a young man of great genius, had himself calculated the transit, and foretold the time very accurately, though the astronomical tables of that day gave different results, and those of Kepler, in which he confided the most, were, in this instance, considerably in error. Horrox has also the merit of being among the first who rightly appreciated the discoveries of the astronomer just named. He had devoted much time to astronomical observation, and, though he died very young, he left behind him some preparations for computing tables of the moon, on a principle which was new, and which Newton himself thought worthy of being adopted in his theory of the inequalities of that planet.

The first complete system of astronomy, in which the elliptic orbits were introduced, was the *Astronomia Philolaica* of Bullialdus (Bouillaud), published in 1645. They were introduced, however, with such hypothetical additions, as show that the idea of a centre of uniform motion had not yet entirely disappeared. It is an idea, indeed, which gives considerable relief to the imagination, and it besides leads to methods of calculation more simple than the true theory, and Bullialdus may have flattered himself that they were sufficiently exact. He conceives the elliptic orbit as a section of an oblique cone, the axis of which passes through the superior focus of the ellipse, while the planet moves in its circumference in such a manner, that a plane passing through it and through the axis, shall be carried round with a uniform angular velocity. It is plain that the cone and its axis are mere fictions, arbitrarily assumed, and not even possessing the advantage of simplicity. The author himself departs from this hypothesis, and calculates the places of a planet, on the supposition that it moves in the circumference of an epicycle, and the epicycle in the circumference of an eccentric deferent, both angular motions being uniform, that of the planet in the epicycle being retrograde, and double the other. The figure thus described may be shown to be an ellipse, but the line drawn from the planet to the focus does not cut off areas proportional to the time.

An hypothesis advanced by Ward, Bishop of Salisbury, was simpler and more accurate than that of the French astronomer. According to it, the line drawn from a planet to the superior focus of its elliptic orbit, turns with a uniform angular velocity round that point. In orbits of small eccentricity, this is nearly true, and almost coincides in such cases with Kepler's principle of the uniform description of areas. Dr Ward, however, did not consider the matter in that light; he assumed his hypothesis as true, guided, it would seem, by nothing but the opinion, that a centre of uniform motion must somewhere exist, and pleased with the simplicity thus introduced into astronomical calculation. It is, indeed, remarkable, as Montucla has observed, how little the most enlightened astronomers of that time seem to have studied or understood the laws discovered by Kepler. Riccioli, of whom we are just about to speak, enumerates all the suppositions that had been laid down concerning the velocities of the planets, but makes no mention of their describing equal areas in equal times round the sun. Even Cassini, great as he was in astronomy, cannot be entirely exempted from this censure.

Riccioli, a good observer, and a learned and diligent compiler, has collected all that was known in astronomy about the middle of the seventeenth century, in a voluminous work, the *New Almagest*. Without much originality, he was a very useful author, having had, as the historian of astronomy remarks, the courage and the industry to read, to know, and to abridge every thing. He was, nevertheless, an enemy to the Copernican system, and has the discredit of having measured the evidence for and against that system, not by the weight, but by the number of the arguments. The pains which he took to prop the falling edifice of deferents and epicycles, added to his misapprehending and depreciating the discoveries of Kepler, subject him to the reproach of having neither the genius to discover truth, nor the good sense to distinguish it when discovered. He was, however, a priest and a jesuit; he had seen the fate of Galileo; and his errors may have arisen from want of courage, more than from want of discernment.

Of the phenomena which the telescope in the hands of Galileo had made known, the most paradoxical were those exhibited by Saturn; sometimes attended by two globes, one on each side, without any relative motion, but which would, at stated times, disappear for a while, and leave the planet single, like the other heavenly bodies. Nearly forty years had elapsed, without any farther insight into these mysterious appearances, when Huygens began to examine the heavens with telescopes of his own construction, better and more powerful than any which had yet been employed. The two globes that had appeared insulated, were now seen connected by a circular and luminous belt, going quite round the planet. At last, it was found that all these appearances resulted from a broad ring surrounding

Saturn, and seen obliquely from the earth. The gradual manner in which this truth unfolded itself is very interesting, and has been given with the detail that it deserves by Huygens, in his *Systema Saturnium*.

The attention which Huygens had paid to the ring of Saturn, led him to the discovery of a satellite of the same planet. His telescopes were not powerful enough to discover more of them than one; he believed, indeed, that there were no more, and that the number of the planets now discovered was complete. The reasoning by which he convinced himself, is a proof how slowly men are cured of their prejudices, even with the best talents and the best information. The planets, primary and secondary, thus made up twelve, the double of six, the first of the perfect numbers. In 1671, however, Cassini discovered another satellite, and afterwards three more, making five in all, which the more perfect telescopes of Dr Herschell have lately augmented to seven.

To the genius of Huygens astronomy is indebted for an addition to its apparatus, hardly less essential than the quadrant and the telescope. An accurate measure of time is of use even in the ordinary business of life, but to the astronomer is infinitely valuable. The dates of his observations, and an accurate estimate of the time elapsed between them, is necessary, in order to make them lead to any useful consequences. Besides this, the only way of measuring with accuracy those arches in the heavens, which extend from east to west, or which are parallel to the equator, depends on the earth's rotation, because such an arch bears the same proportion to the entire circumference of a circle, that the time of its passage under the meridian bears to an entire day. The reckoning of time thus furnishes the best measure of position, as determined by arches parallel to the equator, whether on the earth or in the heavens.

Though the pendulum afforded a measure of time, in itself of the greatest exactness, the means of continuing its motion, without disturbing the time of its vibrations, was yet required to be found, and this, by means of the clock, Huygens contrived most ingeniously to effect. Each vibration of the pendulum, by means of an arm at right angles to it, allows the tooth of a wheel to escape, the wheel being put in motion by a weight. The wheel is so contrived, that the force with which it acts is just sufficient to restore to the pendulum the motion which it had lost by the resistance of the air, and the friction at the centre of motion. Thus the motion of the clock is continued without any diminution of its uniformity, for any length of time.

The telescope had not yet served astronomy in all the capacities in which it could be useful. Huygens, of whose inventive genius the history of science has so much to record, applied it to the measurement of small angles, forming it into the instrument which has

since been called a micrometer. By introducing into the focus of the telescope a round aperture of a given size, he contrived to measure the angle which that aperture subtended to the eye, by observing the time that a star placed near the equator required to traverse it. When the angle subtended by any other object in the telescope was to be measured, he introduced into the focus a thin piece of metal, just sufficient to cover the object in the focus. The proportion of the breadth of this plate, to the diameter of the aperture formerly measured, gave the angle subtended by the image in the focus of the telescope. This contrivance is described in the *Systema Saturnium*, at the end.

The telescope has farther contributed materially to the accuracy of astronomical observation, by its application to instruments used for measuring, not merely small angles, but angles of any magnitude whatever. The telescope here comes in place of the plain sights with which the index or *alidada* of an instrument used to be directed to an object, and this substitution has been accompanied with two advantages. The disk of a star is never so well defined to the naked eye as it is in the telescope. Besides, in using plain sights, the eye adapts itself to the farther off of the two, in order that its aperture may be distinctly seen. Whenever this adjustment is made, the object seen through the aperture necessarily appears indistinct to the eye, which is then adapted to a near object. This circumstance produces an uncertainty in all such observations, which, by the use of the telescope, is entirely removed.

But the greatest advantage arises from the magnifying power of the telescope, from which it follows, that what is a mere point to the naked eye, is an extended line which can be divided into a great number of parts when seen through the former. The best eye, when not aided by glasses, is not able to perceive an object which subtends an angle less than half a minute, or thirty seconds. When the index of a quadrant, therefore, is directed by the naked eye to any point in the heavens, we cannot be sure that it is nearer than half a minute on either side of that point. But when we direct the axis of a telescope, which magnifies thirty times, to the same object, we are sure that it is within the thirtieth part of half a minute, that is, within one second of the point aimed at. Thus the accuracy *cæteris paribus* is proportional to the magnifying power.

The application of the telescope, however, to astronomical instruments, was not introduced without opposition. Hevelius of Dantzic, the greatest observer who had been since Tycho Brahé, who had furnished his observatory with the best and largest instruments, and who was familiar with the use of the telescope, strenuously maintained the superiority of the plain sights. His principal argument was founded on this,—that, in plain sights, the line of collimation is determined in its position by two fixed points at a considerable

distance from one another, viz. the centres of the two apertures of the sights, so that it remains invariable with respect to the index.

In the case of the telescope there was one fixed point, the intersection of the wires in the focus of the eye-glass; but Hevelius did not think that the other point, viz. the optical centre of the object-glass, was equally well defined. This doubt, however, might have been removed by a direct appeal to experiment, or to angles actually measured on the ground, first by an instrument, and then by trigonometrical operations. From thence it would soon have been discovered, that the centre of a lens is in fact a point defined more accurately than can be done by any mechanical construction.

This method of deciding the question was not resorted to. Hevelius and Hooke had a very serious controversy concerning it, in which the advantage remained with the latter. It should have been observed that the French astronomer, Picard, was the first who employed instruments furnished with telescopic sights, about the year 1665. It appears, however, that Gascoigne, an English gentleman who fell at the battle of Marston-moor in 1644, had anticipated the French astronomer in this invention, but that it had remained entirely unknown. He had also anticipated the invention of the micrometer. The vast additional accuracy thus given to instruments formed a new era in the history of astronomical observations.

Though Galileo had discovered the satellites of Jupiter, their times of revolution, and even some of their inequalities, it yet remained to define their motions with precision, and to construct tables for calculating their places. This task was performed by the elder Cassini, who was invited from Italy, his native country, by Louis the Fourteenth, and settled in France in 1669. His tables of the satellites had been published at Bologna three years before, and he continued to improve them, by a series of observations made in the observatory at Paris, with great diligence and accuracy.

The theory of the motions of these small bodies is a research of great difficulty, and had been attempted by many astronomers before Cassini, with very little success. The planes of the orbits, their inclinations to the orbit of Jupiter, and the lines in which they intersected that orbit, were all to be determined, as well as the times of revolution, and the distances of each from its primary. Add to this, that it is only in a few points of their orbits that they can be observed with advantage. The best are at the times of immersion into the shadow of Jupiter, and emersion from it. The same excellent astronomer discovered four satellites of Saturn, in addition to that already observed by Huygens. He also discovered the rotation of Jupiter and of Mars upon their axes.

The constant attention bestowed on the eclipses of the satellites of Jupiter, made an

inequality be remarked in the periods of their return, which seemed to depend on the position of the earth relatively to Jupiter and the sun, and not, as the inequalities of that sort might have been expected to do, on the place of Jupiter in his orbit. From the opposition of Jupiter to the sun, till the conjunction, it was found, that the observed emersion of the satellites from the shadow fell more and more behind the computed; the differences amounting near the conjunction to about fourteen minutes. When, after the conjunction, the immersions were observed, an acceleration was remarked just equal to the former retardation, so that, at the opposition, the eclipse happened fourteen minutes sooner than by the calculation.

The first person who offered an explanation of these facts was Olaus Roemer, a Danish astronomer. He observed that the increase of the retardation corresponded nearly to the increase of the earth's distance from Jupiter, and conversely, the acceleration to the diminution of that distance. Hence it occurred to him, that it was to the time which light requires to traverse those distances that the whole series of phenomena was to be ascribed. This explanation was so simple and satisfactory, that it was readily received.

Though Roemer was the first who communicated this explanation to the world, yet it seems certain that it had before occurred to Cassini, and that he was prevented from making it known by a consideration which does him great honour. The explanation which the motion of light afforded, seemed not to be consistent with two circumstances involved in the phenomenon. If such was the cause of the alternate acceleration and retardation above described, why was it observed only in the eclipses of the first satellite, and not in those of the other three? This difficulty appeared so great to Cassini, that he suppressed the explanation which he would otherwise have given.

The other difficulty occurred to Maraldi. Why did not an equation or allowance of the same kind arise from the position of Jupiter, with respect to his aphelion, for, all other things being the same, his distance from the earth must be greater, as he was nearer to that point of his orbit? Both these difficulties have since been completely removed. If the aforesaid inequality was not for sometime observed in any satellite but the first, it was only because the motions of the first are the most regular, and were the soonest understood, but it now appears that the same equation belongs to all the satellites. The solution of Maraldi's difficulty is similar; for the quantity of what is called the equation of the light, is now known to be affected by Jupiter's place in his orbit.

Thus, every thing conspires to prove the reality of the motion of light, so singular on account of the immensity of the velocity, and the smallness of the bodies to which it is communicated.

5. ESTABLISHMENT OF ACADEMIES, &c.

About the middle of the seventeenth century were formed those associations of scientific men, which, under the appellation of Academies or Philosophical Societies, have contributed so much to the advancement of knowledge in Europe. The *Accademia del Cimento* of Florence, founded in 1651, carried in its name the impression of the new philosophy. It was in the country of Galileo where the first institution for the prosecution of experimental knowledge might be expected to arise, and the monuments which it has left behind it will ever create regret for the shortness of its duration.

England soon after showed the same example. It has been already remarked, that, during the civil wars, a number of learned and scientific men sought, in the retirement of Oxford, an asylum from the troubles to which the country was then a prey. They had met as early as 1645; most of them were attached to the royal cause; and after the restoration of Charles the Second, they were incorporated by a royal charter in 1662.

The first idea of this institution seems to have been suggested by the writings of Bacon, who, in recommending the use of experiment, had severely censured the schools, colleges, and academies of his own time, as adverse to the advancement of knowledge; and, in the *Nova Atlantis*, had given a most interesting sketch of the form of a society, directed to scientific improvement. In Germany, the *Accademia Naturæ Curiosorum* dates its commencement from 1652, and the historian of that institution ascribes the spirit

¹ "In meribus et institutis scholarum, academiarum, collegiorum, et similium conventuum quæ doctorum hominum sedibus et eruditionis culturæ destinata sunt, omnia progressui scientiarum adversa inveniuntur. Lectiones enim exercitia ita sunt disposita, ut aliud a consuetis haud facile cuiquam in mentem veniat cogitare, aut contemplari. Si vero unus aut alter fortasse iudicii libertate uti sustinuerit, is sibi soli hanc operam imponere possit; ab aliorum autem consortio nihil capiet utilitatis. Sin et hoc toleraverit, tamen in capessenda fortuna industriam hanc et magnanimitatem sibi non levi impedimento fore experietur. Studia enim hominum in ejusmodi locis, in quorundam auctorum scripta, veluti in carceres, conclusa sunt; a quibus si quis dissentiat, continuo ut homo turbidus et rerum novarum cupidus corripitur. In artibus autem et scientiis tanquam in metalli-fodinis omnia novis operibus et ulterioribus progressibus circumstrepere debent."—*Nov. Org.* lib. i. cap. 90.

It would be gratifying to be able to observe, that the universities of Europe had contributed to the renovation of science. The fact is otherwise;—they were often the fastnesses from which prejudice and error were latest of being expelled. They joined in persecuting the reformers of science. It has been seen, that the masters of the university of Paris were angry with Galileo for the experiments on the descent of bodies. Even the university of Oxford brought on itself the indelible disgrace of persecuting, in Friar Bacon, the first man who appears to have had a distinct view of the means by which the knowledge of the laws of nature must be acquired.

which produced it to the writings of the philosopher just named. These examples, and a feeling that the union and co-operation of numbers was necessary to the progress of experimental philosophy, operated still more extensively. The Royal Academy of Sciences at Paris was founded in 1666, in the reign of Louis the Fourteenth, and during the administration of Colbert. The Institute of Bologna in Italy belongs nearly to the same period; but almost all the other philosophical associations, of which there are now so many, had their beginning in the eighteenth century.

Frequent communication of ideas, and a regular method of keeping up such communication, are evidently essential to works in which great labour and industry are to be employed, and to which much time must necessarily be devoted; when the philosopher must not always sit quietly in his cabinet, but must examine nature with his own eyes, and be present in the work-shop of the mechanic, or the laboratory of the chemist. These operations are facilitated by the institutions now referred to, which, therefore, are of more importance to the physical sciences than to the other branches of knowledge. They who cultivate the former are also fewer in number, and being, of course, farther separated, are less apt to meet together in the common intercourse of the world. The historian, the critic, the poet, finds everywhere men who can enter in some degree at least into his pursuits, who can appreciate his merit, and derive pleasure from his writings or his conversation. The mathematician, the astronomer, the mechanician, sees few men who have much sympathy with his pursuits, or who do not look with indifference on the objects which he pursues. The *world*, to him, consists of a few individuals, by the censures or approbation of whom the public opinion must be finally determined; with them it is material that he should have more frequent intercourse than could be obtained by casual encounter; and he feels that the society of men engaged in pursuits similar to his own, is a necessary *stimulus* to his exertions. Add to this, that such societies become centers in which information concerning facts is collected from all quarters. For all these reasons, the greatest benefit has resulted from the scientific institutions which, since the middle of the seventeenth century, have become so numerous in Europe.

The Royal Society of London is an association of men, who, without salaries or appointment from Government, defray, by private contribution, the expence of their meetings, and of their publications. This last is another important service, which a society so constituted renders to science.

The demand of the public for memoirs in mathematics and natural philosophy, many of them perhaps profound and difficult, is not sufficiently great to defray the expence of pub-

lication, if they come forward separately and unconnected with one another. In a collective state they are much more likely to draw the attention of the public; the form in which they appear is the most convenient both for the reader and the author; and if, after all, the sale of the work is unequal to the expence, the deficiency is made up from the funds of the society. An institution of this kind, therefore, is a patriotic and disinterested association of the lovers of science, who engage not only to employ themselves in discovery, but, by private contribution, to defray the expence of scientific publications.

The Academy of Sciences in Paris was not exactly an institution of the same kind. It consisted of three classes of members, one of which, the *Pensionnaires*, twenty in number, had salaries paid by Government, and were bound in their turns to furnish the meetings with scientific memoirs, and each of them also, at the beginning of every year, was expected to give an account of the work in which he was to be employed. This institution has been of incredible advantage to science. To detach a number of ingenious men from every thing but scientific pursuits; to deliver them alike from the embarrassments of poverty or the temptations of wealth; to give them a place and station in society the most respectable and independent, is to remove every impediment, and to add every stimulus to exertion. To this institution, accordingly, operating upon a people of great genius, and indefatigable activity of mind, we are to ascribe that superiority in the mathematical sciences, which, for the last seventy years, has been so conspicuous.

The establishment of astronomical observatories, as national or royal works, is connected in Europe with the institution of scientific or philosophical societies. The necessity of the former was, indeed, even more apparent than that of the latter. A science, which has the heavenly bodies for its objects, ought, as far as possible, to be exempted from the vicissitudes of the earth. As it gains strength but slowly, and requires ages to complete its discoveries, the plan of observation must not be limited by the life of the individual who pursues it, but must be followed out in the same place, year after year, to an unlimited extent. A perception of this truth, however indistinct, seems, from the earliest times, to have suggested the utility of observatories, to those sovereigns who patronised astronomy, whether they looked to that science for real or imaginary instruction. The circle of Osymandias is the subject of one of the most ancient traditions in science, and has preserved the name of a prince which otherwise would have been entirely unknown. A building, dedicated to astronomy, made a conspicuous part of the magnificent establishment of the school of Alexandria. During the middle ages, in the course of the migrations of science toward the east, sumptuous buildings, furnished with astronomical instruments, rose successively in the plains of Me-

sopotamia, and among the mountains of Tartary. An observatory in the gardens of the Caliph of Bagdat contained a quadrant of fifteen cubits¹ in radius, and a sextant of forty.² Instruments of a still larger size distinguished the observatory of Samarcande, and the accounts would seem incredible, if the ruins of Benares did not, at this moment, attest the reality of similar constructions.

On the revival of letters in Europe, establishments of the same kind were the first decisive indications of a taste for science. We have seen the magnificent observatory on which Tycho expended his private fortune, and employed the munificence of his patron, become a sad memorial (after the signal services which it had rendered to astronomy) of the instability of whatever depends on individual greatness. The observatories at Paris and London were secured from a similar fate, by being made national establishments, where a succession of astronomers were to devote themselves to the study of the heavens. The observatory at Paris was begun in 1667, and that at Greenwich in 1675. In the first of these, La Hire and Cassini, in the second, Flamstead and Halley, are at the head of a series of successors, who have done honour to their respective nations. If there be in Britain any establishment, in the success and conduct of which the nation has reason to boast, it is that of the Royal Observatory, which, in spite of a climate which so continually tries the patience, and so often disappoints the hopes of the astronomer, has furnished a greater number of observations to be completely relied on, than all the rest of Europe put together, and afforded the *data* for those tables, in which the French mathematicians have expressed, with such accuracy, the past, the present, and the future condition of the heavens.

6. FIGURE AND MAGNITUDE OF THE EARTH.

The progress made during the seventeenth century, in ascertaining the magnitude and figure of the earth, is particularly connected with the establishments which we have just been considering. Concerning the figure of the earth, no accurate information was derived from antiquity, if we except that of the mathematical principle on which it was to be determined. The measurement of an arch of the meridian was attempted by Eratosthenes of Alexandria, in perfect conformity with that principle, but by means very inadequate to the importance and difficulty of the problem. By measuring the sun's distance from the zenith of Alexandria, on the solstitial day, and by knowing, as he thought

¹ Twenty-two feet three inches.

² Sixty feet five inches.

he did, that, on the same day, the sun was exactly in the zenith of Syené, he found the distance in the heavens between the parallels of those places to be $7^{\circ} 12'$, or a 50th part of the circumference of a great circle. Supposing, then, that Alexandria and Syené were in the same meridian, nothing more was required than to find the distance between them, which, when multiplied by 50, would give the circumference of the globe. The manner in which this was attempted by Eratosthenes is quite characteristic of the infant state of the arts of experiment and observation. He took no trouble to ascertain whether Alexandria and Syené were due north and south of one another: the truth is, that the latter is considerably east of the former, so that, though their horizontal distance had been accurately known, a considerable reduction would have been necessary, on account of the distance of the one from the meridian of the other. It does not appear, however, that Eratosthenes was at any more pains to ascertain the distance than the bearing of the two places. He assumed the former just as it was commonly estimated; and, indeed, it appears that the distance was not measured till long afterwards, when it was done by the command of Nero.

It was in this way that the ancients made observations and experiments; the mathematical principles might be perfectly understood, but the method of obtaining accurate data for the application of those principles was not a subject of attention. The *power* of resolving the problem was the main object; and the actual solution was a matter of very inferior importance. The slowness with which the art of making accurate experiments and observations has been matured, and the great distance it has kept behind theory, is a remarkable fact in the history of the physical sciences. It has been remarked, that mathematicians had found out the area of the circle, and calculated its circumference to more than a hundred places of decimals, before artists had divided an arch into minutes of a degree; and that many excellent treatises had been written on the properties of curves, before a straight line had been drawn of any considerable length, or measured with any tolerable exactness, on the surface of the globe.¹

The next measurement on record is that of the astronomers of Almamon, in the plains of Mesopotamia, and the manner of conducting the operation appears to have been far more accurate than that of the Greek philosophers; but, from a want of knowledge of the *measures* employed, it has conveyed no information to posterity.

¹ Edinburgh Review, Vol. V. p. 391.

The first arch of the meridian measured in modern times with an accuracy any way corresponding to the difficulty of the problem, was by Snellius, a Dutch mathematician, who has given an account of it in a volume which he calls *Eratosthenes Batavus*, published in 1617. The arch was between Bergen-op-zoom and Alkmaar; its amplitude was $1^{\circ} 11' 30''$, and the distance was determined by a series of triangles, depending on a base line carefully measured. The length of the degree that resulted was 55,021 toises, which, as was afterwards found, is considerably too small. Certain errors were discovered, and when they were corrected, the degree came out 57,033 toises, which is not far from the truth. The corrections were made by Snellius himself, who measured his base over again, and also the angles of the triangles. He died, however, before he could publish the result. Muschenbroek, who calculated the whole anew from his papers, came to the conclusion just mentioned, which, of course, was not known till long after the time when the measure was executed. No advantage, accordingly, was derived to the world from this measurement till its value was lost in that of other measurements still more accurately conducted.

A computation which, for the time, deserves considerable praise, is that of Norwood, in 1635, who measured the distance between London and York, taking the bearings as he proceeded along the road, and reducing all to the direction of the meridian, and to the horizontal plane. The difference of latitude he found, by observation of the solstices, to be $2^{\circ} 28'$, and from that and his measured distance, he concluded the degree to be 867,176 feet English, or 57,800 toises. This has been found to be a near approximation; yet his method was not capable of great accuracy, nor did he always execute it in the best manner. "Sometimes," says he, "I measured, sometimes I *paced*, and I believe I am within a *scantling* of the truth."

Fernel, a French physician, measured with a wheel from Paris to Amiens, which are nearly in the same meridian, and he determined the degree from thence to be 56,746 French toises; a result which falls short of the truth, though not very considerably.

These investigations, it is plain, could not but leave considerable uncertainty with respect to the magnitude of the earth. The Academy of Sciences became interested in the question, and the measurement of an arch in the meridian was undertaken under its auspices, and executed by the Abbé Picard, already known for his skill in the operations of practical geometry. He followed a method similar to that of Snellius, according to which, the distance between Amiens and Malvoisine was found from a series of triangles, and a base of $5668\frac{1}{2}$ toises. He determined the difference of latitude by means of a zenith sector of ten feet radius, and found it to be $1^{\circ} 22' 55''$. The whole distance was 78,850 toises,

whence the degree came out 57,060 toises. This was the first measurement of a degree of the meridian, on which perfect reliance could be placed.

Hitherto no doubt had been entertained of the spherical figure of the earth, and, of consequence, of the equality of all the degrees of the meridian, so that if one was known, the whole circumference was determined. Men, with the precipitation which they so often manifest, of assuming, without sufficient evidence, the conclusion which appears most simple, were no sooner satisfied that the earth was round, than they supposed it to be truly spherical. An observation soon occurred, which gave reason to suspect, that much more must be done before its figure or its magnitude were completely ascertained.

With a view of observing the sun's altitude in the vicinity of the equator, where the distance from the zenith being inconsiderable, the effects of refraction must be of small account, it was agreed, by the same academy, to send an astronomer, M. Richer, to make observations at the island of Cayenne, in South America.

Richer observed the solstitial altitude of the sun at that place in 1672, and found the distance of the tropics to be $46^{\circ} 57' 4''$; and, therefore, the obliquity of the ecliptic $23^{\circ} 28' 32''$, agreeing almost precisely with the determination of Cassini.

The most remarkable circumstance, however, which occurred in the course of this voyage, was, that the clock, though furnished with a pendulum of the same length which vibrated seconds at Paris, was found, at Cayenne, to lose two minutes and a half a-day nearly. This created great astonishment in France, especially after the accuracy of it was confirmed by the observations of Varin and Deshayes, who, some years afterwards, visited different places on the coast of Africa and America, near the line, and found the necessity of shortening the pendulum, to make it vibrate seconds in those latitudes. The first explanation of this remarkable phenomenon was given by Newton, in the third book of his *Principia*, published in 1687, where it is deduced as a necessary consequence of the earth's rotation on its axis, and of the centrifugal force thence arising. That force changes both the direction and the intensity of gravity, giving to the earth an oblate spheroidal figure, more elevated at the equator than the poles, and making bodies fall, and pendulums vibrate, more slowly in low than in high latitudes.

This solution, however, did not, any more than the book in which it was contained, make its way very readily into France. The first explanation of the retardation of the pendulum, which was received there, was given by Huygens in 1690. Huygens deduced it also from the centrifugal force, arising from the earth's rotation, and the view which he took was simpler, though much less accurate than that of Newton. It had, indeed, the simplicity which often arises from neglecting one of the essential conditions of a problem;

but it was nevertheless ingenious, and involved a very accurate knowledge of the nature of centrifugal force. I am thus brought to touch on a subject which belongs properly to the second part of this Dissertation, for which the fuller discussion of it must of course be reserved.

SECTION V.

OPTICS.

1. OPTICAL KNOWLEDGE OF THE ANCIENTS.

ON account of the rectilinear propagation of light, the phenomena of optics are easily expressed in the form of mathematical propositions, and seem, as it were, spontaneously to offer themselves to the study of geometers. Euclid perceiving this affinity, began to apply the science which he had already cultivated with so much success, to explain the laws of vision, before a similar attempt had been made with respect to any other branch of terrestrial physics, and at least fifty years before the researches of Archimedes had placed mechanics among the number of the mathematical sciences.

In the treatise ascribed to Euclid, there are, however, only two physical principles which have completely stood the test of subsequent improvement. The first of these is the proposition just referred to, that a point in any object is seen in the direction of a straight line drawn from the eye to that point; and the second is, that when a point in an object is seen by reflection from a polished surface, the lines drawn from the eye and from the object to the point whence the reflection is made, are equally inclined to the reflecting surface. These propositions are assumed as true; they were, no doubt, known before the time of Euclid, and it is supposed that the discovery of them was the work of the Platonic school. The first of them is the foundation of *Optics proper*, or the theory of vision by direct light; the second is the foundation of *Catoptrics*, or the theory of vision by reflected light. *Dioptrics*, or vision by refracted light, had not yet become an object of attention.

Two other principles which Euclid adopted as postulates in his demonstrations, have not met with the same entire confirmation from experiment, and are, indeed, true only in certain cases, and not universally, as he supposed. The first of these is, that we judge of the magnitude of an object altogether by the magnitude of the optical angle, or the angle which it subtends at the eye. It is true that this angle is an important ele-

ment in that judgment, and Euclid, by discovering this, came into the possession of a valuable truth ; but by a species of sophistry, very congenial to the human mind, he extended the principle too far, and supposed it to be the only circumstance which determines our judgment of visible magnitude. It is, indeed, the only measure which we are furnished with directly by the eye itself ; but there are few cases in which we form our estimate without first appealing to the commentary afforded by the sensations of touch, or the corrections derived from our own motion.

Another principle, laid down by the same geometer, is in circumstances nearly similar to the preceding. According to it, the place of any point of an object seen by reflection, is always the intersection of the reflected ray, with the perpendicular drawn from that point to the reflecting surface. The proof offered is obscure and defective ; the proposition, however, is true, of plain speculums always, and of spherical as far as Euclid's investigations extended, that is, while the rays fall on the speculum with no great obliquity. His assumption, therefore, did not affect the truth of his conclusions, though it would have been a very unsafe guide in more general investigations. The book is in many other respects imperfect, the reasoning often unsound, and the whole hardly worthy of the great geometer whose name it bears. There is, however, no doubt that Euclid wrote on the subject of optics, and many have supposed that this treatise is a careless extract, or an unskilful abridgment of the original work.

Antiquity furnished another mathematical treatise on optics, that of the astronomer Ptolemy. This treatise, though known in the middle ages, and quoted by Roger Bacon, had disappeared, and was supposed to be entirely lost, till within these few years, when a manuscript on optics, professing to be the work of Ptolemy, and to be translated from the Arabic, was found in the King's Library at Paris. The most valuable part of this work is that which relates to refraction, from whence it appears that many experiments had been made on that subject, and the angles of incidence and refraction, for different transparent substances, observed with so much accuracy, that the same ratio very nearly of the sines of these angles, from air into water, or into glass, is obtained from Ptolemy's numbers, which the repeated experiments of later times have shown to be true. The work, however, in the state in which it now appears, is very obscure, the reasoning often deficient in accuracy, and the mathematical part much less perfect than might have been expected. Modern writers, presuming partly on the reputation of Ptolemy, and partly guided by the authority of Roger Bacon, had ascribed to this treatise more merit than it appears to possess ; and, of consequence, had allowed less to the Arabian author Alhazen, who comes next in the order of time, than of right belongs to him. Montucla, on the

authority of Bacon, says, that Ptolemy ascribed the increase of the apparent magnitude of the heavenly bodies near the horizon, to the greater distance at which they are supposed to be, on account of the number of intervening objects across which they are seen. Ptolemy's explanation, however, as stated by Delambre, ¹ from the manuscript just mentioned, is quite different from this, and amounts to no more than the vague and unsatisfactory remark, that an observer looks at the bodies near the zenith in a constrained posture, and in a situation to which the eye is not accustomed. The former explanation, therefore, given by Alhazen, but supposed to have been borrowed from Ptolemy, must now be returned to its right owner. It is the best explanation yet known.

These are the only mathematical treatises on optics of any consideration which the ancients have transmitted to us; ² but many metaphysical speculations on light and vision are to be found in the writings of the philosophers. Aristotle defined light much as he had defined motion; *the act or energy of a transparent body, in as much as it is transparent.* The reason for calling light an act of a transparent body is, that, though a body may be transparent in power or capacity, it does not become actually transparent but by means of light. Light brings the transparency into action; it is, therefore, the act of a transparent body. In such miserable puerilities did the genius of this great man exhaust itself, owing to the unfortunate direction in which his researches were carried on.

In his farther speculations concerning light, he denied it to be a substance; and his argument contains a singular mixture of the ingenious and the absurd. The time, he says, in which light spreads from one place to another is infinitely small, so that light has a velocity which is infinitely great. Now, bodies move with a velocity inversely as the quantities of matter which they contain; light, therefore, cannot contain any mat-

¹ *Connaissance des Temps*, 1816, p. 345, &c. The glimpses of truth, not destined to be fully discovered till many ages afterwards, which are found in the writings of the ancients, are always interesting. Ptolemy distinguishes what has since been called the *virtual focus*, which takes place in certain cases of reflection from spherical specula. He remarks, that colours are confounded by the rapidity of motion, and gives the instance of a wheel painted with different colours, and turned quickly round.

² Another Greek treatise on optics, that of *Heliodorus of Larissa*, has been preserved, and was first published by Erasmus Bartholinus at Paris, in 1657. It is a superficial work, which, to a good deal of obscure and unsound metaphysics, adds the demonstration of a few very obvious truths. The author holds the opinion, that vision is performed by the emission of something from the eyes; and the reason which he assigns is, that the eyes are convex, and more adapted to emit than to receive. His metaphysics may be judged of from this specimen. He has not been made mention of by any ancient author, and the time when he wrote is unknown. As he quotes, however, the writings of Ptolemy and Hero, he must have been later than the first century.

ter, that is, it cannot be material.' That the velocity of light was infinitely great, seemed to him to follow from this, that its progress, estimated either in the direction of north and south, or of east and west, appeared to be instantaneous. In the opinion of the Platonists, and of the greater part of the ancients, vision was performed by means of certain rays which proceeded from the eye to the object, though they did not become the instruments of conveying sensations to the mind, but in consequence of the presence of light. In this theory, we can now see nothing but a rude and hasty attempt to assimilate the sense of sight to that of touch, without inquiring sufficiently into the particular characters of either.

Epicurus, and the philosophers of his school, as we learn from Lucretius, entertained more correct notions of vision, though they were still far from the truth. They conceived vision to be performed in consequence of certain *simulacra*, or images continually thrown off from the surfaces of bodies, and entering the eye. This was the substitute in their philosophy for rays of light, and had at least the merit of representing that which is the medium of vision, or which forms the communication between the eye and external objects, as something proceeding from the latter. The idea of *simulacra*, or *spectra*, flying off continually from the surfaces of bodies, and entering the eye, was perhaps as near an approach to the true theory of vision as could be made before the structure of the eye was understood.

In the arts connected with optics, the ancients had made some progress. They were sufficiently acquainted with the laws of reflection to construct mirrors both plane and spherical. They made them also conical; and it appears from Plutarch, that the fire of Vesta, when extinguished, was not permitted to be rekindled but by the rays of the sun, which were condensed by a conical speculum of copper. The mirrors with which Archimedes set fire to the Roman galleys have been subjects of much discussion, and the fact was long disbelieved, on the ground of being physically impossible. The experiments of Kircher and Buffon showed that this impossibility was entirely imaginary, and that the effect ascribed to the *specula* of the Greek geometer might be produced without much difficulty. There remains now no doubt of their reality. A passage from Aristophanes² gives reason to believe that, in his time, lenses of glass were used for burning, by col-

¹ The truth of the mathematical proposition, that $\frac{1}{\text{inf.}} = 0$, was perceived by Aristotle. A strong intellect is always visible in the midst of his greatest errors.

² In Nubibus, Act. 2. sc. 1. v. 20.

lecting the rays of the sun ; but in a matter that concerns the history of science, the authority of a comic poet and a satirist would not deserve much attention, if it were not confirmed by more sober testimony. Pliny, speaking of rock crystal, says that a globe or ball of that substance was sometimes used by the physicians for collecting the rays of the sun, in order to perform the operation of cautery. In another passage, he mentions the power of a glass globe filled with water, to produce a strong heat when exposed to the rays of the sun, and expresses his surprise that the water itself should all the while remain quite cold.

With respect to the power of glasses to magnify objects seen through them, or to render such objects more distinct, the ancients appear to have observed ill, and to have reasoned worse. “ *Literæ quamvis minutæ et obscuræ per vitream pilam aqua plenam majores clarioresque cernuntur. Sidera ampliora per nubem adspicienti videntur : quia acies nostra in humido labitur, nec apprehendere quod vult fideliter potest.*”² This passage, and the speculations concerning the rainbow in the same place, when they are considered as containing the opinions of some of the most able and best informed men of antiquity, must be admitted to mark, in a very striking manner, the infancy of the physical sciences.

2. FROM ALHAZEN TO KEPLER.

An interval of nearly a thousand years divided Ptolemy from Alhazen, who, in the history of optical discovery, appears as his immediate successor. This ingenious Arabian lived in the eleventh century, and his merit can be more fairly, and will be more highly appreciated, now that the work of his predecessor has become known. The merit of his book on Optics was always admitted, but he was supposed to have borrowed much from Ptolemy, without acknowledging it; and the prejudices entertained in favour of a Greek author, especially of one who had been for so many years a legislator in science, gave a false impression, both of the genius and the integrity of his modern rival. The work of Alhazen is, nevertheless, in many respects, superior to that of Ptolemy, and in nothing more than in the geometry which it employs. The problem known by his name, to find the point in a spherical speculum, at which a ray coming from one given point shall be reflected to another given point, is very well resolved in his book, though a problem of so much difficulty, that Montucla hazards

¹ Hist. Nat. Lib. 37. cap. 10.

² Seneca, Nat. Quest. Lib. i. cap. 6.

the opinion, that no Arabian geometer was ever equal to the solution of it.¹ It is now certain, however, that the solution, from whatever quarter it came, was not borrowed from Ptolemy, in whose work no mention is made of any such question; and it may very well be doubted, whether, had this problem been proposed to him, the Greek geometer would have appeared to as much advantage as the Arabian.

The account which the latter gives of the augmentation of the diameters of the heavenly bodies near the horizon has been already mentioned. He treated also of the refraction of light by transparent bodies, and particularly of the atmospheric refraction, but not with the precision of Ptolemy, whose optical treatise Delambre seems to think it probable that he had never seen. The anatomical structure of the eye was known to him; concerning the uses of the different parts he had only conjectures to offer; but on seeing single with two eyes, he made this very important remark, that, when corresponding parts of the retina are affected, we perceive but one image.

Prolixity and want of method are the faults of Alhazen. Vitello,² a learned Pole, commented on his works, and has very much improved their method and arrangement in a treatise published in 1270. He has also treated more fully of the subject of refraction, and reduced the results of his experiments into the form of a table exhibiting the angles of refraction corresponding to the angles of incidence, which he had tried in water and glass. It was not, however, till long after this period that the law which connects these angles was discovered. The cause of refraction appeared to him to be the resistance which the rays suffer in passing into the denser medium of water or glass, and one can see in his reasoning an obscure idea of the resolution of forces. He also treats of the rainbow, and remarks, that the altitudes of the sun and bow together always amount to 42 degrees. He next considers the structure of the eye, of which he has given a tolerably accurate description, and proves, as Alhazen had before done,³ that vision is not performed by the emission of rays from the eye.

Roger Bacon, distinguished for pursuing the path of true philosophy in the midst of an

¹ Barrow, in his 9th lecture, says of this Problem, that it may truly be called *δυσμέχανον*, as hardly any one more difficult had then been attempted by geometers. He adds, that, after trying the analysis in many different ways, he had found nothing preferable to the solution of Alhazen, which he therefore gives only freed from the prolixness and obscurity with which the original is chargeable. *Lectioes Opticæ*, Sect. 9. p. 65. A very elegant solution of the same problem is given by Simson, at the end of his Conic Sections.

² The name of this author is commonly written *Vitellio*. He may be supposed to have known best the orthography of his own name.

³ Alhazen, Opt. lib. 1.

age of ignorance and error, belongs to the same period ; and applied to the study of optics with peculiar diligence. It does not appear, however, that he added much to the discoveries of Alhazen and Ptolemy, with whose writings, particularly those of the former, he seems to have been well acquainted. In some things he was much behind the Arabian optician, as he supposed with the ancients that vision is performed by rays emitted from the eye. It must, however, be allowed, that the arguments employed on both sides of this question are so weak and inconclusive, as very much to diminish the merit of being right, and the demerit of being wrong. What is most to the credit of Bacon, is the near approach he appears to have made to the knowledge of lenses, and their use in assisting vision. Alhazen had remarked, that small objects, letters, for instance, viewed through a segment of a glass sphere, were seen magnified, and that it is the larger segment which magnifies the most. The spherical segment was supposed to be laid with its base on the letters, or other minute objects which were to be viewed. Bacon recommends the smaller segment, and observes, that the greater, though it magnify more, places the object farther off than its natural position, while the other brings it nearer. This shows sufficiently, that he knew how to trace the progress of the rays of light through a spherical transparent body, and understood, what was the thing least obvious, how to determine the place of the image. Smith, in his *Optics*, endeavours to show, that these conclusions were purely theoretical, and that Roger Bacon had never made any experiments with such glasses, notwithstanding that he speaks as if he had done so.¹ This severe remark proceeds on some slight inaccuracy in Bacon's description, which, however, does not seem sufficient to authorize so harsh a conclusion. The probability appears rather to be, as Molineux supposed, that Bacon had made experiments with such glasses, and was both practically and theoretically acquainted with their properties. At the same time, it must be acknowledged, that his credulity on many points, and his fondness for the marvellous, which, with every respect for his talents, it is impossible to deny, take something away from the force of his testimony, except when it is very expressly given. However that may be in the present case, it is probable, that the knowledge of the true properties of these glasses, whether it was theoretical or practical, may have had a share in introducing the use of lenses, and in the invention of spectacles, which took place not long after.

It would be desirable to ascertain the exact period of an invention of such singular uti-

¹ Smith's *Optics*, Vol. II. Remarks, § 76.

lity as this last; one that diffuses its advantages so widely, and that contributes so much to the solace and comfort of old age, by protecting the most intellectual of the senses against the general progress of decay. In the obscurity of a dark age, careless about recording discoveries of which it knew not the principle or the value, a few faint traces and imperfect indications serve only to point out certain limits within which the thing sought for is contained. Seeking for the origin of a discovery, is like seeking for the source of a river where innumerable streams have claims to the honour, between which it is impossible to decide, and where the only thing that can be known with certainty is the boundary by which they are all circumscribed. The reader will find the evidence concerning the invention of spectacles very fully discussed in Smith's *Optics*, from which the most probable conclusion is, that the date goes back to the year 1313, and cannot with any certainty be traced farther.¹

The lapse of more than two hundred years brings us down to Maurolycus, and to an age when men of science ceased to be so thinly scattered over the wastes of time. Maurolycus, whose knowledge of the pure mathematics has been already mentioned, was distinguished for his skill in optics. He was acquainted with the crystalline lens, and conceived that its office is to transmit to the optic nerve the *species* of external objects; and in this process he does not consider the retina as any way concerned. This theory, though so imperfect, led him nevertheless to form a right judgment of the defects of short-sighted and long-sighted eyes. In one of his first works, *Theoremata de Lumine et Umbra*, he also gives an accurate solution of a question proposed by Aristotle, viz. why the light of the sun, admitted through a small hole, and received on a plane at a certain distance from it, always illuminates a round space, whatever be the figure of the hole itself, whereas, through a large aperture, the illuminated space has the figure of the aperture. To conceive the reason of this, suppose that the figure of the hole is a triangle; it is plain that at each angle the illuminated space will be terminated by a circular arch of which the centre corresponds to the angular point, and the radius to the angle subtended by the sun's semidiameter. Thus the illuminated space is rounded off at the angles; and when the hole is so small that the size of those roundings bears a large proportion to the distance of their centres, the figure comes near to a circle, and may be to appearance quite round. This is the true solution, and the same with that of Mauro-

¹ Smith's *Optics*, Vol. II. Remarks, § 75.

lycus. The same author appears also to have observed the caustic curve formed by reflection from a concave speculum.

A considerable step in optical discovery was made at this time by Baptista Porta, a Neapolitan, who invented the *Camera Obscura*, about the year 1560, and described it in a work, entitled *Magia Naturalis*. The light was admitted through a small hole in the window-shutter of a dark room, and gave an inverted picture of the objects from which it proceeded, on the opposite wall. A lens was not employed in the first construction of this apparatus, but was afterwards used; and Porta went so far as to consider how the effect might be produced without inversion. He appears to have been a man of great ingenuity; and though much of the *Magia Naturalis* is directed to frivolous objects, it indicates a great familiarity with experiment and observation. It is remarkable, that we find mention made in it of the reflection of cold by a speculum,¹ an experiment which, of late, has drawn so much attention, and has been supposed to be so entirely new. The cold was perceived by making the focus fall on the eye, which, in the absence of the thermometer, was perhaps the best measure of small variations of temperature. Porta's book was extremely popular; and when we find it quickly translated into Italian, French, Spanish, and Arabic, we see how much the love of science was now excited, and what effects the art of printing was now beginning to produce. Baptista Porta was a man of fortune, and his house was so much the resort of the curious and learned at Naples, that it awakened the jealousy with which the court of Rome watched the progress of improvement. How grievous it is to observe the head of the Christian church in that and the succeeding age, like the *Anarch old* in Milton, reigning in the midst of darkness, and complaining of the encroachments which the realm of light was continually making on his ancient empire!

The constitution of the eye, and the functions of the different parts of which it consists, were not yet fully understood. Maurolycus had nearly discovered the secret, and it was but a thin, though, to him, an impenetrable veil, which still concealed one important part of the truth. This veil was drawn aside by the Neapolitan philosopher; but the complete discovery of the truth was left to Kepler, who, to the glory of finding out the true laws of the planetary system, added that of first analyzing the whole scheme of nature in the structure of the eye. He perceived the exact resemblance of this organ to the *dark chamber*, the rays entering the pupil being collected by the crystalline lens, and the other hu-

¹ *Magia Naturalis*, Lib. 17. cap. 4. p. 583. Amsterdam edit. 1664.

mours of the eye, into *foci*, which paint on the *retina* the inverted images of external objects. By another step of the process, to which our analysis can never be expected to extend, the mind perceives the images thus formed, and refers them at the same time to things without.

It seemed a great difficulty, that, though the images be inverted, the objects are seen erect; but when it is considered that each point in the object is seen in the direction of the line in which the light passes from it to the retina, through the centre of the eye, it will appear that the upright position of the object is a necessary consequence of this arrangement.

Kepler's discovery is explained in his *Paralipomena in Vitellionem*¹ (Remarks on the Optics of Vitello), a work of great genius, abounding with new and enlarged views, though mixed occasionally with some unsound and visionary speculations. This book appeared in 1604. In the next article we shall have occasion to return to the consideration of other parts of Kepler's optical discoveries.

3. FROM KEPLER TO THE COMMENCEMENT OF NEWTON'S OPTICAL DISCOVERIES.

The rainbow had, from the earliest times, been an object of interest with those who bestowed attention on optical appearances, but it is much too complicated a phenomenon to be easily explained. In general, however, it was understood to arise from light reflected by the drops of rain falling from a cloud opposite to the sun. The difficulty seemed to be how to account for the colour, which is never produced in white light, such as that of the sun, by mere reflection. Maurolycus advanced a considerable step when he supposed that the light enters the drop, and acquires colour by refraction; but in tracing the course of the ray he was quite bewildered. Others supposed the refraction and the colour to be the effect of one drop, and the reflection of another; so that two refractions and one reflection were employed, but in such a manner as to be still very remote from the truth.

Antonio de Dominis, Archbishop of Spalatro, had the good fortune to fall upon the true explanation. Having placed a bottle of water opposite to the sun, and a little above his eye, he saw a beam of light issue from the under side of the bottle, which acquired different colours, in the same order, and with the same brilliancy as in the rainbow, when the bottle was a little raised or depressed. From comparing all the circumstances, he perceived that the rays had entered the bottle, and that, after two refractions from the convex part, and

¹ Caput 5. de Modo Visionis.

a reflection from the concave, they were returned to the eye tinged with different colours, according to the angle at which the ray had entered. The rays that gave the same colour made the same angle with the surface, and hence all the drops that gave the same colour must be arranged in a circle, the centre of which was the point in the cloud opposite to the sun. This, though not a complete theory of the rainbow, and though it left a great deal to occupy the attention, first of Descartes, and afterwards of Newton, was perfectly just, and carried the explanation as far as the principles then understood allowed it to go. The discovery itself may be considered as an anomaly in science, as it is one of a very refined and subtle nature, made by a man who has given no other indication of much scientific sagacity or acuteness. In many things his writings show great ignorance of principles of optics well known in his own time, so that Boscovich, an excellent judge in such matters, has said of him, "homo opticarum rerum, supra id quod patiatum ea ætas imperitissimus." The book containing this discovery was published in 1611.¹

A discovery of the same period, but somewhat earlier, will always be considered as among the most remarkable in the whole circle of human knowledge. It is the invention of the telescope, the work in which (by following unconsciously the plan of nature in the formation of the eye) man has come the nearest to the construction of a new organ of sense. For this great invention, in its original form, we are indebted to accident, or to the trials of men who had little knowledge of the principles of the science on which they were conferring so great a favour. A series of scientific improvements, continued for more than two hundred years, has continually added to the perfection of this noble instrument, and has almost entitled science to consider the telescope as its own production.

It will readily be believed, that the origin of such an invention has been abundantly inquired into. The result, however, as is usual in such cases, has not been quite satisfactory; and all that is known with certainty is, that the honour belongs to the town of Middleburgh in Zealand, and that the date is between the last ten years of the sixteenth century, and the first ten of the seventeenth. Two different workmen belonging to that town, Zachariah Jans, and John Lapprey, have testimonies in their favour between which it is difficult to decide; the former goes back to 1590, the latter comes down to about 1610. It is not of much consequence to settle the priority in a matter which is purely accidental; yet one would not wish to forget or mistake the names of men whom even

¹ De Radiis Lucis in Vitris perspectivis et Iride.—Venetiis, in 4to.

chance had rendered so great benefactors to science. What we know with certainty is, that the account of the effect produced by this new combination of glasses being carried to Galileo in 1610, led that great philosopher to the construction of the telescope, and to the interesting discoveries already enumerated. By what principle he was guided to the combination, which consists of one convex and one concave lens, he has not explained, and we cannot now exactly ascertain. He had no doubt observed, that a convex lens, such as was common in spectacles, formed images of objects, which were distinctly seen when thrown on a wall or on a screen. He might observe also, that if the image, instead of falling on the screen, were made to fall on the eye, the vision was confused and indistinct. In the trials to remedy this indistinctness, by means of another glass, it would be found that a concave lens succeeded when placed before the eye, the eye itself being also a little more advanced than the screen had been.

This instrument, though very imperfect, compared with those which have been since constructed, gave so much satisfaction, that it remained long without any material improvement. Descartes, whose treatise on Optics was written near thirty years after the invention of the telescope, makes no mention of any but such as is composed of a convex object-glass, and a concave eye-glass. The theory of it, indeed, was given by Kepler in his *Dioptrics* (1611), when he also pointed out the astronomical telescope, or that which is composed of two convex lenses, and inverts the objects. He did not, however, construct a telescope of that kind, which appears to have been first done by *Scheiner*, who has given an account of it in the *Rosa Ursina* (in 1650), quoted by Montucla.¹

After the invention of the telescope, that of the microscope was easy; and it is also to Galileo that we are indebted for this instrument, which discovers an immensity on the one side of man, scarcely less wonderful than that which the telescope discovers on the other. The extension and divisibility of matter are thus rendered to the natural philosopher almost as unlimited as the extension and the divisibility of space are to the geometer.

The theory of the telescope, now become the main object in optical science, required that the law of refraction should, if possible, be accurately ascertained. This had not yet been effected, and Kepler, whose *Dioptrics* was the most perfect treatise on refraction which had yet appeared, had been unable to determine the general principle which connects the angles of incidence and refraction. In the case of glass, he had found by experiment, that those angles, when small, are nearly in the ratio of three to two, and on

¹ Vol. II. p. 234, 2d edit.

this hypothesis he had found the focus of a double convex lens, when the curvature of both sides is equal, to be the centre of curvature of the side turned toward the object,— a proposition which is known to coincide with experiment. From the same approximation, he derived other conclusions, which were found useful in practice, in the cases where the angles just mentioned were very small.

The discovery of the true law of refraction was the work of Snellius, the same mathematician whose labours concerning the figure of the earth were before mentioned. In order to express this law, he supposed a perpendicular to the refracting surface, at the point where the refraction is made, and also another line parallel to this perpendicular at any given distance from it. The refracted ray, as it proceeds, will meet this parallel, and the incident ray is supposed to be produced, till it do so likewise. Now, the general truth which Snellius found to hold, whatever was the position of the incident ray, is, that the segments of the refracted ray and of the incident ray, intercepted by these parallels, had always the same ratio to one another. If either of the *media* were changed, that through which the incident ray, or that through which the refracted ray passed, this ratio would be changed, but while the *media* remained the same, the ratio continued unalterable. It is seldom that a general truth is seen at first under the most simple aspect: this law admits of being more simply expressed, for, in the triangle formed by the two segments of the rays, and by the parallel which they intersect, the said segments have the same ratio with the sines of the opposite angles, that is, with the sines of the angles of incidence and refraction. The law, therefore, comes to this, that, in the refraction of light, by the same medium, the sine of the angle of incidence has to the sine of the angle of refraction always the same ratio. This last simplification did not occur to Snellius; it is the work of Descartes, and was first given in his *Dioptrics*, in 1637, where no mention is made of Snellius, and the law of refraction appears as the discovery of the author. This naturally gave rise to heavy charges against the candour and integrity of the French philosopher. The work of Snellius had never been published, and the author himself was dead; but the proposition just referred to had been communicated to his friends, and had been taught by his countryman, Professor Hortensius, in his lectures. There is no doubt, therefore, that the discovery was first made by Snellius, but whether Descartes derived it from him, or was himself the second discoverer, remains undecided. The question is one of those, where a man's conduct in a particular situation can only be rightly interpreted from his general character and behaviour. If Descartes had been uniformly fair and candid in his intercourse with others, one would have rejected with disdain a suspicion of the kind just mentioned. But the truth is, that he appears through-

out a jealous and suspicious man, always inclined to depress and conceal the merit of others. In speaking of the inventor of the telescope, he has told minutely all that is due to accident, but has passed carefully over all that proceeded from design, and has incurred the reproach of relating the origin of that instrument, without mentioning the name of Galileo. In the same manner, he omits to speak of the discoveries of Kepler, so nearly connected with his own; and in treating of the rainbow, he has made no mention of Antonio de Dominis. It is impossible that all this should not produce an unfavourable impression, and hence it is, that even the warmest admirers of Descartes do not pretend that his conduct toward Snellius can be completely justified.

Descartes would have conceived his philosophy to be disgraced if it had borrowed any general principle from experience, and he therefore derived, or affected to derive, the law of refraction from reasoning or from theory. In this reasoning, there were so many arbitrary suppositions concerning the nature of light, and the action of transparent bodies, that no confidence can be placed in the conclusions deduced from it. It is indeed quite evident, that, independently of experiment, Descartes himself could have put no trust in it, and it is impossible not to feel how much more it would have been for the credit of that philosopher to have fairly confessed that the knowledge of the law was from experiment, and that the business of theory was to deduce from thence some inferences with respect to the constitution of light and of transparent bodies. This I conceive to be the true method of philosophizing, but it is the reverse of that which Descartes pursued on all occasions.

The weakness of his reasoning was perceived and attacked by Fermat, who, at the same time, was not very fortunate in the theory which he proposed to substitute for that of his rival. The latter had laid it down as certain, that light, of which he supposed the velocity infinite, or the propagation instantaneous, meets with less obstruction in dense than in rare bodies, for which reason, it is refracted toward the perpendicular, in passing from the latter into the former. This seemed to Fermat a very improbable supposition, and he conceived the contrary to be true, viz. that light in rare bodies has less obstruction, and moves with greater velocity than in dense bodies. On this supposition, and appealing, not to physical, but to final causes, Fermat imagined to himself that he could deduce the true law of refraction. He conceived it to be a fact that light moves always between two points, so as to go from the one to the other in the least time possible. Hence, in order to pass from a given point in a rarer medium where it moves faster, to a given point in a denser medium where it moves slower, so that the time may be a *minimum*, it must continue longer in the former medium than if it held a rectilineal course, and the bending of its path, on entering the latter, will

therefore be toward the perpendicular. On instituting the calculus, according to his own doctrine of *maxima* and *minima*, Fermat found, to his surprise, that the path of the ray must be such, that the sines of the angles of incidence and refraction have a constant ratio to one another. Thus did these philosophers, setting out from suppositions entirely contrary, and following routes which only agreed in being quite unphilosophical and arbitrary, arrive, by a very unexpected coincidence, at the same conclusion. Fermat could no longer deny the law of refraction, as laid down by Descartes, but he was less than ever disposed to admit the justness of his reasoning.

Descartes proceeded from this to a problem which, though suggested by optical considerations, was purely geometrical, and in which his researches were completely successful. It was well known, that, in the ordinary cases of refraction by spherical and other surfaces, the rays are not collected into one point, but have their foci spread over a certain surface, the sections of which are the curves called caustic curves, and that the focus of opticians is only a point in this surface, where the rays are more condensed, and, of course, the illumination more intense than in other parts of it. It is plain, however, that if refraction is to be employed, either for the purpose of producing light or heat, it would be a great advantage to have all the rays which come from the same point of an object united accurately, after refraction, in the same point of the image. This gave rise to an inquiry into the figure which the superficies, separating two transparent *media* of different refracting powers, must have, in order that all the rays diverging from a given point might, by refraction at the said superficies, be made to converge to another given point.¹ The problem was resolved by Descartes in its full extent; and he proved, that the curves, proper for generating such superficies by their revolution, are all comprehended under one general character, viz. that there are always two given points, from which, if straight lines be drawn to any point in the curve, the one of these, *plus* or *minus*, that which has a given ratio to the other, is equal to a given line.

It is evident, when the given ratio here mentioned is a ratio of equality, that the curve is a conic section, and the two given points its two foci. The curves, in general, are of the fourth or the second order, and have been distinguished by the name of the ovals of Descartes.

From this very ingenious investigation no practical result of advantage in the construction of lenses has been derived. The mechanical difficulties of working a superficies into any figure but a spherical one are so great, that, notwithstanding all the ef-

¹ Cartesii Dioptrices, cap. 8vum; Geometria, lib. 2dus.

forts of Descartes himself, and of many of his followers, they have never been overcome, so that the great improvements in optical instruments have arisen in a quarter entirely different.

Descartes gave also a full explanation of the rainbow, ¹ as far as colour was not concerned, a part of the problem which remained for Newton to resolve. The path of the ray was traced, and the angles of the incident ray, with that which emerges after two refractions and one reflection, was accurately determined. Descartes paid little attention to those who had gone before him, and, as already remarked, never once mentioned the Archbishop of Spalatro. Like Aristotle, he seems to have formed the design of cutting off the memory of all his predecessors, but the invention of printing had made this a far more hopeless undertaking than it was in the days of the Greek philosopher.

After the publication of the *Dioptrics* of Descartes, in 1637, a considerable interval took place, during which optics, and indeed science in general, made but little progress, till the *Optica Promota* of James Gregory, in 1663, seemed to put them again in motion. The author of this work, a profound and inventive geometer, had applied diligently to the study of optics and the improvement of optical instruments. The *Optica Promota* embraced several new inquiries concerning the illumination and distinctness of the images formed in the foci of lenses, and contained an account of the Reflecting Telescope still known by the name of its author. The consideration which suggested this instrument was the imperfection of the images formed by spherical lenses, in consequence of which, they are not in plane, but in curved surfaces. The desire of removing this imperfection led Gregory to substitute reflection for refraction in the construction of telescopes; and by this means, while he was seeking to remedy a small evil, he provided the means of avoiding a much greater one, with which he was not yet acquainted, viz. that which arises from the unequal refrangibility of light. The attention of Newton was about the same time drawn to the same object, but with a perfect knowledge of the defect which he wanted to remove. Gregory thought it necessary that the specula should be of a parabolic figure; and the execution proved so difficult, that the instrument, during his own life, was never brought to any perfection. The specula were afterwards constructed of the ordinary spherical form, and the Gregorian telescope, till the time of Dr Herschel, was more in use than the Newtonian.

Gregory was professor of mathematics at St Andrews, and afterwards for a short time at Edinburgh. His writings strongly mark the imperfect intercourse which subsisted at

¹ Meteorum, cap. 8vum.

that time between this country and the Continent. Though the *Optics* of Descartes had been published twenty-five years, Gregory had not heard of the discovery of the law of refraction, and had found it out only by his own efforts;—happy in being able, by the fertility of his genius, to supply the defects of an insulated and remote situation.

A course of lectures on optics, delivered at Cambridge in 1668, by Dr Barrow, and published in the year following, treated of all the more difficult questions which had occurred in that state of the science, with the acuteness and depth which are found in all the writings of that geometer. This work contains some new views in optics, and a great deal of profound mathematical discussion.

About this time Grimaldi, a learned jesuit, the companion of Riccioli, in his astronomical labours, made known some optical phenomena which had hitherto escaped observation. They respected the action of bodies on light, and when compared with reflection and refraction, might be called, in the language of Bacon's philosophy, *crepuscular* instances, indicating an action of the same kind, but much weaker and less perceptible. Having stretched a hair across a sun-beam, admitted through a hole in the window-shutter of a dark chamber, he was surprised to find the shadow much larger than the natural divergence of the rays could have led him to expect. Other facts of the same kind made known the general law of the *diffraction* or *inflexion* of light, and showed that the rays are acted on by bodies, and turned out of their rectilineal course, even when not in contact, but at a measurable distance from the surfaces or edges of such bodies. Grimaldi gave an account of those facts in a treatise printed at Bologna in 1665.¹

Optics, as indeed all the branches of natural philosophy, have great obligations to Huygens. The former was among the first scientific objects which occupied his mind; and his *Dioptrics*, though a posthumous work, is most of it the composition of his early youth. It is written with great perspicuity and precision, and is said to have been a favourite book with Newton himself. Though beginning from the first elements, it contains a full development of the matters of greatest difficulty in the construction of telescopes, particularly in what concerns the indistinctness arising from the imperfect foci into which rays are united by spherical lenses; and rules are deduced for constructing telescopes, which, though of different sizes, shall have the same degree of distinctness, illumination, &c. Huygens was besides a practical optician; he polished lenses, and constructed telescopes with his own hands, and some of his object-glasses were of the enormous focal distance of 130 feet. To his *Dioptrics* is added a valuable treatise *De Formandis Vitris*.

¹ Physico-Mathesis de Lumine, Coloribus, &c. in 4to.

In the history of optics, particular attention is due to his theory of light, which was first communicated to the Academy of Sciences of Paris, in 1678, and afterwards published, with enlargements, in 1690.¹

Light, according to this ingenious system, consists in certain undulations communicated by luminous bodies to the ethereal fluid which fills all space. This fluid is composed of the most subtle matter, is highly elastic, and the undulations are propagated through it with great velocity in spherical superficies proceeding from a centre. Light, in this view of it, differs from that of the Cartesian system, which is supposed to be without elasticity, and to convey impressions instantaneously, as a staff does from the object it touches to the hand which holds it.

It is not, however, in this general view, that the ingenuity of the theory appears, but in its application to explain the equality of the angles of incidence and reflection; and, most of all, the constant ratio which subsists between the sines of the angles of incidence and of refraction. Few things are to be met with more simple and beautiful than this last application of the theory; but that which is most remarkable of all is, the use made of it to explain the double refraction of Iceland crystal. This crystal, which is no other than the calcareous spar of mineralogists, has not only the property of refracting light in the usual manner of glass, water, and other transparent bodies, but it has also another power of refraction, by which even the rays falling perpendicularly on the surface of the crystal are turned out of their course, so that a double image is formed of all objects seen through these crystals. This property belongs not only to calcareous spar, but, in a greater or less degree, to all substances which are both crystallized and transparent.

The common refraction is explained by Huygens, on the supposition, that the undulations in the luminous fluid are propagated in the form of spherical waves. The double refraction is explained on the supposition, that the undulations of light, in passing through the calcareous spar, assume a spheroidal form; and this hypothesis, though it does not apply with the same simplicity as the former, yet admits of such precision, that a proportion of the axes of the spheroids may be assigned, which will account for the precise quantity of the extraordinary refraction, and for all the phenomena dependent on it, which Huygens had studied with great care, and had reduced to the smallest number of general facts. That these spheroidal undulations actually exist, he would, after all, be a bold theorist who should affirm; but that the supposition of their existence is an accurate expression

¹ Traité de la Lumière. Leyd. 1690.

of the phenomena of double refraction, cannot be doubted. When one enunciates the hypothesis of the spheroidal undulations, he, in fact, expresses in a single sentence all the phenomena of double refraction. The hypothesis is therefore the means of representing these phenomena, and the laws which they obey, to the imagination or the understanding, and there is, perhaps, no theory in optics, and but very few in natural philosophy, of which more can be said. Theory, therefore, in this instance, is merely to be regarded as the expression of a general law, and in that light, I think, it is considered by La Place.

To carry the theory of Huygens farther, and to render it quite satisfactory, a reason ought to be assigned why the undulations of the luminous fluid are spheroidal in the case of crystals, and spherical in all other cases. This would be to render the generalization more complete ; and till that is done, and a connection clearly established between the structure of crystallized bodies, and the property of double refraction, the theory will remain imperfect. The attention which at present is given to this most singular and interesting branch of optics, and the great number of new phenomena observed and classed under the head of the *Polarisation of Light*, make it almost certain that this object will be either speedily accomplished, or that science has here reached one of the immoveable barriers by which the circle of human knowledge is to be for ever circumscribed.

Supplement

TO THE

ENCYCLOPÆDIA BRITANNICA.

A U S T R A L A S I A,

Australasia.

Introductory Observations.

IN Modern Geography, the *fifth* great division of the Earth's surface. A systematic classification in geography is as necessary to enable us to form clear and comprehensive views of its objects, as it is in botany, mineralogy, geology, or any other department of physical science, though incapable of being brought to the same degree of perfection. The rapid progress made, during the last fifty years of the past century, in the discovery of those almost innumerable Islands that are scattered over the three great oceans, the Indian, the Southern, and the Pacific, peopled by various races of human beings, differing in their features, manners, dispositions, and language, forcibly demanded some such systematic arrangement; otherwise, as the President De Brosses has observed, "The sight would be dazzled and confounded, if care were not exerted to relieve it, and fix its attention by divisions marked from distance to distance."

It was this learned and very intelligent writer who first suggested, that all the Lands and Islands in the *Austral* world should be divided into three portions, corresponding with the three great Oceans, the Indian or Ethiopic, the Atlantic, and the Pacific; those in the Indian Ocean, and to the south of Asia, to be named *Australasia*; those in the two Pacifics, from the multitude of Islands, *Polynesia* (a name first used, we believe, by De Barros), and those in the Atlantic, to the south of Cape Horn, and the Cape of Good Hope, *Magellanica*. The last, however, became unnecessary, as soon as it was ascertained, that the *Terra Australis incognita* had no existence. Some idea may be formed of the rapid progress made in

maritime geography, even within the last fifty years, and of its imperfection previous to that period, when it is stated, that, in the year 1770, the enlightened and industrious hydrographer, the late Alexander Dalrymple, asserted that the *great southern continent* was not then a matter of *discovery*, for that it had been seen on the west by Tasman in 1642, and on the east by Juan Fernandez, above half a century before; adding, without any doubt or hesitation, that "the countries intermediate, equal in extent to all the civilized part of Asia, from Turkey to China inclusive, still remain unexplored." Nay, more, "that it extended from 30° south to the pole, and that the number of its inhabitants was probably more than fifty millions." All these facts he discovers in the Spanish and Portuguese voyages in the South Pacific Ocean. (*Historical Collections*.)

The two divisions of Australasia and Polynesia will be found to comprehend, with sufficient convenience, all those Islands, that cannot with propriety be referred to any of the four continents of the Globe. Nor is there any difficulty in drawing the line of separation between those two divisions; though it is not quite so easy to mark the distinct boundary between the Australasian and the Asiatic Islands, where they melt into each other, about the Equator, at the north-west extremity of Papua or New Guinea. In a geographical view, the small Islands of Waygiou, Salwatty, Batanta, Mysol, and Timorlaut, ought strictly to belong to Australasia; but peopled, as they are, by Asiatics of the Malay tribe, and under the influence of the Dutch Islands, it may, perhaps, be more proper, in a moral and political point of view,

Australasia. to consider them as belonging to the Asiatic Islands; more particularly, as we shall then have all the Australasian population, with very few exceptions, marked with the African or Negro character. But, in fact, all geographical divisions are and must be to a certain degree arbitrary.

Boundaries. If, then, we take the equator as the northern boundary from the 132° to the 175° of east longitude; continue a line on the latter meridian to the 55th parallel (bending a little to take in New Zealand) for the eastern; another line along the same parallel to the 65° of east longitude for the southern; and a slanting line to the point on the equator from which we set out, so as to include Kerguelen's land, and pass on the eastern sides of Timorlaut, Ceram, Mysol, and Salwatty, for the western boundary;—those lines will circumscribe the whole of the Australasian Islands. We have included the uninhabited Islands of Kerguelen, and St Paul and Amsterdam, because they cannot properly be considered as African Islands; though arranged, we believe, under that division by Pinkerton: they are of less importance to geography than to geology.

Australasia, then, may be subdivided into the following Groups and Islands:

1. Notasia, or New Holland.
2. Van Dieman's land.
3. Papua, or New Guinea.
4. New Britain, New Ireland, and neighbouring Islands.
5. Solomon's Islands.
6. New Hebrides.
7. New Caledonia.
8. New Zealand, and Isles to the southward.
9. Kerguelen's Islands, or Islands of Desolation.
10. St Paul and Amsterdam.
11. Numerous reefs and Islets of Coral scattered over the Australasian Sea.

New Holland.

I. The first attempt to explore this Island, which, from its size, may be considered as the fifth continent of the earth, is unquestionably due to the Dutch; for, although some part of the northern coast may have been seen by the early navigators of Spain and Portugal, there is no direct testimony in favour of such discovery. There are two charts in the British Museum which belonged to the *Harleian Collection*, one French, without date, which was probably the original, and the other English, apparently a copy; the latter is dedicated to the King of England, and bears date 1542; in both of these charts is marked down an extensive tract of country to the southward

Progress of Discovery.

of the Moluccas, under the name of *Great Java*, agreeing more nearly with the position and extent of New Holland than any other land. The form given to the north-west part of the coast approaches nearest to the truth, a part, indeed, which may have been seen by these early navigators in their return from the Moluccas, long before the date of the English chart. It is a singular coincidence in geographical nomenclature, that on the east coast of the French chart, something like a *Botany Bay* should be designated under the name of *Coste des Herbaiges*. The Abbé Prévost, in the *Histoire Generale des Voyages*, and the President De Brosse, in his *Histoire des Navi-*

gations aux Terres Australes, are not very happy in Australasia. advancing a claim in favour of Paulovier de Gonneville, a French Captain, to the discovery of this *Terra Australis* in 1504. It was the coast of Madagascar upon which Gonneville, as is evident by their own accounts, was driven.

The best and most authentic abstract of the Dutch discoveries, on the coasts of New Holland, is contained in the instructions given by the Governor-General of Batavia to Commodore Abel Janzen Tasman, and published by Mr Dalrymple in his *Collection concerning Papua*. From this document, it appears, that the Dutch government of Bantam, in 1605, dispatched the Duyfhen yacht to explore the Islands of New Guinea. Returning to the southward, along the Islands on the northern side of Torres' Strait, she came to that part of the *Great South Land*, which is now called Cape York; but all these lands were then thought to be connected, and to form the southern coast of New Guinea. "Thus," says Captain Flinders, "without being conscious of it, the commander of the Duyfhen made the first authenticated discovery of any part of the *Great South Land*, about the month of March 1606." About the same place, and in the same year, Torres, a Spanish navigator, being second in command to Fernandez de Quiros, saw the *Terra Australis*, but had as little knowledge of the nature of his discovery as the commander of the Duyfhen. He passed the strait, however, which divides this *Terra Australis* from New Guinea, whose existence was not generally known till 1770, when it was again discovered and passed by our great circumnavigator Captain Cook. Of this, and his other discoveries, Torres addressed an account to the King of Spain; and, as it afterwards appeared, had taken the precaution to lodge a copy of it in the archives of Manilla; for, when that city was surrendered to the British forces in 1762, Mr Dalrymple snatched from oblivion this interesting document of early discovery; and as a just tribute to the enterprising Spanish navigator, he gave to this passage the name of *Torres Strait*, by which it is now universally known.

In 1617 the Dutch sent a second expedition, but "with little success;" the journals of which were lost. In 1623, the yachts *Pera* and *Arnheim* were dispatched from Amboyna, under the command of Jan Carstens, who, with eight of the *Arnheim's* crew, was treacherously murdered by the natives of New Guinea; but the vessels prosecuted the voyage, and discovered the great Islands *Arnheim* and the *Sputl*. The *Arnheim* returned to Amboyna; the *Pera* persisted, and ran along the west coast of New Guinea, as they thought, but it was New Holland, to Cape Keer-veer, or Turn-again, and from thence explored the coast farther southward, as far as 17°, to Staten River. "In this discovery were found everywhere shallow water and barren coasts, Islands altogether thinly peopled by divers cruel, poor, and brutal nations; and of very little use to the (Dutch East India) Company."

The next expedition sent by the Dutch was from Banda in the year 1636, when Gerrit Tomaz Pool proceeded with the yachts *Klein Amaterdam*, and *Wesel*, and nearly at the same place, on the coast of

AUSTRALASIA

Note: The detailed Islands of Ispahan to Lat. 40° 25' Long. 107° 40'; Siam to Lat. 17° 47' Long. 102° 00' and of Amboyna to Lat. 5° 50' Long. 105° 00' are properly being in other editions of the work. They are not included.

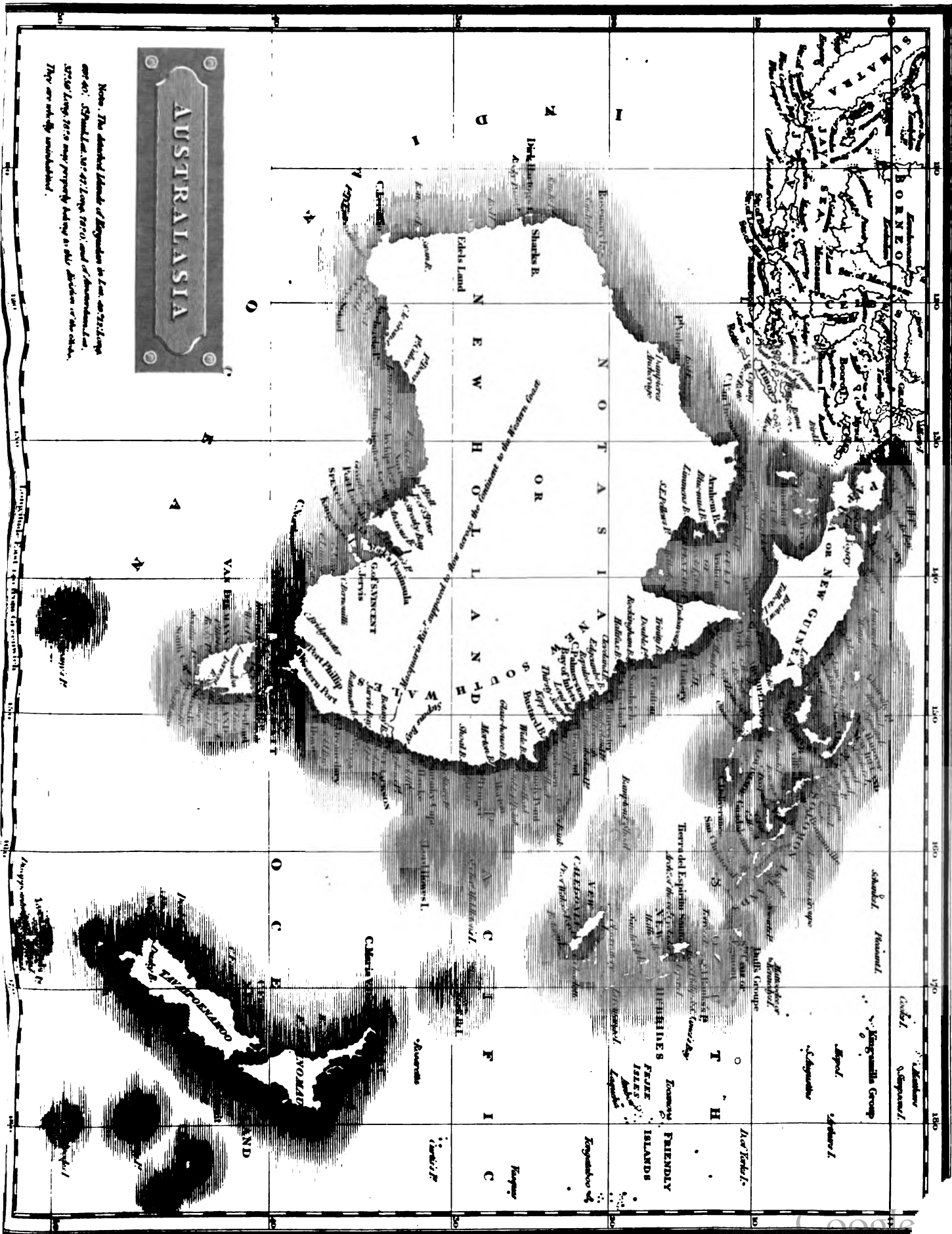

From Mitchell's Part 1st. From the original.

1845

1845

Anstraliasia. New Guinea, met the same fate which had befallen Carstens; but the supercargo, Pieterse, continued the voyage, and discovered the coast of Arnheim, or Van Dieman's land, in 11° south, and sailed along the shore 120 miles, without seeing any inhabitants.

Abel Jansen Tasman sailed on a second voyage of discovery from Batavia in 1644, but no account of this voyage was ever made public, nor is it known to exist. No chart bearing his name is now known, but there is little doubt that the north-west coast of New Holland was first explored by him; and it is singular enough, that Dampier should say he had Tasman's chart of it. Tasman is also supposed to have sailed round the Gulf of Carpentaria, an opinion which Captain Flinders considers to be strengthened, from the names of Tasman, of the governor-general, and of two of the council, who signed his instructions, being applied to places at the head of the gulf, as well as that of Maria, the governor's daughter, to whom Tasman is said to have been attached. Tasman had sailed, on a former voyage, from Batavia in 1642, for the Mauritius; from hence steering south and eastward upon discovery, he fell in with land, to which he gave the name of *Anthony Van Dieman's Land*, in honour of the governor-general, "our master," he adds, "who sent us out to make discoveries."

The last voyage undertaken by the Dutch, for the discovery of *Terra Australis*, was in 1705, when three Dutch vessels were sent from Timor, "with orders to explore the north coast of New Holland better than it had been done before." The account, however, given by the President De Brosse is so vague and imperfect, that very little satisfactory information is to be obtained from it. It is on the west coast that the Dutch appear to have been most successful. In Tasman's instructions it is stated, that "in the years 1616, 1618, 1619, and 1622, the west coast of this great *unknown* southland, from 35° to 22° south latitude, was discovered by outward bound ships, and among them, by the ship *Endragt*." Dirk Hartog commanded this ship, and seems to have made the coast in latitude about $26\frac{1}{2}^{\circ}$ south, and to have sailed northward, along it, to about 23° ; giving the name of *Landt van Endragt* to the coast so discovered; and that of Dirk Hartog's road (called afterwards *Shark's Bay* by Dampier) to an Inlet on the coast, a little to the southward of 25° . A plate of tin was found in 1697, and again seen by Baudin in 1801, on one of the Islands which forms the roadstead, bearing an inscription that the ship *Endragt* of Amsterdam arrived there on the 25th October 1616. After this several outward bound ships fell in, by accident, with different parts of this coast.

The Dutch made little progress in any other part of the extensive coasts of New Holland. The instructions to Tasman say, "In the year 1627, the south coast of the Great South Land was accidentally discovered by the ship the *Guldee Zeepard*, outward bound from Fatherland, for the space of 1000 miles." From the circumstance of this ship having on board Pieter Nuyts, who was sent from Batavia as ambassador to Japan, and afterwards appointed governor of Formosa, the name of *Nuyts' Land* was given to this long range of coast.

Anstraliasia. The first English navigator who appears to have seen any part of New Holland, is the celebrated William Dampier, who, in his buccaneering voyage round the world, in January 1668, touched at the north-west coast, for the purposes of careening his vessel and procuring refreshments. He made the land in latitude $16^{\circ} 15'$, and ran along the shore to the north-east, till he came to a bay or opening fit for the purpose. In 1699, Dampier, a second time, visited the north-western coast of this *Terra Australis*, being now legitimately employed in making discovery, in his Majesty's ship the *Roebuck*. Of this part of the coast little more is yet known than what has been described by Dampier.

It was left for our celebrated navigator, Captain Cook, to complete the grand outline of the fifth continent of the world. The reign of George III. will ever be distinguished for the liberal principles on which voyages of discovery were undertaken, and their results communicated to the world. The Endeavour was fitted out to observe, at Tahiti, the transit of Venus over the sun's disk; on her return, in 1770, Captain, then Lieutenant Cook, explored the whole east coast of the *Terra Australis incognita*, from Cape Howe to Cape York, not minutely entering into the details of every part, which would have been impossible, but laying down a correct general outline. "He reaped," says Captain Flinders, "the harvest of discovery, but the gleanings of the field remained to be gathered." In his passage through Endeavour's Strait, between Cape York and the Prince of Wales' Islands, he not only cleared up the doubt which till then existed, of the actual separation of *Terra Australis* from *New Guinea*, but, by his accurate observations, enabled geographers to assign something like a true place to the former discoveries of the Dutch in these parts.

In 1777 Captain Cook, in the *Resolution* and *Discovery*, visited Van Dieman's Land; but as Captain Furneaux, in his Majesty's ship *Adventure*, had preceded him four years, and Tasman and Marion had examined the coast, little was here supposed to remain for discovery, except in detail. It was long subsequent to Furneaux's visit, that Van Dieman's Land was ascertained to be an Island; a discovery which may have been retarded by that officer having given an opinion, "that there is no strait between New Holland and Van Dieman's Land, but a very deep bay." The existence of such a strait was however still suspected, but the various attempts to ascertain it, without success, by different navigators from both sides of the coast, seemed to have decided the question in the negative, when Mr Bass, surgeon of the *Reliance*, having observed, as he ran down the east coast in an open whale boat, that a heavy swell rolled in from the westward, was satisfied in his own mind that such a swell could proceed only from the great Southern Ocean. To ascertain whether this was the fact, was a point of great importance to the new colony on the eastern coast; and for this purpose Mr Flinders, together with Mr Bass, were sent on this service in a small decked boat;—at the end of three months, they returned to Port Jackson, with an interesting account of the survey of the coasts of Van Dieman's Land, which they had completely cir-

Australasia. cumnavigated, and thus confirmed the conjecture of Mr Bass, whose name the strait deservedly bears.

The French are entitled to the honour of some partial discoveries on *Terra Australis*. Captain Marion was dispatched in the year 1772 from the Isle of France with two ships, the *Mascarin* and *Marquis de Castries*, on a voyage of discovery, one of the objects of which was that of the supposed southern continent. He touched at Van Dieman's Land, quarrelled with the natives, and finding no fresh water, and the weather being stormy, he set sail for New Zealand, having added very little to the prior discoveries of Tasman.

In the year 1792, Rear-Admiral D'Entrecasteaux, having been sent out with two ships, *La Recherche* and *L'Esperance*, in search of the unfortunate La Perouse, made the south coast of New Holland, which he explored as far as the Termination Island of Vancouver, the deficiencies of whose chart he was able to supply, by the state of the weather permitting him to keep the coast closer on board than the English navigator had been able to do. Termination Island was found to be the first of a large group laid down by Nuyts, whose accuracy is praised by the Admiral, he having found "the latitude of Point Leuwen and of the coast of Nuyts' Land laid down with an exactness surprising for the remote period in which they had been discovered." This liberal acknowledgment did not, however, prevent him from giving to the group of Islands, which he only saw, but did not survey, the name of *Archipel de la Recherche*. But the most important discovery of D'Entrecasteaux was an inlet on the south coast of Van Dieman's Land, which was found to be the entrance into a fine navigable channel, running more than thirty miles to the northward, and there communicating with Storm Bay; containing a series of excellent harbours, or rather one continued harbour the whole way, from beginning to end. "The charts," says Captain Flinders, "of the bays, ports, and arms of the sea, at the south-east end of Van Dieman's Land, constructed, in this expedition, by Messieurs Beautemps, Beaupré, and assistants, appear to combine scientific accuracy and minuteness of detail, with an uncommon degree of neatness in the execution. They contain some of the finest specimens of marine surveying, perhaps, ever made in a new country."

In 1800, Captain Baudin was sent out with two armed vessels, *Le Geographe* and *Le Naturaliste*, on a voyage of discovery nominally round the world, but actually, as appears from his instructions, to examine every part of the coasts of New Holland and Van Dieman's Land. The first volume of the account of this voyage was published by M. Peron, one of the naturalists, in 1807; the second never appeared. All the old names of the capes, bays, inlets, and islands, were unblushingly changed to those of Napoleon, his family, his marshals, and members of the Institute; and to 900 leagues of the southern coast, comprehending all the discoveries of Nuyts, Vancouver, D'Entrecasteaux, Flinders, Bass, and Grant, was given the general name of *Terre Napoleon*, while not 50 leagues of real discovery were effected, which had not been anticipat-

ed by Captain Flinders; who, after losing his ship, *Australasia*, and proceeding homewards, was scandalously detained as a prisoner in the Isle of France, "to give time for the previous publication of the voyage of M. Baudin, to prepossess the world, that it was to the French nation only the complete discovery and examination of the south coast of Australia was due."

Captain Flinders, however, ultimately triumphed. After an unjust and cruel captivity of seven years, he arrived in England in 1810, and in 1814 published his discoveries in two volumes, accompanied with an atlas of charts, which may be held forth as models in maritime surveying. At this time, not a single chart of coast, bay, or island, of Captain Baudin's discoveries had appeared, though shortly afterwards, an atlas was published by Freycinet, the first lieutenant, differing in their form and structure very little from those of Captain Flinders, but bearing the names recorded in M. Peron's first volume. The frontispiece to this atlas affords an instance of that almost impious adulation which Buonaparte was in the habit of receiving from his slaves. An eye, having an N within it, darts its rays through a dark cloud overshadowing a Globe with the southern pole uppermost, on which is drawn the outline of New Holland, with this inscription, "*Fulget et ipso.*"

It is to Captain Flinders that we owe the completion in detail of the survey of the coasts of New Holland, with the exception of the west and north-west coasts, which he was prevented from accomplishing by the loss of his ship. Dampier had said, in anchoring near the south end of De Witt's Land, behind Rosemary Island, which was one of an extensive cluster, "by the tides I met with a while afterwards, I had a strong suspicion that there might be a kind of archipelago of Islands, and a passage possibly to the south of New Holland and New Guinea, into the Great South Sea eastward;" but whether it might be a channel or strait, or the mouth of a large river, he seems not to have made up his mind. Vlaming saw an opening 12 miles wide near the same place, and could find no anchorage. It has now been ascertained, that there is no outlet into the great Ocean eastward, nor into the gulf of Carpentaria, nor into Bass Strait; but the geographical problem yet remains to be solved, whether the opening in the coast behind Rosemary Island be not the mouth of a large river. *Le Geographe* and *Le Naturaliste*, under Baudin, stood along this coast, examined in a very slovenly manner some particular points, but assisted geography less than they perplexed it, by unwarrantably changing every old name for that of some of the upstarts created by the French revolution. Never, indeed, were two naval officers so ill selected for the purpose of discovery as Captains Baudin and Hamelin; not so those in the scientific department, who, under every unfavourable and discouraging circumstance, effected more for physical science than could be expected. The whole of this coast then may still be considered as *terra incognita*; and it is somewhat remarkable, that the local government of New South Wales, which, we believe, has under its command several colonial vessels, should not before this have taken occasion to ascertain this

Australasia. point, on which so many curious and unexplained phenomena in the geography and geology of the fifth continent depend. It is no less remarkable, that in a period not far short of thirty years since the settlement of Port Jackson was first made, all beyond as many leagues was a complete *terra incognita* to the settlers, till about two years ago, when Mr Evans, the land-surveyor, penetrated behind the hitherto impassable barrier, the Blue Mountains, to the distance of about 300 miles in two separate journeys.

Journeys in the Interior. Of these journeys we are enabled to give a brief abstract.

On the 19th November 1813, Mr Evans left Emu Island in the Nepean, and returned on the 8th January 1814, having performed a journey of 154 miles nearly west. At the end of 48 miles, he had cleared the ranges of mountains, which he says are granite, with loose flints and quartz pebbles strewed on the surface; and here, for the first time, he fell in with a small stream running to the westward. The farther he advanced the more beautiful the country became; both hill and dale were clothed with fine grass, the whole appearing at a little distance as if laid out into fields divided by hedge-rows; through every valley meandered trickling streams of fine water, all falling down towards the *Fish River*, so called by him from the vast abundance of fine fish resembling trout, which his party caught with ease whenever they had occasion for them. Many of the hills were capped with forest trees, chiefly of the Eucalyptus, and clumps of these mixed with Mimosas and the Casuarina, were interspersed along the feet of the hills and in the valleys, so as to wear the appearance of a succession of gentlemen's parks. The river, which at first consisted of a chain of pools, connected by small streamlets, had assumed in the neighbourhood of *Macquarrie's Plains*, the character of a considerable stream, and had become unfordable, which made it necessary to construct a bridge of large trees to transport the people, the horses, and baggage. Evans says, the country was now more beautiful than he had ever seen. A fine river, running in a deep channel over a gravelly bottom, and its banks skirted with trees, excepting at the sloping points of hills round which it winded, and which were covered with a fine green sod down to the margin, intermixed with the white daisy;—all this, added to the temperate climate, put him in mind of England. Farther on, and before they reached *Bathurst's Plains*, the river was increased considerably in size by the junction of another stream, which he called *Campbell's River*; and to the united streams, he gave the name of *Macquarrie's River*, the general direction of which appeared to be to the northward of west. Fish continued to abound of the same kind as those first caught, but of a size from 11 to 15 pounds each. Governor Macquarrie says, these fish resemble perch, are not unlike that usually called rock-cod, and have been caught from 17 to 25 pounds weight each. Large herds of emus were seen crossing the plains, and kangaroos in great abundance; but not a native human being appeared until on his return, when, near *Bathurst's Plains*, two women and four children were come upon by surprise, and were so terrified, that they fell down with fright. It was observed, that both the women had

lost the right eye. Evans makes *Bathurst's Plains* near 150 miles from Emu Island; but Governor Macquarrie, who subsequently visited this place, states the measured distance from Sydney town to be only 140 miles. It is represented as an eligible situation for establishing a settlement, as the land is excellent; plenty of stone and timber for building, but no limestone; abundance of water, though the river, at the time of the Governor's visit, just at the close of an unusually dry season, was reduced to a chain of pools, the intermediate channels being dried up.

From hence Mr. Evans was a second time dispatched, in May 1815, to follow the course of *Macquarrie's River*. He proceeded about 115 miles, from whence he could see across an extensive plain, 40 or 50 miles, at the extremity of which was a range of blue mountains, separated by an opening in the north-west, through which, he had no doubt, the river flowed; and he appears to have as little doubt, that it crosses the continent, and falls into the sea, somewhere in *De Witt's Land*, probably through *Dampier's Opening*, behind *Rosemary Island*.

From these journeys, it appears clear that the country is but thinly peopled. The natives that were seen resembled, in their persons and features, those of Sydney, but spoke a different language; and they were better clothed, being well covered with kangaroo skins, sewed neatly together with the sinews of emus. They wore the fur side next the skin, and the outer or flesh side was very ingeniously marked with regular ornamental devices, among which the *cross* appeared to predominate. They were exceedingly terrified at the sight of Mr Evans on his horse, as they took the rider and horse to be one animal, and did not recover from their fright or surprise on seeing him dismount. When a little tranquillized, and more familiar, they were found to be a good-humoured laughing people, exhibiting none of that savage and furious spirit of the natives of Sydney. They were attended with dogs not unlike the jack-all, with which they catch kangaroos. The spears they carried were heavy, and clumsily made, and they could only throw them to a short distance, something like the *New Zealanders*.

The country beyond *Bathurst* was even superior to that first explored. The vast herds of emus and kangaroos were truly astonishing. These animals, and the fish of the river, appeared to be the principal articles of subsistence for the natives. In one large plain, covered with kangaroos and emus, Evans discovered an immense quantity of a white substance, resembling comfits or sugar-plums, which he took to be manna, but which appears to be a pure saccharine substance,—an exudation probably from some particular plant. He passed whole mountains of fine blue limestone, and picked up topazes, crystals, and other pebbles, such as are met with on the coast of *Bass's Strait*. He also mentions forests of pines, the trees 40 feet high without a branch. Governor Macquarrie, however, observed, that as the soil and grass-lands improved, the timber trees decreased in size. (See the different works of *Dalrymple*, *Burney*, *Cook*, *D'Entrecasteaux*, and *Flinders*.)

If, however, but little is yet known of the interior

Australasia of New Holland, and the detail of the western coast still requires to be filled up, the grand outline of this large Island, or, more properly, Continent, has been completed, and its limits correctly ascertained. It extends in latitude from Cape York in $10^{\circ} 45'$ south to Wilson's promontory in $39^{\circ} 9'$ south, and in longitude from Dirk Hartog's Island in Shark's Bay in 113° east, to point Look-out in Glasshouse Bay in $153^{\circ} 35'$ east; the mean breadth, from north to south, being about 1200, and length, from east to west, 2100 geographical miles, making an area equal to about three-fourths of the Continent of Europe. A remarkable sameness in all the productions of the three kingdoms of nature prevails in every part of its extensive coasts, and as remarkable a difference in two of them (the animal and vegetable) from those of the rest of the world.

Natives.

The natives, wherever they have been met with, are of the very lowest description of human beings. In the journal of the Duyfhen, the north coast is described as thinly "inhabited by wild, cruel, black savages, by whom some of the crew were murdered;" and the ship Vianen, touching on the western coast about 21° south, observed "a foul and barren shore, green fields, and very wild, black, barbarous inhabitants." In 24° south, Polsert, who commanded the Batavia, saw four natives, whom he describes as "wild, black, and altogether naked, not covering even those parts which almost all savages conceal." Tasman "found in *Hollandia Nova*, in lat. $17^{\circ} 12'$ south, a naked black people, with curly hair, malicious, and cruel, using for arms bows and arrows, hazagaeyns and kalawaeyns." Dampier describes them as being "a naked black people, with curly hair, having a piece of the rind of a tree tied like a girdle about their waists, and a handful of long grass, or three or four green boughs full of leaves thrust under their girdle to cover their nakedness;" that "the two fore-teeth of the upper jaw are wanting in all of them, men and women, old and young; neither have they any beards." And he remarks, "they have no boats, canoes, or bark-logs." The south coast is so barren, and the naked hillocks of sand so continuous, that there appears to be nothing for human inhabitants to subsist upon. "It is not surprising," says D'Entrecasteaux, "that Nuyts has given no details of this barren coast; for its aspect is so uniform, that the most fruitful imagination could find nothing to say of it." Even where the country begins to improve towards the eastward, in the neighbourhood of Kangaroo Island, Captain Flinders found not the least vestige of inhabitants; and, from the stupidity of the kangaroos on that Island, "which," he observes, "not unfrequently appeared to consider us as seals," he concludes there either are no natives, or that they are ignorant of every kind of embarkation. Towards the northern part of the eastern coast, the same navigator thinks they are somewhat superior to those near Sydney, having belts round the waist, and fillets about the head and upper part of the arm, associating in greater numbers, and dwelling in huts of a superior construction. They also catch fish with nets, which he thinks is alone a feature of distinction from those who only spear the fish, as a net requires

more than one person to manage, consumes much time in making, cannot easily be dragged about, and, in short, must occasion a sense of the advantage to be derived from mutual assistance, and suggest the necessity of a permanent residence. The native of the colony of Sydney we know pretty well to be a gloomy, solitary, unsettled being; seldom appearing, even in the town, without his spear, his throwing-stick, or his club. "His spear," says Colonel Collins, "is his defence against enemies. It is the weapon he uses to punish aggression, and revenge insult. It is even the instrument with which he corrects his wife in the last extreme; for, in their passion, or perhaps oftener in a fit of jealousy, they scruple not to inflict death. It is the plaything of children, and in the hands of persons of all ages." Turnbull says, the natives of this part of New Holland are, beyond comparison, the most barbarous on the surface of the Globe, and that the influence of European settlers has had no effect in rendering them more sensible of the benefits of civilization; that every day men and women are to be seen in the streets of Sydney and Paramatta naked as in the moment of their birth; yet he contends that they are far from being stupid; that they are the greatest mimics alive; and that the oddities, dress, walk, gait, and looks of all the Europeans of any rank, from the time of Governor Phillip downwards, are so exactly imitated, as to form among them a kind of historic register of their several actions and characters; and they are great proficient in the slang language of the convicts. But this seems to be the sum total of all their acquisitions from European intercourse. In all other respects they remain the same untutored, unprotected, improvident, and comfortless savages we first found them. By all who have seen them they are described as hideously ugly, with flat noses, wide nostrils, eyes sunk in the head, overshadowed with thick black eyebrows; the mouth extravagantly wide, lips thick and prominent, hair black and clotted, but not woolly, the colour of the skin varying from dark bronze to jet black. Their stature is below the middle size. They are remarkably thin and ill made, their limbs small, and almost without any appearance of muscle. They live chiefly on fish, which they sometimes spear and sometimes net, the women on parts of the coast aiding to catch them with the hook and line. If a dead whale happens to be cast on shore, numbers flock to it from every part of the coast, just as the vultures smell out a dead carcase, and they feast sumptuously while any part of it remains. Those in the interior are stated to live on grubs, ants and their eggs, kangaroos, when they can catch them, fern roots, various kinds of berries, and honey. These sylvan satyrs are described as having long and lean legs and arms, owing, as is supposed, to their climbing of trees, which they ascend by notches cut into them by stone hatchets, in which the great toe is placed, and by these means they ascend trees that are 70 or 80 feet high.

To add to their natural deformity, they thrust a bone through the cartilage of the nose, and stick with gum to their hair, matted with moss, the teeth of men, sharks, or kangaroos, the tails of dogs, jaw-bones of fish, &c. and daub their faces and bodies

Australasia. with red and white clay, and scarify the skin in every part with sharp shells. The women and female children are generally found to want the first two joints of the little finger of the left hand; and the reason they assign is, that they would otherwise be in the way of winding the fishing-lines over the hand.

They have no fixed habitations, the climate generally allowing of their sleeping in the open air, in the crevices of rocks, or under the shelter of the bushes. Their temporary hovels consist of the bark of a tree, each hovel just large enough to receive a single person; to the northward, on the east coast, some were discovered a little larger, so that a family might, on an emergency, squeeze under one of them; but they are without furniture or conveniences of any description. They seem to have no idea of the benefits arising from social life; their largest clans extend not beyond the family circle, of each of which the eldest is called by a name synonymous with that of *father*. They are totally without religion, neither paying the least respect or adoration to any object or being, real or imaginary. Hence they have nothing to prompt them to a good action, nothing to deter them from a bad one; hence murder is not considered as any heinous crime, and women think nothing of destroying, by compression, the infant in the womb, to avoid the trouble, if brought alive into the world, of carrying it about and finding it subsistence. Should a woman die with an infant at the breast, the living child is inhumanly thrown into the same hole with the mother, and covered with stones, of which the brutal father throws the first. They are savage even in love, the very first act of courtship, on the part of the husband, being that of knocking down his intended bride with a club, and dragging her away from her friends, bleeding and senseless, to the woods; the consequence is, that scarcely a female of the age of maturity is to be seen without her head full of scars, the unequivocal marks of her husband's affection. The nearest relations are also perpetually destroying each other, either by stratagem or open combat; for, savage as they are, they have a singular custom of expiating an offence, even murder, by the criminal exposing himself to as many of the injured family as may choose to stand forth and hurl their spears at him. From the moment that he is so dreadfully mangled that he can stand no longer, or has the good fortune to parry all their shafts, a reconciliation takes place, and friendship is restored; if the criminal refuses to stand this trial, he and all his family are considered as fair game to attack and murder wherever they are met with. The English used to attend these unequal combats, and thus gave countenance to a savage practice, which not infrequently ended in the death of the person who was put on his defence. (See *Collins, Flinders, Turnbull, &c.*)

Animals. If no very essential difference be perceptible in the moral and physical qualities of the man of New Holland, and the rest of the species, except that which arises from the different circumstances under which they are placed;—if the rocks and mountains, and the earths, resemble nearly the inorganic substances that are met with in other parts of the world,

Australasia. there is at least a very extraordinary, and a distinct characteristic difference in both the animal and vegetable part of the creation, which makes a considerable class of subjects in both these kingdoms peculiar to New Holland. The quadrupeds hitherto discovered, with very few exceptions, are of the kangaroo or opossum tribe; having their hinder legs long out of all proportion, when compared with the length of the fore legs, and a sack under the belly of the female for the reception of the young, of which family, though divided into different genera, there are at least fifty distinct species. They have rats, and dogs of the jackall kind, all exactly alike, and a little animal of the bear tribe named *womat*, and these pretty nearly complete the catalogue of four-footed animals yet known on this fifth Continent. There appears, indeed, such an apparent affinity of the natural objects in New South Wales, that Dr White observes, all the quadrupeds are like opossums, all the fish like sharks, and that every part of the land, all the trees, and all the grasses, resemble one another. There is, however, an animal which resembles nothing in the creation but itself,—which, being rejected by naturalists from the classes mammalia, aves, and pisces, must, we suppose, be considered as belonging to the amphibia,—we mean the *Ornithoryncus paradoxus*, “a quadruped with the beak of a bird, which is contrary to known facts and received opinions.” When the head of one of these beasts was brought to the late Dr Shaw, of the British Museum, he suspected it as an idle attempt to impose on his judgment, and did not hastily believe that nature had set the bill of a duck on the head of a quadruped; but so it has since proved to be the case.

The birds are no less singular than the beasts, there being black swans and white eagles; the former everywhere in such multitudes as to spoil a proverb that had held good for two thousand years; and their song, if we may credit Mr Bass, “exactly resembles the creaking of a rusty sign on a windy day.” The *Mænura superba*, with its scalloped tail feathers, is perhaps the most singular and beautiful of that very elegant race of birds known by the name of *birds of paradise*; cockatoos, parrots, and parroquets, are innumerable, and of great variety. The mountain eagle is a magnificent creature, but the emu is perhaps the tallest and loftiest bird that exists, many of them standing full seven feet high.

The plants are no less singular than the animals. **Plants.** Of these Mr Brown has given a very curious and instructive account in his *Geographical and Systematical Remarks*, in the *Appendix to Flinders's Voyage*. He collected nearly 3900 species of Australasian plants, which, with those brought to England by Sir Joseph Banks and others, supplied him with the materials for a *Flora Terræ Australis*, consisting of 4200 species, referable to 120 natural orders: but he remarks, that more than half the number of species belong to eleven only of those orders. Of the *Eucalyptus*, or gum-tree, the largest yet discovered, there are not fewer than 100 different species. “The *Eucalyptus globulus* of Labillardiere,” says Mr Brown, “and another species, peculiar to the south of Van Dieman's Land, not unfrequently attain the

Australasia. height of 150 feet, with a girth near the base of from 25 to 40 feet." Of this magnificent genus there are 50 different species within the limits of the colony of Port Jackson. Of the beautiful and elegant *Melaleuca* Mr Brown collected upwards of 30 species; all of which, with the exception of the two species the *Leucodendron* and *Cajaputi*, appear to be confined to Terra Australis. The tribe of *Stackhousea* is entirely peculiar to that country. Of the natural order of *proteaceae*, consisting of about 400 known species, more than 200 are natives of New Holland, of which they form one of its characteristic botanical features; the *Banksia*, in particular, being one of the most striking peculiarities of the vegetable kingdom. The *Casuarina*, of which 13 species have been discovered, is another characteristic feature of the woods and thickets of New Holland. The most extensive genus, however, is the leafless *Acacia*, of which there are more than 100 species; and this, with the *Eucalyptus*, "if taken together," says Mr Brown, "and considered with respect to the mass of vegetable matter they contain, calculated from the size as well as from the number of individuals, are perhaps nearly equal to all the other plants of that country." The *Casuarina* and the *Eucalyptus* are represented as furnishing excellent timber for ship-building, and for all the purposes of domestic furniture, and agricultural implements; and the gum of the *Eucalyptus* is medicinal; of one species it might be employed as pitch. Freycinet says, they procured a resinous substance from the *Xanthorrhoea*, which served them to caulk their vessels. The bark of a tree on the Hawkesbury is said to be as efficacious in tanning leather as the oak-bark; and a creeping plant (*smilax*) is used as a substitute for tea. Nutmegs were found by Flinders on the northern coast, but they were small, and had so little of an aromatic flavour, that Mr Brown gave the plant the specific name of *insipida*. Among the curious productions of the vegetable world is the *Cephalotus follicularis*, or pitcher plant, of which a very correct and detailed drawing is given in the Atlas to Flinders's *Voyage*. (For an account of the history of the British Colony in New Holland, see NEW HOLLAND in the *Encyclopaedia*; and BOTANY BAY, in this Supplement, for an account of its present state.)

Van Dieman's Land. II. Having marked the progressive discovery of this fair and fertile Island, until it was ascertained to be such, by Tasman, Marion, Furneaux, Cook, D'Entrecasteaux, Bass, and Flinders; we shall not think it necessary to notice the minor discoveries of Bligh, Hunter, Cox, &c. but proceed to give a general outline of its dimensions, surface, and natural productions. It is situated between the parallels of 41° and 43° 32' south latitude, and 144° 32' and 148° 25' east longitude; its medial length, from north to south, being about 160, and breadth, from east to west, 145 geographical miles. Its surface possesses every variety of mountain, hill, and dale; of forests and open meadows; of inland lakes, rivers, and inlets of the sea, forming safe and commodious harbours, that can render a country valuable or agreeable; and it enjoys a temperate climate, which is, perhaps, not very different from that of England, though

General View of this Country.

less subject to violent changes. In May, corresponding to our November, Labillardiere observed the mountains in the interior covered with snow. The western and southern coasts are bold, steep, and rocky, the latter terminating so abruptly, as to appear as if it had been broken off: and the group of Islands, named De Witt's Isles, to the southward, twelve in number, formed out of the fragments. Cook found the cliffs on the eastern side composed of sandstone; but the vast buttresses that look towards the southern seas of ice, are stated by Flinders to be composed of basaltic columns, appearing like so many stacks of chimneys. Labillardiere found, near this southern extremity, a stratum of coal 3½ feet thick, and 200 fathoms long, resting on sandstone.

The soil in general is represented as more productive than that of the east side of New Holland; and the Island has the advantage of being intersected by two fine rivers, rising near the centre: the one named the Tamar, falling into Bass's Strait on the north, and forming Port Dalrymple; the other, the Derwent, which discharges itself into the sea on the south-east extremity; spreading its waters, in the first instance, over the Great Storm Bay, which communicates with North Bay, Norfolk Bay, and Double Bay, on the east; and with D'Entrecasteaux's Channel on the west. The Tamar, in its course, receives three streams,—the North Esk, the South Esk, and the Lake river; and the tide flows about 30 miles up the river, to the point where it is joined by the two Esk. At the head of the western arm of Port Dalrymple, is situated York town, on the skirt of a beautiful, rich, and well wooded country. There is also a town, named Hobart town, on the right bank of the Derwent, about five miles inland. The country between these two towns was traversed by Mr Grimes in 1807, who describes it to be everywhere rich and beautiful, abounding in grassy plains, marshes, and lakes, bounded on each side by hills, well clothed with wood, rising into high and rocky mountains.

The description given by D'Entrecasteaux of the channel that bears his name, and the surrounding shores, is grand and imposing, and corresponds generally with the following animated account of it from M. Peron, ten years afterwards. "Crowded on the surface of the soil are seen on every side those beautiful *Mimosas*, those superb *Metrosideros*, those *Correas*, unknown till of late to our country, but now become the pride of our shrubberies. From the shores of the ocean to the summits of the highest mountains, may be observed the mighty *Eucalyptus*, those giant trees of Australasian forests, many of which measure from 162 to 180 feet in height, and from 25 to 30, and even 36 feet in circumference. *Banksia*, of different species, the *Protea*, the *Embothria*, the *Leptosperma*, form an enchanting belt round the skirts of the forests. Here the *Casuarina* exhibits its beautiful form: there the elegant *Exocarpus* throws into a hundred different places its negligent branches. Everywhere spring up the most delightful thickets of *Melaleuca*, *Thesium*, *Conchylum*, *Evodia*, all equally interesting, either from their graceful shape, the lovely verdure of their foliage, the singularity of their corollas, or the form of their seed-vessels." (*Voy. aux Terres Aust.*)

Australasia.
Natives.

All the navigators who have visited the southern part of Van Dieman's Land, describe the natives as a mild, affable, good-humoured, and inoffensive people, with the exception of Marion, the effect of whose fire-arms, Labillardiere thinks, had made them afraid of Europeans. Flinders and Bass conceived, that the natives of this Island were sunk still lower in the scale of human existence than those in the neighbourhood of Port Jackson, though they saw but one man, and he is described as having "a countenance more expressive of benignity and intelligence than of that ferocity or stupidity which generally characterized the other natives." They are obviously the same people as those of New Holland, and go entirely naked, both men and women; but their language is altogether different; they have the art, too, of striking fire with two flints, which is not known to the other Australasian islanders; and it is also singular, that they set no value on iron. The women refused from Cook's people all presents, and rejected all their addresses, not so much from a sense of virtue, it was supposed, as from the fear of the men, of whom they stood in great awe. In some places were found miserable huts of twigs, and rude baskets, made of a juncus, or rush; but these were all the signs that appeared of civilization. Cook, D'Entrecasteaux, and Baudin, all observed many of the largest trees, with trunks hollowed out, apparently by means of fire; and, as the hollow side invariably faced the east and south-east, the lee-side to the prevailing winds, it was concluded they were intended as habitations. In D'Entrecasteaux's Channel only were indications of huts made of the bark of the *Eucalyptus*, consisting of three rolls stitched together. (*D'Entrecasteaux, Labillardiere, Flinders, &c.*)

Papua or
New
Guinea.

Progress of
Discovery.

III. This great Island is, after New Holland, not only the first in point of magnitude, but claims a priority in discovery over that and every other Island in the Australasian Sea. In the year 1526, when the Portuguese and the Spaniards were disputing their respective claims to the Spice Islands, Don Jorge de Meneses, of the former nation, had, in his passage from Malacca to the Moluccas, by extraordinary and accidental circumstances, discovered the north coast of Papua, so called, according to some, because the word signifies *black*, which was the colour of the natives, or *curled hair*, according to others. Meneses remained at a port called Versija, till the change of the monsoon, and then returned to the Moluccas. The next navigator who touched at Papua was Alvarez de Saavedra, on his homeward voyage from the Moluccas, in 1528, for New Spain; and from an idea that the country abounded in gold, he gave to it the name of *Isla del Oro*. From the resemblance of the natives to African Negroes, being black, with short curly hair, the name was afterwards changed by the Spaniards to New Guinea, and not, as some have supposed, because it was thought that Guinea and Papua were situated under the same parallel of latitude; which, however, they certainly are, though one happens to be north and the other south latitude. He staid a month, and obtained provisions, but some Portuguese deserted with the only boat the ship had, and were left behind. They found their way, how-

ever, to Gilolo, and reported that Saavedra had been wrecked; but on his subsequent arrival they were tried, condemned, and executed. He is supposed to have added about 50 leagues of discovery to that of Meneses. In 1529, Saavedra sailed a second time for New Spain, and, according to Galvaom (or Galvano), followed the coast of Papua eastwards above 500 leagues.

In 1537, Gonzalva and Alvarado were dispatched on discovery by the Viceroy of Peru; but the former being killed in a mutiny, the crew chose another commander; and the first land they made was Papua. The ship was in so crazy a state, that she was abandoned; the crew, only seven in number (the rest having died of hunger and fatigue), were made captives, and carried to an Island called *Crespos* (curly haired men), from whence they were sent to the Moluccas and ransomed.

In 1545, Ynigo Ortiz de Retz, in his voyage from Tidore to New Spain, came to an Archipelago of Islands near the land of Papua; sailed 230 leagues along the north coast; and not knowing it had been before visited by Europeans, he called it *Nueva Guinea*, from the resemblance of the natives to those of the coast of Guinea.

In 1606, Torres made the east coast of New Guinea, in his way to the Moluccas, sailed westward 300 leagues, doubled the south-east point, sailed along the southern coast, saw the northern coast of New Holland, and passed the Strait which now bears his name. He describes the coast of New Guinea to be inhabited by a dark people, naked, except a covering round the middle of painted cloth made of the bark of a tree. They had arms of clubs and darts ornamented with feathers. He fell in with many large islands, large ports, and large rivers. Towards the northern extremity he met with Mahomedans, who had swords and fire-arms.

In 1616, Schouten came in sight of a burning mountain on the coast of New Guinea, which he named Vulcan, and immediately after of the coast itself. The Island was well inhabited, and abounded with cocoa nuts, but no anchoring ground could be found; the natives black, with short hair, but others appeared of a more tawny colour, with canoes of a different shape. Among the Islands in sight to the northward, four small ones continually smoked. On approaching the mainland, the natives, whom he calls real Papoos, came off, "a wild, strange, and ridiculous people, active as monkeys, having black curled hair, rings in their ears and noses, and necklaces of hog's tusks." They had all some personal defect; one was blind, another had a great leg, a third a swelled arm, which made Schouten conclude that this part of the country was unhealthy, in which he was more confirmed by observing their houses built upon stakes eight or nine feet from the ground. At the two little Islands of Moa and Insou, on the north-east coast, the friendly natives supplied them with abundance of cocoa nuts. At 28 leagues from Moa, Schouten fell in with a group of fourteen small Islands covered with wood, but apparently uninhabited; but sailing to the northward, they were followed by six large canoes, the people in them armed with javelins. Those in some canoes from

Anstralasia. another Island were of a tawny complexion, had long curly hair, and appeared, by their persons and language, to be a different race from the natives of Papua; they had rings of coloured glass, yellow beads, and vessels of porcelain, which were regarded as "evidences of their having communication with the East Indies." Schouten's Island is the largest of this group. Tasman visited all these islands, and the coast of New Guinea, in 1643, and obtained vast numbers of cocoa nuts and bananas from the friendly natives of Moa and Insou. Tasman made no discoveries in this part of his voyage.

Our countryman Dampier saw the coast in 1699, but did not land; the natives came off to his ship, and he speaks in admiration of their large and picturesque proas. He discovered, however, a Strait unknown before, which divides New Guinea from New Britain, and is now called after his name. Bougainville was less fortunate, when, in 1768, he touched on the coast of what he considered to be a separate island, and to which he gave the name of Louisiade; there is, however, some reason to believe that it is a continuation of New Guinea. D'Entrecasteaux, in 1792, passed along the northern coast of Louisiade, and through Dampier's Strait, but left the point of its identity with, or separation from, New Guinea undecided.

Sonnerat published "*A Voyage to New Guinea.*" though he evidently never was there, but describes the natives and productions from what he saw, and what he could collect at the island of Gibby, to the eastward of Gillolo.

Forrest, in 1775, anchored in the Bay of Dory, on the northern extremity of New Guinea, and collected some information respecting the inhabitants from a Mahomedan Hadji, who accompanied him. Captain Cook, also, in his first voyage in 1770, made the coast in about 6½° south latitude, a little to the northward of Cape Valscher, but did not bring his ship to anchor, on account of the hostility of the natives. A party landed near a grove of cocoa-nut trees, and not far from it found plantain, and the bread-fruit tree. The breeze from the trees and shrubs is said to have been charged with a fragrance not unlike that of gum *benjamin*. Three Indians rushed out of the wood with a hideous shout, ran towards the party, the foremost throwing something out of his hand which burnt like gunpowder, the other two hurling their lances at the same time. Before they reached the pinnacle, from sixty to a hundred had collected, all stark naked; their appearance as to stature, colour, and crisped hair, resembling that of the New Hollanders. They let off fires by four or five at a time, but for what purpose could not be imagined. These fires appeared to be discharged from a piece of stick, probably a hollow cane; and the fire and smoke exactly resembled those of a musket, but without any report. Those who were on board ship, at a distance, concluded they had fire-arms, and even those in the boat might have supposed them firing volleys, had they not been so near as to ascertain that there was no report. Torres had observed something of the same kind, in about 4° south latitude on the same coast, where, he says, the inhabitants were black, but better cloth-

ed than those southward; that among the weapons **Anstralasia.** used by them were hollow bamboo sticks, which they filled with lime, and by throwing it out, endeavoured to blind their enemies: this explanation, however, does not account for the *fire*. Forrest says, that the Chinese, from Tidore, trade with Papua, under Dutch colours; perhaps, therefore, gunpowder may be one of the articles carried by them in exchange for the slaves, ambergrease, sea-slugs (*biche de mer*), tortoise-shell, loories, birds of paradise, &c. which they carry back to China.

If we suppose the Louisiade of Bougainville to be connected with New Guinea, this Island extends in a south-east by east direction from the Cape, absurdly called Good Hope, nearly under the equator, to Cape Deliverance, in 11½° south, being in length about 1400, and medial breadth about 150 geographical miles. The accounts of all the navigators who have touched on the different parts of its coast, describe it as a rich and magnificent country, containing, in all human probability, from its situation and appearance, all the valuable vegetable products of the Moluccas and the several Asiatic Islands. Forrest found the nutmeg-tree on Manaswary Island in the Bay of Dory; and he learned that a people in the interior, called *Haraforas*, cultivate the ground, and bring their produce down to the sea-coast; that they are very poor, and some of them have long hair, and that they live in trees, which they ascend by cutting notches in them. The people of New Guinea, in many parts of the coast, live in huts, or cabins placed on stages that are erected on poles, commonly in the water; probably as a protection against snakes and other venomous creatures; though Forrest seems to think against the *Haraforas*. On these stages they haul up their proas or canoes. These people are invariably described as being hideously ugly; their large eyes, flat noses, thick lips, woolly hair, and black shining skin, denote almost to a certainty their African origin, and their affinity with the natives of New Holland; but the difference of language, and the want of all the useful productions on the latter, which abound on New Guinea, induced Captain Cook to conclude, that there is no intercourse between the two people. The Papuans increase their natural deformity by passing bones or pieces of stick through the cartilage of the nose, and frizzing out their curly locks like a mop, sometimes to the enormous circumference of three feet. They appear, however, to be one degree farther removed from savage life than the New Hollanders, having permanent houses, and both men and women wearing wrappers round the waist, which are among the articles brought to them by the Chinese and Malays.

The only quadrupeds that are known to exist on this large Island are dogs, rats, and wild hogs; but the feathered race are of great beauty and infinite variety. New Guinea is the native country of those singular and matchless beauties, the *birds of paradise*, which were once thought to have no legs, but always on the wing, and known by the name of *passaros da sol*, birds of the sun. They are said to migrate in large flocks, in the dry Monsoon, to the Islands of Arroo, and other Islands to the west and north-west of New Guinea. The great crown pigeon, parrots, loories, and minas, are natives of Papua.

Australasia. The whole of this great country is indented with deep bays on every side, some of which nearly intersect the Island; and the coast is surrounded on every side with a multitude of small Islands, all peopled with the same description of Blacks, excepting those already mentioned on the north-west, near the equator, most of which are under the government of Mahometan Malays, with whom both the Dutch and Chinese have long kept up a considerable intercourse.

thick cocoa-nut groves skirted all the low parts of the coast. Labillardiere says that New Ireland produces nutmegs, and he also mentions a new species of the Areca palm, 108 feet high, the stem consisting of hard solid timber.

New Britain, New Ireland, and neighbouring Islands.

Discovery.

IV. There can be little doubt that this extensive range of Islands was partially seen by Le Maire and Schouten in 1616, who, after discovering the Groene Island and the Marquen Islands, steered along the northern coast of New Ireland, as did Tasman also in 1642. Dampier, however, first ascertained New Britain to be an Island distinct from New Guinea, by passing the strait which since has borne his name. He visited Port Montague on this Island, and speaks of the black natives resembling the Papuans, their dexterity in managing their canoes, their woody hills, fertile vales, and delightful rivulets. He also anchored in Slinger's Bay on New Ireland, which he conceived to be the same land with New Britain; but Carteret, in 1727, discovered and passed through a strait which separates them, and to which he gave the name of St George's Channel. The Admiralty Islands of Carteret, to the north-westward of New Britain, had previously been discovered by Schouten, and named the *Twenty-five Islands*. New Britain was seen by Roggewein in 1722, and by Bougainville in 1768.

The natives of the Admiralty Islands, lying to the north-west, were found by Carteret to be less black than those of New Britain and Ireland, with agreeable countenances, not unlike Europeans; their hair was curly, smeared with oil and red ochre, and their bodies and faces painted with the same material; the glans penis was covered with the shell called the *Bulla ovium*, serving the same purpose as the wooden sheath of the Caffres in South Africa, whom, indeed, they seem to resemble as closely as the natives of New Guinea do those of the western coast of Africa. The women wear a bandage round the waist. The central Island is tolerably large, and of a beautiful appearance, clothed with the most luxuriant verdure, and cultivated to the very summit. Among the groves of cocoa-nut trees are numerous habitations, and the natives have evidently attained to a higher degree of civilization than their southern neighbours; they use earthen vessels, and chew the betel leaf with chunam or lime. This central Island is surrounded by nearly thirty small flat Islets of coral, and reefs in the various stages of their progress towards Islets.

General Description.

D'Entrecasteaux, we believe, was the last navigator who passed along the north coast of New Britain, and through St George's Channel, which divides it from New Ireland, and from thence to the Admiralty Islands; and from his voyage, published by Rossel, together with Labillardiere and Carteret's, we shall extract a few gleanings.

Proceeding to the westward, and to the north-west, we meet with other little clusters of Islands,—as the Hermites, the Portland, the Echequier (chess-board), vulgarly called *Exchequer Islands*, all of which consist, like the Admiralty Archipelago, of a larger central Island surrounded by a chain of Islets and reefs, most of them covered with beautiful verdure. The natives of these groups, as they approach the equator, gradually assume a lighter colour and longer hair, till they lose entirely the negro character, and melt into that of Malays, and other Asiatic Islanders. (See *Schouten, Dampier, Carteret, Labillardiere, &c.*)

Natives.

The extent of New Britain and Ireland is not exactly known, nor have they been sufficiently explored to enable geographers to lay them down with accuracy, or even to state what number of Islands the group consists of: one of considerable extent lies off the north-west end of New Ireland, which has been named New Hanover, and is itself surrounded by low woody Islands. The whole group occupies a space between $2\frac{1}{2}^{\circ}$ and 6° of south latitude, and 149° and 153° of east longitude, and may probably contain an area not less than 10,000 geographical miles.

V. This archipelago of Islands was one of the first ^{Solomon's} discoveries of the Spaniards in Australasia, though ^{Islands.} the credit of it is given to Alonso de Mendana, who was sent on an expedition of discovery in 1567 from Callao by the Viceroy of Peru. He anchored in a ^{Discovery.} port on the Island of Santa Ysabel, to which he gave the name of Porta de la Estrella, and he also built a brigantine to make farther discoveries, in which she was particularly successful, having fallen in with thirty-three Islands in number, "of very fine prospect." Many of them were of considerable size, to which they gave particular names, as *Galera, Buonavista, Florida, San German, Guadalcanar, San Christoval, Santa Catarina, and Santa Ana*. Guadalcanar, however, was the most attractive, having a port which they named *De la Cruz*, and a river which they called *Galego*. Of this Island Mendana took possession for the King of Spain. When the voyage was published, the name of Solomon's Islands was given to the group, "to the end that the Spaniards, supposing them to be those Isles from whence Solomon fetched gold to adorn the temple at Jerusalem, might be the more desirous to go and inhabit

Australasia. the same," but it has been said that Mendana's advice was, that they should not be colonized, "that the English, or others, who pass the Strait of Magellanes to go to the Moluccas, might have no succour there, but such as they get from the Indians." The truth, however, is, that Mendana, on a second voyage for the discovery of the Solomon Islands, returned without being able to find them, which gave occasion to the remark, that, "what Mendana discovered in his first voyage, he lost in his second." He discovered, however, in this second voyage, the great Island of Santa Cruz, which is situated at the south-east extremity of Solomon's Islands, and may very fairly be considered as one of the group. This Island, which has an excellent harbour, *La Graciosa*, was first revisited by Carteret, in 1767, after Mendana's discovery, who changed its name to that of Egmont, and made it the principal Island of a group which he called Queen Charlotte's Islands. Here Mendana died, and Quiros succeeded to the command; but the search for Solomon's Islands was abandoned when they were not more than 40 leagues from Christoval. It is a singular fact, that Solomon's Islands, whose name was sufficient to tempt adventurers, were lost to Europeans for two centuries after their discovery, and that we know at present little, if any, more than Mendana gave to the world after his first voyage. They were revisited by Bougainville in 1768; by M. Surville in 1769, on a voyage from Pondicherry of mercantile speculation, and who, from a ridiculous mistake, called them the Archipelago of the *Arsacides*, to mark the natives as *assassins*; and by Lieutenant Shortland, of the British navy, in 1788, who chose to call them New Georgia; and frequently since that time by various British and French navigators;—still the little we know of them is from Mendana.

Natives. Santa Ysabel, he says, was inhabited by people who had the complexion of mulattos, with curly hair, with little covering to their bodies, who worshipped serpents, toads, and such like creatures; their food cocoa-nuts and roots; and it was believed that they eat human flesh, "for the chief sent to the general a present of a quarter of a boy with the hand and arm." Buonavista is twelve leagues in extent, very fertile, well peopled, the natives living in regular villages or towns. On Florida, twenty-five leagues in circuit, the natives dyed their hair red, collected together at the sound of conch-shells, and eat human flesh. Sesarga was well inhabited, produced plenty of yams and bread-fruit, and here the Spaniards saw hogs. In the midst of the Island was a volcano, continually emitting smoke. They saw bats which measured five feet between the tips of the wings. At Guadalcanar they received in barter two hens and a cock, the first fowls that had been seen. At San Christoval, the natives were very numerous, and drew up to give battle to the Spaniards, their arms being darts, clubs, bows and arrows; but they were dispersed by the fire of the muskets, which killed one Indian, and wounded others. In the neighbouring village was found a quantity of cocoa-nuts and almonds, sufficient to have loaded a ship. Santa Ana was well peopled

and fertile. It has a good port on the east side, Australasia. where the Spaniards were attacked by the natives, who wounded three of the invaders, and one dart pierced through the target and arm of the Spanish commanding officer; the blacks had boughs on their heads, and bands round their waists. The Spaniards observed here hogs and fowls.

VI. To the south-east of Solomon's Islands, and between the parallels of $14\frac{1}{2}^{\circ}$ and 20° south latitude, are found a number of Islands, some of very considerable magnitude, called the *New Hebrides*, or *Hebudes*. They were first discovered in 1606, by Pedro Fernandez de Quiros, who, with Luis Vaez de Torres, was sent by the King of Spain from Lima, with two ships and a zabra (launch) to establish a settlement at the Island Santa Cruz, and from thence to go in quest of the *Tierra Austral*, or southern continent. This voyage has been considered, and justly so, among the most celebrated undertaken by the Spaniards since the time of Magellanes. In April 1606, they discovered an Island, to which they gave the name of *Santa Maria*, from whence they saw another Island to the southward, "so large," says Torres, "that we sailed for it." On the 2d May; they anchored in a bay, large enough to hold a thousand ships, to which they gave the appropriate name of *San Felipe y Santiago*. Quiros at once determined that he had now discovered the long-sought-for southern continent, and in this conviction named it the *Australia del Espiritu Santo*. Two rivers fell into the bay, one the Jordan, the other the Salvador. The surrounding country was beautiful, and is thus described by the historian of the voyage: "The banks of the rivers were covered with odoriferous flowers and plants, particularly orange flowers and sweet basil, the perfumes of which were wafted to the ships by the morning and evening breezes; and, at the early dawn was heard, from the neighbouring woods, the mixed melody of many different kinds of birds, some in appearance like nightingales, blackbirds, larks, and goldfinches. All the parts of the country in front of the sea were beautifully varied with fertile valleys, plains, winding rivers, and groves, which extend to the sides of green mountains." (*Torquemada*, as quoted in Burney's *Account of Discoveries in the South Sea*.)

Of this terrestrial paradise, which the Spaniards regarded as their own, it was intended to take immediate possession; they landed in great numbers; the Islanders were also numerous, became alarmed, made them presents, and signified a wish for them to return to their ships. They, however, landed from their boats, on which the chief drew a line on the ground with the end of his bow, and made signs that the Spaniards must not pass that boundary. It is said that Torres, to show his contempt of the idea of being restrained by barbarians, immediately passed the line. A battle ensued, in which the chief was killed, and all the rest fled into the woods. This rash act, however, was fatal to the views of the Spaniards, who never afterwards could prevail on the Islanders to have any friendly communication with them; and they left this country, after some ridicu-

Australasia. lous formalities of taking possession in the name of Philip III. and founding a city, dignified with the name of the *New Jerusalem*.

So anxious was Quiros of "adding the *Australia del Espiritu Santo* to the other possessions of the Spanish monarchy," that, after his return to Spain, he is said to have presented no less than fifty memorials to the King. One of these, which was printed at Seville, begins thus: "I, Captain Pedro Fernandez de Quiros, say, that, with this I have presented to your Majesty eight memorials relative to the settlement which ought to be made in *Australia Incognita*." In these memorials, he enumerates the many valuable productions of this supposed southern continent: cocoa-nuts, plantains, sugar-canes, yams, batatas, oranges, limes, papas, pumpkins, almonds, nutmegs, mace, ginger, and pepper, in great quantities; woods for "building any number of ships." The animals are hogs, goats, and dogs; fowls, and a variety of useful and beautiful birds; various good fish; and pearl oysters. The climate is described as so fine, and such a freshness in the air, that neither by labour, exposure to the sun, or rain, or dews, nor by intemperance, did any of the Spaniards fall sick; and among the natives many aged people were seen. They wear a covering round the middle: Torres says they are all black and naked. They are described by Quiros as corpulent and strong, cleanly, cheerful, sensible, and grateful; their houses stood on the ground, and not on poles, built of wood, and thatched. They weave nets, and make earthen vessels, have plantations inclosed with palisades, construct vessels which navigate to distant countries, and have places appropriated for burying the dead; and, he adds, as the last and decisive test of their progress in civilization, "they cut their hogs and make capons."

Description.

This archipelago of Islands, like that of Solomon, was lost to the world for a century and a half, when Bougainville revisited them in 1768; but, except landing on the Isle of Lepers, did nothing more than discover that the land was not connected, but composed of Islands, which he called the *Great Cyclades*; which, on being more accurately and extensively explored by Cook, in 1774, underwent another change to that of New Hebrides, which they now bear in all our charts. According to the survey of our great navigator, they consist of *Tierra del Espiritu Santo*, the largest of the whole, *St Bartholomew*, *Mallicola*, *the Isle of Lepers*, *Aurora*, *Whitsuntide*, *Ambrym*, *Apee*, *Paoom*, *Three-hills*, *Sandwich*, *Montagu*, *Hinchinbrook*, *Shepherd's Isles*, *Erromango*, *Tanna*, and *Immer*, *Annatom*, and *Erronan*. The two which are more particularly described, are Mallicolo and Tanna, the natives of which differ remarkably in their persons and language; those of the latter having curly but long hair, dark but not black, and without anything of the negro character in their features, which are regular and agreeable; their persons slender, active, and nimble. They found them hospitable, civil, and good-natured; but displayed a jealousy of their visitors seeing the interior of the Island, which could only be equalled in Japan or China. All the plantations were fenced, and laid out in a line: they consisted of sugar-canes, yams, plan-

Natives.

Australasia. tains, bread-fruit, &c. The yams remarkably fine, one of which weighed fifty-six pounds, every ounce of which was good; and they had pigs and poultry. The juice of the cocoa-nut, and water, appeared to be their only beverage. Their arms were clubs, darts, lances, and bows and arrows. Their canoes, clumsily sewed together, had outriggers, and were worked by paddles and by sails. The men wore a wrapper round the loins, and the women a sort of petticoat reaching to the knee.

The natives of Mallicolo are called by Captain Cook "an ape-like nation;" the most ugly, ill-proportioned people he ever met with, and different from all others; diminutive in their persons, dark-coloured, with black hair, short and curly, but not so woolly as a negro's: they had long heads, flat faces, and monkey countenances; and a belt round the waist, pulled tight across the belly, made them look not unlike overgrown pismires. The women were equally ugly; the dress of both, in other respects, the same as that of Tanna, as were also the productions of the Island. Their houses were low, and covered with palm thatch. (See *Dabrymple*, *Burney*, *Cook*, &c.)

VII. This large Island, surrounded with coral islets **New Cal-** and reefs, was wholly unknown till Captain Cook, in **donia.** 1774, fell in with the north-western extremity in steering south-west from Mallicolo, from which it is distant not more than about 80 leagues. He anchored within a small Island called Balabea, and opposite to the district Belade. The great Island extends between latitude 20° 5' and 22° 30' in the direction **Descrip-** of north-west and south-east; about 250 miles long **tion.** by 60 broad. The land bears a great resemblance to that of New South Wales, and many of its natural productions appeared to be the same, but the natives were different. They are represented as a strong, robust, active, well-made people, courteous and friendly, and not in the least addicted to pilfering, in which respect they differ from every other tribe of Australasia. They are nearly of the same **Natives.** colour as the natives of Tanna, and appeared to be a mixed race between that people and those of the Friendly Isles, or of Tanna and New Zealand; their language being a mixture of them all. Of the same disposition as the natives of the Friendly Islands, they were found to excel them in affability and honesty; and the women, like those of Tanna, were more chaste than the females of the more eastern Islands, not one of the ship's company having been able to obtain the least favour from any one of them. They wear a petticoat of the filaments of the plantain tree, "at least six or eight inches thick, but not one inch longer than necessary for the use designed." They paint and puncture their bodies, and wear earrings, and necklaces, and bracelets, of tortoise and other shells. Both men and women have good features and agreeable countenances, and some of the men measured in height six feet four inches. Their hair is frizzled out like a mop, is very black, coarse, and strong, different from that of a negro. The ruff mop-heads make use of "scratchers," composed of a number of sticks of hard wood, about the thickness of knitting-needles, fastened together at one

Australasia. end like a sort of comb; the women have their hair cropped short. The men wear a wrapper round the loins, made of the bark of a tree. Their houses resemble bee-hives, with peaked roofs, entered by a hole just big enough to admit a man bent double. The sides are of spars and reeds, and both these and the roof well thatched with dry grass. They boil their roots and fish in earthen jars. They have nets made of plantain fibres, and the sails of their canoes are of the same material. These vessels consist of two trees fixed together by a platform. They have plantations of sugar-canes, plantains, bread-fruit, and cocoa-nut, but none of them very productive. The whole appearance of the country, indeed, is described as unable to support many inhabitants. The greater part of the visible surface consists of barren rocky mountains; and though the plains and valleys appeared to be fertile, Captain Cook was of opinion that "nature has been less bountiful to it than to any other tropical Island we know in this sea."

D'Entrecasteaux passed the opposite extremity of New Caledonia in 1792, when on his search after the unfortunate La Pérouse, but was prevented by a barrier reef of coral from approaching the coast; and, in the following year, he visited Balade on the north-west. The account of the inhabitants, as given by Rossel and Labillardiere, differs altogether from that of Cook. Instead of finding them friendly, honest, and inoffensive, they are described as the worst of cannibals; not only eating the flesh of their enemies, but feeding on little children; ferocious in their dispositions, the most audacious thieves, and the women the most shameless prostitutes. But their own account of their transactions there, the confidence with which they straggled over the country, and the readiness of the savages to serve them, by no means warrant the bad character they have thought fit to give them; and they had no more proof of their being cannibals, than they had for accusing the people of Van Dieman's Land of the same practices, because the Surgeon Major mistook the bone of a kangaroo for that of a young girl. They appear to have endeavoured, by signs, to extort a confession to this effect from the poor savages, who, on their part, were also persuaded that the French were the real cannibals. The charge brought against the women is grounded solely on two young girls having been prevailed on by some of the crew to expose what decency requires to be concealed, in return for some pieces of cloth or iron. Labillardiere thinks the inhabitants, as well as the vegetable productions, resemble those of Van Dieman's Land. There was no want of different kinds of esculent plants, though a great scarcity prevailed from drought, or other cause, when they arrived. The young shoots of the *Hybiscus tiliaceus*, the fruit of the *Cordia sebestina*, the *Dolichos tuberosus*, *Helianthus tuberosus*, *Arum esculentum*, and *Macrorrhizon*, *Hyporhis*, *Aleurites*, figs, oranges, plantains, sugar-canes, cocoa-nuts, and the bread-fruit,—all afforded them articles of food. Yet Labillardiere says they eat steatite, and that he saw one man devour a piece of this stone as large as his two fists. They also eat a species of spider. They had lost the hogs which Cook left them, but some half

dozen of cocks and hens were seen by the French. Australasia. (See Cook, Labillardiere, &c.)

VIII. Though these Islands geographically belong to New Zealand, the natives are, in their physical character and language, Polynesians. They were first discovered on the 13th December 1642, by Abel Jansen Tasman, on his voyage of discovery from the Mauritius; and, on the 18th, the Heemskirk yacht, and the fly-boat Zeehaan, came to anchor in a bay to which they afterwards gave the name of Moordeenaar's or Murderer's Bay, and to the Island that of *Staaten Land*, in honour of the States General, and in the possibility that it might join the Staaten Land to the east of the Tierra del Fuego. "It is a fine country," says Tasman, "and we hope it is part of the *unknown South Continent*." The expedition of Hendrik Brower to Chili the following year, cut off the latter Staaten Land from any continental connection, and the name of the former was then changed to that of *New Zealand*.

On the 19th, a boat with 13 natives came within a stone's throw of the Heemskirk. The language in which they hailed was unlike that of the Solomon's Islands, of which Tasman had a vocabulary. Their vessel consisted of two narrow canoes, joined together by boards, on which the people sat; their paddles, about a fathom long, pointed at the end; their clothing appeared of mats or cotton, but their breasts were naked. They invited them to come on board, but in vain. The ships, however, were moved nearer in shore, upon which seven double vessels came off. A boat, being dispatched from one ship to the other, was previously attacked. Three men belonging to the Zeehaan were killed, and one mortally wounded; one of the killed was dragged into the canoes. After this, despairing of getting water or provisions, they weighed and set sail; twenty-two of the native boats following them, eleven of which were full of people. The ships fired, and the canoes returned to the shore.

The next visitor, at the distant period of 127 years, was Captain Surville, who, in 1769, put into a bay on the north-eastern extremity, and gave it the name of Lauriston Bay. In the same year, Lieutenant (afterwards Captain) Cook, of the Endeavour, made the land on the 6th October 1769, the enormous height of which became the subject of much conversation; and the general opinion was, that they had now discovered the *Terra Australis incognita*. This voyage, however, and the circumnavigation of the Islands of New Zealand, entirely subverted the theory of a great southern continent. In 1772, Captains Marion du Fresne and Crozet put into the Bay of Isles, where the former, and some of the crew, were murdered by the natives. In March 1773, Captain Cook in the Resolution, with Captain Furneaux in the Adventure, revisited New Zealand, where the latter had a whole boat's crew, with a midshipman, murdered by the inhabitants. In 1776 and 1777, a third visit was made to these Islands by Captain Cook. In these several visits, accompanied as he was with men well versed in every branch of natural knowledge, there will be found in the *Voyages* of Cook and Forster every species of information that

Australasia. the ferocious disposition of the inhabitants made it practicable to collect.

**Descrip-
tion.** The two great Islands of New Zealand extend between latitude 34° and 48° south, longitude 181° and 194° east; that to the northward called Eaheinomawe, is about 400 G. miles long by 90 medial breadth; the name of the southern Island is Tavaipoenammoo, is about 450 G. miles long by 95 broad; the former has a rich and fertile soil, well clothed with trees, some of them more than 20 feet in girt, and 90 feet high, without a branch. Some of them resembled spruce, and were "large enough for the mainmast of a 50 gun ship." The highest hills were covered with forests, the valleys with grass and shrubbery, and the plains were well irrigated with rills of clear water. The southern Island is very mountainous; one peak, resembling that of Teneriffe, was estimated by Forster, but without sufficient data, at 14,000 feet of height; it was covered with snow in the middle of January. Both as to appearance and temperature, they may be considered as the British Isles of Australasia. Fahrenheit's thermometer in February was never higher than 66°, and was not lower in June than 48°.

A great part of the western side of those Islands had, however, a desolate and inhospitable appearance; exhibiting ranges of yellow sandstone, or white sand hills, with scarcely a blade of verdure. It is worthy of remark, that this extraordinary difference prevails between the two coasts of South Africa, the two coasts of New Holland, and the two coasts of Van Dieman's Land.

Natives.

The natives are stout, well limbed, and muscular, vigorous and active, excelling in manual dexterity; their countenances intelligent and expressive, of an olive complexion, but not darker than a Spaniard. In the appearance of the women, there is not much feminine delicacy; but on Cook's first visit, they found them more modest and decent in their behaviour, than in any of the islanders they had met with; they were covered from the shoulders to the ankles with a sort of netted cloth, made of the split leaves of the flax plant (*Phormium tenax*), the ends hanging down like fringe. A party once came upon some women by surprise, as they were fishing, naked, for lobsters, and "the chaste Diana, with her nymphs, could not have discovered more confusion and distress at the sight of Actæon, than these women expressed upon our approach." On the third visit, however, they had got rid of all their modesty, and a rusty nail was sufficient to purchase the last favour.

The black hair of the men is bound in a knot on the top of the head; that of the women is cropped; both sexes anoint their hair with rancid oil, and smear their bodies with grease and red ochre. The faces of the old men are covered with large furrowed black marks, generally spiral lines, and have a horrible appearance. The women wear in their ears pieces of cloth, feathers, sticks, bones, &c. and bracelets and anklets of bone, teeth, shells, &c. Captain Cook did not observe any appearance of disease, or bodily complaint, or eruption on the skin, or marks of any; and the most severe wounds healed most rapidly. Very old men, without hair or teeth,

showed no signs of decrepitude, and were full of cheerfulness and vivacity. They are mild, gentle, and affectionate towards each other, but ferocious and implacable towards their enemies; and it unfortunately happens, that the little societies into which they appear to be divided, are in an almost perpetual state of hostility, which makes it necessary for them to dwell in happahs or villages, fortified with embankments, ditches, and pallisadoes. They give no quarter, and feast with apparent relish on the bodies of their enemies, which they cut up and broil in holes dug in the earth; they suck out the brains, and preserve the skulls as trophies. They made no hesitation in devouring human flesh in presence of the English officers, and their provision baskets had generally the head or a limb of a human subject.

The only quadrupeds on the Islands are dogs, small and ugly, and rats, the former of which they eat, and with their skins, cut into strips, they adorn their clothing; but their principal food consists of fish, and the bruised roots of fern. They cultivate, however, and with great neatness, sweet potatoes, eddas, and gourds, all planted in regular rows; and Cook observed, near the villages, both privies and dunghills. Their houses have a ridge-pole to the roof, which, with the sides, are built of sticks and grass, and lined with bark; they sleep on the floors covered with straw; and the furniture consists of a chest to hold their tools, clothes, arms, and feathers, provision baskets, and gourds to hold water, which is their only beverage; the New Zealanders being among the very few people, civilized or savage, who are ignorant of the means of intoxication.

Their double canoes, or whale boats, are admirably constructed with planks from 60 to 70 feet in length, and their prows and sterns are tastefully and curiously carved and ornamented, all of which is performed by adzes and axes of a hard black stone, or green talc or jade, and with chisels of human bone or jasper. Of these materials also are their offensive weapons made: these are lances fourteen feet long, sharp at both ends, of hard wood, neatly carved; and a battle axe of jade or bone about a foot long. Their war canoes carry from 60 to 70 men each; they keep exact time with their paddles, singing, with great vociferation and distorted features, their savage war song, when bound on any hostile expedition. Their war dances are conducted in the same furious and extravagant style; the only musical instrument, if it can be called one, is a triton shell, which sounds like a cow's horn.

They have, however, a taste for music, and the women are said to sing in a soft, slow, and mournful cadence, making use of semitones. When their husbands are slain in battle, they cut their legs, arms, and faces, with bone or sharp shells, and few of them that do not wear scars on their bodies as testimonials of their affection and sorrow for their deceased friends.

The natives of New Zealand exhibit a strange mixture of civilized and savage life. It was hoped from the state of their cultivated grounds, of which several hundred acres were seen, that presents of hogs, kids, and poultry, would have been most acceptable, and considerable numbers were left with them

Australasia. on the first and second visits of Captain Cook; but, excepting the cocks and hens, which had bred plentifully, and flew about wild in the woods, the others had been wantonly destroyed. In 1791, Vancouver touched at Dusky Bay, and remained there for some time, examining the bays and creeks in the neighbourhood; but they did not see one human being. And, in 1793, D'Entrecasteaux passed between the Three King's Island, and Cape Maria Van Dieman, but had no other communication with the natives but in their canoes. Unlike in every respect to the Otaheitans, they have evidently a common origin; their language not differing more than the language of the two New Zealand Islands from each other. The few notions they have of superior beings also accord with those of Otaheite. (See *Cook's Voyages.*)

A missionary of the name of Marsden, from merely seeing some New Zealanders in New South Wales, had the hardihood to accuse Captain Cook of having drawn "a false picture of the New Zealanders." He undoubtedly thought so, and went to the Islands with a view of converting the natives to Christianity. He soon, however, abandoned this "noble race of men," as he calls them, being unable, by his own account, "to lay the first stone;" consoling himself for his disappointment by the reflection that "the pious Israelites could not build the walls of Jerusalem without holding the sword in one hand and the trowel in the other." Captain Cook's accuracy is too well established to be shaken by such authority. The following horrible transaction proves how well he described the character of these cannibals. In December 1809, the ship *Boyd*, from Port Jackson, was at Wang-arrooa, in the Bay of Islands, and admitted, without due caution, too large a number of natives on board, when the crew were suddenly attacked, overpowered, and slaughtered. Captain Alexander Berry of the ship *Edinburgh Castle*, being on the coast, was soon after apprised of this horrible event; and, proceeding to the bay, found the remains of the *Boyd*, which had been burned by the savages. On landing, he discovered that the massacre had been directed by Tippahee, the old chief, who had been so much caressed at Sydney. The bones of the unfortunate men lay scattered on the ground, where their bodies had been devoured by the savages. Sixteen were murdered and cut up on the deck of the vessel; five others, who had fled for safety upon the yards, were told by the old cannibal, that if they would come down their lives should be spared, which, after some hesitation, they consented to do. They were sent on shore; and in five minutes after, their dead bodies lay on the beach. The only survivors which Captain Berry contrived to save, were a woman, two children, and a boy. Well might Captain Berry conclude the narrative of his horrid murder by an admonition, "Let no man trust a New Zealander."

To the eastward of New Zealand is an Island of considerable extent and well peopled, discovered by Mr Broughton in 1791, when on a voyage round the world with Vancouver. He called it Chatham Island; the people and its productions the same as those of New Zealand. (See *Vancouver's Voy.*)

It may be proper here to notice a recent discovery

of a group of Islands directly south of the south *Australasia.* cape of Tavai Poenamoo, one of the New Zealand, *Lord Auckland's group of Islands.* named *Lord Auckland's Group*, by the discoverer, Mr Bristow, master of a South Sea Whaler, in gratitude to the nobleman whose name they bear, for having, when a boy, procured him admission into the school of Greenwich Hospital. This group, seven in number, were first seen on the 10th August 1806; and, on the 20th October 1807, Captain Bristow came to anchor with his ship, the *Sarah*, in a fine harbour on the largest Island, which he called *Endorby*, and to the harbour he gave the quaint one of *Sarah's Bosom*. They are situated in lat. 50° 40' south, and long. 166° 35' east. Wood and water being plentiful, and easily procured, they are represented as holding out, in this desolate and remote region, considerable advantages to the southern whale fishery. The climate, however, is unusually severe, and the weather tempestuous. In the middle of summer (December), every day was attended with snow, sleet, or rain. Yet this severity of climate appeared to make no unfavourable impression on the vegetable productions, as the woods were covered with verdure so early in the spring as October. He observed four kinds of timber trees, the principal of which was mangrove (quarry?) growing to the height of 30 or 40 feet; but the trunks were so twisted and turned by the violent winds, that it was difficult to find a straight piece of ten feet in length. There was no want of shrubby and herbaceous plants; there were neither men nor quadrupeds of any kind, but seals, sea-elephants, and sea-fowl, in great plenty. The woods abounded with a great variety of singing birds, with sweet melodious notes, and among them was a species of lark; wild-ducks, seals, and snipes were plentiful, and he caught a kind of rock-cod with the hook and line.

To the southward of the group, another small Island was discovered in 1811, to which was given the name of Campbell's Island; and to the south-west of them, Macquarrie's Islands, in latitude 55° south, and longitude 160° east. Several other Islands are scattered about those of New Zealand; Chatham Island to the eastward of it, and a group of small ones near it, seen by the *Cornwallis* in 1807; *Bounty* Island to the south-east; and to the southward of the latter, a little Island, which, from its position with regard to England, has been named *Antipodes* Island. (Bristow's *MS. Letter.*)

IX. Between the parallels of 48½° and 50° south, and Kerguelen's longitude 69° east, lies the barren and uninhabited Land of Kerguelen; so named from the French officer who first discovered it in 1772, and who, on a second visit in 1773, discovered some small Islands near it, but on neither occasion was able once to bring his ships to an anchor upon any part of the coast. Captain Cook was more fortunate. He had heard of Kerguelen's discovery at the Cape of Good Hope, and wondered he should not have seen this land when he passed it so closely in 1770. In 1776, however, he fell in with these Islands; and, as no account of Kerguelen's voyage had been made public, he gave new names to each Island. Speaking of the main Island—"I should," says Cook, "from its sterility, with *Discovery.*"

Anstralias. great propriety call it 'the *Island of Desolation*,' but that I would not rob M. de Kerguelen of the honour of its bearing his name." He changed, however, the "*Baie de L'Oiseau*" of the French, where they had landed in a boat, and lodged a piece of parchment in a bottle, into *Christmas Harbour*; and called a round high rock "*Bligh's Cap*," which had been named by M. de Kerguelen the "*Isle of Rendezvous*;"—although, says Cook, "I know nothing that can rendezvous about it but fowls of the air; for it is certainly inaccessible to any other animal." Kerguelen thought he had discovered the *Terra Australis Incognita*, but Cook soon determined that it was of no great extent.

The hills were but of a moderate height, and yet, in the middle of summer, were covered with snow; not a shrub was found on this Island, and not more than 17 or 18 different plants, one half of which were either mosses or grasses; the chief verdure was occasioned by one plant not unlike a saxifrage, spreading in tufts, and forming a surface of a pretty extensive texture, over a kind of bog or rotten turf; the highest plant resembled a small cabbage, when shot into seed, and was about two feet high. No land animals were met with, but great plenty of the ursine seal (*Phoca ursina*). Penguins were very abundant, as were also shags, cormorants, albatrosses, gulls, ducks, petterels, and sea swallows. A few fish of the size of a haddock were taken with the line, and the only shell-fish were a few limpets and muscles.

The steep cliffs towards the sea are rent from the top downwards, but whether by rains, frost, or earthquakes, could not be determined; the productions of the hills were composed chiefly of a dark blue and pretty hard stone, intermixed with small particles of glimmer or quartz; lumps of coloured sandstone, and of semitransparent quartz, are also common; nothing appeared like an ore, or metal of any kind. (Cook's *Third Voyage*, Vol. I.)

St Paul
and Am-
sterdam.

X. These small uninhabited Islands are interesting only in a geological point of view. Situated in the midst of the great Indian Ocean, at the distance of 2000 miles from the nearest land, and removed but 18 or 20 miles from each other, they have no common point of resemblance: the one being the product of a volcanic eruption, scarcely yet cooled, with a few mosses and grasses on its surface; the other composed of horizontal and parallel strata of rock, covered with frutescent plants; an appearance which led the scientific gentlemen in D'Entrecasteaux's expedition to conclude, that an organization so regular could not proceed from a volcanic origin. A French seal-catcher, from the neighbouring island, had set fire to the shrubbery, which continued to burn when the navigators passed the Island; and imagining that they saw pits of smoke issuing from the crevices between the strata, some of them were disposed to consider this circumstance as infallible indications of subterranean fire. Perron, the seal-catcher above mentioned, with the gentlemen of Lord Macartney's embassy, who explored the southernmost Island, Amsterdam, says that the shores of St Paul's abounded with pumice stone, but the presence of this light

VOL. II. PART I.

material is by no means an infallible criterion of a proximate eruption.

Of the recent creation of Amsterdam there can be little doubt; indeed, it is scarcely yet cooled, and is altered considerably since its first discovery by Vlaming in 1696. From every part of the sloping sides of the crater, which is nearly 1000 yards in diameter, and into which the sea has forced its way, either smoke, or hot water, or hot mud, are seen to issue; and everywhere is felt a tremulous motion, and a noise heard like that of boiling water. In many parts of the crater, in the centre of which the water is 174 feet deep, the sea-water is tepid from the hot springs below; and numbers of these springs are found on the margin, below the high water mark, of various temperatures, from 100° to the boiling point. One very copious spring, slightly chalybeate, issues, in a copious stream, into the crater, nearly on a level with the lowest state of the tide. These springs cannot possibly descend from the summit of the Island, the highest parts of which are the edges of the crater, about 600 feet, and the whole area of the Island is not more than eight square miles; a surface totally inadequate to collect and condense the clouds, so as to produce these permanent springs. Why some modern geologists, and among them M. de Humboldt, should doubt of sea-water being converted into steam, and undergoing the process of distillation by subterranean fire, we are at a loss to know, or in what other manner they would account for such large and permanent streams of fresh water, so situated as those are of Amsterdam Island.

Another singularity which this Island presents, is in its mosses and grasses, which are all European; to these may be added the *Sonchus oleracea*, or sow thistle; and the *Apium petrosileum*, or parsley; and the common *Lycopodium*, or club-moss, which grows luxuriantly on the bleak heaths of North Britain, seems to thrive equally well on the boggy soil of Amsterdam, heated, at the depth of a foot below the surface, to the temperature of 186° of Fahrenheit's scale.

The crater abounds with an excellent perch, of a reddish colour, which is easily caught with the hook, and may be dropped at once into one of the hot springs on the margin, and boiled alive; and so caught and dressed, we are told, it affords an excellent repast. The bar across the mouth of the crater is represented as one mass of cray-fish; and in the sea, outside the bar, are vast multitudes of whales, grampusses, porpoises, seals, and sea lions, so as to be dangerous for boats to pass. It was the same in Vlaming's time, who "found the sea so full of seals and sea lions, that they were obliged to kill them to get a passage through; when they steered from the shore, there was also an astonishing number of fish."

XI. From the volcanic Island of Amsterdam, we must now take a glance of those innumerable low Reefs and Islands and reefs of rocks which are scattered over the greater part of the Australasian Sea, to the eastward and northward of New Holland, and which are produced by a different operation of nature to that which lifted up Amsterdam—less violent, indeed, and

c

Australasia with less eclat than the latter, but equally, if not more firmly, established on the solid foundations of the deep abyss. A volcanic Island not unfrequently breaks down its supporters, and sinks back into the cavity out of which it was hurled, as was recently the case with the Sabrina Island, near St Michael's; but the Island of coral, created by slow and imperceptible degrees, hardens with time, and becomes one solid mass from the summit to the base.

We know very little, as yet, of the nature of the marine polypi that construct these wonderful fabrics, but we cannot be blind to the effects of their operations. Throughout the whole range of the Polynesian and Australasian Islands, there is scarcely a league of sea unoccupied by a coral reef or a coral Island; the former springing up to the surface of the water perpendicularly from the fathomless bottom, "deeper than did ever plummet sound," and the latter in various stages, from the low and naked rock, with the water rippling over it, to an uninterrupted forest of tall trees. "I have seen," says Dalrymple, in his *Inquiry into the Formation of Islands*, "the coral banks in all their stages; some in deep water; others with a few rocks appearing above the surface; some just formed into Islands, without the least appearance of vegetation; others with a few weeds on the highest part; and lastly, such as are covered with large timber, with a bottomless sea, at a pistol-shot distance." In fact, as soon as the edge of the reef is high enough to lay hold of the floating sea-wreck, or for a bird to perch upon, the Island may be said to commence. The dung of birds, feathers, wreck of all kinds, cocoa-nuts floating with the young plant out of the shell, are the first rudiments of the new Island. With Islands thus formed, and others in the several stages of their progressive creation, Torres' Strait is nearly choked up; and Captain Flinders mentions one Island in it covered with the *Casuarina*, and a variety of other trees and shrubs which give food to paroquets, pigeons, and other birds, to whose ancestors, it is probable, the Island was originally indebted for this vegetation. The time will come,—it may be ten thousand or ten millions of years, but come it must,—when New Holland, and New Guinea, and all the little groups of islets and reefs to the north and north-west of them, will either be united into one great continent, or be separated only with deep channels, in which the strength and velocity of the tide may obstruct the silent and unobserved agency of these insignificant but most efficacious labourers.

A barrier reef of coral runs along the whole of the eastern coast of New Holland, "among which," says Captain Flinders, "we sought fourteen days, and

sailed more than 500 miles, before a passage could be found through them out to sea." Captain Flinders paid some attention to the structure of these reefs, on one of which he suffered shipwreck. Having landed on one of these new creations, he says, "We had wheat sheaves, mushrooms, stag's horns, cabbage leaves, and a variety of other forms, glowing under water, with vivid tints of every shade betwixt green, purple, brown, and white." "It seems to me," he adds, "that when the animalcules, which form the coral at the bottom of the ocean, cease to live, their structures adhere to each other, by virtue either of the glutinous remains within, or of some property in salt-water; and the interstices being gradually filled up with sand and broken pieces of coral washed by the sea, which also adhere, a mass of rock is at length formed. Future races of these animalcules erect their habitations upon the rising bank, and die in their turn, to increase, but principally to elevate this monument of their wonderful labours." He says, that they not only work perpendicularly, but that this barrier wall is the highest part, and generally exposed to the open sea, and that the infant colonies find shelter within it. A bank is thus gradually formed, which is not long in being visited by sea-birds; salt-plants take root upon it, and a soil begins to be formed; a cocoa-nut, or the drupe of a pandanus, is thrown on shore; land-birds visit it, and deposit the seeds of shrubs and trees; every high tide and gale of wind add something to the bank; the form of an Island is gradually assumed; and last of all comes man to take possession.

If we should imagine one of these immense coral reefs to be lifted up by a submarine volcano, and converted into an insular or continental ridge of hills, such a ridge would exhibit most of the phenomena that are met with in hills of limestone.

It is worthy of remark, that, in this great division of the globe, fully equal in extent to that of Europe, there is no quadruped larger than the kangaroo; that there is none of a ferocious character, and, in many of the Islands, none of any description. Man only in Australasia is an animal of prey; and more ferocious than the lynx, the leopard, or the hyena, he devours his own species, in countries too where nature has done every thing for his comfort and subsistence; the consequence is, that population is so much checked and thwarted, that the number of all the natives that have been seen on the coasts of all the Islands, from the first discovery to the present time, would not in the aggregate amount to 20,000 souls. The only hope of improvement must depend on the future colonization of these healthful and fertile regions of the globe by some European power. (κ.)

A U S T R I A .

In strict geographical language, Austria is the name of only a large province in the south-east of Germany, but it is commonly used to denote the great empire, composed of the province in question, the

kingdoms of Hungary and Bohemia, along with the provinces of Moravia, Carinthia, Styria, Tyrol, Transylvania, Galicia, Lombardy, Venice, and Dalmatia. This state has, of late years, undergone fre-

Austria. quent changes in point of territory and population. At the beginning of the French Revolution, the Austrian dominions were computed to contain a population of nearly 25,000,000. This number would have been materially increased in 1796, by the acquisition of Galicia and other parts of Poland, had not the cession of the Netherlands and Lombardy made a deduction, which kept it at nearly its original amount. The diminution, in fact, would have been considerable, had not the French tempted Austria to a separate peace in 1797, by seizing and transferring to her the territory of one of the oldest states in Europe,—the Republic of Venice. In the next war, the splendid successes of the campaign of 1799 at first promised to give back to Austria a portion of her lost territory; but the withdrawing of Russia from the coalition, and the fatal days of Marengo and Hohenlinden, led, in 1801, to a treaty which occasioned a further reduction of the imperial frontier. The third war, that of 1805, was equally short and disastrous, leading, after the overthrows at Ulm and Austerlitz, to the purchase of peace by the surrender of the Venetian territory, Tyrol, and other provinces, containing in all a population of nearly 3,000,000.

In 1809, the resistance of Spain prompted Austria once more to try her fortune in the field. Her army was numerous, and a large proportion of the French force was in the Peninsula; but Prussia remained neutral, and Russia took part, to a certain extent, against Austria. These circumstances enabled Bonaparte, at the head of a mixed force of French and Germans (of the Confederation of the Rhine), to acquire a superiority in the field, and to enter Vienna a second time as a conqueror. This success was chequered, indeed, by a sanguinary defeat at Aspern; but the victory of Wagram reinstated him in his superiority, and the advance of a Russian force left the Emperor Francis no other alternative than peace. A treaty was concluded on terms less humiliating than was anticipated, the cause of which was unknown at the time, but was soon found to be a consequence of Francis consenting to give his daughter in marriage to his conqueror.

By the peace of 1809, the Austrian empire was reduced to a population of 20,000,000. The diminution of her power was still greater from the cession of her frontier line; and France might, for a considerable time, have overawed and controlled her, had not the extravagant march to Moscow deprived Bonaparte, in a few weeks, of that mighty army which appeared to ensure the subjection of the Continent. The subsequent successes of the allies led, as is well known, to the restoration of Austria in more than her former splendour.

We shall now proceed to give some account of the present state of this empire under the following heads: Population—Climate and physical aspect—Education, Arts and Sciences—National Character—Religion—Government and Laws—Army—Finances—Agriculture—Mines and Manufactures.

Population. 1. The treaty, or act of Congress at Vienna, in 1815, and the subsequent treaty of Paris in the same year,

have confirmed Austria in the possession of the following territories:

Bohemia, containing a population of	3,150,000
Moravia	1,320,000
Austrian Silesia	300,000
Lower Austria	1,050,000
Upper Austria	650,000
Salzburg and Berchtolsgaden	200,000
Styria	800,000
Carinthia	280,000
Carniola	420,000
Friuli and Trieste	106,000
Galicia	4,850,000
Bukowine	250,000
Hungary	7,400,000
Transylvania	1,600,000
Sclavonia	500,000
Croatia	350,000
Venetian States	1,650,000
Istria	100,000
Dalmatia	300,000
Tyrol	650,000
Lombardy, and other acquisitions in Italy	2,000,000
Total	27,926,000

Yet this empire, so populous and fertile, wants, in a high degree, that consonance of national manners, and that congeniality of national feeling, which are so essential to ease in governing, and have so long formed the strength of France and Britain. Hungary and Bohemia, which form so large a portion of the imperial dominions, have little connection or conformity with each other, and still less with the remote provinces of Galicia or Lombardy. Add to this, that the Austrian cabinet, while inferior to none in diplomatic finesse, has frequently acted with a blind adherence to old prejudices, which we should little expect in a European state in the eighteenth or nineteenth century. Frederick II. who had such bitter contests with the Austrians, both in the field and cabinet, declares that, in the former, they were unconscious of the value of good generals, while in negotiation they were perfectly untractable, so long as the aspect of affairs justified, in any degree, their exorbitant demands. What better opinion were we at liberty to form in the present age, when we saw their army entrusted to a Mack, and preparations of defence delayed until the French were marching on Vienna? The grand source of future aggrandizement to Austria is to be sought, not in the acquisition of additional territory, but in the improvement and consolidation of her present dominions. This doctrine, applicable to all countries to an extent seldom apprehended by their rulers, is of the most urgent importance to a state, whose deficient instruction, languid intercourse, difference of language, and blind attachment to hereditary usages, all concur to keep so many fellow-subjects in a state of alienation from each other.

It has become customary, particularly of late, to consider Russia as superior in resources to Austria;

Austria. an opinion sanctioned, among other authorities, by an expression of Lord Grey, in one of the debates which regarded the conduct of our ministry of 1806-7, in respect to foreign affairs. On considering, however, the rigour of the Russian climate, the barrenness of a great proportion of the soil, the inconvenience of vast distances, and the general barbarism of the people, we are disposed to withhold our assent from this opinion, and to look with more confidence to the probable augmentation of the population and power of Austria. The following table will convey an idea of the relative density of the population of her different provinces:

	Inhabitants per square League.
Bohemia	867
Austrian Silesia	847
Lower Austria	766
Moravia	748
Galicia	732
Croatia	657
Upper Austria	554
Styria	504
Hungary	495
Military frontiers of Sclavonia	470
Carinthia	453
Sclavonia	440
Transylvania, and its military frontiers	437
Military frontiers of Croatia	390
Bukowine	318
Military frontiers of Hungary	295

It is remarkable, that Lower Austria, though highly fertile, is not so well peopled as the manufacturing countries of Bohemia and Silesia. It is still more remarkable, that the mountainous tracts of the latter are found to contain a denser population than the rich plains of Hungary. The average of the whole empire is 579 inhabitants to the square league, a proportion hardly more than the half of that of France and England. Can there be a more striking proof of the improveable powers of the empire, when we consider that, of the countries just mentioned, the latter is, in point of soil and climate, inferior, and the former by no means superior to Austria?

No country, with the exception of Russia, comprises such a diversity of distinct tribes or races as the Austrian empire. The German part of the population does not extend in considerable numbers beyond the provinces of Upper and Lower Austria, a portion of Moravia, and particular parts of Styria and Carinthia. Bohemia, although surrounded by a German population, contains many districts inhabited only by its aboriginal tribes; while, in Hungary and Austrian Poland, individuals of German extraction are very thinly scattered. The most numerous of the varied races of this empire is the Sclavonian, a generic name now in a great measure lost in the subdivisions of Croats, Rascians, Carniolians, Bosniacs, &c. The Rascians, or Illyrians, are descendants of the ancient inhabitants of the vast tract known to the ancients by the name of Scythia. The fate of war has placed them alternately under the Turkish and Austrian dominion; their language is a dialect of Sclavonian mixed with the Illyrian. Some of their

tribes lead a pastoral life, and follow the habits of plunder natural to wanderers; while others are stationary, and have made some progress in the ruder kinds of manufactures. Jews are scattered in various directions throughout the Austrian dominions, particularly in Bohemia, Moravia, and Galicinia. Without being numerous, they find means, especially in Galicinia, to transact most of the mercantile affairs of the country.

Hungary, the most extensive and most fertile of the great divisions of the Austrian Empire, is perhaps the most backward in point of civilization and knowledge. Many a rich tract, capable of supporting a crowded population, is here allowed to remain in pasture, in consequence, partly of the ignorance of the cultivators, and partly of that most absurd law which deprives the peasant of the right of holding landed property. The extent of the evil is most sensibly felt throughout Lower Hungary, the inhabitants of the northern part of the kingdom being accustomed to greater exertion, and being even known to possess occasionally little properties of their own. Another cause of the ignorance and backward state of Hungary, is the difference in point of language, manners, and religion, of various portions of its population. These have settled in it at different times, and from different causes, without becoming blended with each other in the manner that takes place in an industrious and populous community. The majority of the Hungarian tribes are of Sclavonian descent, but they are mixed with a variety of other nations, such as Armenians, Jews, Macedonians, and followers of the Greek church. The few Germans settled in Hungary are originally from the south of the empire, particularly Suabia and Bavaria.

Bohemia reckons above three millions of inhabitants, the chief part differing, both in language and in national feeling, from their German neighbours. They have even a decided aversion to the latter, and confine their national predilection to the Hungarians, who are said, in return, to esteem them more highly than their other fellow-subjects. The power of the Sovereign is much greater in Bohemia than in Hungary, for it comprises the legislative as well as the executive department. Notwithstanding this strange anomaly, Bohemia is the least backward of the Austrian provinces, whether we look to education or the labours of productive industry. The efficacy of regular habits, and of a compact population, in bringing aid to the executive power, is strikingly exemplified in the number of soldiers raised in Bohemia,—a number almost equal to that which is supplied by the far more extensive territory of Hungary.

2. The difference of elevation of soil causes as great a difference of temperature in the Austrian empire as in any country in Europe. At Vienna, situated less than 400 feet above the level of the sea, the medium of annual heat is about 51° of Fahrenheit; at Gratz, a degree farther to the south, the medium is only 49°, the elevation being nearly 700 feet. Again, on the eastern frontier, Saltzburg, situated in the vicinity of an Alpine range, has an average temperature of only 47°, while at Prague, two degrees farther north, it is 48°.

Austria.

Vienna, situate in a plain, intersected in a variety of directions by the Danube, the waters of which are here slow in their course, would be by no means healthy, were it not for the frequent breezes, which clear the air of unwholesome exhalations.

The Austrian dominions may be divided, in point of climate, into three regions, of which the southern comprises the provinces adjoining to Italy, with a part of Croatia, and extends from N. lat. 42° to 46°. We here find the olive, the myrtle, the vine, the fig-tree, and even the pomegranate. The depth of winter may be compared to the month of March in a northern climate. The middle range extends from the 46th to the 49th of north latitude, comprising Austria, properly so called, a great part of Hungary, and a portion of Moravia and Bohemia. The olive is no longer found to grow in this latitude, but vines and maize thrive in favourable situations. Winter lasts between three and four months; the spring is mild, though rainy; the summer warm but variable; the air is in general healthy, except in the neighbourhood of the marshes of Hungary, which are proverbially fatal to German settlers. The northern region comprises Galicia, a part of Hungary, a great proportion of Bohemia and Moravia, with the whole of Austrian Silesia. Winter is here severe, and lasts fully five months; vines and maize are no longer to be met with, and even wheat requires a choice of situation; but the summer heats, particularly in the valleys, are greater than we are accustomed to in Britain.

If we cast our eyes on a map of the imperial dominions, as, with the exception of the Polish part, they stood before the late annexations, we see them surrounded by a chain of mountains in almost every direction. Hungary is covered by the Carpathian range, which extends all the way to Silesia, and is even connected with the great circular barrier of Bohemia. To the eastward lies an elevated territory, in the direction of Bavaria, while, in the south, the line of discrimination from Italy and Illyrium is drawn with still more marked features. The highest mountains belong to the southern range; those of the north seldom exceeding two or three thousand feet, while those of the south frequently approach to four thousand. In the interior of the empire, and particularly in Hungary, there are levels of great extent, and the average height of many of the hills may be put down at only six or eight hundred feet. Strictly speaking, the whole of the mountains along the southern part of the Austrian dominions, and even those on the north, belong to one great range, extending, under a variety of modifications and names, all the way from the Alps to Russia. The latitude being temperate, or rather warm, these varieties of elevation present a striking difference in vegetable produce; the lower part being covered with vines, or rich crops of corn, while the adjacent elevation exhibits a picture of Norwegian sterility. Some provinces abound with picturesque views, and remind the traveller of the magnificent scenery of Switzerland. Styria, in particular, has its glaciers and perpetual snows, its rumbling cascades, its tremendous avalanches, and its green pasturages, in the region of mist.

Austria.

Lakes are frequent in certain parts of the Austrian dominions. In Upper Styria, they owe, as in the Highlands of Scotland, their formation to the natural collection of water in valleys pent up in all directions; a description, however, which does not apply to the lakes in the level part of Hungary. Those are more properly marshes, and form, as in modern Greece, a striking indication of neglected agriculture. Large tracts are in this manner lost to every useful purpose along the banks of the Danube, the Drave, the Save, and other rivers of less magnitude.

Hungary may be called a vast plain of sandy soil, marked in certain districts by the highest fertility, in others by absolute barrenness. Galicia is less level than Hungary, but may likewise be called, in general language, a sandy plain of great extent. Moravia is marked by more prominent features; and while its soil presents, on the southern slope of its hills, the fertility of Lower Austria,—the northern side is found too cold for the cultivation of the grape. The inhabitants are active, and at a farther distance from primitive simplicity than the majority of their fellow-subjects. But the garden of Austria, and indeed of Germany, is the great valley, extending on either side of the Danube, to a considerable way above Vienna. Unfortunately, the riches of nature have not as yet been adequately improved in this region; the peasantry, though possessed of the greatest honesty and sincerity, being devoid of intelligence or activity. These good and bad qualities are not confined to the country; they form the groundwork of the character of the inhabitants of the capital, although necessarily modified by the habits produced by permanent assemblages in one spot.

The Austrian territory is traversed by a number of rivers, of which by far the most interesting is the Danube. It receives about 40 rivers from north and south, before entering the imperial dominions, and about 100 more flow into it before it falls into the Euxine, after a course of nearly 1500 miles. Its bed becomes perceptibly widened by the influx of the Ens, at some distance above Vienna; and its subsequent breadth, though very various, may be said, in a general way, to be of one, two, or three miles. It is bordered throughout almost its whole course in the Austrian territory by ridges of mountains, the distance of which from the water is generally greater on the right than on the left bank. It is of sufficient depth to bear shipping throughout the whole Austrian dominions, and to admit, in Hungary, of vessels of considerable size. But, unfortunately, this noble stream is not fitted for easy navigation; its banks are often steep and rocky, its current rapid, and its bed encumbered with shoals. The height of the banks and the frequent windings prevent the use of sails to the extent practised on the Rhine and the Vistula. It is necessary, therefore, to tow almost all the way, and the boats, as well as the track along the banks, are as yet in a very rude state. A similar negligence prevails in regard to Canals, in which the Austrians have hitherto made very little progress.

The Austrian rivers, and in particular the Danube, teem with myriads of fish. The same is true of the various lakes scattered in different parts of the coun-

Austria.

try. Some kinds of salmon in the Danube are of so rich a flavour as to enter regularly into the list of presents made by the princes residing in the neighbourhood of its banks to their respective superiors. An attempt was lately made to convey some of this choice breed to the Rhine, by putting them into boats of such a construction as to admit the ingress of the water. The plan was to tow these boats up the Danube, as far as Ulm, and afterwards to reach the Neckar by means of some of the lesser rivers. It failed, however, and the undertakers had the mortification to see most of the fish perish by the way, in consequence, perhaps, of the smallness or improper construction of the boats.

Education,
Arts and
Sciences.

3. There exists, in point of education, a remarkable difference between the North and South of Germany. This difference is owing to the operation of political and moral causes—such as the difference of the form of government; the greater number of free towns in the north, and of public establishments; and, above all, to the predominance of Protestantism. It has long been a point of fashion and competition among the petty princes in the central and northern parts of Germany, to patronize literature. *Un homme de lettres* is there, as in France, a personage of considerable importance. Attempts have indeed been made, during the last and present age, by Joseph II. and the late Sovereign of Bavaria, to improve the universities, and to found academies, in their respective territories. The Academy of Munich, in consequence of the patronage of the latter, now occupies a prominent rank among literary bodies; and in Vienna, considerable progress has been made in the method of teaching Medicine, Surgery, and Botany. But in other respects, whether we look to schools or universities, the state of instruction in Austria is very imperfect. The innovations of Joseph were too abrupt to last; they have all disappeared except his primary schools. The hereditary states alone possess the means of tolerable education, the great provinces of Galicia and Hungary being in a manner deprived of them. Still there exists throughout this empire a patient and pains-taking industry, which will eventually prove highly favourable to the dissemination of useful knowledge. A stranger, on entering a German school, is struck with the arrangement, the gravity and the silence that prevail throughout. Several towns in Austria have Gymnasia or Academies somewhat similar to the Lycées in France,—calculated for teaching, not so much the classics as the introductory part of Mathematics, Medicine, or Law.

In the Academy of Medicine and Surgery at Vienna, the buildings are spacious, the professors numerous, and well qualified. The access to great Hospitals, to collections of Natural History, and to an extensive Botanical Garden, are all important facilities appended to this seminary. In fact, Vienna has held a distinguished rank in medicine since the days of Van Swieten, the opportunity of practical observation afforded by a large city, and the liberality of the public establishments, rendering this capital the resort of medical students from distant provinces; exactly as Göttingen is the point of attraction for moral and natural philosophy. Chemistry, however, has

hitherto been little cultivated at Vienna; natural history more.

Austria.

Vienna has likewise an Oriental Society, a Veterinary School, and some institutions for teaching the Fine Arts. These, however, are all, except the medical, inferior to correspondent establishments in the north of Germany. Another subject of regret is, that a youth, after making a certain progress at school or college, finds little means of farther advancement from instructive society at Vienna. A thirst for information is little felt among a people occupied only with the tranquil enjoyment of the good things of this life; a people unambitious, uninquisitive, and disposed to go over the same tract as their fathers and forefathers. It is in scenes of agitation that the faculties are called forth; they become dormant in a state of general and continued acquiescence. The only feeling likely to stimulate minds of this heavy texture is the desire of acquiring property; and, in fact, trade of one kind or other forms the chief sphere of individual activity throughout the south of Germany. Such is the true cause of that literary apathy ascribed by some foreigners to the restraints imposed by government on the press;—restraints of no great severity, and certainly not intended to check the progress of useful inquiry.

Still Austria is not wholly devoid of names of eminence in literature. Frederick Schlegel is well known by his publications on the language and philosophy of India, and his brother William, by his translation of Shakespeare, and by his admirable works on dramatic criticism. To these are to be added the names of a few poets, and of a greater number of geographical and statistical writers. Hammer, the founder of the Oriental Society at Vienna, has published a translation of a Persian poem of some extent, and, like Wieland, has laboured to transpose into the German language the ornaments of the figurative style of the East. Etymology is a study suited to the laborious habits of the Germans, and on this, as on many other subjects, they have given us, if not finished works, the materials at least of valuable compositions. With the application of a better method, and with rigid compression, a variety of useful treatises might be extracted from the labours of the German literati.

Prague has a university of high antiquity, but of little reputation at the present day. The Catholic clergy are generally educated in humbler seminaries than universities. Without much pretension to literature, they bear the character of conscientious attention to their pastoral charge, in particular the country curates. Oratory forms no part of their studies; a German congregation meets, not for the purpose of being gratified by a pathetic address, but of fulfilling, soberly and tranquilly, a religious duty. Sermons in this country consist, accordingly, of little else than plain moral lessons, deduced from the Sacred Writings; and the reputation of a pastor rests chiefly on his attention to the sick, and the performance of private and unostentatious duties.

Several establishments have been formed of late years in Austria for the education of officers. The principal is the Military Academy of Wienerisch,

Austria. Neustadt, in the neighbourhood of Vienna, where the teachers are generally Engineer officers, disabled by wounds or otherwise from service. The pupils consist of young officers, or of youths of genteel families, preparing for the service. There are two other military seminaries in the capital, and some smaller establishments in the provincial towns.

As to travelling for the purpose of information, the Austrians have in general much less inclination than the English, or their German brethren in the north. Some examples, however, there are of men of science repairing to distant regions, such as M. Jacquin and Mohs who went to America in quest of plants unknown in Europe. Schultes, Gebhast, Mebzer, and Bremer, have also found means to render their travels instrumental to the diffusion of knowledge.

In mechanical inventions the Austrians have made that progress which may naturally be expected from a people, who, with a deal of patience and perseverance, are not in possession of the advantages of improved machinery. The result of their discoveries is, therefore, rather the gratification of a fancy, than that practical application to a productive purpose, which tends so greatly to cheapen labour in Britain. One German artist frames a machine to perform the functions of a chess player; another makes a head capable of an imitation of the human voice, while a third combines in a *panharmonicon* the most varied sounds of music. That instrument may, in fact, be called a concert in itself, a number of instruments being made to play simultaneously with the greatest precision.

The fine arts, with the exception of music, have hitherto made little progress in Austria. To find an eminent painter or sculptor there would be a matter of no small difficulty. But when we come to think of music, who can forget that Haydn and Mozart were formed at Vienna? If they are inferior in grace and melody to Italian composers, they are not to be surpassed in the grander powers of music. A foreigner cannot receive a higher gratification at Vienna, than by being present at the Oratorio in commemoration of Haydn. Architecture is still in its infancy in Austria. An Architectural Society has been lately instituted at Vienna, but most of the public buildings have been planned by foreign artists. Engraving, demanding rather patience than exertion, has been cultivated there with considerable success.

National Character.

4. The Austrian national character is marked by the same features as that of the German nation at large. Sincerity, fidelity, industry, and a love of order, are all conspicuous in them, and would long since have entitled them to fill a distinguished rank in the scale of European civilization, had not their beneficial operation been counteracted by a prejudiced government, a deficient system of education, and an illiterate priesthood. The consequence of these unfortunate drawbacks is the transmission of similar habits from father to son, a blind adherence to old usages, and an extravagant deference to hereditary rank, in the promotion of civil and military officers, which proved one of the great causes of the continued defeats in the late wars with the French.

In Austria, as in Britain, females enjoy a great-

er degree of freedom before marriage, than it is thought expedient to allow them in France. In domestic life, they act a modest and attentive part; fixing the predilection of their husbands, not, indeed, by the attractions of conversation, but by a mild and steady fulfilment of the duties of a wife and mother. They are thus probably more happy than the fair sex in France, although possessed of much less influence, and occupying a less conspicuous part in society. The lower orders are distinguished by similar virtues. In some districts we may visit village after village, without hearing of a single instance of domestic disquietude. The care of children, the habit of labour, and attendance on Divine worship, occupy all their thoughts. In Vienna, females form the chief attraction of society to a foreigner. Most of them speak French with fluency, and prefer it to the Austrian dialect of German, which is particularly unpleasant, having a slowness of accent and a hissing tone, extremely ungracious, particularly in the mouths of the common people.

The habitual assiduity of the Austrians leads them to cultivate, by preference, those occupations in which straight forward industry affords the means of success. Hence their progress in mechanics, and the flourishing state of many of their manufactures. Another feature in the German character, and one at first somewhat difficult of explanation, is their predilection for music; a passion found to exist in the humblest ranks, and under the least favourable circumstances. We meet here, in villages, with wandering musicians performing on trumpets made of the cherry-tree wood, or on the most grotesque violins. If in vocal music they yield to the Italians, they fully maintain the competition in point of instrumental performances—a taste which prevails as well in the fertile parts of the empire, as in the secluded spots of Tyrol and Carniola; forming a curious example of the results attendant on the continued prosecution of an elegant study by a slow and apparently inanimate people.

No country presents fewer examples of criminal offences than Austria. Year passes after year, without any necessity for the infliction of a capital punishment. Averse as the inhabitants are to Frenchmen, particularly in the shape of military invaders, we know of no example, during any of the late invasions, of those secret assassinations which occurred so frequently in Spain.

Of the manners of the inhabitants of the mountainous provinces of the empire, we may form an idea by fixing our attention on the Styrians and Carinthians. The middle range of these mountains presents a scanty pasturage; their upper parts are covered with tracts of snow, while the yew and fir are the only trees which are seen to raise their heads amidst the tempest. The inhabitants of these elevated districts are simple, hospitable, and religious; content with the produce of their land and cattle; cheerful and frank as simplicity and moderate desires can make them, they have no wishes beyond the limits of their own territory. The only feeling which prevails among them with any keenness, is religious zeal. They are ardent Catholics, and open to all the idle suggestions of an illiterate priesthood.

Austria.

Austria. They are in the habit of undertaking distant pilgrimages, which they are taught to consider as the best means of obtaining the forgiveness of trespasses. Along their roads are scattered mystic chapels, crosses, and other indications of the exercises of devotion. The traveller is often fortunate enough to find beside these religious erections a spring whose waters afford him a delightful refreshment, when pursuing his way along a confined valley. He finds himself here among a primitive race, who are unacquainted with the arts of men in a more civilized state, and are easily guided by an appeal to the heart. Their language is sonorous, and the echo which repeats the call from the mountain side, often proves a useful warning to the stranger when wandering from the path, or when approaching to the brink of a precipice. Often, in the course of his journey, does he meet with inscriptions, in which the hand of a friend or a brother has recorded the name of one who has fallen a victim to the storm or the torrent.

Religion.

5. Austria has long contained a considerable diversity of religious sects, without having suffered from their contests in any part of her dominions except Bohemia, the country of the well known John Huss, and Jerome of Prague. In the other provinces such excesses have been avoided, partly from the moderate character of the inhabitants, and partly from the tolerant spirit of the Imperial Family. There can be no doubt, however, that, had the Reformation happily made progress in the Austrian dominions, the result, as in the north of Germany, would have been a very material advancement in all departments of productive industry. Trade, manufactures, literature, are all cultivated with superiority in the north; and if the agricultural produce of the south be larger, the cause is to be sought merely in superiority of soil and climate. Toleration, however, existed virtually for a considerable time back in Austria, and it received a formal sanction from a law of Joseph II., which extended indulgence even to Jews and Mahometans. The Archbishop of Vienna is the head of the Catholic clergy in a civil capacity; but the Bishop of St Palten appoints the regimental chaplains, and is accounted the superior of all clergymen doing duty with the army. Church patronage rests with the Sovereign, to the exclusion of the influence of the Pope. Convents, formerly numerous in Austria, have been considerably reduced during the last thirty years; but the church property is still very considerable.

In computing the relative number of different sects, it is common to estimate the Catholics at two-thirds of the whole. Protestants are not numerous; the Austrian people at large being too little enlightened to exchange a worship which dazzles the imagination by its pomp and ceremonies, for one whose chief appeal is to the understanding. The Greek church has no inconsiderable number of votaries scattered throughout Galicia, Hungary, Croatia, and Transylvania. These are superintended by a number of Bishops, some of whom recognise for their head the Archbishop of Leopold, while others, who differ in point of creed, are under the jurisdiction of the Archbishop of Gran in Hungary. The latter are

particularly numerous in Transylvania. The followers of the Greek church, in one part or other of the Austrian dominions, are said to exceed the number of 2,000,000;—a number in a state of gradual increase from the occasional influx of their brethren from Turkey. These new settlers are generally engaged in trade, and pass for possessing no slight share of the address and artifice attributed to the Greek merchants of the present day. Galicia comprises a body of Armenian Catholics; a sect not wholly unknown in Hungary. The Protestants, including both Calvinists and Lutherans, amount, probably, to nearly 3,000,000 throughout the whole empire, of which Bohemia and Moravia contain a very insignificant proportion. The well known association of Herrnhutters or Moravians, owes its origin to an Austrian province, and takes date from the middle of the fifteenth century. The number of Jews under the Austrian dominion may amount to 300,000. Joseph II. took the lead of Bonaparte in an attempt to incorporate them with the mass of his subjects, by extending to them the enjoyment of similar privileges. He found, however, that their habits, if they yield at all, give way but very slowly, and that ages will be required to identify them with their Christian fellow-subjects. In tolerating Mahometanism, Joseph had in view the promotion of commercial intercourse with Turkey, a number of traders of that country being in the habit of travelling, and even of settling in Austria.

6. There exists a great diversity in the constitution of the component parts of this extensive empire. **Government and Laws.** It may be safely assumed, that the disadvantage from want of unity, already noticed, will infallibly continue to a considerable extent, until there be established a greater similarity in point of legislation. At present, each of the great divisions constitutes an unconnected body, and the whole resembles rather a federative association than one compact consolidated state. In the Austrian provinces, the constitution is understood to be founded on a great charter, passed so long ago as 1156. In Bohemia, the principal laws are of more recent date, and hardly go back two centuries. In Austrian Silesia, there exists a great complexity of public regulations, while Galicia, differing still more essentially from the other provinces, traces back the basis of its constitutional dependence on Austria no farther than 1773.

Hungary is wholly distinct from the other divisions of the monarchy, and claims to be governed by laws altogether different. The first of these is traced back so far as the end of the ninth century; others date from the thirteenth, and confirmations of the privileges of the nobility, with limitations of the imperial power, were successively passed during the seventeenth and eighteenth centuries. Here the emperor exercises the supreme power, only through the medium of the States or Parliament. He may dispose of the great offices of the kingdom, but under the restriction of giving them not only to natives of Hungary, but to men of a certain rank. In this land of aristocracy, no plebeian, of whatever talents, is entitled to rise in a public office above the humble station of a clerk. The Emperor is accounted the constitutional President of the Diet, but he

Austria. may delegate a representation to one of his great officers. A general levy, or "insurrection," as it is termed, must, like other measures, proceed from the legislative assembly.

The States, or parliamentary meetings, differ in different provinces of the empire, but are generally divided into four classes; the prelates, the higher nobility, the knights, or gentry, and the deputies of the boroughs. It is a general meeting of these classes that constitutes the Hungarian Diet. The prelates have the right of voting first. The nobility possess not only an exclusive title to public appointments, but the daughters of the less affluent families among them are admitted to an establishment in convents, on proving their rank, or, as it is called, the number of their quarters, in the manner pointed out by law. The Diet of Hungary is generally convened once in three years, and meets at Presburg or Buda. The Prince Palatine, or, in his absence, the noble of highest rank, presides at the *Tabula procerum*, having on his right the primate, along with the archbishops, bishops, and other dignitaries of the church. The second board, or *Tabula inclitorum*, has for its president the imperial representative, while the third division of the Diet comprises the deputies of towns, the secretaries, and other inferior officers. The deliberations proceed either on the propositions of the sovereign, or on the bill of grievances of the subjects. The Diet is generally divided into chambers, who discuss business separately, and communicate with each other by the medium of members. In case of non-agreement, the whole are made to constitute one assembly, in which a decision is made by plurality of votes. An act of the Diet receives the force of law when sanctioned by the Emperor, or King, as he is invariably termed in Hungary, and it seldom happens that any serious division takes place between the Diet and the executive power.

Such was formerly the extravagance of aristocratic notions in Hungary, that no plebeian, or person engaged in trade, could carry on, in his own name, a law-suit against one of the gentry. It was necessary that the town where the plaintiff resided, should come forward and assume the cause of its citizen. This absurd usage was abolished in 1802. Still, however, a peasant or farmer can seldom bring, in his own name, an action against one of the gentry; he must generally do it through the medium of his superior or landlord. The right of possessing land in Hungary being confined to the privileged classes, it follows that a donation of land by the Sovereign is tantamount to conferring a title of nobility. The land cultivated by the vassal is, of course, altogether the property of his superior; but arrangements are made for allowing the former to reap, as far as that is practicable, in so ignorant a country, the fruit of his labour. The corvees and taxes on the *tiers etat*, so much complained of in France before the Revolution, prevail here in all their extent. Hence the importance to the boroughs of acquiring the privileges of free towns, and enabling their inhabitants to possess land without a title to nobility.

The Hungarian landholder is exempt from all imposts. Tithes, toll-dues, a tax called the thirtieth

VOL. II. PART I.

Austria. penny, the contributions for soldiers, all pass over his head, unless he become pledged to them, along with his brethren, by a specific act of the Diet. In return for all these exemptions, they are bound to rise *en masse*, and to serve personally under their Sovereign, whenever a war receives the approbation of a General Diet. It will not escape the observation of our readers, that these fiscal privileges, always the subject of boast among the Hungarian noblesse, and, in former years, not unfrequently a ground of quarrel with their Austrian Sovereign, do not amount, in fact, to anything like an entire exemption. Public burdens, however disguised, fall eventually, with a considerable share of equality, on all classes. In Hungary, the inhabitants of the towns are obliged to seek, in the enhanced price of the commodities, sold to the landholders, an indemnity for their greater share of taxation. The late Emperor Joseph II. was disposed to abrogate many of these pernicious usages, but his character was not well fitted, nor did he reign long enough to accomplish the task.

In the hereditary provinces, or Austria Proper, the power of the Emperor is much greater. In the eye of the law, he is the supreme judge, the fountain of dignity, the centre of legislative as well as of executive power. He has a right to impose taxes, to regulate the affairs of the church, and even to modify religious worship, in whatever is not accounted a fundamental article of faith. He may tolerate any religion, oppose the papal bulls, and prohibit the publication of the pastoral letters of bishops. This power, delicate as it is in a Catholic country, has been sometimes exercised by the emperors, when they had occasion to urge political points of importance with the sovereign pontiff. At such times they have not scrupled to forbid their subjects to remit money to Rome, and have been known to interdict all correspondence between the Austrian and foreign convents. A more important prerogative is that which they possess to impose taxes on church property throughout Austria and Galicia.

The executive government of the Austrian empire at large consists of four great departments, and owed its present organization to the counsels of Maria Theresa. One of these establishments regulates all home affairs; foreign affairs are managed by another. Military matters are subjected to the third great department, while the fourth and last regulates the interior administration of Hungary. The name of Aulic is not confined, as is vulgarly imagined, to the Military Board; it is common to several councils, and is given, among others, to the Board of Finance. Another department, sufficiently indicative of the backward state of the science of government in Austria, is that which superintends the working of mines for public account.

In this country, as in France, the attention of government has been lately given to a more easy exposition of the fundamental rules of jurisprudence. A first attempt was made so long as forty years ago, and a code was published in 1767 in eight folio volumes. This performance had two great defects, its size and its want of classification by general rules. While of little use to lawyers, it was wholly unprofitable to the public at large. Instructions were accordingly

D

given to an eminent civilian, Von Horten, to recast it in a condensed and improved form. Considerable progress was made in this before the death of Joseph II.; and in 1794, under the auspices of the present sovereign, the first part of the civil code came forth in a new form. A few years after, the whole appeared in an amended shape, and government appointed several local commissions, with instructions to make reports on its applicability to the different provinces. Printed copies of the code were distributed in all directions, and the universities enjoined to take it into mature consideration. The definitive correction and promulgation of the code were retarded by various causes, and particularly by the unfortunate wars with France, so that its actual adoption did not take place until the beginning of 1812. The criminal code had not been so long withheld; it was promulgated in 1803, and introduced into practice in 1804.

Military
Establishment.

7. In a country where the executive power is not subjected to animadversion, or to the exhibition of official statements, it is a matter of no small difficulty to compute the extent of the military force. It was supposed that, in the campaign of 1805, the Austrians had on foot above 250,000 *effective* troops, of whom nearly a fifth were cavalry. In that of 1809, this force of regulars was backed by a considerable body of reserve, and by above 100 battalions of militia, known by the name of *landwehr*; but the state of discipline of the latter was not such as to offer any effectual resistance to the progress of the French. The war establishment, in *regular* troops, can scarcely be estimated, we apprehend, above 250,000 men; and half this number may perhaps be taken as near the amount of her *effective* peace establishment.

The *irregulars* in the Austrian service are drawn, in a great measure, from Croatia and other provinces along the Turkish frontier. About sixty years ago, the greater proportion of the Hungarian troops fell under this description; but the wars with Prussia having taught, by dear bought experience, the value of discipline, the Austrian commanders, in particular, Marshal Lascy, gradually accomplished a change, and converted hordes of flying squadrons into compact and regular regiments.

In the Hereditary States, and we believe in all the empire except Hungary, the levies are made, in the first instance, for militia duty, from which it is no difficult matter, in an absolute government, to accomplish a transition to the line. In Hungary, recruits are levied in virtue of an act of the Sovereign and the States, after the promulgation of which, the different Magnates find means to enlist the requisite number on their estates. The chief disadvantage of the necessity of a legislative sanction in Hungary, is the publicity thus given to the extent of military preparation. The length of service in the Austrian army has undergone alterations during the present age, and it now admits, as in Britain, of limitation by periods. In time of peace, the officers have no difficulty in obtaining a furlough for the greatest part of the year. Veterans and wounded men are entitled to admission at the military hospital of Vienna, or to a small out-pension.

Though, to an English traveller, manufactures

would appear to have made little progress in the Austrian dominions, they stand on a footing equal to that of their continental neighbours, and supply government with most of the materials of war. Clothing, arms, ammunition, harness, are all furnished at different stations in Bohemia, Moravia, and the Hereditary States. The horses for the light cavalry are drawn from Hungary and Galicia; those for the heavy cavalry, chiefly from Bohemia and Moravia. The disposition of the inhabitants of most of the imperial territories, is well adapted to a military life. They are generally accustomed to pass their time out of doors, to indulge in active exercise, to follow the chase, and to occupy themselves with the care of horses. To such men marching and encamping is but a slight variation from established habits. The fire of the nightly watch is not more uncomfortable than that of their smoky cottages; while a loaf of bread, a slice of coarse pork, and a glass of spirits, supply them with all the nourishment they desire. In point of resources, therefore, Austria is one of the greatest of military powers,—her deficiency has hitherto been in their application. Too much attention is given to the *minutia* of individual exercise, without considering how seldom these niceties can be made applicable to collective numbers. Hence an endless list of military instructions, and a complexity of evolution, such as to be hardly practicable in a review, still less in a day of battle. At the same time, there exist very material omissions in regard to the method of moving large bodies of men. Will it be believed, that the Austrian regulations contain no explicit directions for a change from line into column, whether for attack or defence! Hence, in a great measure, the loss sustained at Essling and Wagram by long exposure to the French artillery. Official instructions are given for the manœuvres of battalions and regiments, but nothing is said of those of brigades, or larger divisions. The consequence is, that the Austrians form their line very slowly, and find, when it is once formed, a deal of difficulty in executing any other movements than those to front and rear. They have very little dexterity in separating, reuniting, or supporting each other at short notice.

The military schools at Vienna having been found highly useful, the government has adopted the plan of establishing them elsewhere. The consequence, it is to be hoped, will be a gradual correction of the defects hitherto attendant on deficient education and blind patronage. Few services are more discouraging than the Austrian to an officer who has not the advantage of rank.

8. In Austria, a country possessed of very little foreign trade, the taxes are chiefly levied on the land, and on objects of interior consumption. Joseph II., desirous of new modelling this as well as other departments, proposed the adoption of a land and poll-tax on a uniform plan. As a necessary preliminary, arrangements were made for a general survey of the landed property of the empire, and several years devoted to that important operation. It was, however, too unskillfully conducted to afford anything like a satisfactory ground to estimate the value of the different properties. No adequate allowance was made for the difference of plain and mountain, of fertile or barren

Austria. tracts. The consequence is, that the collection of this department of the revenue is still in a very imperfect state, although the tax on land and houses (*impôt foncier*) forms necessarily the chief part of the Austrian revenue. In Bohemia, Galicia, and the Hereditary States, this important tax falls equally on all classes; in Hungary and Transylvania, it is borne, as we have already observed, by the farmers and inhabitants of towns, to the apparent total exemption of the noblesse.

The imperial demesnes form also a considerable branch of the Austrian revenue, particularly in Galicia. This source of income, which would be very great in a country like Holland or Britain, where landholders and farmers of capital would take the land at a rent, and relieve government of all farther superintendance, is comparatively inconsiderable in a country where the administration either has not the means or the judgment to throw off its hands, a task which must always be unprofitably managed by servants little interested in the produce of their labour. These crown demesnes are to be carefully distinguished from the personal property of the reigning family, the annual rental of which may amount to L. 100,000 Sterling a-year.

Another branch of revenue is derived in Austria, as in France, from the exclusive manufacture and sale of tobacco. This monopoly extends over the German dominions, but Hungary and Transylvania are not subject to it. Austria has likewise a duty on stamps, hair powder, starch, and various objects of luxury, among others, on the *rouge* used by the fair sex. Wine, beer, brandy, carriages, pleasure horses, are all subjected to taxation. A considerable income is levied from legacy duties, fees on titles of nobility, china, glass, and even from a toleration tax on the Jews. The financial embarrassments of the country, necessitated, in 1802, an increase of a full third on these duties, along with the imposition of two taxes of a different kind—a poll and an income tax. This rapid augmentation of public burdens made it be calculated, that throughout the empire no less than a fourth of the income of individuals found its way into the public treasury. To compute the total of the revenue is a point of no small difficulty in a country where taxes are complicated, and official accounts either withheld or irregularly published; but we are disposed to think, that L. 18,000,000 Sterling may form a probable approximation to the *gross* revenue of this empire.

The Austrian, like other governments, has had recourse, in its distress, to the circulation of paper money,—a measure attended with all the bad consequences incidental to immoderate issues on the part of an authority not responsible to its subjects. The public debt exceeds 150 millions Sterling: two-thirds of which, however, being created by the issue of paper, are by no means deemed repayable at their nominal amount. In fact, the repayment of a fifth part of that amount, will be accounted a fair retribution of the debt contracted in this paper at an advanced stage of its depreciation. The rule at the treasury was to raise prices as paper fell, and the eventual adjustment of accounts between government and the stockholder will probably take place in a manner si-

imilar to that adopted in France after the death of Louis XIV., under the direction of the brothers Paris, when a regular scale of estimates was formed on a retrospect to the value of government paper at the different periods of its issue.

9. Agriculture is still in a very backward state throughout the Austrian dominions. The large proportion of church and other public lands, with the general want of education, have hitherto prevented the people from extracting an adequate return from their fertile territory. In casting the eye over these rich provinces, an observer is at a loss on which to fix as most favourable to the exertions of the husbandman. The uneven surface of the Hereditary States rivals, in point of fertility, the extensive plains of Hungary and Transylvania. Again, the portion of Poland, acquired by Austria, was perhaps the richest division of that ill-fated country. The following rough estimate has been made of the appropriation of respective proportions of the empire. Taking 70 as the integral, representing the whole surface, we shall have for

Mountains, heaths, marshes, lakes, roads,	26
Land under tillage,	12
Meadows and pasturage in an inclosed or improved state,	7
Pasturage in a rude state,	4
Woods and forests, comprising all uncleared tracts,	18
Vineyards and orchards,	3
	70

The produce of the land along the Danube, from Vienna to the Bavarian frontier, has been greatly increased within the last half century, by the use of marl. The traveller, in pursuing this tract, sees in all directions a quantity of marl pits, wrought with great activity. Bohemia is naturally fertile, but its agriculture is in a very backward state, from the continued prevalence of feudal usages. Moravia has made greater progress, and furnishes an annual supply of corn for export. Hungary is in many parts so fertile as to produce an abundant crop, with very little exertion from the labourer. Here may still be seen the primitive practice of treading out the corn by horses and oxen. Galicia, under a better system, might be rendered productive in the highest degree. The same holds in regard to the adjacent Polish province of Bukowine. Maize is cultivated in Hungary and Transylvania; millet in Hungary, Slavonia, and Carinthia; and even rice is found to answer in the marshy districts of Temeswar.

The product of the Vine, though far short of what it might be rendered, is a source of considerable wealth to Austria. The well known tokay is raised on the last chain of the Carpathian range, in the neighbourhood of the country of Zemplin. The district where it is cultivated is of the extent of 60 or 70 square miles; its qualities are various, the richest kind proceeding from the grape, with little or no pressure, while the inferior sorts are said to be made of the dried grape, reduced into a sort of pap, and mixed up with other Hungarian wines. We must not take for granted, that all the wine sold under the

Austria. name of tokay is the product of the district just mentioned. The dealers find this fashionable name a very convenient passport for the produce of the adjacent districts, so that even in Vienna there is not a tenth of real tokay among the wines sold under that designation.

Tobacco is cultivated to a great extent in Hungary and other parts of the empire. Hops are raised in Moravia and Hungary, but more particularly in Bohemia, where in some districts they are said to approach in quality to those of England.

The stock of horned cattle is said to have decreased of late years in the Austrian empire, in consequence of the introduction of large numbers of sheep. It has been computed, on a rough calculation, that the Austrian dominions comprise about two and a half millions head of cattle, above five millions of sheep, and about one million of horses. The Hungarian horses are small, but active, and capable of great fatigue. Many of them are accustomed, in their early years, to wander in a wild state along their vast pastures, and are caught only when of an age to become fit for service in the field. Galicia and Moravia contain a large proportion of the above mentioned number of horses. The remainder are chiefly in Lower Austria; for neither Bohemia, nor the mountainous tracts on the south of the Hereditary States, contain any considerable number. There are four public establishments for the purpose of training horses in Austria, the principal of which is at Mezaehgyes in Hungary. In this, unquestionably the greatest institution of the kind in Europe, there are no less than 800 mares, of German, Bessarabian, Moldavian, Spanish, or Hungarian extraction.

Mines and Manufactures.

10. Hungary and Transylvania possess mines both of gold and silver. They have also what is much more favourable to the increase of their productive industry, excellent mines of copper. The tin of Bohemia is compared to that of Cornwall, as the iron of Styria is to that of Sweden. These metallic treasures are not confined to a single province, but sufficiently scattered to diffuse the means of employment throughout various parts of the empire. Another mineral product of the highest importance is coal, which is found in various spots of Bohemia, Moravia, and Hungary. Thirty mines are already ascertained to exist in the latter country, although so backward is the application of capital to useful purposes, that only two of them are as yet wrought. In Bohemia, Styria, and Lower Austria, this important branch of industry has been somewhat more cultivated, in consequence of the vicinity of the coal to iron ore.

Mines of rock salt are found in various parts of the Empire. Those of Bochnia and Wieliecka in Galicia are known to be the greatest in Europe. A number of others are found along each side of the great Carpathian chain; nay, they extend, with greater or less intervals, all the way from Moldavia to Suabia, along a tract which, including a variety of windings, is not short of 2000 miles. This tract comprehends the salt mines of Wallachia, Transylvania, Galicia, Upper Hungary, Moldavia, Upper Austria, Styria, Salzburg, and finally of Tyrol. They are found either at the base or on the ascent of great mountains; the salt extending in horizontal or undulating strata, and alternating with strata of clay,

Austria. in which the saline substance is frequently observed to have made its way.

Manufactures have of late years been considerably on the increase throughout Austria. Few countries are more abundant in the supply of raw materials, and this substantial advantage received a powerful, though ill-judged, co-operation on the part of Joseph II., who thought it expedient to resort to a prohibition of several kinds of foreign manufactures. Linen and hemp may be called the staples of the Hereditary States and of Bohemia. Different qualities are fabricated in different places, Moravia having generally the coarse stuffs, while certain parts of Bohemia carry the fabric to a point of great nicety. The ruder provinces of Galicia, Hungary, and Transylvania, have made little progress in these branches of industry, or in the manufacture of cotton cloths, which is considerably diffused through Bohemia and the Austrian states. Spinning machines have been introduced from England, but the price of the raw material is necessarily enhanced by the distance of land carriage. Woollen cloths are made throughout the empire, particularly in Moravia, but the quality in the remote provinces is very inferior.

No country is better adapted to excel in hardware manufactures than Austria. The mines in Bohemia, Styria, Carinthia, and Upper Austria, supply an abundant store of excellent materials. The steel of Carinthia and Styria is known and highly prized in England. Vienna, Prague, and Karlsbad, contain manufactures of this metal, and arms are made in great abundance in more than a dozen of different towns. Glass has long been made in great quantities in Bohemia and the neighbouring provinces; but the long continuance of the late wars was unfavourable to the ornamental species of this manufacture.

The course of recent events has thus unexpectedly restored, and, in fact, more than restored, Austria to her high station among European potentates. The long continued exertions of Britain, the unsparing sacrifices of Russia, and, more than all, the extravagant attempts of Bonaparte, have redeemed the past errors of the cabinet of Vienna, and enabled her to reap the richest harvest of any of the allies from the spoils of the French empire. Her influence over the south of Germany is strengthened, and her ascendancy over Italy, formerly one of her weakest sides, is materially increased. The Low Countries, however rich and fertile, were at too great a distance from her other dominions, and too little connected with her by manners or national feeling, to form a first rate object of her policy. It is not too much to say, that the loss of them is fully compensated by the consolidation given to her Italian acquisitions by the incorporation of the Venetian States.

In the present state of France, there seems no likelihood of a renewal of a military contest with Austria, for many years. Italy is now doubly fortified against invasion; and the present generation of Frenchmen will listen to no enterprises of ambition beyond the Rhine. Austria may thus enjoy profound peace, if she be not deluded into projects of aggrandizement on the side of Turkey, or alarmed into a struggle with Russia on account of her possessions in Poland.

Concluding Observations.

Austria
Ayrshire. The writers upon Austrian Statistics are very numerous; but we shall content ourselves with referring in this place to the lately published and instruc-

tive Work of M. Marcel de Serres, entitled *Voyage en Autriche, ou Essai statistique et géographique sur cet Empire*. Paris, 1814. 4 vols. 8vo. (D. D.)

Austria
Ayrshire.

Situation. AYRSHIRE, a county in the west of Scotland, considerable for its population and industry, is bounded by Wigtonshire and the stewartry of Kirkcudbright on the south, by the counties of Dumfries and Lanark on the north-east and east, by Renfrewshire on the north, and by the Irish Sea and the Frith of Clyde for about 70 miles on the west. It contains about 1039 square miles, or 664,960 English acres, of which nearly the half is under cultivation; besides several small lakes, Loch Doon being the largest, extending to about six square miles more. The three bailiaries of Kyle, Cunningham, and Carrick, into which this county is divided, have been described in the article in the body of the work, to which the reader is referred. The rock of Ailsa, and the Meikle and Little Cumbræ, situate from $1\frac{1}{2}$ to 3 miles from the coast of Ayrshire, and nearly the same distance from the Isle of Bute, are attached to this county. (See **HEBRIDES**.)

Extent. The valued rent is L. 191,605, 7d. Scots, and the real rent in 1811, of the lands, was L. 336,471, 10s. and of the houses, L. 22,823 Sterling. The division of property is considered not unfavourable to the prosperity of the different classes of the population, though it appears that more than a third part of the whole county is held under settlements of entail. The advantages possessed by Ayrshire, besides its sea-coast and several excellent harbours, may be traced to the coal and limestone found in great abundance in almost every part of it,—the one so necessary to its manufactures, and the other to its agriculture; and the chief natural disadvantage under which it labours is the humidity of its climate, aggravated by the quality of the greater part of the soil, which is a tenacious clay.

Valued and real Rent.

Soil and Climate.

Agriculture. Agriculture, according to the more approved courses of management, has nevertheless made considerable progress of late in this county. The old rotation of three consecutive crops of corn, followed by six years hay and pasture, has been very generally abandoned in the new leases; and, on the better soils, an alternation of white and green crops, and an interchange of tillage and pasturage, as in the eastern counties of Scotland, begin to prevail. The dairy is, however, the chief object of attention to the Ayrshire husbandmen, and their valuable breed of cows, and rich, yet mild cheese, known by the name of Dunlop cheese, are in great repute in most parts of Britain. Their horses, under the general name of Clydesdale or Lanarkshire horses, are equal, if not superior, to those of any other race in the Island; almost every small farmer, and the farms are too generally small, either rearing one or more himself, or purchasing them when young, and reselling them to the eastern counties after a year or two of very moderate labour. After all, it must be admitted that the agriculture of Ayrshire is much behind that of the counties on the east coast. No regular system of cleansing and manuring the soil, nor of fallowing and draining the wet lands, is to be seen throughout

the greater part of the district. The size of the farms is commonly from 50 to 150 acres, affording little room for the employment of capital, or the division of labour; and yet the rents are surprisingly high—of some favoured spots not less than eight pounds or guineas the acre.

Ayrshire, as a manufacturing district, seems to stand next in importance, among the Scottish counties, to the contiguous shires of Lanark and Renfrew. Various branches of the woollen manufacture are carried on to a considerable extent in different parts of it, in Kilmarnock alone, to the value of L. 30,000 yearly. Carpets, and the coarser fabrics, give employment to a considerable proportion of the inhabitants of that thriving town; and besides several public establishments there, and in other parts of the county, many private families in almost every parish take a share in the manufacture of blankets and coarse cloths; a part of which, after supplying their own wants, is carried to the fairs and markets of the county. Beith has long been noted for its thread manufacture. The cotton-works at Catrine are by far the most extensive of all its manufactories; employing, in 1811, 900 hands, who are said to have spun into yarn 10,000 lbs. of cotton wool, and made 35,000 yards of cloth every week. At Muirkirk and Glenbuck, pig and bar iron are wrought to a great extent, and founderies have been erected there and in other places. Leather, saddlery, earthen-ware, kelp, salt, are the only other kinds of manufacture worthy of notice in this county.

Ayr, Irvine, and Saltcoats, were, till very lately, the only harbours much frequented, and at these places there has long been a little trade with Ireland, America, and the Baltic, and a considerable trade coastwise. In 1807, the port of Ayr had 54 vessels, of which the burden was from 4000 to 5000 tons, and 82 vessels belonged to Irvine and Saltcoats, which carried 6795 tons. Coal is the staple article of export, and corn the most considerable of its imports; the ports on the Clyde having hitherto been the grand emporium of the west of Scotland.

This county exhibits instances of public spirit in its great land proprietors beyond any other in Scotland, or probably in the British empire. The harbour, and other works carrying on at Ardrossan, under the auspices of the Earl of Eglinton, and the harbour of Troon, and the railway from thence to Kilmarnock, formed almost entirely at the expence of the Duke of Portland, are worthy monuments, no less of the enlightened judgment and energy, than of the wealth of these two patriotic noblemen; and the distant prospect of remuneration, which it is much to be wished should be realized, can detract but little from the merit of such grand and princely undertakings.

The harbour of Ardrossan will, when completed, be one of the safest, most capacious, and most accessible on the west coast of Britain; possessing many advantages over the harbours in the Frith

Ayrshire. of Clyde, situate in a narrow channel, which can be navigated only when the wind blows from particular points, and which, for upwards of 20 miles below Glasgow, is both shallow and dangerous. A circular pier of 900 yards was finished in 1811, and everything was then ready to begin the wet-dock, which, according to Mr Telford's plan, was to contain from 70 to 100 vessels in water 16 feet deep. The works have rather languished of late, and are not likely to be completed soon without public aid. It was part of the Earl of Eglinton's plan to raise a neat regular built town at Ardrossan, in which some progress has been made; and he has constructed excellent baths, which draw to it a number of visitors at the proper season.

The harbour at Ardrossan was only a part of the general plan, and that from which, viewed by itself, the smallest advantages perhaps were to be expected. The leading idea was to open up a direct communication between Glasgow, Paisley, and other large towns in the vicinity, and the west coast, instead of the present circuitous passage by the Frith of Clyde. A canal was therefore to be cut from Glasgow to Ardrossan, about 31½ miles, at the estimated expence of L.125,000. Of this only a third has been yet executed, that is, from Glasgow to Johnstone, and this part has cost about L.90,000.

Canal.

Troon Harbour.

The harbour at Troon, connected as it now is with Kilmarnock, by means of an excellent railway, seems to possess almost all the advantages of that of Ardrossan, and promises to become, in a much shorter period, of vast utility both to the populous country around it, and to the noble under-

taker. The pier is now carried into the sea more than 200 yards, and it is proposed to extend it 100 yards farther. At the present extremity, there is a depth of 17 feet at low water. One graving dock was finished about three years ago, which is much resorted to for the repair of coasting vessels; and another, 37 feet wide at the gate, is nearly completed, which will admit vessels of almost any burthen. Extensive warehouses have been erected; and a yard has been opened for building vessels, which is likely to be well employed.

Ayrshire.

The railway from Troon to Kilmarnock, a distance of 10 miles, is now completed, and answers all the purposes for which it was originally intended. There are upwards of 3000 acres of coal fields in its course, which must in time indemnify the Duke of Portland for his outlay both on this and the harbour. Coals have been hitherto the principal article of conveyance towards the Troon, at the rate of 100 tons daily; and from thence timber, iron, grain, &c. are transported to Kilmarnock and the country adjacent. One horse draws with ease five tons downwards to the Troon, and three tons upwards to Kilmarnock. But locomotive engines, upon the principle of Mr Stephenson of Newcastle, promise soon to render horses unnecessary. The machine weighs 3½ tons, and can carry along with it 25 tons, at the rate of four miles an hour upon an average. This railway has cost the Duke upwards of L. 50,000, and the harbour is estimated at about the same sum.

The comparative population of Ayrshire, as taken under the acts 1800 and 1811, will be seen from the following abstract:

1800.

DISTRICTS.	HOUSES.			OCCUPATIONS.			PERSONS.		
	Inhabited.	By how many Families occupied.	Uninhabited.	Persons chiefly employed in Agriculture.	Persons chiefly employed in Trade, Manufactures, or Handicraft.	All other Persons not comprised in the two preceding classes.	Males.	Females.	Total of Persons.
Carrick	2608	2900	69	7588	4023	2141	6640	7112	13,752
Cunninghame	5618	8050	85	12,220	22,440	2582	17,165	20,027	37,192
Kyle	5382	7193	118	13,377	15,582	4067	15,861	17,501	33,362
	18,608	18,143	272	33,185	42,045	8760	39,666	44,640	84,306

1811.

DISTRICTS.	HOUSES.			OCCUPATIONS.			PERSONS.		
	Inhabited.	By how many Families occupied.	Building and uninhabited.	Families chiefly employed in Agriculture.	Families chiefly employed in Trade, Manufactures, or Handicraft.	All other Families not comprised in the two preceding classes.	Males.	Females.	Total of Persons.
Carrick	2997	3450	132	1474	1935	641	7665	8557	16,222
Cunninghame	6206	10,167	138	1725	6183	2309	21,390	24,737	46,127
Kyle	6204	7877	192	2186	3886	1805	19,451	22,154	41,605
	15,407	21,494	462	5385	11,354	4755	48,506	55,448	103,954

(A.)

Azores. **AZORES, or WESTERN ISLANDS.** These form a range situate in the Atlantic Ocean, extending in an oblique line from north-west to south-east, between the 37th and 40th degrees of north latitude, and the 25th and 32d degrees of west longitude. It has been a subject of some controversy among geographers, to what quarter of the world they ought to be referred. Originally attached to Africa, they were afterwards, with evident impropriety, transferred to America, and are now more generally viewed as part of Europe; though their connection and general resemblance to the other African groups, rather incline us to adhere to the first arrangement.

It does not appear that the ancients had any knowledge of the Azores, or of any group in this sea, except the Canaries, to which they finally applied the celebrated appellation of the Fortunate Islands. But the Arabian geographers, Edrisi and Ibn al Vardi, describe, after the Canaries, nine other Islands, situate in the Western Ocean. That these were the Azores is rendered highly probable, by considering, that their number is exactly nine; and that mention is made by these writers of the abundance of a species of eagle or hawk, a circumstance which afterwards appeared to the Portuguese so remarkable, that they derived the name of the Islands from it. The climate in which they are placed also makes them north of the Canaries. Some other coincidences might be pointed out, did our limits permit; and, upon the whole, we see no reason to doubt, that the Azores are really the nine Islands enumerated by the Arabians; though two of the number might probably be Madeira and Porto Santo, while the small Islands of Corvo and Flores might remain unnoticed. The Arabian writers represent them to have been populous, and to have contained cities of some magnitude; but state, that the inhabitants had been greatly reduced by intestine warfare.

The first European discovery of this group is claimed by the Flemings. The Portuguese, eagerly bent upon pursuing their career of navigation along the coast of Africa, did not readily turn into any other direction. A Flemish merchant, called Van der Berg, is reported, in sailing from Lisbon, to have been driven upon these shores. The intelligence soon reached the court of Lisbon, where it excited considerable interest. It is even said that Prince Henry went in person to examine the value of this new discovery. The Islands began, in 1459, to be planted and colonized; and in so fertile a soil, the inhabitants rapidly multiplied. In 1466, Alphonzo V. is said to have granted them to his sister the Duchess of Burgundy; though, in that case, they must have soon reverted to the Portuguese crown. In 1580, they fell, with the other Portuguese territories, under the dominion of Spain. The Azores were at this time the grand rendezvous, in the voyage homewards, of the fleets, which came laden with the wealth of both the Indies. Hence they became a theatre of that maritime warfare, which was carried on with such spirit by the English under Queen Elizabeth against the peninsular powers. In 1586, Sir Walter Raleigh equipped two pinnaces of 35 and 40 tons, the command of which he gave

to Captain Whiddon. Having taken two or three prizes, they fell in, off St Michael's, with the great fleet of Spanish galleons, consisting of twenty-four sail, two of them caraks of 1000 or 1200 tons. They attacked them, however, without hesitation, hoping to cut off some straggling member of this great body. It will not surprise our readers, that they were unable to make any impression upon it; but they retired without loss. In 1587, Sir Francis Drake, after having swept the harbour of Cadiz, sailed for the Azores, where he took an East India carak, richly laden, and the first that had ever fallen into the hands of the English. In 1589, the Earl of Cumberland fitted out a squadron, sailed for the Azores, and made numerous prizes.

Under the active administration of Pombal, considerable exertions were made for the improvement of the Azores; but the stupid and bigoted government which followed, rather tended to destroy these benefits, and to make the Islands take a retrograde course.

In giving a description of these Islands, we shall ^{St Michael.} begin with St Michael, the largest and most populous, and the one in which the peculiar physical structure of the Azores is exhibited on the greatest scale. St Michael consists generally of a fertile plain, but diversified by an infinite variety of hills and mountains, all bearing evident marks of volcanic action. The centre of the Island contains chiefly small conic hills; but the east and west quarters rise into lofty mountains, with deep valleys and lakes intervening. The face of the country is almost everywhere smiling; the plains are covered with luxuriant crops; vines and oranges grow on the hills; and even the mountains are adorned with myrtles, laurels, and other evergreen shrubs. All appears a paradise; nor could the observer, at first, suspect that this was a spot chosen, as it were, by nature for the display of all her most terrible phenomena. The form of the mountains, however, soon indicates their history. There are few, which, after being moulded by the volcano, have not been rent by the earthquake. In some cases, the chasm is so complete, that a level path has been formed between the severed members. One of the most remarkable appearance of this kind occurs in the Porto do Ilheo, a small Island about a quarter of a mile from the harbour of Villa Franca. Here a volcanic rock, 2000 feet high, has been completely split, exhibiting a chasm 39 feet wide, from the top to seven feet below the surface of the water. It forms thus, for a few small vessels, a harbour, perfectly safe from every vicissitude of the weather.

In the year 1591, there appears to have been a most tremendous earthquake felt all over the Azores, but which shook St Michael for twelve days without intermission. Since that period, there is no record of any such great convulsion, except one in 1757, of which we have no particulars, and it was probably much less formidable; nor are any of its volcanoes at present in a state of action. Hot springs abound in every part of the Island; and from almost every crevice, vapour is seen issuing. But the most remarkable phenomena are the Caldeiras, or boiling fountains,

Azores.

which rise chiefly from a valley called the Furnas, near the western extremity of the Island. The water ascends in columns, to the height of about twelve feet, after which it dissolves in vapour, forming clouds of various shapes and colours. The heat is such as to boil an egg in two minutes; though the sulphureous impregnation unfits it for being employed in such purposes. The ground in the immediate vicinity is entirely covered with native sulphur, like hoar frost. At a small distance is a remarkable phenomenon, called the Muddy Crater, whose vertex, of forty-five feet diameter, is on a level with the plain. Its contents are in a state of violent and continual ebullition, accompanied with a sound resembling the waves of a tempestuous ocean. Yet it never rises above its level, unless occasionally to throw to a small distance a spray of the consistence of melted lead. The Furnas abound also in hot springs; some of which it is impossible to touch without being scalded. There is almost always, however, a cold spring near the hot one, so that they can be brought to any temperature that may be desired. These springs, after being long neglected, have, within the last half century, been greatly resorted to, and the cures performed in cases of palsy, rheumatism, and similar maladies, are said to be very wonderful.

St Michael is about 50 miles in length, and varies in breadth from 5 to 12 miles. The plains are fertile in wheat, barley, and Indian corn; while vines and oranges grow luxuriantly on the sides of the mountains. They are made to spring even from the interstices of the volcanic rocks, which are sometimes blasted in order that they may receive the plants. Raised in this manner, they are said to be of superior quality; but the great expence originally required in such a mode of cultivation, confines it to persons of some capital. The western part of the Island yields hemp, which might be raised to a considerable extent. There is also a mountain called *Pico de fer*, which appears to be rich in iron, though no means are at present employed for extracting the ore from it. The exports consist of wine, fruit, and provisions. Foreign intercourse used to be confined rigorously to Lisbon; but since the emigration of the court, the inhabitants have assumed the privilege of trafficking directly with England, America, and other countries. After defraying the expence of its local government, it yields L.28,000 of revenue to the mother country.

The principal town in the Island is Ponta del Gada, which contains about 12,000 inhabitants. It is built with tolerable regularity, the streets being straight and broad: the religious edifices are numerous and elegant. They consist of two large convents of the orders of St Francis and St Augustin, four convents for professed nuns, and three recolhimentos for such as are not professed. The harbour receives only small vessels. Those of any magnitude must anchor in an open road, which, though not dangerous, cannot be kept during the prevalence of southerly gales. It is, however, the best roadstead in the Island. Ribeira Grande is also a large town on the south coast, containing nearly as many inhabitants as Ponta del Gada. It has two large convents, and there

Azores.

are several warm springs situate in its neighbourhood. Villa Franca, also, though nearly destroyed by the earthquake of 1591, is now a considerable city. Alagoa, Agoa de Pao, Porto Fermoza, and a few others, are also of some magnitude. The whole number of inhabitants in the Island is estimated at 80,000 or 90,000. The character of the people appears to be hospitable, but indolent and luxurious, and they are entirely under the dominion of the priesthood.

St Mary is a small Island immediately adjacent to St Mary. St Michael's, through the medium of which its trade is conducted, as it has no good harbours of its own. It produces wheat in abundance, and exports a considerable quantity. The soil is composed of clay, which is partly manufactured into pottery.

Tercera, though smaller than St Michael, being Tercera. placed in a more central position with respect to the other Islands, has been chosen as the seat of Government. The port of Angra is also superior to any of those in St Michael. This Island does not exhibit nearly the same extensive traces of volcanic action: the summits of its mountains are generally level. It is represented by Adanson, however, as entirely composed of volcanic products. Its lava, he says, is of a thicker grain than that of Teneriffe. It abounds in grain and cattle; but its wines are inferior, and its fruits raised merely for internal consumption. The residence of the Government renders the society somewhat superior to that which is found in the other Islands. The number of inhabitants is estimated at 50,000.

Fayal is the most frequented of all the Islands, as Fayal. its harbour is the best in the Azores, and it lies directly in the track of vessels that are crossing the Atlantic in any direction. The principal town is called Villa de Horta. Captain Cook observes, that all sorts of fresh provisions may be got here; the bullocks and hogs good, but the sheep small and wretchedly poor. The town is defended by two castles and a wall, both in decay, and serving rather for show than strength. The city contains two convents for monks, and three for nuns, with eight churches. These are the only good buildings in it; no other having glass windows. The bay is two miles in length, and three quarters of a mile in breadth, the depth of water from six to twenty fathoms. Though a good road, it is not altogether free from danger in SSW. and SE. winds.

A considerable quantity of wine is exported from Pico. this place, under the appellation of Fayal wine; but it is really the produce of Pico, one of the most remarkable of the Azores. This Island is composed of an immense conical mountain, rising to the height of 7000 feet, and bearing every trace of volcanic formation. The soil consists entirely of pulverized lava, and the ground has even been said to sound hollow when struck. All the lower parts of the mountain are in the highest state of cultivation, and covered with vine and orange plantations. The wine annually exported amounts to about 5000 pipes. It forms a sort of inferior Madeira, which, selling 50 per cent. cheaper, is in considerable demand. Pico produces also a valuable species of wood, resembling, and equal in quality to, mahogany.

Graciosa and St George are two small Islands, si- Graciosa and St George.

Azores
||
Babylon.

tuated between Fayal and Terceira. Graciosa is chiefly noted for the extreme beauty of its aspect and scenery. St George has recently been exposed to one of those awful visitations to which the Azores are subject. In 1808 a caldeira, situate in the centre of the Island, was observed to be in a state of violent fermentation. It continued, during several days, to emit subterraneous noises, and to cause violent convulsions through every part of the Island. At length the great crisis came; vast streams of fire issued forth in every direction, with clouds of smoke, which, but for the volcanic light, would have involved every thing in midnight darkness. The principal stream took its direction towards the beautiful town of Ursula, which it seemed on the point of swallowing up; but suddenly changing its direction, rushed into the sea by a different channel,—a happy event, which superstition ascribed to the prayers of the Ursuline nuns. Many hundred acres of fertile land, however, were covered with scorice and ashes; some lives were lost, and a general gloom and consternation diffused throughout the Island. The inhabitants, however, showed no disposition to emigrate, and soon applied themselves to repair the damages which their Island had sustained.

Corvo and
Flores.

The two small and most westerly Islands of Corvo and Flores, seem but imperfectly to belong to the group. They lie also out of the usual tract of navigators; but to those who, missing their course, are led thither, Flores affords good shelter in its numerous bays. Its poultry is said to be the finest in the world; the cattle are numerous, but small. The surplus produce of these Islands is not of much importance.

It would be improper to close this notice without mentioning one of the most striking occurrences in nature, sometimes exhibited in this quarter—the sudden emersion of new Islands from the bosom of the ocean. The first relation of such an event is given by Kircher in his *Mundus Subterraneus*. He describes it as announced by violent earthquakes, which lasted for eight days; then a fire broke from the surface of the sea, and rose to the clouds; while vast quantities of stones, earth, sand, and minerals, were at the same time vomited out. At length a

group of rocks burst forth, which gradually increased till they covered several miles in circumference, and, after being shattered by a new earthquake, settled at length into a solid consistence.

A narrative of a similar phenomenon is given in the 32d Volume of the *Philosophical Transactions*. John Robison, master of a small vessel, is stated to have arrived on the 10th December 1720, at Terceira, “near which Island he saw a fire break out of the sea.” On his arrival at Angra, the governor hired his vessel, for the purpose of going to view it. “On the 19th,” says he, “at two afternoon, we made an Island all fire and smoke. The ashes fell on our deck like hail and snow. The fire and smoke roared like thunder or great guns.” He adds, that quantities of pumice stone (probably common lava), and of half-broiled fish, were found floating on the sea in its vicinity.

A similar phenomenon took place in February 1811, about half a league from the western extremity of the Island of St Michael. It seems to have been attended with nearly the usual symptoms; fire bursting from the sea, and ascending into the air like a host of sky-rockets, accompanied with vast volumes of smoke, and showers of scorice and lava. The rocks, however, did not rise above the surface of the water, but appeared immediately under it, with the waves dashing furiously round them. The previous soundings are said to have been eighty fathoms.

On taking a general view of these phenomena, and of the other peculiarities of the Azores, it is impossible not to lament that they should not yet have been surveyed by any scientific observer; and we would fain entertain the hope, that some traveller, properly qualified, may at length be induced to turn his attention to a group of Islands, which, more than any other, seems to offer a rich field of observation and discovery to geologists and naturalists in general.

See *Hartmann's Edrisi*.—*Voyages des Hollandois*, T. I.—*Astley's Collection*, Vol. I.—*Masson's Account of St Miguel* (in *Phil. Trans.* 1778).—*Cook's Second Voyage*.—*Adanson's Voyage to Senegal*.—*History of the Azores*, London, 1813. (B.)

B A B

BABYLON.—Under this head, in the body of the work, will be found a full account of the extent of ancient Babylon, and of the stupendous edifices, which rendered it the wonder of mankind. Our present object will be, to collect, from recent information, the vestiges which, after so long a succession of ages, still remain, of this celebrated capital of the East.

Among all the remains of ancient grandeur, there

are none perhaps which possess equal interest with the ruins of Babylon: none which present so many striking images to the imagination, or carry back the mind into such a depth of antiquity. It happens fortunately that their site, through the learned investigations of Major Rennell, may be considered as completely fixed to the small district, situate immediately to the north of the village called Hellah.* Its po-

* Hellah is nine miles from Mohawil, and nearly forty-eight from Bagdad. *Rich's Memoir on Babylon*.

Babylon. sition on the Euphrates, the fountains of bitumen at Hit or Heet, the distance from the ascertained position of Seleucia and Ctesphion, and the character of the surrounding country, combine in establishing this point beyond a doubt. The appellation *ruins*, in its proper sense, cannot, however, be applied to the present remains of Babylon, which consist almost wholly of bricks, fragments, and rubbish, piled, as it were, in masses, and serving as quarries for the construction of new cities. In this condition, nevertheless, they have deservedly attracted the attention of modern travellers; and interesting notices have been given by Della Valle, Niebuhr, Ives, Otter, and Beauchamp. But the recent observations of Mr Rich, enlightened by the previous inquiries of Major Rennell, have been so much more careful and complete, that they nearly supersede all prior information. We shall first give a view of the objects that presented themselves to Mr Rich, in traversing this celebrated ground, and shall then offer some remarks as to those ancient edifices, of which these objects are to be considered the remains.

Mr Rich commenced his observations at Hellah, and proceeded to the north, along the eastern bank of the Euphrates. After passing some smaller mounds, he came to a vast mass, 1100 yards in length, and 800 in its greatest breadth; while its most elevated part rose 50 or 60 feet above the level of the plain. It consists almost wholly of earth formed from decomposed brick, and strewed with various species of fragments. The name of Amran is given to it from a tradition, seemingly unfounded, of a son of Ali having been buried in it.—Then, after traversing a valley 550 yards long, and crossed by some smaller ruins, he came to the second grand mass, forming nearly a square of 700 yards in length and breadth. This part of the ruins is extremely interesting, containing several walls, in a pretty entire state; they are eight feet thick, in some places ornamented with niches, in others strengthened by pilasters and buttresses. Some remains of painting and sculpture are to be seen on them. The bricks are of the finest kind, and cemented with lime. We may here observe that the city, as Major Rennell suspected, appears to have been built, partly of burnt and partly of unburnt bricks. Three kinds of cement have also been used. The unburnt bricks are in general merely bound together with reeds or chopped straw, which are still found in great quantities. The burnt bricks are cemented, partly with bitumen, but more frequently with lime; a material, the use of which had escaped the notice of observers previous to Mr Rich. He states it to be much the most efficacious of any. Bricks cemented with bitumen could be easily separated; but where good mortar had been used, no power or art could detach them from the wall, without breaking them in pieces. Some parts of the edifice in question have been deeply excavated, with a view to the removal of the bricks; but the workmen have been intimidated, in consequence of the rubbish having fallen in, and buried some of their number; and they have given up the walls, on account of the extreme tenacity with which they are cemented. This edifice is called by the natives the *Kasr* or palace.

Babylon. A mile to the north of the Kasr, and about half a mile from the river, is a mass equally remarkable. It is an irregular oblong, the sides being respectively 200, 219, 182, and 136 yards in length; the greatest elevation 141 feet. Near the summit of the western side appears a low wall, built of unburnt bricks, cemented with reeds and straw. The summit is covered with heaps of rubbish, and with innumerable fragments of pottery, brick, bitumen, pebbles, vitrified brick, and even shells, bits of glass, and mother of pearl. There are many dens of wild beasts in this part of the ruins, and most of the cavities are filled with bats and owls. As there appeared a niche or recess near the summit of the northern face, Mr Rich caused it to be dug into. The workmen successively extracted two wooden coffins, containing skeletons in high preservation. He was of opinion that the whole passage, whatever might be its extent, would have proved to be occupied in the same manner.

This mass, denominated the *Mujelibé*, being the most elevated part of these remains, has been considered by most travellers as the Tower of Belus, which formed one of the two grand features in the wonders of ancient Babylon. The other was the Palace, with its hanging gardens; and this was clearly pointed out, by ancient authorities, to be on the side opposite to the tower of Belus. The tower then being on the eastern, the palace was to be sought on the western bank of the river. With the exception, however, of a slight notice, collected by D'Anville, modern travellers had given no information of any ruins situate in that quarter. Major Rennell very properly pointed out this as a grand object of investigation for future inquirers. Mr Rich, on reaching the summit of the *Mujelibé*, whence he commanded an extensive view across the river, was much surprised at discovering no trace of any ruins whatever. Not satisfied with this distant view, he crossed and carefully surveyed the ground, but could discern only some mounds of small dimensions, which conveyed no idea of the immense structures of which he was in search. Before leaving this neighbourhood, however, he went to visit a tower, which had been imperfectly observed by Niebuhr, about six miles south-west of Hellah, and beyond the site assigned to ancient Babylon. Our traveller, who had formed no high expectations from this object, was struck with the utmost amazement at its magnitude and grandeur, which decidedly surpassed any thing he had yet witnessed among these interesting remains. It consists of a mound of an oblong figure, 762 yards in circumference. It rises in a conical form to the height of 198 feet, and has on its summit a solid pile of brick 37 feet high, diminishing in thickness to the top. The bricks are of the finest description, with inscriptions on them, and so well cemented with lime, that it is nearly impossible to extract one of them entire. This ruin is called by the Arabs the *Birs Nimrod*. Every thing remarkable is by them ascribed to Nimrod; but the meaning of the term *Birs* seems unknown even to themselves. By the Jews it is called Nebuchadnezzar's Prison. At a trifling distance to the east is a mound equal in elevation to the Kasr; and

Babylon. all around are traces of ruins to a considerable extent.

Mr Rich having thus described these ruins, begins very cautiously to form conjectures respecting their origin and nature. At the first sight of the *Birs Nimrod*, he had involuntarily exclaimed that, if the situation rendered it possible, this certainly must be the tower of Belus. Besides its extraordinary magnitude, there is some appearance of its being built in stages, as described by ancient authors; and the mound on the east may correspond to the temple, which occupied part of the quadrangular inclosure that surrounded the tower. After considering these circumstances, Mr Rich is led on to inquire, whether it be so certain as is generally supposed, that the tower of Belus must be found on the eastern side of the river, and the palace and hanging gardens on the western. But after some acute remarks, his path becomes entangled, and he is obliged to stop, without arriving at any satisfactory appropriation of the objects which had fallen under his observation. The subject is certainly involved in much darkness and uncertainty; but as it is of considerable interest, we shall present our readers with such observations as its consideration has suggested to us.

It is stated by ancient writers, in the most positive and circumstantial manner, that the palace, with its grand appendage of hanging gardens, was situate upon, or very near to the river; whence, indeed, the gardens were artificially watered. Now, modern Babylon presents, near to the river, no ruins of any magnitude, except those on its eastern bank; the Amran, Kasr, and Mujelibé. It seems unquestionable, therefore, that these, if any, must be the remnant of those immense structures. Then, following Herodotus, we must look for the tower of Belus on the western side of the river. But here we are crossed by the statement of Diodorus, to which Mr Rich does not seem to have fully adverted. That author reports, that there were *two* palaces built on opposite sides of the Euphrates; of which by far the most extensive and magnificent was that on the western bank. This Major Rennell naturally infers to be the one which other writers call *the palace*. But it deserves notice, that Diodorus is the only authority for there being *two* palaces. Herodotus and Curtius, the former an eye witness, mention only one, and evidently entertain no idea that any more existed. It seems also quite unaccountable, that, while inferior structures exhibit vast piles of ruins, this western palace, which must have been the grandest and most extensive of all, should not have left the slightest trace of its existence. It may therefore deserve consideration, whether Diodorus, who wrote only from hearsay, might not have been deceived by varying accounts of one palace, into the idea that there were *two*. The striking similarity in his two descriptions, as to situation, plan, and ornament, somewhat favours the conjecture. We are sensible that it is a bold one; but can only say, that, without it, the aspect of modern Babylon is wholly inexplicable; for it seems quite ascertained, that there are no ruins of any magnitude, close to the river, unless on one side, which is the eastern.

It may not be amiss, therefore, to follow out the supposition, and to inquire how far, by its aid, the ancient and the recent descriptions can be brought to accord.

Ancient Babylon consisted of an immense square, divided by the Euphrates into two nearly equal parts. It is distinctly stated by Herodotus, that the palace and tower were in opposite divisions to each other. If, then, the ruins on the eastern side be the palace, we must look to the western for the tower. There we find the *Birs Nimrod*, a stupendous pile, the dimensions and character of which are precisely such as the tower, in a state of total dilapidation, might have been expected to exhibit. Yet, to its really being the remains of that edifice, the objections are formidable. First, its distance of nearly ten miles from the Mujelibé would, to include it within the city, require an extension even of the vast limits assigned by Major Rennell. But it is certain, that the extent of Babylon was immense; that it rather resembled an inclosed district than a city. A great part of its area was under cultivation; and it has even been asserted, that the produce raised within the walls could, in case of siege, support its immense population. Without resting on the authority of Herodotus, though it be confirmed by Pliny, even the dimensions of Strabo, reckoned according to his own estimate of the stadium, would give upwards of eleven miles to each side of the square. But it is supposed that the palace and tower must each be in the centre of their respective divisions; an arrangement certainly incompatible with the actual situation of the ruins. The expression of Herodotus, no doubt, is *ἐν μέσῳ*, in the *middle*; which Major Rennell has translated *centre*. We doubt much, however, if this expression can be understood in so precise and mathematical a sense. It is familiarly said, that a building is in the middle or heart of a city, when it is completely inclosed within it, and surrounded by its buildings, even though it may approach to one of its extremities. Such, it appears to us, might be the present meaning, especially since the palace, being upon the river, could not, geometrically speaking, be in the middle of its division. The Kasr above described seems pretty exactly what we should expect in the ornamented and inhabited part of the palace. The Mujelibé, Mr Rich conceives, might be the hanging gardens. We would suggest the mound of Amran as a more probable situation, from its vicinity both to the river and to the palace, while the Mujelibé is at an inconvenient distance from both. This last structure, from Mr Rich's observations, seems decidedly to suggest the idea of a royal sepulchre. Of such structures, several are mentioned in Babylonish history, particularly that of Ninus, said to have been built *within* the palace, and of extraordinary elevation. (Diod. l. ii. 7.)

Mr Rich mentions his intention of making repeated visits to this spot, and of examining the different objects with greater care and minuteness. Additional light may thus certainly be thrown upon the subject, though it seems improbable, after the surveys already made, that any grand feature should remain to be

Babylon
Bacon.

discovered. See *Memoir on the Ruins of Babylon*, by Claudius James Rich, Esq. 8vo. Lond. 1815. (B.)

BACON (JOHN), Academician, born 24th November 1740, who may be considered as the founder of the British School of Sculpture, and whose works are still its greatest boast, was the son of Thomas Bacon, cloth-worker in Southwark, whose forefathers possessed a considerable estate in Somersetshire.

At the age of 14, he was bound apprentice in Mr Crispe's manufactory of porcelain at Lambeth; where he was at first employed in painting the small ornamental pieces of china, but soon attained the distinction of being modeller to the work. The produce of his labour was devoted by him, from his earliest years, towards the support of his parents. While thus engaged, he had an opportunity of seeing the models executed by different sculptors of eminence, which were sent to be burned at an adjoining pottery. An observation of these productions appears to have immediately determined the direction of his genius; and his progress in the imitation of them was no less rapid than his propensity to the pursuit was strong. His ardour and unremitting diligence are best proved by the fact, that the highest premiums given by the Society for the Encouragement of Arts, in those particular classes in which he was a competitor, were adjudged to him nine times between the years 1763 and 1776. During his apprenticeship, he likewise formed the design of working statues in artificial stone, which he afterwards carried to perfection.

Mr Bacon first attempted working in marble about the year 1763; and, during the course of his early efforts in this art, was led, by the resources of his genius, to improve the method of transferring the form of the model to the marble (technically called *getting out the points*), by the invention of a more perfect instrument for this purpose, and which has been since adopted by many sculptors, both in this and other countries.* The advantages which this instrument possesses above those formerly employed, are, its greater certainty and exactness, that it takes a correct measurement in every direction, is contained in so small a compass as not to encumber the workman, and is transferable either to the model or the marble, as may be required, without the necessity of a separate instrument for each.

In the year 1769, the first gold medal given by the Royal Academy was adjudged to Bacon; and in 1770, he was associated by that body. His first work in sculpture was a bust of his present Majesty, George the Third, intended for Christ Church College, Oxford. It is said, that of sixteen different competitions in which he engaged with other artists, he was unsuccessful in one case only. His knowledge of the antique style was for a time called in question; and on occasion of the doubts which were raised on this point, he is reported to have modelled his head of Jupiter Tonans, as the most satisfactory method of repelling the charge. The objection probably originated from the circumstance, that in some

of his principal works the figures were represented in the costume of modern times; of which his statue of Justice Blackstone at All Souls College, Oxford, and that of Howard in St Paul's Cathedral, are remarkable examples. But his genius was not subjected to the trammels of this or any one style exclusively. Many of his emblematical figures are designed after the purest models, and in a taste altogether classical. Among others of this character, the monument to Mrs Draper, in the Cathedral of Bristol, is exquisitely simple. In his later productions, likewise, particularly those of a monumental kind, he introduced frequent examples of the ancient style: as in the well known monument to the Earl of Chatham in Westminster Abbey, that to Lord Robert Manners, and others which might be mentioned. "Another marble, scarcely finished at the time of his death," says Dallaway, in his *Anecdotes of the Arts in England*, "will secure him a lasting fame for originality and classical taste. It is the Coenotaph lately erected at Westminster Abbey to the poet Mason. A muse, holding his profile on a medallion, reclines on an antique altar, on which are sculptured, in relief, a lyre, the tragic masque, and laurel wreath; all of the most correct form, as seen on ancient sarcophagi of the pure ages."

On the 4th of August 1779, Mr Bacon was suddenly attacked with an inflammation of the bowels, which occasioned his death in little more than two days. He died in his 59th year, leaving a widow, his second wife, and a family of six sons and three daughters.

Of his merit as a statuary, the universal and established reputation of his works has afforded the decisive proof. "The works of Bacon, Bankes, Nollekins, Wilton, and Flaxman," says Dallaway (and to these might now perhaps be added other names of nearly equal promise), "will rescue the present age from being totally indebted to foreigners for perfection in statuary. His present Majesty, at Christ Church, a bust by the first mentioned, has the strength of Bernini." The various productions of this artist which adorn St Paul's Cathedral, Christ Church, and Pembroke Colleges, Oxford, the Abbey Church at Bath, and Bristol Cathedral, give ample testimony to his powers; above all, those great and prominent works among the monuments in Westminster Abbey.

But it was not as an artist only that Mr Bacon was esteemed. He was no less distinguished by the firmness of his mind, and the uprightness of his private character. His principles were deeply founded, and the virtues which he strove to attain were measured by a standard more unbending than the mere dictates of feeling or of a cultivated taste. He was an avowed believer in the truths of the Christian religion; and in him this belief exhibited its corresponding effects, by producing a consistent influence upon his whole character and conduct. In this manner, the strength of his principles, and the reality of his conviction, were daily manifested throughout

* The invention has sometimes been erroneously ascribed to Mons. Hudon, a French Sculptor.

his life; than which, no test of sincerity is more unequivocal, no instruction more useful, and no recommendation more persuasive.

Mr Bacon was remarkable for the simplicity of his manners, and was, in all things, devoid of ostentation. Of the general powers of his mind, and particularly of his acute and just perception in matters

of taste connected with his art, a very favourable opinion will be formed by those who peruse the article *SCULPTURE*, which he contributed to Dr Rees's edition of Chambers's *Dictionary*.

See *Memoir of the late John Bacon, R. A.* By the Reverend Richard Cecil. London, 1811.—(EE.)

B A K I N G

Is the art of making *bread*, by which term is meant *loaf-bread*, which is white, soft, full of cavities, has an agreeable taste, and is easily digested.

History of
the Art.

1. Like most of the arts of primary importance, its origin precedes the period of history, and is involved in the obscurity of the early ages of the world. There is no evidence from Scripture that Abraham was acquainted with the method of making loaf-bread. Cakes and unleavened bread are repeatedly mentioned as made by him, but no notice is taken of loaf-bread. We are certain that it was known in the time of Moses, as in the Jewish law there is a prohibition to make use of it during the celebration of the *passover* (Exodus, chap. xii. verse 15). Egypt, both from the nature of the country and the early period of its civilization, seems very likely to have been the place where this art was first practised. The Chaldeans, however, put in a claim. They were civilized nearly as early as the Egyptians, and they were celebrated among the ancients for the goodness of their bread. The Greeks assure us that they were taught the art of making bread by the God Pan. This lively and superstitious people ascribed almost all the important arts of common life to their gods; or rather, perhaps, their gratitude induced them to deify the authors of these most useful inventions. Bakers were unknown in Rome till the year of the city 580, or about 200 years before the commencement of the Christian era. They settled in that city during the war with Perseus, king of Macedon (Plinii *Hist. Nat.* xviii. 11). It was then that the Romans became acquainted with the refinements of the Greeks, and that their capital became crowded with adventurers of all kinds, with artists and philosophers, from the prolific soil of Achaia. Before this period, the Romans were often distinguished or reproached by the appellation of the *pulse-eating nation*.

Since the introduction of bakers into Rome, the art of making bread has always been practised in the south of Europe. But it made its way into the north very slowly; and even at present in the northern countries of Europe and Asia, loaf-bread is seldom used except by the higher classes of inhabitants. In Sweden, for example, you see rolls frequently in the towns, but never loaves. Göttenburgh is a town containing about 23,000 inhabitants. In the year 1812 it was crowded with merchants from all parts of Europe, being the great connecting link between Britain and the Continent. Towards the end of that year, the captain of an English packet ordered a Göttenburgh baker to bake for him a quantity of bread, amounting to L.1 Sterling in value. The baker was confounded at so great an order, and re-

fused to comply, till the captain gave him security that he would carry off and pay for the loaves; declaring that he could never dispose of so great a quantity of bread in Göttenburgh if it were left upon his hand. In the country part of Sweden, you meet with nothing but rye-cakes, as hard nearly as flint, and which are only baked twice a-year. About thirty years ago, loaf-bread was almost as rare in the country places and villages of Scotland, *barley bannocks* and *oaten cakes* constituting the universal substitutes almost among all ranks. But the case is wonderfully altered at present. At that time no wheat was raised in the fertile valley of Strathearn; and the village of Crieff, the largest village in that valley, with a population of nearly 8000 persons, contained only two bakers, who could scarcely find employment. At present it contains five or six, and each has a brisk trade.

In many parts of England, it is the custom for private families to bake their own bread. This is particularly the case in Kent, and in some parts of Lancashire. In the year 1804 the town of Manchester, with a population of about 90,000 persons, did not contain a single public baker. We do not know whether or not it contains any at present.

2. The only substance adapted for making loaf-bread is the flour of wheat, a grassy plant, distinguished among botanists by the name of *triticum*. This plant is cultivated, perhaps, over a greater extent of the globe than any other, and, like man, it seems to adapt itself to almost every climate. We have seen excellent crops of it raised in north latitude 60°. It is cultivated in the East Indies, considerably within the limits of the torrid zone; and, in the north of Indostan, it constitutes a chief article in the food of the inhabitants. The original *habitat* of this plant is unknown. We know, however, that it improves considerably in its quality as we advance south. The wheat of Essex and Kent brings a much higher price than the wheat raised in East-Lothian and Berwickshire. French wheat is superior to that of England. The Italians have the superiority over the French in their wheaten crops, and perhaps the best wheat of all is raised in Barbary and Egypt. Mr Bruce found wheat growing wild in Abyssinia, and, in his opinion, that kingdom is the native country of the plant. It would seem to be originally an African plant, since it thrives best in Barbary and Egypt; and perhaps the mountains of Abyssinia, though within the torrid zone, may not differ much in point of climate from the more northern plains of Egypt. In India the plant seems to have deteriorated. It is always dwarfish, and the crop, we have been

Different
kinds of
Wheat
Flour.

Baking. told, is less abundant than in more northern climates.

3. The culture of the different varieties of wheat, as practised in this country, and the method of grinding and fitting the flour for the baker, being foreign to the present subject, we cannot, with propriety, touch upon them. It may be sufficient to say, that originally, in England, the baker was his own manufacturer. He purchased his own wheat, and got it ground as he wanted it. At that period, the miller separated the wheat into three portions; namely, flour, pollard, and bran. The bran was the outside of the grain. It was not used as food at all, or only given to horses. The *pollard* was the portion of the grain next the husk; it was coarser and darker coloured than the *flour*, which constituted the interior or central portion of the grain. This flour, at an average, amounted to three-fourths of the wheat ground. But, by insensible degrees, the manufacture of bread became separated into two distinct employments, that of the mealman, who ground the wheat and sold the flour, and that of the baker, who converted it into bread. The mealman made different kinds of flour, some extremely fine and white, while others were very coarse and unpalatable. This white flour, when made into bread, was so pleasing to the eye and the taste, that it gradually got into general use, and the people refused to purchase the bread made of the whole of the flour. At present, in the mills in the neighbourhood of London, wheat is divided into no fewer than seven distinct kinds of flour. The following are the average proportions of these obtained from a quarter of wheat:

Fine flour	-	5 bushels, 3 pecks.
Seconds	-	0 2
Fine middlings	0	1
Coarse middlings	0	0.5
Bran	-	3 0
Twentypenny	-	3 0
Pollard	-	2 0
		<hr/>
		14 2.5

Thus we see that wheat almost doubles in bulk by being ground into flour.

During the bolting of the wheat, there is a fine white gritty substance, called *sharps*, obtained. It constitutes the centre and finest part of the grain of wheat. This is partly sold to the biscuit-makers, and is employed in baking the finest kind of sea-biscuit. It is partly ground again, and constitutes the finest and most valuable kind of flour.

4. The bakers in Great Britain, at present, are restricted by act of Parliament to bake only three kinds of bread, namely, *wheaten*, *standard wheaten*, and *household*. The first must be marked with a W, the second with S W, and the third with H; and the baker who neglects to mark them in this manner is liable to a penalty. The wheaten loaf is made of the finest flour, the standard wheaten of the whole flour mixed together, and the household of the coarser flour. The loaves baked are usually peck loaves, half peck, and quarter loaves; the weights of which, provided they be weighed within forty-

eight hours of the time of baking, must be as follows:

	lbs.	oz.	dr.	Avoirdupois.
Peck loaf	17	6	0	
Half peck	8	11	0	
Quartern	4	5	8	

Before these loaves are put into the oven, they weigh,

	lbs.	oz.
Peck loaf	19	12
Half peck	9	14
Quartern	4	15

From this it appears, that the average loss of the quartern loaf in weight by baking is $9\frac{1}{2}$ ounce, or not quite so much as one-seventh of the whole. From the experiments of Tillet, and the other French commissioners who were appointed to examine the subject in 1783 (in consequence of an opinion prevailing in Paris that the bakers did not give the full weight, while these tradesmen declared that they put the proper quantity of flour in the loaves), it appears that the French loaf loses a considerably greater weight in the oven. A loaf which, when put into the oven, weighed 4.625 lbs. when taken out of the oven, weighed at an average only 3.813 lbs. or 0.812 lb. less than at first. This amounts to somewhat more than one-sixth, or very nearly to $\frac{1}{6}$ ths of the whole. This greater loss is chiefly owing to the difference between the shape of the English and French loaf. The English has nearly a cubic form, while the French loaf is very long and slender. For it is obvious, that the loaf which presents the greatest surface must lose most weight in the oven.

The French commissioners, however, found that this loss of weight was by no means uniform, even with respect to those loaves which were in the oven at the same time, of the same shape, in the same place, and which were put in and taken out at the same instant. The greatest difference in these circumstances amounted to 0.2889 or 7.5 parts in the hundred, which is about $\frac{1}{13}$ th part of the whole. According to this rate, we may suppose that an English quartern loaf, when taken out of the oven, may vary in weight $\frac{1}{13}$ th part, which amounts to rather more than $4\frac{1}{2}$ ounces. So that the law which subjects the baker to a penalty if his bread weighs one ounce less than it ought to do, seems too severe, and must have a tendency to injure the goodness of the bread, by making the baker more solicitous about the weight than the quality of his loaf. To this we ascribe in part the badness of the London bread in general, compared with the bread in other places, particularly in Edinburgh, where it is remarkably good. But there are other causes for this deterioration of the London bread, which we believe to be of recent date. These we shall notice hereafter.

5. A sack of flour weighing 280 lbs. and containing five bushels, is supposed capable of being baked into 80 loaves in the acts of Parliament regulating the assize upon bread. According to this estimate, $\frac{1}{4}$ th of the loaf consists of water and salt, the remaining $\frac{3}{4}$ ths of flour. But the fact is, that the number of quartern loaves that can be made from a sack of

Different kinds of Bread.

Baking. flour, depends entirely on the goodness of that article. Good flour requires more water than bad flour, and old flour than new flour. Sometimes 82, 83, or even 86 loaves may be made out of a sack, sometimes scarcely 80.

Process of Baking. 6. Let us now proceed to give a short description of the mode of baking as practised in Great Britain.

The bakehouse ought to be a large room. On one side should be erected a dresser with suitable shelves above it; on another side a kneading-trough, about seven feet long, three feet high, two feet and a half broad at top, and nineteen inches at bottom, with a sluice-board to pen the dough up at one end, and a lid to shut down like that of a box. On a third side should be a copper, capable of holding three or four pailful of water, with a fire-place to warm the liquid. The oven of course occupies the fourth side. It is a square apartment about three or four feet high, with an arched circular roof, and a brick or stone floor, and furnished with a door which may be shut close. It is the general custom to heat the oven with wood, either faggots or brushwood; but it would be much more economical and cleanly to employ pit-coal for that purpose. The requisite fire-place should be erected at one side of the oven, and the heat may be easily communicated by making the flue wind round the oven. This fire may also be employed to heat the copper and the water in it, which would save an additional fire, or spare the baker the disagreeable necessity of heating the copper in the oven itself, which is pretty generally practised in London. We are persuaded that an oven, constructed upon this principle, would save the baker a considerable annual expence, which, for many years past, has been continually increasing. Indeed, it is obvious that the price of wood must keep pace with the augmentation of the population and wealth of the country.

The temperature to which the oven must be raised to fit it for baking bread is 450°. (*Encyclop. Method. Arts et Metiers*, I. 275.) The bakers do not employ a thermometer; but they reckon the oven sufficiently heated, when flour thrown on the floor of it becomes black very soon without taking fire.

Let us suppose that a baker is going to convert a sack of flour into loaves. He pours the flour into the kneading-trough, and then sifts it through a fine wire sieve, which makes it lie very light, and serves to separate any impurities with which the flour may be mixed. An ounce of alum* is then dissolved over the fire in a tin pot, and the solution poured into a large tub, called by bakers *the seasoning-tub*. Four pounds and a half of salt are likewise put into the tub, and a pailful of hot-water. When this mixture has cooled down to the temperature of 84°, three English pints of yeast are added; the whole is well mixed together, strained through the seasoning sieve, emptied into a hole in the flour, and mixed up

Baking. with the requisite portion of it to the consistence of a thick batter. Some dry flour is then sprinkled over the top, and it is covered up with cloths. This operation is called in London *setting quarter-sponge*.

In this situation it is left about three hours. It gradually swells and breaks through the dry flour scattered on its surface. An additional pailful of warm water is now added, and the dough is made up into a paste as before; the whole is then covered up. This is called *setting half-sponge*. In this situation it is left about five hours.

Three pailfuls of warm water are now added; the whole is intimately blended and kneaded upwards of an hour. The dough is then cut in pieces with a knife, thrown over the sluice-board, and penned to one side of the trough. Some dry flour is sprinkled over it, and it is left in this state for four hours. It is then kneaded again for half-an-hour. The dough is now cut into pieces, and weighed in order to furnish the requisite quantity for each loaf; four pounds fifteen ounces being allowed for every quarter loaf. The method of moulding the dough into a loaf can scarcely be described, and can only be learned by ocular inspection. The loaves are left in the oven about two hours and a half. When taken out, they are carefully covered up, to prevent as much as possible the loss of weight.

The above description applies only to the mode of baking as practised in London. No doubt, slight differences exist in different countries. The French loaf, which is baked in a pan, requires obviously a different process from the English loaf, and it is kept a longer time in the oven.

Alum is not added by all bakers. The writer of this article has been assured by several bakers of respectability, both in Edinburgh and Glasgow, on whose testimony he relies, and who made excellent bread, that they never employed any alum. The reason for adding it, given by the London bakers, is, that it renders the bread whiter, and enables them to separate readily the loaves from each other. This addition has been alleged by medical men, and is considered by the community at large, as injurious to the health by occasioning constipation. But if we consider the small quantity of this salt added by the baker, not quite 5½ grains to a quarter loaf, we will not readily admit these allegations. Suppose an individual to eat the seventh part of a quarter loaf a-day, he would only swallow eight-tenths of a grain of alum, or, in reality, not quite so much as half a grain; for one-half of this salt consists of water. It seems absurd to suppose that half a grain of alum, swallowed at different times during the course of a day, should occasion constipation.

7. The addition of the yeast of beer to make the dough swell is an improvement of the original practice. *Leaven* was used by the ancients for this purpose. Hence we read in the Old Testament of *unleavened bread*, as distinguished from *loaf-bread*.

* In London, where the goodness of bread is estimated entirely by its whiteness, it is usual with those bakers who employ flour of an inferior quality, to add as much alum as common salt to the dough. Or, in other words, the quantity of salt added is diminished one-half, and the deficiency supplied by an equal weight of alum. This improves the look of the bread very much, rendering it much whiter and firmer.

Baking.

The method of baking by means of leaven was this: A quantity of flour is made up into dough with water; this dough being set in a warm place, is left for about thirty-six hours. During that period it swells considerably, and becomes of a thinner consistency. In short, it undergoes a species of fermentation. It has now acquired a peculiar smell, and a disagreeable sour taste, and is the substance known by the name of *leaven*. If this substance be mixed with a quantity of fresh dough, it occasions the whole to undergo a speedy fermentation, and to swell precisely in the same manner as dough mixed with yeast. Bread skilfully baked in this manner is not inferior to yeast bread; but when unskilfully managed, it has a sour taste, and contains a quantity of acetic acid. According to the experiments of Mr Edlin, a pound of flour, when converted into leaven, contains as much acetic acid as requires 40 grains of carbonate of potash to neutralize it. If by carbonate he means (as is probable) *bicarbonate* of potash, 40 grains of it contain 21 grains of potash, which requires for saturation $22\frac{1}{2}$ grains of acetic acid.

Pliny informs us that yeast in his time was employed in Spain and Gaul as a *ferment* of bread. *Galliæ et Hispaniæ frumento in potum resoluto, quibus diximus generibus, spuma ita concreta pro frumento utuntur. Qua de causa levior illis quam cæteris panis est.* (*Natur. Hist.* lib. xviii. c. 7.) From this passage we see that the Romans employed leaven to raise their bread, but that they were sensible of the superiority of yeast. Leaven, however, made its way both into France and Spain, and was universally employed in the manufacture of bread till towards the end of the seventeenth century, when the bakers of Paris began to import yeast from Flanders, and to employ it pretty generally as a substitute for leaven. We have here a striking instance of the blindness and obstinacy of the learned and the powerful, and the readiness with which they are disposed to arm themselves against all alterations and improvements. The bread by this substitution was manifestly improved both in appearance and in flavour. This variation excited attention; the cause was discovered; the faculty of medicine in Paris declared it prejudicial to the health; the French government interfered, and the bakers were prohibited, under a severe penalty, from employing yeast in the manufacture of bread. But it is in vain for governments, colleges, and universities, to oppose themselves to those improvements which take place in the arts and manufactures essential to civilized society. The ingenuity and perseverance of self-interest is proof against prohibitions, and contrives to elude the vigilance of the most active government. The laws of Queen Elizabeth, however tyrannical and absurd, did not prevent the introduction of indigo as a dye-stuff into England. Neither did the authority of Louis the Fourteenth, nor the decision of the physicians, deter the Parisian bakers from persisting in their improved mode of making bread. The yeast in Flanders was put into sacks, the moisture was allowed to drop out, and in this comparatively dry state it was carried to the capital of France.

The superiority of yeast bread became gradually visible to all, the decisions of the medical faculty

were forgotten, and the prohibition laws were allowed tacitly to sink into oblivion. The new mode of baking by degrees extended itself to other countries, and is now, we believe, practised everywhere. In warm climates, where the yeast of beer cannot be had, other substitutes are employed, which answer the same purpose. In the East Indies, bread is raised by means of the liquor called *toddy*, which flows out of the cocoa-nut tree when its branches are cut, and which ferments so rapidly, that in two or three hours it becomes an intoxicating liquor. In the West Indies *dunder* is employed for the same purpose. This is the liquid which remains in the still after the rum is distilled off, and is therefore analogous to what our distillers call *spent wash*. It no doubt consists of a solution of unaltered sugar, prevented from fermenting by the alcohol which the liquid contained before distillation, and mixed doubtless with a quantity of yeast. In that warm climate it undergoes a very speedy fermentation, and on that account answers all the purposes of yeast in the baking of bread. In this country it is no uncommon thing to convert the spent wash into small beer, which the workmen drink with avidity. But it only undergoes this change when fermented in the usual way with yeast.

8. The appearance of wheat flour is too familiar to every person to require any description here. The ancients knew that it consisted chiefly of a substance called *starch*; which, as Pliny informs us, was first separated from wheat by the inhabitants of the Island of Chio, and in his time the starch of Chio was considered the best and lightest, because it was made from wheat which was not ground. (*Plinii Natur. Hist.* 18. 7.) This is the mode still followed by the manufacturers of starch, and is no doubt the reason why the other constituents of wheat were so long in being discovered. About the year 1728 Beccaria, an Italian philosopher, discovered another constituent of wheat, to which the name of *gluten* has been given. His method of obtaining it was this: He took a quantity of flour, and formed it into dough with water; this dough he kneaded continually between his fingers, while a small stream of water dropt upon it. He continued the kneading as long as the water ran off milky. By this process, the whole of the starch was washed away, and there remained in his hand a grey-coloured, elastic, and very adhesive substance, which was the gluten. (*Collect. Academ. partie Etrang.* 10. 1.) No other grain, besides wheat, contains gluten in any considerable quantity. Traces of it may be discovered in barley. But the gluten of barley cannot be separated by washing. It is obtained by solution in water. For gluten is soluble in a small proportion in cold water. But when that liquid is heated to 120° or 130° the gluten coagulates, and falls down in grey-coloured flocks. By this method gluten may likewise be discovered in the leaves of many trees.

The water employed to wash out the starch soon deposits that substance in the form of a white powder. If this water be now filtered, evaporated to a small quantity, filtered again to separate the coagulated gluten, clarified with white of egg, and then evaporated to the consistence of a syrup, it deposits,

Baking.

Baking. according to Mr Edlin, crystals of sugar in four-sided prisms, with dihedral summits. (Edlin on *Bread Making*, page 49.) If this experiment be correct, wheat contains a portion of common sugar. But we have great doubts respecting it. We scarcely believe it possible to obtain in regular crystals the very small quantity of sugar that must be contained in a pound of wheat by the process described by Mr Edlin, for he merely set the syrup aside to crystallize in a cool place. Common sugar thus treated would concrete into a hard mass, but would not crystallize. We believe that wheat flour contains a portion of saccharine matter, but it is a species different from common sugar. We have never, indeed, made any experiments on the sugar of wheat, but we have made a great many on the saccharine matter of barley, which we found similar in its properties to the sugar into which starch is converted by being long boiled in very dilute sulphuric acid. There is every reason to believe that the sugar in wheat is similar to that in barley. Now, the sugar in barley crystallizes in spheres similar to candied honey.

9. Starch, the first, the most important, and by far the most abundant constituent of wheat flour, is a white, crisp, crystalline-like substance, insoluble in cold water, but forming with hot water a thick paste, which has the property of gluing bodies together. If it be roasted on the fire till it assumes a brown colour, it becomes soluble in water, and acquires the properties of gum. If it be boiled for forty-eight hours in water, holding one-hundredth part of its weight of sulphuric acid in solution, it is dissolved and converted into a species of sugar. This sugar is heavier than the starch from which it was formed; the sulphuric acid remains unaltered; and no gaseous body is either absorbed or emitted. Hence it has been concluded, that this sugar is merely a combination of starch and water; and that the acid acts only by promoting the solution of the starch, without which it is incapable of uniting with water. Starch is one of the most nourishing articles of food, and is undoubtedly the portion of the wheat flour that renders bread so nutritive.

10. The gluten, the second constituent of wheat flour, is but small in quantity when compared with the starch. It is a grey substance, exceedingly elastic and adhesive. It is not sensibly soluble in water after it has been collected into an adhesive mass. Nor does it dissolve in alcohol or ether. When dried, it becomes brown and semitransparent, and when thrown on hot coals, emits a smell similar to that of burning horn. If it be put into a vessel, moist, and set in a damp place, it undergoes a species of fermentation. Bubbles of gas separate from it. After some days it becomes of a much thinner consistence, and then may be employed to agglutinate substances together. In about ten days or a fortnight, it acquires exactly the smell and taste of cheese, which it resembles in every thing but the colour, which is too dark. This *caseous* fermentation, if the expression may be permitted, distinguishes gluten from all other vegetable bodies with which we are acquainted. It is to the gluten that wheat flour owes the property of being converted into loaf-bread. All other grains are unfit for that purpose, but they become fit as soon

as we add to them a sufficient quantity of gluten, or mix them with wheat flour. In this way barley, potatoes, and even turnips, may be made into very good bread.

11. The sugar is by far the smallest, in proportion, of all the constituents of wheat flour. If it be starch sugar, as we believe it to be, it possesses the following properties: It does not crystallize in prisms like common sugar, but assumes the form of spheres like honey. It is not so hard as common sugar, neither is it so soluble in water. Its sweetening power, according to Kirchhoff, is to that of common sugar as 1 to 2½. But the most distinguishing property is that, when dissolved in water, it ferments of itself, without the addition of any yeast; whereas common sugar does not undergo that process unless yeast be mixed with its aqueous solution. Hence the reason why the dough of wheat flour ferments, and is converted into leaven. This fermentation does not take place if the saccharine matter be washed out of it by water, as Mr Edlin ascertained by direct experiment. The fermentation of wheat flour is at first confined to the saccharine matter. It first undergoes the vinous fermentation; here the process, if possible, ought to be stopped. But as this is usually not possible, the acetous fermentation commences, and vinegar is formed. Probably at last the starch itself is acted on, and occasions the bad taste of ill baked leavened bread, though this is doubtful.

12. As to the proportions of these three constituents, they differ so much in different kinds of wheat flour, that nothing precise on the subject can be determined. The greater the proportion of gluten, the better in all cases is the flour. When the wheat has not fully ripened, or when it has been exposed to rain while lying on the field, the gluten cannot easily be separated from the starch by the process above described; nor does it form an elastic, adhesive mass; but a friable substance, distantly resembling the fibrous matter of potatoes. Hence the goodness of the flour may be determined by the state of the gluten. The writer of this article has repeatedly applied this test to London flour; but he has been always unlucky enough to find it decidedly bad. From the flour furnished by two or three different bakers in different parts of the town, he either was unable to obtain any gluten, or it wanted the adhesiveness which characterizes the gluten of good wheat. No doubt, there must be abundance of excellent flour in London; but we believe (and our opinion is founded on the bread, which, in general, is greatly inferior in goodness to the Edinburgh bread) that a very considerable proportion of the flour used is bad. The inhabitants of London pride themselves on the goodness of their bread; but never was any set of men more mistaken. The London bread is, indeed, whiter; but, in other respects, worse than any we have met with in Great Britain, except the bread baked in Berwick-upon-Tweed, which is very bad, owing entirely to the unskilfulness of the bakers.

To furnish an idea of the proportions of the constituents of flour in good wheat, we shall give the result of an analysis of Mr Edlin's. He separated a pound avoirdupois of wheat into the following ingredients:

Baking.

	oz.	dr.
Bran - - -	3	0
Starch - - -	10	0
Gluten - - -	0	6
Sugar - - -	0	2
Loss - - -	2	0
Total	16	0

In this case, it appears that the gluten amounted to $\frac{1}{4}$ of the whole flour, the sugar was $\frac{1}{4}$ th part, the bran $\frac{1}{4}$ th, and the starch almost $\frac{1}{4}$ ds of the whole flour.

Modes of preparing Yeast.

13. The yeast which is employed to ferment or raise the dough is obtained in London from the brewers of ale. In Edinburgh, the greatest part of the yeast used by the bakers is either prepared by these tradesmen themselves, or procured from those who manufacture yeast on purpose to supply the bakers. Various methods and various ingredients are used for this purpose; but the following method is, we believe, as good as any:

Add ten pounds of flour to two gallons of boiling water: stir it very well into a paste. Let this mixture stand for seven hours, and then add about a quart of yeast. In about six or eight hours, this mixture, if kept in a warm place, will have fermented, and produced as much yeast as will bake an hundred and twenty quartern loaves.

Yeast made in this way answers the purposes of the baker much better than brewers' yeast; because it is clearer, and free from the hop mixture, which sometimes injures the yeast of the brewer. Some years ago, the bakers of London, sensible of the superiority of this artificial yeast, invited a company of manufacturers from Glasgow to establish a manufactory of it in London, and promised to use no other. About L. 5000 accordingly were laid out on buildings and materials, and the manufactory was begun on a considerable scale. The ale brewers, finding their yeast, for which they had drawn a good price, lie heavy on their hands, invited all the journeymen bakers to their cellars, gave them their full of ale, and promised to regale them in that manner every day, provided they would force their masters to take all their yeast from the ale brewers. The journeymen accordingly declared in a body, that they would work no more for their masters unless they gave up taking any more yeast from the new manufactory. The masters were obliged to comply; the new manufactory was stopped, and the inhabitants of London were obliged to continue to eat worse bread; because it was the interest of the ale brewers to sell their yeast. Such is the influence of journeymen bakers in the metropolis of England!

What the substance in yeast is which induces fermentation has not yet been determined. Beer yeast may be dried, and kept in that state for a considerable length of time, and if moistened again with water, it becomes capable of acting as a ferment. If it be washed in alcohol, its fermenting power is destroyed. If it be kept in a moist place, it undergoes a change very similar to the caseous fermentation of gluten. But yeast and gluten are distinct substances; for gluten is incapable of producing the vinous fermentation. Sugar of starch ferments of itself when diluted with

water, and the juice of grapes also ferments of its own accord, because it contains a quantity of sugar similar to the sugar of starch.

Baking.

But as far as baking is concerned, the knowledge of the peculiar substance which occasions fermentation is not material. The only useful purpose which fermentation in dough serves, is to generate a quantity of carbonic acid gas. If the dough be impregnated with this gas by any other method, fermentation is not necessary. Mr Henry of Manchester found, that if flour be kneaded into dough with water saturated with carbonic acid gas, the dough rises as well, and the bread is as light and well tasted as when it is baked with yeast. Hence, those bakers who live near Seltzer water, or any water impregnated with carbonic acid gas, may substitute that liquid for yeast, without injuring the quality of their bread. The quantity of salt contained in a quartern loaf, may be reckoned about an ounce avoirdupois, or 437 grains. If, instead of the ounce of salt, you dissolve in water 2 oz. 5 dr. 45 gr. of the common crystallized carbonate of soda, and mix the solution well with your dough; if you now add 7 oz. dr. 22 gr. of muriatic acid, of the specific gravity of 1.121, and knead it as rapidly as possible with the dough, it will rise immediately, fully as much, if not more, than dough mixed with yeast, and when baked, will constitute a very light and excellent bread.

14. These examples are sufficient to explain what Panary is called the *panary* fermentation. There is, in fact, no such thing as a fermentation peculiar to bread. But wheat flour contains a portion of saccharine matter, which readily undergoes the vinous fermentation. During this fermentation, carbonic acid gas is evolved in every part of the dough. This gas is prevented from escaping by the gluten, which forms every where through the dough an adhesive web, through which gaseous substances cannot make their way. Hence, the dough swells in every direction, the particles of starch are separated from each other, and by the heat of the oven, they are arrested in that position. So that the loaf, when cut, appears full of round and oblong cavities, each of which in the dough had been filled with a globule of carbonic acid gas. It is to the presence of these cavities that the bread owes its lightness, its agreeable taste, and its easy digestion. Even its colour is owing, in a great measure, to the same cause. For when loaves of wheat flour are baked without the addition of yeast, or the presence of carbonic acid, they constitute one solid, dark-coloured, disagreeable tasted mass, which has been found not only nauseous to the palate, but likewise of difficult digestion. These disagreeable qualities are, in a great measure, obviated by converting the dough into thin cakes, and baking them rapidly on a hot iron plate over the fire. Accordingly, this is the method followed, when wheat flour is converted into bread without fermentation.

Thus then the theory of bread making is completely developed. Nothing can be simpler or more ingenious than the process followed by the baker. Nor ought the wonderful composition of wheat flour, which adapts it so well for the manufacture of bread, to be passed over in silence. Without the presence of the saccharine matter, the fermentation could not

Nutritive Qualities of Bread.

Baking. be produced in it, carbonic acid gas would not be evolved, and the bread would be hard, heavy, black, and difficultly digestible. Without the presence of the gluten, the carbonic acid would make its escape as soon as formed, and the advantages of the fermentation would be lost. And, finally, without the presence of the starch in such a notable proportion, the bread would neither be a palatable nor a nourishing article of food. It has been supposed; indeed, that the gluten is the substance which renders bread so nourishing. But we conceive this to be a mistake. In the first place, its quantity, when compared with that of the starch, is trifling. And, in the second place, we know from other circumstances, that starch is peculiarly fitted for being the food of animals. Nearly one-half of the human race live almost wholly on rice, a grain which consists almost entirely of starch; and the small quantity of that grain which constitutes the daily food of an inhabitant of Indostan, and which supports his life, is truly astonishing.

Potatoe Bread. 15. As no other grain except wheat flour contains these three constituents, in the requisite proportions, it would be in vain to attempt to convert them into bread, by the same process as is followed by the baker in making wheaten bread. Potatoes, for example, contain no sensible quantity of saccharine matter. It would be in vain, therefore, to expect them to ferment, like wheat dough, when mixed with yeast. But we have little doubt, that mashed potatoes might be made into very good bread, if they were kneaded with water impregnated with carbonic acid gas, or still better, if, instead of common salt, the constituents of that substance were added in the proper proportions, as they have been already given in this article. Potatoes contain a very great proportion of water, and when boiled in water, they communicate a brown colour, and give the liquid a disagreeable taste and smell.

It is proper that this substance, which some have considered as of a poisonous nature, should be previously removed. Einhof has given us the following substances as the constituents which he found in potatoes:

Water	-	-	72.6
Starch	-	-	15.0
Fibrous matter	-	-	7.0
Albumen	-	-	1.4
Mucilage	-	-	4.0
			100.0

Dr Pearson's analysis is somewhat similar; only he obtained a greater proportion of water. Einhof found both tartaric and phosphoric acid in potatoes. The fibrous matter in potatoes seems to be a peculiar modification of starch. It supplies the place of the gluten in wheat flour, and gives to the paste of potatoes considerable stiffness and adhesiveness. It is upon these properties that we found our opinion, that if the paste of potatoes were properly impregnated with carbonic acid gas, it would make a good-looking and well tasted loaf. There is, however, the less occasion for this attempt, as potatoes, when properly boiled, constitute an agreeable substitute for bread, without any farther preparation. When

Baking. made into bread, they are always mixed with wheat flour. A mixture of two parts flour, and one potatoes, makes an agreeable bread, which cannot be distinguished from wheaten bread. The starch of potatoes is remarkably beautiful, and goes farther than wheat starch. We have been assured, that what is sold in the shops under the name of Indian arrow root, is nothing else than potatoe starch mixed with a little gum tragacanth. It is well known what an agreeable food this preparation is capable of furnishing.

Rye is very much used as an article of food in northern countries. In Sweden it constitutes almost the only bread of the common people not baked in loaves; but made up into cakes, which are usually as hard as wood. When baked into loaves, it has a brown colour and a sweetish taste, which gives it a considerable resemblance to gingerbread. Rye, according to the analysis of Einhof, is composed of the following constituents:

Albumen	-	-	3.27
Moist gluten	-	-	9.48
Mucilage	-	-	11.09
Starch	-	-	61.09
Saccharine matter	-	-	3.27
Husk	-	-	6.38
Moisture	-	-	5.42
			100.00

The saccharine matter present in this grain is probably sufficient to cause it to undergo fermentation. But the proportion of gluten is very small; probably not amounting to 3 per cent. Accordingly, when rye flour is washed in water, the whole of the gluten is dissolved in that liquid. Hence it is obvious, that, in order to make good rye bread, it ought to be mixed with a quantity of wheat flour. This kind of bread is very much used in the counties of Northumberland and Durham, and we have no doubt that it is both palatable and nourishing. Certainly it is very far superior to the rye cakes, used by the peasants in Sweden.

We have been told that rice flour may be made into loaf-bread. But we have never had an opportunity of seeing these loaves, and do not know how far they resemble those of wheat flour. Rice has never been subjected to chemical analysis. We do not know, therefore, what its constituents are; though there is every reason, from its properties, to consider it as almost entirely composed of starch.

16. Having now given a description of the method of baking bread, and explained the nature of the process, we might here conclude this article. But it may be of some utility, if we give a short statement of the principal laws which have been enacted in Great Britain respecting bread, and if we endeavour to lay before the public the present state of the bread trade in London, and explain the abuses and frauds that are practised by those concerned in it in that capital. We despair of seeing these abuses rectified; but it is a great point at least to make them known.

In the period of English history, between the Norman conquest and the reign of Edward the First, the price of wheat fluctuated enormously. Thus, in the

Assize of Bread, and State of the Bread trade in London.

Baking. 43d year of Henry the Third, it was sold for 20s., or 60s. of our money, a quarter. Multitudes of poor people were forced to live upon the bark of trees, and upon horse-flesh, and above twenty thousand died in London of famine. In the same reign, as appears from the statutes, the price of wheat was as low as 1s. a quarter. These prodigious fluctuations show the little communication at that time existing between the different countries of Europe. Farming must have been in a very low state in England. When wheat was very cheap, the farmer could not dispose of his crop, which lay rotting on his hands. When it was dear, there was such a scarcity, that he could hardly procure seed for sowing his fields, or was unable to afford money to purchase it.

It was conceived, that these evils would be, in a great measure, remedied by fixing the price of bread, which was accordingly done by a proclamation of King John. This absurd innovation being found ineffectual, it was repealed by the *statute of assize*, enacted in the 51st year of Henry the Third, *anno Domini* 1267. By this law, the price of bread was regulated by the price of wheat, and the baker was allowed 7½d. for baking a quarter of wheat, and furnishing salt and the other ingredients which are added to bread; besides the profit which accrued from the additional loaves made from a quarter of wheat beyond what the statute allows. This money allowance was gradually augmented to the baker in different reigns, according to the following statement:

			s.	d.
Edward I.	-	to	-	1 1
Henry VII.	-	-	-	2 7
Elizabeth	-	-	-	6 10
Elizabeth	-	-	-	6 0
Anne	-	-	-	12 0
George II.	-	-	-	15 6
George III.	-	-	-	14 0

This last regulation took place in the year 1798. By this act, the magistrates were enjoined to set the assize from a sack of flour, instead of a quarter of wheat, and to allow the baker 11s. and 8d. for his expences. The new duty on salt, during the French revolutionary war, raised this sum to 12s. at which it continued. By the act of Parliament, the baker was supposed to make 80 quarter loaves from the sack of flour; whatever greater number the sack produced was so much more profit to the baker.

Very particular laws were enacted, obliging the corn-factors to give in the quantities and prices of the flour sold, and the bakers the quantities and prices at which they bought it. Penalties were enacted to prevent false returns, to prevent adulterations and improper combinations between the bakers, or the corn-factors and bakers. The weight of the loaf was determined, and all loaves deficient in weight one ounce, or not marked with the letters W, S W, H, according to the quality of the bread, may be seized; and the baker, besides the loss of his bread, is subjected to a penalty. These laws are so numerous, and so minute, that it would be tedious to copy them. Nothing more would be learned from them but the

Baking. amount of the penalty for each offence, varying from L. 50 to 1s., according to the supposed enormity of the transgression. It is the business of the magistrates in towns, and of justices of the peace in the country, to regulate the assize, and the price of bread is determined by the price of wheat, according to a table given in one of the acts. When that price varies 6s. the quarter, then the price of the loaf is varied one assize, or a halfpenny the quarter loaf. Magistrates likewise may alter the price of the loaf half an assize, or a farthing in the quarter loaf.

Whoever considers the indecent way in which oaths are administered in English courts (for it is upon the oaths of the bakers and corn-factors that the acts depend for the accuracy of the returns), and the little regard paid to them by merchants and manufacturers, partly in consequence of this indecency, partly in consequence of their multiplicity, and partly on account of the many absurd impediments that the Legislature has thrown in the way of merchants and manufacturers—whoever considers these things, will be at no loss to conclude, that all these checks, and penalties, and oaths, have entirely failed in producing the intended effects. In London, where the number of bakers is great, and the competition in consequence ought to ensure the best bread at the lowest possible price, the bread laws, by making the prices of all bakers the same, have destroyed this competition, have formed the bakers into a regular company, having occasional meetings to consult their peculiar interests, and have raised in them a spirit of honour, which makes them to consider it as unhand-some to undersell their neighbours. The price of flour is easily regulated between the bakers and the corn-factors, the consequence of which regulation is, that the quarter loaf is always 2d. dearer than in any other part of Great Britain. The reason assigned is, that the finest flour only is employed in London, and that the London bread is better than any other. The writer of this article is well aware of the contrary. The London bread is, in his opinion, nearly the worst bread in Great Britain; and the flour is greatly inferior to what is used by the bakers in Edinburgh. He has frequently examined flour purchased from bakers in both cities, and the Edinburgh flour, except in bad years, when the crop had been injured, was uniformly superior in quality to the London flour.

The magistrates of London have at last become sensible of the truth of these facts; and that the Government, by their officious interference, and their minute enactments, have injured instead of improved the quality of the bread. They have, in consequence, applied to Parliament, and by their influence, the assize on bread, as far as it affects London and its environs, has been taken off. But the good effects expected have not yet resulted from this judicious measure. The spirit of monopoly has been sunk so deep into the minds of the bakers by the assize laws, that some time must elapse before it be eradicated. It is said that they have a weekly meeting, and settle the assize privately in the same manner as it was before publicly done by the Lord Mayor and Aldermen of London. But this *esprit de corps* cannot continue very long. Where there are 1600 ba-

Baking. kers, as in London and Westminster, it is not consistent with the nature of things to suppose that they can long continue united, so as to act only together, and by concert. Self-interest will induce first one individual, and then another, to consult his own private advantage, and to endeavour to secure an increase of business by underselling his neighbours. The bond will thus be broken asunder, and every one will be obliged to serve the community at the lowest possible rate.

It is a pity that the Legislature would not see that the same liberty which has been given to the baker, ought to be extended to the corn trade in general. The depreciation of money, which was the consequence of the unnatural state into which Europe was brought by the French revolution, our almost total seclusion from the Continent, and a series of bad crops for several years, raised the price of corn in this country to an enormous height. The landlords took advantage of this increase to raise the rents, while Government loaded the farmer with heavy taxes. But in a state of peace, and supposing the seasons to be tolerably favourable, the prices cannot be kept up. The landed proprietors, indeed, conceived, that corn could be continued in this country at its unnatural height, simply by prohibiting the importation of foreign corn. It was with this view that the corn-bill was brought into Parliament, and carried last year (1815) by a great majority, notwithstanding the almost universal expression of the inhabitants of Great Britain against the measure. These legislators did not consider that the average deficiency of corn in Great Britain does not amount to a week's consumption: that though they may prevent corn from being imported into Great Britain, they cannot prevent such of the inhabitants as choose it from going to those places where corn is cheap. The corn-bill will not have the effect of keeping up the price of corn; but it will act as an encourager of emigration. Suppose the population of Great Britain to be 12,000,000, the emigration of 100,000 inhabitants would probably be sufficient to prevent the necessity of importing corn. Perhaps a smaller number would be sufficient, as those who will be obliged to emigrate are chiefly families with small fortunes, who may be supposed to consume more wheaten bread than the very lowest of the people. The hardships of the farmer cannot be alleviated in any other manner than by lowering his rent, and easing him of his oppressive taxes.

17. About sixty years ago, the dealers in corn in London carried on their business at Bear Quay; but, this situation being very inconvenient, the Corn Exchange in Mark Lane was erected by a company of proprietors for the accommodation of the factors and dealers. Seventy-two stands were allotted on which the samples of corn are exposed to sale. Sixty-four of these stands are let out on lease to factors or dealers, and the remaining eight are appropriated to the use of the Kentish hoymen. "Although the Corn Exchange is considered as open to all who come to buy and sell, yet no person can carry on the business of a corn-factor, to any considerable extent, unless he is in possession of one of these stands. Here the factors are at liberty, either to expose all their samples at the same time, or as few

of them as they think fit: so that a buyer has no means whatever of judging, from the appearance of the samples exposed on the stands, during any period of the market, what the supply is, or what quantities of corn are imported, coastwise, or from abroad." (*Report of the Committee of the House of Commons respecting Corn.*)

Here the millers, mealmen, and corn-chandlers, transact their business with the corn-factor, and not with the seller. These men purchase the wheat, carry it down to Essex and other counties, convert it into flour, and bring it back to London to supply the bakers. The profits of the baker are but small, supposing him to carry on his trade without any fraud. Let us suppose him to bake 12 sacks a-week, which, from the evidence of the bakers examined before the Committee of the House of Commons, seems to be a fair average. They are allowed 12s. for each sack, which amounts in the week to L.7. Let us suppose farther, that every sack yields 82 loaves instead of 80, so that they have a profit of two loaves on each sack. This, when the quarter loaf is at 10d., will amount to L.1 more. Let us suppose farther, that the puddings, pyes, and meat, which they bake, will defray the expense of their fuel. By this statement, their weekly income will be L.8. Out of this they have to pay for salt and yeast, and likewise their journeymen's wages. Now, L.4 seems as little as can well be allowed for these purposes. According to this statement, L.208 a-year seems to be the amount of an ordinary baker's income in London, supposing him not to practise any fraud.

The consequence of this small profit is, that men of capital seldom embark in the trade. The bakers in London are mostly poor men, who begin the world without any capital; and in consequence of the great competition, are never able to deal so extensively as to acquire one. It is scarcely necessary to observe what must be the consequence of this. They are at the mercy of the mealmen, who supply them with flour as they think proper, of what quality they think proper, and at what price they think proper. Hence the high price and the badness of the London bread. The profits go all into the pockets of the mealmen, who keep the bakers in a state of comparative slavery, and oblige the inhabitants of London to eat the worst and the dearest bread in Great Britain.

Some ingenious bakers in London, in order to make up for the smallness of their profits, have hit upon the plan of mixing potatoes with their flour, and we are credibly informed, that not less than 300 tun of potatoes are consumed for this purpose every week. Perhaps the quality of the bread is not much injured by this practice; for some of the bakers most in repute employ potatoes to a considerable extent, and the consumption of wheat is very materially diminished by it. But the grievance is, that the same price is taken for a potatoe loaf as for a loaf of the finest wheaten flour, though it must cost the baker much less.

(J.)

The reader will find some account of the substitutes which have been proposed for wheat flour, in seasons of scarcity, under the article BREAD in the *Encyclopaedia*.

BALANCE OF POWER,

AMONG States, a most important object of foreign policy, intimately connected with the general peace and independence of nations; but which some have strangely treated as altogether chimerical, and others as strangely represented as having led only to pernicious results. It is far more generally admitted, however, to have a real foundation in the principles of intercourse and union among states, and to have exercised a great and beneficial influence on the affairs of modern Europe. We say of modern Europe, because, though the policy in question was not wholly unknown to other ages and countries, it was nowhere systematically pursued, but among the nations of this quarter of the world. Previous to the sixteenth century, there was little political connection among those nations, their circumstances not being such as to admit of any regulated attention to foreign affairs; but about the commencement of that century, Europe began to be formed into one grand community or federal league, of which the actuating principle was the preservation of the balance of power. The attention to this principle thenceforth influenced all the great wars and negotiations, and made every foreign movement, however remote, an object of interest and interference throughout every part of the system.

We shall endeavour to sketch a general outline of this important subject; and, in doing so, we shall notice, though in a brief way, all the principal topics which it seems to us to present for discussion. The references which we shall frequently make to other writers, will serve both to illustrate and support our own views, and to point out the sources of more profound and complete information than we have either ability or room to give in this sketch.

General Idea of a Balance of Power, and of the System founded on it.

I. The ultimate intention of the system founded on a balance of power, is to secure every state in the full possession and enjoyment of all its rights, by making the safety and independence of every state objects of interest and guardianship to all its neighbours. It endeavours to accomplish this great end by teaching, that it is the interest of all states to check the first encroachments of ambition; to watch every movement of foreign powers; and to unite their respective forces in support of the weak against the strong. It is called the *balancing system*, because its aim is to prevent any state from aggrandizing itself to the danger of its neighbours, and to counterpoise any state that may in any way have become powerful, by a union of the forces of other states.

The metaphorical terms applied to this system seem to have given rise to some very absurd misconceptions of its true theory and purposes. It has sometimes been supposed, that its object was to equalize the powers of states composing a common system; and as it is plainly impossible either to effect, or to maintain such an equality, it has thence been concluded, that the whole system is founded upon a

chimera. But, with a view to the objects of this system, the question is, not what amount of power above another any state possesses, provided the power so possessed is fairly acquired,—but whether any state possesses its power in such circumstances as to enable it to trespass at its pleasure on a weaker neighbour. If there is no other state, or confederacy of states, capable of counteracting any injurious designs which its greater power might induce it to undertake, then it is said that there is no balance; but if there is such a counterpoise, this is all that the balancing system requires, and not an equalization of forces, to produce what, in its language, is called an equilibrium. In order to obviate such misconceptions, and to make this point as clear as possible, we beg to refer to the following definitions of the balance of power, as given by Vattel and by Gentz: “By this balance,” says the former, “is to be understood such a disposition of things, as that no one potentate or state shall be able absolutely to predominate and prescribe laws to the others.” (*Law of Nations*, B. iii. c. 3. § 47.)—“What is usually termed a balance of power,” says M. Gentz, “is that constitution subsisting among neighbouring states, more or less connected with one another, by virtue of which, no one among them can injure the independence or essential rights of another, without meeting with effectual resistance on some side, and, consequently, exposing itself to danger.” (*Fragments on the Political Balance*, c. 1.)

Thus, then, it is distinctly to be understood, that the balancing system is not grounded upon an equality among states in respect of power, but upon a union of powers to repress the enterprises of the strong and ambitious, and to counteract the effects of necessary individual inequalities by aggregate strength.

It is quite indispensable to the existence of such a system, that no one state should be permitted to obtain such a superiority of power as to enable it to overawe all opposition, and make the safety of those around it dependant on its will; and as it is the disposition of all unchecked power to extend itself, the balancing system inculcates it to be the *interest*, as it is the *right*, of every state to join in opposing the first encroachments of any ambitious potentate or community. It teaches, that the danger extends much farther than to the party immediately attacked or menaced; that one encroachment will but pave the way to another; and that it is therefore wise to meet the danger whilst yet distant, and capable of being combated with less peril or loss. The right of interference to put down a danger of this kind is, in fact, only a modification of the right to resist an immediate attack. All human experience shows, that the state which is suffered to aggrandize itself at the expence of one neighbour, will only, with its increased means, acquire stronger dispositions still farther to encroach; and, therefore, self-defence authorizes us to treat that potentate as already

Balance of Power.

Balance of Power.

dy an invader, whose conduct entitles us to conclude, that he only waits a convenient opportunity to become so in effect. It is peculiarly and emphatically the language of the balancing system,—*Obsta principis*,—in other words, look well to the safety and independence* of your neighbours, even the most remote, if you wish to preserve your own.

Upon this point it is by no means necessary to enter into any lengthened deductions. The principle of interference to prevent the progress of a dangerous power rests, both as to *right* and *policy*, upon the most obvious dictates of experience and prudence. No state ever yet acquired a preponderating power without abusing it; and, therefore, it is the right and interest of all states to prevent any one from rising to such an ascendancy as may endanger the common safety.

The right in question, however, is that of guarding against an injury justly to be apprehended from the conduct of a state, which uses improper means of aggrandizement. So far, therefore, as measures of hostility are concerned, there must be actual encroachment somewhere in order to warrant them. The balancing system does not say there shall be no alterations in the relative strength of states; for a state may fairly and honourably increase her power by wise legislation, or by the cultivation of her own internal resources. To attempt to impede a state which travels in this road to greatness, would be to make war upon those very arts by whose successful cultivation peace and happiness are spread through the world. The aggrandizements against which the balancing system declares war, are those which do immediate violence to some, and which infer farther violence to others. All that nations can do, when a neighbour becomes formidable in a fair way, is to watch her, and to draw closer those ties of alliance which may enable them to counteract any bad use of her power. When Lord Bacon, in his *Essay on Empire*, counsels princes "to keep due centinel, that none of their neighbours do so overgrow by increase of territory, by *embracing of trade*, by approaches, or the like, as to become more able to annoy them than they were;" he could not mean that the growth of a state by commerce was to be prevented in the same way as in the case of its extension by a seizure of territory; but that all great power, however acquired, is in its nature dangerous, and ought to be counterpoised by timely confederation.

There is another way in which a state may become formidable, and that of a sudden, where the balancing system does not authorize immediate hostile interference. We here allude to the case of a sovereign who acquires a great accession of power by marriage or by inheritance. "It is a sacred principle of the law of nations," says Vattel, who discusses this question in reference to the balancing sys-

tem, "that such an increase of power cannot, *alone and of itself*, give any one a right to take up arms in order to oppose it." (B. iii. c. 3. § 43.) Grotius and Puffendorf maintain the same opinion in terms equally decided. But suppose a sovereign, who has already displayed an encroaching disposition, is about to acquire in this way an accession of power, which would render him more and more formidable to his neighbours; in this case, as Vattel shows, the maxims of the balancing system authorize an immediate interference to procure securities, or, according as the danger is imminent, altogether to prevent his aggrandizement. It is perhaps wholly unprecedented, as this writer observes, that a state should receive any remarkable accession of power, without giving other states just grounds to interfere; but if it should be otherwise, the only course to be pursued is that which the balancing system always recommends—the keeping a watchful eye on all the proceedings of the formidable state, and the formation of a counterpoise to her power by means of alliances.

These are, indeed, the grand expedients of the balancing system—vigilant inspection to discover, and prompt union to counteract, in their birth, all such projects of encroachment, as powerful states, without any external limitation of their power, will ever, when opportunity offers, be ready to form. By employing resident agents to procure speedy information, and the weight of joint warnings and reclamations in every case of apprehended, or of real injury, the balancing system offers the only means which human wisdom can devise to control the conduct of independent states; and the only means which can be employed to guard against injustice, or obtain redress, without an actual appeal to the sword. It was the *habitual* employment of these expedients, with a view to guard against distant dangers, that distinguished the balancing system, as exemplified in modern Europe, from those momentary efforts and loose confederacies in which all nations, and even the rudest tribes, have occasionally united, in order to repel or pull down a powerful and common enemy.* Without this habitual attention to foreign affairs, and constant application of the principles of counterpoise, there cannot, indeed, be said to exist any thing like a system of reciprocal guarantee of the independence of nations, such as is involved in the idea of a balance of power.

What particular alliances each state ought to form, with a view to maintain this balance, is a matter of circumstances, and must vary with them. The object of the system is always the same, to preserve such a distribution of power amidst the varying relations of states, as shall most effectually check the spirit of encroachment, and confine every potentate to his own dominions.

* "The grand and distinguishing feature of the balancing system is the perpetual attention to foreign affairs which it inculcates; the constant watchfulness over every nation which it prescribes; the subjection in which it places all national passions and antipathies to the fine and delicate view of remote expediency; the unceasing care, which it dictates, of nations most remotely situated, and apparently unconnected with ourselves; the general union which it has effected of all the European powers, obeying certain laws, and actuated in general by a common principle; in fine, the right of mutual inspection, universally recognised among civilized states in the rights of public envoys and residents." Brougham's *Colonial Policy*, B. iii. § 1.

Balance of Power.

In the preceding observations, we have had it in view to give a general idea of the nature, intention, and means of maintaining a balance of power among a number of connected nations of different degrees of power and magnitude. Before proceeding to any remarks on the history and results of this branch of policy, we shall recapitulate, in the words of M. Gentz, those fundamental maxims which constitute the necessary conditions of the beneficial existence of such a system as we have described. These are,

"That no one state in the common system must ever become so powerful as to be able to coerce all the rest put together;—

"That, if the system is not merely to exist, but to be maintained, without constant perils and violent concussions, every member which infringes it must be in a condition to be coerced, not only by the collective strength of the other members, but by any majority of them, if not by one individual;—and,

"That if ever a state attempts, by unlawful enterprise, to attain, or does in fact attain, to a degree of power, which enables it to defy the danger of a union of several of its neighbours, or even of the whole, such a state should be used as a common enemy; and if it has acquired that degree of force by an accidental concurrence of circumstances, without any acts of violence, whenever it appears upon the public theatre, no means which political wisdom can devise for the purpose of diminishing its power, should be neglected or left untried." (*Fragments upon the Political Balance*, c. 1.)

Ancient knowledge of the Balance of Power, and rise of the Modern System.

II. The knowledge of the ancients in regard to these great principles of national safety, and the period when they came to obtain a decided influence among the moderns, are points of considerable historical interest. Mr Hume has shown, in a very satisfactory manner, that the principle of preserving a balance of power, is distinctly to be recognised in many of the great political transactions of the ancient nations. The anxiety of the Greeks, with regard to it, was particularly manifested in that famous league against the rising power of Athens which produced the Peloponnesian war. Athens herself showed, that she both knew and practised this policy, by constantly throwing her power into the lighter scale, when Thebes and Sparta came to contend for the mastery of Greece. Mr Hume also traces the influence of this salutary principle in the contests which arose among the successors of Alexander; their attention to it having "preserved distinct, for several ages, the partitions made after the death of that conqueror." (*Essays*, Vol. I.) The orations of Demosthenes frequently display very clear and extensive views in this branch of policy. In that

for the Megalopolitans, in particular, "we may see," according to Mr Hume, "the utmost refinements on the balance of power that ever entered into the head of a Venetian or English speculatist;" and by a later writer, this speech is also pointed out as "containing discussions of some of the most delicate parts of the theory." (*Brougham's Colonial Policy*, B. iii. § 1.) All who peruse this remarkable oration with due attention, must indeed perceive that it fully bears out this character. Its reasonings may be analyzed into these leading doctrines of the balancing system,—that it is the interest of every state to prevent the formation of a predominating power; that to this end the first encroachments ought to be promptly checked; and that it is necessary to join even a rival against a former friend, when that friend would otherwise infringe upon the balance.*

It seems, in short, to be no longer a question, that it was only with the *phrase*, and not the *idea*, of a balance of power, that the ancients were unacquainted. But we cannot agree with Mr Hume when he goes so far as to say, that this principle, though it has been more generally known and acknowledged in modern times, has not had an authority much more extensive in practice, than in the ancient world. (*Essays*, Vol. I.) This opinion stands clearly refuted by all the great facts, and by the whole tenor of modern history, from the commencement of the sixteenth century. It was the more constant operation of that principle which gradually formed the nations of Europe into one great republic or federal league, whose common bond of union was the guarantee which it afforded of their respective independence. But neither, on the other hand, can we agree with Mr Brougham, when he affirms that the ancient states displayed nothing beyond a mere speculative knowledge in this department. (*Colonial Policy*, B. iii. § 1.) † It may be very true, that those more enlarged ideas of foreign policy, which Demosthenes disclosed in some of his orations, were not generally understood or acted upon by his contemporaries; but it is nevertheless perfectly clear, from Mr Hume's statements, the accuracy of which has never been called in question, that among the Grecian states, the maxim of preserving a balance of power, though it had not produced any course of policy so regular and authoritative as the modern international system, was yet, on many occasions, the sole moving spring of their wars and alliances.

This maxim, indeed, lies so much within the sphere of common sense, that it can scarcely fail to be attended to, wherever there is a collection of states capable of observing and attacking each other. But circumstances may be more or less favourable to the growth of a consistent policy in this respect. In mo-

* There is a passage of Polybius, which has been frequently quoted, as pointing out the leading aim of the balancing system in terms the most explicit. The historian, after mentioning that Hiero, king of Syracuse, acted wisely in assisting the Carthaginians in the war of the auxiliaries, adds,—"*Nunquam enim ejusmodi principia contemnere oportet, neque tanta cuiquam astruenda est potentia, ut cum eo postea de tuo quamvis manifesto jure disceptare ex æquo non queas.*" Lib. I. cap. 83.

† It is with considerable diffidence that we venture to question any of Mr Brougham's statements upon this subject. His chapter on the *balancing system*, in the work referred to in the text, is marked by his usual extent of view and of information, and certainly constitutes a valuable portion of that very able and instructive performance.

Balance of Power.

den Europe, a number of considerable states were formed under such circumstances as tended peculiarly to promote a regular intercourse among them, and, consequently, to develop and systematize this great principle of national security. But it did not begin to manifest itself until, in the gradual and similar progress of European society, the power of the sovereigns of these states was so far consolidated as to enable them to give part of their attention to foreign affairs, and to send and maintain armies beyond their own frontiers. It was in Italy, where civilization was more advanced, and where there was a number of small states and commonwealths, whose safety required that their rulers should reciprocally keep watch on each other, that the modern system of interference took its beginnings. From an early period of the fifteenth century, we see the balance of power as constant an object of concern among these states, as, in the next, it came to be throughout Europe. "Their jealousy of each other," says Guiccardini, "made them watchful of every motion or measure that they conceived might any way increase the power of their neighbours;" and he draws a splendid picture of the beneficial effects, the long peace, and general independence attendant upon this habitual attention to the principle in question. (*History of Italy*, B. i.)

It was about the end of this century that these ideas began to extend to other quarters, and to actuate the movements of greater potentates. There were now several princes possessed of large consolidated kingdoms, with powers and prerogatives which enabled them to take part in distant wars and negotiations. The first great movement of an ambitious neighbour, would naturally therefore excite their jealousy, and bring them into concert. Thus, when Charles the Eighth of France, in 1494, invaded Italy, and laid claim to Naples, the sovereigns of Germany and Spain saw the expediency of listening to the Italian Princes, who suggested a confederacy to prevent France from gaining an accession of power, which could not but render her a dangerous neighbour. Dr Robertson regards the expedition of Charles as the first great exertion of those new powers, with which the progress of society had invested the princes of Europe; and the confederacy formed against him, as the first considerable extension of those ideas of a balance of power, whose influence had hitherto been limited to the narrow sphere of Italian politics. "From this era," he says, "we can trace the progress of that intercourse between nations, which has linked the powers of Europe so closely together, and can discern the operations of that provident policy, which, during peace, guards against remote and contingent dangers, and in war has prevented rapid and destructive conquests." (*View of the Progress of Society in Europe*, sect. 2.) If we look only a little way beyond this era, we shall everywhere see a constant jealousy of the increase of power, and a vigilant attention to all foreign operations, combined with the application of those means of safety which peculiarly belong to the balancing system. "During that triumvirate of kings," says Lord Bacon, in his usual expressive language, "Henry the Eighth of England, Francis the First of France, and Charles the Fifth, Emperor, there was such a watch kept, that none

of the three could win a palm of ground, but the other two would straightways balance it, either by confederation, or, if need were, by a war; and would not, in any wise, take up peace at interest." (*Essays—on Empire*.)

It has been objected to Dr Robertson, much to our surprise, we will confess, considering the very intelligent quarter from which the objection comes, that he has represented "the principle of the balance of power as a discovery made by the Italian politicians in consequence of this invasion of Charles; whereas, it was not to any such single event that the balancing system owed either its origin or refinement; but to the progress of society, which placed the whole states of Europe in the same relative situation in which the states of Italy were at that period, and taught them not to wait for an actual invasion, but to see a Charles at all times in every prince or commonwealth that should manifest the least desire of change." (Brougham's *Colonial Policy*, B. III. § 1.) What is here said as to the origin of the balancing system is no doubt true. We have already stated, that the principle on which it rests, is a principle of our common nature, which cannot fail to manifest itself in certain situations; but that nations must have arrived at an advanced stage of civilization and intercourse, before it can be acted upon with consistency and concert. It would, therefore, be absurd to represent that system as taking its rise in any single event, or its principle as a discovery of some long-sighted statesman. But Dr Robertson knew human nature too well to seek the origin of this principle in an accidental occurrence; and he knew history too well to fix its origin "as a consequence" of Charles's invasion. On the contrary, throughout the whole of his masterly chapter on the progress of the nations of Europe, with respect to the command of the national force requisite in foreign operations, he speaks of this system as holding progress with the growing improvement and intercourse of these nations; and so far from representing the principle of the balance of power as a discovery consequent upon the event alluded to, he expressly speaks of the league against the French monarch, as only exemplifying an extension of those ideas which had long been familiar to the Italian statesmen, "in regulating the operations of the petty states in their own country." (*View of the Progress of Society*, sect. 2.)

Before concluding these very general remarks on the rise of the balancing system in modern times, we shall briefly advert to a conjecture of M. Villers upon this subject, which occurs in his able work on the Reformation. Long before the states of Europe became united in a general system, Italy and Germany, he observes, had formed partial systems, with a view to restrain the members within them, each by the other, and thus maintain a balance of power. It is possible, he adds, that the idea of the general balance of Europe may have been copied from these partial confederacies. (*Essai sur l'Esprit et l'Influence de la Reformation*, 2de Partie.) This conjecture, if we rightly understand the learned author, appears to us exceedingly unphilosophical. The states of Europe embraced the idea of a balance of power in proportion as their circumstances enabled them to act upon it;

Balance of Power.

Balance of Power. and not in consequence of any estimate of its effects, as displayed on those earlier and narrower stages of its agency.

General Results, and recent History of this System.

III. It appears, then, to have been about the beginning of the sixteenth century that the principle of maintaining a balance of power came to be generally recognised and acted upon by the states of Europe; "at first," as M. Gentz says, "more in a practical way, and, as it were, from political instinct, but afterwards with clear, reflecting, and methodical constancy." (*Fragments.*) What were the advantages which Europe reaped from this course of policy, we shall endeavour to show, after we have adverted to certain arguments generally employed by those who wish to give an unfavourable view of the balancing system.

By some, this system is represented as productive only of sanguinary wars, as but a convenient pretext to cover projects of ambition, or to screen the restless movements of national jealousy. Others talk of it as being merely a brilliant conception; and appeal to the many violences and usurpations which modern history records, as proofs, if not of its nonentity, at least of its inefficacy. But there is surely but little respect due to that sort of estimate of the system, which is founded solely on the abuses to which it is liable, or upon imperfections from which no human institution can be made free. They who decry, or who ridicule the balancing system, should be prepared to show,—not that it has sometimes afforded plausible pretexts for unnecessary wars, or has sometimes failed to protect the weak against the outrages of the strong,—but that it is wholly useless to interest ourselves in the safety of neighbouring nations; to take any trouble to avert dangers which are yet distant; or to seek to strengthen ourselves against a powerful enemy, with any strength not our own. This view of things, were it to prevail, would, as M. Gentz observes, open the most desirable prospects to every sovereign whose power and ambition might prompt him to aspire to universal domination.

It must, we think, appear abundantly obvious to every one who reflects calmly upon the subject, that the balancing system is, upon the whole, greatly favourable to peace. The wars which peculiarly belong to it, are in the nature of a sacrifice of a smaller present, to secure a greater future good; and the tendency of the system is to render these wars less and less frequent. The evil passions which give rise to ambitious attacks, like all other evil passions, will be more apt to be indulged, the less exposed they are to opposition or restraint. And it cannot be questioned, that in proportion as the maxims of this system are vigilantly and steadily pursued, there will be less inducement, because less prospect of success to ambitious undertakings.

Its object is to alarm, and to arm all against the prince whose power prompts him to transgress upon others; and the prince who knows that all his mo-

tions are keenly watched, and that his first successes would only expose him to a more extended contest, must see how hopeless would be any attempt to possess himself of the territories even of the weakest of his neighbours. Such is the general tendency of the system; and however it may have occasionally failed to prevent outrages, it cannot be doubted, that it has proved a formidable barrier against conquest, and a rampart of defence to the weaker states.

The complaint of a certain class of French politicians, alluded to by Mr Burke, in his *Letters on a Regicide Peace*, "that Rome had frequently acquired more territory in a single year, than all the power of France, actuated by all her ambition, had enabled her to acquire in two centuries," forms, in fact, though unintended, one of the finest panegyrics that could have been pronounced upon the salutary influence of the modern system. The advocates of that system can, indeed, appeal to history for the most satisfactory of all proofs of its efficacy, in the remarkable fact, that, for a period of nearly three centuries, no European state, however small, lost its independence from external violence. When we recollect the number of small states which, during so long a period, enjoyed an independent existence on the immediate frontiers of powerful nations; and reflect for a moment on those evil passions which have, in all ages, prompted the strong to prey on the weak; we must admit that, but for that salutary jealousy of power, and united resistance to its encroachments, which it was the object and office of this system to nourish and enforce, these otherwise helpless states would have been speedily absorbed, or their independence annihilated, by the mighty masses with which they were in contact. It was not the preservation of such countries as Portugal or Holland, of Sweden or Denmark, which, though small compared with many others in the system, were yet possessed of considerable means of self-defence;—it was not the preservation of such states as these merely, but of a multitude of feeble, though happy communities, in Germany, in Switzerland, and Italy, which affords the proudest proof of the salutary influence of the balancing system on the fortunes of modern Europe. "Consider, for instance," to use the impressive words of a distinguished writer and orator, "the situation of the republic of Geneva; think of her defenceless position in the very jaws of France; but think also of her undisturbed security, of her profound quiet, of the brilliant success with which she applied to industry and literature, while Lewis the Fourteenth was pouring his myriads into Italy before her gates; call to mind that happy period, when we scarcely dreamt more of the subjugation of the feeblest republic of Europe, than of the conquest of her mightiest empire; and say, whether any spectacle can be imagined more beautiful to the moral eye, or which affords a more striking proof of progress in the noblest principles of true civilization." (*Mackintosh's Speech on the Trial of John Peltier, in 1803.*) *

* Our readers will thank us, we think, for adding the following extract, in reference to our subject, from this justly celebrated oration. "These small states were, in many respects, one of the most interesting

Balance of Power.

Such were the great and noble results of the system founded on the balance of power. It was a bridle upon the strong, and a bulwark to the weak. When it failed to prevent the inroads of violence and injustice, it yet acted as a restorative principle, and replaced injured nations in their former state of independence. It was at the memorable and fatal era of the partition of Poland in 1772 that it first lost this character,—that the first example was set of a deliberate, successful, unchecked conspiracy, against the independent existence of an unoffending country. It is here proper to mention, that some authors have spoken of this infamous transaction in terms which seem to imply, that it was quite in consonance with the principles of the balancing system.* It is indeed true, that the maxims of that system were still so far operative as to effect a relative equality in the division of the spoil. But, as the whole intention of this system is to maintain the integrity and independence of nations against unlawful attacks, the partition was just as diametrically opposite to its principle, as if the whole spoil had been appropriated by one robber, instead of being shared by three. The equality of the division did not take away from the danger of the example; the example of states combining, not to uphold but to destroy,—not to enforce respect to the great principles of national safety, but to set them at defiance; an example too soon followed by similar violences, and which, in fact, paved the way to that total overthrow of the ancient system of Europe which ere long took place.

The *origin* of a project so pernicious in its consequences is a matter of some interest in the history of the balancing system. We learn, for the first time, from Rulhiere's *Histoire de l'anarchie de Pologne*, published in 1807, that the distract-

Balance of Power.

tions of this country had suggested the project of a partition so early as 1658; that a Swedish minister, named Stippenbach, proposed it to his own court, to Austria, and the Grand Duke of Prussia, whose armies were then in possession of the country; and that it would, in all probability, have been acted upon, but for the discovery of the scheme by France, and consequent interference of that power.† With regard to the project actually carried into execution in 1772, each party concerned was desirous to shift the blame of the first proposal to the others; but it was generally believed to have originated with Frederick, though some were of opinion, that he was indebted for the idea to his brother, Prince Henry. Frederick, however, in one of his posthumous pieces, *Mémoires de 1763 jusqu'à 1775*, states, that the scheme was devised by the Empress Catherine; and this is corroborated by M. Rulhiere, who asserts that she communicated it to Prince Henry, during his visit to St Petersburg in 1770; a piece of information, he adds, which was detailed to him, in the most circumstantial manner, by three different secretaries, who accompanied the Prince to the Russian Court. (Tom. IV. p. 151, 210.) It seems to be generally acknowledged, that the proposal, when first made to the cabinet of Vienna, was opposed by that power; and that her accession would not have been obtained, but for the astonishing apathy displayed by France, and, indeed, by all the other states of Europe. The silence of England during the perpetration of this shameless plot against the independence of nations, if it can be accounted for, can never, at any rate, be excused; inasmuch as the fact appears pretty well established, that, had she, as the guardian of the political balance,

parts of the ancient system of Europe. Unfortunately for the repose of mankind, great states are compelled, by regard to their own safety, to consider the military spirit and martial habits of their people as one of the main objects of their policy. Frequent hostilities seem almost the necessary condition of their greatness; and, without being great, they cannot long remain safe. Smaller states, exempted from this cruel necessity—a hard condition of greatness, a bitter satire on human nature—devoted themselves to the arts of peace, to the cultivation of literature, and the improvement of reason. They became places of refuge for free and fearless discussion; they were the impartial spectators and judges of the various contests of ambition, which, from time to time, disturbed the quiet of the world. They thus became peculiarly qualified to be the organs of that public opinion which converted Europe into a great republic, with laws which mitigated, though they could not extinguish, ambition; and with moral tribunals to which even the most despotic sovereigns were amenable. If wars of aggrandizement were undertaken, their authors were arraigned in the face of Europe. If acts of internal tyranny were perpetrated, they resounded from a thousand presses throughout all civilized countries. Princes, on whose will there were no legal checks, thus found a moral restraint which the most powerful of them could not brave with absolute impunity. They acted before a vast audience, to whose applause or condemnation they could not be utterly indifferent. The very constitution of human nature, the unalterable laws of the mind of man, against which all rebellion is fruitless, subjected the proudest tyrants to this control. No elevation of power,—no depravity, however consummate,—no innocence, however spotless,—can render man wholly independent of the praise or blame of his fellow-men."

* See, for example, the terms in which Count Hertzberg speaks of the partition in his essay *Sur la Balance du Commerce et celle du Pouvoir*. (*Oeuvres*, Tom. I.) The language of M. Gentz upon this subject, in his able work, *L'Etat de l'Europe avant et auprès la Revolution Française*, is extremely exceptionable; but, in his later work, so often referred to in this article, he condemns the partition as wholly inconsistent with every sound idea of a balance of power, and as having in fact led to the subversion of the balancing system.

† *J'ai retrouvé*, says M. Rulhiere, *dans les archives des affaires étrangères de France, cette anecdote importante, et jusqu'à présent ignorée*. Tom. I. p. 9.

Balance of Power. raised her voice against the partition, Europe might have been saved from the fatal effects of that new system of robbery and oppression, which the spoilers of Poland were suffered, without any sort of interruption, to exemplify. "To my certain knowledge," says Mr Burke, "if Great Britain had at that time been willing to concur in preventing the execution of a project so dangerous in the example, even exhausted as France then was by the preceding war, and under a lazy and unenterprising prince, she would have at every risk taken an active part in this business." (*Thoughts on French Affairs in 1791.*)

It would lead us much beyond our limits to detail that long series of violences, and transfers of dominion, too faithfully copied from the example of the first and succeeding partitions of Poland, by which all remains of the ancient system were for a season swept from the earth. * We more gladly proceed to observe, that the time has again arrived when the nations of Europe may and ought to unite, not, indeed, to rebuild the ancient edifice in its former proportions, that being rendered impossible from the many melancholy changes which have taken place; but carefully to recal, and steadily to adhere to those great principles which constituted its foundation, and to which it owed all its beauty and strength. It is not enough to have overthrown a power which domineered over all, and to have reinstated some other powers in their pristine

strength and influence. The foundations of the ancient structure were first sapped by a shameless disregard of the sacred principles of public justice; and if the balance of power, in the full and sound acceptation of the term, is again to become an object of the foreign policy of nations, those guardian principles must hereafter constitute the rules of their conduct, in all the public transactions of Europe. Let us here again quote the words of M. Gentz, written in 1806, in a too early hope of the approaching deliverance of the Continent. He is speaking of the transition which in that event ought to follow "to a state of things founded upon a balance of power." In order to this, says he, "every just and conscientious government must set it down as an unchangeable maxim, never henceforth to lend an ear to plans which are not founded in the strictest equity. In the next place, though, in the proper sense of the term, a general code of laws cannot be framed for the regulation of a confederacy of states, at least no means should be left untried, to procure for this maxim a common sanction, and the solemn ratification of treaties. In every considerable alliance, in every treaty of peace, particularly in every congress composed of several considerable powers, the parties must mutually engage themselves not to extend their territory by unjust means; and not to enter into any scheme or association directed against the rights or possessions of an independent state, by whatever name it may be

* The following passage, though rather declamatory, contains some striking ideas as to the way in which the infamous partitions of Poland contributed to this general overthrow. "What rendered the project of a partition of Poland so incomparably more destructive to the higher interests of Europe than any former acts of violence of apparently a more aggravated character, was the decisive circumstance of its originating in that very sphere from which was expected to flow nothing but benefits and blessings, security in time of peace, and salvation in periods of danger. An union between several regents had been always considered as a beneficial barrier against lawless power, and the passions of an individual oppressor; it now appeared, to the terror of the world! that such an union could be formed for the purpose of bringing about precisely that evil against which it seemed destined as a bulwark of defence. The impression made by this detestable discovery must be still deeper and more painful, when we reflect that the framers of the wicked project, in the whole course of their undertaking, adopted the principle of the political balance as a star to conduct them through it; that they acted conformably to this principle as far as circumstances would admit, in the adjustment of their respective interests, and that while they inflicted upon its spirit the most frightful wounds, they borrowed its attire, its forms, and even its language. Corruptio optimi pessima. To witness such an abuse of the noblest mean which the European commonwealth possessed for assuring its safety and welfare, was, in itself, a revolting spectacle; but the malignant character of the deed was first completely brought to light in its consequences. The cause of public justice was on all hands abandoned and betrayed. A horde of jabbering sophists, who, at that time in France, were striving to shake the foundations of all principle, and to undermine every existing constitution, now that the mighty of the earth had broken into the sanctuary of national right, not under the impulse of incendiary passions, but deliberately and systematically, turned the most respectable political ideas into ridicule, without fear or reserve. Even among the enlightened and upright of the time, only a few escaped the dreadful contagion. Notwithstanding that what is purest in its nature may be profaned, and what is most wholesome may be poisoned—notwithstanding that the fatal blow which the federal constitution of Europe had received, called upon them the more loudly to unite, to establish the foundations of the building on a firmer basis, and more vigorously to exert themselves in its defence, they either gave themselves up to a comfortless incredulity in the efficacy of political maxims, or to a systematic indifference. The multitude, misled by the former, or not sufficiently warned against the latter, sunk every day deeper in the bottomless void, and became more and more accustomed to expect their law from violence, and their salvation from chance. How much this fatal habit of thinking must have contributed to facilitate crime, and spread desolation, when at last the evil days arrived when all right was trampled under foot, the ruin of all order conspired, and the whole social machine disjointed and broken, can have escaped only the inconsiderate observer."—Gentz's *Fragments upon the Political Balance of Europe*, p. 76.

Balance of Power.

called, whether of dividing, of rounding, of concentrating, of uniting, or of indemnifying themselves for other losses. A sort of anathema must also be pronounced by anticipation against all such as shall project such violations of right, or call upon others to assist them; so that a lively conviction may be again established in the public mind, that when princes and states enter into combinations with one another, their objects are protection and defence against common danger, never the attack and invasion of the innocent." (*Fragments*, cap. 3.) Whether these precepts of this great enemy of the late ambitious ruler of France, and advocate of those by whom he was overthrown, were taken as the guides of that "Congress of Powers," which lately met for the purposes of general pacification, we shall leave to others to determine; but thus much our present subject requires us to state, that, without a return in good earnest to those sound and salutary maxims, no durable peace is to be hoped for Europe, and no restoration of that system of balance by which Europe was so long distinguished and protected.

Interest of Great Britain in the Balancing System.

IV. We have still to allude, and we can here but barely allude, to the great question, whether Britain, protected as she is on all sides by nature, ought to consider it as a necessary part of her policy to attend to the European balance of power? This has been considered as constituting a separate question, by some who make no doubt that the other states of Europe could not long preserve their independence secure through any other course. Taking the question generally, we do not think there is any great difficulty in regard to it. With the multitude, to be sure, it always will be popular to argue, that Britain stands in need of no other defence than what the seas and her invincible navy afford her, and that all continental connexions are useless or pernicious. But the argument from the advantages of our insular situation would not in fact bear out this conclusion, even were the seas and the navy a stronger defence than it is possible they always can be. Our commerce and our colonies, the supports of that navy, render it indispensably necessary that we should more particularly observe some nations, and ally ourselves with others. These great concerns make it, indeed, nothing less than absurd to talk of our being *insulated* as an empire or state because Britain is an island. And, with regard to invasion, it is clear, that we could not always be as secure, and as free from uneasy apprehensions, in a state of total insulation from foreign connexions, as with friends and confederates to employ or oppose a formidable enemy on his own confines.

But supposing the balance of power to constitute

a great national object, the line of conduct which that object imposes upon us may, no doubt, be affected by our insular situation. We may on some occasions allow other nations who are more exposed to danger, and who ought, on that account, to be more on the alert to prevent encroachments, to take the first measures, and bear the first expence of resistance. We may watch and warn, and use the influence of our remonstrances and our counsels, without having recourse, except in urgent cases, to the extremity of arms. It is only, in a word, as to the *application* of the general principle, and not as to its being necessary and worthy to be entertained, that there seems any fair room for difference of opinion among British statesmen. In point of fact, all our later statesmen, however differing in other respects, have distinctly assented to the *general doctrine*, that the maintaining a balance of power was an interest of the highest importance to England. The last time, we believe, that this general question can be said to have been fairly brought into debate, and fully discussed in Parliament, was on occasion of the famous armament against Russia for refusing to restore Oczakow to the Porte; and on that occasion, though Mr Fox and his followers reprobated the armament in the strongest terms, they did so, not because they denied the great principle to which the minister appealed, as the sole justification of the measure, that the balance of power was a British concern, and gave Britain an undoubted interest to interfere in the affairs of the Continent,—not because they thought that Britain ought never to guard against any distant danger,—but because there was no such degree of danger from the retention of that city and its district, as called upon this country to interfere at the risk of a war.*

If there be any certain medium between the policy which Britain and other countries ought to observe with a view to the balance of power, we do not know that it can be pointed out in more specific terms than in the following passage of one of Lord Bolingbroke's political pieces, with which we shall conclude this article. "Other nations must watch over every motion of their neighbours; penetrate, if they can, every design; foresee every minute event; and take part, by some engagement or other, in almost every conjuncture that arises. But as we cannot be easily nor suddenly attacked, it may be our interest to watch the secret workings of the several councils abroad; to advise and warn; to abet and oppose; but it never can be our true interest *easily* and *officiously* to enter into action, much less into engagements that imply action and expence." (*Idea of a Patriot King.*)

* Earl Grey, the only survivor of that illustrious group of orators and statesmen who opposed the armament, repeatedly and forcibly declared his adherence to the general doctrine; affirming, that though the epithets, wild and romantic, had sometimes been applied to it, he nevertheless considered the poorest peasant in England as interested in the preservation of the balance of power; and that this country ought to interfere whenever that balance appeared to be really in danger. Of all those who joined in this opposition, Mr Burke was the only statesman who did so upon a ground, as it appears to us, equally erroneous in *fact* and *principle*, namely, that Turkey never had, nor ought to be taken into consideration, in any question as to the maintenance of the balance of power in Europe.—See *Debates in the House of Commons*, 29th March, and 12th April 1791, and 29th February, and 1st March 1792.

Baldinger
||
Balm of
Gilead.

BALDINGER (ERNEST GODFREY), a German physician of considerable eminence, and the author of a great number of medical publications. He was born near Erfurth, May 13, 1738, and was originally destined for the church; but having acquired a strong predilection for medicine, his father yielded to his wishes, and allowed him to embrace that profession, and he prosecuted his studies with this view both at Erfurth and at Jena. In 1761, he was entrusted with the superintendence of the military hospitals connected with the Prussian encampment near Torgau; and he there gave public lectures with great applause. Having acquired considerable experience in army practice, by his assiduous attention to the duties of his office, he published, in 1762, a dissertation on the diseases of soldiers, which met with so favourable a reception from the public, that he enlarged the plan of his work, and republished it under the title of *Treatise on the Diseases that prevail in Armies*, Langensalz, 8vo, 1774. It has since gone through another edition. In 1763, he was appointed professor of medicine at Gottingen, where he enjoyed considerable reputation. The Landgrave of Hesse Cassel, Frederic II. invited him to take up his abode at Cassel, conferring upon him the title of first physician to his court, and director-general of all his medical establishments. He was afterwards professor of the theory of medicine at Jena; and in 1785, was promoted to a professorship at Marburg, where he died of apoplexy on the 2d of January 1804.

His writings are exceedingly numerous; many of them are scattered in various collections and journals; but besides these, no less than eighty-four distinct treatises are mentioned as having proceeded from his pen. He had collected an extensive library, consisting of 16,000 volumes, of which a catalogue was published after his death. His funeral oration was pronounced by Professor Creutzer. He was well versed in botany, and has published several works on that branch of natural history, of which the principal are the following: *Catalogus Dissertationum quæ medicamentorum historiam, facta, et vires exponunt*. Altemburgi, 1768. 4to. *On the Study of Botany, and the method of learning it*, in German. Jena, 1770. 4to. He was for many years the editor of a periodical work, entitled *Magazine for Physicians*, 12mo, Cleves; and afterwards changed its name to the *New Magazine*, in 8vo, from 1779 to 1799. But the principal work of this kind which he conducted, was his *Sylloge Opusculorum Selectorum Argumenti Medico-Practici*, being a collection of detached essays and dissertations, which extended to 6 vols. 8vo. Gottingen, 1766—1782.

His *Litteratura universæ Materiæ Medicæ, &c.* Marburg, 1793, 8vo, is a work of great labour, but little discrimination. He edited *Barnier's Lives of Physicians*, in German. The only other work of his deserving notice, is the *Historia mercurii et mercurialium medica*. Gotting. 2 tom. 8vo. 1783 and 1785.

(w.)
BALM OF GILEAD. The earliest specifics against personal injuries resorted to by mankind, were probably the different parts of vegetables produced

Balm of
Gilead.

in their respective countries; and hence we find, that most savages are acquainted with vulneraries prepared by the hand of nature, or that they seek to improve them from decoctions and infusions of roots, flowers, and leaves. Among the more precious substances obtained from plants, applied as a curative of wounds by the ruder inhabitants of the eastern climates, the balm of Gilead, or balsam of Mecca, has been eminently distinguished during many ages. But although the balm of Gilead is better known from several scriptural allusions, and most esteemed, it is only of secondary quality to the balsam of Mecca, for which it is frequently substituted, and illustrations of its nature and properties must chiefly be derived from the latter. This balsam is a resinous matter, exuding, like ordinary resin, from incisions in the bark of two different vegetables, at least there are apparently two, though the distinction is not well characterized or described by naturalists, which has excited conjectures that there is only one, and that it is subject to certain external modifications from soil and climate. The plant producing the balsam of Mecca, was first ascertained by Forskal to belong to the genus *Amyris*. He transmitted one or two specimens to Linnæus, who has characterized it as the "*Amyris Opobalsamum*, leaves pinnate, with sessile leaflets, a native of Arabia;" while he characterizes the other "*Amyris Gileadensis*, leaves ternate, very entire peduncles, one flowered lateral, a native of Abyssinia." But, to consider it more in detail: This plant grows to the height of fourteen feet, flourishing in a hot climate, and in a stony barren soil. In general it is lower, and Mr Bruce describes a specimen five feet and a half in height, and five inches across the stem where thickest. The wood is white, light, and of open texture, covered with a smooth bark, reddish or of bluish white, resembling that of a healthy standard cherry-tree, green within, and emitting a very fragrant odour. That of the branches, which are very flexible and resinous, is equally agreeable. The leaves, which are evergreen and scanty, bear some resemblance to those of rue; and the flowers, which are leguminous, and of a purplish colour, resemble those of the acacia. The fruit consists of small pointed ovoidal berries, containing a yellowish fluid similar to honey, of a bitterish taste, and exhaling a pleasing perfume, approaching the odour of balm. This plant is called *Balissan* in the east; but it would require new botanical researches to ascertain definitely, and beyond dispute, whether it is of different species, as is most probable, and what is its real character,—points which we must consider as remaining to be established.

It has been maintained, that the plants producing the balsam of Mecca are restricted to a plantation, extending little more than 30 acres, at Beder Hunein, a station for pilgrims in Arabia, half way between Mecca and Medina. Yet it cannot be positively affirmed if this be one distinct species; that Abyssinia, the country ascribed to the other, is deprived of it; or that the balm of Gilead grows in Abyssinia exclusively. These are facts which also require elucidation in future botanical research. The

Balm of
Gilead.Balm of
Gilead.

plantation belongs to a noble family of Arabs, of the tribe Beni K'oreish, from which Mahomet originated, unless the incursions of the Wahabee, who interrupted the wonted pilgrimages, may have disposed them.

The balsam flows from incisions in the tree, which are made with an axe, in July, August, and the beginning of September, when the circulation of the sap is in the greatest activity; and it is received into a small earthen bottle. Each day's produce is collected, and poured into one of larger dimensions; but the quantity obtained is very small, and its collection tedious and troublesome; for the total exudation is usually but three or four drops in a day; nor does the most productive tree afford above sixty. Its scarcity, therefore, and the difficulty of procuring it, have no inconsiderable effect in enhancing its value. The odour is at first strong and pungent, occasioning a sensation like that of volatile salts rashly inhaled. Its intensity is proportioned to its freshness and the care it receives, for if neglected, and exposed to the influence of the air, the fragrance entirely decays. It is also of a rough, acrid, pungent taste. Originally the balsam is of a light yellow colour, a little turbid, and of a whitish cast, which is supposed to arise from the globules of air absorbed along with it; and it dissolves readily in water. It next acquires greater consistence, resembling honey, and becomes pellucid; and after the lapse of some years, grows of deeper yellow, or gold colour, when it is very tenacious, and may be drawn out in threads. It is difficult, however, to obtain the balsam in a state of purity, for several different substances are employed in its adulteration; to detect which various experiments are resorted to. If dropped into a glass of clean water, it falls to the bottom without rising again to the surface, or if remaining still on the surface, like oil in a drop, it is certainly adulterated. If, on the contrary, it spreads on the surface of the water, diffusing itself in a thin pellicle, scarcely visible to the eye, and may be collected with a thread or a feather, it is the pure and natural product. In this state it will coagulate in milk, but not if otherwise. If pure it collects in a globule, when dropped on hot iron; if adulterated it runs and spreads itself all around. The different substances used in the adulteration of this balsam are honey, wax, oil of sesamum, turpentine, and ostrich fat. Sweetness of taste betrays the honey, and its turbid appearance the presence of wax. Adulteration with oil is detected by its yielding a darker and grosser flame than what issues from the genuine balsam, when dropped on burning coals. When the consistency becomes too great, which seems a consequence of age and long preservation, fluidity is restored by the simple application of heat.

Besides the balsam now described, which is the purest and most valuable kind, and is called *Opobalsamum*, other two of inferior quality are obtained from the *balessan*; first, *Carpobalsamum*, which is prepared by expression from the fruit when it has attained maturity, and, if good, should be ponderous, of a pungent taste, and balsamic odour. Secondly, *Xylobalsamum*, which is elaborated from a decoc-

tion of the twigs. These are collected in small fagots, and sent to Venice, and the quality determining them to be the shoots of the year, is said to consist in their being knotty, the bark red, the wood white, resinous, and also exhaling balsamic odour. Various impostures are likewise practised here, in substituting spurious compounds for the real drug; and the ingenuity of mankind in this species of deception has been carried to such an extent, that detection proves extremely difficult.

Numerous virtues are ascribed to the balm of Gilead, so numerous, that modern empirics, availing themselves of that credulity which characterizes our nature in such matters, do not hesitate to offer specifics of their own invention, under the same name, with bold asseverations, that the human race will there find a palliative for most of the evils with which they are afflicted. Prosper Alpinus, one of the older naturalists, ascribes many properties to the balsam of Mecca, esteemed the most precious of all that bear the appellation of balsam, and which, in ordinary description, we must consider synonymous with the balm of Gilead; and the modern Arabs, Turks, and Egyptians, entertain great confidence in its efficacy. It is a powerful vulnerary; a quality of which Mahomet took advantage, for he affirmed, that a grove of the trees sprung up from the blood of his own tribe killed in battle, the juice of which cured the wounds of the faithful, however deadly, nay, that it recovered some of them from death itself. Hasselquist says, it is useful as a stomachic in doses of three grains. It is also taken for complaints in the breast, in fevers, and is applied for rheumatism. Its repute as an antiseptic is very great; and it is esteemed so effectual an antidote against the plague, that when this distemper makes its appearance, the Egyptians take a certain quantity daily. The balsam of Mecca, however, is principally used as a cosmetic by the eastern females of rank: after being kept in a very warm bath, the face and breast are anointed with it, and the same process is continued every third day during a month. Oil of almonds, and other cosmetics, are then rubbed over the same parts, whereby the skin and complexion are beautifully renovated. Lady Mary Wortley Montague relates, that she was induced to try the experiment; and that, in consequence, her face became swelled and red for three days, during which time, she suffered so much pain as to restrain her from repeating the application. But her complexion was greatly improved, and she adds, that the ladies of Constantinople, by whom it is used, have the finest bloom imaginable.

The balm of Gilead has been celebrated from very remote antiquity. We have the testimony of Moses, that it was an article of commerce in the earlier periods of Jewish history; for at the time Joseph was confined by his brethren in a pit, and during their deliberations on his fate, it is said, "And they sat down to eat bread; and they lifted up their eyes and looked, and behold a company of Ishmaelites came from Gilead, with their camels bearing spicery, and balm, and myrrh, going to carry it down to Egypt." Jeremiah particularly alludes to the virtues of the balm in Gilead. Josephus, however, does not

Balm of Gilead.

carry the knowledge of it so high, for he observes, the queen of Sheba or Saba, "who was inquisitive into philosophy, and on that and other accounts was also to be admired," brought the balm of Gilead as a present to Solomon, on her visit to Jerusalem, about 1000 years before the Christian era. "They say also, that we possess the root of this balsam, which our country still bears, from that woman's gift." This is not inconsistent with the words of Jeremiah, who probably flourished about 400 years later; and to reconcile those of Moses with this account, some critics have supposed that Judea did not possess the real balm of Gilead earlier than the queen of Sheba's gift, but an inferior kind of balsam,—a fact not improbable. Further, that, what was in highest esteem as the balm of Gilead, was in truth the balsam of Mecca. The best testimony of its value, is its having been the subject of royal donation among other rarities brought for the acceptance of so illustrious a prince as Solomon. It appears from the writings of the ancients, not far from contemporary with Josephus, that Judea was generally believed to be possessed of it exclusively. Pliny remarks, "but to all other odours whatsoever, is to be preferred that balsam which is produced in no other part of the world than the land of Judea, and there in two gardens only, both belonging to the king, one not exceeding twenty acres in size, and the second still smaller." Strabo, however, in the opinion of Mr Bruce, ascertained the real place of the origin of the balsam, in ascribing it to that country over or near to which the queen of Sheba reigned. "Near to this," he says, "is the most favoured land of the Sabæans, and they are a very great people. Frankincense, myrrh, and cinnamon, grow among them, and in the coast that is about Saba, the balsam also." Whence Mr Bruce observes, that "among the myrrh-trees, behind Asab, all along the coast to the Straits of Babelmandel, is its native country. It grows to a tree above fourteen feet high spontaneously, and without culture, like the myrrh, the coffee, and frankincense-tree; they are all equally the wood of the country, and occasionally cut down for fuel." Diodorus Siculus likewise affirms that this balsam grew in a valley of Arabia Felix. But Mr Bruce, who has investigated the subject with considerable care, supposes that it was towards the era of Pliny that it received its name of *Balsamum Judaicum*, or balm of Gilead; and thence became an article of commerce and fiscal revenue, which might probably operate as a discouragement to bringing it from Arabia; as also that it might be prohibited as contraband. Some centuries later than the time of those ancient authors, we see that it was known in Arabia, and perhaps in the place now most celebrated for it. A traveller who assumes the name of Ali Bey, in a very recent work, says, that there is no balsam made at Mecca; that, on the contrary, it is very scarce, and is obtained principally in the territory of Medina; as also that it was called *belsan*. As the repute of the balsam of Mecca rose, the balm of Gilead disappeared, though in the era of Galen, who flourished in the second century, and travelled into Syria and Palestine purposely to obtain a knowledge of this sub-

stance, it grew in Jericho, and many other parts of the Holy Land. The cause of its total decay has been ascribed, not without reason, to the royal attention being withdrawn from it by the distractions of the country. In more recent times, its naturalization seems to have been attempted in Egypt; for Prosper Alpinus relates, that forty plants were brought from Arabia by a governor of Cairo, to the garden there; ten remained when Belon travelled in Egypt, nearly 250 years ago; but whether from not agreeing with the African soil or otherwise, only one existed in last century, and now there appears to be none.

The balsam of Mecca has always been deemed a substance of the greatest value. When Selim, Emperor of the Turks, reduced Arabia and Egypt under his dominion in the year 1516, he exacted a tribute of three pounds weight of it yearly, which continues to be sent to Constantinople to this day. Besides this, part of the governor of Cairo's appointments include a right to receive a pound of balsam; the like quantity was due to an officer who conducted the caravan of pilgrims to Mecca; and half a pound to the Pacha of Damascus, who superintends the whole pilgrimage.

Notwithstanding the celebrity of this plant, Mr Bruce denies that it had ever been seen by the ancients, by whom he probably means the Romans, as their descriptions are so various and discordant. Prosper Alpinus, who lived in the sixteenth century, does not seem to know the real class to which it belongs, and even within these few years M. Duplessy, who has paid much attention to the exudations of vegetables, is apparently not aware of its having been figured by Bruce, and also more recently by Dr Woodville. Such uncertainties of old excited a violent dispute between the inhabitants of Rome and Venice—whether the drug used in a medicinal compound was truly the balm of Gilead; and the point being referred to the Pope, his Holiness directed that information should be obtained in Egypt, in consequence of which he decided in favour of the Venetians.

The balsam of Mecca is not the only one possessing exclusive medicinal properties, though it is, perhaps, more eminently distinguished by them. Sixteen balsamic plants of the same genus are enumerated by botanists, each exhibiting some peculiarity; and the balsam of Tolu, obtained from the incisions of a shrub growing in some of the South American provinces, is thought to approach the nearest to the virtues of the former. It is highly aromatic, a powerful antiseptic, and not less efficacious as a vulnerary. It is also very rare and difficult to be procured, which has induced impostors to offer adulterations or counterfeits under its name. That which is particularly substituted is the balsam of Peru, the product of another tree, and can be obtained in abundance either from incisions or decoction of the different parts. The secretions of these plants, however, are neither invariably odoriferous nor salutary; the balsam of Carthage exhales a penetrating disagreeable smell; and there is a low evergreen shrub, a native of North Carolina and the Bahama Islands, producing a fruit which is deadly poison, and a balsam as black as ink. (s.)

Balm of Gilead.

Baltic.

Baltic.

BALTIC SEA. The denomination of the Baltic, applied to the inland sea which forms the subject of this article, is first found in the work of Adam of Bremen, who was canon of that city at the close of the eleventh century, entitled *Chorographia Scandinavia*. The etymology of this name has given rise to many conjectures. The Swedes derive it from the Scandinavian word *Bælt*, a girdle, because its waters encircle the land; the Prussians from the Slavonian or Lettonian word *Balt*, white, from its being frozen part of the year, or from *Baltus*, one of their kings; and by others it is derived from *Baltea*, the name of an island mentioned by Pytheas, a merchant of Marseilles, who, in the second or third century before the Christian era, is supposed to have sailed as far north as this sea. In the countries which bound it, its ancient name was *Variatzkoið Morè*, or the Sea of Variaghi; by the modern Russians it is called *Baltiskoið Morè*; and by the Swedes, Danes, and Germans, the *East Sea*.

leagues in length. Its greatest breadth is 162 miles. The archipelago of Aland lies at its entrance from the Baltic, and forms three channels between the coast of Sweden and these islands. The breadth of the channel is between eight and nine leagues. This is called the Sea of Aland by the Swedes. The space between Aland and the coast of Finland is filled with numerous islands, among which are two channels. The lower part of the Gulf, from Aland to Umeo, is called by the Swedes the *Sea of Bothnia*. Between Umeo and Wasa, the channel is first narrowed by a number of rocky islands, forming a strait eight or nine leagues wide. From hence the Gulf widens very considerably, and to its head is called by the Swedes the *Gulf* of Bothnia. Its greatest ascertained depth is 50 fathoms. On the east, the Baltic forms the Gulf of Finland, which is 80 leagues long, and from 11 to 22 broad. Its entrance is between Spinthamer Point in Esthonia, and Hangø Head in Finland. Its greatest depth is 60 fathoms, which, in some places, decreases to five fathoms. A great number of rocky islands, and reefs, many of them level with the water, render the navigation of this sea extremely dangerous.

Name.

General Description.

Scagerac.

Cattegat.

Sound.

Great Belt.

Little Belt.

Extent of the Baltic.

Gulf of Bothnia;

I. The Baltic is entered from the British or Northern Ocean by the Scagerac, Cattegat, Sound, and Great and Little Belts. The Scagerac extends from the Naze of Norway and the north-west point of Jutland, to the Gulf of Gottenburgh and north point of Jutland, or Scagen Point, better known to English seamen by the name of the Scaw. The narrowest part of the Scagerac is 19 leagues. The Cattegat extends from Gottenburgh and the Scagen Point, to the Sound and Belts. The greatest depth of the Cattegat is 35 fathoms; the depth decreases as it approaches the Sound. The Sound is the channel between the coast of Sweden and the island of Zealand. A mass of rocks on the Swedish shore, distinguishes its entrance from the Cattegat; its termination is between Falsterbo in Sweden, and Cape Stevens in Zealand. Its narrowest part is between Elsinour and Helsingborg, where, measured on the ice, it is 2840 yards. Between Copenhagen and Landsrona, it is between six and seven leagues across. Its greatest depth, where narrowest, is 19 fathoms. Towards the Danish shore, at the entrance of the Sound from the Cattegat, its depth is 16 fathoms; near Copenhagen, not more than four fathoms. Near the Swedish shore, there is a gradual accumulation of sand. The Great Belt, between the islands of Zealand and Funen, is between seven and eight leagues broad, at its broadest place, between Corsør in Zealand, and Nyborg in Funen. The little island Sprogø lies nearly in the middle of it. The coasts are, in general, low and sandy; the greatest depth is 22 fathoms. The Little Belt, between Funen and the coast of Jutland, is, in its greatest breadth, about seven miles, and, where narrowest, about three quarters of a mile. In general, the shores are little elevated. Its greatest depth is 27 fathoms.

The general depth of the Baltic is 60 fathoms; but, towards its south-east extremity, and nearly in the middle, are two spots, with 110 and 115 fathoms of water. From the east mouth of the Sound to Bornholm, the depth varies from 9 to 30 fathoms; from thence to Stockholm from 15 to 50; a little south of Lindo it is 60; and among the Aland islands from 60 to 110.

It was long a generally received opinion, that the waters of the Baltic were considerably more elevated than those of the German Ocean, and that they were gradually diminishing. The first opinion seems to have rested entirely on the fact of a constant current setting out of the Baltic. To this it is ascribed by Vice-Admiral Nordenancker, who was President of the Swedish Academy in 1792. In a paper published in their *Transactions*, he maintains that, from observations made at different periods, the height of the waters of the Baltic was diminishing at the rate of about four and a half lines annually. Celsius, a learned Swede, towards the middle of the last century, advances the same hypothesis, and, from observations made on the coasts of the Baltic, he estimated the diminution at 45 inches in every hundred years. This hypothesis was supported by Linnæus, who founded on it a theory of the earth; but the chief facts brought forward in support of this opinion, viz. marks on several rocks in the Gulf of Bothnia, and the remains of vessels found at considerable distances from the present shores, by no means warrant it. M. Otto, in his physical observations on this sea, has suggested another theory to account for its apparent decrease. He supposes that, instead of really subsiding, it may be only shifting its position, and gaining in one quarter what it loses in another; and this he ascribes to the large and rapid rivers which carry along with them an immense quantity of earth and sand; and thus the beds at their mouths are raised, and their banks extended towards the sea. But recent observations made at the locks of the canal of Holstein prove, that the levels of the Baltic and the ocean are at present generally the same, and

Baltic. that the trifling differences which may be occasionally observed, are owing to accidental and temporary causes. Hence we may infer, that the constant current setting out of the Baltic, is solely owing to the abundance of the waters which it receives from its rivers.

Tides. It is generally believed that there are no tides in the Baltic. This, however, is not strictly correct. There are sensible tides in the Scagerac; they begin to diminish in the Cattegat; are very trifling in the Sound and Belts; and in the Baltic, properly so called, are scarcely, if at all, perceptible. There

Irregular Variations. are, however, irregular variations in the level of the waters of the Baltic, which bear some resemblance to tides. These elevations generally occur in autumn, when the weather threatens rain; they last sometimes a few days, sometimes several weeks. The maximum rise is three feet and a half, and the low shores are occasionally inundated. They also render the fresh-water lakes, which communicate with the sea, brackish. In the Gulf of Bothnia, the fall of the waters is usually succeeded by north winds; whereas, near Stockholm, these winds usually follow the elevation. M. Kraft, who was Professor of Experimental Philosophy in the Imperial Academy of Sciences at Petersburg, in his treatise on the inundations of the Neva at the autumnal equinox, observes, that three or four days before or after the full or new moon, a violent north-west wind drives the waters of the Northern Ocean, during the influx of the tide, into the Baltic, and is accompanied, or immediately succeeded, by a south wind in that sea and the Gulf of Finland. By Schultens, a learned Swede, who paid particular attention to the physical geography of the Baltic, the irregular elevations of this sea are attributed to the state of the atmosphere. He observed, that when the waters are about to rise, the barometer falls, and when they are about to fall, it rises. Hence he inferred, that the unequal pressure of the atmosphere on different portions of the water, deranged the level of the waters. The difference between the greatest and the least rise in the barometer in the northern parts of Europe is two and a half inches, which answers to three and a half feet of water, or the difference of the elevation of the waters at their extremes.

Superior and inferior Currents. In the Sound there are superior and inferior currents. These were first observed by some Englishmen, who, being in a boat in the middle of the channel, found that they drifted towards the Cattegat; but, having let down a loaded bucket to the depth of four or five fathoms, the boat became stationary; and when the bucket was sunk deeper, the boat drifted against the superficial current. The general currents of the Baltic are strong, and are evidently occasioned by the vast number of rivers and streams that pour their waters into it, many of which, especially towards the north, rise thrice in the course of the year. At the north extremity of the island of Bornholm, a violent agitation of the waters, or kind of whirlpool, called by the Swedes *Mali-quern*, or the grinding-mill, is occasioned by the current rushing over a circular cluster of sunken rocks. The waves of the Baltic are short and broken, in consequence of sudden changes of wind, irregular depths, and strong currents.

Saltiness. The waters of this sea are not nearly so salt as

Baltic. those of the ocean; and when the wind blows strong from the north, they become so fresh as to be fit for drinking or cooking meat. The degree of their saltiness varies in different parts, and in the same parts according to the season, or wind. According to Bergman, in his *Physical Geography*, near the south coast of Norway, at the entrance of the Scagerac, the waters contain from $\frac{1}{10}$ th to $\frac{4}{10}$ th part of their weight of salt: in the Cattegat $\frac{1}{12}$ th; in the Baltic $\frac{1}{16}$ th; and in the Gulf of Bothnia from $\frac{1}{20}$ th to $\frac{3}{20}$ th. The south-west and west winds augment the saltiness, by introducing the waters of the ocean; in the summer, it requires 300 tons of the water of the Gulf of Bothnia to produce one ton of salt, but in the winter, only 50 tons; this difference is caused by congelation, and by less fresh water flowing into it.

The analysis of three pounds of water taken up from the British Sea, on the coast of East Frizeland, and the same quantity from near Rostock in the Baltic, gave

	British Sea.	Baltic.
Muriat of soda	522	263
Muriat of magnesia	198 $\frac{1}{2}$	111
Sulphat of lime	23	12
Sulphat of soda	1 $\frac{1}{2}$	1
Residue	1 $\frac{1}{2}$	1
	746 $\frac{1}{2}$	388

The following are the results of some experiments made by Dr Thomson on the specific gravity of the water in the Firth of Forth, the Baltic off Tunabergh, the Sound, and off the Scaw Point; and also on the comparative weight of salt, obtained from 1000 grains of each of the waters evaporated.

	Specific gravity.	Weight of Salt.
Water of the Firth of Forth	1.02900	36.6
Baltic off Tunabergh	1.00476	7.4
Sound	1.00701	11.2
Scaw	1.02037	32.0

In the salt obtained from the water off the Scaw, he found

Muriat of soda	55.7
Sulphat of magnesia	25.
Muriat of magnesia	19.3
	100

Willeke ascertained that the specific gravity of the water of the Baltic was much influenced by the wind. When the wind was at East, it was 1.0039
 — West - 1.0067
 — N. W. - 1.0098
 Storm at West - 1.0118

There is great difference in the temperature in different parts of the Baltic. The general temperature of the Gulf of Bothnia in July is from 48 to 56, but it is sometimes heated to 70; the medium of the thermometer throughout the year at Uleoborgh, is 29; at Stockholm, the medium is 42 $\frac{1}{2}$. Near the land in the Gulf of Bothnia, in the month of July, the temperature of the atmosphere was observed to be 68, while the temperature of the surface of the water was 65; and in October, the temperatures were respectively 39 and 46. In the Sound, in the

Baltic. month of August, the temperature of the atmosphere was 70; on the surface of the water 68; and at three fathoms 66. On the 10th of October 1813, Dr Thomson found the temperature of the Sound to be 54. The Scagerac and Gulf of Norway are open to navigation all the winter, whereas several portions of the Baltic are covered with ice in a very moderate degree of cold; generally the bays and channels are encumbered with ice at the latter end of December. The waters towards the heads of the Gulfs of Bothnia and Finland are first frozen, and the ice being conveyed by the currents to the south, the masses of it are by the increasing cold united into vast fields, which become stationary on the west towards Stockholm, and in the east towards the Islands of Dagø and CEsel. In the southern parts of the sea, the ice begins to break up in April, but the Gulf of Bothnia and Finland often continue closed till May. The rigour of the climate in the Baltic is supposed to be considerably diminished by the clearing of the forests and the progress of cultivation; at least more intense and longer continued colds, as well as greater extent and solidity of ice, are recorded during the fourteenth and fifteenth centuries, than what have happened latterly.

then frozen.

Winds. The winds are extremely variable in the Baltic, but they blow most commonly from the east in the spring, and from the west in autumn; calms are seldom experienced, except in the middle of summer.

Fisheries of the Baltic. II. There is historical evidence, that the herring fishery was a branch of national industry in the Sound, as early as the year 1168; * and in 1389, Philip de Mezieres says, that such vast shoals of herrings crowded into the Sound, that 40,000 boats, with six to ten men each, were employed in the fishery, besides 900 large vessels, in which the herrings were salted. In the Gulfs of Flensborgh and Slie, besides what are consumed fresh, 1000 tons salted are at present annually exported to Copenhagen and Germany; and, according to the registers of the custom-house at Dalborgh, on the south shore of the Gulf of Limfiord, this city exported yearly, from 1720 to 1730, above 23,000 tons, but from 1754 to 1765, the exportation had fallen to about 8000 tons. In the year 1748, the herring first appeared in shoals in the Gulf of Gottenburgh; at first they arrived in August and September, but gradually later, and at present not till November or December. In 1752, there were 1000 tons taken; in 1753, 2000 tons; in 1761, 100,000 tons; from 1790 to 1796, nearly 2,000,000 tons were salted, and it was estimated that from 50,000 to 100,000 tons were consumed fresh.

Pilchard Fishery. Pilchards abound in the Gulfs of Bothnia and Finland, into the bays of which they arrive in shoals in spring and autumn. The pilchard fishery is one of the most important branches of industry to the inhabi-

tants on both sides of the Gulf of Bothnia. As soon as the ice breaks up, upwards of 200 families, with their children and servants, transport themselves to the rocks and islets that line the coast, where they remain fishing to the end of autumn. The annual produce of all the pilchard fisheries is estimated at 300,000 tons at least, which are entirely consumed in the Baltic.

Baltic.
Fishery.

Salmon ascend the rivers from April to June, according as they are free from ice. On the south, they abound most in the Oder, Vistula, Duna, and Narrova; on the north, in the Motala, Dalecarlia, Uleo, Kemi, Torneo, and Keymen. Salmon trout is taken in some bays of the Baltic. In the middle of the river Kemi is a small Island, where an annual salmon fair is held. The salmon fisheries of Sweden are very considerable both in the Cattegat and the Gulf of Bothnia: from 20,000 to 25,000 tons are salted annually.

Whales very rarely enter the Baltic. The common porpoise is the only one of the lesser species of cetaceous animals that lives habitually in this sea; and at Middlefart, in Funen, is a company, which enjoy the exclusive privilege of taking it. There are two varieties of the common seal, both of which are hunted, in March and April, for their oil, by the peasants of the isle of Gothland, and of the islands in the Gulfs of Bothnia and Finland.

III. The coast of the Baltic, including under that appellation the Scagerac, the Cattegat, the Sound, and the Belts, as well as Baltic Proper, may be regarded as commencing on the north side at the Naze of Norway. This is the extremity of a rocky peninsula joined to the main by a narrow isthmus; it is surrounded by rocks, of which those named the Bishop and Clerks, five miles to the south of the Naze, are most dangerous to navigators. From the Naze to the East, the shore is formed of elevated barren and dreary rocks. The principal rivers of Norway, which fall into the Scagerac and Cattegat, are the Glommen, the Laugen, the Louen, the Drammen, the Mandal, and the Nid. At the distance of five miles from the Naze is the town of Mandal, situate on the river of that name; from this place is exported a considerable quantity of smoked and salted salmon, esteemed the best in Norway. About 15 miles to the east of this is Christiansand, which has a good roadstead, besides the advantage of the little river Torvedal, to the east of the town; it exports timber, salt, fish, and iron. Arendal, the most secure and capacious harbour in Norway, formed by the Sound between the Island of Fleckerøe and the Main, succeeds. On the river Louen, is the town of Laurwig, which exports a great deal of iron from the founderies in its neighbourhood. The Gulf of Christiana lies

Coasts, &c. of the Baltic.
Norwegian Shores.

* "In the year 1238, the inhabitants of Gothia (Sweden) and Frise were prevented, by their fear of the Tartars, from sending, as usual, their ships to the herring fishing on the coast of England; and as there was no exportation, 40 or 50 of these fish were sold for a shilling. (Matthew Paris, page 396.) It is whimsical enough, that the orders of a Mogul Khan, who reigned on the borders of China, should have lowered the price of herrings in the English market."—Gibbon's *Roman Empire*, Vol. XI. p. 482. Note.

Baltic. some leagues to the east of it. This Gulf runs up into the land 20 leagues, and divides into several branches; the entrance to it is pointed out by the island of Færdar, on which there is a light. The town of Christiana stands at the top of the Gulf; its port will admit the largest vessels, there being from 30 to 40 feet water close to the quay; its exports are fir planks and rafters, pitch, tar, soap, iron, copper, and alum; they generally amount to L. 100,000 annually; the timber constituting four-fifths. There are several little villages on the Gulf, where vessels load with timber. To the east of it is a deep inlet, called Swinesund, which separates Norway and Sweden; it consists of two basins, the outer of which communicates with the inner by a very narrow strait. On the inner basin, and at the mouth of a small river, is Fredericshall, the commerce of which consists principally in the export of planks, sawed by 36 mills on the river.

**Swedish
Shores.**

The Swedish shores of the Scagerac and Cattegat are high, with a most rugged and dreary appearance, particularly near Marstrand, where the shore is lined with steep rocks projecting into the sea. The coast of Schonen forms a striking contrast to the shores of the Scagerac and Cattegat, being nearly level and free from rocks. The Swedish coast from Bleshinghar to the Gulf of Bothnia is lined with Islands and rocks, and broken into a great number of gulfs and bays. Both shores of the Gulf of Bothnia are rugged and broken; that of Sweden, in particular, forms an alpine ridge. The first river in Sweden, towards its western limit, is the Gotha, which empties itself into the Cattegat by two branches surrounding the island of Hysingen. This river, and the Motala, which falls into the Bay of Browick at Nordköping, are the only rivers of consequence in the southern provinces of Sweden. Between the provinces of Scodermanland and Upland is the lake Mælar, which communicates with the Baltic at Stockholm by two currents called the north and south; its elevation is six feet above the Baltic. The river Dahl, or great river of Dalecarlia, the Umeo, Torneo, and several others, which rise in the mountains of Lapland and Norway, fall into the Gulf of Bothnia; the northernmost are subject to three inundations annually, the first in March or April, when the snow on the low ground melts; the second towards the end of May, when the snow melts on the more elevated grounds; and the last towards the end of summer, when the thaw has reached the high lands, and dissolved the glaciers. The first commercial port of Sweden of any note is Uddevalla, a staple town; its exports are iron, planks, and herrings. The town of Marstrand, on an island of the same name, succeeds; it is also a staple, and its inhabitants are engaged in the herring-fishery, and in supplying provisions to the vessels that run in for shelter; these exceed 300 annually. The Paternosters are dangerous rocks, some miles north of Marstrand. On the southern branch of the Gotha, some leagues from the sea, is the city of Gottenburgh; the port is seldom closed by the ice, and is capable of receiving the largest ships; the harbour is about one-fourth of a mile in breadth, and is formed by two chains of rocks.

**Gotten-
burgh.**

Before the entrance of the Gotha is the island of Wingæ, with a very high light-house. The south point of the bay of Skelder is formed of a mass of rocks, lying at the entrance of the Sound, named Kullen; this mass projects far into the sea, and on the highest point, 200 feet above the sea, is a fire tower. On the Swedish shore of the Sound are several villages of little consequence. Helsingburgh, Helsingburgh, which is the usual crossing-place to Elsinour, is the only one deserving of notice. Four leagues to the southward is Landscrona, a small and ill-sheltered port, with 20 feet water; it is a staple town. The next port is Malmoe, which has a considerable trade, though its harbour is not capable of receiving vessels of any considerable burden. To the south are Skanor and Falsterbo, on the peninsular point, which forms the entrance of the Sound from the Baltic. Close to the latter is a fire tower, to direct vessels clear of a large reef, which runs off from the point. The first Swedish ports on the Baltic of any consequence are Christianstad and Carlshamn; the first is situated on the Helge, which empties itself into a gulf that separates the provinces of Schonen and Blekingen; the latter has 40 trading vessels engaged in foreign voyages; its principal export is potash, which is esteemed of superior quality. They are both staple towns. The principal part of the town of Carlsrona is built on the Island of Trosø; the rest of it on several rocky islets joined to the main by bridges. It is a staple town, and has about 40 vessels employed in foreign trade; the port is capable of holding 100 sail of the line; on one of the islands is a dock for four sail of the line. Carlsrona is the principal station of the Swedish navy. The Strait of Calmar, which is from two to three leagues broad, separates the mainland from the Island of Celand. Near the middle of the strait stands the town of Calmar, which, though not a staple, has a considerable trade, and vessels from 100 to 800 tons belonging to it. North of Calmar are several small towns on the coast, one of which, Westerwic, has some shipbuilding. In East Gothland, the province which lies to the north of Smaland on the Baltic are two considerable gulfs, Slætbacken and Browick. On the river Motala, which falls into the latter, stands the staple town of Nordköping, from which are exported considerable quantities of iron, iron-cannon, and copper, though its port can receive vessels only of light burden. From 300 to 400 enter it annually; 30 or 40 trading vessels belong to it. North of the entrance of a Sound, which communicates with lake Mælar by a canal, is Landsort Island, where is a light, and from whence ships take pilots for Stockholm.

Stockholm is built on seven or eight islands and peninsulas, at the entrance of Lake Mælar; the channel is 12 leagues long, very winding, and terminates in a basin capable of holding 1000 ships. The largest island, on which the city stands, forms two channels, through which the waters of the lake rush out with great impetuosity.

The only ports of any consequence in the province of Upland, are Grislehamn, opposite the islands of Aland, where travellers embark or take sledge for Abo, and Ceregrund, on an island in the channel of Aland, from which the iron from the founderies of

Baltic. Danemora is exported: formerly it went chiefly to England, where it was converted into steel. From Gessle, a staple town on both sides of a river of the same name, are exported considerable quantities of iron, planks, tar, and potash; its imports are corn and salt. The smaller islands in the Baltic, belonging to Sweden, have already been noticed; besides them there are Huen, Oeland, and Gottland. Huen lies in the Sound, four miles from Landscrona, three from the nearest point of Sweden, and four from the nearest point of Zealand; it is about six miles in circumference: Oeland is separated from the coast of East Gothland by the Strait of Calmar; the east coast of the island is bold and clear, but the west is dangerous for mariners. Between Oeland and a group of rocks, is the southern channel into the Strait of Calmar. Nearly in the middle of the strait is a rock, almost perpendicular, 240 feet high, surrounded by reefs. Gottland, which is 18 leagues from the nearest point of Sweden, and about the same distance from Courland, is 20 leagues long, and seven at its greatest breadth. The shore of it, in some places, is nearly perpendicular, in other places, it ascends gradually. Wisby, the capital, is built on the west coast; at present its port can receive only a few small vessels. Slitehamn, on the east of the island, is one of the best ports in the Baltic, and is defended by the fort of Carlsbelt.

Swedish Islands.

Coast of the Danish Peninsula.

The coasts, rivers, gulfs, and principal commercial ports of the south and east of the Baltic, are next to be described; and, beginning at the entrance from the German Ocean, those of Denmark first present themselves. The north point of Jutland, in the Scaw, is surrounded by a reef several leagues in extent, and on its extremity is a light-house, 64 feet above the level of the sea. The north and east coasts of this peninsula are generally low; the northern extremity is composed of sands, which are often conveyed by whirlwinds to a great distance, and do considerable damage. In order to fix them, a variety of plants, particularly the *Elymus arenarius*, sea lime-grass, are sown. The east coasts of Sleswick and Holstein descend gently to the sea. On all these coasts there are numerous gulfs and bays; the first towards the north, is the Limfiord, which nearly divides the peninsula of Jutland, being separated from the German Ocean only by a sandy isthmus, three or four miles broad; another arm of it advances southward to the town of Wybourgh, a length of about 80 or 90 miles; its entrance is two miles wide, but afterwards it becomes greatly wider; sands that very sensibly increase, and masses of granite, obstruct its entrance. In Jutland, there are also the Gulfs of Mariager, and Randers, and several bays. In Sleswick, on the Baltic side, are the Gulfs of Colding, Flensborgh, and Slie, which resembles a great river, and Ekernefiord; in Holstein are the Gulfs of Kiel, which separates this province from Sleswick, and of Lubec, and the bay of Colbergh. The Guden is the chief river in Jutland, which falls into the Baltic, at the Gulf of Randers, after a course of 40 miles; its navigation has been recently improved.

Gulfs and Bays.

Ports.

From the Scaw to the entrance of the Gulf of Limfiord, there are only small towns, chiefly inhabited by fishermen and pilots. On the north shore

of the entrance of Limfiord is the fort of Hals, where vessels, of too great depth to ascend higher, discharge their cargoes; on the south shore, four leagues and a half from the sea, is Aalborg, the chief town of Jutland. It possesses considerable commerce, its exports being corn, cattle, and fish, and 60 or 70 trading vessels belonging to it. Frederica, which stands on a promontory at the entrance of the Little Belt, has an inconvenient and badly sheltered port; the merchant-vessels passing through the Little Belt pay toll here. Colding, at the head of the gulf of the same name, which separates Jutland and Sleswick, is a commercial town, and has a port of two miles in circuit, and of depth for the largest vessels. The trade of Sleswick, which stands at the head of the gulf of Slie, has much declined: the entrance to its port being filled up with sand, a canal has been cut into it.

Baltic.

Of the Danish islands, Zealand is the principal; its length is 24 leagues, its breadth varies from 20 to 14; the Gulf of Isefiord, divided into two branches, penetrates the north side of it; at the entrance to which there is nine feet water, but it deepens within to seven fathoms. The most remarkable river in Zealand is the Nesaa, which nearly traverses it, and enters the Baltic. Elsineur, on the narrowest part of the Sound, has only a roadstead; here the duties of the Sound are paid. The origin of these duties may be traced to the middle-ages, when they were established by the sovereigns of Denmark for the support of light-houses, and the protection of the navigation of the Baltic from pirates. These duties vary from 450,000 to 600,000 rix-dollars annually. The mails and passage-boats cross the Sound from Elsineur to Helsinburgh.

Danish Islands. Zealand.

Duties of the Sound.

Copenhagen is built partly on the mainland, and partly on the island of Amak, which is separated from it by a narrow channel, crossed by two bridges. The port between Amak and the main, is one of the best in the Baltic, both by nature and art. Within are basins capable of holding 500-sail, but the entrance admits but one ship at a time. There are two royal dock-yards constructed on islands, where every ship has her particular magazine; the dry-dock is constructed of wood, and requires 20 hours to pump it out, which is done by horses. Copenhagen is a free port, and for a long time was the only one in Denmark which enjoyed the privilege of importing the produce of Iceland, Greenland, India, China, and America; and, even yet, the principal returns from these countries are made to it.

Copenhagen.

Mæen island is separated from the south-east end of Zealand by Ulfsund, a narrow strait; it is about five leagues long, and from one to three broad. It exports 15,000 tons of corn. Samsce, midway between Zealand and Jutland, is near five leagues long, and is formed of two peninsulas, the largest of which is five miles broad. The other islands belonging to the government of Zealand are of little consequence. Saltholm, in the Sound, may, however, be particularized; it is four miles long, and two broad; almost covered by the sea in winter, but in summer affords good pasturage; from it are exported to the capital, marble, freestone, and lime.

The Islands of Mæen, &c.

Funen, the second of the Danish islands in extent,

Funen.

Baltic. is 16 leagues long, and 11 broad. The Gulf of Odenzee runs considerably into it, on the north-east. At the head of it stands the town of Odenzee, the capital. From twenty to thirty trading vessels belong to it. At Nyborg, on the Great Belt, a duty is paid by all merchant vessels passing through; it is also the usual crossing-place to Zealand, and has a good port, and about as many vessels belonging to it as Odenzee. The island of Funen exports corn, and, in the year 1799, there belonged to it fifty-seven vessels above 20 tons; containing 2522 tons, with 109 men. From Rudkæbing, the only town on Langland, an island between Funen and Zealand, corn, salted meat, hides, honey, and wax are exported.

Laaland. Laaland, the third of the Danish islands in size, is 11 leagues long, and from six to eight broad. Considerable portions of its coast are so low as to be inundated during the irregular elevations of the sea. The feathers of aquatic birds and corn are its principal exports. From this island Falster is separated by Guldborg Sound, and from Mæen by Grensund. It is eight leagues long, and from one to four broad. It exports corn and fruit. In the year 1799, there were in the bailiwick of Laaland and Falster fourteen vessels, of 460 tons and 40 men. In the government of Jutland, are the Islands of Lessøe and Anholt, in the Cattegat; the latter is surrounded by dangerous banks.

Bornholm. Bornholm is an island about seven leagues and a half from the coast of Sweden, and upwards of 17 from the island of Rugen; it is eight leagues long, and five and a half broad. Its shores are composed of steep rocks, surrounded by dangerous reefs. The principal imports are coffee, sugar, and tobacco; the principal exports are salted cod, corn, poultry, and clay for the porcelain manufactory of Copenhagen, and freestone for its public buildings. The centre of commerce is at Ronne, near the middle of the west side of the Island. In 1800, this place employed 60 vessels and 130 boats, chiefly in the fisheries.

Coasts, &c. of Holstein and Lubec. The first shore on the south of the Baltic is that of Holstein, the principal port-town of which is Kiel, a place of considerable commerce. The territory of Lubec succeeds. The city of Lubec is situate on the Trave, five leagues from its mouth. Its commerce is chiefly transit, and on commission, drawing from Russia, Sweden, and Denmark, their raw commodities, and supplying them with wines, silks, cloth, hardware, and colonial goods. It admits vessels of from 150 to 200 tons. In 1802 it had from 70 to 80 merchant vessels, and the same year 1368 entered, and 1234 cleared out. Travemunde, on the mouth of the Trave, about nine miles from Lubec, is the port where vessels destined to and from Lubec take their station. The Trave, near Lubec, is joined by the Wakenitz, which, issuing from the Lake of Ratzeburgh, thus facilitates the water communication between Lubec and the interior.

Mecklenburgh. On passing the Trave, the duchy of Mecklenburgh is entered. Wismar, a bay within the isle of Poel, and Rostock, on the left bank of the Warnaw, three leagues from its mouth, are the principal commercial places in Mecklenburgh. The exports from the lat-

ter are corn, hemp, flax, hops, wax, butter, honey, cattle, apples, and feathers. **Baltic.**

The coast of Pomerania exhibits the effects of the constant action of the waters of the Baltic. On the west, the peninsula of Dars, and the Island of Zingst, form the basin called *des Dars*, which has six feet depth. The Strait of Gellen, farther east, separates the Island of Rugen from the main. This strait varies in breadth from fourteen miles to one and a quarter; the eastern entrance, called the Bodden, is navigable for the largest vessels; but in the narrows there is but three or four fathoms; and the sand accumulates so fast here, as to require a toll on all vessels passing through it, to defray the expence of clearing it.

The Gulf of Dantzic lies beyond the eastern limits of Pomerania, the western extremity of which, called the Gulf of Putzic, is formed by a curved tongue of land. On the coast of Prussia are the two remarkable basins called the Fresch-Haff and Curish-Haff. The waters of both are fresh, being supplied from the rivers of Poland, and each communicates with the Baltic by a single strait. The Fresch Haff, which, besides three branches of the Vistula, receives the rivers of Elbing, the Passarge, and the Pregel, is 16 or 17 leagues long, and from one to five broad. The communication of this basin with the Baltic has changed several times, and the present passage, near Pillau, was formed by a great storm in 1500; its depth is from 13 to 16 feet. The tongue of land called the Fresch-Nehrung, which separates it from the Baltic, commences near Dantzic, and runs east about 19 leagues; its breadth varies from one to three leagues. The Curish-Haff, or Sea of the Cures, a people of Courland, is 19 leagues long, and from one to three broad. Its depth is very irregular, and there are many sand-banks in it. Near the upper end there is no current, but in the other parts the currents are very rapid. It communicates with the Baltic by a channel near Memel 3200 feet wide, and from 11 to 13 feet deep. The spit of land which separates it from the Baltic, called the Curish-Nehrung, is about 80 miles long, in some places three miles broad, but in other places is so very narrow, that the waves of the Baltic wash over it into the basin. Its surface, which is principally sand, continually changes, by the fury of the winds. From its ancient name Mendoniemi, or promontory of Pines, it was probably covered with those trees. It is inhabited only by fishermen and pilots, whose dwellings are not unfrequently overwhelmed by the sand. It is frequented by immense numbers of crows and hawks, the former of which supply food to the inhabitants, and the title of them forms part of the revenue of the pastor.

The whole coast of Prussia and Courland is low, sandy, and covered with pebbles; the latter, however, has calcareous cliffs, which seem to run under water to the Island of Gottland. The Gulf of Livonia, or Riga, has Domes-ness for its southern limit; between which and the Swaverort is the entrance, eight leagues wide; but from Domes-ness a sand-bank runs off, and a reef from Swaverort. The coast of Livonia, and the islands off it, are in general higher than those of Courland, and are composed of sand, gravel, and calcareous strata. Entering the Gulf of Finland, on the south side, is the bay of

Gulf of Livonia.

Baltic. Roggerswic, inclosed by islands. The whole of the coast of Finland is naked, stony, lined with rocks and islets, and nearly bare of vegetation.

Rivers of Prussia. The principal rivers of Prussia that flow into the Baltic are the Oder and the Vistula. The Oder, after dividing into four principal branches, near the frontiers of Pomerania, again flows in one stream near Stettin, and falls into the Gros-Haff. Between the Oder and the Vistula several lesser rivers empty themselves; they are generally navigable, and form ports at their mouths. Three of the branches of the Vistula empty themselves into the Fresch Haff, and the fourth, which alone retains its original name, falls into the Gulf of Dantzic at Weixelmunde. The Pregel, which is deeper than the Fresch Haff, into which it falls, is navigated by vessels of considerable burden. The Elbing issues from Lake Dramsen, and, as has been already noticed, falls into the Fresch Haff. The Niemen, below Tilsit, separates into two branches, one running to the south-west, and the other to the north-west; thus both subdivide, and fall into the Curish-Haff near Memel; the Dange, which gives a port to Memel, has a short course, but is wide and deep.

Ports on the Pomeranian Shore. Stralsund is the first commercial port on the Pomeranian shore of the Baltic. Its harbour is inclosed by jetties, but its access is dangerous and difficult; on account of sand-banks. It has a considerable export trade in brandy, starch, and linens. Stettin, on the Oder, succeeds. Vessels of moderate burden go up to it, but large ones discharge at Swinemund, on the channel into the Gros-Haff, which separates the Islands of Usedom and Wollin. Between the years 1787 and 1796, the annual or whole exports were 3714 tons. The imports are manufactured goods from England, salt, wines, and fruits from France, &c. and linseed from Russia. About 160 vessels, manned by 1000 seamen, belong to it. From Politz, near the mouth of the Oder, are exported several thousand bushels of hops, chiefly to Sweden.

Islands. The principal islands off the coast of Pomerania are Rugen, Usedom, Ruden, and Wollin. Rugen is separated from the mainland by the Strait of Gellen. It is of a very irregular shape, and consists of the Island Proper, and three peninsulas. It is supposed to contain 142,000 acres. Two of the peninsulas terminate in promontories, composed of chalky cliffs, one of which is 430 feet high. There is no port on the island, but from the roads are exported herrings, cattle, corn, and salted geese. The coasts are very dangerous, scarcely a year passing in which several vessels are not stranded, and several ancient regulations are still in force respecting the assistance which the inhabitants are bound to give in case of shipwrecks. The islands of Usedom, Ruden, and Wollin, are formed by the alluvium of the Peene and the Oder; they are very low, and in general sandy.

Ports in Prussian Poland. Dantzic. Dantzic is the principal commercial place in Prussian Poland. It is situate on the western branch of the Vistula, five miles from its mouth, and at the confluence of the rivulets Motlau and Radaune. These form its port, to which there is an entrance by a canal giving a new channel to the Vistula, the old one being choked up. Dantzic has long justly been considered as one of the principal granaries of Eu-

rope. Its annual exports of corn average about 700,000 tons. Its other exports are timber, beer, brandy, horse-hair, hogs'-bristles, feathers, wool, amber, honey, wax, linens, masts of ships, cork-wood, hemp and flax, potash, salt, tar, skins, fruits, &c. Its imports are English manufactures, and London porter, herrings, fruits, lead, coffee, tea, sugar, indigo, wines, &c.

Pillau, whence there is a considerable export of Pillau timber, stands on a peninsula washed by the Fresch-Haff on one side, and the Baltic on the other. From Koningsbergh, on an island at the mouth of the Pregel, Koningsbergh. are exported nearly the same articles as from Dantzic, in between 600 and 700 vessels annually. From Elbing, at the mouth of the river of the same name, Elbing. corn, starch, linseed-oil, soap, cordage, sail-cloth, saltpetre, potash, and timber, are exported in between 300 and 400 vessels annually. The port of Memel, formerly the mouth of the river Dange, is Memel. liable to be encumbered with mud; its chief exports are, ship-timber, masts, linseed of a superior quality, hemp, flax, hides and tallow.

The first Russian river of consequence that falls into the Baltic is the Western Dwina. It is navigable Russian Rivers in Courland and Livonia, from its source to within a few miles of Riga, where ridges of rocks form fourteen falls. These, however, do not prevent the floating down of immense quantities of timber. It is frozen from the end of November to the beginning of April. It separates Courland from Livonia, and, after a course of 180 leagues, falls into the gulf of Livonia before Riga. The Narrova, which is the only outlet of Lakes Peipus and Plaskoff, falls into the Gulf of Finland at Narva, but its navigation is obstructed half a-league above that town by a fall. The Neva, which issues from Lake Ladoga, empties itself by several branches at Petersburg, above which it is from 150 to 200 fathoms broad. It is shallow, and is frozen from the end of October to the end of April. The principal rivers in Finland in Finland. are the Wuoxen, which falls into Lake Ladoga; the Kymene, into the Gulf of Finland; and the Kumo, Uleo, Kemi, and Torneo, which fall into the Gulf of Bothnia, at the towns of their respective names. In Courland, Russia has only two ports of Ports in any commercial consequence, Liebau and Windau. Courland, From the former, on a river of the same name, in the year 1800, 111 vessels cleared out, and 113 entered it; and the value of its export was 1,065,700 rubles, and of its imports 620,000. Riga and Pernau are the principal ports in Livonia. Riga is one of the Riga. most commercial cities of the Baltic, and the second in Livonia. of Russia in this respect. Its port can only receive small vessels, large ones being obliged to lie in the roads. The exports consist of corn, hemp, flax, ship-timber, pitch, potash, hides, tallow, iron, &c. The imports are woollen and cotton goods, hardware, wines, oils, and spirits, and colonial produce.

Though the entrance to Revel is through dangerous shoals, and it stands on a river which affords little or no intercourse with the interior, yet its commerce is considerable. Its exports and imports are nearly the same as Riga.

Petersburgh is built on both sides of the Neva, Petersburg. and on several islands. The mouth of the river being choked by sand, there are only from seven to eleven

Baltic. feet water over it, according as the wind blows from the east or west. With easterly winds, the river often falls three or four feet below its general level; whereas westerly winds sometimes raise it from ten to fifteen feet. Loaded ships, of any considerable burden, cannot, therefore, approach the city within four miles. The principal exports are, iron, hemp, flax, cordage, tallow, hides, linseed-oil, hemp and flax-seed, planks and rafters, leather, soap, candles, wax and honey, fish, caviar, tobacco, rhubarb, tea, isinglass, feathers, linen, and furs. The principal imports are English cotton manufactures, French wines, colours, coffee, sugar, drugs, &c.

Cronstadt. Cronstadt, the principal station of the Russian fleet, is built on a little island on the Gulf of Petersburg, four leagues below the city, the same distance from Ingria, and nine leagues from Finland. The channel to the capital is between this place and the coast of Ingria. Its navigable breadth is three quarters of a mile, its depth four fathoms. The channel between Cronstadt and the coast of Finland has only five feet water. Cronstadt has three havens, two for ships of war, and one for merchant vessels. The dry-docks, which communicate with the sea by a canal, require nine days to empty them. The principal man of war's port has space for 30 sail of the line.

Ports in Finland.

The first commercial port in Finland is Wyborgh, built on a peninsula in a gulf of the same name. It exports corn, butter, tallow, fish, fish-oil, salted provisions, timber, tar, and hops. In 1793, the value of the exports was 124,832 rubles, and of the imports 120,000. Helsingfors, the best port in Finland for large ships, is on a bay, and opposite to it is Sveaborg, the Gibraltar of the north. It occupies seven Islands, and has two basins for repairing ships of the line and smaller vessels. At the entrance of the Gulf of Bothnia, on a peninsula, stands Abo. Vessels drawing nine or ten feet go up to the town. While it belonged to Sweden, it was a staple town, with some trade to the Mediterranean, France, and Hollanú, whither it exported iron, nails, copper, deals, rafters, pitch and tar, salted provisions, hides, furs, coarse linens, and firewood to Stockholm and Copenhagen. From Abo there is no commercial place of consequence till we come to Gamla Carlby, which, in 1794, had 14 ships, of 1580 tons, thirteen of which were employed in foreign trade. Its exports that year were 1800 barrels of tar, 1500 of pitch, between 3000 and 4000 deals, 2000 lbs. of butter, 273 cwt. of tallow, and 900 barrels of corn. Brahested, a staple town, while Finland belonged to Sweden, possesses commerce nearly of the same kind and to the same amount as Gamla Carlby. It lies in a bay between two peninsulas. Uleoborg, the chief town of East Bothnia, on the Uleo, exports annually a considerable quantity of pitch and tar, butter, tallow, salmon, pike, herrings, and deals. On the Islands at the mouth of the river are two building places, from which five or six ships are launched annually. Torneo is situate on a peninsula, and had formerly a good harbour, but the accumulation of sand has almost spoilt it. The exports, besides the general articles from the other ports of Finland, are salted and smoked rein-deer flesh, and the furs of

the rein-deer, fox, wolf, and ermine, procured from the Laplanders who visit the town once a year.

The Russian islands at the north extremity of the Gulf of Livonia, Oesel and Dagoë, and the numerous Islands and rocks in the Gulf of Finland require no particular notice. The Archipelago of Aland, which was ceded to Russia along with Swedish Finland in 1809, is composed of one considerable, and above 80 lesser islands and rocks. They are in general elevated, rising in rocky peaks, with numerous caverns. The principal island is nearly round, and 20 leagues in circumference. There is no town on any of them. Besides firewood, 12,000 loads of which are sent annually to Finland and Sweden, the inhabitants export salted beef, seal-skins and oil, tallow, hides, pilchards, and butter, chiefly to Stockholm.

IV. The commerce of the Baltic is considerably facilitated and increased by means of different canals, that form a communication with different parts of it, with it and other seas, and with the interior of the countries, the shores of which it washes.

The ancient Scandinavian chronicles mention a natural water communication between the Baltic and the German Ocean, through the Danish peninsula, by means of the Gulf of Kiel, the river Lewensaw, the Lake Flemhud, and the river Eyder. When the communication ceased to be practicable, an attempt to renew it was made in the middle of the seventeenth century by the Duke of Holstein Gottorp. It did not however succeed, in consequence of the opposition of the King of Denmark. The union of Holstein and Denmark taking place in 1773, the proposed canal was begun in 1777, and finished in 1784. It enters from the Baltic by the Gulf of Kiel, near the mouth of the Lewensau, the waters of which serve to supply it. It then joins the northern extremity of Lake Flemhud, joins the Upper Eyder, passes by Rendsburgh, and falls into the German Ocean at Tonningen. The perpendicular fall towards the Baltic is 25 feet 6 inches; and that towards the ocean 23. To Lake Flemhud, which is the highest point, the vessels are drawn by horses, and elevated by three locks of nearly 10 feet fall each: three other locks lower them to the Eyder; from Rendsburgh to Tonningen the vessels use their sails. The whole length of the navigation, from sea to sea, is about 105 miles, of which the canal is about 20½; the breadth is 100 feet at top, and 64 at bottom; the least depth is 10 feet, so that it can admit vessels of about 140 tons burden. Upwards of 2000 pass it annually. The Baltic and the German Ocean are also united by means of the canal of Stecknitz. This canal unites the rivulet of that name, which falls into the Trave with the Devenau, a rivulet emptying itself into the Elbe at Lauenborg. This navigation is fit only for flat-bottom boats, and is very tedious.

The Baltic has communication with the interior of Germany, by the canals of Muhrose and Finow. The first unites the Oder above Frankfort, with the Spree, one of the tributary streams of the Elbe. The canal of Finow joins the river of this name, which falls into the Oder, with the Havel, another branch of the Elbe. By means of these and some lesser canals, a

Baltic. long navigation through Silesia, Brandenburg, Lower Saxony, and Pomerania, is maintained. There is also an artificial navigation which unites the Vistula and the Oder; this is the canal of Bromberg, which joins the Brahè, a tributary of the Vistula, with the Netze, which falls into the Warthe, and the latter into the Oder. The Niemen, in conjunction with the Dnieper, affords a communication between the Baltic and the Black Sea; the canal of Pinsk uniting the former river near its head, with the Priapetz, which empties itself into the Dnieper. These seas are also united by means of the Dwina and Dnieper. The boats employed in this navigation ascend the Dwina to the Ulla, which they also ascend as far as the Lake Beloie, out of which it flows. By crossing this lake, they reach the river Essena, which they ascend to Lake Beresina. Here they enter a canal four leagues long, which conveys them into Lake Plawia. From this lake the river Sargutsch flows, which joins the river Beresina, and this latter falls into the Dnieper; but the cataracts in this river, about 250 miles above its estuary, greatly impede the intercourse that might otherwise be established by these two navigations, between the Baltic and the Black Sea.

Of Bromberg.

Of Pinsk.

Canals of Ladoga, &c. The Baltic and Caspian Sea are united by the canals of Ladoga and Vyschnei Volotschok. The canal of Ladoga, so called, not because it enters that Lake, but as winding along its margin, extends from the river Volchof to the Neva. In the original navigation, the boats passed from the canal of Ladoga up the Volchof to Lake Ilmen, and from this lake entered the river Mašta; but in consequence of the fatal accidents that happened on the rapids of this river, one of which is six or seven leagues long, a canal was cut directly from the Volchof to the Mašta above the rapids. The old route is here only followed at a certain season, and by boats of a peculiar construction. Ascending the Mašta, the boats enter the Lake Mstinskoja, and thence the river Shlina, from which, by means of a canal with a lock, they enter the Sna, and by another lock the canal of Vyschnei Volotschok. This is a league in length, and from it a lock lowers the boats into the Twerza, which they descend to the Volga. In order to facilitate the ascending navigation from Petersburg, which is rendered tedious by the rapidity of the Volchof and the Mašta, a canal has been cut combining the Tichwin, which falls into the Lake Ladoga and the Somina, which falls into the Molaga, a tributary of the Volga. In spring the vessels may draw two and a-half feet water; but in summer only 26 inches. In autumn, the navigation from Vyschnei Volotschok to Petersburg is performed in rather more than a month; in summer, in three weeks; and in spring in a fortnight.

By these canals a navigation is established nearly the whole way from Petersburg to the frontiers of China, there being an interruption only in two places, both not more than 60 miles. The distance from Petersburg is between 1600 and 1700 leagues; but the rivers being navigable only in the fine season, it requires three years to complete the passage. The extent of the commerce is about one and a-half million of rubles annually.

Of Maria. The Baltic and the Caspian are also connected by

Baltic. the canal of Maria. The boats ascend the Neva, cross the Lake Ladoga, and enter the Swir, which they ascend to Lake Onega. From this Lake they ascend the Wytegra, which is united by the canal of Maria to the Kowska. By ascending this, they arrive at Lake Bieloe, crossing which they enter the river Tchesna, which they descend to the Wolga. A canal has long been projected to form a communication between the Baltic and White Sea; but though it was begun nearly forty years ago, there is only a short cut of about seven miles executed.

Ever since the time of Gustavas Vasa, the Swedes have been anxious to form an inland navigation between Stockholm and the Cattegat, principally in order to avoid the payment of the duties of the Sound, and Danish privateers in case of war. This navigation presented no very formidable difficulties. The Gotha flows out of Lake Venar; this is at no great distance from Lake Hielmar; and this is still nearer Lake Mælar, which communicates with the Baltic at Stockholm. Hence, it appears, that the plan of forming an internal water communication between Gottenburgh and the capital, may be divided into three principal parts: the junction of the Hielmar and the Mælar; of the Hielmar and the Venar; and the rendering the Gotha navigable from the Venar to Gottenburgh. The Hielmar is 73 feet higher than the Mælar, which is six feet above the Baltic. These two lakes were united in the reigns of Christina, Charles XI. and Charles XII., by the small river Ulvison, and the canal of Arboga. Nine locks are necessary to establish this communication. The junction of the Hielmer and Venar has been attempted, only very lately, with any hopes of a successful and speedy termination. The obstacles that opposed the navigation of the Gotha from Lake Venar, were principally just at its first issuing from that lake, at the four cataracts, 20 leagues above Gottenburgh, called by the general name of Trollhæta; the fall of Akerstream, about a mile below these cataracts, and a bed of rocks at Edit, considerably nearer Gottenburgh. The first impediment was removed in the reign of Charles IX. and XII. by the Carlsgraf Canal. Attempts were made to remove the second by carrying a canal along the channel of the river; but these not succeeding, it was resolved to cut the canal through the solid rock that forms its banks. This work was begun in 1793, and in seven years it was completed. The canal commences below the first fall of Trollhæta (for this fall, by the former plan, had been nearly turned into still water), and is carried nearly a league before it again joins the river; its breadth is 22 feet, and its depth six and a-half; it has eight locks, and a large reservoir. A communication between Lake Mælar and the lake Sodra Barken on the borders of Dalecarlia, is effected by means of the canal of Stræmsholm, some small lakes, a river, and several locks, some of which have a fall of 38 feet. A communication between Lake Mælar and the Baltic, considerably to the south of the exit of that lake, and much shorter than by it, is afforded by means of a canal that joins Lake Mælar with the Sound, at the head of which stands the town of Sæder Telje.

It is also proposed to form a communication be-

Baltic. tween the Cattegat and the Baltic, by means of the Gotha, the lakes Venar and Vetter, the river Motala, and a canal. Between these lakes are several intermediate waters, which will facilitate the communication; the Vetter empties itself by the river Motala, which enters the Bay of Browick at Nordkæeping; but, in consequence of the falls and other obstructions of this river, it will be employed only part of its course, in the intended navigation, which will be completed by a canal to the Gulf of Slætbacken, at Sæderkæeping.

Commerce of the Baltic.

V. In proportion as the maritime nations of Europe increased their navy, the commerce of the Baltic, which supplied them with flax, hemp, iron, pitch, tar, timber, and masts, flourished and extended. England and France filled their arsenals with marine stores from the Baltic; and the Dutch formed immense depots of them, not only for their own use, but to supply the nations of the south of Europe. The stimulus to the commerce of this sea was reciprocal; for the nations on its shores began to acquire a taste for the luxuries of life, wines, spices, fine woollens, cottons, silks, sweet oil, fruits, tobacco, coffee, sugar, and expensive furniture. Towards the middle of the seventeenth century, 2000 vessels passed the Sound annually. Light-houses and beacons were multiplied, companies of pilots were formed, and tribunals of commerce, banks, and exchanges, were established in the principal cities. Christian IV. was particularly distinguished for accelerating the commercial progress of Denmark at this period, though, by his war with Sweden, he weakened and diminished his territories. From the reign of Eni XIV. Sweden had gradually extended her influence and her commerce on the Baltic. Charles IX. subdued a great part of Esthonia and Livonia, built towns in Finland, and founded Gottenburgh. Gustavus Adolphus built several towns on the Gulf of Bothnia. Charles XI. encouraged the building of merchant vessels, and paid great attention to the improvement of roads and the formation of canals.

Soon after this, another maritime power appeared on the shores of the Baltic. Frederick William, the Great Elector, having acquired a part of Pomerania, and formed Prussia into an independent state, turned his attention to commerce. He attacked Sweden, annoyed her commerce, organized the ports of Prussia, and deepened and provided with pilots those of Memel, Elbing, Koningsbergh, and Pillau.

At the beginning of the eighteenth century, Russia, under Peter the Great, began to participate in the commerce of this sea. Esthonia and Livonia were united to his dominions, and Petersburg was founded. The first foreign vessel that entered the Neva was a large Dutch ship, richly laden; and her arrival gave Peter so much pleasure, that he granted her an exemption from all duties so long as she should continue to trade to Petersburg; and, by frequent repairs, she was kept in existence for more than half a century. So early as 1718, 100 Dutch ships loaded at Petersburg, and other nations soon followed their example. In the middle of the eighteenth century, the exports of Russia from the Bal-

tic amounted to twelve or thirteen millions of rubles, and her imports to about eight or ten.

During the wars which arose out of the French revolution, the commercial relations and resources of the Baltic nations have undergone a considerable change by the transference of Swedish Pomerania to Prussia; of Swedish Finland to Russia; and of Norway to Sweden. The effects which these transferences will produce, cannot yet be ascertained.

The following statements and tables, will exhibit a view of the commerce of the Baltic nations at the close of the last, and the commencement of the present century.

The Danish vessels visit the ports of Mecklenburgh and Pomerania, with horses, bullocks, butter, cheese, fish, fish-oil, colonial produce, &c.; and receive in return, thread, linen, brandy, wool, hardware, paper, &c. To Petersburg, Riga, and Memel, the Danes send herrings and dried fish, woollen manufactures, salt of France, Spain and Portugal, India and China goods, oysters, and dog-skin gloves; for which they receive potash, planks, fire-wood, flax, and hemp, cordage, iron, copper, linens, and corn. To Holland, Denmark exports rape-seed, salted and dried fish, and timber; and receives spices, drugs, corn, pipes, and paper. To England, hides, bar-iron, kelp, furs, tar, timber, &c. The returns are, hardware goods, woollens, cottons, hats, and colonial produce. From the official account of the real value of the imports into Denmark from Great Britain, from the 5th January 1798, to the 5th January 1808, laid before Parliament, in consequence of the attack on Copenhagen, it appears, that from 1798 to 1803, they are rated about half a million; and that from 1803 to 1808, they varied from two to six millions. France receives from Denmark, horses, butter, cheese, fish, &c.; and returns salt, wines, brandy, fruits, silks, &c. The exports to Spain and Portugal are nearly the same as to France; the imports also are the same, with the addition of wool and American produce. To the Mediterranean, Denmark sends fish, salted provisions, butter, iron, &c.; and receives wines, brandy, oils, fruit, and salt. The Danes derive great profit from hiring their vessels to the ports of Italy, as their flag is generally respected by the Barbary States. The exports to the Farce Islands are wheat, flour, brandy, tea, coffee, sugar, linens, &c.; the imports are dried and salted fish, fish-oil, feathers, hides, tallow, and worsted stockings. The exports to, and imports from Iceland, are nearly the same; the imports from Greenland are whale-oil and bone, seal-oil and skins, eider down; the exports nearly the same as to the Farce and Iceland Islands. Denmark has also a trifling trade to the East and West Indies.

State of the Danish merchant marine at different periods.

	No. of Vessels.	Tonnage.	Seamen.
1746	1200 to 1500	—	—
1792	3113	185,336	—
1799	- 2183	124,129	18,000
1806	2529	136,166	—
1810	1972	100,938	—

Baltic. In 1807, the Danish fleet consisted of 26 sail of the line; 16 frigates; 9 sloops, and 30 gun-vessels. **Swedish Commerce.** The foreign commerce of Sweden is confined to a certain number of ports, which have custom-houses; these are called staple towns; they are Stockholm, Gottenburgh, Warberg, Halmstad, Nordkøping, Landscrona, Carlsrona, Christianstad, Carlshamn, Calmar, Westervic, Uddervalla, Marstrand, Gefle, and Abo and Wasa in Finland, now given up to Russia. The foreign commerce is supposed to be divided among these cities, as follows:

Stockholm	$\frac{7}{13}$ ths of exports, and	$\frac{1}{3}$ of imports.
Gothinburgh	$\frac{2}{13}$ ths	$\frac{1}{3}$
The other ports	$\frac{4}{13}$ ths	$\frac{1}{3}$

Sweden exports to the foreign parts of the Baltic, iron, steel, copper, lime, alum, and herrings, and receives corn, hemp, tallow, and hides. To Holland, she exports iron; and receives spices, tobacco, prepared colours and papers. To England, she exports iron, timber, pitch, tar, potash, and herrings; her imports are lead, tin, leather, bear, butter and cheese; and every kind of manufacture and colonial produce. In France, Spain, and Portugal, the exports are iron, steel, copper and brass, and wines, brandy, fruits; oil and silks are the returns. To Italy and the Levant she exports all her territorial productions; and receives salts, spices, fruits and cotton. There are from four to six ships of 600 to 1000 tons burden in the East India trade. In 1800, she had above 2000 merchant vessels of 20 tons and upwards; but the rupture with England and cession of Finland reduced them, in 1810, to 1500. In 1809, her navy was reduced, in consequence of her wars with Russia, to 13 sail of the line, 9 or 10 frigates, and about 150 vessels of the flotilla.

Prussian Commerce. The Prussian ports, including Dantzic, export almost the whole of the commercial productions of Poland, consisting of corn, fir planks and rafters, masts, hemp, tar, pitch, potash, hides and tallow, leather, honey and wax; besides Pomeranian oak, brandy, woollens, linens, caviar, and amber. The imports are wines, coffee, sugar, tobacco, spices, salt, iron, copper, Spanish wool, herrings, and flax seed from Livonia and Courland. Towards the close of the last century, the merchant marine of the Prussian ports on the Baltic, consisted of between 900 and 1000 ships. Salted and smoked meat, hides, wool, butter, cheese, corn and fruits, are the exports of that part of Pomerania which belonged to Sweden and Mecklenburgh; the corn of the latter is principally taken off by England; that of Pomerania, as well as the fruits, used to go to Sweden.

Russian Commerce. The following table exhibits the exports and imports of Russia, so far as her commerce in the Baltic is concerned, in the beginning of this century:

	Exports.	Imports.
	Rubles.	
1802	47,000,000	33,000,000
1804	45,000,000	27,000,000
1805	52,000,000	29,000,000

The commercial marine of Russia is very small; the total number of her merchant-vessels that navigate the Baltic and the Ocean, not exceeding 50;

100 smaller vessels carry on the coasting-trade of the Baltic; and about 100 craft of 20 or 30 tons are employed in loading and discharging the vessels at Cronstadt, that cannot enter the Neva. At the close of the year 1807, the Russian Baltic fleet consisted of 20 sail of the line, 14 frigates, six brigs and cutters, and 19 small craft; and the Baltic flotilla, of 20 galleys, 25 floating-batteries, 81 gun-boats, and 16 yauls.

During the year 1815, there passed the Sound, inwards and outwards, in January, 45 ships; in February, 17; in March, 147; in April, 692; in May, 1243; in June, 1104; in July, 1476; in August, 1171; in September, 1251; in October, 783; in November, 542; and in December, 274; making a total, in the course of the year 1815, of 8745.—In the height of the season, not fewer than 100 vessels pass every four-and-twenty hours, for many weeks in succession.

See Thomson's *Travels in Sweden*; *Tableau de la Mer Baltique*, par Catteau; *Tableau des Etats Danois*, par Catteau; Macpherson's edition of Anderson's *History of Commerce*; Oddy's *European Commerce*; *Maritime Geography and Statistics*, by Tuckey, Vol. I. (c.)

BAMBOO. Privation of some ordinary substances, which attract little attention from common observers, would materially affect the convenience of entire nations. Few are wont to appreciate the incalculable value of limestone in the quarry, or iron in the pit, or even to form any conjecture of how the arts and manufactures of this country could be carried on without them. In the same manner, the bamboo, a plant of universal use in other regions, scarcely receives the slightest notice, unless when its properties, for which there is no substitute in the use of any other vegetable, are considered in detail. It is to millions in the east what the most useful raw material is to the western world.

This plant is generally ranked by botanists in the number of reeds; but some, less sensible of its analogies with them, incline to institute a separate genus for it. In the *Systema Naturæ*, Linnæus describes two species, under the genus *Bambusa*, which is characterized by "scales three, covering the spikelets, which are about five flowered; calyx none; corolla, a two valved glume; style bifid; seed one." Loureiro, who had an opportunity of studying the nature of the bamboo in its own climate, characterizes it as having "flowers with six stamina; panicle diffused, with imbricate spikelets; branches of the culm spiny; calyx one flowered." We shall abstain from discussing the more minute botanical characters, as it is to the real utility of the plant that our attention is to be specifically directed. The bamboo is a native of the warmer climates only, though growing luxuriously without the limits of the torrid zone. It rises to the height of 40, 60, or even 80 feet, with a slender hollow stem, shining as if varnished. Many, however, and probably according to the particular species, are only 12 or 15 feet high; and those which attain the greatest height here mentioned, are rather to be viewed in the same light as the overgrown vegetable productions of our own country. The stem is extremely slender, not exceeding the thickness of five inches in some which are 50 feet high, and in

**Baltic
Bamboo.**

Bamboo. others reaching 15 or 18 inches in diameter. The whole is divided into joints or articulations, separated by a short interval, called a knot or internode, and in some there is the distance of several feet between each. Small alternate branches spring from the base to the top, which, together with the narrow pointed leaves issuing from the knots, give the tree an elegant feathered appearance as it waves in the wind.

Varieties.

The rapidity of growth is surprising in the bamboo. It sometimes vegetates three or four inches in a single day. Accurate observers have seen it rise 20 feet, and as thick as a man's wrist, in five or six weeks; and it has been known to reach 30 feet in six months. This enables us to credit the assertions of those naturalists who maintain, that its full dimensions are attained in a year; and that the only subsequent change is greater thickness and induration of the wood. It is always more solid and compact towards the root, and the hollow cells of the stem become wider in proportion as they ascend. In Malabar it is said to bear fruit when 15 years old, and that it then dies. Slenderness is a distinguishing characteristic of the whole plant, and it seems probable that there are several different species which have not yet been recognised by systematic botanists. Soil and climate may have also produced effects which would disappear on uniformity of circumstances. An observer of the bamboos of China, in general, considers that there are ten species or varieties, and an observer of those in Cochin-China admits of eight. The former judges the difference to consist, first, in the size and height, for there is here the greatest disparity in those that are full grown; and it has been supposed that some, if not all species, originally spring of their ultimate diameter, which receives no accession. Secondly, The distance of the knots, or length of joint, which, in certain species of full-grown bamboo, is only four inches, while, in others young and slender, they are nine or ten feet asunder. Thirdly, In the colour of the wood, which is whitish, yellow, brown, pale blue, or speckled. Fourthly, In the size and form of the knots, some swelling out from the stem above and below; some encircling it like a cord; and those of the most singular kind, which do not penetrate within to interrupt the tubular part of the bamboo. Fifthly, By the surface and figure of the internodes being channelled or covered with tubercles; and a kind is said to exist, called the square bamboo. The varnished surface is also of different quality. Sixthly, The substance and thickness of the wood, which, varying without any relation to the dimensions of the plant, afford sufficient characteristics for constituting a species. The wood is either soft and tender, or very hard and of great strength; and the stem is either very thin and hollow, or almost totally filled up and solid, like other trees. But elsewhere, in Bangalore for example, this solidity is not ascribed to the difference of species, but to the tardiness of its growth in stony places. Seventhly, It is said that there are bamboos entirely devoid of branches, however old they may be; while others protrude as they spring from the earth. Eighthly, There is a great difference both in the hue and figure of the leaves, as also in their size; they are bluish, ash-colour, reddish, or mottled. Some are so large

as to make very good fans. Ninthly, The roots, though knotty and irregular, are found in one species to penetrate like a large tuft of filaments into the earth. Tenthly, There are certain singularities which distinguish the species of this plant, in excrescences from the knots, which may be ate; a saccharine pith; and wood of a red colour and agreeable odour.

It will easily be observed, that these remarks are too general to warrant the establishment of species from all the bamboos enumerated; but it is not improbable that a plant, so widely diffused, may consist, as before observed, of a greater number than are yet recognised.

The bamboo grows wild in most places of the east, and the warmer parts of the west, and is resorted to as occasion requires. Where the country is principally dependent on its use, it is cultivated in regular plantations; and, in more ungenial climates, preserved by the curious in greenhouses. Its culture is different, according to soil and climate; but apparently it succeeds best in low sheltered grounds, with rich, soft, spongy earth. Contact of the root with water is reputed to be immediately destructive, and too much humidity occasions gradual decay. This plant is propagated by shoots deposited in pits at the close of autumn or commencement of winter, eighteen inches or two feet deep; and if it be designed to obtain bamboos of considerable size, the scyons are cut over as they spring up. Some scrupulous cultivators among the easterns take care to preserve the plant exactly in the same position, with respect to the cardinal points, as that in which it originated. The greater the number in a plantation, the more the chance of success, as they shelter each other in their progress. Their subsequent treatment depends entirely on the uses to which they are to be converted, whether to profit or pleasure; much care being bestowed on those designed for beauty or ornament only. They are propped up with rods of a proper height, by which they are trained and supported; and, if complete plants, cut over in order to obtain suitable shoots, which are chiefly sought after; besides, this operation makes the root strike out and take a secure hold of the ground. In a rainy season, it is always necessary to surround the plantation with a ditch, in order to drain off the superabundant humidity which would otherwise be prejudicial. Various expedients are followed to obtain good bamboos, of which one of the most usual is to take a vigorous root, with firm wood, and transplant it, leaving only four or five inches above the joint next the ground. The cavity is then filled with a mixture of horse-litter and sulphur. According to the vigour of the root, the shoots will be more numerous; but they are destroyed at an early stage during three successive years; and those springing in the fourth will resemble the parent tree. It is affirmed that no culture can obtain any thing of larger size.

Scarcely has this plant been put in the ground before its utility becomes conspicuous. The soft and succulent shoots, when just beginning to spring, or only some inches long, are cut over and served up to table, like asparagus. Like this vegetable also, they are earthed over to keep them longer fit for con-

Bamboo.

Uses.

Bamboo. sumpt; and they afford a supply in succession during the whole year, though more abundantly in autumn. They are also salted and ate with rice, or prepared after different other fashions. As the plant grows older, a kind of fluid of grateful taste and odour is secreted in the hollow joints, affording an agreeable beverage, and in sufficient quantity to satisfy several persons. If allowed to remain in the tree, a concrete substance, highly valued for its medicinal properties, called *Tabaxir* or *Tabascheer*, is produced from it. The presence of the fluid is ascertained by agitating the bamboo; after some time its quantity gradually diminishes, and then the stem is opened to reach the *Tabascheer*. This substance, participating in nothing of a vegetable nature, has been supposed to be nearly allied to siliceous earths; it resists the impression of all acids, is indestructible by fire, and with alkalis forms a transparent glass. Notwithstanding its repute in the east, we are not aware that it has yet been received into the European materia medica. Besides the *Tabascheer*, many parts of the bamboo are said to be endowed with medicinal properties; a decoction of the leaves is recommended for coughs and sore-throat; the bark for fever and vomiting; the buds as a diuretic; and a compound of the root with tobacco-leaves, betel-nut, and oil, is believed to form an efficacious ointment. But setting aside its medical properties, it is highly valuable as an article of food, for many of the poorer classes in the most populous countries subsist on it in times of scarcity. The seed which it produces is recorded, in Chinese history, to have preserved the lives of thousands; the Hindoos eat it mixed with honey as a delicacy, equal quantities of each being put into a hollow joint, coated externally with clay, and thus roasted over a fire.

From the copious draught which a joint of the bamboo naturally yields, mankind are taught its use as a vessel for carrying water, and in some places no other bucket is employed. The Eastern nations build their houses solely of the wood without any auxiliary substance; if entire, it forms posts or columns; split up, it serves for floors or rafters; or interwoven in lattice-work, it is employed for the sides of rooms, admitting light and air. The roof is sometimes of bamboo solely, for which two species growing in Laos, an Asiatic country, are described to be specially adapted; and when split, which is accomplished with the greatest ease, it can be formed into lath or planks. It is employed in shipping of all kinds, and as houses are constructed entirely of it, so are complete vessels framed out of it likewise, and fitted for sea. The hull is obtained from the stem; and some of the strongest plants are selected for masts of boats of moderate size. In Bengal, a boat of four or five tons may be furnished with both mast and yard from the same bamboo, at the cost of threepence; and the masts of larger vessels are sometimes formed by the union of several bamboos built up and joined together. Those of considerable dimensions are used in the higher yards of ships of four or five hundred tons, for which service they are well adapted by their great strength and lightness.

The bamboo is employed in the construction of

all agricultural and domestic implements; and in all materials and implements required in fishery, hooks and nets excepted. In Tibet the strongest bows are made of it, by the union of two pieces with many bands; and in the same country also, it is employed, as we use leaden pipes, in transmitting water, for the distance of several miles, to reservoirs or gardens. The species from which these pipes are constructed is said to grow in the mountains; and from other light and slender stalks, the inhabitants obtain shafts for their arrows. In the south-west of Asia, there is a certain species of equally slender growth, from which writing-pens or reeds are made.

From the extreme flexibility of this substance, and also its divisibility, for it splits like whalebone from top to bottom, it can be reduced to the smallest dimensions, and bent into every shape. It is woven into baskets, cages, hats, or various ornamental articles. By a particular process in bruising and steeping the wood or bark, a paste is procured that is made into paper. In short, from its very origin until its decay, it never ceases to produce something beneficial. It has justly been observed, "All that composes a bamboo is profitable, of whatever species it may be. The artists of China have each made their choice, and in the works they produce, show the advantage they have derived from it. Its uses are so numerous, so various, and so beneficial, that it is impossible to conceive how China could now dispense with this precious reed. It is no exaggeration to affirm, that the mines of this vast empire are of less importance to it than possession of the bamboo."

It has been proposed to naturalize the bamboo in France. Perhaps were the naturalization of plants and animals attempted by slow and regular gradation, instead of great and sudden transition, experiments might be more successful than former practice would authorize us to conclude. Probably it would require the renewal of several successive generations, each advanced into a different climate not remote from the abode of the one which preceded it, before naturalization could be completely effected. Some European climates might not prove noxious to the bamboo; but the same rapidity of vegetation, the same natural qualities, could not be expected, or only in an inferior degree, even in the most favourable situation, and consequently its utility would be infinitely diminished. (s.)

BANDA ISLANDS. These Islands, situate 130 miles to the south-east of Amboyna, are ten in number, viz. Banda Neira, Gonong Apee, Banda Lantoir, Pulo Ay, or Way, Pulo Rondo, or Pulo Roon, Rosyngan, Pulo Pisang, Craka, Capella, and Sonangy. Description and History of these Islands.

Of these, Banda Neira is the seat of the supreme government, and it is secured by one principal fortification, situate on the south side of the Island, consisting of a small square fort, having a wet ditch, with a horn-work towards the sea. This fortification, which is called Fort Napau, forms the chief defence of the Banda Islands. The troops are quartered, and the public granaries are kept in this fort; but the storehouses for the nutmegs and mace are on the outside, as well as the government-house.

Bamboo
||
Banda
Islands.

Banda
Islands.

Above Fort Napau, on a neighbouring eminence, stands the castle of Belgica, an old pentagon, with round towers at the angles. It is surrounded with a wall, secured by small bastions, but has no ditch, and is said to have been built by the Portuguese.

Banda Lantoir, or Great Banda, is to the northward of Banda Neira. It is defended by a considerable fort, which commands the harbour of Lantore, and is called Fort Hollandia. At first view, the situation of this fort appears preferable to Banda Neira for the residence of government, not only on account of its strong and commanding situation, but because the Island is the largest, as well as the richest, in the produce of spices. Its unhealthiness has been found, however, to be a sufficient objection. The water is said to be bad, and the vapour which sometimes descends from the volcanic mountain of the neighbouring Island Gonong Api, is represented as particularly noxious. Such fatal effects were produced by these causes, that when the Wirtemberg Company formerly garrisoned the Island, out of a hundred men, eight died, and forty fell sick, in the course of two months. The numbers of decayed houses, also, which are seen in different parts of the Island, show that the experiment of a settlement has been already tried, and has not been found to answer. This Island appears very high from the sea; its sides are steep, and from the top of them there is a sort of table land, which extends nearly from one end of the Island to the other.

Gonong Apee is to the northward of Banda Neira, and derives its name from a large volcano, about 2000 feet above the level of the sea, which constantly emits smoke, and sometimes cinders and ashes, accompanied with a crackling noise. On the south side of this Island are two forts, originally intended to defend the west channel of Lantore harbour; but owing to an eruption of the volcano in 1778, at the same time that a dreadful hurricane laid waste the Island, the lava flowed down in such quantities as to form a considerable promontory between these batteries and the channel they were intended to defend, so that they are now in a great measure useless. This Island is generally unproductive, its surface being covered with a quantity of sulphur and chalk. There is no vegetation whatever on upwards of one-third of the eminence on which the volcano is situate. Towards the sea, the descent is exceedingly steep; but towards the harbour, the declivity slopes gradually to the water, on the side of which are some plantations, and a few straggling houses.

Pulo Way is about nine miles to the westward of Gonong Apee, and is defended by a strong fort. It is esteemed the most healthy of the whole group, and produces abundance of nutmegs, of a kind superior in quality to those of the other Islands. Pulo Rondo, or Pulo Roon, is about four miles further in rather a more northerly direction. On this Island the English had a factory, from which they were expelled by the Dutch, about the period of the massacre of Amboyna; and the Island having been since abandoned, has become a wilderness. Rosyngen is about seven miles to the south-east of Lantore. It produces nutmegs, mace, yams, and subsistence for a few cattle. The convicts of Amboyna were for-

merly kept on this Island, and were compelled to cultivate the land for the use of the supreme government. Pulo Pisang is about two miles north-east from Banda Neira, and yields some fine fruits, as well as nutmegs and mace. The other three Islands are uninhabited, being little more than barren rocks.

The Banda Islands were discovered in the year 1511 by the Portuguese, who immediately took possession of them in the name of their sovereign. About the year 1603, they were expelled by the Dutch. In 1608, the English, with the permission of the king, built a factory-house on Pulo Way, which the Dutch demolished as soon as the ship which brought out the factors returned to England. The natives of Banda, notwithstanding the opposition of the Dutch, assisted the English in forming a new colony, and shortly afterwards they, along with the natives of Lantore, made a formal resignation of their respective Islands to the new settlers. In 1620 Pulo Roon and Pulo Way were added to the English dominions, and those cessions were confirmed by a treaty concluded between the English and the Dutch. But, in defiance of this treaty, the latter determined on the expulsion of their rivals from those Islands, in the possession of which they appeared to be gradually establishing themselves. They accordingly attacked them with a strong force, seized their factories, magazines, and shipping, and after stripping the factors naked, first whipped and then loaded them with irons. Some notion may be formed of the trade, then in its infancy, by the quantity of spices seized here, which amounted to 23,000 lbs. of mace, and 150,000 lbs. of nutmegs. In 1654, the Dutch were compelled, by the firmness of Cromwell, to restore the Island of Pulo Roon, and to make satisfaction for the massacre of Amboyna. But the English settlers not being adequately supported from home, were unable to resist the power of their rivals, and the Island was retaken by the Dutch in 1664. They retained undisturbed possession of their conquests in this quarter of the globe until the year 1796, when the Banda Islands, along with all the other Dutch colonies, were conquered by the British. They were restored by the treaty of Amiens, in the year 1800, but were again captured, and have been again restored, by the treaty of Paris, concluded in the year 1814.

In the space between Banda Lantoir and the Islands of Banda Neira and Gonong Apee, there is a very good harbour formed with entrances both from the east and west, which enable vessels to enter it from either of the monsoons. These channels are well defended with several batteries, particularly the western one, which is very narrow. Between Gonong Apee and Banda Neira, there is a third channel into this harbour from the north; but it is navigable only for small vessels.

The great articles of commerce in these Islands are nutmegs and mace, which are engrossed at a fixed price, for the benefit of the Dutch East India Company, and the laws and regulations generally established, are calculated to support and promote this monopoly, rather than the happiness of the people, or the improvement of the country. With this view, the cultivation of the nutmeg is only allowed in the

Banda
Islands.Culture,
Varieties,
and Com-
merce of
the Nut-
meg.

Banda
Islands.

Islands of Banda Neira, Gonong Ap, Banda Lantoir, and Pula Ay. In all the other Islands the tree has been carefully extirpated, because, being at a distance from the seat of government, they were supposed to afford better opportunities for smuggling. In the Islands which are appropriated to the cultivation of the nutmeg, they neither feed cattle nor produce grain sufficient for the maintenance of the inhabitants, and they are on this account dependent on Batavia for annual supplies of rice, and other articles of provision. In consequence of the low state of agriculture occasioned by this policy, the inhabitants are few, and the number of hands that would be necessary to bring the nutmeg plantations into the highest state of cultivation, cannot be procured. This scarcity of hands renders it necessary to recruit the declining population by the importation of slaves. It would appear, also, that the inhabitants suffer severely when the supplies of provisions on which they depend from abroad happen to be interrupted, and that, in these circumstances, their wants subject them to the greatest oppressions. About fifteen months before these Islands were last conquered by the British, some reforms in the system of administration were carried into effect by a new governor who had been appointed for that purpose. But before this period most of the planters were in great distress, having been charged with very heavy debts, incurred on account of loans in rice and money, made at different periods by the former governors, and this circumstance, joined to the great loss which they sustained by the dreadful hurricane of 1778, entirely ruined their private fortunes as well as their plantations. While they were in these distressed circumstances, the Dutch government, with an unfeeling avarice, aggravated their misery by compelling them to deliver their nutmegs, at the reduced price of three farthings *per* pound, and the mace at a still lower rate. Under this accumulated distress, the spirit which had animated their fathers in the days of their independence seemed once again to revive, and they remonstrated in bold and determined language. They claimed the lands as their own prescriptive inheritance, which they undoubtedly were, and actually proceeded to portion out their respective properties to each other. The Dutch, though they were touched by no feeling for the deplorable situation to which they had reduced the country, were nevertheless alarmed when they saw their discontented subjects determined to resist, and it was thought advisable to adopt a more just and conciliatory conduct. With this view, the accumulated arrear of debt claimed by the company from the planters, and which most of them were unable to pay, was cancelled. Several judicious regulations were also adopted regarding the management of slaves, and the price at which the government received the spices of the planters, were at the same time increased from the low rate to which it had been reduced to seven and a half stivers *per* lib. for mace, and to two and a half stivers for nutmegs, with a deduction of 17 *per cent.* in favour of the company and their servants.

In return for these concessions, it would appear, that the company, after having pacified their subjects, seized their lands, and in this manner they continued

Banda
Islands.

to practise the same oppression as before, though the mode of it was somewhat different. The planters in general, if they had been once freed from the enormous debt claimed by government, would, from the produce of their plantations, have speedily discharged all other claims, and they considered it hard, therefore, that, under colour of remitting this debt, they should be deprived of their respective properties, to which prescription gave them an undoubted right.

The nutmeg-tree is a native of several of the Islands to the eastward; but it has been in a great measure extirpated from them all except Banda. It begins to bear fruit at ten years growth, the fruit improving in quality, and increasing in quantity, until the tree has attained the age of an hundred years. In its appearance it is handsome and spreading, the bark is smooth and of a brownish grey colour. The leaves resemble those of the laurel, and afford, when bruised, a grateful aromatic scent. When the tree first begins to produce fruit, little yellowish buds make their appearance, out of which small white flowers are blown, two or three hanging upon slender peduncles. In the centre of the flower is an oblong reddish knob, from which the fruit is produced, though no more than one blossom out of three commonly ripens to a nutmeg. It is eight or nine months before the fruit arrives at maturity; but blossoms and ripe fruit are found together on the same tree, and the nutmegs are generally gathered three times in a year. The nutmeg, when ripe on the tree, has both a very curious and beautiful appearance. It is almost the size of an apricot, and nearly of the same colour, with the same kind of hollow mark all round it. In shape it is somewhat like a pear. When perfectly ripe, the rind over the mark, which is nearly half an inch thick, and of a whitish colour, opens, and displays the nutmeg in its black and shining shell, encircled by a net-work of scarlet mace. The shell in which the nutmeg is inclosed is about as thick as that of a filbert, and very hard. In preparing the fruit for use, the mace is first stript off and kept in baskets to dry in the sun, and the nutmeg in its shell is placed before a slow fire to dry in five different houses made of split bamboos, fitted up for the purpose. In each of these houses it remains a week, till it is heard to shake within the shell, which is then easily broken. The nutmegs thus prepared are sorted into separate parcels. Each sort is put up by itself into baskets, and soaked three times in tubs of sea water and lime; after which they are put into distinct closets, where they are left for six weeks to sweat, that the lime, by closing the pores of the nutmeg, may prevent its strength from evaporating. The lime is necessary to preserve the fruit from worms and other insects, and it requires much experience, as well as a considerable degree of judgment, to ascertain the precise time that the fruit should be suffered to remain in the lime; for, if it be taken out too soon, it is worm-eaten, and if it is left to remain too long in the lime, it is burnt up and rendered useless.

The nutmeg is distinguished into three sorts, namely, the male or barren nutmeg, the royal nutmeg, and the queen nutmeg. The two last species are distinguished by the different sorts of fruit which

Banda
Islands.

they produce, that of the royal nutmeg being thicker, longer, and more pointed. The green shell is also thicker. It does not ripen so fast; and after opening, it preserves its freshness eight or nine days. The mace is more substantial, and three times as long as that of the queen nutmeg, and its stripes or thongs, of which there are from 15 to 17 principal ones, are of a livelier red; they are also broader, longer, and thicker, and not only embrace the nut through its whole length, but pass it, and cross under it as if to prevent it from falling. The royal nutmeg is generally from 15 to 17 lines long, and thick in proportion. It remains on the tree a long time after the opening of the green shell, and gives birth to an insect in the shell, which feeds upon it, and destroys it. The queen nutmeg produces much smaller nuts, only nine or ten lines long, not so thick by a third, and well marked by a longitudinal groove on one side. They are round, and the green shell is not so thick. The mace, which is composed of nine or ten principal stripes, grows only half down the nut, thus leaving it at liberty to detach itself, and to escape from the insect formed in the shell. In two or three days, also the green shell, losing its freshness, soon falls away from the nut.

Nutmegs should be chosen large, round, heavy, and firm, of a lightish grey colour on the outside, and the inside finely marbled, of a strong fragrant smell, warm aromatic taste, and a fat oily body. The oblong kind, and smaller ones, should be rejected. The real quantity of nutmegs produced has never been exactly ascertained. The largest quantity sold by the Dutch East India Company at one time was 280,694 lbs. in the year 1737. In 1766, there were sold 241,427 lbs. and in 1778, 264,189 lbs. The average quantity annually sold in Europe has been stated at 250,000 lbs. exclusive of about 100,000 lbs. disposed of in the East Indies. The produce, however, has since greatly declined, which may be imputed to various causes. In the year 1778, the nutmeg plantations were laid waste by a tremendous hurricane, and this calamity was succeeded by oppressions on the part of the government, and by disturbances among the people; agriculture and industry were in consequence neglected, and the annual produce of spices of all sorts, which amounted to 600,000 lbs. was suddenly reduced to 50,000 lbs. For seven years previous to the commencement of the war with France in 1793, the average quantity of nutmegs sold in Holland amounted only to 22,459 lbs. and that of mace to 7504 lbs. When Banda was taken by the English in 1796, the quantity of spices in the warehouses amounted to 84,777 lbs. of nutmegs, and to 19,587 lbs. of mace. In the several years of 1803, 1804, and 1805, when the Banda Islands were in possession of Britain, there were imported of nutmegs 104,094, 117,936, and 35,851 lbs., which were sold for L. 46,233, L. 54,733, and L. 23,742. The quantity retained for home consumption amounted on an average to 39,071 lbs. *per annum*, and the revenue which they yielded to L. 7879. The permanent duty levied on nutmegs in this country is 3s. 6d. *per lib.*; and the war duty 1s. 2d., making together 4s. 8d. *per lib.*

Of mace, the quantity consumed in Britain was

5

Banda
Islands
Bandello.

decreased since the establishment of the East India Company. In the year 1615, the consumption amounted to 15,000 lbs. In 1803, when the Islands were in possession of Britain, the whole quantity only amounted to 24,234 lbs., and the sole value was L. 53,356. The quantity retained for home consumption was, on an average, from 1804 to 1809 inclusive, 5400 lbs. *per annum*. The duty on mace imported is 7s. 8d. *per lib.* Mace should be chosen fresh, rough, oleaginous, of a fragrant smell, a bright reddish yellow, and the smaller pieces are esteemed the best. See Milburn's *Oriental Commerce*, and the *Asiatic Annual Register*. (o.)

BANDELLO, a celebrated Italian novelist, was born at Castelnuovo, in the neighbourhood of Tortona, about the year 1480. In his youth, he studied both at Rome and at Paris; and his education being completed, he went to reside at Mantua. There he remained for several years much esteemed by Pirro Gonzaga, who entrusted him with the education of his daughter, the celebrated Lucrezia Gonzaga. The incidents in the lives of literary men, who flourished in Italy during the sixteenth and seventeenth centuries, have a strong similarity to each other. Like most of his literary contemporaries, Bandello passed from one petty court to another, and was frequently employed in political missions by the patron whom he served at the time. At this period, the small states of Italy were divided between the French and Spanish interests. Bandello had chiefly attached himself to those princes of Lombardy who favoured the French party; and, in consequence, when the decisive battle of Pavia put the Spaniards in possession of Milan, where Bandello at that time resided, his paternal mansion was burned, and the property of his family confiscated. He fled in disguise from Milan, and after wandering from town to town, he placed himself under the protection of Cesar Fregoso, a celebrated captain of that age, who had recently quitted the Venetian for the French service. With this general Bandello resided in Piedmont, till a truce was concluded, when he accompanied his patron to France. After the death of Cesar he continued to live with his widow and family at Agen, to the Bishoprick of which he was raised by Francis I. in 1550, and continued to reside in the vicinity of that town till his death, which happened about 1562.

During his residence at Agen, Bandello revised and added to his Novels, which he had written in Italy during his youth, and which some of his friends had recovered from the hands of the Spanish soldiers, who burned his house at Milan. His *Tales* were first published at Lucca in 1554, 4to. In the complete editions of Bandello, the work is divided into four parts—the 1st, 2d, and 3d parts, containing 59 stories, and the 4th comprehending 28. The whole are dedicated to Ippolita Sforza, though she died before their publication, because it was at her desire that the work was originally undertaken. Besides this general dedication, each novel is addressed to some *Valoroso Signore*, or *Chiarissima Signora*, and in these introductions, the novelist generally explains how he came to a knowledge of the event he is about to relate. He usually declares that he heard it told in company,—details the conversation by

Bandello. which it was introduced,—and pretends to report it, as far as his memory serves, in the exact words of his authority.

Bandello is chiefly indebted for his celebrity to these Novels, which belong to a class of composition that enjoyed for many centuries the utmost popularity in Italy. The tales of the French Trouveurs, having passed into Italy towards the close of the thirteenth century, were first imitated in the *Cento Novelle Antiche*; which also contains stories formed from episodes in the romances of chivalry, the ancient chronicles of Italy, and jests or repartees current by oral tradition. Boccaccio, whose *Decameron* appeared shortly after, identified this species of composition with the history of Italian literature, and the progress of the Italian language. That celebrated writer was followed by Sacchetti, Ser Giovanni, Cenchio, and a numerous tribe of imitators, of whom Bandello is by much the best known, and most celebrated, at least in this country. His popularity, however, has not been so great in Italy, which may probably be attributed to the negligence and impurity of his style; a defect of which the author himself appears to have been conscious, as he repeatedly apologizes for his defects in elegance of diction. *Io non son Toscano, nè bene intendo la proprietà di quella lingua; anzi mi confesso Lombardo.* Napioni, in his eulogy of Bandello, confesses that he is not remarkable for that harmony of periods, and delightful naïveté of expression, for which Boccaccio and others of his predecessors were so distinguished; but he adds, that none of the Italian novelists are so interesting for the development and illustration of minute historical facts, which would in vain be sought for in the histories of the revolutions of the Italian States. Some of the novels of Bandello, however, it must be admitted, are little edifying; and it is curious, that one of his stories, which is perhaps the most obscene in the whole series of Italian novels, should be declared, in the introduction, to have been related by the celebrated Navagero, to the Princess of Mantua and Duchess of Urbino. Besides, notwithstanding the repeated assertions of Bandello, that all his stories have some foundation in fact, and the light which his eulogists suppose that they throw on the history of the Italian Republics, it cannot be denied, that the greater proportion of them are derived from the Fableux of the French Trouveurs, and the works of preceding Italian novelists, with an alteration of the names, and some slight variations in the incidents. But while Bandello has thus copied largely from preceding fablers, none of their works have suggested more to others, or are more curious for illustrating the genealogy of fiction, and the transmission of fabulous incident, from the novelist to the dramatic poet. Many of the tales of Bandello were translated by Belleforest in his *Histoires Tragiques*, whence they found their way into Prynne's *Palace of Pleasure*, and other works of a similar description which appeared in England, during the reign of Queen Elizabeth. In this manner they furnished the plots of many tragedies and comedies, to the most numerous and noble race of the English dramatic poets. That part of Shakespeare's *Much Ado about Nothing*,

VOL. II. PART I.

which relates to Don John, Claudio, and Hero, is taken, with little variation in the incidents, from the twenty-second tale of the first part of Bandello; and *Twelfth Night* is borrowed from the thirty-sixth of the second part. Massinger has been indebted for his *Picture*, which is, perhaps, the most agreeable and fanciful of his dramas, to the twenty-first of the first part; while Beaumont and Fletcher have derived from the same source their comedy of the *Maid in the Mill*, and the *Triumph of Death*, which is the third of their "Four Plays in One." The thirty-fifth of the second part of Bandello is the same story as the plot of Horace Walpole's *Mysterious Mother*, and the thirtieth tale of the Queen of Navarre. As the works of Bandello and the Queen of Navarre were printed nearly at the same period, it is not probable that they copied from each other, and it may be presumed, that some current tradition furnished both with the horrible incident they report. Mr Walpole, however, disclaims having had any knowledge of the tale of the Queen of Navarre, or Bandello, at the time he wrote this drama. Its plot, he says, was suggested by a story he heard when very young, of a lady, who, under uncommon agonies of mind, had waited on Archbishop Tillotson, and besought his counsel in what manner she should act under the fatal circumstances that had occurred.

Besides his *Tales*, Bandello is author of a poem in eleven cantos, which was his first work, and is now very scarce, entitled, *Delle Lodi, della Signora Lucrezia Gonzaga*, printed at Agen, 1545, in 8vo. He also wrote a complimentary poem, in three cantos, on the birth of a son of his patron, Cesar Fregoso. Both these productions are written without taste or spirit; but it is said, that some good verses, composed by Bandello, on different subjects, are still preserved in manuscript in the library of the Academy of Turin.

(M.)
BANDINI (ANGELO MARIA), a learned Italian, was born at Florence on the 25th September 1726. Having been left an orphan in his infancy, he was supported by his uncle, Joseph Bandini, a lawyer of some note. He was educated among the Jesuits, and discovered an early passion for the study of antiquities. A desire which he also manifested to distinguish himself as a poet, was fortunately checked by the ill success of his first attempt; and, from that period, he devoted himself principally to literary history and archæological science. The celebrated Dr Lami, with whom he had the good fortune to contract a friendship, assisted him with his counsels, and encouraged him to persevere in that path, to which his genius seems to have directed him.

In the year 1747, Bandini undertook a journey to Vienna, in company with the Bishop of Volterra, to whom he acted in the capacity of secretary. He was introduced to the Emperor, and took the opportunity of dedicating to that monarch his *Specimen Litteraturæ Florentinæ*, which was then printing at Florence. The following year he returned by the way of Venice, Padua, Ferrara, and Bologna, and united himself in friendship with the learned men in all these cities. Having resided sometime at Florence, he repaired to Rome, and entered into orders,

K

Bandello
Bandini.

Bandini.

passing the whole of his time in the library of the Vatican and in those of the Cardinals Passionei and Corsini. At that time, the famous obelisk of Augustus was dug out of the ruins of the *Campus Martius*. Bandini, by the order of Benedict XIV., undertook to describe and explain this curious monument; but finding that the air of Rome was injurious to his health, he returned to Florence. In 1750, he was selected by Alexander Marucelli to take charge of the valuable library, which his uncle, the Abbé Francis Marucelli, had left, and which, according to the will of the founder, was to be open to the public. But he had scarcely entered upon the duties of this charge when the proprietor died, after bequeathing all his effects to the library, and appointing the Abbé Bandini perpetual librarian and his testamentary executor. It required two years to liquidate the succession, and to form the complete catalogue of this vast library, which was at length opened to the public in the year 1752. In 1756, he was preferred by the Emperor to a prebend at Florence, and appointed principal librarian to the Laurentian library. During forty-four years he continued to discharge the duties of this situation, and died in 1800, generally esteemed and regretted. On his deathbed he founded a public school, and bequeathed the remainder of his fortune to other charitable purposes.

The first work by which Bandini became known as a man of letters was his *Dissertatio de veterum Saltationibus*, which he wrote at the age of twenty-two, and which was inserted by his learned friend Lami in the fifth volume of the works of Meursius, published in 1745. The most remarkable of his other works are, 1. *Specimen litteraturæ Florentinæ seculi XV. &c.* 2 vols. 8vo. 2. *De Obelisco Augusti Cesaris, e Campi Martii nuderibus nuper eruto*, 1750, fol. 3. *Collectio veterum aliquot Monumentorum ad historiam, præcipue litterariam pertinentium*. 1752, 8vo. 4. *Elogio dell' ab. Francisco Marucelli fondatore della pubblica libreria Marucelliana*. 1754, 4to. 5. *Vita e lettere di Amerigo Vespucci*. 1745, 4to. 6. *De vita et scriptis Joan. Bapt. Donii Patricii Florentini, libri V. adnotationibus illustrati; accedit ejusdem Donii litterarum commecium nunc primum in lucem editum*. 1755, fol. 7. *Vita di Filippo Strozzi*. 1756, 4to. 8. *Vita del cardin. Niccolò da Prato*. Eod. an. 4to. 9. From 1763 to 1766, he employed himself in publishing successively the works of some of the minor Greek poets, which he enriched with notes and various readings. These were Callimachus; the two poems of Nicander on poisons and antidotes; the *Phenomena* of Aratus; the poems of Musæus; those of Colluthus on the rape of Helen, and Tryphiodorus on the taking of Troy; Theognis, Phocylides, and the golden verses of Pythagoras. The Greek text of these poems was carefully collated with the best manuscripts; and there were added translations, in Italian verse, by Ant. Mar. Salvini. 10. *Catalogus codicum manuscriptorum Græcorum, Latinorum, et Italicorum, bibliothecæ Laurentianæ*. 1764-78, 8 vols. fol. 11. *Bibliotheca Leopoldina Laurentiana, sive Catalogus Manuscriptorum, qui jussu Petri Leopoldi in Laurentiana translati sunt*. 1791-93, 3 vols. fol. 12. *De Florentini Juntarum Typographia, ejus qui censoribus*.

1791, 2 parts, 8vo. See *Biographie Universelle*, **Banffshire**. Tom. III. (H.)

BANFFSHIRE, a county in the north of Scot-Situation land, having the Murray Firth on the north, Aber- and Extent. deenshire on the east and south, and the county of Moray on the west, is situate in the 58th degree of north latitude, and contains 647 square miles, or, without including a small space covered by water, 412,800 English acres. Along the coast, for about Surface. 30 miles, the soil consists chiefly of sand and loam, and is in many instances well cultivated; but, with the exception of this tract, Banffshire is a hilly, and, towards the south, a mountainous district, though many fertile valleys are interspersed; and there is much valuable grazing land, well sheltered with natural wood, on the banks of its streams, and in its romantic glens. The Spey, one of the most consi- Rivers. derable rivers in Scotland, which flows on its western boundary, and the Deveron on its eastern, to both of which a number of rivulets are tributary, yield a considerable revenue from their salmon-fishings,—the former, according to the agricultural survey in 1812, upwards of L. 6000, and the latter about L. 2000 yearly. In the lower part of the country, towards Seats. the coast, there are several magnificent buildings, of which Duff House, the principal seat of the family of Fife, Cullen House, the seat of the Earl of Findlater and Seafield, and Gordon Castle, the most princely mansion in the north of Scotland, are the most conspicuous. Around these, and a great number of gentlemen's seats in the interior, the plantations are extensive and ornamental; but the extent and the value of the natural woods is inconsiderable. Plantation.

Calcareous substances in the form of marble, limestone, and marl, abound, yet, owing to the want of coals, the greater part of the lime used on the lands near the coast is brought from Sunderland. The other minerals most worthy of notice are freestone, granite, slate, brick-clay, to which must be added the rock-crystals and topazes, found on the mountain of Cairngorum, and other parts of that elevated range which forms the southern and western boundaries of Banffshire. In summer 1811, L. 2000 worth of these stones were found; and in some instances to the value of L. 200 in one day. *Cudbear* or *cup-moss*, though certainly a vegetable substance, may be mentioned along with minerals, from its growing only in rocky mountainous situations. Its use in dyeing purple, after undergoing a simple preparation, is said to have been discovered by Mr Gordon, a gentleman of the parish of Kirkmichael in this county, before the year 1755. In 1808 and 1809 about L. 500 worth of it, gathered on the mountains of Banffshire, and those adjoining in Aberdeenshire, was purchased for the manufactures of Glasgow. Minerals. Cudbear.

Neither the climate nor the soil of this county, Agriculture. except along the coast, is favourable to extensive aration; the subsoil of the higher grounds being in general retentive of moisture, and grain very late in ripening. Only about a fourth part of its contents is considered to be at all fit for tillage. Almost all the crops usually cultivated in Scotland have, however, gained a firm footing here, though oats occupy by far the greatest proportion of the arable surface. In this, as in the other northern counties, the chief

Banffshire. dependence of the husbandman is on his live stock ; and there being comparatively few sheep, the tenantry look to their cattle as the great fund for paying rents and all other charges.

Farms are generally so small as scarcely to deserve the name, most of the land being parcelled out into holdings of less than 30 acres ; and the management is but too often incorrect and unproductive. For what improvements have been made in its agriculture, this district is much indebted to one of the Earls of Findlater, who, so early as 1754, not only introduced and exhibited on some of his own farms the most approved practices then known in England, but held out liberal encouragement to his tenants to follow his example. The valued rent is L. 79,200 Scots ; and in 1811, according to the assessment to the Property Tax, the real gross rent of the lands was L. 79,396, 3s. 4d., and of the houses L. 5514, 2s. Sterling. The valuation of estates held under entail is more than a half of the whole.

Valued and Real Rent.

Auchenhalrig Work.

The mud buildings, common in some of the northern counties, called *Auchenhalrig work*, from a place of that name in Banffshire, have been found a cheap, and by no means a bad substitute for stone and lime walls in farm offices. About 30 carts of stones, round, or rather small, 10 carts of clay or mud, to which a certain proportion of sand is added, and 24 stone of straw, make a rood of 36 square yards. Several houses built of these materials have stood upwards of a hundred years.

Manufactures.

There is scarcely any thing deserving the name of manufactures in this county. The linen, and more

lately the cotton branches, employed a number of hands, but both have declined of late. Coarse woollen stuffs are made in private families for home consumption ; and tan-works, breweries, rope-works, &c. have been established on a small scale. Its commerce by sea is equally inconsiderable. At the ports of Banff, Macduff, Portsoy, and Gardenstown, a few vessels carry on a little trade, chiefly coastwise, importing coals, iron, timber, and other necessary articles ; and exporting salmon and other fish, butter, and a little grain. But the cattle driven to the southern markets make the principal returns. The salmon-fishings have been already noticed, and there are 10 fishing villages, which, besides yawls, employ from 50 to 60 boats in the white fishery. Herrings have lately appeared on this coast.

Fishing Vil-lages.

Several remains of antiquity are pointed out in different parts of Banffshire, of which the churches of Mortlach in the mountains, and Gamray on the shore, are perhaps the most remarkable ; exhibiting the savage triumphs of our ancestors over the invading Danes 700 years ago, in their sculls built into the solid walls. Ruins of castles and traces of encampments are frequent ; but scarcely any of those circles of stone are to be seen, which are supposed to belong to a much more remote age.

Antiquities.

The population, as taken under the acts 1800 and 1811, is given in the table below ; but it appears that, in some instances, the population of parishes, part of which lie in other counties, is included in the returns for these counties.

Population.

1800.

HOUSES.			OCCUPATIONS.			PERSONS.		
Inhabited.	By how many Families occupied.	Uninhabited.	Persons chiefly employed in Agriculture.	Persons chiefly employed in Trade, Manufactures, or Handicraft.	All other Persons not comprised in the two preceding classes.	Male.	Females.	Total of Persons.
7789	8677	166	11,177	4890	18,288	16,067	19,740	35,807

1811.

HOUSES.				OCCUPATIONS.			PERSONS.		
Inhabited.	By how many Families occupied.	Building.	Uninhabited.	Families chiefly employed in Agriculture.	Families chiefly employed in Trade, Manufactures, or Handicraft.	All other Families not comprised in the two preceding classes.	Males.	Females.	Total of Persons.
8043	8612	63	223	3815	2195	2602	16,465	20,203	36,668

(A.)

BANKING.

IN the *Encyclopædia* will be found some explanation of the nature and origin of banking; and it now remains to describe the improvements which have been subsequently introduced into this important art of money-dealing, and to give some account also of the principal banks, which, in the progress of commerce and of wealth, have been established in this, and in other countries.

Purpose for which Banks were originally established.

The chief purpose of the different banks which were established throughout Europe during the fifteenth and sixteenth centuries, such as the banks of Venice, Genoa, Amsterdam, Hamburgh, and Nuremberg, was to provide, for the convenience of commerce, a currency of a determinate and invariable standard. Before this period, the currency of those places was lost amid an inundation of the light and debased coins of every adjacent state; and the business of commercial exchange was in this manner obstructed by the want of some certain measure of value. By the establishment of banks of deposit, as they are generally called, which paid all demands on them in money of a known weight and fineness; and by ordaining, at the same time, that all payments above a certain sum should be made in bank money, the greatest possible degree of certainty was given to the value of the currency, while, by adopting the method of paying large sums, by means of a simple transfer from one name to another in the books of the bank, great facility and dispatch were obviously given to all cash transactions. Nor were those advantages confined to the particular places in which banks were established. It was soon found, that the same improvement which was so useful in the domestic transactions of a community could be employed with even greater advantages, in simplifying the cash transactions of distant places. The inconveniences to which merchants residing in the same place must have been exposed in making payments to each other, previous to the establishment of banks, would necessarily consist in the want of some fixed and invariable measure of value; in the counting, weighing, and useless transportation of large sums from one hand to another; and in the frauds and mistakes which would frequently occur in these cumbersome transactions. But in the commercial intercourse of distant places, all those disadvantages would be greatly aggravated; there would be more scope for frauds and mistakes; they would be less easily corrected; and, without some system of money-dealing, the commerce of distant places must be limited to mere barter, or to the instant exchange of specie for goods. The progress of wealth and industry is, however, necessarily accompanied by the growth of confidence and credit. Upon this new principle, commercial dealing is gradually extended; and in these circumstances, without the intervention of the money-dealer, there must be a continual and useless transportation of specie between all commercial towns. No debt can be discharged without a remittance in cash, and each separate transaction

will require a separate remittance. To obviate these useless payments in detail, the business is naturally transferred to a separate class of dealers, by whom the whole debts and credits of the community, in place of being settled individually, are brought to a general balance, and it is only for the discharge of this balance, that it is necessary to remit specie. The arrangements by which this result is produced are exceedingly simple and obvious, and are now become so familiar, that they hardly require to be explained in detail.

Utility of Banks.

When, in the progress of wealth and improvement, certain individuals begin to acquire, from their increased wealth and their extended trade, the general confidence of the community, it will naturally occur to inferior traders, who have remittances to make to other places, that the great merchant, by means of his credit and connections, may assist him in his transactions with those distant parts. If the one has money to remit, the other may have money to receive, and in this manner, by means of credit and confidence, the engagements of the different parties may be duly discharged by a mere transfer of debt from one person to another. Thus, we may suppose A, the great merchant, has money to receive from the same place to which B, the inferior merchant, has money to remit. He receives the money from B, giving him, of course, an order on the debtor which he has in the same place in which B's creditor resides. To this place the order being sent, the debt belonging to A is transferred to the creditor of B. And thus, by the mutual transfer of claims, without the intervention of specie, this account of debt and credit is finally settled. The credit and connections of the wealthy merchant, inducing others to deposit money with him for the purpose of being remitted to their respective creditors, the cash transactions of the town and neighbourhood gradually centre in his hands. All those who have money to remit, or money to receive, entrust the transaction to his management; he receives their money, for which he gives them his drafts, or their bills, for which he either gives them money, or undertakes to procure payment, and, in this manner, the debts and credits of the different commercial towns, in place of being settled as formerly in detail, are, by the agency of the money-dealers, brought into one general account, and reduced at once to a common balance. The establishment of such public banks as those of Venice, Genoa, Amsterdam, Hamburgh, &c., on the solid security of large deposits of treasure, by inspiring general confidence, would tend to give life and activity to this improved system of money-dealing. The credit of an individual, however respectable for wealth, integrity, and prudence, could hardly be supposed in any case to be equal to that of those public establishments which were the general depositories of all the floating capital of the community, of which the management was committed to directors publicly chosen, and bound down in their

Banking. conduct to certain general rules, from which they have no discretionary power to depart. In the two great sources of mercantile confidence, therefore, namely, the reputation of wealth and prudent management, those institutions could not be exceeded. They were evidently beyond the reach of all the ordinary casualties of commerce, and it could only be by foreign invasion, or by some great internal convulsion, which would tend to the dissolution of all civil order, that their ruin could be accomplished. Their bills and drafts possessing a proportionably extensive circulation, formed a species of currency in universal credit, throughout the great mercantile community of Europe, and furnished a most convenient instrument for settling, in the most easy and expeditious manner, the cash transactions between distant parts.

It has been suggested, that those bills of exchange and drafts were the invention of the Jews, and such may very possibly have been the case. But the just and philosophical remark of Mr Dugald Stewart, in regard to the invention of printing, may be generally applied to the progress of mankind in all other arts and sciences. On this subject, he observes, that to whomsoever the credit of this important discovery may be due, it is evident, from the state of society at that time in Europe, and from the rapid progress of all moral improvement, that some such process, for the speedy dissemination of knowledge, must have been discovered about this period. The general condition of the world, created, if we may so express ourselves, an effectual demand for the discovery; and the ingenuity of mankind being turned to this object, the necessary means for gratifying the love of knowledge and inquiry, now fairly awakened, were speedily devised. In like manner, it may be remarked of bills of exchange, that the gradual progress of mankind in wealth and improvement, favoured the growth of mercantile confidence, which was still farther strengthened by the establishment of public banks of undoubted credit; and that, by whomsoever bills of exchange were first used, some such invention was the necessary result of that increased confidence and credit, which the progress of wealth and industry was rapidly diffusing over all Europe.

In general, the public banks established throughout Europe were found to answer all the purposes of their institution. As their credit was beyond all question, they afforded a solid foundation for commercial confidence, and their affairs being managed with prudence, they increased in respectability and credit, supplying the home merchant with a safe and convenient instrument of exchange, and enabling the foreign merchant to receive remittances from abroad, or to make his payments more cheaply, safely, and expeditiously than before. In addition to those already mentioned, other banks were established in different parts of Europe, and upon the same model. But, in some cases, owing to a deviation from their original rules, and to an imprudent extension of their concerns, from a desire of inordinate gains, they were occasionally in want of specie, and being unable to pay on demand, they fell from that high degree of credit, which is essential to the usefulness and prosperity of such institutions.

Banking. By the general circulation of the bills of those public banks, the use of specie was in a great measure superseded as a medium of exchange between distant parts; and it was obvious, that, by following out the same principle in the domestic circulation of a country, paper might, in like manner, be substituted for specie in its internal commerce. When a debt against persons of undoubted ability to pay is once constituted by a written document, the debt may, by means of this document, be made over to liquidate the claims of a third party, and in this way, a cumbersome species of paper currency may be employed in the great transactions of trade. By improving the form of this instrument, however, by circulating bills for small sums, and by making them payable on demand, a public bank, in good credit, will supply the community with a paper currency so convenient as to answer all the purposes of specie.

In the course of the last century, public banks for the circulation of paper in lieu of specie have been established in most of the great cities of Europe. Of these, the most important, whether we consider its great wealth, or the vast extent of its transactions, is the Bank of England. Of the nature and origin of this establishment, an account will be found in the *Encyclopædia*; and, in this supplementary work, we shall proceed, briefly, to notice some of its more recent transactions, and also to describe generally the effects produced by so powerful an engine on the circulation and commerce of the country.

The Bank of England, when it was first incorporated, assisted Government with a loan of L. 1,200,000, and it has subsequently been in the practice of accommodating the public, from time to time, with loans to a considerable amount. In 1746, those advances, which form its undivided capital, amounted to L. 11,686,800, for which interest is paid by Government at the rate of 3 per cent.; and its divided capital had been, at the same time, raised, by different calls and subscriptions, to L. 10,780,000. The state of these two sums continued nearly the same till the year 1800, when the Bank, in consideration of the renewal for twenty-one years of its charter, which expired in 1812, advanced to Government a farther sum of L. 3,000,000, without interest, for six years. This sum became payable in the year 1806, at which period, it was agreed, after some discussion, that the loan should be continued to Government during the war at an interest of 3 per cent. In the following year, in consequence of the great profits arising from the vast and increasing amount of the public money deposited in the Bank, the Chancellor of the Exchequer claimed for the public some compensation, either by an annual payment of money, or by a loan without interest. In the year 1797, the deposits of cash in the Bank, whether belonging to the public or to individuals, amounted altogether to L. 5,130,140. The Government balances alone had increased, in the year 1807, to the enormous amount of between L. 11,000,000 and L. 12,000,000; and, in consideration of the profit accruing to the Bank from the use of this money, its directors agreed to lend L. 3,000,000 to Government without interest, until six months after the conclusion of a definitive treaty of peace. This loan, together with the former loan of

Establishment of the Bank of England.

Transactions with the Government.

Banking. L. 3,000,000 granted in 1806, became due in the year 1814. The loan of 1806 was discharged, but the loan with which Government was accommodated in 1808 was continued to the public till 5th April 1816. According to an arrangement made at this time, the Bank was allowed to add to its capital L. 2,910,600; and in return the loan of L. 3,000,000 was continued at an interest of 3 per cent. An ad-

ditional advance was also made to Government of **Banking.** L. 6,000,000, at an interest of 4 per cent. The debt of the Government to the Bank has been in this manner increased from L. 11,686,800 to L. 20,686,800.

The following view of the state of its circulation *Circulation* at different periods, from 1718 to the present year *of the Bank* (1816), is extracted from accounts laid before Par- *of England.* liament.

Amount of Bank of England Notes in Circulation at the following Periods.

In the Year	Notes of L. 5 and upwards.	Notes under L. 5.	Bank Post Bills.	Total.
1718.	L. 1,829,930			L. 1,829,930
1721.	2,054,780			2,054,780
1730.	4,224,990			4,224,990
1754.	3,836,870		L. 186,920	3,975,870
1761.	5,863,290		138,520	6,001,810
1762.	6,012,150		119,620	6,131,770
1763.	6,716,660		173,020	6,889,680
1772.	5,881,960		319,070	6,201,030
1778.	7,030,680		509,390	7,540,070
1783.	6,354,070		353,470	6,707,540
1784.	6,074,930		317,800	6,392,730
1791.	10,027,600		661,910	10,689,510
1792. Average of Jan. and July	10,277,990		724,865	11,102,855
1793. Average of Jan. and July	11,193,105		735,005	11,928,110
1794. Average of Jan. and July	9,670,450		576,130	10,246,586
1795. Average of Jan. and July	9,580,300		559,605	10,139,905
1796. Average of Jan. and July	9,516,000		590,165	10,106,165
1797. January July	8,742,530 9,331,920	L. 921,780	461,970 524,400	9,204,500 10,778,120
1798.	9,571,945	1,483,740	506,045	11,561,730
1799.	10,135,265	1,526,890	561,385	12,223,540
1800.	11,385,380	1,704,880	723,525	13,813,785
1801.	12,913,460	2,439,650	816,760	16,169,870
1802.	12,541,675	2,939,730	762,710	16,244,115
1803.	10,978,655	3,243,595	748,920	14,971,170
1804.	11,763,035	4,564,415	739,225	17,066,675
1805.	11,319,370	4,509,034	933,970	16,762,374
1806.	11,491,765	4,255,130	685,495	16,432,380
1807.	11,295,215	4,062,770	677,965	16,035,950
1808.	12,264,170	3,987,720	667,385	16,919,275
1809.	12,881,095	4,442,500	782,260	18,105,855
1810.	14,627,680	5,990,695	834,555	19,452,930
1811.	13,522,210	7,209,700	1,049,470	21,781,380
1812.	15,238,425	7,594,605	1,048,680	23,881,710
1813.	14,996,635	7,712,135	977,335	23,686,105
1814.	16,214,830	8,313,380	1,089,340	25,517,550
1815.	16,522,530	9,065,890	1,215,100	26,803,526
1816. April	16,096,950	9,135,000	1,362,410	26,594,360

**Flourishing
State of its
Affairs.**

Notwithstanding the embarrassments to which the Bank of England has been occasionally exposed from the fluctuations of commerce, and from the effects of political alarms, the amount of its capital, and the extent of its transactions, have been gradually increasing, and the wealth which it has now accumulated is

greater, perhaps, than was ever before engrossed by any other trading corporation. Previous to the year 1797, the state of its affairs was not generally known to the public. But at that period its affairs having been submitted, in consequence of the suspension of its cash payments, to the investigation of

Banking. a Parliamentary Committee, it appeared that, besides paying a dividend generally of from 5½ to 7 per cent., it had accumulated a fund of undivided profits amounting to L. 3,800,000. Since the year 1797, its affairs have been even in a more flourishing condition than at any former period. Its circulation has been increased from L. 11,000,000 to L. 27,000,000; its transactions have been extended, and its profits have been augmented in proportion; while the law releasing it from the obligation of paying in specie, by rendering it unnecessary to keep in reserve so large a stock of cash, has tended greatly to increase its command of active and productive capital. It has been already stated that the Bank, besides transacting the ordinary business of discounting mercantile bills, is also employed as a great engine of State,—receiving and paying the interest due to the public creditors,—circulating exchequer bills,—accommodating Government with immediate advances on the credit of distant funds, and assisting generally in all the great operations of finance. In its capacity of public banker to the State, the Bank has an allowance for the management of the national debt; it has an allowance of L. 800 per million on the whole amount of every loan of which it receives the payment; upon every lottery contract, it is allowed L. 1000; and, lastly, it has the use of all the public money committed to its charge, besides several other allowances of less importance. The sum paid for the management of the public debt has varied according to circumstances. In the year 1726, under the economical administration of Sir Robert Walpole, L. 360 per million was paid to the Bank on this account; the allowance was afterwards increased to L. 562, 10s. per million. But, in the year 1786, when the public debt amounted to L. 224,000,000, it was reduced to L. 450 per million, at which rate it continued till the year 1807, when, in consequence of the vast increase of the public debts, it was still farther reduced to L. 340 per million, on the first L. 600,000,000 of debt, and to L. 300 per million on the excess beyond L. 600,000,000; at which rate it still continues.

Business transacted by the Bank for Government.

In the course of the two last wars, the business transacted by the Government at the Bank has increased far beyond its former extent. The debts of the country, on the management of which the Bank receives a commission, have risen from L. 224,000,000 to about L. 830,000,000. In the year 1792, the sum paid to the Bank for the management of the public debt, and for receiving the contributions on loans and lotteries, amounted to L. 99,803; while, for the year ending 5th April 1815, the sum paid for the same service amounted to L. 281,568, being an increase of L. 181,765. During the same period, the public deposits of cash at the Bank, in consequence of the increased pecuniary transactions of

Banking. Government, have been accumulating in a similar proportion. In the year 1792, these deposits could not have amounted to L. 4,000,000. Since that time they have been rapidly increasing; and from the year 1806, the average amount may be stated at between L. 11,000,000 and L. 12,000,000, on which the Bank have been receiving interest at the rate of 5 per cent. As a compensation for the use of this money, the Bank, as has been already stated, lent to Government L. 3,000,000, at an interest of 3 per cent., and afterwards an additional L. 3,000,000 without interest. The gain of the public on these transactions being deducted from the annual interest on L. 11,000,000 of the public money, the profit of the Bank on this branch of its business will be found to have amounted, since the year 1806, to nearly L. 382,000 per annum. From all these different causes, therefore, **Wealth accumulated by the Bank.** from the increased circulation of its notes, and from the vast accumulation of public business, the profits of the Bank appear to have been prodigiously augmented in the course of the late war, so that its average dividend, including the *bonus* from time to time added to it, will be found to amount, from the year 1797, to nearly 10 per cent.; and it is calculated besides, on data which admit of no considerable error, that the sum of undivided profit must, in the meantime, have increased to the enormous amount of L. 13,000,000. * Out of this fund the Bank has advanced to Government, for the year 1816, a loan of L. 6,000,000; and at a court of proprietors, held in May 1816, it was resolved to make an addition to the capital of the Bank of L. 2,910,600, the effect of which is to raise the capital of each proprietor of L. 100 of stock, producing at present L. 10 per annum, to L. 125, and to increase his income proportionally, *i. e.* to L. 12, 10s. per annum. The great **Advantages** profit realized by the Bank since the suspension of **resulting from the use of Paper in place of Specie.** its cash payments, has produced a corresponding rise in the value of its stock. Throughout the year 1797, the average price of Bank stock was about L. 125 per cent. Since this period it has been gradually improving in value, and its market price now amounts to about L. 262 per cent. The original capital of the Bank has thus acquired, since the year 1797, when the act passed releasing it from its obligation of paying in specie, an additional value equal to nearly L. 16,000,000; which, added to the estimated increase in the sum of its undivided profit, amounting, according to Mr Ricardo's calculation, to L. 9,599,359, makes a sum of L. 25,599,359, the actual improved value of the Bank capital during the last nineteen years.

One great inducement to establish a bank for the circulation of paper in place of specie is, that it provides a cheap instrument of exchange in place of a more expensive one, and from the obvious advantage of such an operation, both to the individual and to

* This view of the affairs of the Bank, since the year 1797, is founded on the statements contained in the work of Mr Ricardo. He seems to have made his calculations on grounds sufficiently certain, and his capacity for diligent research leaves little room to question his accuracy. The amount of the surplus capital accumulated by the Bank in 1797, which is the foundation of all the subsequent conclusions, is ascertained from the account of its affairs laid before Parliament, at the time of the suspension of cash payments in 1797. See Ricardo's *Proposals for a Secure and Economical Currency, Appendix, No. V. p. 103.*

Banking. the community, paper, after it is once introduced, is gradually found to limit, and at last entirely to supersede, the use of specie in the circulation of a country. Such has been the progress of paper in the currency of Britain. Specie is now entirely excluded from circulation; all that portion of our currency which formerly consisted of the precious metals has either been exported, or is stored up by the bankers, by whom it is kept in reserve, to answer occasional demands. The establishment of one great bank in the capital of the country would facilitate the introduction into other parts of similar establishments, on a smaller scale. Such a bank is naturally a general reservoir of specie for the whole kingdom. Its transactions are of so much greater an extent than those of any other establishment of the same kind, that all the specie which it could collect at home would be insufficient to supply its wants. When its coffers are exhausted, therefore, they must be replenished from abroad. Bullion must be purchased in the great market of the civilized world, and the supply thus imported is gradually distributed, in the general course of circulation and commerce, among the lesser banks. The wants of those smaller establishments can always be supplied, to any extent, from the store of specie collected in the great bank; for they have only to convert a certain portion of their property into its promissory-notes, in order to procure the supply necessary to replenish their exhausted coffers.

**Country
Banks in
Britain.**

Since the establishment of the Bank of England, banks on a smaller scale have accordingly been begun in almost all the provincial towns of Great Britain. They seem to have increased with great rapidity in the course of that short interval of prosperity and peace which followed the American war. During this period, all the great branches of national industry were extremely flourishing—the capital of the country was daily augmenting—the principle of mercantile confidence, the natural effect of such a state of things, was in full vigour,—and spirited individuals, in every quarter, taking advantage of these favourable circumstances, proceeded to establish banks; and having thus created a currency on the foundation of credit, the precious metals were no longer required to carry on the circulation of the country. According to an estimate made by Mr Thornton,* which is rather moderate than otherwise, the number of country banks in Great Britain amounted, in the year 1797, to 353. In 1799, they had increased to 366, and, in 1800, to 386. About this period, they appear to have increased rapidly, for we find the number of licences granted in 1809, for the issue of promissory-notes in Great Britain, to have amounted to 735. In 1812, they amounted to 878; and, in 1814 and 1815, to about 1000. Of these, there are in London, besides the Bank of England, about 70 private banking-houses, and the remaining 930 are dispersed throughout the kingdom. To the management of these various money-dealers, the whole circulation of the country is committed. Their business consists in settling the cash transactions of

Banking. distant places, and in issuing their notes, for the accommodation of trade, by discounting mercantile bills; and the arrangements which they adopt for this purpose are eminently calculated to promote the dispatch of business, and the economy of cash.

We have already, in part, explained in what manner the establishment of accredited banks tends to simplify the cash transactions of distant parts, and it is obvious that a community abounding in bankers of established character and credit, whose promissory-notes and bills of exchange circulate, to the exclusion of specie, must possess ample means for carrying into effect all the refinements of money-dealing. In Great Britain, accordingly, the general progress of trade and manufactures—the known wealth of banking establishments—the security derived from the long continuance of domestic peace—the high state of commercial confidence—the facilities of communication, joined to other advantages peculiar to such an advanced state of society, have brought the system to perfection. By means of bills of exchange, circulated among the different bankers, remittances are made to the most distant parts with the most perfect security, and at an inconsiderable expence. The respective debts and credits of the great commercial towns, in place of being settled in detail, or by remittances in specie, are, by the agency of the money-dealers, collected into one general account, which is brought to a common balance, and in this way the most extensive transactions may be settled with a comparatively small quantity of specie. If we suppose, for example, one of the two trading towns of Glasgow and Manchester to export, to the other, goods to the amount of L.2,000,000 annually, and to receive a return to the value of L.1,900,000, those transactions being, through the medium of the bankers, brought into one general account, there remains only an undischarged balance of L.100,000. But the tendency of the system being to make the whole complicated transactions of an extensive country centre in one common account, it may not be necessary, even for this balance of L.100,000, to send a remittance of specie, seeing that it may be transferred, by a draft on some third place, to a more general fund of debt and credit, where it may be finally met and liquidated by opposite balances to the same amount. Thus, we may suppose the balance of L.100,000, due from Manchester to Glasgow, to be discharged by a draft on London. In this case, London comes in the place of Glasgow, as the creditor of Manchester, the transaction being substantially to transfer the debt to the general cash account of those two places. But Manchester, in consequence of a favourable balance of trade, may be the creditor of other towns, as well as the debtor; and London being credited with the money to be received, as it was formerly charged with the money to be paid, all these insulated transactions are brought into one general account, on which the balance is struck, and it is only for this last and final balance that cash must be provided. In this highly artificial and curious system, the wealthy and populous towns natu-

* See *Inquiry into the Nature and Effects of the Paper Credit of Great Britain*, p. 154.

Banking. rally draw, as to a common centre, all the cash transactions of the neighbourhood; the insulated balances, arising on the commerce of the surrounding country, are formed into new accounts by the money-dealers of these towns, who, by a simple transfer of debt and credit in their books, bring them to a general balance. This balance they afterwards carry to a still more general account; and thus, at length, all the scattered debts of the country are collected into one common account by the bankers of the metropolis, which is then brought to a final balance. The metropolis, the centre of intercourse and trade, is the centre, also, of this vast system of money-dealing. Here, as to a point, all the cash transactions of the country naturally converge, and here the account is finally closed by payments in cash.

In this manner, all the money-dealing of this country, which cannot be transacted without remitting specie, is transferred to London. The payments of London, originating in its own extended commerce, and in its great wealth and population, are of themselves immense. These are still further increased by the payment of the interest on the national debt, which is issued every quarter from the Bank of England; and London having also, in the course of the late wars, grown up to be in some degree the commercial metropolis, both of America and of Europe, it has been found convenient to transfer the payment of foreign bills to it from all parts. In consequence of these extended transactions, London has its debtors and creditors in every quarter of the kingdom. It is the general centre of all money-dealing, and there being, on this account, a greater demand in the country for money in London, than there is in London for money in the country, bills on London are invariably sold in the money market of the country for a premium. The currency of every other bank is limited in its circulation within particular districts, and cannot, therefore, be employed in transacting the payments of distant places. But money in London is a commodity in universal request, and bills for its payment constitute a medium of exchange common to the whole country.

All the various money-dealers who are dispersed throughout the kingdom, require to be provided with a stock of this common currency in order to carry on their business, and, for this purpose, they find it necessary to establish a credit on the metropolis, on which, for a suitable premium, drafts may be obtained from them at all times. By thus transferring the payments of the country, to be settled in one general account in the metropolis, both the expence and trouble of making remittances between distant places has been greatly diminished. It would be interesting if we could collect any exact account of the progressive diminution which took place, in consequence of this improved system of banking, in the expence of managing the cash transactions of the country. But unfortunately those instructive facts which illustrate the progress and internal structure of society, though of far more real importance than the accounts of wars and battles, seldom attract the same attention. On this account, all traces of them are frequently lost before their importance is discovered, and the future inquirer finds himself reduced either to glean from

VOL. II. PART I.

Banking. oral tradition, or from the passing and imperfect records of the day, the scanty materials of domestic history. From some inquiries on this subject, made by a Committee of the House of Commons in 1780, we find, according to the evidence of several of the collectors, that, before this period, the mode of remitting the public revenue to the treasury was both irregular, cumbersome, and expensive. In Scotland there was no certain or regular channel of remitting to the metropolis, and the remittances were not only very uncertain as to the time, but the collectors, not being always able to procure bills, were frequently under the necessity of remitting to the Receiver-General the actual money which they had collected. In different parts of England the same difficulties had, at a former period, been experienced in the remitting of the public revenue. From about the year 1740, it appears, that a premium had been paid to those who undertook the charge of remitting the money, of from 20s. to 2s. 6d. *per cent.* This premium, as the country advanced in wealth and industry, was gradually diminished, and about the year 1778, it was entirely done away, the dates of the bills drawn on London being also at the same time shortened. In 1764, the collector of the Wales district paid 7s. *per cent.* for bills on London, and in 1774, a premium of 2s. 6d. *per cent.* was paid by the collector of Dorsetshire, for bills payable on London at 40 days date. Even so late as the year 1780, though the collectors found no difficulty in the remitting of the public revenue, it was chiefly from merchants and manufacturers that they procured bills on the metropolis. Only a small part of their remittances were made through the medium of the country banks, and in all cases security was required for the whole sum remitted. Since the general establishment of banks, and the consequent increase of commercial confidence, the largest sums are now remitted from the remotest parts with the most perfect regularity, and without either premium or security; the only advantage derived by the banker from the transaction, being the use of the money for a certain number of days, varying in proportion to the distance from London.

All those complicated payments of the country, Mode of which are transferred to London, are finally settled ^{settling the} by the London bankers, with specie or with notes of ^{daily Trans-} the Bank of England, it being the practice to use ^{actions of} the Banks ^{the Banks} no other currency in the payments of the metropolis; ^{in London.} and in managing those extensive money-dealings, they still act upon the principle of collecting the insulated transactions of individuals into one common account, and this account is brought to a general balance. For this purpose a clerk, it appears, is dispatched from each banker, at an appointed hour in the afternoon, and a meeting of the whole having taken place in a room provided for the purpose, each clerk exchanges the drafts on other bankers, received at his own house, for the drafts on his own house, received at the houses of other bankers. The balances of the several bankers being then transferred from one to another, in a manner which it is unnecessary to explain in detail, the several accounts are finally wound up by each clerk into one balance, and it is only for this single balance that each banker has to provide specie

L

Banking. or notes. By this contrivance, so great a saving of cash is effected, that though the daily transactions of those bankers are calculated to amount to nearly L. 5,000,000, about L. 220,000 of bank-notes is generally found sufficient for the discharge of the several balances due at the settlement of the account. Other devices are also put in practice by these active and ingenious money-dealers, for economising the use of cash. Many bankers are allowed to have a general cash-account with the Bank of England, in which, if they are careful to keep a supply of good bills, they may always procure whatever cash they require on a day's notice. For the same purpose also of preventing any waste of the circulating medium, accredited brokers are in the habit of hourly walking Lombard Street, and of borrowing the superfluous cash of one broker and lending it to another, for a day, a week, or any longer period, to be repaid when called for; and so nicely is the scale adjusted by those various devices, that the most opulent houses are frequently accommodated with a supply of cash before three o'clock, to be repaid by a draft at the general balance of accounts, which takes place in the afternoon.*

The recent policy of the Bank of England has also tended greatly to favour those economical contrivances of the inferior bankers. The daily demand made upon them by the Bank for the amount of bills accepted and payable at their several houses, is of course considerable, and was formerly made at an early hour, before the notes were issued for bills discounted on the same day, and without any previous notice to the bankers of the demands for which they might be liable, and of which they had no means of judging. For some time past the Bank has adopted a different practice, having notified the amount of the demand at an earlier hour, and taken payment at four in the afternoon, receiving for part of the sum such drafts or bills as the bankers may happen to hold in place of bank-notes.

In consequence of all those contrivances, the circulation of London is carried on with the smallest possible quantity of currency which is consistent with the regularity of its payments; and any sudden reduction, therefore, in the amount of its circulating cash, would ultimately lead to a state of general insolvency and suspension of confidence. Bills and drafts from all quarters of the country being also made payable in London, and accepted by the different bankers, and a failure in any one of those payments being deemed an act of insolvency, it is evident that any general derangement of credit in London must spread far and wide throughout the kingdom. The punctuality of the London payments is necessary to sustain and regulate the whole paper credit of the country; and these payments being made exclusively in Bank of England notes, the circulation of those notes cannot, in any case, be materially reduced with safety to the community. Prior to the restriction act, there was no risk of any un-

Banking. due increase in the circulation of bank-notes, as the excess would have been immediately returned in exchange for specie. But the Bank, being now released from its obligation to pay in specie, and being thus closed against any return of its superfluous notes, its circulation may be increased at the discretion of its directors; and, in these very peculiar circumstances, it is the opinion of Mr Thornton, † that the true policy of the Bank is generally to allow its circulation to vibrate within certain limits; to resort, when the temptation to borrow in the way of discounts is too strong, to some effectual principle of restriction, but in no case materially to reduce the sum in circulation; to afford a slow and cautious extension of it, as the general trade of the kingdom is enlarged; and to allow of a temporary increase, even beyond its usual limits, in a season of extraordinary difficulty or alarm.

It is justly observed by Dr Smith, after he has explained all the advantages of banking, that the commerce and industry of a country cannot be so secure when managed with paper money, as when managed with a currency of gold and silver. "The gold and silver money which circulates in any country," he observes, "may very properly be compared to a highway, which, while it circulates and carries to market all the grass and corn of the country, produces itself not a single pile of either. The judicious operations of banking, by providing, if I may be allowed so violent a metaphor, a sort of waggon-way through the air, enable the country to convert, as it were, a great part of its highways into good pastures and corn-fields, and thereby to increase very considerably the annual produce of its land and labour. The commerce and industry of the country, however, it must be acknowledged, though they may be somewhat augmented, cannot be altogether so secure, when they are thus, as it were, suspended on the Dædalian wings of paper money, as when they travel about upon the solid ground of gold and silver. Over and above the accidents to which they are exposed from the unskillfulness of the conductors of this paper money, they are liable to several others, from which no prudence or skill of these conductors can guard them." (*Wealth of Nations*. Buchanan's edit. Vol. I. p. 508.)

The necessary effect of every system of paper currency is, to encourage the principle of commercial credit. This is, indeed, the foundation on which it is raised, and the more widely the circulation of paper is extended, the more closely will the mercantile community be knit together by the artificial ties of confidence and credit. Wherever there is trade, there must no doubt be credit. But where banks are generally established for the purpose of circulating paper money, credit must be augmented tenfold, seeing that, in such circumstances, no one can receive a payment without becoming a creditor. It is an evil, therefore, inseparable from any system under which a currency of the precious metals is superseded.

Disadvantages incident to a Currency of Paper.

* *Bonsanquet's Observations on the Report of the Bullion Committee.*

† *Inquiry into the Nature and Effects of the Paper Credit of Great Britain*, p. 295.

Banking. ed by one purely conventional, that while a useless expence is thereby saved to the community, and while its capital also acquires an increased degree of activity, the trading part of society are brought into such a state of general dependence, that every man may be said, in some degree, to rest upon his neighbour, and the whole to rest upon the principle of confidence in each other. The banker's notes obtain a general circulation; no demand is made upon him for their payment in cash, because the public believe that he has property to pay them. The banker, in like manner, discounts the merchant's bills, from an opinion of his solvency, and the merchant, in giving credit, is guided by the same rule. Confidence, in short, is the charm which holds the whole together, and while this principle prevails, no evil will result from this complicated system of credit. Bank-notes will circulate freely—there will be no great demand for specie—and the merchant will always be enabled to convert his bills into cash. In these circumstances, every expedient will be adopted to spare the use both of notes and of specie. The merchant will naturally be anxious to reduce as low as possible the stock of cash which he reserves for occasional demands; in many cases he will trust to accident for providing funds, such as to the sale of his goods, or to his credit with his banker; while the banker, who provides a cheap instrument of exchange in place of a more expensive one, and whose profit consists in lending it on the same terms, has, in like manner, a strong inducement to increase the circulation of his paper, and, trusting to his credit, to diminish the specie reserved for its payment. While the system is in this manner strained to its utmost pitch, the merchants managing the commerce of the country with the smallest possible quantity of paper, and the bankers circulating the paper with the smallest possible quantity of specie, let us suppose, that from whatever cause, either from the alarms of war, or from a succession of bankruptcies, the principle of mercantile confidence begins to fail. In this case, the former ties by which merchants were connected with each other are now broken; the usual channels of circulation, by which a small quantity of cash rapidly passing from one hand to another, served for transacting the payments of the community, are interrupted, and the money in circulation is, in consequence, found insufficient for the punctuality of mercantile payments. The supply of currency, however, in place of being increased, is still further diminished; the bankers, from the fears natural to their situation, limiting the circulation of their notes, and refusing to accommodate the merchant, as before, by discounting his bills; and the public, in their turn, discrediting the paper of the banks. This general failure of confidence immediately produces alarming bankruptcies, many merchants stopping payments, not from a want of property, but from a want of cash; a run commences on the banks for specie, many of whom are, in consequence, obliged to suspend their cash payments. The Bank of England being the great repository of gold in this country, the demands of the country banks for spe-

Banking. cie gradually centre in the metropolis, the bankers generally disposing of the property which they hold in the public funds and other Government securities, and demanding from the Bank of England specie for whatever quantity of its notes they can collect. The Directors of the Bank, astonished by this alarming drain of their cash, naturally contract the circulation of their paper. But the transactions of the metropolis having been hitherto managed with the most exact frugality, both of notes and specie, this sudden diminution of its circulating cash must leave the money-dealers unprovided with funds necessary for their immense payments, and must thus derange the whole economy of that complicated system which has been raised upon the frail foundations of confidence and credit. The disorder arising in the metropolis, from a want of cash, will soon extend itself to the remotest extremities of the kingdom. In the mutual dependence created by credit and confidence, the failure of one merchant involves others in the same fate, bankruptcies multiply in every quarter, and the alarm increases with such rapidity, as to threaten a general subversion of credit and confidence throughout the country.*

In such a disordered state of the circulation, all the inferior banks are naturally induced, from a prudent regard to their own safety, to limit the issue of their notes, by which means the scarcity of cash is increased, and the evil greatly aggravated. But the Bank of England cannot safely act on such a contracted policy; for it is evident, that the general discredit of bank-notes is occasioned by the alarm prevailing in the country, and that, while this alarm continues, the Bank may be drained of its specie by the most limited circulation of its notes, which will be returned upon it as fast as they are issued. In all such cases, therefore, the only safe course for the Bank to pursue, is rather to enlarge the circulation of its notes, that the alarm may be quieted, and that the supply of currency may be perfectly adequate to effect the daily payments of London, of which the punctual discharge is necessary to the solvency of the country at large. It is not to be wondered at, however, if the Bank, while the nature of paper circulation, and of the evils to which it is exposed, were but imperfectly known, should not always have understood its true interest, and should therefore have hesitated to embrace a policy so unusual, and apparently so hazardous. In the course of the year 1793, the country was agitated by a sudden and general alarm. The scarcity of money was extreme, and paper was discredited. Numerous bankruptcies took place, and there was a great demand among the country banks for specie, which the Bank of England was as usual ultimately called upon to supply. Embarrassed by the drain of its specie, the Directors of the Bank refused to accommodate several great and opulent country banks who applied for assistance, and they were also unwilling to augment the issue of their paper. Immediate and important failures ensued, and the increasing alarm and distress for money in London, plainly showed that the relief of the

* Buchanan's edition of Smith's *Wealth of Nations*, additional volume, p. 99.

Banking. country was necessary to the solvency of the metropolis. It did not appear, that, at this period, the notes issued by the Bank of England were fewer than usual, but, owing to the failure of confidence among mercantile men, they circulated more slowly, and they became in this manner inadequate to transact the immense payments of London, with the same regularity as before.

The Bank of England, not deeming it expedient to enlarge the issue of its paper, a remedy of exactly the same nature was administered by Parliament. A loan of Exchequer bills, to the amount, if required, of L. 5,000,000, was directed to be made to as many merchants, giving proper security, as should apply. Such were the salutary effects of this measure, that the very expectation of a seasonable supply of what could be immediately converted into cash, diffused a general feeling of confidence; the punctuality of the London payments was restored, and the credit of the country began to recover. Of the sum proposed to be granted by Parliament, applications were made for L. 3,855,624, some of which being either rejected or withdrawn, the actual sum issued from the Exchequer amounted to L. 2,202,000, which was punctually repaid without either apparent difficulty or distress. The effect of this measure was to supply the community with a temporary currency, in place of that which had fallen into discredit, or which had been withdrawn from circulation by the caution of the banks; and its advantages were evinced by the speedy restoration of mercantile confidence, and by the increased facility of raising money, which was previously felt both in the metropolis and in the country at large.*

**Interrup-
tion of Cre-
dit in 1797,
and Suspen-
sion of Cash
Payments
by the Bank
of England.**

This state of confidence continued, with little interruption, until the year 1795. At this period, the Bank, in consequence of the large advances which it had made to Government, was under the necessity of retrenching the sum usually allotted for the discount of mercantile bills. A scarcity of cash was soon felt among the merchants and money-dealers of the metropolis, and the threatened invasion of the country, during the year 1796, concurred to spread a general alarm, which naturally gave rise to the discredit of bank-notes, and to a demand for specie. About this period, several banks in the north of England were under the necessity of suspending their cash payments, and the alarm of these failures soon reaching the metropolis, the Bank of England was subjected, about the beginning of the year 1797, to an alarming drain of specie, partly to supply the demand of the country banks, and partly from the return of its own discredited notes. In order to check this increasing pressure, the Bank diminished the circulation of its notes, which having, for several years before, amounted to nearly L. 11,000,000, and having been reduced, for some time, to between L. 9,000,000 and L. 10,000,000, were, at this particular period, brought down to between L. 8,000,000 and L. 9,000,000. From a combination of all these cir-

Banking. cumstances, therefore, namely, the alarm in the country—the discredit of country bank-notes—the pressing demands of those banks for specie, all centering in the metropolis,—and, lastly, the undue restriction of its issues by the Bank, such a scarcity of cash was produced in London, and such an alarm followed, that the run upon the Bank of England for specie, so far from abating, continued to increase with an alarming rapidity. In these circumstances, the Directors communicated to the Chancellor of the Exchequer an account of the precise reduction which had taken place in the amount of their cash, the consequence of which was, that an Order in Council was at length issued, on Sunday the 26th February, restraining the Bank from all further payments in specie. An act of Parliament was soon after passed, confirming the restriction on the cash payments of the Bank; and this principle has been since continued, by successive acts of Parliament. By the last act, passed in April 1816, it is continued for two years from that date.

An event so unlooked-for and unprecedented as a stoppage of payments by the Bank of England, produced, at first, a general feeling of astonishment and alarm; and as the executive government had interfered, on its own discretion, to suspend the obligations of the Bank to its creditors, it was necessary that the sanction of the Legislature should be obtained for this extraordinary exercise of power. The whole matter being therefore referred to the consideration of Parliament, long and anxious discussions took place, on the causes which had given rise to this great convulsion in the mercantile world, and on the policy to be pursued, in a state of things so wholly unexpected. Parliamentary committees were appointed, with power to examine the officers of the Bank, both as to the general state of its affairs, and as to the circumstances which led to its present embarrassments; and by the labour of these committees, joined to the able publications of individuals on the subject, such a precise and accurate account has been collected respecting all the facts of this extraordinary case, that it has not only been made clear in itself, but a new and steady light has been thrown, by the information disclosed, on the general principles of paper currency. We shall briefly consider, on these general principles, to what causes this memorable suspension of cash payments by the Bank of England was chiefly owing.

It is obvious, from the very nature of banking, **Dangers to** that the stock of specie reserved by a bank for the **which** payment of such demands as may be made upon it, **Banks of** cannot bear any proportion to the amount of its **Circulation** notes in circulation; and that, if a certain proportion **are exposed** of these notes should at any time be suddenly returned for payment, a suspension of its cash payments must be the inevitable consequence. This is an evil inherent in the very nature of paper currency, against which no caution can duly provide, since the profit of the banker is exactly in proportion to the

* *Report of the Commissioners to the House of Commons. Thornton On Paper Credit, p. 51. Buchanan's edition of Smith's Wealth of Nations, additional volume, p. 102. Edinburgh Review, Vol. IX. p. 193.*

Banking. excess of his circulating paper over the specie reserved for its payment.

A bank, and more especially a national bank, may be subjected to demands for specie from either of the two following causes: 1st, From an unfavourable balance of trade; or, 2dly, From domestic alarm.

1. When the imports of a nation exceed its exports, a balance of debt will remain due to foreign countries; and in the country which owes the balance there will be a greater demand for money abroad than for money at home. If the unfavourable balance of trade continues, the demand for money abroad, with which the balance may be discharged, will increase, and foreign money, or bills on foreign bankers, will be sold for a premium. In this case, there arises a temptation to export the coin of the country, which, from the state of trade, has become more valuable abroad than at home; and where a national bank is established, whose notes are convertible into cash at the will of the holder, it may undoubtedly be exposed, by an unfavourable balance of trade, to demands for specie to a considerable amount. But, in the nature of things, the drain of specie from this cause must be slow and gradual, and where a bank has ample funds wherewith to purchase specie, it can hardly ever, in this case, be driven to the exceptionable measure of suspending its cash payments. The Bank of England has frequently been exposed, from this or from similar causes, to a regular drain of its specie; but its credit was in no danger from those demands, because its coffers could always be replenished as fast as they were exhausted. Prior to the great recoinage, in 1774, the gold currency of this country was in a very debased state; the market price of gold rose, in consequence, above its mint price; and the value of bank-notes was lowered to the standard of the debased coin, for which they were currently interchanged. In these circumstances, it was a profitable transaction to procure bank-notes for their nominal price in light and worn guineas, and to return them upon the Bank for the same nominal price in guineas of their standard weight, which last were melted down and sold for bank-notes at the market price of bullion; and these notes were immediately returned upon the Bank in exchange for a new supply of standard guineas, to be again melted and sold. In consequence of this state of the currency, the Bank of England was subjected to a constant and regular drain of its specie, and to a very great annual expence in replacing the guineas of which it was drained. But there was no risk that this drain, however expensive and troublesome, would ever lead to a suspension of its cash payments, because it was regular and gradual, and subject to calculation; so that, as long as the Bank had wherewithal to purchase guineas, they could always be provided in sufficient quantity to answer the demand.

In like manner, though a public bank, from an unfavourable balance of trade, or from a great expendi-

Banking. ture abroad, may undoubtedly be exposed to an inconvenient drain of its specie, it seems scarcely possible that this drain can be so rapid as to endanger its credit. It is not in the nature of trade to produce any such sudden and unexpected crisis. The operations of trade always leave time for some previous arrangement, and they have generally some respect also to the convenience of all the parties concerned. It is well known, for example, that in the case of a heavy accumulation of foreign debt, from whatever cause, the balance is more frequently discharged by an exportation of goods than of specie. The effect of foreign debt is to depress the exchange; an unfavourable exchange, or, in other words, the high price of money abroad, operates as an inducement to export goods; the exporter, besides his usual profit, gaining an additional profit equal to the difference of the exchange. It will always be observed, therefore, that a great foreign expenditure is very soon followed by a large exportation of goods, and though specie may be partly remitted for its discharge, the produce of the country is found to answer the purpose equally well. From the year 1793 to 1797, the foreign exportation of this country on the Continent of Europe and to the West Indies, amounted to L. 33,510,779;* and in consequence of these heavy expences abroad, the Bank was subjected to demands for specie to a considerable amount. But though the Directors of the Bank, in their correspondence with the Government, complain heavily of the loss of specie which the Bank had experienced, and though, in February 1796, they even go the length of formally recording it as their opinion, that any farther advance to the Emperor of Germany, or any foreign state, would be fatal to the Bank, † this opinion seems evidently to have been the result of undue apprehension, and to have been expressed strongly for the purpose of deterring the Chancellor of the Exchequer from persevering in his system of lavish advances to foreign powers, the effect of which, they justly conceived, would be injurious to the Bank, by subjecting it to a farther and very inconvenient drain of its specie. But since, in the course of the three several years of 1794, 1795, and 1796, the foreign expenditure of the country amounted to something more than L. 8,000,000, L. 11,000,000, and L. 10,000,000, without injuring the credit of the Bank, it can hardly be believed that an additional expenditure of L. 3,000,000, or even L. 4,000,000, could have given such a sudden shock to its credit, as to have occasioned the suspension of its cash payments. Nor do the Directors, although they express generally their uneasiness at the drain of their specie, ever seem to have contemplated such a catastrophe. On the contrary, the Governor and Deputy-governor, when examined before the Secret Committee of the House of Lords, state that they did not apprehend imminent danger previous to the 21st February 1797. ‡ From all these circumstances, therefore, it appears that the

* *Report of the Lords' Committee of Secrecy, Appendix, p. 107.*

† *Copy of a Resolution of the Court of Directors of the Bank of England, 11th February 1796. See: Report of the Lords' Committee of Secrecy, p. 80.*

‡ *Report of the Lords' Committee of Secrecy, Minutes of Evidence, p. 11.*

Banking. drain of specie to which the Bank was subjected in consequence of the great foreign expenditure of the country previous to the year 1797, or in consequence of any unfavourable balance of trade, though constant, was confined within certain limits; that provision could have been made for it; and that, though it imposed on the Bank a certain annual expence, yet, with due exertion to procure the necessary supplies of specie, it could never have been fatal to the credit of so great an establishment.

2. The drain of specie to which a great national bank may be subjected from the prevalence of a general alarm, is in all respects different from that which may be produced by a great foreign expenditure, or by the fluctuations of trade. The impulse given by panic is, in its very nature, sudden and instantaneous. It generally terminates also, and that speedily, in some violent crisis. If we suppose, therefore, that a bank, which circulates its notes extensively, suddenly falls into discredit, that from some unknown cause, a sudden suspicion of its solvency seizes all the holders of its notes, it is obvious that all these persons, under the violent impulse of their fears, will rush at once to the bank with notes in exchange for specie; and it is equally certain, that whatever funds a bank may ultimately possess, its stock of specie must be speedily exhausted by such a sudden inundation of its discredited notes. In this case its cash payments must be suspended for a time, until the alarm of its creditors be dissipated by a full disclosure of its affairs. Such being the fatal operation of domestic alarm on the credit of a bank, it can scarcely be doubted that this was the immediate cause of the catastrophe which befel the Bank of England in 1797; more especially, as we find that

it was exposed for more than two years to the drain of specie occasioned by foreign expenditure, without any injury to its credit, while one single week or little more of domestic alarm, terminated in a suspension of its cash payments. On Tuesday the 21st February, the Directors of the Bank were so alarmed by the increasing demand for specie, that they communicated to the Chancellor of the Exchequer the precise reduction which had taken place in the amount of their cash. In the course of the preceding week, the drain of guineas had been considerable; but after Tuesday the 21st, it continued increasing with the most alarming rapidity, inasmuch that, according to the evidence of the Directors, the demand for specie, on the two last days of the week, exceeded that of the four preceding days. This is the great and conclusive fact, which points at once to the cause of the ruin which was impending over the Bank. It was not so much the actual loss of specie which excited apprehension, its cash having been lower both during the American war and in the year 1782; but the unparalleled rapidity with which the drain increased, was the alarming circumstance which defied all precautions, and which finally rendered the suspension of cash payments by the Bank an act of overruling necessity. Its stock of specie had no doubt been previously reduced by the demand arising from an unfavourable balance of trade, and this would naturally tend to bring matters more speedily to a crisis. But however well replenished the Bank might have been with specie, the demand was increasing at such an accelerated rate, that, in the course of a few days more, it would have been quite sufficient, without the help of any other cause, to have drained it of its last guinea. *

* That the embarrassments of the Bank were occasioned by the demand at home is plain, from the following evidence of Mr Giles and Mr Raikes, before the Lords' Committee of Secrecy:—

Mr Giles was examined as follows:—

“Has the Bank of England lately experienced an unusual drain of cash?—Most certainly.

“Are you able to ascertain how far this drain was wholly, or in part, occasioned by demands for cash from different parts of the country?—It was owing, in great part, to demands from the country: indirectly from the country, but directly from the bankers in London (who are to supply the country) upon us.

“Whether, by the effects of this drain, the balance of cash remaining in your hands has been reduced considerably below the amount at which it has usually been maintained?—The cash of the Bank has, of late, been considerably reduced. I have known it a great deal lower; but, on this occasion, the demands have been unparalleledly rapid; they have, of late, been progressively increasing, but, in the last week, particularly so; and we had every reason to apprehend that these demands would continue, and even increase.

“Whether such reduction had been continuing in an increased proportion to the balance remaining in your hands up to the date of the minute of Council transmitted to you?—We have generally answered this question in our preceding answer; but, we beg leave to add, that the demands have been progressively increasing in the course of the last week, and in the last two days exceeded the demands of the four preceding days.”

Mr Giles and Mr Raikes were examined as follows:—

“Do you think the restriction made by the order of Council of the 26th of February was necessary?—Certainly.

“Do you consider it as necessary to the interest of the Bank?—The rapid drains we had upon the Bank, and the continuance of them, made us think it advisable to communicate to his Majesty's Ministers the situation of the Bank, that they might, in their wisdom, use such means as they might think expedient.

“When was that communication made to the Chancellor of the Exchequer?—We think the first was on Tuesday the 21st of February; the drains not only continued but increased, and so rapidly the last day or two, that we communicated it to the Chancellor of the Exchequer on Saturday, and had the honour to meet his Majesty's Ministers on the Sunday.

Banking.
Reasons for continuing the Suspension of Cash Payments by the Bank of England considered.

The act restricting the Bank of England from paying its notes in specie, or rather the act by which it obtained this privilege, was, when it was first passed, justified by the necessity of the case. The alarm was so general, that no other expedient remained to save the credit of the Bank. But all sudden and violent alarms are in their own nature of short duration; and when the Parliamentary inquiry, which was commenced into the affairs of the Bank, disclosed in its favour a large balance of accumulated profits, all suspicion of its solvency, and all farther alarm, was immediately done away. In these circumstances, the privilege of refusing specie for its notes being still continued to the Bank, it was necessary to justify this proceeding on different grounds from those urged in favour of the original measure; and with this view, Mr Thornton, the great advocate of the Bank, insists, that, to have enforced the resumption of cash payments, after they were once suspended, at any subsequent period of the last war, would have endangered the credit of the Bank as much as when the first restriction act was passed;—that, after the conclusion of peace, the country was embarrassed by an unfavourable balance of trade, proceeding chiefly from the necessity of making large importations of corn, in order to supply the deficiencies of two successively bad crops,—that the Bank must, in consequence, have been exposed to a continual drain of its specie,—and that the restriction on its cash payments was, therefore, still necessary, as a security against this danger.

We have already endeavoured to show, that the drain of specie to which an unfavourable balance of trade may subject the Bank, can never be such as to endanger its credit, because, in such cases, the demand is neither so rapid nor so considerable as to preclude the Bank from providing the necessary supply of gold. Where trade is in such a state, indeed, the Bank will be exposed to a considerable annual expence in procuring specie. The punctual and honourable discharge of its obligations to the public will frequently be found to be both inconvenient and expensive, and its Directors will naturally be desirous to be free from that which increases responsibility, and diminishes profit. But, unless in the case of a general alarm, and discredit of bank-notes, it does not seem that a suspension of cash payments can ever be necessary to the safety of a bank. It deserves to be considered also, that an unfavourable balance of trade, accompanied by an unfavourable exchange, is in its own nature of short duration. It is an evil which tends to redress itself; a large importation of goods, necessarily leading to an exportation in the same proportion. But, although it is not consistent with the plan of the present article to enter fully into the subject, for the consideration of which at greater length other opportunities will oc-

cur, we may observe, that the foreign exchanges of a country may be influenced by the state of its currency at home, as well as by an unfavourable balance on its foreign trade; and as it is of the first importance to mark the distinction between an unfavourable exchange proceeding from the state of trade, and an unfavourable exchange proceeding from the state of the currency, since the least want of accuracy in this essential point must throw the whole subject into confusion, it is material to remark, that the unfavourable state of the exchange, and the demands for specie to which the Bank was in consequence exposed, which are urged by Mr Thornton as reasons for continuing the restriction on cash payments, have always been ascribed by those who deny the necessity of that restriction, not to the state of trade, but to the depreciation of the paper, in consequence of that over-issue which they maintain to have taken place very soon after the Bank was released from its obligation of paying in specie. Mr Thornton insists, * that if the Bank had been opened to demands for specie, it might, in consequence of the unfavourable state of the exchange, have been exhausted of its cash; and that, to guard against this, it was still necessary to continue the suspension of its cash payments. According to the opposite hypothesis, it is maintained, that the state of the exchange, to which Mr Thornton refers, was connected not with the state of the trade, but with the state of the currency,—that the Bank being now closed against any return of its notes, had issued them in excess,—that having, in consequence, fallen in value, it became profitable to return them upon the Bank for specie,—that the demand for specie, of which the advocates of the Bank complain, was in reality produced by the depreciation of its own notes,—and that the reasons, therefore, assigned by Mr Thornton for the continuance of the restriction, rather prove the necessity of reinforcing on the Bank the obligation of paying in cash, by which means its currency being restored to the value from which it had fallen, the demand for specie would have ceased; and Bank-notes and specie would have been demanded indiscriminately. The one would have answered all the purposes of the other, and the business of the country would have been transacted, as before, with a mixed currency of paper and of gold. It is not to be supposed, indeed, that there were no such occurrences in the history of the country, previous to the year 1797, as unfavourable balances of trade, large importations of corn, in consequence of scarcity, and heavy foreign expenditure, in consequence of war. The Bank, from the time of its first establishment, has had to encounter all the fluctuations incident to peace or war. It has also been exposed to drains of specie from unfavourable balances of trade, as well as from the debased state of the

Banking.

“ Were not the drains from Tuesday the 21st of February to the Saturday inclusive, much greater and more rapid than they had been in the whole of the preceding week?—Certainly; they were unexampled.

“ Did you apprehend imminent danger previous to Tuesday the 21st?—We cannot say we did.

“ When did you first apprehend imminent danger?—We cannot say we apprehended any imminent danger, but from the fears of the drains continuing. Not wishing to risk the drains continuing, we submitted it to the Chancellor of the Exchequer.”—*Report of the Lords' Committee of Secrecy. Minutes, March 1797.*

* *Inquiry into the Nature and Effects of the Paper Credit of Britain, p. 115.*

Banking. currency; but it was not until the year 1797, that its Directors, as a security against those inconveniences, bethought themselves of the singular expedient of dishonouring their own notes. In former periods too, the credit of the Bank was nearly subverted by domestic alarm. A case of this nature occurred in the reign of Queen Anne, when, from the apprehension of a French invasion, the Bank was assailed by an alarming demand for specie. The alarm, however, as is usual in all such cases, soon passing away, the credit of the Bank was entirely re-established, and payments in specie were of course continued during the remainder of the war. The Directors did not venture upon the bold step of making a temporary alarm a pretext for the permanent suspension of their cash payments. They reserved this extreme remedy for extreme cases, not thinking it applicable to those ordinary casualties to which all banks are necessarily exposed.

Bank of England
Notes made legal tender.

At the time when the Bank of England suspended its cash payments, a law was passed, protecting a debtor who offered its notes in payment against arrest, though his creditor, by a common action of debt, might still recover payment in guineas, the legal currency of the country. In 1810, when guineas began to be currently sold for 25s. and 26s. in paper, a law was passed prohibiting this traffic, and imposing severe penalties on those who should exchange bank-notes for less than their nominal value in gold. Tenants, who offered payment of their rents in bank-notes, were at the same time protected against distress, though they were still liable to a common action of debt or of ejectment. In 1811, in consequence of a great landed proprietor announcing that he would exact payment of his rents in guineas, an act was passed, protecting a debtor who offered Bank of England notes in payment of his debt against all farther proceedings. The paper of the Bank of England became, in this manner, legal tender for all existing debts, however depreciated it might be in its value, and the law conferring upon it this important privilege still continues in force.

Chartered Banks of Scotland.

In Scotland, banking has been generally carried on with great prudence and success. There are at present, in the metropolis of Scotland, three banks incorporated by charter, namely, the Bank of Scotland, established by act of Parliament in 1695; the Royal Bank, established by royal charter in 1727; and the British Linen Company, originally incorporated in 1746, with a capital of L.100,000, for the encouragement of the linen manufacture, but afterwards converted into a bank, for the issue of promissory-notes, and the discounting of bills. Those different banks, besides their annual dividends, have been accumulating a fund of undivided profit, which they have, from time to time, been adding to their original capital. The Bank of Scotland and the Royal Bank, have each a capital of L.1,000,000, with an additional L.500,000 subscribed for, but which has never been called up. The capital of the British Linen Company was lately increased from L.200,000 to L.500,000.

Of the country banks in Scotland, it may be remarked, that in most cases they have been established on the security of ample funds; and having con-

Banking. ducted their affairs with prudence, they have generally increased their original capital, and on this account have acquired a great degree of respectability and credit. It is a well known fact, that among the Scotch banks failures have been much less frequent than among the country banks in England.

In no country, perhaps, has banking been carried to such an injurious excess as of late years it has been in Ireland. The national Bank of Ireland was established in 1783, with an original capital of L.600,000, raised by subscription, which was lent to government at an interest of 4 per cent. It was placed under the management of a governor, deputy-governor, and fifteen directors; eight of whom, including the governor and deputy-governor, were to form a court of directors, for managing the concerns of the Bank. They were eligible every year, and it was provided that one third, at least, of the directors should be annually changed.

Bank of Ireland.

In 1809, the Bank of Ireland obtained a renewal of its charter for twenty-one years, on condition that its capital should be increased by L.1,000,000 of stock, to be raised from the proprietary at the rate of L.125 per cent., and to be lent to government at 5 per cent. per annum. The Bank also agreed to continue the management of the public debt and loans, free of expence to government, during the continuance of its charter.

In 1797, when the Bank of England suspended its cash payments, the same privilege was extended to the Bank of Ireland, and after this period its circulation was rapidly increased. The following is an account of the amount of its notes in circulation at different periods:

1797	L. 621,917
1801	2,266,471
1802	2,678,980
1803	2,633,864
1804	2,986,999
1805	2,902,438
1806	2,465,710
1807	2,818,140
1808	2,732,483
1809	3,141,410
1810	3,192,186

This increased circulation of paper appears to have exceeded the wants of the community, since it was followed by rise in the price of bullion, and by the depression of the exchange. About the year 1804, this evil had proceeded to such an extent, that guineas were openly advertised and sold for a premium of 10 per cent., and the exchange with London was about 17 per cent. against Dublin. From this depreciation of the notes of the national Bank many serious evils arose. The silver currency, which circulated in Ireland, was generally in a debased state, and the intrinsic value of the different coins was not equal to the value for which they were current. But by the fall which had taken place in the notes of the Bank of Ireland, those debased silver coins became more valuable in the form of bullion than in the form of currency. They

Banking. were, accordingly, all melted down, and the community being in consequence exposed to the greatest inconvenience, their place was supplied in Dublin and other parts by counterfeits, and in several districts by a paper currency, issued for sums gradually decreasing from 6s. to 6d., and even to 3d. It is calculated by several persons, who gave evidence before a committee of the House of Commons in 1804, that, about this time, there were dispersed throughout Ireland 295 issuers of this paper money, chiefly consisting of a motley body of shopkeepers, merchants, and petty-dealers of all descriptions. The country was inundated with this exceptionable currency, and it was the occasion of such general inconvenience, as well as of such numerous forgeries and frauds, that the circulation of notes for such small sums was at length prohibited by law. Notwithstanding the prohibition, those notes still continued to circulate, the law was evaded by various contrivances, and the want of a better currency secured their circulation. The Bank of Ireland has since made an issue of stamped dollars, which, by supplying the wants of trade, has, in a great measure, remedied the evil complained of.

The premium on guineas, which, in 1804, was 10 *per cent.*, has since greatly declined, and the foreign exchanges of Ireland have also become more favourable. In 1808, guineas were exchanged for paper at a premium of 8d., and paper has since risen nearly to par. As the Bank of Ireland has increased, in place of diminishing, its circulation, since 1804, the cause of this rise in the value of paper must be sought for in the retrenchment of the notes of other banks. It appears, accordingly, that the number of provincial banks has, of late years, been very considerably diminished in Ireland, and that of fifty banks which issued notes in the year 1804, not more than nineteen remained in 1812, the others having either failed or withdrawn from business.* The extinction of so large a portion of the currency would necessarily increase the value of what remained in circulation.

The price of Irish bank-stock has been greatly improved in value within the last twenty years. The following is an account of its price at different periods:

1798	January	90 <i>per cent.</i>
1799	January	115
1802	January	179
1804	January	140
1810		189
1816	September	214

Dividend on Irish bank-stock at different periods.

1798	6½ <i>per cent.</i>
1801	6½
1803	7½
Bonus in 1803	5
1816	10

Bank of France.

In France the progress of banking, as of every other domestic improvement, was retarded by the convulsions of the revolution. But in the year 1803, when the peace of the continent appeared to be secured, and tranquillity prevailed at home, the differ-

Banking. ent banks in Paris were consolidated into one great national bank, called the Bank of France, by an act of the imperial government. The act establishing this bank fixed its capital at 45,000,000 francs, equal to L. 1,875,000 Sterling, to be divided into 45,000 shares of 1000 francs each. It was vested with the exclusive privilege of issuing promissory-notes, payable on demand, in consideration of which, it made large advances to government. Its business was to discount bills of exchange, notes, or bonds; but it was prohibited from carrying on any commerce, except in cash or bullion. The administration of the Bank of France was committed to fifteen directors and three censors, and to these was added a council of discount, consisting of twelve of the principal merchants in Paris, who were to have the privilege of a vote in all matters relative to the discounting of bills. The great body of the proprietors were represented by 200 delegates, chosen from among those possessed of the greatest number of shares, who were to meet annually, or oftener if they were required. To this assembly the affairs of the Bank were to be annually submitted, and the members of the council of discount were to state, whether, in granting discounts, the directors had conformed to the general rules established to regulate their proceedings. These 200 representatives were also to elect the directors, of whom three, and the censors, of whom one, were to be annually changed. It was provided that the dividend for the year (1804) should not exceed eight *per cent.*, to be paid half-yearly, and that whatever profit remained should be invested in the public funds, and allowed to accumulate as a fund of reserve against contingencies. The exclusive privileges of the Bank were granted for fifteen years, commencing from the year 1804.

Under these regulations, the Bank of France commenced its operations; and during the first year of its establishment, its profits amounted to 4,185,937 francs (L. 174,414), being rather more than 12 *per cent.* upon its original capital. Of this sum, 8 *per cent.* was divided among the proprietors; the remainder was invested in 5 *per cent.* stock, as a fund of reserve; and in the following year, the net profit amounted to 4,652,398 francs (L. 193,850). In the latter part of the year 1805, the Bank of France was considerably embarrassed by the drain of its specie, which, in 1806, continued to increase with such rapidity, that the Bank was obliged to suspend its cash payments. Various causes are assigned for this catastrophe, which seems to have chiefly originated in the necessity of making large remittances of specie to the armies then engaged in the Austrian war—in the great advances of the Bank to the Government—in the over issue of its notes—and finally, in vague and unfounded alarms which generally prevailed respecting its solvency. Its notes fell from their standard value, and were exchanged at a discount for specie. The exchange with the country of France became at the same time unfavourable to Paris, to the amount of 12 *per cent.*; and the Bank having restricted its discounts, several important bankruptcies took place, which

* Wakefield's *Statistical and Political Account of Ireland*, Vol. II. p. 171.

Banking. tended greatly to increase the general alarm.* After the peace of the Continent was re-established by the treaty of Presburg, the advances made by the Bank to the government were punctually repaid, and payments in cash were resumed about the commencement of the year 1806. In the course of this year also, in consequence of a decree of the imperial government, a change took place in the administration of the Bank. In place of fifteen directors, its affairs were committed to a governor and two deputy-governors, who were to be appointed by the Emperor. At the same time, its capital, consisting of 45,000 shares of 1000 francs each, was increased to 90,000 shares, or to 90,000,000 of francs.

The new shares were disposed of by the Bank to great advantage, and in consequence of this accession to its capital, it was enabled considerably to extend its operations. By an imperial decree issued at Bayonne, in the year 1808, it was authorized to establish branches in some of the chief provincial towns; and establishments of this nature were begun at Lyons and Rouen, for the purpose of circulating bank-notes, and of discounting bills of exchange. But the merchants of these towns, though they willingly received accommodation from the banks, showed no disposition to circulate their notes. Almost all the notes issued were immediately returned on the Bank for payment; and it is worthy of remark, that neither the notes of the ancient *Caisse d'Escompte*, nor those of the present Paris Bank, have ever obtained any general circulation in the country of France.

In 1814, when France was invaded by the combined armies of Europe, the Bank of Paris was called upon to make large advances to government, and, at this period, its notes in circulation, joined to its other engagements, exceeded by about 20 millions of francs the value of the specie, and other effects of which it was possessed. A general alarm began to prevail; the Bank was exposed to a ruinous drain of its specie; and on the 18th January a resolution was adopted, not entirely to suspend its cash payments, but to limit the sum to be paid in cash to 500,000 francs per day, and not to pay more to each individual than 1000 francs. In February the Bank, having made the necessary arrangements, resumed its payments in cash for all sums, and during the siege and capture of Paris, it continued to pay in cash, even while the cannon thundered at the gates of the city. In like manner, during the subsequent invasion of the country in 1815, payments in cash were not, nor have they ever been since suspended even for a day.

In all the trying situations in which they have been placed, the Directors of the Bank of France appear to have displayed a laudable zeal to fulfil

Banking. their engagements to the public. This bank, like the Bank of England, has frequently been employed as a great engine of state; its funds have been diverted from their proper purposes to assist in the great emergencies of the public service; and its directors, yielding to the pressure of temporary demands, have been forced, for a time, to suspend their payments in cash. But the Bank of France has always resumed the ordinary course of its payments as soon as the alarm and the demand for specie began to abate; while the Bank of England, having once obtained a dispensation from its obligations to the public, seems ever since to have been intent on securing the continuance of this privilege. The example of the Bank of France, which, though it suspended its cash payments, in consequence of the pressure arising from domestic alarm, resumed those payments as soon as the alarm began to subside, may serve to expose the insufficiency of the arguments urged in this country in favour of the continued suspension of cash payments by the Bank of England. The circumstances of the two banks appear to have been precisely similar, and no reason can be imagined to justify the one more than the other in continuing to refuse payment of its notes.

The following is a statement of the affairs of the Bank of France on the 12th August 1816: †

	Francs.	L.
90,000 shares of 1000 francs		
(L. 45 each), -	90,000,000	4,125,000
Fund of undivided profit, -	21,600,000	990,000
	<hr/>	<hr/>
	111,600,000	5,115,000

Investment of this Capital.

	Francs.	L.
In the 5 per cent. Consol. (from which a revenue is derived of 2 millions),	33,500,000	1,395,834
In shares of its own, which it has repurchased (which has the same effect as if, by the rules of its institution, the number of shares had been more limited),	25,500,000	1,062,500
Advances made to government on treasury-bonds, or other securities bearing interest, -	26,000,000	1,083,333
Property, - - -	4,000,000	166,666
Specie and bills, - - -	22,600,000	941,667
	<hr/>	<hr/>
	111,600,000	4,650,000

* *Considérations sur L'Institution des principales Banques de L'Europe, particulièrement sur celle de France.* Par M. Monbrion. 1805. *Rapport fait à la Chambre de Commerce par une commission spéciale sur la Banque de France, et les causes de la crise qu'elle a éprouvée.* 1806.

† The Editor was enabled to furnish the Writer of this article with some of these particulars in regard to the Bank of France, and with this statement of its affairs, by means of a communication kindly made to him by M. Jean-Batiste Say, dated at Paris, on the 14th August last (1816). M. Say is well known as the Author of *Traité d'Economie Politique*, in 2 vols. 8vo, a work, perhaps the most generally sound, instructive, and comprehensive, that has been published on that important science since the appearance of the *Wealth of Nations*.

Banking
||
Banks for
Savings.

Debts owing by the Bank of France on the 12th August 1816 :

	France.	L.
The amount of its notes in circulation, -	70,000,000	2,916,667
Amount of deposits, -	20,000,000	833,334
	<u>90,000,000</u>	<u>3,750,000</u>

Banking
||
Banks for
Savings.

improvement throughout the country, and banks have, in consequence, been established in all the most considerable towns. In 1804, they were calculated, according to the most accurate computation that could be made, to amount to eighty, including ten subordinate banks; and the capital invested in this business was estimated at 50,000,000 of dollars. †

For this sum the Bank has either specie in its coffers, or good bills, generally at the short date of 45 days. If we add to this the sum of 22,600 francs in bills and specie, already stated as part of its capital, it follows that the Bank of France, on the 12th August 1816, was possessed of effects to the amount of 112,600,000 francs (L. 4,691,667). Of this sum it had 41,000,000 francs in hard cash.

The following is an account of the dividends from 1806 inclusive :

	Profit Divided. Francs.	Profit Undivided. Francs.
1805-6.	72 per cent.	80
100 Days of 1806, } to December 31. }	20	2 40
1807.	82	10 29
1808.	73	6 87
1809.	74	7
1810.	74	7 07
1811.	66	3 02
1812.	69 75	4 87
1813.	75 50	7 75
1814.	60*	
1815.	64	2
1816. half-yearly } dividend. }	36	3

The principal American bank is that of the United States, which was incorporated by an act of the Legislature in 1791. By this act, it is provided, that the capital stock shall consist of 10,000,000 dollars, in 25,000 shares of 400 dollars each, one-fourth to be paid in specie, and three-fourths in 6 per cent. stock. The bank is restricted from taking more than 6 per cent. on their discounts, or from advancing more to government than 100,000 dollars. It declares half-yearly dividends, which, from its establishment, have been 4 per cent., with two surplus dividends, one of 1 per cent., and the other of 2 per cent. The date at which it discounts bills is two months.

The late war in which America was involved with Great Britain, seems to have occasioned considerable disorder in the state of her circulation. From the speech of the President to the Congress, in December 1815, it would appear, that the public finances and trade of the United States had been exposed to great inconvenience from the want of some uniform national currency, and from the disappearance of the precious metals. To remedy these evils, it was purposed to establish a new bank at Philadelphia, on the security of such ample funds as should engage universal confidence, and should thus give its notes a free circulation through every part of the United States. A bill, for this purpose, was passed in the last Session of Congress, and it is understood, that the capital required has been since subscribed. (G.)

American
Banks.

In the United States, banking has of late years kept pace with the general progress of wealth and

BANKS FOR SAVINGS. The institutions pointed out by this designation constitute a variety of money-banks, in general, and, to a certain extent, partake of the nature of the class.

Of money-banks, in general, the end is to afford to the owner of money two advantages; the first, safe custody for his money; the second, a profit by it, under the name of interest. Other advantages which banks afford, or are capable of being made to afford, it is not, for the present purpose, necessary to bring to view.

Objects of
this class
of Banks.

The circumstances of the poor man lay him under many disadvantages, as compared with the rich. In this case, we find a particular example. The money of the rich man, being in considerable quantity, easily finds individuals who will perform for it the func-

tions of banking, because it yields an adequate profit.

The money of the poor man, being small in quantity, can find nobody to perform for it the functions of banking, because it is incapable of yielding an adequate profit.

Let us consider the natural tendency of this situation of the labouring man. He can make no profit by money retained. He also lies under many chances of being unable to preserve it. The coarse and imperfect means for shutting his house, or any receptacle which it may contain, exposes his little treasure to the hand even of a clumsy depredator. Accordingly, we find, that persons in the lower situation of life, who acquire a reputation for the possession of hoards, are almost always robbed. If they are disposed to lend the

* To make out this dividend, 194,238 francs were taken from the fund of undivided profit.

† See *Economica, or Statistical Manual for the United States of America*, p. 159, 160.

Banks for Savings.

fruit of their industry and frugality, their limited experience of mankind makes them yield to the man who takes most pains to persuade them; and that is often the man who never means to pay them again, and who has, therefore, the strongest motives to take the measures necessary for gaining their confidence.

Money is for two purposes. It is either for present use, or future use; and wisdom directs that it should be employed for the one or the other, according as, in either case, it is calculated to contribute most to happiness upon the whole. But the poor man is thus deprived, in whole, or in part, of the means of applying his money to *future* use. To this extent, therefore, even wisdom itself would direct him to employ it for *present* use, in whatever way it is capable of adding most to his enjoyments. Parsimony in such a case is hardly a virtue.

The rich are commonly, we cannot say always, very severe observers of the conduct of the poor, and nearly as often unjust. How nearly universal among them are the exclamations against the improvidence of the poor! by which is meant the practice of devoting to present use the whole of their earnings, without reserving as great a portion of them as possible to future use. Amid these exclamations, the degree is totally forgot, in which the poor are deprived of the means of reserving money for future use, and the consequent propriety and prudence of devoting it wholly to present use.

If human happiness is prodigiously improved by reserving for future use a proportion of the command which, over and above the necessaries of life, a man may possess over the means of enjoyment, it is surely desirable that this great instrument of happiness should, in the greatest degree possible, be provided for the most numerous, and in the same degree in which the most numerous, the most important portion of the race. To place it in the power of this portion of the race to secure a share of the good things of life for future use, a system of banking, adapted to their circumstances, is evidently, in the present state of society, in the highest degree desirable. It is one of the means, without which, or something equivalent, the end cannot be obtained.

The question, respecting the utility of banks, adapted to the circumstances of the labouring branch of the population, being thus decided, it only remains, as should seem, to inquire, what is the sort of institution by which the advantages of a bank,—safe custody, and profit for money, can be most completely secured to this great class of the population. When this second question is resolved, the subject, it may be supposed, would be exhausted. The supposition, however, would be erroneous, and the exposition would still remain very imperfect, and even superficial.

When it is ascertained, that banks for the cash of the poor would be useful to the poor, we should act very carelessly, if we remained contented with a mere vague conception of utility in general. To complete the inquiry, we should trace the subject in its ramifications, and pursue them to the very point of termination. We should not be satisfied with a belief that banks will, to some degree, and in some way, we know not what, be useful to the poor. We

should ascertain, with accuracy, in what way or ways, and in what degree, they will tend to increase the happiness of this principal branch of the population.

This is rendered more necessary, by the conduct of those who have chiefly undertaken the patronage of banks for this class of the population. They have been too lavish in their promise of beneficial effects from this desirable institution. They have stretched the vague idea of utility to any extent which suited their imaginations. There is nothing desirable for human beings which they have not described as the natural product of banks for the poor. Happiness and virtue are two things which they will be sure to produce in any quantity we please.

But when gentlemen treat us with these extraordinary promises of good from Savings Banks, they take not sufficient pains to show the connection. They neglect to inform us how the events are to come about. They do not show in what manner, if the one set of things precede, the other things which they so largely predict, must all of them follow. Now, this is not satisfactory. This is to assume and affirm, not to disclose. This is to beg the question, not to resolve it. This way of proceeding not only removes no uncertainty, it has a tendency to draw men upon false ground, and to recommend to them measures for practice founded upon mistaken notions of things, and therefore pregnant with the chances of evil.

The first part of a sound and rational inquiry into the subject of Savings Banks would thus undoubtedly be, to *define* the utility which the institution is calculated to produce; to ascertain exactly the ingredients of which the composition is formed, and the quantity in which it may be expected to exist.

Different Views of the Utility likely to result from Savings Banks.

For this purpose, it may be remarked, that the effects calculated to arise from the institution of Savings Banks are of two sorts; 1st, the immediate; 2dly, the derived. The first result at once from the operations of the Bank. The second arise only from the first, and are, in reality, the effects of the effects.

1. The effects of the first stage,—the effects which immediately result from the operations of the Bank, are two,—safe custody for the money deposited, and interest upon it.

Of these effects no general exposition is required. They are known and familiar to every body.

2. The effects of these effects come next under review. They are more complicated, and far less easy to understand.

It is expected that safe custody for money, and a profit by it, in the shape of interest, will produce a disposition to accumulate. This is the second stage. From this, other effects, which may be called effects of the third stage, are expected.

The disposition to accumulate will produce industry and frugality, which implies temperance. This is the third stage, and these are effects of the third derivation.

Industry and frugality will produce a reserve of wealth. This is the effect of the fourth stage, or fourth derivation.

Banks for Savings.

This reserve of wealth will produce an effect of the fifth stage, namely, security against the miseries of want.

The utility consists in these latter effects, the industry and frugality, the provision against the miseries of want. These, then, are the ingredients of which the compound is formed. The question is, in what degree it may be expected to be produced: in other words, what power can the banks in question possess to produce among that class of the population industry, frugality, and a provision against the miseries of want? It is the resolution of this question which is required at the hands of every one by whom is undertaken an account of a system of banking adapted to the circumstances of the poor.

It is impossible to speak with any accuracy of the circumstances of the most numerous class of the people, without bearing in view the principle of population, or the law according to which the multiplication of the species takes place.

This law is by no means of recent discovery. It had long in political philosophy been regarded as an established fact, that a nation is always peopled up to its means of subsistence; that the only check to population is the want of food; that mankind, as Burke somewhat ingeniously expressed it, "propagate by the mouth;" and that the number of men, if food were not wanting, would double, as the example of America proved, every twenty or five and twenty years. But after establishing this doctrine, the world seemed a long time afraid to look it in the face, and glad to leave it in the situation into which it had been brought. At last, a period arose when men of a certain description began to talk intemperately about the opinion, that the human condition was progressive, and susceptible of indefinite improvement, and men of another description began to be alarmed at this doctrine.

In opposition to the persons who spoke with enthusiasm of this susceptibility of improvement, under the name of the perfectibility of the human mind, Mr Malthus brought forward the principle of population. It was not enough for his purpose to say, that population ascended to the level of food; because there was nothing in that relation inconsistent with improvement, or opposite to the principles of perfectibility. He went, therefore, a step farther, and said, that population rose beyond the level of food; a situation in which vice and misery must of necessity prevail, and unlimited progression was impossible.

Though no part of the doctrine of Mr Malthus has been left uncontested, it is now, among thinking men, pretty generally allowed, that, excepting certain favourable situations, as in new countries, where there is unoccupied land of sufficient productiveness, which may be placed under cultivation as fast as men are multiplied, a greater number of human beings is produced than there is food to support. This, it is understood, is the habitual condition of human nature. The disposition of mankind to marry, and the prolific power with which nature has endowed them, cause a greater number of human beings to be born than it is possible to feed; because the earth cannot be made to increase her produce

so fast as the procreative power of the human constitution increases consumers.

Banks for Savings.

This is the proposition which Mr Malthus added to the doctrine of population; and it is undoubtedly a proposition of extensive import, pregnant with consequences of the greatest moment, and materially changing our views of the measures necessary to be pursued for improving the condition of mankind.

It is perfectly evident, that, so long as men are produced in greater numbers than can be fed, there must be excessive misery. What is wanted then is, the means of preventing mankind from increasing so fast; from increasing faster than food can be increased to support them. To the discovery of these means, the resources of the human mind should be intensely applied. This is the foundation of all improvement. In the attainment of this important end, it is abundantly plain that there is nothing impracticable. There is nothing which offers any considerable difficulty, except the prejudices of mankind.

Of this doctrine, one of the facts which it is on the present occasion peculiarly necessary to carry in view, is the mode in which the misery in question, the misery arising from the existence of a greater number of human beings than there is food to maintain, diffuses itself.

For a share of the food which is brought into existence, the greater part of mankind have nothing to give but their labour. Of those who are endeavouring to purchase food by their labour, there is not enough for all; some must want. What is the consequence? Those who are in danger of being left out in the distribution, offer more labour for the same quantity of food; that is to say, they agree to work for less wages; by this competition, the wages of labour are reduced, and made so low that they are not sufficient to procure food for the families of all the labourers. The whole are placed in the lowest and most afflicting state of poverty; and of those whose wants are more than usually great, or supply more than usually small, a portion must die, from the want of a sufficiency of the necessaries of life. The state of wages is sufficient to afford the means of existence to as many as the food produced can barely preserve alive; the superabundance, who, by their competition, have rendered thus miserable the situation of the rest, must inevitably perish. Whatever the state of production in regard to food, the wages of the labourer are sufficient to enable the labourers, as a body, to raise a number of children sufficient to keep up the population to the level of the food. The labourer who has the number of children correspondent to that increase, has just enough to keep his family alive, and no more. Those who have a greater than this number, and not a greater than the usual means of procuring food, must partially starve.

This is the natural unavoidable condition of the greater part of mankind, so long as they continue to produce numbers greater than can be fed. The question then is, what are the effects which, in this situation of mankind, the institution of banks for the savings of the poor are calculated to produce?

Every thing, as we have already seen, is to be derived through the medium of the disposition to accumulate.

Banks for Savings.

But the disposition to accumulate, as far as men are wholly deprived of the means of accumulation, is out of the question; for either it is wholly incapable of existing, or exists to no manner of purpose.

Of the labouring people, however, who have families, all but those of whom the families are uncommonly small, or who possess uncommon advantages, are, according to the principle of population, either in a state of starvation, or upon the very brink of it, and have nothing to accumulate.

The unmarried part of the population, therefore, those who have no families, or those who have very small ones, are those alone to whom the institution of savings banks can present any motives whatsoever. The question is, what are the effects which will be produced upon society by the motives which it presents to this reduced part of the population?

That it will increase to a certain extent the disposition to accumulate, may naturally be expected. To how great an extent, general principles afford us no means of very accurately foreseeing. We must wait for experience to determine. In the meantime, we know that single persons are for the most part young; and that youth is not the season when the pleasures of the present moment are most easily vanquished by those of the future. The training of the human mind must be more skilful, and more moral to a vast degree, before this salutary power will belong to any considerable portion of the youth in any class of the population, especially in the least instructed of all.

Let us next inquire the tendency which it will possess, whatever the degree in which it may be expected to exist.

In the first place, it will produce an abstinence from such hurtful pleasures as are attended with expence. Under this description is included the pleasure of intoxicating liquors, and no other possibly whatsoever. There is hardly any other indulgence on which any portion, worth regarding, of the earnings of the poor is bestowed, which can at all deserve the name of hurtful, or from which there would be any virtue in abstaining, if the means of obtaining it were enjoyed in sufficient abundance. To this, then, the moral effect of savings banks may be supposed to be very nearly confined. But assuredly this, if it can be produced in any considerable degree, must be regarded as an effect of no ordinary importance.

Passing from the moral effects, we come to the accumulation which it may be in the power of the unmarried part of the population to make. To this, and what may spring out of it, all the remaining effects of savings banks are evidently confined.

A part of the unmarried population will make accumulations, and undoubtedly they ought, if possible, to be provided with the means of doing so. Let us suppose that the greatest part of them profit by those means. What consequences are we able to foresee?

Of unmarried persons there are few who are not looking forward to the married state, and few by whom, sooner or later, it is not entered. As soon as persons of the lower class are married, or, at any rate, as soon as they have a certain number of

children, their powers of accumulation cease. But there is a previous hoard: What becomes of it?

It is either wholly expended, at the time of marriage, upon the furnishing of a house; or it is not.

If it is wholly expended upon the furnishing of a house, it contributes to present enjoyment, like any other expence whatsoever; like that, for example, of a fine coat; and forms no longer a provision against a day of adversity and the evils of want.

Let us suppose that it is not wholly expended upon the furnishing of a house, but that a portion, at least, of it remains. This, it will be said, is reserved as a provision against want; and of this the beneficial effects may be reckoned sure. But abstracting from extraordinary cases of bad health, least common in the earliest stage of the married life, and other extraordinary accidents, the first pressure will arise from the increase of the family. After that number of children is born, which exhausts the earnings of the father, the birth of another child produces the miseries of want. If there is no fund remaining from former accumulations, hardship introduces death, and the amount of the population is thus, upon the whole, kept down to the level of the food. If there is a fund remaining from former accumulations, it will now of necessity be consumed; and by its consumption will enable the family to go on a little longer; to rear a child or two more. But the number of children reared was before as great as there was food to maintain. If a greater number is raised, there is an excess of population, who bid against one another for employment, and lower the wages of labour. Already, the great mass of the population were in a state of unavoidable misery from the lowness of wages. An increase of poverty is now brought upon them; and their situation is rendered more deplorable than it was before. It is impossible not to consider this as one of the effects, which a fund accumulated before marriage, by the laborious part of the community, has a tendency to produce. And this is a tendency altogether noxious.

The greater part of those who have talked and written about savings banks have left the principle of population altogether out of their view. They have, therefore, left out of their view that circumstance on which the condition of the most numerous class of mankind radically, and irremediably, and almost wholly depends. Of course, their observations and conclusions are of little importance.

Others, whose minds are philosophical enough to perceive the influence of the principle of population upon the condition of the great bulk of mankind, are of opinion, that savings banks will have a salutary effect upon the principle of population, and ameliorate the condition of mankind, by lessening the rapidity with which they multiply. This is a speculation of the deepest interest. If this be an effect of savings banks, they will, indeed, deserve the attention and patronage of the philanthropist and the sage.

The following is the mode in which the authors of this opinion believe that the happy effects which they anticipate will take place. The means of profiting by the reserve of a portion of their earnings,

Banks for Savings.

Banks for Savings

which savings banks will provide for the unmarried part of the labouring people, will give them, it is supposed, a taste for accumulation: Aware of the impossibility of accumulating after marriage, their desire of accumulation will make them defer the period of marriage: Of deferred marriages, the result will be a less numerous offspring: A smaller number of people in proportion to the food will be reared: The competition for food will be reduced; the competition for hands will be increased; wages will rise; and the cruel poverty of the mass of the population will be abated.

In this deduction, nothing is doubtful, unless the commencing step. If the desire created in young persons for accumulation is sufficiently strong to produce any considerable postponement of the period of marriage, all the other effects will necessarily follow; a reduced number of children; an increased reward of labour; and a correspondent amelioration in the condition of the greatest portion of the race. Savings banks will prove one of the most important inventions, to which the ingenuity of man has yet given existence.

It would be rash, however, to claim as an ascertained fact, that savings banks will have the effect of retarding the period of marriage. There are persons who hold the very opposite belief. They say, that what chiefly retards marriage at present among the better part of the labouring population, among those who have a regard to appearance, and a value for respectability, is the want of means to provide the furniture of a house; that savings banks will enable them to provide that furniture at an earlier period than at present; and that the institution will therefore accelerate the period of marriage, increase the number of those who cannot be fed, and thus add to the calamities of mankind. They ridicule the idea, that the love of saving will become, in the breast of young persons, a match for the passions which prompt them to marriage.

If we consider accurately what takes place among mankind, we shall probably conclude that both effects will be produced; that the love of saving will, no doubt, induce some persons to defer the period of marriage; but that the means of furnishing a house, placed at an earlier period within their reach, will produce the very opposite effect in regard to others.

The question is, which class is likely to be the most numerous? and this is plainly one of those questions to which no very certain answer can be given. But if we consider the strength of the passions which urge to marriage, we shall probably suspect that it will not be easy for the love of saving to acquire an equal force in the breast of any considerable portion of persons who are young, whose education has been very bad, and who hence have little power either of foresight or of self-command.

Such are the different views which may be taken of the effects which banks for the savings of the poor will produce. The exposition is useful to check the intemperate conclusions of enthusiastic patrons, and to show that much more than the mere institution of savings banks is necessary to produce any considerable amelioration, either in the physical or moral

state of the poor. In conjunction with other causes, savings banks are not only desirable, but necessary. The noxious consequence will be, if those who have it in their power to do more, shall suppose that savings banks are sufficient to do all, and there should limit their exertions. Taken by themselves, it is at least a doubt whether savings banks may not produce as great a quantity of evil as good.

Banks for Savings

It now remains that we should give an account of the measures which have been taken for the establishment of savings banks, and endeavour, if we can, to ascertain the most useful form which they are capable of receiving.

We are not aware that the idea of an institution, answering in any degree the description of a savings bank, was in this country expressed in public before the year 1797, when a peculiar scheme for the management of paupers, or persons deprived of the means of maintaining themselves, was published by Mr Bentham in Young's *Annals of Agriculture*. It would require too long a digression to give an account of this plan of Mr Bentham, which embraces a great number of points, and would require an exposition of considerable complexity. Of that plan, one part consisted in the institution of what he distinguished by the name of a *frugality bank*.

The series of wants to which it was by him destined to operate as a remedy, were as follows:

1. Want of physical means of safe custody, such as *lock-up* places; thence, danger of depredation, and accidental loss.

2. Difficulty of opposing and never-yielding resistance to the temptations afforded by the instruments of sensual enjoyment, where the means of purchasing them are constantly at hand.

3. Want of the means of obtaining a profit by the savings of the poor, or the use of them in portions adapted to their peculiar exigencies.

4. Want of a set of instructions and mementos constantly at hand, presenting to view the several exigencies, or sources of demand for money in store, and the use of providing it.

He next proceeded to sketch the properties which appeared to him to be desirable in a system of frugality banks, commensurate to the whole population of the self-maintaining poor. These were,

1. Fund, solid and secure.

2. Plan of provision all-comprehensive.

3. Scale of dealing commensurate to the pecuniary faculties of each customer.

4. Terms of dealing sufficiently advantageous to the customer.

5. Places of transacting business suitable; viz. in point of vicinity, and other conveniences.

6. Mode of transacting business accommodating.

7. Mode of operation prompt.

8. Mode of book-keeping clear and satisfactory.

In the plan, however, of the bank which Mr Bentham contemplated for answering the purposes which he thus described, he did not direct his view to that simplest of all the forms of banking, the mere receipt of money, to be paid again with interest when demanded; the form to which the patrons of savings

Banks for Savings.

banks at present appear judiciously to confine their attention. Mr Bentham's proposal was to receive into the frugality banks the deposits of the poor, not for the mere purpose of yielding an interest, and being withdrawn when wanted, but to form or purchase an annuity for old age, when the power of earning would be either destroyed or impaired.

That the accumulation of the poor might not, however, be confined to one exigency, though that the greatest, he proposed that this superannuation annuity should be convertible, in the whole or in any part, into any other species of benefit, adapted to the exigencies of the owner. It might, for example, be converted into an annuity for an existing wife, in the event of widowhood. It might be converted into an annuity during the nonage of a certain number of children. It might serve as a pledge on which to borrow money. Part of it might be sold to raise a marriage fund, or it might be simply withdrawn.

Mr Bentham then proceeded to compare the effects of a system of frugality banks with those of friendly or benefit societies. To this comparison, however, we cannot with any advantage proceed, till that other species of institution is first described. We are, therefore, inclined to reserve it wholly to the article *BENEFIT SOCIETIES*, to which the reader is referred.

It is somewhat remarkable, that no allusion which we can perceive in any of the numerous pamphlets to which the subject of savings banks has lately given birth, is made to this early scheme of Mr Bentham; though the work in which it is contained not only appeared in a periodical and popular publication so long ago, but was laid upon the table of the committee of the House of Commons, appointed to inquire into the subject of Penitentiary Houses in 1811, and referred to in the appendix to their report; and was published separately in one 8vo volume, in 1812, under the title of *Pauper Management improved*.

As no attempt was made to carry Mr Bentham's plan of pauper management into practice, his scheme of a frugality bank, as a part of it, remained without effect.

The first attempt, as far as our researches have been able to discover, to give actual existence to the idea of a bank adapted to the exigencies of the poor, was owing wholly to a lady, to whom the public are indebted for several excellent productions of the pen, and who never took up her abode in any place, while health and strength remained, without endeavouring to perform something of importance for ameliorating the condition of those by whom she was surrounded. Mrs Priscilla Wakefield, the lady to whom we allude, residing, in the year 1803, at Tottenham, in Middlesex, a populous village, within a few miles of London, not only projected, but was the means of instituting, and the principal instrument in carrying on, a bank at that place for the savings of the poor. An account of this institution, drawn up by Mrs Wakefield, and dated the 24th of May 1804, was published in the fourth volume of the *Reports of the Society for Bettering the Condition of the Poor*. The account is so short, and so much to the purpose, that it may with advantage be inserted here.

“ Extract from an *Account of a Charitable Bank at Tottenham for the Savings of the Poor*, by Mrs Wakefield. Banks for Savings.

“ For the purpose of providing a safe and convenient place of deposit for the savings of labourers, servants, and other poor persons, a charitable establishment has been lately formed at Tottenham, in the county of Middlesex. It is guaranteed by six trustees, who are gentlemen of fortune and responsibility, most of them possessing considerable landed property. This renders it as safe and certain as institutions of this kind can be, and insures it from that fluctuation of value to which the public funds are liable. The books are kept by a lady, and never opened but on the first Monday in every month, either for receipts or payments. Any sum is received above one shilling; and five *per cent.* is given for every 20s. that lies 12 kalendar months; every person so depositing money being at liberty to recal it, any day the books are opened; but no business is transacted at any other time.

“ The money so collected is divided equally between the six trustees. For every additional L.100, a new trustee is to be chosen; so that a trustee can only risk his proportion of L.100. None but the labouring classes are admitted to this benefit; and there is no restriction as to place of residence.”

“ OBSERVATIONS.

“ These few simple rules are all that have hitherto been found necessary for the establishment of this charity, the design of which is both original and useful. To those who have applied themselves to that branch of political economy which relates to increasing the comforts, and improving the morals of the inferior classes of society, it must be obvious that every endeavour to encourage and enable them to provide for their own wants, rather than to rely upon the gratuitous gifts of the rich, are of great advantage to the whole community.

“ It is not sufficient to stimulate the poor to industry, unless they can be persuaded to adopt habits of frugality. This is evinced amongst many different kinds of artisans and labourers, who earn large wages, but do not in general possess any better resources in the day of calamity than those who do not gain above half as much money. The season of plenty should then provide for the season of want, and the gains of summer be laid by for the rigours of winter. But it must be obvious how difficult it is for even the sober labourer to save up his money, when it is at hand to supply the wants that occur in his family. For those of intemperate habits, ready money is a very strong temptation to the indulgence of those pernicious propensities.

“ Many would try to make a little hoard for sickness or old age, but they know not where to place it without danger or inconvenience. They do not understand how to put money in, or to take it out of the bank; nor will it answer for small sums, either in point of trouble or of loss of time. The same causes frequently occasion thoughtless servants to spend all their wages in youth, and in consequence to pass their old age in a workhouse,—a sad reverse from the indulgence of a gentleman's family, to which they have

Banks for Savings.

been habituated. Many instances indeed have occurred, that, for want of a place of security for their money, the poor have lost their hard earned savings, by lending it to some artful or distressed person, who has persuaded them it will be safe in his hands.

"The success of the little bank for children, connected with the Tottenham Female Benefit Club, mentioned in a former part of the reports, encouraged the present design; and it may be worth remarking, that the bank was opened by an orphan girl of fourteen, who placed L.2 in it, which she had earned in very small sums, and saved in the Benefit Club."

In 1805 and 1806, two pamphlets were published by Mr Bone, in the first of which he seems to have had it chiefly in view to point out the objects to which a scheme for preventing among the poor the miseries of want ought principally to be directed; in the second, to sketch the form of an institution by which those objects might be obtained. The scheme of Mr Bone is, however, nearly as comprehensive as that of Mr Bentham, and, therefore, extending far beyond the subject to which the present article is confined. The following are its principal objects:

1. To provide comfortable dwellings for all who require them.
2. Sums for their maintenance.
3. A provision for widows and children, education for the latter included.
4. Endowments to children at 21 years of age.
5. Temporary dwellings to destitute strangers.
6. To afford small loans.
7. Provision for persons who have belonged to the army or navy.
8. To grant annuities to persons to whom that mode of assistance is the best adapted.
9. To afford a provision for persons lame, or otherwise disabled.
10. To procure situations and employment for those deprived of them.
11. To nurse and educate children, as many as possible of the children of those who are themselves the least qualified for the task.
12. To provide baths and lavatories for the poor.

To the accomplishment of this scheme, banking, however, contributes a diminutive part. It is not proposed that all this should be accomplished by the funds of the poor themselves. The receipt, however, of the contributions of the poor, forms an essential article of the plan, and so far it involves in it the principle of a savings-bank. It was proposed to receive the contributions of single persons, and return them with premiums at the period of marriage; to receive, farther, the contributions both of the single and the married, with a view to the future and ultimate provision; for though all persons would, according to this scheme, receive a provision, it would be a provision with more or less of excellence, according to the contributions of the individual.

In 1807, the minister of the parish of West Calder, in Scotland, founded a bank for the savings of the principal class of his parishioners; and in 1810, without any knowledge of what had been accomplished in West Calder, Mr Duncan, the minister of Ruthwell, another of the Scottish parishes, established one in his own, in nearly a similar form. Mr

VOL. II. PART I.

Banks for Savings.

Duncan, in a well written pamphlet, in which he describes the form of his own institution, and explains the object which the system has in view, and the principles upon which it is founded, informs us, that his idea of an economical bank for the savings of the industrious, was accidentally suggested to him by a perusal of the pamphlet, entitled, *Tranquillity*, of Mr Bone, at a time when his mind was peculiarly excited to the consideration of the subject, by the circumstances of the poor in the town and vicinity of Dumfries, and by the threatened approach of what he deemed a national misfortune, the introduction of poor-rates.

The course pursued by Mr Duncan is in the highest degree instructive. It is founded upon an accurate knowledge of human nature, in which the men who step forth from elevated situations to ameliorate the condition of their fellow-creatures, are in general singularly deficient, and therefore most commonly reap nothing but the natural fruit of injudicious measures—disappointment. As a great effect was intended to be produced upon the minds of the people, Mr Duncan saw the necessity of carrying the minds of the people along with him, and of adopting the most powerful means for making them feel and take an interest in the concern. Unless the interest is felt, and powerfully felt, the operation of the machinery will be feeble, and its effects trifling. Novelty may give it some appearance of strength for a time, but this will gradually decay.

In the first place, it was necessary that every cause of obstruction should be removed. "The prejudices of the people should be carefully consulted; they should be treated even with delicacy; and the most unreasonable scruples of the ignorant and suspicious should, as far as possible, be obviated." It is not duly considered by the upper ranks of the population, how inseparable from human nature are the suspicions of those who are weak, toward those who are strong; the suspicions of those who are liable to be hurt, toward those who are capable of hurting them. And it is only the blindness of self-love, and our inattention to evils in which we are not called to participate, that leave us ignorant of the actual grounds in practice, whence, even in this country, the institutions of which are so much more favourable than those of most other countries to the poor, the weak have reason to dread the interference of the strong.

So much for removing the causes of dislike. More is necessary to create a positive, and still more to raise an ardent attachment. The springs of human nature must be skilfully touched. Mr Duncan knew where to find them, and he looked to the means which the circumstances of the case afforded for placing them in action. "It may be observed in general," he says, "that in all those situations, where it is practicable to assimilate the mode of management to the scheme of Friendly Societies, the advantage to be derived from such a circumstance ought not to be overlooked." If there were nothing in the case but the actual existence of these societies, and the favour with which the people regard them, the importance of this advice would still be more than considerable. But, says Mr Duncan, "On this subject, it may be proper to attend to the following

Savings Banks in Scotland.

Banks for Savings.

remarks: Those who are at all acquainted with the history of friendly societies, must be aware, that they owe much of their popularity to the interest excited among the lower orders, by the share to which each of the members is admitted in the management of the institution. The love of power is inherent in the human mind, and the constitution of friendly societies is calculated to gratify this natural feeling. The members find, in the exercise of their functions, a certain increase of personal consequence, which interests their self-love in the prosperity of the establishment. Besides, by thus having constantly before their eyes the operation of the scheme, in all its details, they are more forcibly reminded of its advantages; and not only induced to make greater efforts themselves for obtaining these advantages, but also to persuade others to follow their example. Hence it happens, that a great number of active and zealous supporters of the institution are always to be found amongst the members of a friendly society, who do more for the success of the establishment than can possibly be effected by the benevolent exertions of individuals in a higher station."

For these reasons Mr Duncan held it expedient to give the contributors themselves a share in the management of the institution; and that share was well chosen. The contributors in a body were not fit to be the acting parties; but they were fit to choose those who should act for them. A general meeting is held once a-year, consisting of all the members who have made payments for six months, and whose deposits amount to L.1. By this meeting are chosen the court of directors, the committee, the treasurer, and the trustee, the functionaries to whom the executive operations are confined. And by this also are reviewed and controlled the transactions of the past year, with power to reverse the decisions of the committee and court of directors; to make new laws and regulations, or alter those already made; and, in other respects, to provide for the welfare of the institution.

The power of choice is somewhat limited by the qualifications required. The society consists of two sorts of members, the ordinary, and the extraordinary, and honorary. The general meetings have alone the power of electing honorary members; but the Bank Trustee, the Lord-Lieutenant and Vice-Lieutenant of the county, the Sheriff-depute and his substitute, the members of Parliament for the county and burgh, the ministers of the parish, with certain magistrates of the town, are honorary members *ex officio*; and there are certain regulated subscriptions or donations, of no great amount, which constitute the person paying them, *ipso facto*, an extraordinary or honorary member. Now, it is from this list of honorary and extraordinary members that the choice of functionaries by the general meeting is annually to be made, provided a sufficient number of them should be disposed to accept of the offices designed; if not, from such of the ordinary members as make deposits to the amount of not less than L.2, 12s. in the year.

It is not fitting here to enter into the details of the organization, or those of the executive arrangement. It is sufficient to state, that deposits are received in sums of 1s., bear interest at the amount of L.1; and are

always payable, with compound interest, on a week's notice.

Banks for Savings.

It seems not to have been till 1814 that the project of savings banks made any farther progress in Scotland. In that year, "the Edinburgh Bank for Savings was instituted," says Mr Duncan, "by a society of gentlemen, of the first influence and respectability; who, from their enlightened labours in the suppression of mendicity, and in the establishment of a permanent provision for the poor, had already acquired no trifling claim to the confidence and affection of the public, and particularly of the lower orders." In the constitution of this bank, the interference was rejected of the depositors themselves; who were simply required to confide their money in the hands of the gentlemen who undertook the management of the institution. "This circumstance," says Mr Duncan, "has operated as a powerful obstruction to the success of the plan. The truth of this will appear in a very striking point of view, if we contrast the progress of the scheme in Edinburgh with that of the Ruthwell parish bank, or of those institutions which are formed on a similar plan." And he then presents a statement of facts, which fully support the position, and strongly illustrate the importance of the principle on which the Ruthwell institution was founded.

Mr Duncan, from deference to the gentlemen who made the decision for the Edinburgh bank, seems willing to allow that a general meeting of all the contributors, and a reservation to that meeting of certain appropriate powers, useful and important as it is, may, in great cities, such as Edinburgh, be attended with inconveniences which outweigh its advantages. May not this, however, be a concession too easily made? It would, at least, be desirable to have good reasons presented for the sacrifice of so great an advantage, before we consent to its being made. There is an obvious inconvenience in assemblages of people, of any description, when too large. And if one bank were to serve for the whole of a great city, and the contributors should amount to any considerable part of the population, the assemblage would undoubtedly be too large. But this, under the circumstances in contemplation, would not be the case. To accommodate the customers, there ought to be a bank in every parish, or similar district. There would be no greater inconvenience in calling together the moderate number of contributors to such a bank in a city, than in the country. The fact is proved by the ample experience of friendly societies; the members of which do actually meet much oftener than once a-year, and devoid of many advantages which the mixture of persons of the upper classes would afford to the association of a savings bank. If any central, or general institution, to give unity and combination to the operations of the different banks of a great city, were found to be useful, it might be formed of delegates chosen by the committees of the several district or parochial banks; and thus, without any inconvenience that can be rationally contemplated, all that fervent interest which is the natural effect of giving the contributors themselves a part to act in the formation and conduct of savings banks, would be provided for and secured. In London itself,

Banks for Savings.

there are various institutions, wholly dependent upon voluntary contributions, the subscribers to which, though extremely numerous, are annually called together for the election of committees and other managers. The society of *Schools for All* may be adduced as a conspicuous example. And where is the inconvenience that is ever found to result?

Savings Banks in England.

In the meantime, efforts were begun for the extension of the system in England. In the year 1813, a judicious and successful attempt was made by Dr Haygarth for the establishment of a bank for savings at Bath, where, sometime before, an institution, under the name of a servant's fund, had been formed on nearly similar principles, at the suggestion of Lady Isabella Douglas, sister of the Earl of Selkirk.

The circumstances of England were in several respects much less favourable to any plan founded upon the savings of the poor than those of Scotland. The disadvantages existing in England are justly enumerated by Mr Duncan, under four heads; 1st, The character and habits of the people; 2dly, The nature of the ecclesiastical establishment; 3dly, The system of poor laws; 4thly, The state of the banking business.

The first three are general, and the nature of the obstruction which they afford in some degree obvious. The illustration of these here may therefore be waved. The last, however, so intimately concerns the operations of the banks for the poor, that it requires a difference even in their constitution. It is the practice of the banks of Scotland to allow interest for the monies deposited with them; and so perfect is the foundation on which some of them are placed, that the security attached to the deposits they receive, is equal to that of the Bank of England itself. The operations of the economical bank are here, therefore, simple in the highest degree. It has only to open an account with one of these banks, and pay to the contributors the interest received, making such a deduction as the expences of the institution may require.

In England it is not customary for banks to allow interest on the deposits which are made with them. And where possibly interest might be obtained, the security would not always be good. The savings banks have no source whence interest can be derived with the due measure of security, except the public funds. But, with respect to them, a great inconvenience arises from the fluctuation of price. What is desirable, above all things, is such a degree of simplicity and plainness in the transactions, that the reasons of every thing may be visible to the uninstructed minds of the people with whom the institution has to deal. But this fluctuation in the price of stock is an unavoidable source of complication and obscurity. The money of one man produces more, that of another less, according to the price of stock, at the time when his deposit is made. When it is withdrawn, a sum is received, greater or less than that which was put in, according as the price of stock has risen or declined.

The plan upon which Dr Haygarth proceeded, in the bank which his strenuous exertions were the means of setting on foot in Bath, was to make every depositor, to the value of one or more pounds of stock, a proprietor of stock to that amount, and en-

Banks for Savings.

title him to receive his dividends every six months, the same as those paid at the Bank of England, one sixth being deducted for the expences of the institution. In the constitution of this bank, no part of the management, and no control over it, were given to the depositers. Certain trustees and managers were constituted, with powers of supplying vacancies; and the money of the depositers was vested in the funds in the names of a certain portion of the trustees.

In the month of November 1815, a bank was projected for the town and vicinity of Southampton, to which the zeal and influence of the Right Honourable George Rose in a great degree contributed. In the formation of this institution, the model of the Edinburgh bank was principally followed. It was composed of a certain number of noblemen and gentlemen, who formed themselves into an association for banking the money of the poor; excluding entirely the intervention of the depositers. It differed from the bank established at Bath, which gave the depositers a proportion of the dividends, and left them to the chance of gain or loss by the fluctuation of the stock which their money had purchased; the Southampton bank, though it vested the money in government securities, undertook to pay a fixed invariable interest of 4 per cent. on each sum of 12s. 6d.; and to repay the deposit when demanded, without addition or diminution. The chance of any rise or fall in the price of the funds, the bank, in this way, took upon itself. The Southampton, like the Edinburgh bank, limited the amount of deposits which it would receive from any one individual; and fixed the sum at L. 25.

Some attempts were also made in London. A bank was instituted, under the influence of Barber Beaumont, Esq. in the parish of Covent-Garden. A committee of the inhabitants of the parish, rated at L. 50 and upwards, together with the members of the vestry, form one committee, and twenty-four of the depositers, chosen by themselves, form another committee, who jointly choose their agents, and conduct the business. The want of security in this plan is an obvious objection; the money remaining in the hands of certain individuals, in the character of treasurers, allowing interest at 5 per cent.

A bank was opened in Clerkenwell, another parish in the metropolis, on the 29th of January 1816, chiefly through the instrumentality of Charles Taylor, Esq., on a plan by which the depositers appoint their directors, their committees of accounts, their superintendents, &c. from their own number, and thus conduct the business of the institution wholly for themselves. The treasurer is allowed to retain to the amount of only L. 200, for which he gives security, and allows interest at 5 per cent. for the sum in his hands. The other funds are invested in government securities. The great defect in this otherwise admirably constituted institution, seems to be the limiting the choice of managers and functionaries to the depositers themselves. Why should the depositers deprive themselves of the advantage of choosing a person who would be eminently useful as a manager, though not of a rank of life to require the institution for his own use? If the depositers have the power of choosing, for the management, whom they

Banks for Savings.

please, depositors or not, they will have all that share of action which is necessary to establish their confidence and animate their zeal; while, at the same time, men of superior education and influence may be joined with them, and prevent, by their wisdom and authority, any error to which the business might be otherwise exposed. As often as men of superior education and fortune showed a disposition to render themselves useful in the conduct of the institution, daily and universal experience prove how certainly and gladly they would be chosen. In the meantime, the prosperity of the Clerkenwell bank is a complete proof of the safety with which that co-operation of the contributors, the utility of which is so well demonstrated by Mr Duncan, may be employed in the greatest cities. Clerkenwell is a parish, a great part of which is inhabited by some of the poorest people in the metropolis; the establishment of the bank was attended with nothing which was calculated to excite any attention; with advertisement scantily sufficient to make it known in the district; yet on the 22d of April, less than three months after the time of its institution, it had 157 depositors, and had received L. 269, 11s. 6d.

These local and confined attempts in the metropolis were followed by others on a larger scale. The *Society for Bettering the Condition of the Poor* took measures for interesting a sufficient number of noblemen and gentlemen to establish a grand Savings Bank, or Provident Institution, which was deemed a preferable name, for the whole of the western half of the metropolis. Several meetings of persons of high rank and others were held during the month of March 1816. The plan of the bank of Southampton, to pay a certain fixed rate of interest, and return the neat deposit on demand, was first proposed. This, with regard to the facility of giving satisfaction to the contributors, and avoiding all misconception on their part, injurious to the prosperity of the institution, was highly desirable. But, after a due consideration of the danger to which the institution would, on this plan, be exposed, in the event of any great depression of the price of stock, it was resolved to follow the example of Bath; to render each depositor a stockholder, and consequently himself liable to either the profit or the loss which the fluctuation of stock might occasion. This institution was composed of the noblemen and gentlemen by whom it was promoted, who formed themselves into an association, consisting of a president, vice-president, trustees, and managers; wholly excluding the co-operation of the depositors, and all intervention or control on their part. This institution was opened in Panton Street, Hay Market, on the 15th of April following; and another, promoted by the principal gentlemen in the city, and founded on similar principles, was soon afterwards opened in Bishopsgate Street, for the eastern half of the metropolis.

Of the bank for the western division of the metropolis, a particular account has been published by Joseph Hume, Esq. one of the managers, which deserves attention, as containing a valuable set of practical rules for the detail of the business, according to the principles on which that institution is founded; and, above all, as containing the description of a sys-

Banks for Savings.

tem of Book-Keeping, admirably adapted to the purpose of savings banks in general, and of which that gentleman himself was the principal contriver.

By Mr Hume and Dr Haygarth, we see that the term *Provident Institution* is applied as the name of those associations which have it for their object to enable the poor to place their money in the stocks. The term Bank, whether called a Savings Bank or a Frugality Bank, they would confine to these institutions which pay a fixed interest, and return the neat deposit. The term Bank, however, is equally applicable to both, and the best denomination they can receive. Some adjunct is wanted to distinguish this from other species of banks, and no good one has yet been found. Neither *Frugality* nor *Savings* is distinctive; every bank is a frugality bank. *Poor's Bank* would be the best, but for one conclusive objection, that it is humiliating, and in common acceptation disparaging.

As government securities afford in England the only expedient, attended with safety, for employing the deposits of the poor; but as these securities are, at the same time, attended with the great inconvenience of fluctuation, and require the transmission of the money to and from the metropolis, of which the inconvenience would often be considerable; Mr Hume is of opinion, that the powers of government should be employed for the removal of these two inconveniences, which would merely afford to banks for the poor in England those advantages which they already enjoy in Scotland, from the admirable state of the banking business. The effects might be accomplished by the payment of the money to the receiver of each county, and by the receipt from him of the proper returns. This would no otherwise change the nature of the transaction, than that the money would thus be lent to government in a way extremely convenient to the poor, while, by purchase into the public stocks, it is still lent to government, but in a way far from convenient to that class of the people.

There may be, and there are, solid objections to the rendering any great portion of the people the creditors of government, as being unfavourable to that independence of the people on the government, on which all security for good government depends; but if the people are to be rendered the creditors of government, there can be no objection to them being rendered so in a way convenient to themselves, rather than in a way which is the contrary. And if there is no other security but that of government to which the banks for the poor can have recourse, we are reduced to the alternative of either having no banks for the poor at all, or lending the money to government. It will occur to some persons, that it might be lent to the parishes on the security of the poor-rate. But to those who contemplate the abolition of the poor-rate, this will not appear desirable as a permanent expedient. If counties were managed according to their ancient constitution, the best plan might be, to lend it to the counties, on the security of the county rate. But even in this case, it could not be lent without admitting a prodigious evil, the principle of county debts.

No mention has been made of the plan of Mr Baron Mazeret, in the account which has been rep-

Banks for Savings
||
Bannockburn.

dered of the successive steps by which the business of savings banks has been brought to its present state; because it was not conceived that this plan corresponded to the idea of a savings bank. It is, however, necessary to be described, because it is not impossible that some of the ideas realized in savings banks may have been derived from it. The plan of Baron Mazerés was a proposal for establishing life-annuities in parishes, for the benefit of the industrious poor. It was published in 1772, accompanied with the suggestion of certain alterations by the celebrated Dr Price. It was recommended to the nation to obtain a law, for enabling the parish officers in England to grant, upon purchase, to the labouring inhabitants life-annuities, to be paid out of the parish rates. The measure met with support from some of the most distinguished characters of the time, and a bill was brought into the House of Commons by Mr Dowdswell, under the auspices of Mr Burke, Sir G. Savile, Lord John Cavendish, Mr Dunning, Mr Thomas Townshend, and others, for carrying it into effect. The plan received the sanction of the Commons, the bill was passed, and carried to the House of Lords. Here it was not equally fortunate; it was not even permitted to come to a second reading. One cannot conceive any very good reason for throwing it out; because, if it produced any effects, they could not be evil. The defect of the project appears to consist in this, that it was not calculated to produce effects at all; it involved in itself an obstruction fatal to its operations. To purchase these annuities a sum of money, large to the purchaser, was demanded all at once. How was he to possess it? Whence was he to obtain it? The means were almost universally wanting, and likely to continue so.

It is worth while to mention, that a savings bank, entitled *Le Bureau d'Economie*, was established by law at Paris, in one of the first years of the French revolution, and it was in existence till a late period, perhaps is to the present. The account of it which we have seen, is in the *Archives of Useful Knowledge*, published in Philadelphia, where a bank of industry was lately established. Mr Bentham's plan of a frugality bank, added to this scheme two important amendments, which at once brought it within the range of practicability, and enlarged the bounds of its usefulness. He proposed that the people should purchase life-annuities, by sums deposited

gradually; and that these annuities should be convertible into other forms of benefit, suitable to the exigencies of each individual.

With regard to the best model of a savings bank, there is nothing of much importance which remains to be said. The great difficulty consisted in the original idea. When that was fully framed, every thing else suggested itself, without the smallest difficulty. Two things were immediately seen to be fundamental: In the first place, security for the funds: In the second place, the zeal of the people. The best general instruction which can be given to those who have institutions to form, is to set these two objects before them, as the ends which they have to pursue; and to adopt the means, which, in the peculiar circumstances of each case, promise to be most effectual in attaining them. 1. With regard to security, the course appears to be abundantly plain. There is perfect security with many other advantages in the great banks in Scotland, which of course should be universally employed. In England, there is no resource but government security, to which, as at present existing, several inconveniences are attached. 2. With regard to the excitation of that degree of fervent interest among the people, which is necessary for the production of any considerable effects, all persons will not have their minds equally open to conviction. Yet the means appear to be abundantly certain and clear; let the contributors, in annual meetings, choose their own office-bearers, not limiting the choice to their own body; and let the people of weight and character in the district, not only show their readiness, but their desire to be chosen. This is the general idea; it may be modified into a variety of forms, according to the circumstances of different places; circumstances to which matters of detail ought as much as possible to conform. It is an appendage to this principle, that the numbers, hence the district, should not be large, which a single bank is destined to serve. This appears to be expedient, or rather indispensable, on other accounts; to facilitate access to the customer; to prevent loss of time by attendance, if numbers should be liable to repair to the same office at the same time; and to render practicable, by division, the otherwise impracticable amount of labour, which, if the great majority of the people should bring deposits, the management of them will create. (FF.)

Banks for Savings
||
Bannockburn.

General Rules for the formation of these Banks.

BANNOCKBURN, a rivulet in the county of Stirling, celebrated for a battle fought on its banks in the earlier part of the fourteenth century. As no correct details of this battle have been given in the body of the work, it becomes necessary to supply that defect in this place.

The failure of the royal line of Scotland, by direct descent, in the grand-daughter of Alexander III. who died in the year 1290, excited a competition among several powerful nobles for the crown. But deciding their respective rights by the sword would have deluged the kingdom with blood; nor were the finances of any in that condition which could enable them to maintain an arduous and protracted contest. The claims of all were, therefore, by common consent, sub-

mitted to Edward I. of England, a warlike and politic prince, who, having heard them patiently, with due solemnity adjudged the throne to John Baliol. Edward, though without apparent partiality, had not lost sight of his own interest; but the truth was soon betrayed, that he wished to render Scotland an appanage of England, could it have been effected. The right of superiority was asserted, acknowledged, and then resisted; but Edward had power in his hands, and the abdication of Baliol followed a short and troubled reign. That monarch now openly avowed his design of subjugating Scotland, which he affected to consider only as a fief of his kingdom. Some patriots arose in the course of an interregnum; but their co-operation being generally disturbed by jealousies among

Bannock-
burn.

themselves, they were quickly overwhelmed, and a large proportion of the peers and barons swore fealty to the English sovereign. By a barbarous sentence, the most distinguished defender of Scottish liberty, Sir William Wallace, was put to death at London, and Edward conceived that the terror of his punishment would restrain others from resistance. He was mistaken, however, for Robert Bruce, Earl of Carrick, grandson of one of the original competitors for the kingdom, reviving his claim, was crowned at Scone in the year 1306, and prepared to vindicate it by the sword. He was at first unsuccessful, and two of his brothers perished in the contest, while the English were repeatedly victorious, and obtained possession of all the strong-holds throughout the country. Meantime, after expressing irreconcilable hatred to Bruce, Edward died, and his son, who solemnly swore that he never would remain two nights in the same place until he reached Scotland, resolved to maintain his superiority. But the imbecility which he speedily displayed, his ignorance of the real dispositions of the people with whom he had to deal, and other circumstances, induced many who had pledged their fealty to his father now to desert himself; and the partizans of Bruce, who was generally acknowledged the real and legitimate sovereign, rapidly increased in number. The south and west were released from the power of the English; several places of strength were gained, either by force or stratagem; and, encouraged by success, he even ventured to penetrate the less protected parts of the neighbouring kingdom. Edward, however, sought to preserve the allegiance of those who still adhered to his interest, by conferring obligations upon them; and as there were many in Scotland disaffected to the government of Bruce, he never abandoned the original plan of subjugation. After various successes and discomfitures on either side, one of the strongest fortresses, Stirling Castle, then in possession of the English, was invested by Edward Bruce, a surviving brother of the king. The governor, Sir Philip Mowbray, pressed on all hands, offered to surrender if he should not be relieved by his countrymen on the 24th of June 1314, to which Bruce, commanding the besiegers, incautiously assented; and although he thus incurred the displeasure of his brother, the sanction of the latter was not withheld. It was these preliminary events, which we deem it necessary to explain, that were productive of the celebrated battle of Bannockburn.

Edward being made acquainted with the circumstances, quickly ascertained the importance of carrying succours to Stirling Castle, and resolved to levy a powerful force for the purpose of combating the Scottish king, who was posted so as to intercept his access to it. From the writ commanding the different counties to furnish their respective proportions of the military, it would appear either that the design of Robert to dislodge his enemies was long premeditated, or that he had remained a considerable time encamped at the place of rendezvous, the Torwood, a few miles east of Stirling. It specifies that "the Scots had endeavoured, as far as they were able, to collect a vast body of foot in a strong and rugged position, where it was difficult for cavalry to act, between him and his

castle of Stirling." Probably the Torwood then extended farther west than we are accustomed to fix its limits at the present day; therefore we must seek for the Scottish camp nearer the object of contention. There were assembled about 30,000 men, besides an unarmed and undisciplined rabble of followers and retainers, amounting to a great number, not less than perhaps two-thirds of the regular force. The Scottish historians calculate the English army at 100,000 men.

But here we cannot sufficiently regret that it is principally from a poetical narrative and tradition we are enabled to deduce the interesting events of that æra; therefore, as poets are in general but faithless historians, their writings must always be received with reserve. At the same time, Barbour, the poet who records the battle of Bannockburn in detail, seems to have had little in view, besides the glory of his country; and there are also some slight notices to be found elsewhere corroborative of the general train of the history.

On Saturday the 22d of June, Robert having received intelligence that the English had reached Edinburgh, withdrew his army from its encampment in the Torwood, to take up another position in the neighbourhood of Stirling Castle. There he extended his troops in three divisions, occupying a wood, it would appear, from the stream called Bannock, on the right towards the church of St Ninian, and on the left nearly, it is supposed, in the direction of the present road from Edinburgh to Stirling. In the night he directed a great number of small pits to be dug knee-deep, and covered with turf, concealing at the bottom a kind of projecting spikes called calthrops, or caltrops, designed for the destruction of cavalry. The position was besides protected by a morass in the vicinity, and peculiarly favourable, in many respects, against the attack of cavalry, which the Scottish king chiefly dreaded. On Sunday the 23d, an alarm spread of the approach of the enemy, and Bruce prepared to receive them, for he had now chosen the ground on which he awaited the attack; his whole army heard mass, and in answer to his proclaiming that those who were not confident of victory might retire, all unanimously declared their resolution to conquer or die. His troops were marshalled in three divisions, of which that on the right was commanded by his brother Edward, the left wing by Lord Douglas and the young Stewart of Scotland, and the centre by his nephew, Randolph, Earl of Murray, while he himself took the command of the reserve, posted on a rising ground in the rear, whence he could obtain a view of the passing incidents. But it is remarkable that this reserve consisted of the most savage part of the inhabitants of Scotland, the Western Islanders and men of Argyle, as also his own vassals of Carrick in Ayrshire. The followers of the camp were now sent to a valley at a little distance to the left of the position. In this manner Bruce designed to deceive his enemies.

Meantime a squadron of 800 horse was detached from the English army for the purpose of gaining Stirling Castle, by a circuitous route through the low ground to the north-east. The king, the first to perceive it, reproached the Earl of Murray, his nephew, with leaving the place exposed, and he,

Bannock-
burn.

Bannock-
burn.

anxious to repair his fault, hastened with 500 spearmen to check the enemy, wherein he with difficulty succeeded. Soon after, the van of the English appeared in sight, while Robert was in front of the Scottish line. He was recognised by Henry de Bohun advancing a bow-shot before his comrades, from a crown surmounting his helmet, and the authoritative manner in which he disposed his troops. Being mounted on a sorry horse, the Englishman quickly advanced upon him, but his spear missing the king in his course, the latter, rising in his stirrups, cleft his helmet with a single blow of his battle-axe, and Bohun fell to the earth. This valiant deed encouraged his people; but to his friends, who warned him he had exposed himself too hardily to danger, he tacitly seemed conscious of temerity, and regretted that the shaft of his weapon had been broken by the violence of the blow. This closed the operations of the first day.

The armies reposed in the vicinity of each other; both were impatient for the succeeding dawn, the one anticipating undoubted victory, the other in anxious hopes of being liberated from the yoke of strangers. Bruce addressed his troops, recapitulating the conduct of the enemy, how the government of the country had been usurped, and those that had fallen into their hands most barbarously treated; that now they were to fight for all they held dear, their own personal liberty and the safety of their families. He showed them, that their position was such as would insure success; that they fought in a good cause, but the English only for conquest; that they would, when victorious, be enriched with the spoils of the vanquished, and he promised that the heirs of those who fell should enjoy privileges merited by the conduct of their predecessors. But he strenuously urged the necessity for order, to avoid pillaging the slain, and to preserve their line unbroken.

At break of day, the Scots, drawn out in battle array, beheld the English already prepared; but, notwithstanding their own inferiority of number, they were animated by the justice of their cause, and with confidence in their leader. To propitiate the Deity, Maurice, Abbot of Inchaffray, celebrated mass, and passed in front of the army, bearing a crucifix in his hand, and exhorting the soldiers. The troops then partook of some refreshment, and Bruce, in conformity with the customs of his æra, created some of his most distinguished followers knights.

The English army was commanded by Edward in person, attended by a body guard of 500 cavalry well armed; and among his troops were 52,000 archers. But the same unanimity did not subsist as among his foes; although he, on his part, was confident of victory; and the Scottish host having knelt with one accord to utter a pious ejaculation, and receive benediction, he exclaimed to those around him, "Behold, they kneel to ask mercy!" He was quickly undeceived.

A signal was now given; the armies approached, and a sanguinary contest ensued, unexampled in the annals of British history. The van of the English, composed of cavalry, galloped on to charge the right wing of the Scots, commanded by Edward Bruce, which received them with intrepidity. While this wing was en-

Bannock-
burn.

gaged, Randolph advanced with a division to meet the main body of the enemy; and the left wing also hastened to participate in the conflict. Repeated charges of cavalry attempted, but in vain, to break the Scottish line; it proved impenetrable; they were everywhere resisted and repulsed. At this time, the battle seems to have been general, but the Scots were drawn up in a small and compact form, while the unwieldy mass of the English army could only be partially brought into action. Nevertheless, the former were grievously annoyed by the archers; but they fought desperately with their spears, swords, and knives, and also iron clubs or maces; besides, they were protected by light armour, which did not restrain their agility. Edward, the king's brother, was hard pressed by the English cavalry, and the Earl of Murray, making a movement to his support, was almost overwhelmed by the multitude of the enemy, while a terrible shower of arrows saluted the third division advancing to their relief, which galled them severely. The English still presented a vast and extensive front, but the king directed one of his chosen leaders, Sir Robert Keith, to take the archers in flank with 500 horse, and their impetuosity proved irresistible. They were suddenly overthrown, and fled with precipitation. The king, satisfied with this important advantage, brought up the reserve, encouraging his people to press onward, as they were now sure of victory; and he spoke with greater confidence, as the Earl of Gloucester, in endeavouring to rally the fugitives, was unhorsed and slain. The reserve about this period fell into the line, which had been weakened in no inconsiderable degree by the previous operations: the Scottish archers, in their turn, did uncommon execution among the enemy; they inspirited each other to the attack, and their comrades bore every thing down before them. The numbers of the English proved their own destruction: for those who recoiled, threw the rest into disorder, and those who fell were immediately trampled to death and destroyed. Notwithstanding, the battle continued to rage furiously, and victory was long and keenly contested. But, at length, at this critical period, the retainers of the Scottish camp, who had previously been sent to a valley in the rear, suddenly appeared on the neighbouring height in view of the English army. Intimidated by the approach of what was believed a strong reinforcement, they soon began to waver, and as Robert urged his troops forward, they gradually receded, and at last took to flight. Edward, with 500 horse, prepared to seek shelter in Stirling Castle, but the governor found means to dissuade him from it; and he then consulted the speediest means of escape. The rout of his army became complete, their bands were totally broken, and they fled with precipitation on every side. Some sought refuge among the rocks of the castle; many hurried to the river Forth, where they were drowned; but the most terrific scene of carnage was in the valley where the rivulet Bannock flows; for the ascent towards the east being steep and difficult, and then probably impeded by wood, they were exposed to inevitable destruction. Scarce any who took that direction escaped; the course of the stream was interrupted, and a bridge was formed of the bodies of

Bannock-
burn
Barbary
States.

the slain. The peasantry, witnessing the defeat of the English soldiers, inhumanly slaughtered them, gratifying their revenge, and glutting themselves in blood. Nevertheless, prodigies of valour were performed; and, at the earlier part of the rout, Sir Giles Argentine telling Edward it was not his custom to retreat, rushed amidst his enemies and was slain. But Edward, hotly pursued, continued his flight, followed by 60 horse under command of Douglas, until both, as if by mutual consent, halted at Winchburgh, 20 miles from the field of battle. Again mounting, the pursuit was continued 40 miles farther to Dunbar, where the castle gates being opened to Edward, a vessel conveyed him to England.

Meantime, the scattered fugitives were either falling under the sword of their enemies, or seeking safety in the speed of their flight. A body of Welshmen appeared nearly naked, having been induced to throw aside their upper garments, in order to fight with the greater freedom; and now were the easiest victims. Some continued to conceal themselves in the woody parts of the neighbourhood in hopes of mercy; and Sir Marmaduke Twenge, after lurking through the night in a bush, surrendered himself to Robert, personally, by whom he was courteously treated.

There are two things which it is equally difficult to ascertain, the numbers who fell, and the duration of the engagement. The victors are always prone to magnify their conquest; the vanquished to diminish their defeat, and to exaggerate its difficulty. If it be true that Edward fled on the same day to Dunbar, the conflict, though from dawn, could not be very long; yet, it is not easy to conceive how the unwieldy mass of the English army could be brought into action unless by slow operations. The loss on both sides was certainly very great. Barbour asserts that of the English to have been 30,000 men, and that 200 knights were killed. But the truth of this calculation is disputable, especially as it is said elsewhere, that only 42 knights were slain, and 60 made prisoners. Barbour also affirms, that only two Scotsmen of note fell on the occasion, Sir William Vipont and Sir Walter Ross. The king bitterly regretted the Earl of Gloucester, for he was his own near relative, and historians maintain, that had the Scots known him he would not have fallen that day. He caused his body to be carried to St Ninian's church, and watched

all night, and then sent with that of Lord Clifford to England. The more distinguished slain received interment in consecrated ground, the others were thrown into pits. The booty taken in the battle was immense; so great, indeed, as to disseminate riches throughout the kingdom, which may well be believed, as the English anticipated nothing less than discomfiture. "O day of vengeance and fatality," one of their historians exclaims, "hateful accursed day, to be blotted from the circle of the year; a day which tarnished the glory of England, despoiled our nation, and enriched its enemies to the amount of L.200,000. How many valiant youths and illustrious nobles, how many excellent horses and beautiful arms, how many precious vestments and golden vessels, were lost in that single unfortunate day!" The privy-seal of Edward was also among the spoils, but restored by Robert, who used his victory with such clemency and moderation, as to gain the applauses even of the hostile nation. Among the prisoners was Baston, a Carmelite friar, said to have been brought by Edward to celebrate his expected conquest; he now obtained his freedom on condition of paying a similar ransom, but in favour of his enemies. His poem probably merits more attention and confidence than ought to be bestowed on any other narrative of the battle, because he alone was contemporary with it, and most probably was a spectator of many of the incidents which happened twenty years before Barbour was born. But we must again regret that it fell to the share of poets only to perpetuate the remembrance of events so important and interesting.

The immediate consequences of this great victory were the surrender of all the fortresses of Scotland to their lawful owners, the liberation of the inhabitants from a foreign yoke, and the firm establishment of the sovereign on the throne. Many inconsiderable engagements have been magnified into battles, but this may probably vie with those most celebrated in history, though fought at a period when the nation was, without all doubt, almost in a savage state. Some memorials of it still remain on the spot; armour and weapons have been frequently dug up from the neighbourhood; and at an interval of 500 years, the inhabitants of the vicinity met on the 24th of June 1814, to celebrate the triumph of their ancestors, the memory of which has been sedulously preserved among them. (s.)

BARBARY STATES.

THE name of Barbary, or the Barbary States, is applied by the moderns to an extensive district, occupying, with the exclusion of Egypt, the whole northern coast of Africa. It comprehends also that portion of the western coast which lies to the north of the Great Desert. The States included within this district are entirely independent of, and even hostile to each other; and they also differ in some particulars of their political constitution. There prevails, however, a striking similarity in the whole of their moral and physical circumstances. Throughout

all these states, we see the same races inhabiting the towns, the plains, and the mountain districts; the same forms of social life; the same degraded and corrupted barbarism succeeding to ancient grandeur and civilization. Nature presents a corresponding similarity in all the peculiar qualities of aspect, soil, and climate. These resembling features constitute Barbary decidedly one region; and it will, therefore, be convenient to include its various states in one general article.

In the body of the work will be found, under the

Barbary States.

Barbary States.

head of BARBARY, and under those of MOROCCO, ALGIERS, TUNIS, and TRIPOLI, a pretty copious account of the history of these states, and an outline of their peculiar constitution. It remains to give a general view of the physical aspect of this extensive region, of the various classes of its inhabitants, and of its present political and social condition.

Physical Aspect of Barbary.

Among the natural objects which this region presents, the most prominent is that immense and celebrated mountain chain which, under the name of Atlas, traverses nearly its whole extent. The loftiest portion is that which towers over the plain of Morocco, which, notwithstanding the intense heat of the climate, presents a range of summits clad in perpetual snow. The most recent traveller in this country, known by the name of Ali Bey, states that, after a very careful measurement, he found this portion to be 13,200 feet above the level of the sea. The lower stages are well cultivated, and of luxuriant fertility; while, in ascending, they exhibit every variety of climate, from the torrid to that of the frigid zone. In skirting the kingdoms of Algiers and Tunis, its height is greatly diminished, and is represented by Dr Shaw as not exceeding the loftier eminences of our own island. The greater part of its declivity is here covered with vines and forests; and only occasionally a rocky precipice rears its head above the rest. This part of the range separates into various branches, bearing different names. The most elevated is Mount Jurjura, in the province of Algiers, which is covered with snow during a great part of the year. It forms a species of chain by itself, and rises very high above all others east of Morocco. Besides the grand chain, there is found, between it and the sea, another, called the Little Atlas, extending from the Straits of Gibraltar to Bona in Algiers.

The structure and component parts of this vast range have been very imperfectly explored. It appears probable, however, that, as in other mountain groups of the first magnitude, the central mass, as well as the loftier pinnacles, are composed of granite. Ali Bey states, that the rocks on the coast consist of secondary granite, with sandstone resting on it; a combination which seems deserving of notice, from its resemblance to that which occurs at the southern extremity of Africa. Marble also is said to occur abundantly in the western regions. The lower and eastern branches appear, however, to contain a large proportion of calcareous rocks. The chain, considering its extent, is thought not peculiarly rich in metallic ores, though this character may have been derived from the supine neglect of the inhabitants in exploring its mineral treasures. Silver and copper are procured to a considerable amount in the Tunisian territory. Algiers has lead, and a small proportion of iron. Morocco contains no mines that are known or worked, unless in the province of Suse, the southern extremity of the empire. There, iron is found at Idaultit, and copper, in considerable quantity, in the vicinity of Tessellert. The report of gold and silver mines is treated as a fable by Chenier; but Jackson asserts that he saw evident traces of them in the neighbourhood of Measa. He confirms the report of Leo, that the

sovereigns of Morocco discourage the working of these mines, lest the natives, who at present can with difficulty be retained under the yoke, should thus be enabled to set them completely at defiance.

That narrow tract between the Atlas chain and the sea, which comprises the Barbary States, forms a plain of luxuriant fertility, traversed by innumerable streams, descending from this mighty storehouse of waters. Chenier calculates, that upwards of six thousand are poured down from the western Atlas upon the plains of Morocco. The vicinity, however, of the receptacle to their source, prevents their ever forming rivers of great magnitude. The principal are, in Morocco, the Seboo, the Morbeya, the Tensiff, and the Suse; in Algiers, the Shelliff; in Tunis, the Mejerdah. The soil, which is naturally of the same loose and sandy character which prevails over northern Africa, is, by this profusion of moisture, rendered equal in fertility to any in the world. Its lightness is even beneficial, by enabling it to be worked with the utmost facility, so that, according to Dr Shaw, a yoke of oxen can plough an acre in the day. But wherever water fails, deserts are produced, which present, on a smaller scale, the same appearances with those immense wastes which extend south of the Atlas. The moisture then, which these mountains supply, is the sole spring of fertility to northern Africa; and Tripoli, where they terminate, borders almost immediately on the sandy waste.

Along the southern base of the Atlas extends a vast region, called Biledulgerid, or more properly Bled-el-Jereede—the dry country. It forms a gradual transition from the luxuriant plains of Barbary to the sterile desolation of the Sahara. Large streams, descending from the great chain, traverse it from north to south, till they expand into lakes, or are lost in the sands of the desert. The moisture, evaporated by the scorching winds which blow from the south, is not sufficient for the production of wheat, barley, or the finer fruits; dates are its abundant and almost sole product. They form the food of its inhabitants, and the basis of their commerce. Considered in a political view, this region is nominally subject to those states of Barbary which lie in contact with it; but the subjection scarcely amounts to more than the payment of a certain tribute. The part contiguous to, and dependent upon Morocco, is known by the names of Taflet and Sigilmessa.

The whole of Barbary abounds, in a very remarkable degree, with different species of saline substances. Common salt particularly is found in every form, and in the greatest abundance. That drawn from the mines of Morocco is of a red colour, very strong and coarse; a white and finer kind is produced by evaporation on the sea coast. The lakes of Barbary are almost all salt, to an equal degree with the sea itself; and in the course of the summer, many of these dry up entirely, leaving the mineral encrusted on their beds. Near the lake of Marks, in the Algerine territory, there is a mountain composed entirely of salt, and all the chains which traverse it contain copious repositories of this mineral. Most of the springs which are not warm are salt; and in the territory of Tunis, there is no fresh water, unless from rain. Many of the rivers, when

Barbary States.

they dry up in summer, leave their banks copiously encrusted with nitrous and saline exudations. Saltpetre is not found in a concreté state; but at Tlemsan, Kairwan, and many other places, the earth is so impregnated with it, that six ounces are obtained from a quintal of soil.

The Atlas mountains, so far as hitherto known, are not the seat of any volcanic eruptions. In East Barbary, earthquakes are frequent during the hot and dry season; they have sometimes thrown down houses, and even carried them to a considerable distance; but these are rare instances; for their effects are by no means so great and terrible as in the south of Europe, and other countries exposed to their ravages. The interior heat, however, manifests itself by that which it communicates to a large proportion of the waters, which flow through this territory. Most of the streams of the Jereede are at least lukewarm; and near Oran, Tlemsan, Gabs, and other places in the territory of Algiers, they acquire a temperature which fits them for warm baths. About 40 miles to the east of Constantina, are those called the Hammam Meskouteen, the heat of which is so intense, as to boil animal food in a quarter of an hour. The rocks over which this rivulet flows are entirely calcined by its influence, which, acting variously on the different substances, consuming some and leaving others nearly entire, produces some curious phenomena. The rocks at one place represent a line of regular cones, believed by the Arabs to be the tents of their ancestors converted into stone. At another placé, the action is still deeper and more irregular; the figures of sheep, horses, camels, even of men, women, and children, are presented to the eye, all of which are believed by the natives to have undergone the same transformation.

Vegetable and Animal Productions.

The productions of the soil in Barbary are not materially different from those of southern Europe, the climate being brought, by the vicinity of the mountains, to pretty nearly the same temperature. The grains chiefly cultivated are wheat and barley; of which the crops are abundant, though there is not above one in the year. Oats are not frequent, but beans and lentils are very common. Pease have been introduced by Europeans. Pot herbs and fruits are abundant, and nearly resemble those of Europe, with addition, in the last branch, of the palm tree and the lotus.

The animal world, particularly in its wild members, presents an interesting field of observation. The Numidian lion still retains its ancient character of strength and ferocity. To guard against its attacks, the villages and encampments are surrounded with a species of palisade, and upon the slightest alarm, large fires are kindled; yet these multiplied precautions are not always sufficient to prevent the irruption of this lord of the forests. The animal called here a tiger is in reality only a panther. Wild boars are very numerous, and the hunting of them affords a favourite amusement. The hyæna is common, and is called the *dubbah*. Jackson mentions an animal, called the *aondad*, which inhabits the most lofty and precipitous regions of the Atlas; but, on account of its rugged and inaccessible haunts,

has never been sufficiently observed or described. The antelope, or gazel, from its beauty, is the favourite of the Arabs. The Barbary females paint their eyes with a preparation of lead called Elkahol-fillely, in order that they may rival the largeness and blackness of those of the gazel. Gazel here, as angel with us, is the most flattering epithet that can be applied to female beauty. Although the antelope be the swiftest of all animals, he is soon fatigued, so that the greyhound at length comes up with him. The flesh is valued, and is similar to venison. Among the smaller animals, the most noted are the jerboa and jird, which are about the size of a rat, burrow in the ground, and afford agreeable food.

Barbary States.

Among birds, the chief is the ostrich, an often described species, and which occurs along the whole northern border of the desert. Those about Wadinoon and Cape Bojador are said to be the largest, and to have the finest feathers of any in the world. The feathers form a considerable article in the commerce of Morocco.

Birds.

The serpent species is very numerous. The great Boa Constrictor is frequently found in the Sahara. It is not poisonous, and destroys merely by its immense strength and ferocity. There are several species, which contain a very active poison; but these, Dr Shaw conceives, do not exist in that great variety which is enumerated by ancient writers. There are also domestic serpents, which are of a more harmless nature, are never molested, and held even in a kind of veneration. The most destructive of this class are the scorpions, which swarm to such a degree, that, in summer, they are often found in the beds. It is believed in Morocco, that the flesh of this animal affords a cure for its bite; and most of the inhabitants, on that account, keep a bottle of scorpions preserved in olive oil. Shaw observes, that those of Algiers and Tunis, to the north of the Atlas, are not very noxious, causing only a slight inflammation and fever, but that, in the Sahara, they are much larger, and their venom more malignant.

Serpents.

The insect tribe, in this country, presents a much more terrible enemy, the locust. This destructive insect is bred on the confines of the desert; but at irregular intervals, impelled by some unknown cause, its swarms take their direction towards the cultivated regions. They move in vast bodies, and with an order which resembles that of regular armies. The march is all in one direction, led by a chief, called by the natives Sultan Jeraad. All attempts to stop their course by digging deep pits, or by kindling fires, have proved abortive. The foremost, indeed, fall victims to these means of annoyance; but the vast mass behind, undismayed by the fate of their forerunners, continue to pour on, file after file, in close and uninterrupted succession. The fires are extinguished; the pits are filled up; and the husbandman abandons in despair every attempt to arrest their progress. Every thing green is thoroughly consumed; and the fields, from being clad in all the verdure of spring, assume at once the aspect of wintry desolation. This scourge sometimes continues for several years, and is not unfrequently followed by the still more terrible evil of plague. It forms a very inconsiderable compensa-

Insects.

Barbary States.

tion to the inhabitants, that they use the locusts as food, and, in that view, regard them even as a delicacy.

Domestic Animals.

The domestic animals do not differ materially from those of Europe, with the exception of the camel, which, though frequent in Barbary, belongs more properly to the desert. The excellence of the horse was formerly the boast of Numidia; and Barbary horses have been highly valued, even in modern times. But the breed is said to have degenerated, chiefly in consequence of the best horses being liable to be seized by persons in power. The ass, and still more the mule, are the animals chiefly employed in labour. The cows are small, and produce little milk. The sheep fed on the Atlas are often of exquisite flavour. The wool being left entirely to nature, is of various quality, some of it coarse, but some very fine. The goats of Morocco produce that species of leather, the softness and pliability of which make it to be held in such high estimation.

Remains of ancient Art.

After surveying the aspect of nature, our attention is next drawn to the ruins of ancient art. The whole extent of Algiers and Tunis, and even deep into the desert, is covered with the most superb monuments of Roman grandeur. Constantina (the ancient Cirta), Spaitla (Suffetula), El Gemme, and many other places, exhibit specimens of the architecture of that people in its highest perfection. The temple at Spaitla is considered by Bruce as the most perfect example of the composite order existing. It seems matter of regret, as well as of surprise, considering the general interest taken in these objects, that the drawings made by Bruce, or, under his direction, said to be very fine, should never have been given to the public. The remains of Carthage are entirely subterraneous; yet these still convey an idea of the greatness and industry of that celebrated people. Of that immense aqueduct which conveyed water to the city from the distance of sixty miles, many hundred arches are still to be seen, and several cisterns, nearly entire, are used as habitations by the Arabs. A few years ago, in digging among the ruins of Utica, some labourers found a number of beautiful statues, some mutilated, but others in complete preservation. Among them were two statues of Tiberius and Augustus, the former very finely executed, and four female figures, two of them exquisite specimens of Grecian sculpture. The spirit of antiquarian research seems to be active among the Christian inhabitants of Tunis; and many, even of the poorer classes, are said to be in possession of medals, engraved stones, and other curiosities. These, however, by being dispersed, are in some measure lost to the public. M. Fagan, the British consul at Palermo, lately applied for permission to make excavations, which would no doubt be obtained, provided an adequate pecuniary compensation were offered. In that case, very interesting discoveries would probably be made.

Different Classes of Inhabitants.

The population of the Barbary States is made up of a number of distinct races. A particular survey of each will therefore be necessary, in order to afford any complete view of the subject.

The first and most numerous class are the Moors. This is an European term, derived from the ancient *Mauri*, of whom probably no traces are now to be

Barbary States.

found. It is applied to the inhabitants of the cities of Barbary, and the country in their immediate vicinity. Their manners and habits of life have been described in considerable detail in the body of the work, under the head of Morocco. Generally speaking, a Mahometan city presents an uniform aspect. Everywhere the same silence and seclusion, the same absence of all gaiety, bustle, and animation; narrow and dirty streets, bordered on each side by lines of dead wall,—each individual burying himself in the interior of his family, and shrouding his existence, as it were, from every other eye; while the female sex, who, in Europe, form the ornament of society, are immured in the apartments of the haram, bought and sold almost as slaves. With all this is combined an outward deportment of great gravity, solemnity, and decorum, with which neither the sentiments nor actions are found to correspond. All this is more particularly true of the cities of Morocco; for in Algiers and Tunis, an unsettled government, and the habits of a seafaring life, have produced, especially in the lower orders, a greater appearance of activity and turbulence, though without any departure from the general tenor of oriental habits.

The *Letters* lately published, written by a female relation of Mr Tully, formerly consul at Tripoli, give a very lively picture of the manners of a Barbary court, and particularly of female society. This she had very peculiar access to observe, through the intimate footing on which she lived with the ladies of the palace. The wives of the bashaw, and the other grandes, are generally Georgian or Circassian captives, who are purchased at Constantinople at an early age, and trained in all those accomplishments which fit them for the harems of the great. By the Mahometan law, each individual may have four wives, and an equal number of concubines; but there is one principal wife, who alone shares the sovereign power. She has usually the same origin with the others, and enters the haram as a slave, but succeeds, by address and superior powers of captivation, in raising herself to this envied dignity. It is unlawful for the daughters of the sovereign to marry a subject; and as they do not usually form alliances with foreign states, they have no resource but to marry Turks and renegadoes, the refuse of the society. They thus often choose as companions for life, persons unworthy even to appear in their company. Accordingly, the husband is ruled with the most absolute sway, and treated usually worse than their slaves; to all which he quietly submits, in consideration of the lucrative offices to which this connection secures his advancement.

The toilet of a Moorish lady is said to be formed entirely after the ancient model. No dressing-table is used; but a number of slaves attend, to each of whom a different office is assigned. One plaits and perfumes the hair, another arranges the eyebrows, a third paints them, and so on. A profusion of the richest Arabian perfumes and scented waters is used, and powdered cloves, in vast quantity, are stuffed into the hair. The eyelashes are, by a very tedious process, painted black, and, by pulling out a number of the hairs, are formed into a particular shape. This operation, though attended with very

Barbary States.

acute pain, is cheerfully submitted to. In short, a Moorish lady cannot be fully dressed under several hours; and her appearance is then so completely altered, that her nearest relations could scarcely be able to recognise her.

These ladies are represented, in the letters alluded to, as by no means spending their time, as usually supposed, in listless indolence. It is their task to overlook the numerous slaves who grind, spin, and perform all the necessary domestic offices. They are particularly expected to superintend the culinary operations; in order to guard against poison, the administering of which at meals is not unusual in these countries. These cares, with those of their family, fill up the time of the more amiable and domestic members of the haram; while those of a lighter turn find full occupation in the difficult and dangerous intrigues to which their disposition prompts them. With a few exceptions, however, they seem tolerably cheerful; and the view which these letters give of their character is, on the whole, favourable.

The inhabitants of the towns do not form a race by themselves, but are aggregated from the various races who inhabit, or have inhabited, the country districts—the Arabs, the Brebers, probably in part also the ancient possessors, and the Vandal conquerors of northern Africa. All these have been cast into that mould which Moslem despotism invariably forms. There is, however, a peculiar race, called Andalousie, descendants of those Moors, expelled from Spain by the stupid despotism of that government. They inhabit chiefly the northern cities of the empire of Morocco. They pique themselves on their descent, and seem to retain somewhat of that pride of birth which was probably formed during their residence in Europe.

The sciences, which anciently formed the glory of the Saracen name, are now, throughout the whole of this region, entirely extinct. Instruments are still shown, which display the most exquisite mechanical skill; but they are preserved merely as antique curiosities, without any knowledge of the principles by which they were constructed. Astronomy does not extend to the construction of a sun-dial, nor chemistry beyond the making of rose-water. With regard to medicine, the estimation in which that science, once so flourishing, is held, may be judged by the emolument reaped by its professors. The fee of a physician scarcely ever exceeds sixpence; and the most serious operations are performed for a shilling. These humble practitioners succeed tolerably, when only external wounds are to be healed; but in all internal maladies, it appears very doubtful whether most patients die of the disease, or of the remedies administered.

The Jews form a numerous class throughout all the cities, both of Eastern and Western Barbary. They seem to exist there nearly on the same footing as in Europe during the middle ages, the objects of universal hatred, contempt, and derision, and their plunder the invariable resource, whenever the sovereign finds himself in pecuniary embarrassment. Yet their knowledge of trade, and entire devotion to it, have almost secured to them the monopoly of mercantile and money transactions; and they are thus enabled to make such enormous profits as induces

them to endure all this oppression. In Morocco, however, long suffering appears at length to have wearied their patience, and their numbers have been considerably thinned. In the capital, they are not now supposed to exceed 2000. No such diminution seems to have occurred in the other states. Tunis is calculated to contain above 15,000.

The country Moors, or those who cultivate the plains of Barbary, appear to differ very widely from the inhabitants of the cities. The property, or rather the occupation of land, is, as usual in despotic countries, much subdivided. The manners of the cultivators have been little observed, but they are said to be characterized by a peculiar degree of ignorance and simplicity.

The inhabitants of the pastoral districts intermediate between the sea coast and the Sahara, are known by the name of Arabs. They appear, in fact, to comprise such of the descendants of the conquerors of Barbary as have adhered to their original and native employments. They exhibit the same migratory habits, the same simplicity of life, and the same union of hospitality and plunder, which distinguish their countrymen in Arabia. The touch of despotism has, however, taken from them much of that sense of honour and dignity which elevate the latter above the common level of barbarous tribes. They live in tents, thirty or forty of which united form a camp or *douar*, under the command of a shiek: the supremacy over a number of these camps constitutes a Great Shiek or Emir. The tents are made by themselves, of camels' hair and the fibres of the palm tree; they are arranged generally in three concentric circles, around the habitation of the shiek. The cattle go out to pasture during the day, and are tended by the men and boys; at night they are withdrawn within the circle of the tents. They are farther guarded by a number of vigilant dogs, who bark incessantly. The complexion of the Arabs is of a deep copper. The females possess beauty when young, but quickly lose it. They adorn themselves by puncturing and tattooing, practices unknown to the other inhabitants of Barbary. When the spot occupied by a *douar* is exhausted, they remove to another; the women are then conveyed in groups generally of three, upon the back of each camel; while the children, lambs, and kids, are lodged in panniers on each side. The shieks embrace every opportunity of acting independently; and whenever a weak government or civil war occurs, immediately begin to plunder. Of all the inhabitants of Barbary, the Arabs are animated with the most bigoted zeal for the Moslem tenets, and the deadliest enmity to the Christian name. This disposition, the effects of which have been felt by all European visitors, has probably darkened somewhat beyond reality the picture drawn by them of these tribes.

From the inhabitants of the plains, we ascend to those of the mountain districts. The greater part of the declivity of the Atlas chain is cultivated by a very remarkable people, called the Brebers. They have been named also Brebes, Berebbers, Barbars; and from them the name of Barbary is supposed to be derived. The Brebers appear to be descended from the original possessors of this region; they view

Barbary States.

Barbary States.

themselves still as its rightful owners, and regard with boundless indignation all the other nations by whom it is now occupied. Their subjection by always been very imperfect, and the slightest injury has been sufficient to drive them into rebellion. Their chiefs are elective, and they alone, in this part of Africa, have a government moulded into somewhat of a republican form. Their character is extremely warlike, and they excel the inhabitants of the plains in the management of fire-arms. The army of Morocco has often been completely defeated by them, and pursued to the gates of the capital. In general, however, they carry on war chiefly by surprise and ambush. The idea formed of them by the Saracen conquerors may be conceived by a passage in a celebrated Arabian writer (Bakoui), who gravely informs us, that they are the offspring of the giant Goliath, whom they resemble in strength and wickedness. They are divided into various tribes, of whom the Errifi, inhabiting a province of the same name between Algiers and Morocco, are the most powerful and ferocious.

The Brebers are distinguished from the other inhabitants of Barbary by a language which has nothing in common with any of the rest. It is considered by Adelung to be the same (allowing for some variation of dialect) with that of the Tibbo, the Tuarick, and of all the indigenous population of this part of Africa. Marsden and Langles have supposed it to be a corruption of the ancient Punic language; but Mr Pinkerton forcibly argues, that a language which has no abstract terms, none belonging to the arts and sciences, and no written characters, could scarcely be even a corruption of the language of a civilized people. Its high antiquity, however, cannot be doubted.

The Shellubs inhabit the southern parts of Morocco. They are smaller in stature than the Brebers, and in character somewhat less rude. In all other respects, they exactly resemble, and may be considered as a branch of that race. Some writers have asserted their language to be different; but the vocabulary given by Chenier, and the information of Dupuis, seem to leave no doubt that it is merely a dialect with very slight variations.

To these different classes we may finally add one which is not inconsiderable,—that of the negroes. Originally brought as slaves from Soudan and Tombuctoo, they have multiplied greatly, and have even risen to distinguished estimation. The sovereigns of Morocco, unable, from the natural jealousy of despotism, to trust their own subjects, have placed their entire confidence in negro troops. These form the standing army of the empire, the body guard of the sovereign, and the garrison of all the principal fortresses. Their pay is very small, not exceeding a penny a day; but its smallness is compensated by the licence in which they are allowed to indulge. A person, well acquainted with Morocco, being asked what their pay was, answered, "Whatever they can rob or steal." Muley Ishmael maintained nearly 100,000 of these troops. Their fidelity to their monarch is said to be exemplary. Negro slaves still continue to be imported in great numbers, particularly into Morocco.

Barbary States.

Political State of Barbary.

We proceed now to take a view of the political state of this extensive region, which has sustained no change from the lapse of time, and is that of a savage, uncontrolled, and turbulent despotism. In Turkey and the Asiatic empires, there are public bodies, rendered venerable by religion, by law, and even by knowledge, who share and moderate the power of the despot. In Barbary, there are none such; the will, or rather momentary caprice of the sovereign rules every thing. Yet the throne, though thus absolute, is not thereby rendered secure; resting on no basis, it is overturned by the slightest storm that arises. The death of a sovereign is almost invariably followed by disputed succession and civil war; so that tranquillity, the sole boast of despotism, is not even secured by it to this unfortunate country.

The present sovereign of Morocco is named Muley Soliman. He has three brothers, two of whom contended with him for the sovereignty, and being overcome, now live in exile. He is about forty, rather handsome, and of a quick comprehension. He is a *fakih* or doctor, deeply versed in the Mahometan faith, and passes the greater part of the day in prayer. His religious austerity prompts him to shun every appearance of luxury in his dress and manner of life. Requiring still greater simplicity in his ministers and attendants, he has completely banished that splendour which usually accompanies a court. The most pernicious effect of this bigotry consists in the hostility with which it inspires him against various branches of industry. He has ordered all the plantations of tobacco to be destroyed, because, although the prophet has not forbidden the use of that plant, there is no evidence of his having used it himself. In the same spirit, he opposes every possible obstruction to commerce with Europeans, whom, as infidels, he regards with horror. In other respects, his government is said to be milder than that usually experienced by the people of Morocco.

Morocco.

Algiers holds the next rank; but nearly a century has elapsed since any narrative of its internal state has been published by any European visitor. The most recent information regarding its interior that we have seen, is contained in an American publication, drawn up from the statements of the American captives who were confined there from 1793 to 1795. At that time the Dey was a Turkish soldier, named Hassan, about fifty, who had been brought from near Smyrna in the year 1786. Having insinuated himself into the favour of the reigning monarch, he gradually rose through the different offices to that of prime minister. The old Dey dying, Cedelli, a Greek, and a creature of Hassan, urged, and even ostensibly compelled him to assume the sovereignty. He prevailed; and another candidate who started up was put to death by the bow-string. There have probably been several changes since; and a new Dey is said to have come into power within the last six months. The Divan, it appears, have lost almost entirely the influence which they once possessed, and do little more than sanction the measures determined on by the Dey.

Algiers.

The present sovereign of Tunis is called Hamooda Bey, and is certainly an extraordinary character. He

Barbary
States.
Tunis.

has displayed a most energetic policy, and has seated himself more firmly on the throne than any of his predecessors. He is now (1816) about fifty-five years of age, and has reigned twenty-nine, a period quite unexampled in the tumultuous annals of Tunis. He has, in a great measure, thrown off that dependence on the Turkish power, by which the state was formerly enthralled; he even chooses his ministers and favourites, in preference, out of other nations. The mere vigour of his character and administration seems to have freed him from that dread of conspiracy and insurrection, by which former Beys were perpetually haunted. His brother, and his two cousins, though the rightful heirs to the throne, live on the most friendly terms with him, and partake of all his amusements. He extends a very liberal protection to all classes of his subjects, even Christians and Jews, who, before his time, might be insulted or killed with perfect impunity. He is indefatigable in the dispatch of business, and spends very little time in sleep, or in the haram. At seven in the morning, he generally receives the consuls of foreign nations in the hall of audience. From eight to twelve, he sits in the hall of justice. He is supreme judge throughout his own dominions; all his subjects, from the highest to the lowest, attend and plead their own cause. Unfortunately, wherever the Bey's personal interest is concerned, justice is entirely out of the question. His hand is always open for bribes from either party, and sometimes from both. Where such all-powerful motives do not interfere, he administers justice with equity, and even discovers a peculiar tact in eliciting the truth. His decisions are always given and executed with equal promptitude. Upon the whole, the security of person and property, and the general state of society, has been greatly ameliorated since his accession to power. Nothing seems to prevent him from being a good prince, except an avarice which knows no bounds, and hesitates at no means of gratification. This induces him to restrain the freedom of trade, to load it with monopolies, and often, which is worst of all, to become a merchant himself. He takes every opportunity of extorting money from his opulent subjects, without any pretence, and by the most arbitrary exactions. The following affords a curious example of Tunisian economy. He has erected a new palace, which will, it is said, be one of the most splendid edifices in Barbary; but, in order to lighten the expence, the ground floor has been fitted up into shops. He has given up the use of wine, in which he formerly indulged to great excess; but he is much addicted to other shameful species of debauchery.

The ministers and favourites of Hamooda are of the lowest description, both as to birth and character. The Zapatapa, or keeper of the seals, and Soliman Kiaya, commander of the army, are both Georgian slaves. The former is stained with every vice, but the latter exhibits an honourable and humane disposition, very rare in this country. The Bey's private secretary is a Christian slave; and the important and lucrative post of guardian of the slaves is held by a Neapolitan renegade.

For some time past, a furious war has raged between the states of Algiers and Tunis; the former, the more powerful of the two, being ambitious of

conquering its weaker neighbour. The Bey of Tunis can call out a force of from 40,000 to 50,000 men; but they are merely an armed mob, and scarcely present the semblance of a regular army. The Algerine troops, however, are precisely of the same description. In the spring of 1807, the two armies took the field. That of Tunis was highly appointed, and thought of nothing less than the conquest of the Algerine province of Constantina. But so soon as the advanced guard of the Algerines was seen reconnoitring, the whole Tunisian army turned, threw down their arms, and fled with the utmost rapidity in every direction. Many are said to have arrived at Tunis, without having once ventured to look behind. The Algerines took possession of their camp, baggage, and 15,000 camels, laden with every kind of supplies. It is supposed that nothing but the dread that so easy a victory might be the effect of stratagem, prevented the enemy from marching forward, and entering Tunis.

The army of the Bey, however, reassembled almost as quickly as it had dispersed; and in July he was again able to take the field. On the 13th, the two armies approached each other; and the advanced guards having met, the troops of Tunis began to fly in confusion. But a Greek slave having ventured to fire a cannon, the Algerines took the alarm, and retreated precipitately to their own camp. The Tunisians having thereafter rallied, the two armies remained all next day in sight of each other. In the evening, however, Soliman Kiaya, having gone up the mountains to reconnoitre with a small body of cavalry, the Algerines began to dread, that an attempt was making to surround them; upon which, the whole army broke up, and fled precipitately in every direction, leaving their camp, baggage, and 10,000 camels, in the hands of the victors. The latter, satiated with plunder, were not inclined to advance, otherwise they might easily have taken possession of Constantina. We need scarcely add, that such combats were not attended with serious bloodshed; they were sufficient, however, to deter these heroes from again taking the field, and the war was thenceforth carried on by petty skirmishes.

The government of Tripoli presents a still darker picture than that of Tunis. The flourishing era in the history of this state, was the reign of Hamet the Great, at the commencement of the last century. He freed Tripoli from the Turkish yoke, in a manner worthy indeed of so barbarous an administration. He invited to a feast 300 of their chiefs, each of whom, as they successively entered, were strangled. At the same time, a general massacre took place in the city. The Porte being propitiated by presents, he was left to reign in tranquillity. He reduced to complete subjection the hitherto untractable possessors of the mountain districts of Garian and Mesulata; and even succeeded in rendering Fezzan his tributary. He invited foreigners to settle in his dominions, and promoted the manufactures of woollen stuffs, Morocco leather, &c. His popularity enabled him to render the crown hereditary in his family. The late Bashaw reigned for thirty years with great moderation and mildness; and Tripoli assumed a civilized and pacific character, very unusual in this part of the world. A

Barbary
States.

Tripoli.

Barbary States.

most unfavourable change has taken place in his son Yusuf, the present Bashaw. He began his career by murdering his elder brother, an amiable prince, in the most barbarous manner. Then surrounding himself, by negro slaves and Arabs, he gained an ascendancy over the more pacific inhabitants of the city. He thus succeeded in driving out his second brother, and seizing on the sovereignty. He is represented as uniting in himself all the vices of that worst of characters, a Barbary despot. He has, in a great measure, ruined commerce, by monopolizing to himself all the lucrative and important branches. His principal minister is Sidi Hamet, who shares with his master the most decided partiality to the French, and enmity to the English. Lord Nelson, in 1798, sent a line of battle ship to demand that the Bashaw should for ever remove from his councils so dangerous a subject. A feigned compliance took place, but lasted only till the English ship was out of sight of Tripoli. This personage has since been raised to a higher situation, that of minister for foreign affairs, while his creature Mustapha has been appointed captain of the port. The place of first admiral is held by a person bearing the name of Murat Rais, but who is in reality a Scotsman, named Peter Lysle. Being at Tripoli in 1792, as mate of an English vessel, and accused of plundering part of the cargo, he fled to the castle, embraced Mahometanism, and received a command in the Tripoline navy. He soon distinguished himself in the capacity of a pirate, and rose by degrees to his present high situation. He is said, however, to enjoy it but little, and to sigh still for the loss of his country, and his friends.

Religion.

The religion of Barbary is well known to be throughout Mahometan, professed with a degree of rigour and intolerance unknown in any other region of the globe. There is not, however, as in Turkey, any great body, like the Ulema, to act as the depository of its doctrines and influence. This influence is here enjoyed by individuals who raise themselves, by personal merit or demerit, to the character of saints. Saints, in Morocco, almost share with the sovereign the power of the empire. Sidi Ali and Sidi Alarbi are the two most eminent reigning saints. Their consideration is chiefly supported by working miracles, and does not require any sacrifice of the pleasures of life. They indulge in all these without reserve, and, besides the usual number of wives, keep numerous concubines. The districts in which these saints reside pay no taxes, and are subject to no authority, except theirs; and they are perpetually surrounded by a body of armed men, to chastise their own enemies and those of the prophet. At some distance from Tripoli, there is a fortified village possessed by a saint, called the Lion, which serves as an asylum for every species of criminals, even those who are guilty of high treason. Idiots, throughout Barbary, are generally reputed saints; and some, in order to maintain the reputation of sanctity, find it expedient to counterfeit the total absence of reason.

Amount of the Population.

The population of Barbary has been very variously reported, and has never been fixed on any precise or authentic data. We shall collect the different statements made on the subject. Mr Jackson gives the

population of Morocco at 14,886,600; of whom the cities and towns contain 895,600; the provinces within Atlas 10,341,000; the Berebbers amount to 3,000,000, the Taflets to 650,000. He states these numbers to be founded upon information extracted from the Imperial Register. They are quite improbable, and very far beyond any estimate formed by preceding travellers. Chenier does not conceive that the empire can contain above six millions; and some have even reduced the estimate so low as two. Mr Macgill heard the population of the Tunisian territory generally estimated at five millions; but is inclined to reduce the estimate to half that amount. Of these he supposes that 7000 may be Turks, 100,000 Jews, 7000 Christians; the rest Moors, Arabs, and renegadoes. Of the Algerine territory we have seen no estimate; but being more extensive and equally cultivated with that of Tunis, it must contain a greater population. Tripoli is reckoned by Ali Bey to contain two millions; probably beyond the truth. Of the great cities, Morocco is generally supposed to contain 30,000; Fez, by Jackson, 380,000; by Ali Bey, only 100,000; Tunis, by Mr Macgill, 100,000; by Mr Blaquiere, 130,000; Algiers, by Dr Shaw, 117,000; Tripoli, by Mr Blaquiere, 25,000; by Ali Bey, only 15,000.

Barbary States.

With a soil so fertile, and where manufacturing industry is in so low a state, the productions of the earth must form the staple articles of export. Barbary, in ancient and even in modern times, has been the granary of southern Europe. Of late, however, this branch of trade has been nearly cut off by a general prohibition, in all the states, against the exportation of corn. The materials for export are thus reduced to fruits, gums, hides, wax, and the produce of the very few manufactures which flourish throughout these states. Of these, Morocco leather is the most important. Fez is the place where this manufacture flourishes in the highest perfection; but it is also carried on in the other cities of Morocco, as well as those of Eastern Barbary. Fez is also distinguished by the manufacture of woollen haiks, a species of long cloths universally worn by the Moors when they go abroad; of sashes and silk handkerchiefs; and of carpets, which are little inferior to those of Turkey. Tunis is famous for the manufacture of a species of conical woollen caps, called scu^l-caps; universally worn, not only in Barbary, but over the Levant. This fabric formerly employed fifty thousand persons; but the manufacturers of Leghorn and Marseilles now imitate it, and succeed in underselling the Tunisians, though, in the quality of the stuff, the latter remain still unrivalled. Robes and shawls of woollen gauze are also made to a great extent. Concerning the manufactures of Algiers and Tripoli, we have few details; but with the exception of caps, they appear to be nearly similar to those of Tunis.

The caravan trade with the interior of Africa is chiefly carried on from Morocco and Tripoli. From the former it is very extensive. The caravans carry chiefly salt, tobacco, and European goods; they bring back slaves, ivory, and gold dust. Lempriere estimates the amount of the former at one million; the latter at ten millions; which, if correct, would imply the profits on this trade to be immense. The

Barbary States.

trade from Tripoli has been greatly diminished, in consequence of the Bashaw having embroiled himself with his Arab neighbours, who, occupying the route by which the caravans must pass, render the communication extremely precarious.

The European goods for which there exists a demand in the Barbary States, are exceedingly various. They include more or less of almost every article both of manufacture and of colonial produce. In the former class are such articles as, being of inferior quality, can be afforded at a cheap rate; Yorkshire cloths, particularly druggets and serges; muslins of the coarsest and cheapest sort; coarse linen, particularly German. Raw silk and Spanish wool were imported to a great extent when their manufactures were more flourishing. French wines are imported into the eastern states, where the precepts of Mahomet are less rigidly observed. The other imports are tin and lead to a considerable extent, English is preferred; coffee, sugar, and the different kinds of spices: hardware, cutlery, toys, are in some demand; also alum, vitriol, cochineal, gum-lac, and vermilion, for their manufactures.

The commerce of Morocco is greatly diminished by the senseless bigotry of the reigning Emperor. The intercourse with Europe is now confined to the port of Mogadore, and is subject to various restrictions. The articles of export, suited to the European market, appear, by Mr Jackson's enumeration, to be chiefly sweet and bitter almonds, about 1,000,000 lbs.; gum Barbary, gum Senegal, and gum Sandarac, upwards of 100,000 lbs.; cow and calf skins, 260,000 lbs.; goat-skins, 10,000 dozen; wool, 30,000 lbs.; ostrich feathers, olive oil, citrons, and some minor articles.

The commerce of Eastern Barbary has hitherto been carried on chiefly from Leghorn and Marseilles. Louis XIV. established at the latter port a Royal African Company, which formed several establishments upon the coast of the Algerine province of Constantina. The objects were the corn trade and the coral fishery, which they shared at first with an English company already established; but the latter failing, the whole trade fell into the hands of the French. Their first establishment was at the *Bastion de France*, at the western extremity of Algiers; but this was abandoned, and they settled at La Cala, Bona, Il Col, and Tabarca. They paid L. 4000 a-year to the Dey of Algiers, and 100 per cent. to the Bey of Constantina, on the grain exported; in addition to which, they were obliged to submit to various species of extortion and humiliation. The Continental war, and the extinction of the French naval power, threw a large proportion of this trade into the hands of the British; and Malta became the channel through which it was conducted. In 1806, the British Government contracted with the Dey of Algiers for the possession of La Cala, Bona, and Il Col; in consideration of which, they stipulated to pay him the sum of 50,000 dollars (L. 11,000 Sterling). Mr Blaquiere, and other persons acquainted with this coast, are of opinion, that very important advantages might be derived from this settlement. The coral fishery alone might employ 500 boats and 9000 men; besides which, there is a large export of

hides, wax, and wool. It is added, that the country produces ship-timber, particularly oak, of the best quality, and in inexhaustible abundance, and that excellent hemp and flax might be raised. As yet, however, the British Government have continued to pay the money, without forming any establishment, or deriving any benefit from the privilege thus purchased. The coral fishery is carried on by a small number of French and Neapolitan boats; and the spirited attempts made by the merchants at Malta to open a communication with this quarter have been frustrated. From the pressure of the war, or other causes, no military establishment has yet been formed at La Cala. The place, however, is said to be admirably suited for such a purpose, and, at a very small expence, might be rendered impregnable.

We shall finally consider these states under the Christian view, which has so justly excited the interest and sympathy of the British nation, that of Christian slavery. To be placed under the absolute control of the most brutal and corrupted of mortals, whom religious antipathy has divested besides of every human sympathy—without any law or earthly power to appeal to—the hopeless victims of brutal cruelty, and still more brutal voluptuousness;—this is certainly the most dreadful fate to which human beings were ever devoted. Yet such has been the fate of thousands of Europeans, among whom were often those who, from rank, sex, and cultivation of mind, must have been most keenly sensible of its horrors. Painful as the subject is, it seems indispensable to give some details which may illustrate the extent of the evil, and the necessity which existed for some arrangements to remedy it.

The most particular and authentic account of the treatment of slaves at Algiers is that given in the American work already alluded to. On the 23d October 1792, the ship President saw approaching an armed xebec, bearing Spanish colours, till she came within gun-shot, when she instantly hoisted the bloody flag, and fired. Escape was now impossible; the xebec instantly put out a boat, with thirty armed men, who rowed furiously towards the vessel, and boarded it with the wildest shouts and outcries. No resistance being made, they began to strip the crew with a fury of avarice, of which it was impossible to form an idea. Sometimes several fell upon one American, and fought over him for the clothes of which he was stript. Having ransacked every corner, they then ordered the Americans to descend into the boat; and those who showed any hesitation were instantly knocked down, and kicked over into it. On reaching Algiers, the distribution took place. The Dey made first his choice, which was formerly limited to an eighth of the whole, but now extends to as great a number as he chooses to demand. For this purpose, they were conducted to the palace, and drawn up in files along a court, where they passed under this review. Having made his selection, he dismissed the rest with the compliment, "Go, you Christian dogs, and eat stones." The youngest were employed in menial offices about the palace, the rest were put to work in the marine and in public buildings. Whenever a foreign vessel was in the port, they were loaded with thirty or forty pounds weight

Barbary States.

Barbary States.

of chains, in order to prevent their escape. Their heaviest labour consisted in dragging immense stones from a neighbouring quarry, for the repair and enlargement of the mole. A body of Turks attended to urge them on, but gave no aid, unless by continually roaring out *Hyomoly*, "heave away," with a noise so tremendous, that it was heard at the distance of more than a league. At night, they were locked up in two huge buildings, called bagnios, the lower part of which was employed for shops, and the upper for the joint accommodation of the captives and of the wild beasts belonging to the Dey. There was no bed in the place, and they were obliged to lie on the floor, till their own ingenuity enabled them to erect some humble substitute. The daily allowance of food was a pound of very bad bread, and a small quantity of oil. Many sunk under this accumulation of distress, and were carried to the Spanish hospital, the only relief provided for their miseries. The sympathy of the American people having been at length excited by reports of their sufferings, they opened a negotiation, and, at the expence of nearly 800,000 dollars, procured the release of the captives.

The observations made by Captain Croker, during his visit in 1815, agree with the narrative of the Americans, and prove that no improvement had taken place since that time. At the period of his arrival, three hundred Christian captives had been driven in from Bona, exposed to such treatment that fifty died within six days after reaching Algiers. They were still employed in the quarries, and loaded with chains, as before. His description of the house in which they were locked up is, that, "if it had light," it would resemble those in which the West Indian negroes keep their pigs. Being now at peace with the great powers, their piracy is chiefly exercised on Naples and Sardinia, with whom they have always taken care to continue at war. European, and even English colours, are assumed to entrap the unfortunate victims. They frequently also make descents on the coast, and sweep away all the inhabitants, without distinction of age and sex. The Tunisians, at the commencement of the reign of the present Bey, landed on the island of St Pierre, belonging to Sardinia, and carried off the whole population, amounting to upwards of a thousand. At Tunis and Tripoli, the treatment of slaves is not so utterly inhuman as at Algiers. The most dreadful fate is that of those who are judged fit to be received into the haram of the prince, or any of his principal officers; which, in consequence of the depraved propensities here prevalent, is not confined to one sex. Of those who become the slaves of private persons, both at Tunis and Algiers, some are tolerably, and a few very well treated.

It is not easy to ascertain the precise extent in which this enormous evil lately existed. Mr Blaquiere, though he represents its horrors in the most glowing colours, considers the whole number of captives as amounting only to a thousand. Mr Macgill calculates two thousand in Tunis alone, and the Americans the same number at Algiers. The first estimate, however, is probably the more correct, as, by a calculation of the amount and rate of ransoms returned, the number in

VOL. II. PART I.

Barbary States.

Algiers, at the time of Lord Exmouth's first expedition, appears to have been four hundred and fifteen.

The outrageous conduct of the Barbary corsairs has repeatedly roused the indignation of the principal European states. Yet it has happened, that most of the expeditions undertaken to repress or intimidate them have been not only unsuccessful, but attended with the most disastrous issue. We may particularly mention the expedition of Charles V., which will be found narrated in the body of the work. More recently, in 1776, the Spaniards sent a large fleet into the road of Algiers, which landed 13,000 or 14,000 troops. Through a want of harmony, however, between the commanders, the army reembarked, and the fleet sailed off without attempting anything of importance. They returned in 1783, when the fortifications were greatly strengthened, but by means of gunboats, they were enabled to bombard the city in a terrible manner. Yet the Dey, though obliged to leave his palace, was neither moved by his own danger, nor by the sufferings of his subjects, to sue for peace; and the Spaniards at length retired. They returned next year; but the Dey had now prepared a large force of gunboats, which kept them at a distance; and they were obliged to move off, without having effected anything whatever. The Algerines now believed themselves invincible; and the Spaniards were fain to purchase peace with a million of dollars, besides a large sum for the ransom of their captives.

In 1800, the Americans waged war against Tripoli, in consequence of a vessel belonging to them having been seized, and the crew made slaves. They repeatedly attacked the harbour, and did some damage to it, but were not able to make any serious impression, or to produce any effect, besides that of impelling the tyrant to a more rigorous treatment of his captives. They then adopted a different course. They landed in Egypt, where they were joined by Hamet, the elder brother of Yusuf, the reigning Bashaw, and to whom the throne rightfully belonged. The confederates having collected 500 men, marched through the Lybian desert, and took Derne, the frontier town of Tripoli. Notwithstanding the smallness of this force, Yusuf, alarmed by the popularity of his brother, accepted the mediation of the Danish consul, and a treaty was concluded. The prisoners were restored at a moderate ransom, and Hamet, now abandoned, returned to Egypt. Upon the whole, there seems to have been very little ground for the boast which has been made, respecting the conduct and success of this American expedition.

After the termination of the Continental war, which had absorbed every other interest, a deep feeling was excited in the British nation, for the fate of their fellow Christians, who were groaning under this horrible slavery. Sicily and Sardinia, the chief sufferers, were our intimate allies; besides which, Britain, as mistress of the seas, seemed called upon to put down a system of naval warfare and depredation, inconsistent with all those ties by which civilized nations are united together. Urged by this impulse, the British Government directed Lord Exmouth (late Sir E. Pellew) to sail with a squadron against Algiers and

P

Barbary
States
Barlow.

Tunis. The appearance of this armament was sufficient to induce both states to a compliance with the terms demanded, which were, peace with Sicily and Sardinia; the restoration of their captives at a moderate ransom; and an engagement, in every future war, to treat prisoners in the manner customary among civilized nations. Scarcely, however, had this treaty been signed, when it was violated, on the part of Algiers, in the most outrageous manner. Several hundred boats, chiefly Neapolitan, being employed under sanction of the British flag, in carrying on the pearl-fishery on the coast near Bona, a gun was suddenly fired from the castle, when two thousand Turks and Moors rushed down upon the unfortunate fishermen, and, aided by fire from the forts, massacred the whole of them. The English flag was seized, and trampled under foot. Lord Exmouth had already sailed, and was arrived in England before he heard of this dreadful tragedy. The utmost expedition was then employed to equip a new and more formidable armament. In a few weeks Lord Exmouth again sailed, and being joined at Gibraltar by a Dutch squadron under Admiral Capellen, arrived before Algiers, on the 26th August last (1816), about three months from the time at which he had left it. On the morning of the 27th, a flag of truce was sent in, stating the conditions on which alone peace would now be granted, and allowing two hours for their acceptance. Three hours elapsed, without an answer, but also without any hostile movement; and Lord Exmouth began to hope the intentions of the Dey might be pacific, when several shots were fired from the harbour. A combat of the most terrible description immediately began, the batteries being attacked with all the characteristic valour of British seamen, and defended with all the fury of barbarian desperation. The British fleet suffered severely;

but after seven hours fighting, the enemy's batteries were reduced to a state of ruin; and the flotilla having succeeded in setting fire to some of the Algerine vessels, the flame spread to such a degree, that the whole fleet, arsenal, and gunboats, were ere long reduced to ashes. On the following morning, the Dey submitted unconditionally to the terms prescribed by the British Government. These were—the abolition, for ever, of Christian slavery; the immediate delivery, to Lord Exmouth, of all captives, of whatever nation, who were within the territory of Algiers; the repayment of the ransoms formerly received; with apology and reparation to the British consul, for insults that had been offered to him. All these stipulations were executed with the utmost promptitude.

Barbary
States
Barlow.

Thus terminated an achievement, than which none has ever reflected a purer glory on the British name—one undertaken, not from any merely British motives, but to defend the general cause of humanity, and vindicate the rights of the civilized world. All observers agree that, in the case of a race at once mean and barbarous, fear is the only motive which can act with sufficient force; and that a signal chastisement, such as cannot be soon forgotten, affords the only security for their future moderation. The lesson which the Algerines have now received is of this description; and there is therefore every reason to hope that its influence may be long and salutary.

See *Shaw's Travels*; *Jackson's Account of Morocco*; *Macgill's Account of Tunis*; *Blaquiere's Letters on Sicily*; *Tully's Letters*; *Ali Bey's Travels*; *Keatinge's Travels*; Appendix to *Robert Adam's Travels in the Interior of Africa*; *Account of Algiers, and of the Treatment of American Captives*, by James Wilson Stephens, of Philadelphia. Brooklyn, 1800. (v.)

BARLOW (JOEL), an American literary and political character of considerable note, was born in the year 1756, in the village of Reading, State of Connecticut; and appears to have been the youngest of ten children. His father died when he was yet a boy; but his friends, attentive to his instruction, employed his portion of the paternal inheritance for his education, at the college of Newhaven, in his native state. Here he commenced his studies in 1774. In the course of the prescribed exercises of composition, he discovered a taste for poetry; and two productions crept into public view; one entitled *The Prospect of Peace*; the other, *An Elegy on the Death of Mr Hosmer*, Member of the American Congress. It appears that Mr Barlow was destined for the clerical profession; and that his friends solicited and obtained for him the appointment of chaplain to a militia company of Massachusetts, the functions of which he performed till the event of peace. One of his panegyrists has observed, in reference to his subsequent change of profession, that, "amongst the Presbyterians of New England, the priesthood is nothing else than a species of civil ordination. He who receives it may pass to another employment; and it is common enough to see young

men preach the gospel in order to have time to prepare themselves for another profession." This explanation, however, is hardly reconcilable with the spirit of the New England theologians, who even now require from the candidate for holy orders a solemn declaration, that he is moved to this calling by a certain species of inspiration, or divine impulse, and not by any carnal or interested motive.

In 1781, while he followed the army in quality of chaplain, he contracted a marriage with Miss Baldwin of Newhaven; and it was during this period of his life that he planned the edifice of his future fame in his poem destined to celebrate the discovery and prospects of America.

It was also during this period that the patriarchs of Connecticut proposed to adopt a new metrical translation of the Psalms, which excited to emulation all the poetical genius of the state. The version of Barlow carried the prize; and is to this day sung in the churches of New England.

At the conclusion of peace between the United States and Great Britain, he abandoned the ecclesiastical life, and settled at the village of Hartford, where, two years afterwards, he published the poem alluded to, entitled, *The Vision of Colum-*

Barlow. *bus*, which he afterwards gave to the world in a more expanded and imposing form.

After quitting the service of the church, he appears for some time to have practised law; but, in 1788, he likewise abandoned that profession to become the agent of a mercantile company, who had purchased some millions of acres of lands situate on, or near the river *Ohio*, which they proposed to sell to foreigners at an enhanced price. For this purpose, Mr Barlow was sent to Europe; and it is said that he was fortunate in the execution of this commission.

Having during this period become deeply interested by the events of the French Revolution, he published, in the years 1791 and 1792, the following political pieces: 1. *Advice to the Privileged Orders*.—2. *The Conspiracy of Kings*.—3. *Letter to the National Convention of France*.—4. *The Royal Recollections*. Towards the end of the year 1792, he was, being then in London, appointed by the Constitutional Society of London one of a deputation to present an address to the National Convention of France,—a circumstance which attracted the notice of the British Parliament, it having been stated by a member that the Convention had received an address by means of two fellows calling themselves the representatives of Great Britain, viz. Frost and Barlow.

In 1793, Barlow, from motives of curiosity, accompanied the four commissioners of the National Convention who were sent to Montblanc, to organize that department; and this excursion gave rise to another production, entitled, *A Letter to the People of Piedmont*. He also translated about this time Volney's well known work, entitled, *Ruins of Empires*.

Objects of a commercial nature at length drew him to Hamburgh, and afterwards to the coast of Africa, where he received the commission of consul-general of the United States, with instructions to enter into and conclude treaties with the Barbary powers, for the purpose of procuring the ransom of the American citizens who were detained as slaves in those countries. The execution of this commission was prompt and fortunate; and, after residing for some time in Paris, to which he returned from Barbary, he, in 1805, proceeded to America, and purchased a neat habitation in the territory of Columbia, the seat of the general government, to which he gave the name of *Kahrama*. Here he formed an acquaintance with certain considerable members of Congress, to whom he greatly recommended himself by the publication of a short sketch of a plan of national education, and an address to the citizens of Washington upon occasion of one of the anniversaries of American independence. He now also published the superb quarto edition of his national poem, to which he finally gave the name of *The Columbiad*.

Soon after his return from Europe, he was admitted to the confidence of the first magistrate of the United States; and, in 1811, he received the valued appointment of minister-plenipotentiary to the court of France. This nomination met with powerful op-

position in the Senate, and passed only by a small majority.

He sailed for his destination on board of the Constitution frigate, disembarked at Cherbourg in September 1812, and proceeded to the French capital, where he was received, in the Emperor's absence, by the minister of foreign affairs, who "was instructed to say the most flattering things relative to his appointment." The great object of his mission was to obtain compensation for the American property confiscated in virtue of the Berlin and Milan decrees. This arrangement was to be regulated in a manner the least onerous to the French treasury. American ships and cargoes were, at the same time, to be freed from unjust detention, and a new commercial treaty to be formed on principles of national justice and reciprocity.

In pursuit of this object, he followed the Emperor Napoleon to Wilna, in the memorable winter of 1812; but this diplomatic journey was without advantage, and the failure was the more mortifying, as it was undertaken without the advice or instructions of the American Government. Mr Barlow was returning to Paris, when he was seized with a violent inflammatory disease, of which he died, on the 26th of December, in the 58th year of his age. His nephew, late midshipman on board of the Constitution frigate, whom he took from his studies to accompany him in this journey, and a secretary of the French Legation in the United States, were witnesses of his last moments, and saw him interred at the place where he closed his eyes, an obscure village of Poland.

Of the private life of Mr Barlow there is but little to say. He was of a very taciturn disposition; and though he had lived so long abroad, was in manners and appearance a true New England man. His life was sober and uniform. His court dress, though plain, he called his *harness*. He left no issue; but his wife survived him, and returned to America, to the enjoyment of considerable property bequeathed by her husband.

To this account of Mr Barlow, for which we are indebted to a correspondent abroad, to whom he was known, we shall subjoin the estimate which has been formed of his great work the *Columbiad*, by a very competent critic. "In this poem, the whole history, past, present, and future, of America, is delivered in the clumsy and revolting form of a miraculous vision; and thus truth is not only blended with falsehood and fancy, but is presented to the mind under the mask of the grossest and most palpable fiction.—From the prose which he has introduced into the volume, and even from much of what is given as poetry, it is easy to see that he was a man of a plain, strong, and resolute understanding; but without any play or vivacity of fancy, any gift of simplicity or pathos, any loftiness of genius, or delicacy of taste. Though not deficient in literature, nor unread in poetry, he had evidently none of the higher elements of a poet in his composition; and has accordingly made a most injudicious choice and unfortunate application of the models which lay before him. Instead of aspiring to emulate the sub-

Barlow.

Barlow.

Barlow
||
Barometer.

lime composure of Milton, or the natural eloquence and flowing nervousness of Dryden, he has bethought him of transferring to epic poetry the light, sparkling, and tawdry diction of Darwin; and of narrating great events, and delivering lofty precepts, in an

unhappy imitation of that picturesque, puerile, and pedantic style, which alternately charms and disgusts us in the pages of our poetical physiologist." (*Edinburgh Review*, Vol. XV.)

Barlow
||
Barometer.

B A R O M E T E R.

THE *Encyclopædia* contains such an account of the discovery and construction of this most valuable instrument, as could be drawn from the popular treatises of natural philosophy in the English language. But, unfortunately, our compilers of elementary works have seldom taken the trouble to remount to the original sources of information, and have frequently, by substituting their own fancies, or servilely copying the mistakes of others, contrived to disfigure egregiously the relation of facts, and the history of the progress of invention. We now purpose, therefore, as far as our limits will admit, to remodel the article; and, passing rather slightly over the description of the different kinds of barometers, and other practical details already given, to dwell more especially on the successive steps which led to the fine discovery of atmospheric pressure, and its application to physical science.

Opinions
of the
Ancients :

The opinions entertained by the ancients concerning physical subjects, appear at best only splendid visions. They speculated boldly in cosmological theories, but were easily satisfied with those conclusions which merely soothe the fancy. Many of the philosophical notions, however, adopted in remote ages, have left a durable impression in the structure of language, and still continue to exert a visible influence in moulding the current sentiments of mankind. The early sages of Greece distinguished matter into the four primary elements, of earth, water, air, and fire, which, by their various combinations, were supposed to produce the animated spectacle of the universe. With these elements were associated corresponding qualities, in a binary conjunction: Hot and cold; dry and moist. Earth and water were considered as ponderous and inert; but air and fire, endued with elastic virtue, were imagined to possess lightness and activity. Fire, though extracted from all bodies by the operations of nature or of art, was yet conceived to be derived, by invisible emanation, from that diffuse lambent fluid, which, under the name of *Æther*, occupied the highest heavens, and constituted the substance and nutriment of the celestial bodies. While the earthy matter would, therefore, naturally settle towards the centre, and the aqueous fluids roll along the surface, of the solid globe; the air and fire soared aloft, the former occupying the whole of the region below the moon, and the latter streaming through the boundless extent of space. This sublunary scene is exposed to incessant change, calamity, and decay; but above it was supposed to reign a perpetual calm, the seat of bliss, and of divine and imperishable essence.

Aristotle, and some other philosophers, viewing *æther* as altogether distinct from culinary fire, were

disposed, however, to consider it as a *fifth* element, of a pure, divine, and incorruptible nature; an opinion which afterwards gave occasion to the famous *Quinta Essentia*, or *Quintessence* of the schoolmen. The alchemists, who sprung up nearly about the same benighted period, in adopting those notions, modified them to suit their own peculiar views. To the elements commonly received, they joined the active auxiliaries of *mercury* and *sulphur*. For *quintessence* they substituted *spirit* and *elixir*; the former, drawn off by the application of fire, being conceived to represent the animating principle of each body; while the latter, extracted by the combined action of heat and moisture, was supposed to exhibit its concentrated and most select qualities.

Some of the ancient cosmologists supposed a vacuum beyond the shining expanse of *æther*, destined to receive the exhalations from this nether world. Others denied the existence of a separate void, but admitted small vacuities interspersed through bodies. Aristotle, however, maintained the necessity of a plenum, asserting that our idea of space or extension is inseparable from that of body. To this principle he ascribed the suspension of water in a tube, when the finger is applied to shut the upper end. Yet the very contempt in which that philosopher, from a consciousness of his own superiority, was accustomed to hold the received opinions, might have led him to take juster views. He rejected the notion, that air has levity inherent in its nature; nor would he admit the more plausible idea, that a fluid so easily moved must possess the quality of perfect indifference, and be neither light nor heavy. Aristotle not only maintained that air is ponderous, but did not scruple to appeal to direct experiment in support of his assertion. A bladder, he says, will be found to gain some weight, on being blown or filled with air. But this was evidently a mere random assertion, betraying his ignorance of the constitution of fluids. A bag filled with air, and suspended in a like medium, it is obvious, from the laws of hydrostatics, must weigh exactly the same as before. If it be alleged that, in blowing up the bladder, a portion of air would be introduced immediately from the lungs, and containing, therefore, a small admixture of carbonic acid gas, which is specifically lighter than the common atmospheric fluid; the additional weight, amounting scarcely perhaps to a grain, would be too minute to be detected by any of the jeweller's balances constructed in ancient Greece.

The mutual opposition of the leading philosophical sects of antiquity had, in general, most fatally discouraged the application of mathematical reasoning to the system of the material world. The Academi-

Physical
Tenets of
Aristotle.

Barometer. cians, or the disciples of Plato, who cultivated geometry with ardour and brilliant success, were disposed to regard that science as a pure intellectual contemplation; and resigning themselves to the illusion of their lofty dreams, they turned with disdain from the investigation of individual facts and all the vulgar realities of life. The mind of Aristotle was of a more sober and practical cast; acute, profound, and discriminating, it ranged, with incredible industry, over an immense field of inquiry. That judicious philosopher recommended a careful and constant appeal to external observation, as the only sure ground on which to erect the structure of physics; but unfortunately his scholars neglected too much the study of mathematics, the most powerful instrument for conducting physical research. The precepts of Aristotle, though excellent in some respects, were hence in the sequel unproductive of any genuine fruit. On the contrary, the weight of his opinions, during a long course of ages, confined and repressed the efforts of human genius.

Modern Experimentalists. It must be gratefully acknowledged, that the alchemists, styled also philosophers by fire, were the first among the moderns who dared to explore new paths of science. Their projects were, indeed, highly chimerical, but they had the merit at least of setting the example of investigating the properties of matter by actual experiment. They likewise formed associations among individuals, for the more effectual prosecution of such researches. Hence the origin of that obscure sect, known by the fanciful title of Rosicrucians, who sprung up in Germany, and insensibly spread their influence over the Continent. Those principles were afterwards transplanted into the matured soil of Italy, where philosophy, succeeding to the cultivation of letters, wore a more attractive garb. Baptista Porta, a Neapolitan nobleman, who flourished about the latter part of the sixteenth century, was especially distinguished by his zeal in promoting such pursuits. Having spent many years in travelling over Europe to gain information respecting natural objects, he invited a few individuals of a similar taste to assemble, at stated times, in his house, and assist him in making new experiments. These meetings, however, gave umbrage to the watchful jealousy of the clergy, and they were soon suppressed by a mandate from the Court of Rome. But the example was imitated in other parts of Italy, where the papal authority enjoyed less respect; and academies, for the promotion of natural science, were successfully instituted under the patronage of different princes, particularly those of the illustrious house of Medici.

Galileo. In this ferment of inquiry, Galileo arose, a man fitted alike by the gifts of nature, and the lights of education, to be the founder of experimental science. His elegant genius was invigorated by the study of the Greek geometry; and he conceived the happy and prolific idea of employing that refined instrument to explore facts and combine the results. Archimedes, indeed, among the ancients, had anticipated this road of discovery, having most successfully applied the powers of geometrical analysis to the investigation of some parts of mechanics and hydrostatics. But his was a solitary instance, unheeded by succeeding

ages. The ingenuity of Galileo prepared a complete revolution in science. By means of a few simple but striking experiments performed on the lagoons of Venice, he established the laws of motion, which he now transferred from the surface of our globe, to direct the revolutions of the heavenly bodies. The publication of his *Dialogues*, which unfold the right process of induction, and are not less distinguished by fineness of conception than beauty of diction, form a new era in the annals of philosophy. He was the first that attempted to ascertain the weight of air by actual experiment; and considering the nicety of the operation, and the rudeness of the instruments constructed at that period, he made a very tolerable approach to the truth. It had been known for many ages, that air is capable of being highly condensed; and Ctesebius of Alexandria had invented an engine, which, by the force of the sudden expansion of this compressed fluid, hurled missile weapons. This was afterwards improved into the wind or air-gun, which seems to have been not uncommon in Europe as early as the fifteenth century, though soon afterwards generally superseded in practice by the introduction of fire-arms. Galileo, being led by a different path from that pursued at present, set himself to examine the weight which air acquires by condensation. Having fitted a large copper vessel with a valve, he injected air into its cavity by means of a syringe, and then suspended it to a balance. The additional increase of weight being thus found, he opened the valve under an inverted glass receiver full of water, and measured, by the displacement of this liquid, the surplus quantity of air which had been injected into the copper vessel. He thence concluded that air is 400 times lighter than water, being about the double of the true estimate.

After he had, by such researches, acquired celebrity in the scientific world, Galileo accepted an invitation, with a very handsome appointment, from Cosmo de Medici; and devoting himself intensely to astronomical observations, aided by the telescope, which, from an obscure hint, he had recently constructed, yet occasionally unbending his mind with elegant recreation, he spent almost the whole of the evening of his life, at the villa of Arcetri, near Florence, in a style of comfort and even splendour. But, while occupied with those delightful pursuits—exploring the planetary phases—and discovering new worlds—he was for a moment recalled to his early studies, by an incident destined to form an epoch in the history of physical science. Some artisans, in the service of the Grand Duke, having been employed to construct a lifting or sucking pump for a very deep well, found, with equal surprise and vexation, that, in spite of all the pains they had taken in fitting the piston and valves, the water could by no effort be made to rise higher in the barrel than eighteen palms, or thirty-two feet. In this dilemma, they applied to Galileo for an explication of the cause of a failure so unexpected and perplexing. But the philosopher was not yet prepared to encounter such a discordant fact. The Aristotelian tenet of the impossibility of the existence of a void, was, at this period, universally received as an unquestionable truth. It had become a favourite axiom of the schoolmen, deceiving

Barometer.

Incidental failure of a Sucking Pump.

Barometer. themselves—as Leibnitz did afterwards, in proposing his principle of *sufficient reason*—by the glimmer of a metaphorical expression, the *fuga vacui*, or *nature's horror of a void*. To create a vacuum, they gravely maintained, would require the hand of Omnipotence, transcending the utmost power of men or even devils. But Galileo, though borne along by the current of opinion, saw the necessity of at least modifying the general principle. Without questioning nature's abhorrence of a vacuum, he supposed the influence of this horror to be confined within certain limits, not exceeding the pressure of a column of water eighteen palms in height. This was evidently evading, rather than meeting, the difficulty proposed for his solution. Yet, in the last of his Dialogues, he actually mentions an experiment to ascertain this power or *virtu*, as he calls it, of a vacuum. A piston, exactly fitted into a smooth hollow cylinder, was rammed quite to the end, and this carefully shut up; then placing the cylinder in an upright but inverted position, successive weights were appended to the rod, till it was drawn from the close end, and pulled down. It may seem strange, that the Tuscan philosopher, after advancing so far, should have stopt on the verge of a great discovery. He had already weighed the air, and it was only another small step thence to infer the effect of its incumbent mass. But the atmosphere was still supposed to reach to the moon, and the pressure of columns of such enormous height seemed to mock all calculation, and overwhelm the imagination.* Yet, on reconsidering the subject, Galileo began to suspect the solidity of the explication which he had given; but it was now too late for him, in his advanced age, loaded with bodily infirmities, and dispirited by clerical persecution, to attempt any farther innovation in science. Recommending it earnestly to his friend and pupil Torricelli to resume the investigation, this illustrious precursor of Newton expired in 1642, the very year in which the English philosopher was born. His uniform kindness and urbanity rendered him extremely beloved; and his disciples, particularly Torricelli, Viviani, and Ricci, venerating his memory, caught the same taste, and followed similar pursuits.

Timid and imperfect Explication of Galileo.

Torricelli's famous Experiment. Torricelli now conceived the happy idea of exhibiting the action of a pump on a contracted scale, by means of a column of mercury, which is nearly fourteen times heavier than water. This experiment he first communicated to his friend Viviani, who performed it with success in 1643; and he afterwards repeated and varied it himself. The method which he took brought very neatly under one view all the circumstances affecting the question. Having selected a tube about a quarter of an inch wide, and four feet long, he sealed

Barometer. one of the ends hermetically, or closed it under the flame of a lamp; he then filled the cavity of the tube with mercury, and applying his finger to the open end, he inverted it in a bason likewise containing mercury, though covered with a portion of water. The mercury instantly sunk to nearly thirty inches above the lower surface; but on raising the tube, till its orifice communicated with the layer of water, the mercury run all out, and the water now sprung up to the top, and occupied the whole of the cavity. It was thus proved, that the water and mercury are each supported by the same equipoise, which Torricelli, after some hesitation, at last concluded to be the pressure of the external atmosphere. He next converted the mercurial column into a form adapted for observation, by bending the lower end of the tube, and constructing what has since received the name of the *siphon barometer*. (See fig. 1. Plate XXXII.) Thus armed with a commodious instrument, he soon detected the variation of atmospheric pressure, which depends on the change of weather. These important results were published in the year 1645; but Torricelli did not live to enjoy the fame of his great discovery, for this most promising genius was snatched away by a putrid fever in the flower of his age.

The report of Torricelli's first experiments having been carried to France before he had ventured to draw his capital conclusion, set philosophers to speculate on the cause of such an unexpected fact. Descartes, with his usual rapidity and boldness of conception, did not hesitate, in his correspondence with Mersenne, to refer the suspension of the mercury in the tube at once to the pressure of the external atmosphere. But this influence appears not very consistent with his system, which assumed the existence of an absolute plenum, and only supplied the place of a void by the diffusion of subtile abraded particles of matter. He suspected also the accuracy of Galileo's estimate of the weight of the air, which he thought was scarcely appreciable by experiment.

But, in the same country, the subject was now pursued with deliberate caution, and through all its details, by another genius of the highest order; one of the finest and most original that France has ever produced. Pascal had shown premature and extraordinary talents, which were encouraged by his father, a man of learning, who lived in habits of intimacy with the literati of Paris. The young philosopher happened to be residing at Rouen, in 1646, when he was informed of the famous Italian experiment. Having access, fortunately, to a glass-house, he resolved immediately to repeat the observations on a large scale. He had already suspected the justness of the principle, that "nature abhors a vacuum," and thought that the condensation and rare-

* This narrative, which marks so well the slow and timid steps whereby men, even of the highest intellectual endowments, usually advance in the search after truth, is drawn from the writings of Galileo himself. The carelessness of some authors in mis-stating facts, and imputing unworthy motives to those patriarchs of science who could not open their eyes all at once to the bright effulgence of day, deserves severe reprehension. We may remark, in passing, that M. Biot, who ranks now among the first mathematicians and philosophers in France, has not scrupled, in a recent bulky compilation on physics, to allege that Galileo only joked with the artisans who asked him the reason of the failure of their pump; that he had an idea of the true explication, but chose to keep his secret, and suffered it to die with him. Such a contemptible conduct would certainly have been a reproach to Galileo's acknowledged candour.

Barometer. faction of the air point to a different, or at least a modified conclusion. With a view to clear up this subject, Pascal performed a number of satisfactory experiments, of which we shall cite a few of the more striking, nearly in his own language, tinged evidently with the prevailing opinions of the age: 1. Having fitted a piston to an open glass tube, and rammed it quite down, he applied his finger close to the lower end, and plunged the whole under water; then drawing back the piston, which was done with ease, the finger felt strongly and rather painfully attracted, while an apparent vacuity was formed above it, and continued to enlarge: but instantly on removing the finger, the water, contrary to its nature, darted up and filled the whole of the cavity. 2. A glass tube, about fifty feet long, sealed hermetically at one end, and filled with water, or rather red wine, as a more visible fluid, was inverted perpendicularly in a bason of the same. The liquid immediately subsided, leaving a vacant space of thirty-five feet; but, on gradually reclining the tube, the liquid rose again, and continued to mount, till it struck a sharp blow against the top of the glass. 3. A syphon, having one leg fifty-five feet high, and the other only fifty, being filled with water, and planted in two basons containing the same, such that the shorter branch had a perpendicular position, the water sunk in both to the same level, without being attracted, as usual in syphons, to the longer branch; but, on leaning the syphon back, the columns rose till they united at the top, and then the water began to flow towards the lower bason. The same experiment was also performed with mercury, the syphon having one leg ten feet, and the other only nine feet and a half in length, the mercury being found to divide itself into two columns, which continued suspended at an altitude of about thirty inches. 4. Having nicely fitted a piston to a long glass syringe, and pushed it down to the end, he immersed this in a bason of mercury, and held the tube in a vertical position; on gently drawing up the piston, the mercury closely followed it to the height of twenty-nine inches, but then stopt, leaving the piston to form above it an apparent vacuity. In this state, also, the syringe weighed exactly the same, whatever was the magnitude of the vacant space.

His cautious Induction.

From these and other similar experiments, Pascal led his inductive process, with a degree of caution that might seem to border on timidity. He inferred that all bodies have a reluctance to a visible separation, or that nature abhors an apparent void; that this reluctance is exactly the same for a small as for a great vacuity; and that the force is limited, and exceeds not the pressure of a column of water thirty-three feet in height. He next ventured one step farther, and concluded, that this apparent vacuity was not filled by air lodged in the pores of the glass, or derived from external filtration; that it contained no subtle matter secreted from the atmosphere, and was not occupied by mercurial vapours or spiritous exhalations; in short, that a real and absolute vacuum had been formed.

Attacked by Nöel.

Pascal, then only twenty-four years of age, proposed to write a treatise on the subject of those inquiries; but thought proper, in the meantime, to publish a short abstract of it, which appeared in 1647, and in-

volved him in a wretched controversy. Father Nöel, rector of the Jesuits' College at Paris, keenly attacked it, armed with all the miserable sophisms of the schools, and the absurd dogmas of the Romish church. He contended, that the space above the mercurial column was corporeal, because it was visible and admitted light; that a void being a mere non-entity, cannot have different degrees of magnitude; that the separation produced in the experiments was violent and unnatural; and he presupposed that the atmosphere, like blood, containing a mixture of the several elements, the fire and the finer part of the air were detached from it, and violently forced through the pores of the glass, to occupy the deserted space. To enforce these puerile arguments, the reverend Jesuit did not scruple to employ the poisoned weapon which his order has often wielded with deadly effect,—the hinting an oblique charge of heresy. This rude attack only roused Pascal, and disposed him boldly to throw off the fetters of inveterate opinion. He began to perceive that “abhorrence” cannot, in strict logic, be applied to nature, which is a mere personification, and incapable of passion; and was inclined, by degrees, to adopt the clear disembarassed explication of Torricelli, referring the suspension of the mercurial column to the pressure of the external atmosphere. In stating this conclusion, he makes some remarks which would deserve the serious attention of philosophers in the present age. “When the weakness of men is unable to find out the true causes of phenomena, they are apt to employ their subtlety in substituting imaginary ones, which they express by specious names that fill the ear, without satisfying the judgment. It is thus that the sympathy and antipathy of natural bodies are asserted to be the efficient and unequivocal causes of several effects, as if inanimate substances were really capable of sympathy and antipathy. The same thing may be said of the antiperistasis, and various other chimerical causes, which afford only a vain relief to the avidity of men to know hidden truths, and which, far from discovering them, only serve to conceal the ignorance of those who invent such explications, and nourish it in their followers.” These remarks, equally judicious and profound, are the more striking, since Lord Bacon, while he proposed to reform and remodel the whole structure of human learning, yet complied with the taste of his age in retaining much of the jargon and barbarous distinctions of the schools.

Barometer.

But Pascal did not rest satisfied with mere reasoning, however strictly conducted; and he soon devised an experiment which should palpably mark, under different circumstances, the varying effects of atmospheric pressure. It occurred to him, that, if the mercury in the Torricellian tube were really supported by the counterpoising weight of the atmosphere, it would be affected by the mass of superincumbent fluid, and must therefore partially subside in the higher elevations. He was impatient to have his conjecture tried in a favourable situation, and, in November 1647, he wrote a letter communicating those views to his brother-in-law, Perier, who filled an office of considerable trust in the province, and commonly resided at Clermont in Auvergne, in the immediate vicinity of the Puy de Dôme, a lofty con-

Pascal's decisive Experiment.

Barometer. cal mountain, which rose, according to estimation, above the altitude of 500 toises. Various avocations, however, prevented that intelligent person from complying with his instructions, till the following year. Early in the morning of the 19th of September 1648, a few curious friends joined him in the garden of a monastery, situate near the lowest part of the city of Clermont, where he had brought a quantity of mercury, and two glass tubes hermetically sealed at the top. These he filled and inverted, as usual, and found the mercury to stand in both at the same height, namely, 26 inches and $3\frac{1}{2}$ lines, or 28 English inches. Leaving one of the tubes behind, in the custody of the subprior, he proceeded with the other to the summit of the mountain, and repeated the experiment, when his party were surprised and delighted to see the mercury sink more than three inches under the former mark, and remain suspended at the height of 23 inches and 2 lines, or 24.7 English inches. In his descent from the mountain, he observed, at two several stations, that the mercury successively rose; and, on his return to the monastery, he found it stood exactly at the same point as at first. Encouraged by the success of this memorable experiment, Perier repeated it on the highest tower of Clermont, and noted a difference of two lines at an elevation of 20 toises. Pascal, on his part, as soon as the intelligence reached him at Paris, where he then chanced to be, made similar observations on the top of a high house, and in the belfry of the church of St Jacques des Boucheries, near the border of the Seine; and so much was he satisfied with the results, that he proposed already the application of the barometer for measuring the relative height of distant places on the surface of the globe.

Opposition which it experienced.

The investigation of the existence and effects of atmospheric pressure was now completed, and it threw a sudden blaze over the whole contexture of physical science. The fame of the experiments performed in Italy and in France, quickly spread over Europe. Yet such is the force of habit and early prejudice, that, after the first moments of surprise and confusion, few of the learned at this period had the courage to open their eyes to the light which had so unexpectedly burst upon them; but, secretly cherishing their inveterate notions, they sought to comfort themselves, by starting a variety of captious objections. Father Mersenne, though a man of some abilities, conceived that suction was occasioned by certain hooked particles dispersed through the atmosphere, which laid hold of any fluid in contact with them, and drew it towards the general mass. Father Linus, plunging still deeper in mysticism and absurdity, gravely proposed the *funicular hypothesis*, which attributes the suspension of the mercurial column to the agency of certain small invisible threads. But others of the clergy attacked Pascal with envenomed bitterness. The Jesuits of the college of Montserrat scrupled not, in their public theses, to pervert his expressions, and even contest the originality of his experiments. The philosopher was justly incensed at their base conduct; and those repeated provocations served, no doubt, to give a keener edge to his wit, when he afterwards directed it with such overwhelming energy against that insidious and formidable order of priesthood. He composed in 1653,

though they were not published till after his death, Barometer. two short treatises, *On the Equilibrium of Liquors*, and *On the Weight of the Mass of Air*, remarkable for their neatness, perspicuity, and lucid order. The laws of the equilibrium of fluids are there beautifully deduced from a single principle, which suggests a variety of original views and admirable remarks. In those tracts, he likewise gives a description of the Hydraulic Press, a most useful and powerful machine, which has lately been revived in this country, and considered as a new invention.

A similar discovery, which was made about the same time in Germany, came seasonably to support the triumph of innovation. Otto Gürkéké, a wealthy magistrate of Magdeburg, who amused his leisure by constructing pieces of mechanism, and instituting curious physical inquiries, finding that the belief in the impossibility of a vacuum, with other scholastic tenets, was on the gradual decline, had the boldness to conceive that the forming of a void was a task perhaps within the reach of human ingenuity. Fired with the idea of accomplishing what for ages had been deemed unattainable, he directed all his efforts to compass that end. In his first trials he failed, as might be expected; but, by perseverance, he was enabled to surmount every obstacle. Having filled a wooden cask with water, he attempted to extract this again, by means of a small sucking pump, introduced at the bottom of the cask, and worked vigorously by three stout men; a hissing noise was heard like that of boiling water, the air entered from above through the interstices of the wood, and the water flowed out. The more effectually to exclude the air, he next took a smaller cask, with a sucker attached to it, and placed it within a larger one, having filled up the space between them with water. On working the pump as before, the water was forced through the pores of the wood into the inner cask, but none was extracted by the action of the piston. Foiled in these attempts with wooden casks, he had recourse to a copper ball, to the under part of which he screwed an inclining sucker; and, with this apparatus, he at last succeeded in extracting the air. He continued the operation, till no farther portion of air was perceived to issue from the vent. On opening the cock again, the air rushed into the cavity of the ball with violence; and the same effect took place, with scarcely any diminution of power, after an interval of a day or two. The construction of the machine was afterwards rendered more perfect, by substituting a large inclined metal sucker, with its joints secured by immersion in water.

Such was the origin of that most valuable addition to philosophical apparatus—the air-pump, which long retained its earliest rude and simple form on the Continent. By help of this new and powerful instrument, Gürkéké was enabled to perform some interesting and very important experiments. One of these, which demonstrates in a very striking way the pressure of the atmosphere, has been since deservedly styled the Magdeburg Experiment. It was performed with two hollow copper hemispheres, closely fitted together, and the air exhausted from their cavity. This singular experiment Gürkéké had the honour of exhibiting, in the year 1654, before the princes of the

Barometer. empire and the foreign ministers, assembled at the diet of Ratisbon. The force of two teams, each consisting of a dozen of horses, made to pull in opposite directions, was found insufficient to separate the hemispheres. It was now that the Burgomaster of Magdeburg heard, for the first time, of Torricelli's great discovery, and the intelligence must have appeared quite delightful to him, who, by a path so different, had yet arrived at a similar conclusion.

After his return from this splendid assembly, Gùrické pursued at home various pneumatical researches. He showed the diminished pressure of the atmosphere at an elevation above the surface, by means of a hollow ball fitted with a stop-cock; having carried this to a height, a portion of the contained air rushed out on turning the cock; but when it was brought down again and opened, the same measure of air apparently flowed into its cavity. He actually weighed the air, by ascertaining, by a nice balance, the loss which a large bottle sustained on being exhausted, and found that air is 970 times lighter than water, a very near approximation, if allowance were made for the residuum of air still left in the bottle. He was the first who proposed the

Statistical Balance. *Statistical Balance* for measuring the variations of atmospheric density, consisting of a hollow glass ball about a foot in diameter, hermetically sealed, and freely suspended in the air, to indicate by its different buoyancy the changes which take place in the gravity of the external fluid.

But Gùrické took great pleasure in a huge water barometer erected in his house. It consisted of a tube above thirty feet high, rising along the wall, and terminated by a tall and rather wide tube hermetically sealed, containing a toy, of the shape of a man. The whole being filled with water, and set in a bason on the ground, the column of liquid settled to the proper altitude, and left the toy floating on its surface; but all the lower part of the tube being concealed under the wainscoting, the little image, or weather-mannikin, as he was called, made its appearance only when raised up into view in fine weather. This whimsical contrivance, which received the name of *anemoscope*, or *semper vivum*, excited among the populace vast admiration; and the worthy magistrate was in consequence shrewdly suspected by his townsmen of being too familiar with the powers of darkness.

Anemoscope.

Introduction of Experimental Science into England.

The taste for experimental science was about this time introduced from the Continent into England. The great struggle for the security of private rights had called forth the national energy, and its triumphant success had infused among all classes of men a spirit of boldness and enterprise most favourable to the reception of the new philosophy. The parliamentary commissioners, by removing the more violent and bigoted members of the universities, contributed, on the whole, to encourage a more liberal tone of thinking in those opulent seminaries. Near the close of the civil war, and during the vigorous administration of Cromwell, the philosophy by experiment found some proselytes at last among the chieftains of Oxford, where the mass of antiquated opinions had lain so long embalmed and protected by

religious awe. A small association was there formed, for combining together the efforts of individuals in the prosecution of such inquiries; and the fruits of this mutual compact were afterwards visible in the composition of various philosophical works. But the Restoration, by which the nation, in a burst of inconsiderate loyalty, surrendered the privileges which it had purchased with torrents of blood, threw the government of the universities again into the hands of men decidedly hostile to the very shadow of improvement. Experimental science withdrew to a more congenial soil, and sought shelter and support in the wider scope of the capital. The college founded by the munificence of Sir Thomas Gresham, for the benefit of the citizens of London, though now unfortunately sunk in absolute neglect, had the merit of first extending its protection to the pursuits of inductive philosophy. It produced a succession of professors, eminent in mathematical learning, which is so closely allied with experimental research. A more extensive association was accordingly formed in London, which regularly met at the apartments within the Exchange, and was afterwards, at the suggestion of Oldenburg, the resident from the city of Hamburg, and in imitation of the foreign academies, constituted by charter into the Royal Society. Such was the humble beginning of that illustrious body, and such was all the countenance it received from a needy and profligate government. The institution, however, proved at first eminently useful, by the influence it had in directing the public opinion, and the shelter it afforded to experimental philosophy against the jealousy and declared hostility of the clerical and scholastic seminaries. The union of rank, or wealth, or talent, though still very limited in its range, bestowed a degree of lustre on the infant society, that was quite necessary for its defence against the attacks of ignorance, and the mining of bigotry.

Barometer.
Royal Society.

One of the most active members of the Royal Society was Mr Boyle, who, having become acquainted with experimental researches in the course of his travels, devoted, after his return home, his time and his fortune to such calm but engaging pursuits. In this occupation, he derived the most essential aid from Dr Hook, whom he had the discernment to engage as his assistant,—the most skillful mechanic, and the best practical philosopher, of the age. The same ingenious person was likewise employed as operator to the society, and undertook to produce at each meeting some new experiments for the instruction and entertainment of the members. One of the favourite subjects was to exhibit the properties of the atmosphere. Dr Hook, at the instance of Mr Boyle, had given a more convenient form to the air-pump, and had materially improved its construction, especially by the application of oil to the joints and valves. With this improved machine, a more perfect vacuum was procured than Gùrické had obtained; and the English philosophers were thus enabled to perform a variety of delicate and interesting experiments, which extended the influence of the original discovery.

Boyle and Hook.

In those early meetings, too, of the Royal Society, the suspension of the mercury in the Torricellian tube had still the attraction of novelty. The famous

Barometer. Italian experiment, as it was called, was frequently repeated and varied in the presence of a few of the more assiduous members, who, though delighted with the exhibition, continued to reason and to doubt concerning the cause of the phenomenon. These doubts acquired new force from a singular experiment which the celebrated Huygens some years afterwards communicated, during a visit he made to London. Having filled a glass tube eighty inches long with mercury, and carefully expelled whatever air was lurking about the sides, he gently inverted it, as usual, in a bason; when the mercury notwithstanding remained still hanging from the top of the tube, and did not subside to the proper height, till it was struck with a slight blow. This anomalous fact appeared then extremely puzzling. The experiment, indeed, requires great nicety and address on the part of the operator, and evidently depends on a concurrence of circumstances which have not yet been sufficiently explained. There can, at present, exist no doubt that this extraordinary suspension of the mercury is occasioned by its obstinate adhesion to the inside of the tube, which, in the process of purging the air, becomes probably lined with a very thin film of mercurial oxyd. But Huygens, who had embraced the leading principles of the Cartesian philosophy, was inclined to draw a very different conclusion. He thought that the fact proved the existence of another fluid, besides the atmosphere, and one possessed of such extreme subtlety and power, as to be capable of permeating the grosser bodies. In ordinary cases, this fine ethereal substance might be supposed to escape through the pores of the glass, and leave the mercurial column to the mere pressure of the atmosphere. Such was the unfortunate introduction of that ideal being—an æther—into experimental science, which it has continued to infest with mysticism, and to dazzle with a false glare. Similar notions are perpetually renewed by a certain class of superficial inquirers, and have exercised a visible and most pernicious influence in retarding the progress of sound philosophy.

Cistern Barometer. It was soon perceived, that the syphon barometer of Torricelli has a disadvantageous form. Both branches of the tube being supposed of the same width, the mercury must evidently sink as much in the one as it will rise in the other; so that the variations in the height of the column are thence reduced to half the true quantity. A small bason, or semi-circular wooden box, to hold the surplus mercury, was therefore attached to the frame of the instrument; and this construction, with very little change, was adopted, during the course of a century, by the makers of the ordinary barometer. But the syphon barometer itself was afterwards materially improved by having its lower branch blown into a wide bulb for holding the charge of mercury. (See fig. 2. Plate XXXII.) This form of the barometer is not quite accurate, owing to the smallness and unequal shape of the round bulb; but being very convenient for carriage, it has grown into general use, at least for the cheaper and more common sort of instruments.

Barometer of Descartes. As soon as the barometer came to be regarded as a weather-glass, ingenuity was set at work to devise the means of enlarging its scale of variations. Descartes

first proposed a simple method for effecting that object, by combining a mercurial with a water barometer; which arrangement, though subject to imperfection, has led to many of the subsequent improvements. (See fig. 4.) He directed two short barometric tubes to be cemented, the one into the bottom, and the other to the neck of a phial; or, still better, that the tubes should be joined, by the flame of a lamp, to the opposite ends of a wide and regular cylinder. The lower tube, and a portion of the cylinder, were then to be filled with mercury, and above it was to be introduced pure water, reaching to the top of the upper tube, and there sealed close. When this compound tube was inverted in a bason of mercury, it is evident that the columns both of mercury and of water would sink, till their joint pressure became just equal to the superincumbent weight of the external atmosphere. But the variation of this weight would afterwards be indicated chiefly by the large motion of the water; since the mercurial column, spreading out above into a broad surface, must, in any case, experience a very slight difference of altitude. Thus, suppose the cylinder to have eight times the diameter of the upper tube, or a section sixty-four times greater, mercury being 13.6 times denser than water: For each inch of increase of altitude which the ordinary mercurial column gains, the top of the water would be raised in the tube 11.4 inches, its own rise being 11.18 inches, and that of the wide mercurial cylinder only .18 of an inch, yet equal in pressure to 2.4 inches of water. But Descartes, generally satisfied with mere theory and speculation, did not live to see his construction of the barometer carried into effect; and Chanut, the French resident at Stockholm, to whom he had imparted his views, met with such difficulty in the execution of the project, that, after some fruitless attempts, he abandoned it altogether.

Huygens was more fortunate; and succeeded, by dint of perseverance and skill, in constructing the Cartesian barometer. But he had the mortification to find that, in spite of all the pains he could take, the water, after it was relieved from the pressure of the atmosphere by the sealing up of the tube, constantly discharged a portion of air, which collected at the top, and by its elasticity depressed the compound column below its due altitude. Convinced that this source of imperfection is irremediable, he sought to rectify the construction of the instrument, and produced his *Double Barometer*, a form of combination frequently used, especially when the object is rather to make the variations very sensible than to obtain delicate results. (See fig. 5.) He joined a barometric tube of the usual length by the flame of a blow-pipe, to two wide cylinders, the one sealed at the top, and the other annexed likewise hermetically to a tall and narrow tube, open at its extremity; he then bent the thicker tube a little above the lower cylinder, and brought the two branches to be parallel. The instrument being thus formed, he filled the first branch with mercury, and introduced above, in the second branch, some liquid of comparative lightness. Alcohol would, in this respect, answer extremely well, if it were not so liable to waste by evaporation.

Barometer. An alkaline lye, or the deliquescent salt of tartar, which also readily admits of being coloured, was, therefore, on the whole, preferred.

The principle of this construction is evidently the same as in that of Descartes; but the vacuum lying contiguous to the mercury itself, can have no admixture of disengaged air or of aqueous vapour. Since the cylinders are made very much wider than the bore of the annexed tube, the variation of pressure will be produced almost entirely by the change of altitude which the alkaline liquor undergoes, the mercury suffering only a very minute alteration of ascent or descent. The divisions of the ordinary scale will be about tenfold enlarged, if a section of each cylinder should exceed twenty times that of the tube in which the liquor plays.

Its advantages and defects.

A barometer of this construction has decided advantages with respect to the extent of its changes, but still it is not exempt from considerable defects. The moisture on the inner surface of the cylindrical reservoir increases the adhesion of the mercury, and retards its movements. But a much greater source of error proceeds from the influence of heat in extending the volume of liquor contained in that reservoir, and rising into the narrow stem. This instrument, therefore, to a certain extent, blends the indications of the barometer with those of the thermometer, which are essentially different, and can seldom accord.

Hook's Double Barometer.

About the same period, Dr Hook likewise proposed a double barometer, of a similar construction. He afterwards resumed the subject, and with a view to correct the defect of the former arrangement he produced, in 1685, an instrument of a more complex form, but very ingeniously conceived. (See fig. 6.) To the upper end of the open stem, he joined a third cylinder of the same dimensions as the two former, but tapering away to a fine orifice at the top. The principal tube being filled as usual with mercury, extending to occupy the bottoms of both the connected cylinders, he introduced a liquor immediately over the mercury in the second cylinder, rising partly into the stem; above this, again, he poured another liquor specifically lighter and differently coloured, filling up the rest of the stem, and amounting into the third cylinder. By this artificial and delicate combination, the mercury is left perfectly stationary, and all the movements corresponding to the changes of atmospheric pressure, are performed by the counterpoising liquors, and marked by their line of mutual separation. Since the stem or narrow tube remains constantly full, the variation of its pressure must depend on the different proportions of its length occupied by the two fluids. If the weight of external atmosphere should, for instance, increase, the denser liquor will rise, and consequently cause the lighter liquor to contract its column. The action of this compound barometer, being thus produced merely by the difference of the gravity of the two fluids, might, therefore, be augmented indefinitely. Suppose the liquid resting on the mercury to be pure water, and the superincumbent liquid to be olive oil, which is about one-twelfth part lighter; the scale would be enlarged no less than one hundred and sixty-three times, or an

alteration of one-tenth in the altitude of the common mercurial column, would be marked by a motion through 12×1.86 inches, or 16.8 inches. But such a vast enlargement of the scale is far greater than would ever be desirable in practice. It were better, therefore, to introduce next the mercury some fluid which is denser than water. If oil of sassafras were combined with oil of oranges, the divisions of the scale would be augmented only sixty-eight times, and consequently the whole range might not exceed ten or twelve feet. Those oils, however, would move rather sluggishly, especially in cold weather, and might, from their incessant shiftings, during a lengthened period, become insensibly mixed. On the other hand, fluids of distinct characters are seldom free from chemical action; they expand differently with heat, and by coating with other traces the inside of the tube, they are the more apt to retard the motion of the column. In general, the advantage of any very great augmentation of the scale is counterbalanced, as the fluids then work by irregular starts; and the instrument loses in delicacy whatever it has gained in extent of action.

Another method of augmenting the variations of the barometer was invented by the same fertile genius, which has the advantage of uniting great simplicity with tolerable accuracy. (See fig. 7.) Resuming the syphon barometer, he made a small float of iron or glass to rest on the exterior surface of the mercury, and suspended by a slender thread passed round a small wheel or cylindrical axis that carried an index. Though the varieties of the height of the mercurial column are in a tube of this form, reduced to half the ordinary measure; yet, from the great length of the index compared with the diameter of its axis, the divisions on the circumference of the circle in which it travels are much amplified. The little machinery being concealed within the frame of the instrument, the index only is brought into view, protected by a circular plate of glass. Thus fitted up, the whole forms rather a handsome piece of furniture. The *Wheel Barometer*, as it is called, has long maintained its reputation among ordinary observers.

A very simple mode of enlarging the divisions of the barometer is commonly ascribed to Sir Samuel Moreland, the same person who had invented, or perhaps only revived, the *Speaking Trumpet*. (See fig. 8.) It consisted in merely bending the upper part of the tube into a very oblique position. By this plan, however, the scale, which depends on the perpendicular altitude, cannot be augmented beyond three or four times, without incurring evident risk of inaccuracy. This instrument is called the *Inclined* or *Diagonal Barometer*. The form has been sometimes varied by the fancy of artists, who, repeating the inclination of the tube, have occasionally given the upper part a zig-zag appearance.

The most ingenious barometer, filled with mercury only, and yet admitting a scale of any extent, was invented by Cassini and by John Bernoulli, who first gave the description of it in 1710. (See fig. 9.) A wide cylinder is annexed to the top of the main tube, at the bottom of which there is joined at the right angles another long and narrow tube. The mercury, in ascending or descending within the wide cylinder

Barometer. must, therefore, run along this horizontal tube. If that cylinder have a diameter only four times greater than the bore of the tube, the scale of variation will be augmented sixteen times. This instrument is, from its shape, called the *Square Barometer*. It is not found in practice to answer so well as the theory might lead us to suppose. The mercury creeps along the horizontal tube with difficulty, and by desultory advances; and these irregularities increase, as it becomes, from its motion and exposure, covered with dust and partial oxidation.

Conical Barometer.

The simplest of all the barometers, with an enlarged scale, and, at the same time, one of the most ingenious, is the *Conical or Pendant Barometer*, invented and described in 1695, by Amontons, a French philosopher, who being afflicted with total deafness, in consequence of a fever in his infancy, had devoted himself to mechanical contrivances. (See fig. 3, Plate XXXII.) This instrument consists merely of a tube, four feet or more in length, with a bore narrower than ordinary, and tapering regularly to the top. The width at the bottom must hardly exceed three-twentieth parts of an inch, while near the top it may be contracted to about one-tenth. A column of thirty-one inches of mercury being introduced, the tube is gently inverted and held perpendicular; the cohesion of such a narrow column is sufficient to prevent it from dividing and admitting the air, unless it be shaken; but overpowering the atmospheric pressure, it descends till it has contracted into the equiponderant altitude, by passing into a wide part of the tube. To obtain equal divisions on the scale, it is necessary that the tube should have an uniform taper. The most accurate construction of a barometer of this kind is, therefore, attained by forming together two tubes that have even but unequal bores, the longer and narrower one being uppermost. If the width of the upper tube were supposed to be to that of the under one as two to three, the scale would be enlarged three times, since, by descending three inches from the top, and consequently two at the bottom, the column would suffer a contraction of one inch in height.

This species of barometer is thus recommended by its simplicity and its ample range. But the bore of the tube being indispensably narrow, the mercury moves with difficulty, and resists the impression of minute changes of external action. When the conical shaped tube is retained, the instrument is liable to some inaccuracy from the influence of the cohesion of the mercury, which varies with the diameter of the column in different parts of the tube.

Amontons likewise proposed another form of barometer, in which the mercurial column is subdivided among several short connected branches. (See fig. 10.) Suppose the instrument were to have only the third part of the usual height; the first, third, and fifth branches enlarged above and below into very short cylinders, are filled with mercury; and the second, fourth, and sixth branches, which may have their bores narrower, are occupied with some light fluid, or simply with air. If the external pressure should suffer any di-

minution, the three mercurial columns which produce the counterpoise, will each descend and push up the last fluid of the series by their combined effects. It is evident, that, by multiplying those branches, the barometer will have its altitude proportionally reduced. But this construction, though specious in theory, is found to have no practical advantages. The instrument is, from its complication, very difficult to construct; its motions are sluggish, owing to the multiplicity of tubes, and the conjunction of fluids, and they are subject to derangements from the variable influence of temperature. It has, therefore, been generally abandoned.

These different forms of the instrument have been variously modified, and often brought forward with claims of novelty. We may notice, however, the *Sectoral Barometer* proposed by Magellan, in which the mercury is always made to rise to the same high point of the tube, by drawing this less or more aside from the vertical position. The arc they described will indicate the deviation from the perpendicular, and consequently the actual descent of the mercury. But the difference between the vertical and the oblique line is not measured by the inclination merely; it is proportioned to the versed sine of this angle, or nearly to the square of the arc. The advantage of this mode of observing is, therefore, best perceived in small variations of the mercurial column. In the hands of a skilful observer, the best and most accurate barometer, after all, is that of the original construction, with a tube rather wide, and a broad cistern. To apply minute divisions, is decidedly preferable to any enlargement of the scale. The measuring of such divisions has been since rendered extremely easy, by the adaptation of the differential scale—a most valuable contrivance proposed by Vernier, early in the seventeenth century, but strangely neglected long afterwards. This delicate appendage being once adopted, it became the more desirable to improve the sensibility, and regulate the correctness of the indications of the barometer.

The first object was carefully to cleanse the mercury, and to expel any portions of air or moisture adhering to the inside of the tube. The influence of aqueous vapour in depressing the mercurial column had been observed by Huygens; but other more evaporable fluids were afterwards found to occasion, by their presence, a still greater derangement. Homberg having, about the year 1705, washed a tube with alcohol, to remove the impurities from its internal surface, remarked that the mercury introduced into it stood an inch and half lower than usual; a depression which this ingenious chemist was disposed to attribute to the elasticity of the spiritous exhalations collected above the mercurial column; though other academicians, and Amontons among the rest, misled by their Cartesian prejudices, sought to ascribe the effect to the different sized pores of the glass. These anomalies were removed, by heating or rather boiling the mercury in the tube, till it was completely purged of air and moisture, and brought into close contact with the inside of the tube. But a new fact occurred which long puzzled the mechanical philosophers. The tube

Effect of
Moisture
within the
Barometric
Tube.

Barometer.
Luminous
Barometer.

of a barometer, which had been filled with more than usual care, was observed to exhibit a luminous appearance, when moved or slightly agitated in the dark. This curious phenomenon gave occasion to multiplied and prolonged controversies; it was attributed to the subtle matter of Descartes, or ascribed to a native phosphorescence, or a latent fire inherent in the mercury. Our countryman, Hauksbee, in the year 1708, gave the first rational explanation of the fact, by referring it to electricity, which he had just begun to cultivate as a distinct science. It resembles exactly, indeed, the experiment of the exhausted flask, in which an electrical current flashes with a diffuse lambent flame, like the *aurora borealis*, or the *northern streamers*. The friction of the mercury against the inside of the tube excites electricity, while the vacuity, or rather the very attenuated vapour, in which the supposed fluid plays, facilitates its expansion. When the vacuum is rendered very perfect, by the careful and accurate boiling of the mercury, the lambent flashing ceases, for want of a fine medium to conduct and disperse the electrical influence.

Effect of
the width
of the Tube.

The next point to which experimenters were led to direct their attention, was the effect of the width of the tube on the altitude of the mercurial column. Plantade, a lawyer at Montpellier, appears to have been one of the first who remarked that the mercury stands always lower in narrow tubes. This fact he communicated about the year 1730 to Cassini, who was then occupied in the south of France, with carrying on the great trigonometrical survey. But the discrepancies observed by Plantade being unfortunately confounded with other collateral circumstances, were for a time overlooked. In tubes having a narrow bore, the depression of the mercury, however, is very considerable, as may be readily perceived in a small glass syphon, of which the one branch is about half an inch in diameter, and that of the other branch less than the tenth of an inch. Thus, if the narrow tube had a width of only the thirteenth part of an inch, the depression of the mercury would amount to half an inch, which is about the third part of the elevation to which water in similar circumstances would be raised by capillary action. This effect has not been sufficiently examined, but it appears to result from the attraction of the particles of the mercury to each other exceeding their attraction to the surface of the glass. Mercury, in contact with glass, therefore, tends to a spherical form, and always assumes a convex surface within a clean tube. Water and other liquids again manifest an opposite character, the mutual attraction of their particles being less than their adhesion to glass. Accordingly, they spread along a vitreous surface, instead of collecting into drops; and in narrow tubes they mount above the level, and invariably have a concave termination. If the bore be so small as to be reckoned capillary, the depression of mercury is, like the elevation of water, inversely as the diameter; but when the bore has a considerable width, the quantity of depression, depending on the curvature of the surface of the mercury, diminishes proportionally faster, and follows nearly the inverse

Barometer.

duplicate ratio of the diameter. But on the subject of capillary action, we expect, with no small degree of impatience, to see a paper which was very lately communicated to the Royal Society of London, by Mr Ivory, of the Military College at Sandhurst, one of the most original and profound mathematicians that our island has had the honour to produce.

The influence of the predominating attraction of the particles of mercury to themselves, above their adhesion to the sides of a glass tube, has not been considered with so much attention as it demands. Nothing is more common than to remark that the mercury in the barometer is in the act of rising, if it show a convex surface, but about to fall, if it should appear concave. Now, the top of the mercurial column must always remain convex, if the barometer be properly constructed, the tube perfectly clean, and the mercury purged of all impurities. But if the inside of the tube be any how soiled, whether covered with humidity or stained with mercurial oxyd, the metallic fluid will adhere so obstinately to the glass, as to lose its convexity, and to subside into a flat surface, or even sink into a concavity, like water and other liquids. Hence the danger of boiling the mercury too long in the tube, as it becomes partially oxydated, and the thin crust so formed not only suspends the column higher, but obstructs the freedom of its motion. The same effect is produced by greasing the inside of the tube. Some respectable authors, from not attending to these facts, have hastily inferred that the convex appearance which mercury assumes in the barometer was merely accidental, and consequently removed by a more complete boiling and purification.

Pure Mercury has always a convex surface.

In the case of tubes having wide bores, the depression of the mercurial column may, without any sensible error, be disregarded. According to the accurate experiments made by Lord Charles Cavendish, and published by his son, the celebrated Mr Cavendish, the quantity of depression is only the 200th part of an inch in a tube of 6-10ths of an inch in diameter, the 28th part of an inch in a tube of 3-10ths diameter, and the 15th part of an inch in a tube of 2-10ths diameter. Wide tubes ought, therefore, to be preferred in the construction of barometers, both on account of the facility with which the mercury moves in them, and the smallness of its depression. The only circumstance to overbalance these advantages, would be the necessity and inconvenience of having a very large cistern. A quarter of an inch may be reckoned a good width of tube, and the corresponding depression is only the twentieth part of an inch.

Quantity of depression in different Tubes.

In the syphon barometer, if both branches have the same diameter, the action is exerted on opposite sides, and, therefore, the effect of depression becomes entirely lost. For accurate purposes, this original form of the instrument has been again resumed, and the inconvenience arising from the large variation of the lower level entirely obviated by an ingenious contrivance introduced about forty years since. This consists in the application of a leathern bag, instead of a wooden or ivory cistern, to hold the surplus mer-

Application of a leathern Bag.

Barometer. cury. Besides the barometric tube, there is placed adjacent to it another short one of the same width, communicating with the mercury contained in the bag, which being pressed by turning a screw below, is, at each observation, brought exactly to the same mark. The external atmosphere readily acts through the substance of the leather, but the mercury, from the powerful cohesion of its own particles, cannot be squeezed through the pores of that casing without violent compression. The addition of a bag within a cylindrical box, omitting the lower tube, likewise renders the barometer easily portable; since, for safe carriage, the mercury can be screwed up tight, to fill the whole cavity of its tube, but, on turning the screw again, the column will subside and rest on a broad base.

Effect of Heat on the Barometer. The last object which required nice observation, was to estimate the effect of heat in dilating the mercury, and consequently increasing the altitude of the equiponderant column. This correction could not be made with any sort of accuracy previous to the application of the thermometer, which, though invented half a century earlier than the barometer, was yet more than another half century in arriving at perfection. Hero, a mechanical philosopher, who flourished at Alexandria about 130 years before Christ, has described in his *Spiritualia* a sort of huge weather-glass, in which water was made to rise and fall by the vicissitudes of day and night, or rather the changes of heat and cold. This machine had for ages been overlooked, or merely considered in the light of a curious contrivance. But Sanctorio, the inventor of the famous statical balance, a very learned and ingenious Italian physician, who was long professor of medicine in the university of Padua, and had laboured to improve his art by the application of experimental science, reduced the hydraulic machine of Hero into a more compendious form, and thus constructed, about the close of the sixteenth century, the instrument since known by the name of the *air-thermometer*, which he employed with obvious advantage to examine the heat of the human body in fevers. Some years afterwards, a similar instrument was contrived, perhaps without any communication, by Drebbel, a very clever and scheming Dutch artist, who visited London in the reign of James I., and introduced the knowledge of that instrument into England.

Invention of the Thermometer.

But this air-thermometer was evidently of the same nature with what has been since called the manometer; it could measure only the dilatation or augmented elasticity of the air confined within its bulb, whether occasioned by heat or the diminution of external pressure. It was, therefore, considered merely as a weather-glass, indicating the state of the atmosphere; nor could its blended impressions, which might separately affect both the thermometer and barometer, be then distinguished. Had it been more closely studied, it must have led, by another path, to the discovery of the latter. But those irregularities to which the air-thermometer was hence subject appear to have created such doubts respecting the accuracy of the instrument, as occasioned its being neglected long afterwards.

The same country, however, which had given birth to the thermometer, began its improvement. After the principle of the barometer was established, the members of the Academy del Cimento, founded at Florence in 1667, and supplied with liberal funds by the Grand Duke of Tuscany, had, among other interesting physical researches, resumed the application of the thermometer; and instead of air, they substituted alcohol or spirit of wine, another very expansible fluid not affected by pressure, while they attached to the tube a scale graduated on a regular plan, though directed by no very precise measures. The instrument so constructed, but somewhat varied in its form, being copied by Italian artists, was dispersed over Europe under the name of the *Florence Glass*. From its careless execution, however, in the hands of itinerant venders, this thermometer, or rather thermoscope, appears never to have obtained an established reputation.

The great object was to bring thermometers to an exact correspondence. It was expedient, therefore, not only to select a proper fluid, but to adopt a uniform and consistent scale. Alcohol, linseed oil, and mercury, had been successively tried. The graduation was at first drawn from the temperature of cellars and deep caves, which, indicating the natural heat of the globe, had long been considered invariable; but more enlarged experience discovered the inaccuracy of that supposition, and showed the mean temperature to be materially modified by the latitude of the place, and its elevation above the level of the sea. Congelation, or rather the inverted process, the thawing of ice, or the melting of snow, was then found to remain fixed; a most important fact, which had been first noticed by Gårické, but overlooked till a considerable time afterwards. A stationary point was hence obtained, from which to commence the thermometer scale. But different modes were pursued for determining the divisions. Amontons, reverting to the air-thermometer in spite of its acknowledged defects, found that the elasticity of air compressed in the bulb, and able at the temperature of melting snow to support a column of mercury fifty-four inches high, was capable of raising this to seventy-eight inches, at the heat of boiling water; and he seemed contented in framing a rude standard, with merely dividing the intermediate space into inches and half-inches.

But about the same, or nearly at the beginning of the eighteenth century, Newton himself cast a keen though rapid glance on the subject of heat, and proposed a thermometer of a much simpler and more elegant construction. Having adopted linseed oil as a fixed and uniform substance, capable of great dilatation, he discovered by experiment, that distinguishing the capacity of the bulb into ten thousand equal parts, the liquid expanded 256 parts, from melting snow to blood heat, and 725 parts to that of boiling water. These numbers, however, being inconveniently large, he reduced them somewhat more than twenty times, adopting 12 and 34 as the proportional divisions on his scale. But oil, being so viscid a substance, was found to trail and collect on the inside of the tube; and this

Barometer. thermometer, though constructed on a right principle, never came into general use.

Röemer. Röemer, the Danish astronomer who made the first discovery of the progressive motion of light, was the first who proposed mercury as the fittest fluid for thermometers; and Halley and Amontons remarked about the same time, that it expands uniformly with heat, and remains nearly stationary at the point of boiling water. On this principle, Delisle, of St Petersburg, constructed, in 1733, a mercurial thermometer, with a descending scale, the distance from freezing to boiling water occupying 153, or, in round numbers, 150 divisions, of which the bulb itself contains 10,000. A more ingenious method, but perhaps too refined, for graduating thermometers, was proposed by Renaldini in 1694. It consisted in adopting the scale in the successive temperatures produced by mixtures in the different proportions of twelve parts of water at the moment of thawing and of ebullition. This suggestion led to a very important inference, since it proved that mercury expands uniformly with equal additions of heat, while alcohol swells constantly in a rising progression. But the capital improvement of the thermometer was effected by the skill and perseverance of Fahrenheit, whose name has remained justly attached to the instrument. This ingenious person, originally a merchant at Dantzic, who had the misfortune to fail in business, was induced, by his taste for mechanics and chemistry, to have recourse to the manufacture of thermometers, as the means of gaining a slender livelihood. But not meeting with sufficient encouragement at home, he removed, about the year 1720, to Holland, the great emporium of the arts, and fixed his future residence at Amsterdam. He now preferred mercury to alcohol for filling his thermometers; and, adopting the division of the bulb into 10,000 parts, he reckoned $\frac{64}{100}$ of them as the expansion between freezing to blood-heat; and $\frac{32}{100}$ as the contraction from the same point to what he considered as extreme cold, or that produced by the mixture of salt with snow. These numbers were extremely convenient, being found by a repeated bisection. With respect to the heat of boiling water, Fahrenheit discovered the important fact, that it varies with the state of atmospheric pressure. Taking the mean, however, he reckoned 180 degrees from freezing to ebullition, and, therefore, marked this point at 212 on his scale. The thermometer owes its improvement to Celsius, professor at Upsal, who in 1742 placed the commencement of the scale at congelation, and divided the interval thence to boiling water into an hundred degrees, extending such a portion downwards as might be wanted: This centesimal thermometer is exactly the same as what the French have since called the *centigrade*, which, from its fitness and simplicity, deserves to be universally adopted.

The thermometer having been thus carried by successive steps to perfection; it was found by delicate experiments, that, between the points of boiling and freezing, the expansion of mercury amounts to the fifty-fourth part of its bulk, or that it acquires, for each degree of heat, an increase of volume amounting to the 5412th part on the centesimal

Delisle's Thermometer.

Renaldini.

Fahrenheit's Thermometer.

The Celsius or Centigrade Thermometer.

Correction of the Barometer as affected by Heat.

scale, or the 9742d part on the scale of Fahrenheit. A correction, therefore, on the height of the mercurial column in the barometer, becomes necessary according to the changes of temperature which it undergoes. In this climate, the extreme variation arising from that cause will seldom exceed two-tenths of an inch. But if the barometer be suspended in a room, kept at an agreeable temperature, the error occasioned by the expansion of the mercury may, in ordinary cases, be disregarded, since it will scarcely amount to the twentieth part of an inch.

Barometer.

Since the barometer marks the condition of the distant atmosphere, and intimates those internal alterations which are generally connected with the change of the weather, it is particularly valuable at sea, by forswarning the mariner of the approach of a storm. But an instrument of the ordinary construction would not answer this purpose, the agitation of a vessel on a tempestuous ocean being such as will not only throw the ponderous mercurial column into violent oscillation, but communicate those sudden shocks which must infallibly break the tube. Various attempts have accordingly been made to obtain a *Marine Barometer*, exempt from risk, and yet sufficiently sensible to the variations of the atmosphere. The conical or pendant barometer being, from the narrowness of its bore, rather sluggish, was first recommended for that purpose, though never adopted into practice. About the beginning of the eighteenth century, Dr Hook and Amontons severally proposed to employ for a barometer on board ship, the manometer or air-thermometer. To obviate the derangement arising from the influence of heat, there was to be placed beside it a spirit-of-wine-thermometer, with a ball so large as to give expansions equal to those of the portion of air confined within the bulb. The difference between the two adjacent columns of liquid would therefore measure the variation of external pressure. But to procure such a nice adaptation would prove so extremely difficult in practice, that most probably this instrument was seldom or ever actually constructed. Besides, the liquid column of the manometer, though light and narrow, would yet be much shaken by the rolling and pitching at sea. Notwithstanding these weighty objections, however, this compound manometer was tried in England, mercury being employed as the fluid both of expansion and pressure, and various adjustments applied by means of a complex machinery.

An ingenious and very substantial kind of marine barometer was about twenty years since recommended by Blondeau, one of the professors of the naval academy at Brest. (See fig. 11, Plate XXXII.) It consisted of an iron tube, bent below into a syphon, and filled carefully with mercury, which carried a float. For this purpose, a musket-barrel, about three feet long, was chosen, having a very smooth and even bore, and an iron breech closely welded to it, instead of being soldered with brass, which might become corroded by the action of the mercury. The lower end of the tube had a collar of leather, to which was screwed a piece

Marine Barometer.

Blondeau's Marine Barometer.

Barometer. of iron, perforated through its whole length, and bent into an arch, having screwed likewise, with a collar of leather at its other extremity, a vertical cylinder of iron, four inches high, and of the same bore exactly as the tube. The contracted aperture at the end of the tube, not being exactly in the middle, was not always opposite that of the arch; and, therefore, by turning it occasionally aside, the communication could be contracted at pleasure, or even obstructed entirely. The cylindrical appendix was tapered at the top to a narrow orifice, through which an iron wire, attached to a small ivory float, had been introduced. To prepare this instrument for action, the mercury was first boiled in the tube; then the arch, filled with hot mercury, was screwed to the end, the cock opened, and the surplus mercury allowed to flow over; next the vertical piece, with its float, was screwed on, and a little mercury added, to give it due play. The origin of the scale was to be determined from the comparison with another good barometer of the ordinary construction; but, owing to the equality of the bores of the opposite tubes, the divisions were only half the usual size, or the inches were exhibited by half-inches.

This species of barometer is certainly free from all sort of risk, while the facility which, by means of turning the arch, it affords in checking the ascent and descent of the mercury, prevents in a great measure the oscillations of that fluid. If the instrument were properly suspended, therefore, its indications would be tolerably steady and regular. The chief objection to it consists in the diminutive range of its scale.

In every marine barometer, the main object is to give steadiness to the mercurial column, by retarding its motion in the tube; in short, to imitate the equalizing effect of the fly in mechanics. One form of construction was, instead of the cistern below, to annex a spiral tube composed of a number of horizontal convolutions. Passemont, an ingenious Parisian artist, about the year 1758, improved on this idea. He twisted the barometer tube near the middle, at least twice round, and joined to its upper end a wide cylinder. But more effectually to prevent all irregular oscillations, he took a tube with a very narrow or capillary bore, and contracted it below, while he annexed a wide cylindrical piece at its other extremity. The only thing wanted now to the perfection of this instrument, was to devise a mode of suspending it that should soften the jerks, and allow it generally to maintain a vertical position. Our English artists have, by repeated trials, at last succeeded in surmounting all the difficulties. The marine barometer, manufactured by Mr Cary of London, (*See fig. 12, Plate XXXII.*) is one of the most approved kind. It consists of a capillary tube, about twenty-seven inches long, with a bore scarcely exceeding the thirtieth part of an inch, but terminated by a cylinder four or five inches high, and nearly three-tenths of an inch in diameter. It is suspended by a spring and jimbols, near the top at a certain point, which in each case is discovered by actual trial. By making the suspension lower, it is found, that the agitation of the barometer will cause the mercury to rise a little; while, by pla-

cing the suspension higher, the mercurial column suffers always some depression. The reason of this curious observation is not well explained. It probably results from the different centrifugal tendencies communicated to the opposite portions of the columns. The swinging of the instrument would evidently augment the pressure of the upper portion of the column, while it diminished that of the under portion. But this lower portion, being longer than the other, its tendency to descend would be proportionally so much greater. About the point of suspension, however, the opposite effects of the centrifugal tendencies are balanced, since the superior force being employed to set in motion a narrower column, the reflux and efflux of the mercury in the upper cylinder must be preserved nearly equal.

Marine barometers, thus improved, are now very generally used, and with great benefit to the public service, on board ships of war and Indiamen. To facilitate the keeping of a register of barometrical observations, the meritorious and indefatigable Mr Horsburgh, hydrographer to the East India Company, has lately published a set of engraved ruled sheets, adapted for the convenience of navigators. In these plates, the height of the mercury, from twenty-seven to thirty-one inches, is represented, in inches and tenth parts, by horizontal lines, while each successive day has a space apportioned to it by vertical bars. The state of the barometer at every observation is marked with a dot, and these dots being afterwards connected together, exhibit an irregular waved line, stretching across the sheet, and indicating the series of the changes of the weather. At the lowest points, from which the curve again returns, a gale generally follows. From the observations made off the Cape of Good Hope, during the month of May 1815, by an ingenious and active young officer, Captain Basil Hall, of his Majesty's sloop *Victor*, it appears that whenever the mercury fell to 29.60 inches, a storm ensued; the column always rose when the gale abated, and when it reached near thirty inches, the weather became fair. Those gales often came on suddenly, without any visible change in the aspect of the sky, but the marine barometer never failed to give warning of their approach.

To explain the cause of the variations of the barometer, has long perplexed philosophers. Many hypotheses have at different times been advanced on the subject; but it would be a mere waste of time, to make any detailed recital of such crude and unsatisfactory attempts. The various and often imaginary effects of vapours of heat and winds have been employed in framing an explication of the changes of the atmosphere. The fact that the mercurial column generally falls before rain, seemed at complete variance with the intimation of the senses, it being a notion universally prevalent, that the air is heavier when the sky appears lowering and overcast; another proof, if it were wanted, how fallacious are all current opinions in matters of science.

Leibnitz, fancying he had discovered a new principle in hydrostatics, endeavoured, by a sort of metaphysical argument, to demonstrate that, though a body

Barometer. adds its own weight to the pressure of a fluid in which it is suspended, yet it will cease to be ponderous in the act of falling. This alleged principle will not, in the actual state of science, be thought to require any serious refutation; nor, were it even admitted, would it be found at all adequate to the explication of the phenomenon, since the weight of moisture precipitated from the whole body of atmosphere could never, by the absence of its pressure, occasion a diminution of the tenth part of an inch in the altitude of the mercurial column.

Hauksbee's Experiment.

Dr Halley and Mairan sought to account for the depression of the barometer before a storm, to the withdrawing of the vertical pressure of the atmosphere, when borne swiftly along the surface of the globe by a horizontal motion. This hypothesis at first sight appears very plausible, and might seem farther confirmed by a noted experiment which most authors have admitted without due examination. Hauksbee, a skilful and ingenious experimental philosopher, about the year 1704, placed two barometers, about three feet asunder, with their naked cisterns in two close square wooden boxes, connected by a horizontal brass pipe; one of these boxes had, inserted at right angles, an open pipe on the one side, and a second pipe terminating in a screw, on the other side; to this end he adapted a strong globular receiver of about a foot in diameter, which had been charged, by injection from a syringe, with three or four atmospheres; then suddenly opening the stop-cock, and giving vent for the escape of the air through the box and over the surface of the included cistern, the mercury sunk equally in both the barometers more than two inches.

Its Fallacy.

This elegant experiment might be deemed entirely conclusive, if a minute circumstance, on which the success really depends, had not unfortunately been overlooked. It will be perceived from the inspection of the figure which Hauksbee has given, that the exit pipe of the box was considerably wider than the pipe which conveyed into it the stream of air. This fluid, escaping from compression, would, therefore, be carried by its elasticity as much beyond the state of equilibrium; while the width of the orifice, by facilitating its emission, would allow the portion occupying the box and the connected reservoir to preserve its acquired expansion. If the pipe of discharge from the box had been much narrower than the other, an opposite effect must have taken place; for the air accumulated over the cistern, not finding a ready vent, would remain in a state of condensation. This curious fact is another of the many instances which might be cited to show the great delicacy and circumspection required in performing philosophical experiments.

The same results, however, can be exhibited by a very simple apparatus. Let a small box, or rather a glass ball, have a short narrow tube inserted in the one side, and another wide tube opposite to this, with a cross slider of brass, for contracting the orifice at pleasure; and, to the under part of the ball, join a long perpendicular tube, bent back like a syphon to more than half its height and containing a double column of water. Now, blow through the narrow tube into the cavity of the ball, while the orifice of

emission is quite opened, and the liquid will rise several inches in the long stem; but, still continuing the blast, let the orifice be gradually contracted, and the column will first descend to its ordinary level, and then sink considerably below it.

Barometer.

The fall and rise of the mercury in the barometer must evidently be occasioned by some corresponding reduction or accumulation of the atmosphere at the place of observation. Whatever augments the elasticity of the air will cause part of the incumbent fluid to evade and leave for the time a diminished vertical pressure. The efflux of wind might also produce a temporary reduction of the atmospheric column. But the real difficulty consists in explaining why the variations of the barometer should be greater in the high latitudes than between the tropics, and why they so much exceed in all cases the quantities which calculation might assign.

Causes of the Variation of the Barometer.

The influence of heat will account for the semi-diurnal variations of the barometer which are observed, especially within the torrid regions. From ten o'clock in the morning till four in the afternoon, the mercury generally falls; but, after that hour, it rises again, till ten o'clock at night, when it drops till four in the morning, and then mounts till ten o'clock in the forenoon. These regular changes, which amount to about the five-hundredth part of the whole atmospheric pressure, depend on the prevalence of the alternating land and sea breezes, occasioned by the diversified action of the sun's rays upon the earth and water. The accumulation of air is greatest at four o'clock in the morning and evening, and the mercury then attains its highest point; but it sinks lowest at ten o'clock in the morning and evening, when the incumbent mass has been the most reduced.

A similar reason will explain the effects of the northerly and easterly winds, in elevating the mercury of the barometer in our climate. A chill air, with enfeebled elasticity, is thus accumulated, and exerts a predominant pressure.

The augmented elasticity communicated to the air by the action of heat or the presence of humidity, and the reduction of the incumbent mass by the efflux of winds, have each their distinct influence, in disturbing the equilibrium of atmospheric ocean. But the effects, particularly in the high latitudes, much surpass the regular operation of those causes. The only mode, perhaps, of removing the difficulty, is to take into consideration the comparative slowness with which any force is propagated through the vast body of atmosphere. An inequality may continue to accumulate in one spot, before the counterbalancing influence of the distant portions of the aerial fluid can arrive to modify the result. In the higher latitudes, the narrow circle of air may be considered as, in some measure, insulated from the expanded ocean of atmosphere, and hence, perhaps, the variations of the barometer are concentrated there, and swelled beyond the due proportion. We content ourselves with throwing out this hint at present, but hope to be able to resume and discuss the subject at some length under the article CLIMATE.

(D.)

R

BAROMETRICAL MEASUREMENTS.

Barometrical Measurements.

It was remarked in the preceding article, that the decisive experiment by which Pascal established the reality of atmospheric pressure, had likewise suggested to this ingenious philosopher the method of determining the elevations of distant points on the surface of the globe. But the first attempts were very rude, proceeding on the inaccurate supposition that the lower mass of air is a fluid of uniform density. Different authors estimated variously from eighty to ninety feet as the altitude, which corresponds to a variation of the tenth part of an inch in the mercurial column. The Torricellian tube or cane, as it was then called, was, on its first introduction to England, carried accordingly to the tops of mountains, or conveyed to the bottom of pits and mines, or even let down to great depths in the sea.

Sinclair.

Among those experimentalists who laboured most assiduously in the study and application of the barometer in this part of the island, we should mention George Sinclair. This ingenious person had been Professor of Philosophy in the University of Glasgow, but seems to have conscientiously resigned his office soon after the Restoration, rather than comply with that hated episcopacy which the minions of Charles II. had forced upon the people of Scotland. He then retired to the village of Tranent, not far from Edinburgh, and was employed as a practical engineer, in tracing the levels of coal-pits, in directing the machinery employed in the mines at Leadhills, and afterwards in the great undertaking of conducting water from the heights of the Pentlands to supply the northern metropolis. Though not a profound mathematician, he was skilled in mechanics and hydrostatics, and possessed no small share of invention. Sinclair is said to be the first who applied to the mercurial tube the name of *baroscope*, or *indicator of weight*, the more definite appellation of *barometer*, or *measurer of weight*, not having been appropriated till many years afterwards. During his excursions in 1668 and 1670, he employed that instrument to measure the heights of Arthur's Seat, Leadhills, and Tinto, above the adjacent plains. He followed the original mode of using a tube

sealed at the top, with a paper scale pasted against the side, which he carried to the top of the mountain, where he filled it with mercury; and, inverting it in a bason, he noted the altitude of the suspended column, and repeated the same experiment below; a very rude method certainly,—but no better was practised in England during the succeeding thirty years.

In a small scarce tract, printed in 1688, and bearing the quaint title of *Proteus bound with Chains*, Sinclair gives some judicious remarks on the variations of the barometer, considered as a weather-glass, and delivers very sound opinions, on the whole, respecting the causes of the chief meteorological phenomena. In a postscript to that piece, he proposes a most efficient and ingenious method of weighing up wrecks from the bottom of the sea. It consisted in employing two large arks, or square wooden boxes, fastened to the sides of the ship, and charged with air carried down to them by a succession of inverted casks, open at the lower end. An ark of a cubical shape, and twenty feet in every dimension, the smallest which he mentions, would, as he computes, have a buoyancy equivalent to 448,000 pounds Troy. It is remarkable that the celebrated Mr Watt always employs this very mode, using a large gazometer, floating in a pond dug in the court of his manufactory, and charged gradually by the action of bellows, for raising the ponderous engines constructed at Soho, and lifting them over his walls into the boats, which are stationed to receive them in the adjacent canal.*

In all the computations hitherto made from different altitudes of the barometer, the air was considered as an uniform fluid; no regard being had to the gradual diminution of density which must evidently take place in ascending the atmosphere. To estimate the effect of that gradation, it became requisite previously to determine the actual relation subsisting between the density of the fluid and its elasticity. This was first ascertained in England by Townley, who inferred from some experiments of Boyle, that the elastic force which the air exerts is exactly propor-

Barometrical Measurements.

Relation of the Air's Density and Elasticity.

* Sinclair was author of a well-known little book, entitled, *Satan's Invisible World Discovered*, which, at a former period, was sold at all the public fairs in the country, and devoured with eagerness and dismay by the Scottish peasantry. In a quarto volume, on *Hydrostatics, and the Winking of Coal-mines*, printed in Holland, and published by subscription in 1672, he digressed so widely from his subject, as to insert *A True Relation of the Witches of Glenluce*. But this was the folly of the age, which several of the most learned men had not been able to escape. It is painful to observe, that James Gregory, the inventor of the reflecting telescope, who, although endowed with talents of the highest order, yet appears to have had a keen temper, and to have imbibed an hereditary attachment to royalism and episcopacy, should have stooped to attack an unoffending and less fortunate rival. He wrote a little tract against Sinclair's *Hydrostatics*, with the title of the *Art of Weighing Vanity*, and under the thin disguise of Patrick Mather, archbeadle to the University of St Andrew's. It is a piece full of low scurrility, and memorable only for a very short Latin paper appended to it, containing the series first given to represent the motion of a pendulum in a circular arc. In the British Museum, there is a letter of Gregory to Collins, the secretary of the Royal Society, boasting of his project, and soliciting information, with which to overwhelm the poor author. But with all his eagerness to hunt down Sinclair, he never touches on the strange episode of the witches of Glenluce. What a picture of times approaching so near our own!

Barometrical Measurements.

tional to its density. A similar conclusion was about the same time drawn by Mariotte, a French philosopher, from a still better series of experiments. Following out this very simple law, he thought of computing heights from barometrical observations, by the rules usually employed in constructing tables of logarithms; and had, therefore, obtained some glimpses, no doubt by a sort of conjectural process, of the remarkable result, that the density of the atmosphere decreases in a geometrical progression, corresponding to the elevations taken after an arithmetical one. But seemingly not aware of the importance of the principle at which he was pointing, Mariotte immediately deserted it; and calculating from a repeated bisection of the column of air between the two stations into successive horizontal strata, he contented himself with interpolating the densities according to a harmonic division, which he next abandoned for the simplicity of a series with equal differences. This able experimenter hence only sketched out a mode of investigating the problem of barometrical measurements, without arriving at any very definite or consistent rule of solution.

Relation of Atmospheric Density and Elevation.

In 1686, the ingenious and active philosopher Dr Halley resumed the subject, and discovered the law that connects the elevation of the atmosphere with its density; of which he gave a clear demonstration, derived from the well known properties of the hyperbola referred to its asymptotes. Since the height of the mercury indicates the pressure, and consequently the elasticity of the external air, it must be proportioned likewise to the density. Wherefore the breadth of a given mass of air, or the thickness of a stratum which corresponds to a certain portion of the mercurial column, will be inversely as this altitude. Let O be the centre of a rectangular hyperbola, of which OA and OB are the asymptotes; and conceive the distances OA and OB to represent the heights of the mercury at two stations. The perpendiculars AC and BD, which are reciprocally as OA and OB, must hence express the relative thickness of strata corresponding to

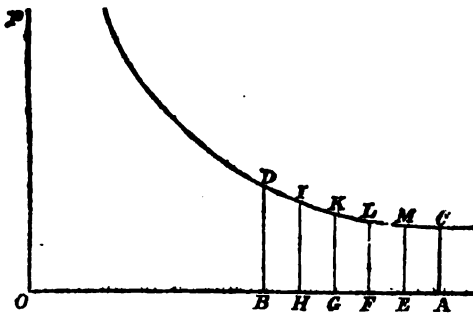

equal portions of the barometric scale. Divide AB into a multitude of equal segments, and erect the perpendiculars EM, FL, GK, and HI. The intercluded spaces, from AC to BD, will denote the successive thickness of the series of strata into which the whole mass of air between the two stations is subdivided. Consequently the aggregate or mixtilineal space DBAC, which is proportional to the logarithm of the ratio of OB to OA, will express the difference of atmospheric elevation when the mercurial column mounts from B to A. Taking equal

ascents, therefore, in the atmosphere, the corresponding densities must form a decreasing geometrical series.

Barometrical Measurements.

Rule Deduced.

To apply this elegant theorem, Dr Halley availed himself of the best experiments which had been performed to determine the relative densities of air, water, and mercury. In different trials made near the earth's surface, it was found, when the barometer stood at 29½ inches, that the air is 840 852, or even 860 times lighter than water. Taking round numbers, therefore, and assuming the specific gravity of mercury to be 13½, he reckoned $800 \times 13\frac{1}{2} \times 80 = 10,800$ inches, or 90 feet, as the altitude of an atmospheric column which, near the surface, would exert a pressure equivalent to that of an inch of mercury. For the coefficient, which answers to the actual constitution of the atmosphere, Halley should have taken the thirtieth part of .4342945, the modulus of the common system of logarithms, or .0144748. But he proceeded less directly, having satisfied himself with taking the arithmetical mean between the differences of the logarithms of 29 and 30, and of those of 30 and 31; a compensation of errors, which gives .0144765, hardly deviating from the former. Hence he gave this simple analogy for computing the heights of mountains by the barometer; as the constant number .0144765 is to the difference between the logarithms of the barometric columns at the two stations, so is 900 feet to the elevation required. The result of this operation is evidently the same as if the logarithmic difference had been multiplied by the number 62170; a very tolerable approximation at all seasons for a northern climate, and quite accurate, indeed, if the mass of intervening air had a medium temperature of 46° by Fahrenheit's scale. Dr Halley supposed that the observations themselves might, from the influence of heat, differ about the fifteenth part between summer and winter. But the thermometer was still so imperfect an instrument, that it could not be applied with confidence in correcting such variations.

The principle which Halley thus investigated might be derived from a simpler process. Conceive the atmosphere to be divided into a multitude of equally thin horizontal strata, it is obvious that each successive stratum would, to the pressure of the superincumbent stratum, add its own weight, which being as its density or elasticity, is therefore proportioned to the collective pressure; and, consequently, those densities will continually increase in going downwards, exactly in the same way, and after a like progression, as money accumulates at compound interest, where a constant portion of the aggregate fluid is regularly joined to the capital. Such, in fact, is the distinguishing character of a geometrical progression, that the increase or decrease of each succeeding term is always proportioned to the term itself. The logarithmic curve is hence the best adapted for exhibiting the relations which connect the densities with the elevations in the atmosphere; the axis of the curve expressing the elevation, while each ordinate represents the corresponding density of the stratum of air. It being a fundamental property of the logarithmic curve, that every subtangent applied to it has the same length, the exact determination of this in the case of our atmosphere, is

Otherwise Investigated.

Barometrical Measurements.

the only thing wanted for the final solution of the general problem.

Eleven years after Dr Halley had given his rule for barometrical measurements, this philosopher had an opportunity of applying it to discover the height of Snowdon in North Wales. He found that the barometer which stood at 29.9 inches on the sea-shore near Caernarvon, fell a few hours after, when planted on the summit of the mountain, to 26.1 inches, the altitude having been ascertained previously by a trigonometrical observation to be 1240 yards.

Newton's General Solution.

The year 1687 is memorable as the date of the first publication of the *Principia*, which was drawn up chiefly at the urgent request of Halley, from disjointed materials that had lain a considerable time in the author's hands. In that immortal work, Newton resumed the problem of the gradation of atmospheric density, and solved it in that general way which suited his penetrating genius. He demonstrated that, supposing the particles of air, like other bodies, to have their weight or gravitating tendency diminished as the squares of their distances from the centre of the earth, if those distances be taken in harmonic progression, the corresponding densities of the atmosphere will form a geometrical one. But since the diminution of attraction at the greatest height we are able to reach, amounts only to the two thousandth part of the whole; this difference is too minute to be admitted into practice; and the simpler law first established by the sagacity of Halley may be deemed sufficiently accurate for every real purpose.

Newton has given a sort of geometrical solution of the problem. But a more precise, and, in this case, a clearer investigation, is obtained by help of the symbols of the integral calculus. Let x and x' express the altitudes of two strata of atmosphere, and y and y' the corresponding densities, the radius of the earth; suppose farther, that e represents the altitude of the equiponderant column which measures the elasticity of the air. Since the density of the air depends on the incumbent pressure, its decrement must evidently be proportional to the weight of each superadded minute stratum, or to the density of this stratum multiplied into its thickness and power

of gravitation. Whence $-edy = ydx\left(\frac{r}{r+x}\right)^2$;

or $-\frac{edy}{y} = \frac{r^2 dx}{(r+x)^2}$, of which the complete integral

is $e H \text{ Log. } \frac{y'}{y} = \frac{r^2}{r+x} - \frac{r^2}{r+x'} = \frac{r^2}{r+x} \cdot \frac{x'-x}{r+x'}$.

If r be regarded as indefinitely great in comparison of x , the expression will pass into $e H \text{ Log. } \frac{y'}{y}$

$= x' - x$, which is only the common formula.

Application of the Thermometer.

Little seemed wanting, therefore, to complete the practice of barometrical measurements, but the application of the thermometer, to correct the results. This instrument, however, advanced slowly to perfection, and more than forty years yet elapsed before it came into current use. Some of the continental philosophers likewise, biassed, perhaps, by a secret jealousy of the superiority which England had acquired in science, began to throw out doubts re-

specting the reality or accuracy of the law of geometrical progression in the atmosphere. Daniel Bernoulli, a man of candour on the whole as well as as ingenuity, but who, with some proneness to speculative reasoning, had imbibed unfortunately many of the prejudices of the Cartesian and Leibnitzian schools, proposed in his capital work, the *Hydrodynamica*, which came out in 1736, certain vague hypotheses regarding the constitution of the atmosphere, as deduced from certain internal motions attributed to its component strata. The specious results of those calculations led him hastily to deviate from the principle of the geometrical progression of density in the upper regions. In this departure he was followed by Cassini and Horrebow, who concluded from some partial observations they had made, that the barometer, in its indications of atmospheric pressure, is subject to irregularity; and that, near the surface of the earth, it obeys a different law from what it obtains at great elevations. A strong light, however, was thrown upon the subject in 1753 by Bouguer, an able mathematician, and a very skilful and ingenious observer, who, with other academicians, had been employed for several years in measuring a degree of the meridian along the stupendous ridge of the Andes. From the comparison of more than thirty distinct observations, he deduced a simple and elegant rule for computing heights by means of the barometer. It is, that the difference between the logarithms of the mercurial columns at the two stations being diminished by one-thirtieth part, and the decimal point shifted four places to the right, will express the required elevation in *toises*. Since the English was to the French foot nearly as fifteen to sixteen, the rule would be accommodated to our measures, and the result expressed in feet, if the logarithmic difference were augmented by the thirtieth part, then multiplied by six, and the decimal point thrown back four places; or, what is the same thing, if that logarithmic difference were multiplied at once by 62,000. But Bouguer imagined, that this rule would not hold exactly in Europe, or in the lower regions of the torrid zone; and to explain the deviation, he had recourse to the forced supposition that the particles of air possess different degrees of elasticity. Lambert, a philosopher of great originality and penetration, afterwards published some excellent remarks on the comparison of barometrical measurements. But no material progress was made till 1755, when M. de Luc of Geneva resumed the subject, and carefully combined experiment with observation. For the space of upwards of fifteen years, he prosecuted his inquiries with diligence and perseverance, aided by the peculiar advantages of local situation, in a city abounding with skilful artists, and seated in the neighbourhood of lofty mountains. The discrepancies which had hitherto created so much embarrassment, proceeded mostly from the inattention of observers to the disturbing influence of heat, and particularly its effect in expanding the air, and consequently augmenting the elevation due to a given difference of atmospheric pressure. De Luc's first object was to improve the thermometer of Reaumur, which, though greatly inferior to that of Fahrenheit, had been adopted in France and the adjacent parts of the continent. Having ascertained that mercury has

Barometrical Measurements.

Bouguer.

De Luc.

Barometrical Measurements.

Barometrical Measurements.

the valuable property of expanding equally with equal additions of heat, he substituted that metallic fluid for spirit of wine, but retained its arbitrary and inconvenient scale of 80 degrees between the points freezing and boiling water. He next examined the dilatation of air at different temperatures, and corrected those results by numerous observations made on the mountains of Savoy, and the mines of the Hartz, in which the barometer was combined with the thermometer. The formula which he thence deduced for the computation of barometrical measurements was, in 1772, published in his *Recherches sur les Modifications de l'Atmosphere*, and seemed to draw, especially in England, a very considerable degree of notice. Dr Maskelyne, the astronomer-royal, adapted it to our system of measures, and Dr Horsley made annotations and comments on it. But, what was of more importance, other accurate observers, incited by De Luc's example, entered the same field of inquiry, provided with instruments of greater delicacy and much better construction. In 1775, Sir George Shuckburgh Evelyn visited the Alps, and combined trigonometrical operations with corresponding observations by barometers and thermometers from the hands of Ramsden; and about this time likewise, General Roy not only measured, with instruments made by that excellent artist, some of the principal mountains in Scotland and Wales, but instituted a series of manometrical experiments. It resulted from all these researches that, for each degree on Fahrenheit's scale, mercury expands the 9700th part, and air the 435th part of their respective bulks. It further appeared that the atmosphere has its temperature almost uniformly diminished at equal ascents; and that the logarithmic difference, reckoning as integers the first four digits, expresses in English fathoms the height of an aerial column as cold as the point of congelation. General Roy proposed likewise another correction depending on the enfeebled gravity, and consequently the augmented altitude of the equiponderant column of atmosphere in the lower latitudes, occasioned by the influence of centrifugal force arising from the earth's rotation. Several years afterwards, Professor Playfair, in a learned paper, printed in the first volume of the *Transactions of the Royal Society of Edinburgh*, examined all the circumstances which can affect barometrical measurements, and discussed each question with the correctness and perspicuity that we might expect from his distinguished abilities. At nearly an equal interval of time, the celebrated Laplace resumed the subject in his *Mecanique Celeste*, and brought all the conditions together in a very complicated formula. Such an appearance of extreme accuracy, however, is perhaps to be regarded merely as a theoretical illusion, unsuited and inapplicable to any real state of practice. Biot has since attempted to arrive at a similar conclusion, by setting out *a priori* from some careful experiments on the relative density of air and mercury, performed by him in conjunction with Arago. He thence infers, that, in the latitude of Paris, and at the point of congelation, air, under a mercurial pressure of 76 *metres*, or 29.922 English inches, is 10,463 times lighter than mercury at the temperature of water at its lowest

contraction. This would give 26,090 feet for the height of a column of homogeneous fluid, whose pressure is equivalent to the elasticity of the atmosphere. The coefficient adapted to common logarithms, and adjusted to the force of attraction at the level of the sea, would therefore be 60,148 feet, or 18,334 *metres*; scarcely differing sensibly from the quantity which Ramond had deduced from a very numerous set of experiments made by him on the Pyrenees. But Biot prefers, as the coefficient, the number 18,393, answering for an elevation of 1200 *metres*, or about 4000 feet above the sea, which is not far from the general level of such observations. The formula is hence, in English feet, $60,346 (1 + .002837 \cos. 2\psi)$ $(1 + \frac{2(T+t)}{1000}) \log. \frac{H}{h}$; where ψ denotes the latitude of the place, T and t the temperatures of the air at the two stations, as indicated by the centesimal thermometer, and H and h the heights of mercurial columns corrected for the effects of heat.

This active writer has likewise given tables for expediting the calculation of barometrical measurements; in which he was anticipated, however, by Oltmans of Berlin, who published, in 1809, large *Hypometrical Tables*, as they are called, accommodated to the complex formula of Laplace. Such tables might, no doubt, prove useful where very frequent computations are wanted, as in the case of the reduction of the numerous observations brought home by Baron Humboldt, for which, indeed, they were first designed. But still they contain a needless profusion of figures, and hold forth a show of extreme accuracy which the nature of the observations themselves can never justify. The mere calculation of barometrical measurements is a secondary object; the great difficulty is to procure good observations, and to combine tolerable accuracy with expedition. For this purpose, a very portable barometer is still wanted;—an instrument light and commodious, exempt from injury or derangement, and yet sensible to minute changes of atmospheric pressure. These properties, indeed, are seldom conjoined, and one advantage must generally be sacrificed to obtain another.

A barometer of the most improved construction is Mountain represented in fig. 19; a portion of the tube is shown in fig. 20; and a section of its cistern in fig. 21. By help of a screw pressing against the bottom of a leather bag, inclosed within a cylindrical ivory box, the mercury is always brought up through a tubular aperture to the same precise level; or till its convex surface appears to touch a very thin line of light, which is admitted through a slip of ivory applied against the side of the chink or separation of this tube from a wider one immediately over it. The lower end of the mercurial column being thus adjusted; the length is easily measured by drawing gradually down a hollow brass tube, divided at intervals by wide slits, covered on one side by thin bits of ivory, till by that softened light a contact is observed with the edge of a slit and the convex top of the column. The fine Vernier which the moveable tube carries gives the altitude of the mercury in thousandth parts of an inch. A thermometer is likewise constantly attached to the instrument, for the purpose of indicating the temperature of the mercury, which, from the heat of the hand in carrying,

Shuckburgh,

and Roy.

Formula of Laplace.

Barometrical Measurements.

or the influence of the solar beams, is commonly warmer than the external air.

This mountain barometer is suspended for observation by jimbols from a tripod, as exhibited in fig. 18; but its several parts can be folded up together into a convenient compass, tolerably well fitted for carriage, as represented in fig. 19. The whole apparatus may not exceed the weight of ten pounds, yet even this, moderate as it might seem, would be felt a serious encumbrance by a traveller who is engaged, day after day, in the labour of climbing mountains. The risk which the instrument incurs, besides, in transporting it perhaps over rough precipices, imposes a perpetual constraint, while, to make correct observations with it, must always require time and patient attention. A lighter and more compact, though less accurate, barometer will generally be preferred by the geological traveller, whose object is rather to extend our acquaintance with the altitudes of mountains, than to aim at a superfluous and often illusory precision. The portable instrument, invented by Sir Henry Englefield, and represented in fig. 14, will, on the whole, answer those views. Its cistern is formed of box-wood, sufficiently tight to hold the mercury, without preventing the access and impression of the external air. When this barometer is inverted, the mercury, therefore, subsides very slowly in the tube, which must be firmly suspended in a vertical position. For greater security, the mercury is now put into a leathern bag introduced within the cistern.

Portable Barometer of Sir H. Englefield;

and of Gay-Lussac.

A very simple and convenient sort of portable barometer was lately invented in France by that celebrated chemical philosopher M. Gay-Lussac. (See fig. 15 and 16.) It consists of rather a wide syphon tube, filled with mercury, and sealed hermetically at the inverted end, having a very fine capillary hole formed about an inch under this, by nicely directing the flame of a blow-pipe against the side of the glass, and drawing a melted spot of it out to a point. The lower portion of the principal branch has its bore contracted to less than the tenth part of an inch, to prevent the mercurial column from dividing in the act of inverting it. The mercury is boiled as usual, and the tube may be concealed in a walking stick, or lodged, like the complete mountain barometer, in a cylinder of brass, with moveable sliders bearing the divisions of a Vernier at both ends. (See fig. 17.) For greater simplicity, however, the larger divisions might be engraved on the tube itself. This kind of barometer is of ready use, and very little exposed to hazard in carriage. It is commonly held in a reclined or inverted position; but, in making an observation, it must be gently turned back, and kept perpendicular till the mercury descends through the contracted bore, and slowly rises again in the opposite short branch; the scale is noticed at both ends of the incurved column, and the difference of those indications gives its correct altitude.

Modified Conical Barometer.

A modification of the conical barometer, which, in travelling, we have ourselves employed with great ease and advantage, should likewise be mentioned. The principal part of it consists of a small stop-cock made of steel, and represented in fig. 13. A glass tube of 31 or 32 inches long, with a bore of the tenth part of an inch hermetically sealed at the top, and filled with quicksilver, is cemented into the one end of the stop-cock; and into the other end is ce-

mented an open and wider tube, 16 inches or more in length, and having its diameter above the eighth part of an inch. This compound tube is lodged in a walking-stick, divided into inches and tenths through its whole extent, or only at the upper part, if uniform tubes be selected. In making an observation, the cock is turned, and the instrument inverted. The upper column then descends partly into the lower tube, till it becomes shortened to the proper altitude.

Barometrical Measurements.

We have already stated the principles on which the calculation of barometrical measurements proceeds. But there still are some points, either assumed or overlooked, which may considerably modify the results. It is presumed, that, at equal successive heights, the temperature of the atmosphere decreases uniformly. This property, however, does not hold strictly, and it may be shown from a comparison of the best observations, that the decrements of heat follow a quicker progression in the higher regions. But we shall soon have another opportunity to examine this subject, and trace out its various consequences.

The humidity of the air also materially affects its elasticity, and the hygrometer should, therefore, be conjoined with the thermometer in correcting barometrical observations. But nothing satisfactory has yet been done with regard to that subject. The ordinary hygrometers, or rather hygrosopes, are mere toys, and their application to science is altogether hypothetical. A most philosophical course has lately been pursued, by multiplying calculations grounded on very loose data, instead of instituting a nice and elaborate train of original experiments.

In the actual state of physical science, it is preposterous, therefore, to affect any high refinement in the formula for computing barometrical measurements. The whole operation may be reduced to a very short and easy process. But the simplicity of the calculation would be still greater, if the centesimal thermometer were generally adopted. It will be sufficiently accurate, till better data are obtained, to assume the expansion of mercury by heat as equal to the 5000th part of its bulk for every centesimal degree, while that of air is twenty times greater, being an expansion for each degree of the 250th part of the bulk of this fluid. 1. Correct the length of the mercurial column at the upper station, adding to it the product of its multiplication into twice the difference between the degrees on the attached thermometers, the decimal point being shifted four places to the left. 2. Subtract the logarithm of this corrected length from that of the lower column, multiply by six, and move the decimal point four places to the right; the result is the approximate elevation expressed in English feet. 3. Correct this approximate elevation, by shifting the decimal point three places back to the right, and multiplying by twice the sum of the degrees on the detached thermometers; this product being now added, will give the true elevation.

Rule for Computing Barometrical Measurements.

If it were judged worth while to make any allowance for the effect of centrifugal force, this will be easily done, before the last multiplication takes place, by adding to twice the degrees on the detached thermometers, the fifth part of the mean temperature corresponding to the latitude. The mean temperature itself is formed by multiplying the square of the cosine of the latitude by 23.

Barometrical Measurements.
Examples.

In illustration of these rules, we shall subjoin some real examples. General Roy, in the month of August 1775, observed the barometer on Caernarvon Quay, at 30,091 inches, the attached centesimal thermometer indicating 15.7, and the detached 15.6; while, on the peak of Snowdon, the barometer fell to 26.409 inches, and the attached and detached thermometers marked respectively 10°,0 and 8°,8. Here twice the difference of the attached thermometers is 11°.4, and twice the sum of the detached thermometer is 48°.8, which becomes 50.8, when augmented by the fifth part of the mean temperature on that parallel. Now, omitting the lower decimals, the first correction is $.00264 \times 11.4 = .030$, to be added to 26.409. Wherefore,

$$\begin{aligned} \text{Log. } 30.091 &= 1.4784366 \\ \text{Log. } 26.439 &= 1.4222450 \\ \text{Difference} &= .0561416 \\ \text{Constant multiplier} &= 60000 \\ \text{Approximate height} &= 3368.496 \end{aligned}$$

And, for the true height, the correction is $3.37 \times 50.8 = 171.2$, which gives 3340 for the final result.

We shall take another example from the observations made by Sir George Shuckburgh Evelyn, at the same period, among the mountains of Savoy. This accurate philosopher found the barometer, placed in a cabin near the base of the Mole, and only 672 feet above the surface of the lake of Geneva, to stand at 28,152 inches, while the attached and detached thermometers indicated 16°.3 and 17°.4; but, another barometer carried to the summit of that lofty insulated mountain, the mercury sunk to 24,176 inches, the attached and detached thermometers marking 14°.4 and 13°.4. Wherefore, twice the difference of the degrees on the attached was 3°.8, and twice the sum of the degrees on the detached thermometer was 61°.6. Consequently, the correction to be applied to the higher column was $.0024 \times 3.8 = .009$, which makes it 4.185. Now,

$$\begin{aligned} \text{Log. } 28,152 &= 1.4495092 \\ \text{Log. } 24,185 &= 1.3835461 \\ \text{Difference} &= .0659631 \\ \text{Constant multiplier} &= 60000 \\ \text{Approximate elevation} &= 3957.786 \end{aligned}$$

To correct this approximate elevation, remove the decimal point three places back, and multiply it by 61°.6, increased by 2°.9, the fifth part of the mean temperature, corresponding to the latitude; but $3.96 \times 64.5 = 255.4$, and $3957.8 + 255.4 = 4213$. Hence the summit of the Mole is 4885 feet above the lake of Geneva, or 6083 feet above the level of the Mediterranean Sea.

The last example we shall give is drawn from the observation which Baron Humboldt made among the Andes, near the summit of Chimborazo, the highest spot ever approached by man. This celebrated traveller found there, that the barometer fell to 14,850 English inches; the attached thermometer in the tent being at 10°, and the detached in open air being 1.6° under zero. But the same barometer, carried down to the shore of the Pacific Ocean, rose exactly to 30 inches, while both the attached and detached thermometers stood at 25°.3. Consequently the cor-

rection to be applied to the upper column is $= .0015 \times 30.6 = .045$. Wherefore,

$$\begin{aligned} \text{Log. } 30,000 &= 1.4771213 \\ \text{Log. } 14.895 &= 1.1730405 \\ \text{Difference} &= .3040808 \\ \text{Constant multiplier} &= 60000 \\ \text{Approximate elevation} &= 18244.848 \end{aligned}$$

Now, the difference of the detached thermometers or 26.9° being doubled and farther increased by 5.8°, the fifth part of the mean temperature at the equator, makes 59°.6; the final correction to be applied is therefore $= 18.24 \times 59°.6 = 1087$, which gives 19,332 feet for the true elevation observed, or 2140 feet below the summit of Chimborazo.

These calculations are performed by the help of Calculation logarithms. It is desirable, however, to approximate at least to barometrical measurements without such aid. A very simple rule for this object has been given by Professor Leslie in his *Elements of Geometry*. Since $\text{Log. } \frac{a}{b} = 2 M \left(\frac{a-b}{a+b} + \frac{1}{3} \left(\frac{a-b}{a+b} \right)^3 + \frac{1}{5} \left(\frac{a-b}{a+b} \right)^5 \&c. \right)$, where M denotes the modulus of the logarithmic system. When a approaches to b , the lower terms may be rejected without

sensible error, or $\text{Log. } \frac{a}{b} = 2 M \left(\frac{a-b}{a+b} \right)$, very nearly.

Wherefore, in reference to our atmosphere, the modulus is expressed by the equiponderant column of homogeneous fluid, or $60,000 \times .4342945 = 26,058$ feet, or only 26,000 in round numbers; whence, as the sum of the mercurial columns is to their difference, so is the constant number 52,000 feet to the approximate height. Let General Roy's observation on Snowdon be resumed as an example: The analogy is $30.091 + 26.439 : 30.091 - 26.439$, or $56.530 : 3.652 :: 52000 : 3,359$, the approximate elevation, differing very little from the logarithmic result.

This mode of calculation may be deemed sufficiently accurate for determining any altitude that exceeds not 5000 feet. But it will extend to greater elevations, if the second term of the series be likewise taken; which is done by striking off three figures, and cubing the half of this number. Thus, resuming the mensuration of Chimborazo; $44.895 : 15.105 :: 52,000 : 17,496$, and $(8.75)^3 = 670$, making together 18,166 for a nearer approximation.

The calculation of barometrical measurements, including the corrections required, is rendered most easy and expeditious by means of a sliding rule made by Mr Cary, optician in London. This small instrument should always go along with mountain barometers, and it will be found a very agreeable companion to every geological traveller.

But portable barometers, in spite of every precaution, are yet so liable to be broken or deranged, that other auxiliary methods are desirable for ascertaining distant elevations. In this view, the variation of the boiling point of water was proposed by Fahrenheit, as far back as the year 1724, the idea having occurred to him, as it had done before to Amontons, while engaged with experiments to perfect his thermometer. Little regard, however, seems to have been paid to the sugges-

Barometrical Measurements.

Calculation without Logarithms.

Barometric Scale.

Barometrical Measurements.

tion, till De Luc and Saussure made a series of observations on the heat of ebullition at different elevations above the surface. About thirty years since, Cavallo attempted to revive the scheme of Fahrenheit, but experienced much difficulty in preventing the irregular starts of the thermometer plunged in boiling water. The best and surest way of examining the heat of ebullition, is to suspend the bulb of the thermometer in the confined steam, as it rises from the water; and this mode, we understand, has very lately been resumed, with great prospect of success, by the Reverend Mr Wollaston.

Temperature of Boiling Water applied to the Measurement of Heights.

The heat at which water boils, or passes into the form of steam, depends on the weight of the superincumbent atmosphere. By diminishing this pressure, the point of ebullition is always lowered. It appears that, while the boiling heat sinks by equal differences, the corresponding atmospheric pressure decreases exactly, or at least extremely nearly, in a geometrical progression; it being found that, every time such pressure is reduced to one half, the temperature of boiling water suffers a regular diminution of about eighteen centesimal degrees. This beautiful relation assimilates with the law which connects the density and elevation of the successive strata of the atmosphere. The interval noticed between the boiling points at two distinct stations must be proportional to their difference of altitude above the level of the sea. We have, therefore, only to determine the coefficient or constant multiplier; which may be discovered either from an experiment under the rarefied receiver of an air-pump, or from an actual observation performed at the bottom and on the top of some lofty mountain. We shall prefer at present the observation made by Saussure on the summit of Mont Blanc. This diligent philosopher found, by means of a very delicate thermometer constructed on purpose, that water which boiled at $101^{\circ}.62$ in the plain below when the barometer stood at 30.534 English inches, boiled at $86^{\circ}.24$ on the top of that mountain, while the barometer had sunk to 17.136. Wherefore the distance between the points of ebullition, or 15.38 centesimal degrees, must correspond to an approximate elevation of 15,050 feet; which gives $978\frac{1}{2}$ feet of ascent for each degree, supposing the mean temperature of the atmospheric column to be that of congelation. But it will be more convenient to assume 1000 for the constant multiplier, which corresponds to the temperature of $5\frac{1}{4}^{\circ}$.

To reduce this very simple result into practice, it would be requisite to have a thermometer with a fine capillary bore, and nicely constructed, the stem six or eight inches long, and bearing ten or a few more degrees from the boiling point; these degrees to be divided into twenty or perhaps fifty equal parts engraved on the tube, which should be rather thick, and terminating in a bulb of about half an inch diameter. This thermometer, being fitted with a brass ring two inches above the bulb, should screw into the narrow neck of a small copper flask, which holds some water, but has a hole perforated near the top for allowing the steam to escape. The water may be made to boil by the application of a lamp. The difference between the indications of the thermometers at the two stations being multiplied by a thousand feet, will give the elevation corresponding to a

temperature of $5\frac{1}{4}^{\circ}$. The correction for the actual mean temperature can easily be applied. If a more correct coefficient be afterwards determined, the same thousand, retained as a multiplier, may easily be adapted to another temperature.

This method of measuring elevations on the surface of the globe is, therefore, capable of great improvement, and might be employed with advantage in a variety of cases where observations with the barometer are not easily obtained. Its application would be most important to physical geography, in ascertaining the capital points for tracing the outline of the profile or vertical section of any country. The common maps, which exhibit mere superficial extension, are quite insufficient to represent the great features of nature, since the climate and productions of any place depend as much on its elevation above the sea as its latitude. Scientific travellers have accordingly turned their attention of late years to the framing of vertical sections. As a specimen, we give in fig. 22, from Humboldt's *Geography of Plants*, a section across the American Continent, one of the best and most interesting that has yet appeared. It consists, in fact, of four combined sections, traversing through an extent of 425 miles. The line begins at Acapulco on the shore of the Pacific Ocean, and runs 195 miles, about a point of the compass towards the East of North, to the city of Mexico; then 80 miles, a point to the South of East, to La Puebla de los Angeles; again it holds a North-East direction of 70 miles, to the Cruz Blanca; and finally bends 80 miles East by South, to Vera Cruz, on the coast of the Atlantic. A scale of altitudes is annexed, which shows the vast elevation of the table-land of Mexico. An attempt is likewise made in this profile to give some idea of the geological structure of the external crust. *Limestone* is represented by straight lines slightly inclined from the horizontal position: *Basalt*, by straight lines slightly reclined from the perpendicular: *Porphyry*, by waved lines somewhat reclined: *Granite*, by confused hatches: *Amygdaloid*, by confused points.

By this mode of distant levelling, a very interesting discovery, in another quarter of our globe, has been recently made by Engelhardt and Parrot, two Prussian travellers. They proceeded, on the 13th July 1814, from the mouth of the Kuban, at the island of Taman, on the Black Sea; and, examining carefully every day the state of the barometer, they advanced with fifty-one observations, the distance of 990 wersts, or 711 English miles, to the mouth of the Terek, on the margin of the Caspian Sea. Similar observations were repeated and multiplied on their return. From a diligent comparison of the whole, it follows that the Caspian is 334 English feet below the level of the Black Sea. That the Caspian really occupies a lower level than the Ocean, had been suspected before, from a comparison of some registers of barometers kept at St Petersburg, and on the borders of that inland sea; but the last observation places the question beyond all doubt. It farther appears, that within 250 wersts, or 189 miles, of the Caspian, the country is already depressed to the level of the Ocean, leaving, therefore, an immense basin, from which the waters are supposed to have retired by a subterranean percolation. (p.)

The Caspian below the level of the Ocean.

BAROMETER.

PLATE XXXII.

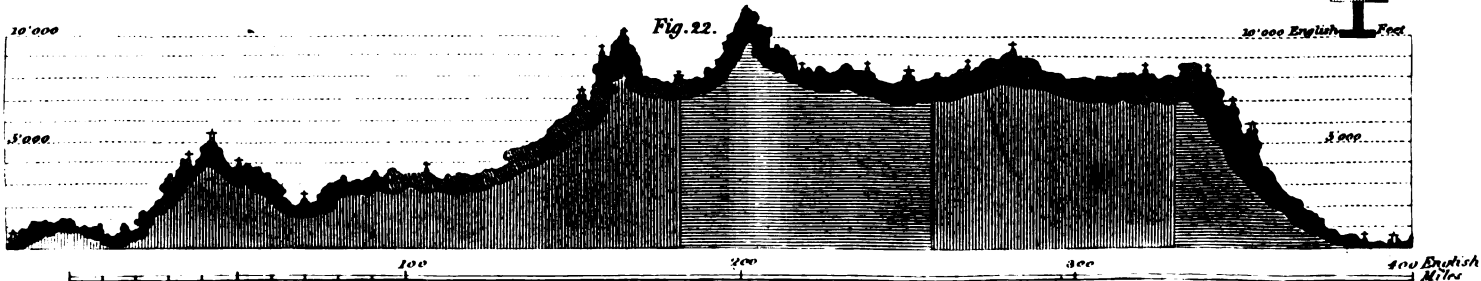
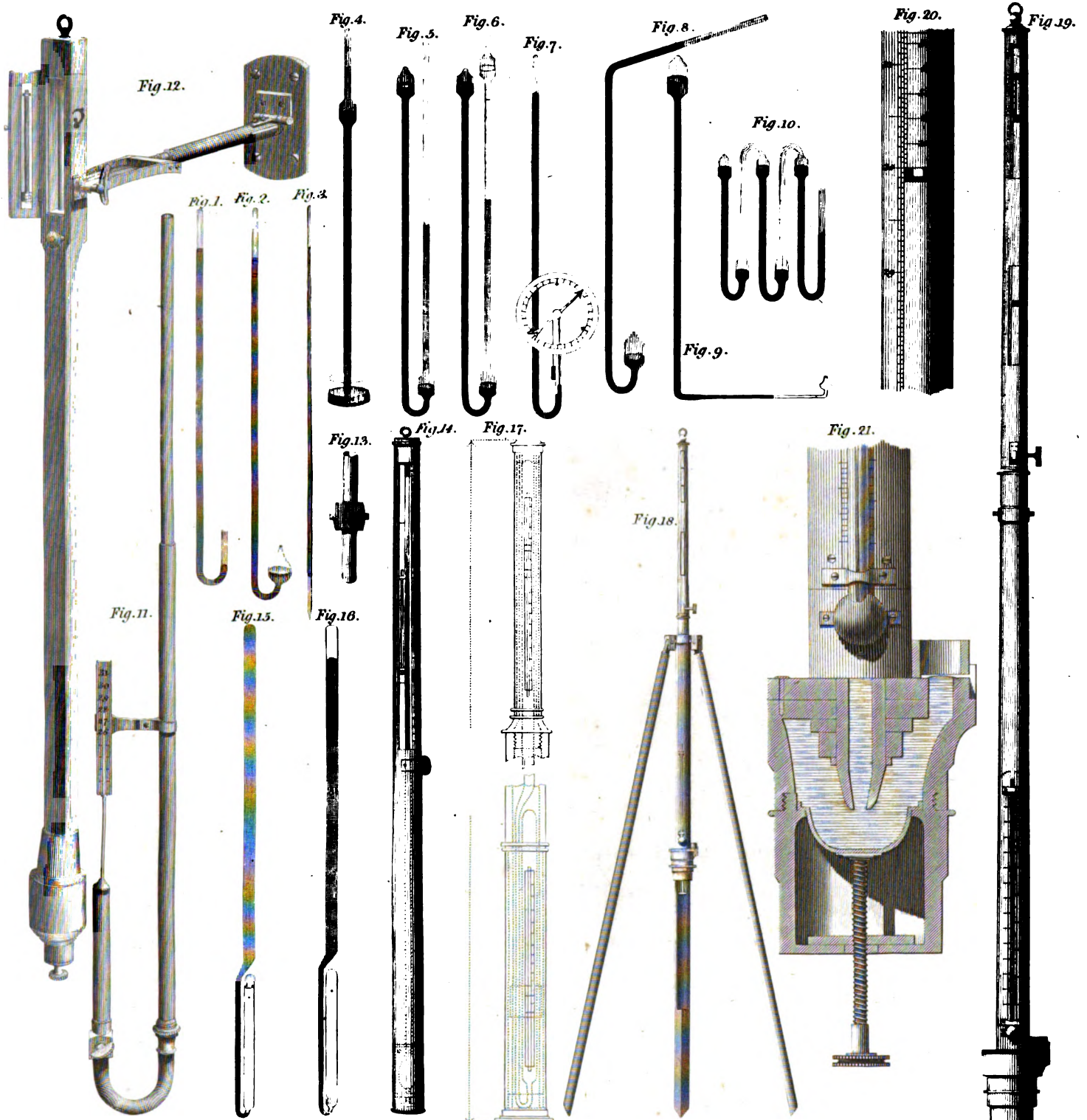

Fig. 22. Drawn by J. Perry The artist

Drawn & Engraved by W. & A. Lizars Edinburgh.

Barracks.
Historical
Notices.

BARRACKS. Till the middle of the year 1792, when there was a prospect of a war with revolutionary France, and the British ministry were apprehensive of disturbances in this country, barracks were neither very numerous, nor were they under the control and management of a separate and peculiar Board. Till that time, they were built under the authority and directions of the Board of Ordnance, by whom they were supplied with bedding and the necessary utensils. Any extra articles that were requisite were supplied by the secretary at war. In 1792, orders were given by the ministry to build cavalry barracks with the utmost despatch, and the deputy-adjutant-general was directed to superintend the building and fitting them up. In January 1793, he was appointed superintendant-general of barracks; and, on the 1st of May that year, the King's warrant was issued for their regulation. Greater powers were given to the superintendant-general in the year 1794; but as these seemed to interfere with the duties and powers of the Board of Ordnance, a new warrant was issued in the year 1795, defining and limiting the respective duties and powers of the Board of Ordnance, and the superintendant-general, or barrack-master-general, as he was now called. In the year 1796, the barrack-office establishment consisted of a barrack-master-general, with two clerks; a deputy-barrack-master-general; an assistant-barrack-master-general, with three clerks; an accountant, with five clerks; an assistant-barrack-master-general for the general inspection of barracks, and six other assistant-barrack-masters-general for the particular inspection of barracks in different districts; five clerks for general business; one assistant-barrack-master-general for the building branch; one checking clerk, and seven other clerks; two architects and surveyors; one assistant-barrack-master-general in North Britain; with two assistants and clerks; one treasurer; and three other assistant-barrack-masters-general for general duties, and visiting barracks. The salaries and extra pay of these officers amounted, in 1796, to L. 9524, 17s. 2d. The establishment was afterwards considerably increased, in proportion as the number of barracks throughout the kingdom increased, and by the creation of some new officers, among whom was a law clerk. In 1806, the salaries amounted to L. 19,329, 4s. 10d.

Official Re-
ports re-
specting
Barracks.

During this year, the commissioners of military inquiry began their duties; and their first reports were on the subject of the barrack establishment: In the arrangement of this establishment, and in the mode in which its duties were performed, particularly with respect to the supplies of coals, &c. to the different barracks, and the contracts for building them, they pointed out many things that were highly objectionable; and concluded their reports by recommending that the offices of barrack-master-general, and deputy-barrack-master-general, should be totally abolished, and that the superintendence of the barrack establishment should be vested in commissioners. This suggestion, and some others relative to the mode of transacting the business of the department, and preventing useless and extravagant expenditure, have been followed; and the barrack establishment is now under the direction of four commissioners, one of

New Ar-
rangements.

VOL. II. PART I.

Barracks.

whom is generally a military man. The mode of writing letters in this public department is deserving of notice and imitation, as securing despatch and accuracy. A sheet of paper being folded in the middle, officers of the department, who address the barrack-office, write their letters on the left side; and, along with the original letter, send a duplicate in the same form, and signed also. On the blank side of the duplicate is written the official answer from the barrack-office which is sent; and, on the original letter, which is preserved in the office, is copied the answer: each party has thus an exact copy of the whole correspondence.

As it frequently happened, that it was absolutely necessary to build barracks on an emergency, when there was no time to summon a jury to value the land before the commencement of the building, and as most persons were averse to have barracks near their dwelling-houses, or even on their property, Government was often obliged to pay an extravagant price for the land which they needed for their erection; in order to remedy this evil, it was provided by the act, usually called the defence act, 43d Geo. III. cap. 55, that Justices of the Peace might put any general officer into the possession of such ground as he might deem fit for the erection of barracks;—the value of it to be settled afterwards by a jury;—provided, however, the necessity for such ground was certified by the Lord-Lieutenant, or two Deputy-Lieutenants of the county.

Clause in
the De-
fence Act
respecting
Barracks.

Barracks throughout the country are more immediately under the management and care of the assistant-barrack-masters-general, and the resident barrack-masters; the former are attached to districts; the latter to particular barracks. The following are the districts in Great Britain:

1. Northern, containing Northumberland, Cumberland, Westmoreland, and Durham. Barrack
Districts.
2. York, containing Yorkshire.
3. Eastern, containing Norfolk, Suffolk, Cambridge, Huntingdonshire, and all Essex, except Tilbury-fort.
4. Southern, containing Kent, Tilbury-fort, and Sussex.
5. South-western, containing Hampshire and Dorsetshire.
6. Isle of Wight.
7. Western, containing Devonshire, Cornwall, and Somerset.
8. Severn, containing Gloucestershire, Worcestershire, Herefordshire, Monmouthshire, and South Wales.
9. North-western, containing Cheshire, Shropshire, Lancashire, North Wales, and the Isle of Man.
10. London.
11. Home, containing Middlesex, Surrey, Hertfordshire, and part of Kent.
12. North-inland, containing Derbyshire, Nottinghamshire, Staffordshire, Warwickshire, Leicestershire, and Rutlandshire.
13. South-inland, containing Bedfordshire, Northamptonshire, Oxfordshire, and Buckinghamshire.
14. Jersey, Guernsey, and Alderney.

Barracks.

SCOTLAND.

Northern, containing Caithness, Sutherland, Ross-shire, Inverness-shire, Nairnshire, Morayshire, and Banffshire.

Western, containing Aberdeenshire, Argyleshire, Ayrshire, Bute, Kincardineshire, Lanarkshire, Renfrewshire, and Wigtonshire.

Centre, containing Angus-shire, Clackmannanshire, Dunbartonshire, Fifeshire, Kinross-shire, Perthshire, and Stirlingshire.

Southern, containing the Lothians, Berwickshire, Peebles-shire, Selkirkshire, Roxburghshire, and Dumfries-shire.

Number of Barracks in Britain and Jersey, &c. On the 14th of July 1805, there were in Great Britain and Jersey, &c.

Established barracks of brick and stone	84
of wood	12
Temporary barracks	75
rented	41
	912

Accommodations and Supplies.

The annual rents at this time amounted to L. 40,231. The whole of these barracks were calculated to accommodate nearly 100,000 foot and 15,000 cavalry. In the cavalry barracks, field-officers have two rooms each; captains one; subalterns, staff, and quarter-masters, one; serjeants of each troop of dragoons, and corporals of each troop of horse, one; eight rank and file one among them; and two rooms are allowed for the officers' mess. In infantry barracks, field-officers are allowed two each; captains one; one is allotted to two subalterns; the staff has one; twelve non-commissioned officers and private men, one among them; the serjeant-major and quarter-master-serjeant, one; and two are allotted for the officers' mess. The barracks are supplied by the barrack-office with beds, bedding, sheets, blankets, towels, house and stable utensils, coals and candles: beer was formerly supplied, but now an allowance is made instead of it. Forage is supplied by the commissariat.

The expence of erecting barracks must of course greatly depend on the price of materials at the time, and, in some measure, on the part of the kingdom where they are erected. In the year 1805, permanent barracks for a battalion of 800 men, in the south of England, cost L. 37,000; and barracks for 1200 infantry and 400 cavalry L. 60,000.

The following statement exhibits the several particulars of the total expence incurred by the nation for barracks, and the barrack-office, in Great Britain, between the 25th of December 1792, and the 10th of November 1804:

Buildings and purchases of land,	L. 3,930,223	5	8
Forage,	846,246	7	10
Beer,	643,030	9	6
Coals, candles, furniture, rents, repairs, supplied by barrack-masters, and salaries,	1,685,487	8	0
Office-establishment,	256,129	10	4
Fees at War-office,	80,346	3	6
Insurance,	1,519	2	2
Additional rents,	36,860	13	5

Expence from 1792 to 1804.

Lodging-money to officers,	-	139,582	16	0	Barracks
Engines,	-	11,866	0	5	Barry.
Bedding, furniture, &c. issued by the Barrack-office, and in store,	1,357,215	7	3		
Miscellaneous,	-	35,498	4	8	
Total,		L. 9,024,005	8	9	

The annual expence, during the last war, varied from L. 350,000 to L. 500,000; in the year 1814, it was L. 309,826. The peace estimate for 1816 is L. 173,500. In Ireland, where barracks are more numerous, the expence, in 1814, was L. 360,515, and the peace estimate for 1816 is L. 213,000.

See first, second, third, and fourth Reports of the Commissioners of Military Inquiry, 1806; and the Finance Reports and Estimates laid before Parliament for the years 1814 and 1816. (c.)

BARRY (JAMES), an eminent painter, was born at Cork, in Ireland, October 11, 1741. His father had been a builder, and at one time of his life, a coasting trader between the two countries of England and Ireland. To this business of a trader was James destined, and he actually made, when a boy, several voyages; but these voyages being forced upon him, he on one occasion ran away from the ship, and on others discovered such an aversion to the life and habits of a sailor, as to induce his father to quit all hopes of him in this line, and to suffer him to pursue his inclinations, which led him to drawing and study. When on board his father's vessel, instead of handling sails and ropes, and climbing the mast, he was generally occupied with a piece of black chalk, sketching the coast, or drawing figures, as his fancy directed him. When his father found that the idea of making a sailor of him must be given up, he permitted him to acquire as much instruction as the schools of Cork afforded; but long retained his aversion to the chalk drawings, with which the floors and walls of the house were covered; the boy being always engaged in some attempt at large figures, and early catching at the means of representing action, attitude, and passion. It was at a very early period of his life that some bookseller in Ireland, undertaking to reprint a set of fables or emblems, young Barry offered to furnish the drawings, and, as it is believed, helped to etch the engravings, such as they were. At the schools in Cork, which he was sent to, he was distinguished by his parts and industry above his school-fellows; his habits differed from those of ordinary boys, as he seldom mixed in their games or amusements, but at those times stole off to his own room, where he worked at his pencil, or was studying some book that he had borrowed or bought. He would spend whole nights in this manner at his studies, to the alarm of his mother, who dreaded his injuring his health or setting fire to the house, and who often kept up his sister or the servant to watch him. His allowance of money he spent in buying books or candles to read by; he sometimes locked himself up in his room for days, and seldom slept upon his bed, or else made it so hard as to take away the temptation or luxury of lying long in it. Perhaps the unsocial and ascetic turn of his temper,

Barry. which thus early manifested itself, might be remarked as the source both of the misfortunes of his life, and of the defects of his genius. Common humanity, a sense of pleasure, and a sympathy with the feelings of those around us, is not more necessary to success in life, than it probably is to success in the fine arts. Few things can be more fatal to the artist than this sort of indifference to the common pleasures and pursuits of life. If affected, it is bad; if real and constitutional, it is even worse. It stuck to poor Barry to the last. It is not to be understood that, at this period of his life, he led the life of an absolute recluse, for he could and did occasionally join in any feats going on in the neighbourhood, and was not behind other boys in such pastimes and mischief as boys are usually fond of. An adventure which happened to him about this time, and which left a strong impression on his mind, is worth mentioning here. In one of his rambles in the neighbourhood, he entered, one winter's evening, an old, and, as he thought, an uninhabited house, situate in a narrow bye-lane in the city of Cork. The house was without doors or windows; but curiosity impelled him to enter, and, after mounting a rotten staircase, which conducted to empty rooms on different floors, he arrived at the garret, where he could just discern, by the glimmering light of a few embers, two old and emaciated figures, broken by age, disease, and want, sitting beside each other, in the act, as far as their palsied efforts would permit, of tearing each other's faces; not a word being uttered by either, but with the most horrible grimaces that malice could invent. They took no notice of his entrance, but went on with their deeds of mutual hate, which made such an impression on the boy that he ran down stairs, making his own reflections, which he afterwards found verified through life, that man and all animals are malicious and cruel in proportion as they are impotent; and that age and poverty, two of the worst evils in human life, almost always add to the calamities inherent in them by arts of their own creating. In general, his great desire to improve his mind led him to seek the society of educated men; who were not averse to receive him, seeing his active and inquisitive disposition, and his seriousness of manner, couched under a garb the plainest and coarsest; for he adopted this kind of attire from his childhood, not from affectation, but from an indifference to all dress. Having a retentive memory, he profited by his own reading, and by the conversation of others, who directed him also in the choice of books. As his finances were too low to make many purchases, he borrowed books from his friends, and was in the practice of making large extracts from such as he particularly liked, and sometimes even of copying out the whole book, of which several specimens were found among his papers, written in a stiff school-boy's hand. As his industry was excessive, his advances in the acquisition of knowledge were rapid, and he was regarded as a prodigy by his school-fellows. His mother being a zealous Catholic, the son could not avoid mixing at times in the company of priests resident at Cork, who pointed out to him books of polemical divinity, of which he became a great reader, and for which he retained a strong bias

during his lifetime. He was said at one time to have been destined for the priesthood, but for this report there is no authority. He, however, always continued a Catholic, and in the decline of life manifested rather a bigoted attachment to the religion of his early choice. For a short interval he had a little wavering in his belief of revealed religion in general; but a conversation with Mr Edmund Burke put an end to this levity. A book which Mr Burke lent him, and which settled his mind on this subject, was Bishop Butler's *Analogy*; and as a suitable reward, he has placed this Prelate in the group of divines, in his picture of Elysium.

About the age of seventeen he first attempted oil paintings; and between that and the age of twenty-two, when he first went to Dublin, he produced several large ones, which decorated his father's house, and represented subjects not often handled by young men; such as *Æneas* escaping with his family from the flames of Troy; *Susanna* and the Elders; *Daniel* in the Lion's Den, &c. At this period, he also produced the picture which first drew him into public notice, launched him on an ampler theatre than his native town of Cork afforded, and, above all, gained him the acquaintance and patronage of Mr Burke. This picture was founded on an old tradition of the landing of St Patrick on the sea-coast of Cashel, and of the conversion and baptism of the king of that district by the patron saint of Ireland. The priest, in the act of baptizing his new convert, inadvertently strikes the spear of the crozier in the foot of the monarch. The holy father, absorbed in the duties of his office, does not perceive what he has done, and the king, without interrupting the ceremony, bears the pain with immoveable fortitude. This incident, together with the gestures and expressions of the attendants, certainly formed a good subject for an historical picture; and Mr Barry's manner of treating it was such as to ensure him the applause and admiration of the connoisseurs of the metropolis of the sister kingdom, where it was exhibited in 1762 or 1763. Mr Barry took this picture with him to Dublin; and afterwards going to the exhibition room, being delighted with the encomiums it received from the spectators, he could not refrain from making himself known as the painter. His pretensions were treated with great contempt by the company, and Barry burst into tears of anger and vexation. But the incredulity of his hearers was a compliment paid to the real or supposed excellence of his painting. It appears that a Dr Sleigh, a physician of Cork, and a sensible and amiable man, was first instrumental in introducing young Barry to the notice of Mr Burke. During their early acquaintance, having fallen into a dispute on the subject of taste, Barry quoted a passage in support of his opinion from the *Essay on the Sublime and Beautiful*, which had been just then published anonymously, and which Barry, in his youthful admiration of it, had, it seems, transcribed entire. Burke affected to treat this work as a theoretical romance, of no authority whatever, which threw Barry into such a rage in its defence, that Mr Burke thought it necessary to appease him by owning himself to be the author. The scene ended in Barry's

Barry. running to embrace him, and showing him the copy of the work, which he had been at the pains to transcribe. He passed his time in Dublin in reading, drawing, and society. While he resided here, an anecdote is preserved of him, which marks the character of the man. He had been enticed by his companions several times to carousings at a tavern, and one night, as he wandered home by himself, a thought struck him of the frivolity and viciousness of thus mis-spending his time: the fault, he imagined, lay in his money, and, therefore, without more ado, in order to avoid the morrow's temptation, he threw the whole of his wealth, which perhaps amounted to no great sum, into the Liffey, and locked himself up at his favourite pursuits. After a residence of seven or eight months in Dublin, an opportunity offered of accompanying some part of Mr Burke's family to London, which he eagerly embraced. This took place sometime in the year 1764, when he was twenty-three years of age, and with one of those advantages which do not always fall to the lot of young artists on their arrival in the British capital, that of being recommended to the acquaintance of the most eminent men in the profession by the persuasive eloquence of a man who, to genius in himself, added the rare and noble quality of encouraging it in others; this was Mr Burke, who lost no time, not merely in making Barry known, but in procuring for him the first of all objects to an inexperienced and destitute young artist, employment. This employment was chiefly that of copying in oil drawings by Mr Stewart, better known by the name of Athenian Stewart; and whether it suited the ambition of Barry or not, to be at this kind of labour, yet there can be no doubt that he profited by his connection with such a man as Stewart, and had full leisure to cast his eye about, and to improve by the general aspect of art and artists that occupied the period.

Mr Burke and his other friends thinking it important that he should be introduced to a wider and nobler school of art than this country afforded, now came forward with the means necessary to accomplish this object; and in the latter end of 1765 Mr Barry proceeded to the Continent, where he remained till the beginning of 1771, studying his art with an enthusiasm which seemed to augur the highest success, and making observations on the different *chef d'œuvres* of Italy with equal independence of judgment and nicety of discrimination. He was supported during this period by the friendly liberality of the Burke family (Edmund, William, and Richard), who allowed him forty pounds a-year for his necessary expenditure, besides occasional remittances for particular purposes. He proceeded first to Paris, then to Rome, where he remained upwards of three years, from thence to Florence and Bologna, and home through Venice. His letters to the Burkes, giving an account of Michael Angelo, Raphael, Titian, and Leonardo da Vinci, show a complete insight into the characteristic merits of their works, and would make us wonder (if the case were at all singular) how he could enter with such force, delicacy, and feeling, into excellencies of which he never transplanted an atom into his own works. He saw, felt, and wrote; his impressions were profound and refined, but the

Barry. expression of them must be instantaneous, such as gave the results of them with a stroke of the pen, as they were received by a glance of the eye, and he could not wait for the slow process of the pencil for embodying his conceptions in the necessary details of his own art. It was his desire to make the ideas and language of painting coinstantaneous,—to express abstract results by abstract mechanical means (a thing impossible),—to stamp the idea in his mind at once upon the canvass, without knowledge of its parts, without labour, without patience, without a moment's time or thought intervening between what he wished to do and its being done, that was perhaps the principal obstacle to his ever attaining a degree of excellence in his profession at all proportioned either to his ambition or his genius. It is probable, that, as his hand had not the patience to give the details of objects, his eye, from the same habit of mind, had not the power to analyze them. It is possible, however, to see the results without the same laborious process that is necessary to convey them; for the eye sees faster than the hand can move.

We suspect Mr Barry did not succeed very well in copying the pictures he so well describes; because he appears to have copied but few, only one of Raphael, as far as we can find, and three from Titian, whom he justly considered as the model of colouring, and as more perfect in that department of the art than either Raphael or Michael Angelo were in theirs, expression and form, the highest excellence in which he conceives to have been possessed only by the ancients. In copying from the antique, however, he manifested the same aversion to labour, or to that kind of labour which, by showing us our defects, compels us to make exertions to remedy them. He made all his drawings from the antique, by means of a *delineator*, that is, a mechanical instrument, to save the trouble of acquiring a knowledge both of form and proportion. In this manner, equally gratifying to his indolence and his self-love, he is stated to have made numberless sketches of the antique statues, of all sizes, and in all directions, carefully noting down on his sketch-paper their several measurements and proportions.

The consequences are before us in his pictures; namely, that all those of his figures which he took from these memorandums are deficient in everything but form, and that all the others are equally deficient in form and everything else. If he did not employ his pencil properly, or enough, in copying from the models he saw, he employed his thoughts and his pen about them with indefatigable zeal and spirit. He talked well about them; he wrote well about them; he made researches into all the collateral branches of art and knowledge, sculpture, architecture, cameos, seals, and intaglios. There is a long letter of his, addressed to Mr Burke, on the origin of the Gothic style of architecture, written, as it should seem, to convince his friend and patron of his industry in neglecting his proper business. Soon after his arrival at Rome, he became embroiled with the whole tribe of connoisseurs, painters, and patrons there, whether native or foreign, on subjects of *virtù*; and he continued in this state of hostility with those

Barry. around him while he staid there, and, indeed, to the end of his life. One might be tempted to suppose, that Barry chiefly studied his art as a subject to employ his dialectics upon. On this unfortunate disposition of his to wrangling and controversy, as it was likely to affect his progress in his art and his progress in life, he received some most judicious advice from Sir Joshua Reynolds and Mr Burke, his answers to which show an admirable self-ignorance. On his irritable denunciations of the practices and tricks of the Italian picture-dealers, Mr Burke makes a reflection well deserving of attention. "In particular, you may be assured that the traffic in antiquity, and all the enthusiasm, folly, and fraud, which may be in it, *never did, nor never can hurt the merit of living artists.* Quite the contrary, in my opinion; for I have ever observed, that, whatever it be that turns the minds of men to anything relative to the arts, even the most remotely so, brings artists more and more into credit and repute; and though, now and then, the mere broker and dealer in such things runs away with a great deal of profit, yet, in the end, ingenious men will find themselves gainers by the dispositions which are nourished and diffused in the world by such pursuits." Mr Barry painted two pictures while abroad, his Adam and Eve and his Philoctetes. The first of these he sent home as a specimen of his progress in the art. It does not appear to have given much satisfaction. His Philoctetes he brought home with him. It is a most wretched, coarse, unclassical performance, the directly opposite to all that he thought it to be. During his stay at Rome, he made an excursion to Naples, and was highly delighted with the collections of art there. All the time he was abroad, Mr Burke and his brothers not only were punctual in their remittances to him, but kept up a most friendly and cordial correspondence. On one occasion, owing to the delay of a letter, a bill which Barry had presented to a banker was dishonoured. This detained Barry for some time at the place where he was in very awkward circumstances, and he had thoughts of getting rid of his chagrin and of his prospects in life at once, by running away and turning friar. For some time previous to his return to England, Mr Hamilton (afterwards Sir William) appears to have been almost the only person with whom he kept up any intimacy. It was on his return home through Milan that he witnessed, and has recorded with due reprobation, the destruction of Leonardo's Last Supper, which two bungling artists were employed to paint over by order of one Count de Firmian, the secretary of state.

In the spring of 1771, Mr Barry arrived in England, after an absence of five years. He soon after produced his picture of Venus, which has been compared to the Galatea of Raphael, the Venus of Titian, and the Venus of Medicis, without reason. Mr Barry flattered himself that he had surpassed the famous statue of that name, by avoiding the appearance of *maternity* in it. There is an engraving of it by Mr Valentine Green. In 1773, he exhibited his Jupiter and Juno on Mount Ida, which was much praised by some critics of that day. His Death of General Wolfe was considered as a falling off from

his great style of art, which consisted in painting Greek subjects, and it accordingly is said to "have obtained no praise." His fondness for Greek costume was assigned by his admirers as the cause of his reluctance to paint portraits; as if the coat was of more importance than the face. His fastidiousness, in this respect, and his frequent excuses, or blunt refusals, to go on with a portrait of Mr Burke, which he had begun, caused a misunderstanding with that gentleman, which does not appear to have been ever entirely made up. The difference between them is said to have been widened by Burke's growing intimacy with Sir Joshua, and by Barry's feeling some little jealousy of the fame and fortune of his rival in an *humbler walk of the art.* He, about the same time, painted a pair of classical subjects, Mercury inventing the lyre, and Narcissus looking at himself in the water, the last suggested to him by Mr Burke. He also painted an historical picture of Chiron and Achilles, and another of the story of Stratonice, for which last the Duke of Richmond gave him a hundred guineas. In 1773, there was a plan in contemplation for our artists to decorate the inside of St Paul's with historical and sacred subjects; but this plan fell to the ground, from its not meeting with the concurrence of the Bishop of London and the Archbishop of Canterbury, to the no small mortification of Barry, who had fixed upon the subject he was to paint,—the rejection of Christ by the Jews when Pilate proposes his release. In 1775, he published *An Inquiry into the real and imaginary Obstructions to the Acquisition of the Arts in England*, vindicating the capacity of the English for the fine arts, and tracing their slow progress hitherto to the Reformation; to political and civil dissensions; and, lastly, to the general turn of the public mind to mechanics, manufactures, and commerce. In the year 1774, shortly after the failure of the scheme for decorating St Paul's, a proposal was made, through Mr Valentine Green, to the same artists, Reynolds, West, Cipriani, Barry, &c. for ornamenting the great room of the Society for the *Encouragement of Arts, Manufactures, and Commerce*, in the Adelphi, with historical and allegorical paintings. This proposal was, at the time, rejected by the artists themselves; but, in 1777, Mr Barry made an offer to paint the whole himself, on condition of being allowed the choice of his subjects, and being paid the expence of canvass, paints, and models, by the Society. This offer was accepted, and he finished the series of pictures at the end of seven years, instead of two, which he had proposed to himself, but with entire satisfaction to the members of the Society, for whom it was intended, and who conducted themselves to him with liberality throughout. They granted him two exhibitions, and at different periods voted him 50 guineas, their gold medal, and again 200 guineas, and a seat among them. Dr Johnson remarked, when he saw the pictures, that, "whatever the hand had done, the head had done its part." There was an excellent anonymous criticism, supposed to be by Mr Burke, published on them, in answer to some remarks put forth by Barry, in his descriptive catalogue, on the *ideal* style of art, and the necessity of size to gran-

Barry.

Barry.

deur. His notions on both these subjects are very ably controverted, and, indeed, they are the rock on which Barry's genius split. It would be curious if Mr Burke were the author of these strictures; for it is not improbable that Barry was led into the last error, here deprecated, by that author's *Essay on the Sublime and Beautiful*. The series consists of six pictures, showing the progress of human culture. The first represents Orpheus taming the savages by his lyre. The figure of Orpheus himself is more like a drunken bacchanal than an inspired poet or lawgiver. The only part of this picture which is valuable is the background, in one part of which a lion is seen ready to dart upon a family group milking near a cave, and, in another, a tyger is pursuing a horse. There is certainly a scope of thought and picturesque invention, in thus showing indirectly the protection which civilization extends, as it were, over both man and animals. The second picture is a Grecian harvest, which has nothing Grecian in it. But we cannot apply this censure to the third picture of the Olympic games, some of the figures in which, and the principal group, are exceedingly graceful, classical, and finely conceived. This picture is the only proof Mr Barry has left upon canvass that he was not utterly insensible to the beauties of the art. The figure of the young man on horseback really reminds the spectator of some of the Elgin marbles; and the outlines of the two youthful victors at the games, supporting their father on their shoulders, are excellent. The colouring is, however, as bald and wretched in this picture as the rest, and there is a great want of expression. The fourth picture is the triumph of commerce, with Dr Burney swimming in the Thames, with his hair powdered, among naked sea-nymphs. The fifth, the Society of Arts, distributing their annual prizes. And the sixth represents Elysium. This last picture is a collection of caricatured portraits of celebrated individuals of all ages and nations, strangely jumbled together, with a huge allegorical figure of Retribution driving Heresy, Vice, and Atheism, into the infernal regions. The moral design of all these pictures is much better explained in the catalogue than on the canvass; and the artist has added none of the graces of the pencil to it in any of them, with the exception above made. Mr Barry appears, however, to have rested his pretensions to fame as an artist on this work, for he did little afterwards but paltry engravings from himself, and the enormous and totally worthless picture of Pandora in the assembly of the gods. His self-denial, frugality, and fortitude, in the prosecution of his work at the Adelphi, cannot be too much applauded. He has been heard to say, that at the time of his undertaking it, he had only 16s. in his pocket; and that he had often been obliged, after painting all day, to sit up at night to sketch or engrave some design for the printsellers, which was to supply him with his next day's subsistence. In this manner he did his prints of Job, dedicated to Mr Burke, of the Birth of Venus, Polemon, Head of Chatham, King Lear, from the picture painted for the Shakespear gallery, &c. His prints are caricatures even of his pictures: they seem engraved on rotten wood.

Barry.

Soon after Mr Barry's return from the Continent, he was chosen a member of the Royal Academy; and in 1782, was appointed professor of painting, in the room of Mr Penny, with a salary of L. 30 a-year. The lectures which he delivered from the chair were full of strong sense, and strong advice, both to the students and academicians. Among other things, he insisted much on the necessity of purchasing a collection of pictures by the best masters as models for the students, and proposed several of those in the Orleans collection. This recommendation was not relished by the academicians, who, perhaps, thought their own pictures the best models for their several pupils. Bickerings, jealousies, and quarrels arose, and at length reached such a height, that, in 1799, Mr Barry was expelled from the academy, soon after the appearance of his *Letter to the Dilettanti Society*; a very amusing, but eccentric publication, full of the highest enthusiasm for his art, and the lowest contempt for the living professors of it. In 1800, he undertook a design or drawing to celebrate the union of the two kingdoms of Great Britain and Ireland. The profits of the two exhibitions of the Adelphi pictures are said to have amounted to above L. 500. Lord Romney presented him with 100 guineas for his portrait, which had been copied into one of the pictures, and he had 20 guineas for a head of Mr Hooper. He probably received other sums for portraits introduced into the work. By extreme frugality he contrived, not only to live, but to save money. His house was twice robbed of sums which he kept by him; one of the times (in 1794) of upwards of L. 100; a loss which was made up by the munificence of Lord Radnor, and by that of his friends, the Hollis's. After the loss of his salary, a subscription was set on foot by the Earl of Buchan to relieve him from his difficulties, and to settle him in a larger house to finish his picture of Pandora. The subscription amounted to L. 1000, with which an annuity was bought; but of this he was prevented from enjoying the benefit; for, on the 6th of February 1806, he was seized with a pleuritic fever, and as he neglected medical assistance at first, it was afterwards of no use. After lingering on for a fortnight in considerable pain, but without losing his fortitude of mind, he died on the 22d of the same month. On the 13th of March, the body was taken to the great room of the Society of Arts, and was thence attended, the following day, by a numerous and respectable train of his friends to the cathedral of St Paul's, where it was deposited.

Mr Barry, as an artist, a writer, and a man, was distinguished by great inequality of powers and extreme contradictions in character. He was gross and refined at the same time; violent and urbane; sociable and sullen; inflammable and inert; ardent and phlegmatic; relapsing from enthusiasm into indolence; irritable, headstrong, impatient of restraint; captious in his intercourse with his friends, wavering and desultory in his profession. In his personal habits he was careless of appearances or decency, penurious, slovenly, and squalid. He regarded nothing but his immediate impulses, confirmed into incorrigible ha-

Barry
Barthez

bits. His pencil was under no control. His eye and his hand seemed to receive a first rude impulse, to which it gave itself up, and paid no regard to any thing else. The strength of the original impetus only drove him farther from his object. His genius constantly flew off in tangents, and came in contact with nature only at salient points. There are two drawings of his from statues of a lion and a lioness at Rome; the nose of the lioness is two strait lines; the ears of the lion two curves, which might be mistaken for horns; as if, after it had taken its first direction, he lost the use of his hand, and his tools worked mechanically and monotonously without his will. His enthusiasm and vigour were exhausted in the conception; the execution was crude and abortive. His writings are a greater acquisition to the art than his paintings. The powers of conversation were what he most excelled in; and the influence which he exercised in this way over all companies where he came, in spite of the coarseness of his dress, and the frequent rudeness of his manner, was great. Take him for all in all, he was a man of whose memory it is impossible to think without admiration as well as regret.

(z.)

BARTHEZ (PAUL JOSEPH), one of the most celebrated physicians of the University of Montpellier, equally remarkable for the variety and extent of his erudition, as for the vigour of mind displayed in his abstruse speculations. He was born on the 11th of December 1734, at Montpellier, and received his early education at Narbonne, where his family resided, and afterwards at Toulouse. He soon gave decisive indications of those talents with which nature had endowed him, and which destined him to occupy a distinguished station among the learned men of the age. Ardent in his pursuit of knowledge, and uniting great quickness of apprehension, with a tenacious memory, his progress in every study which he attempted was more than ordinarily rapid; he had a remarkable facility in acquiring languages, and at an early age, had made himself master of the ancient and of several modern ones. He seems to have been for some time uncertain what profession he should follow; but having at length, at the instigation of his father, commenced the study of medicine at Montpellier, in 1750, he pursued it with eagerness, and his success was proportionate to his exertions; for, in 1753, when he had only attained his 19th year, he received his doctor's degree. He afterwards occasionally visited Paris, where he continued to pursue his studies with indefatigable industry; and attracting the notice, not only of those who were following the same objects, but of those who could better appreciate the full extent of his attainments, was admitted to the society, and acquired the friendship of the most distinguished literati of that period. In 1756, he obtained the appointment of physician to the military hospital in Normandy, attached to the army of observation commanded by Marshal Destrées. The zeal and assiduity with which he discharged the duties of his new office were most exemplary. He seemed determined to profit to the utmost by the extensive field of observation which was thus opened to him, and in which he could put to the test of experience the knowledge which he had

derived from other sources, and train himself in those habits of nice discrimination of symptoms, and of prompt decision in practice, without which learning is of little avail in the actual exercise of the art. He spent his whole time at the hospital, and often passed the night by the bed-side of his patients. Though naturally of a good constitution, his strength was not commensurate with the ardour of his mind, and the tasks in which he engaged were frequently undertaken without duly appreciating the physical powers necessary for accomplishing them. His health suffered much from the intensity of his application, and he was often very near falling a sacrifice to fevers and other disorders, which he caught from the patients in the hospital, whom he was attending too closely; and he thence became liable ever after to attacks of dysentery and bilious fever.

Many of the observations and inquiries, which he made during this period, were published in the *Memoirs of the Academy of Sciences*; and two of his first productions were crowned by the Academy of Inscriptions. In 1757, his services were required in the medical staff of the army of Westphalia, where he had the rank of consulting physician. On his return to Paris, he contributed several articles to the *Journal des Savants*, and to the *Encyclopédie*; and was, indeed, considered for a time as one of the editors of the former of those works. In 1761, he became candidate for a medical professorship at Montpellier, which he fortunately succeeded in obtaining, and in which his abilities as a teacher soon shone forth with unrivalled lustre. His success was the more honourable, inasmuch as his colleagues, Lamoignon, Leroy, and Venel, were men of distinguished reputation, and had raised the school to a high pitch of celebrity. But the singular perspicuity, and precision of method, and the peculiar grace and facility of elocution, with which Barthez conveyed to his hearers the ample stores of knowledge of which he was in possession, soon attracted a crowd of auditors, who spread his fame in all directions. He taught in succession all the branches of the medical art; and pronounced, at the opening of the session in 1772, a Latin oration on the *Vital Principle* in man; which was published in the following year. About the same time appeared his work, entitled, *Nova Doctrina de Functionibus Corporis Humani*. These two works contain a sketch of his peculiar doctrines in physiology; doctrines which he more fully explained in a subsequent book, under the title of *Nouveaux Elémens de la Science de l'Homme*, 8vo, Montpellier, 1778; and of which we shall presently give an account.

In 1774, he was created joint chancellor of the university, with the certainty of succeeding singly to the office on the death of his colleague, which happened in 1786. He afterwards took the degree of doctor in civil law, and was appointed counsellor to the Supreme Court of Aids at Montpellier. In 1780, he was induced to fix his residence in Paris, having been nominated consulting physician to the King, with a brevet of counsellor of state, and a pension of a hundred louis. Honours now crowded upon him; he was admitted free associate of the Academies of Sciences and of Inscriptions, and appoint-

Barthez.

Barthes. ed first physician to the Duke of Orleans, in the room of Tronchin. His reputation increased in proportion as his merits could be displayed on a wider theatre. He practised as physician at Paris for nearly ten years, and received the most flattering testimonials of public approbation.

This brilliant career was suddenly interrupted by the great political revolution which broke out at this period, and by which the interests of every individual in France, however tranquil his pursuits, or obscure his station, were more or less immediately affected.

It was the occasion of Barthes quitting Paris, and seeking in his native province that tranquillity and repose, which the stormy aspect of the times forbade him to hope for in a more conspicuous station, holding, as he did, opinions so much at variance with the new order of things. Though he had lost the greater part of his fortune, acquired by so much labour, and was deprived of the honours to which he possessed so just a claim, he determined, upon his retiring to Carcassone, that he would practise his profession gratuitously, and devote all his leisure hours to the speculative studies connected with it, which had been the ruling passion of his life. It was in this retreat that he gave to the world his *Nouvelle Mécanique des Mouvements de l'Homme et des Animaux*, which appeared in 1798, in quarto; and it was at this period, also, that he composed his work on *Gout*, a disease to which his attention had been naturally directed, in consequence of his having frequently suffered under its attacks.

An occasion soon occurred which demanded his services, and he once more emerged from his retirement, and repaired to the head-quarters of the army of the Eastern Pyrenees, where a contagious fever, originating from the accumulation of sick in the military hospitals of Perpignan, was committing great ravages. The progress of this contagion was effectually arrested by the adoption of the measures which he advised.

On the re-establishment of the College of Medicine at Montpellier, Barthes was naturally looked up to as the person best calculated to revive its former fame. But age and infirmity operated to dissuade him from resuming the laborious office of a teacher; and he was accordingly nominated honorary professor. It was in this capacity that he pronounced, in 1801, his *Discours sur le génie d'Hippocrate*, on the solemn inauguration of the bust of the father of medicine in that school. In the following year, he received several marks of favour from the new government under Bonaparte; he was nominated titular physician to the government, and afterwards consulting physician to the Emperor, and member of the Legion of Honour.

His *Traité des Maladies Goutteuses*, in two volumes, octavo, appeared in 1802; and he afterwards occupied himself in preparing for the press a new edition of his *Elémens de la Science de l'Homme*, of which he but just lived to see the publication. His health had been declining for some years before his death; he was subject to attacks of melancholy, which obliged him to desist from pursuits that required intense application, and at length induced him to

change the scene altogether, and seek relief amidst the society and amusements of the capital, where he was generally honoured and esteemed. Soon after his removal to Paris, symptoms of the stone manifested themselves, and increased so much in severity, that he was advised to submit to the operation of lithotomy, as affording the only means of arresting a lingering and painful death. But he constantly refused to undergo the pain and risk to which it would have necessarily exposed him, till, after long protracted suffering, during which he had in vain exhausted all the resources of medicine, he was suddenly relieved by a symptomatic spitting of blood; this hæmorrhage, however, was pregnant with new dangers, and, by its continual recurrence, was the immediate occasion of his death, on the 15th of October 1806, in the 72d year of his age. As we have already stated, he had published in the same year a second edition of his *Nouveaux Elémens de la Science de l'Homme*. He bequeathed his books and manuscripts to M. Lordat, who, in consequence, published two volumes of *Consultations de Médecine*, 8vo, Paris, 1810, to which he prefixed a preface of his own. Previous to the appearance of this work, however, a collection of consultations of Barthes, and of some other physicians of Paris, was given to the world by Saint-Ursin; but it appears to have been unauthorized by those to whom he had confided his papers, and contains but few of the consultations which were afterwards published by M. Lordat. Another posthumous work of Barthes, the *Traité du Beau*, preceded by some account of his life, was edited in 1807 by his brother, M. Barthes de Marmorières, who is known as the author of agricultural essays, and projects for improving the maritime coast of Languedoc, together with some translations from the oriental languages; and who has been mistaken, in a recent biographical work, for the subject of the present article.

Barthes has enjoyed a much higher reputation on the Continent than in this country, where, indeed, his writings are but little known. The work which has chiefly contributed to establish his fame, and which contains the developement of his peculiar opinions on physiology, is the *Nouveaux Elémens de la Science de l'Homme*. It is not written, however, with the simplicity and clearness which might have been expected from one who had been in the constant habit of instructing others, and whose lectures were generally admired as possessing those qualities in an eminent degree. He appears to have been early impressed with the futility of all the theories that had hitherto advanced in explanation of the phenomena presented by living beings, and to have been incited to the bold attempt of raising a new system upon more rational and solid foundations. In the preliminary discourse to the work we have alluded to, he lays down, with great correctness, the fundamental principles of the method of philosophizing in the natural sciences. The common object of these sciences he states to be the research into the causes of natural phenomena, in as far as they can be learned by experience; and shows that we have no direct knowledge of these causes, except as manifested by such of their effects as we perceive. In the infancy of philosophy, numerous causes are assigned to these

Barthez. apparently diversified effects; during its advancement, and in proportion as the similarity of effects, which had been referred to different causes, is established, the number of these assigned causes becomes more and more circumscribed. Although the real nature of the agents producing those general facts, to which we ultimately arrive by following this method of induction, be absolutely unknown, yet, in reasoning concerning them, we find it convenient to express them by a name, as if they were really known to us; in the same way as in prosecuting an algebraical calculus, we must employ characters to express the unknown, as well as the given quantities. But the distinction should ever be kept in view; and we should err greatly were we to imagine that we could derive any ultimate advantage by the substitution of other symbols, which differed from them only in appearance, or which involved the admission of some hypothetical principle.

Such are the rules by which he professes to be guided in his own investigations; and such the tests by which he examines and passes judgment upon the doctrines of the different sects of Animists, Mechanists, and Chemists, which had successively prevailed before him in the schools of medicine, and also upon the more recent doctrine of the Solidists, which was then becoming fashionable. In the review which he gives of the opinions of the several leaders of these sects, he displays an accurate acquaintance with the wide circle of medical literature. But, in the prosecution of his plan, he shows, what the example of others has so often proved, that it is easier to overthrow than to build a system; and he evidently violates the strict principles of induction, and of cautious limitation to the province of philosophical inquiry, which he had prescribed, when he engages in the task himself. He sets out with endeavouring to establish a gradation among the causes which operate in producing motion. The simplest of these is the force of impulsion; that of gravitation appears to him less simple; and still less so those of electricity and magnetism. The principles which regulate chemical affinities are more complicated, as well as those which are concerned in the crystallization of bodies. But the forces which produce the phenomena of living vegetables and animals are of a more refined order, and are all referable, according to Barthez, to a single cause, which he denominates the *vital principle*, or *principle of life*. Having established this dogma, he proceeds to discuss a variety of abstruse questions that have been agitated on the subject, such as whether the vital principle has an independent existence, distinct from the organized body which it animates; and whether it be a modification of the soul or rational mind. He gives an elaborate historical sketch of the opinions of philosophers from the earliest times respecting the nature of life, tracing the different sentiments entertained by the followers of Aristotle and Descartes, together with the Stahlians and Boerhaavians, on the one hand; and those of Pythagoras, of Plato, and the sect of Stoics, on the other: the former not acknowledging any principle of life distinct from ether matter or mind; and the latter admitting such a principle attached to the living body. A third class

VOL. II. PART I.

of philosophers is noticed, at the head of which he places Bacon, and with which he associates Leibnitz, Cudworth, Van Helmont, and Hoffman, who have recognised the existence of a vital power different from the ordinary physical properties of matter, and at the same time totally distinct from the soul. After expending much useless argument in refutation of the Stahlian doctrine of the identity of the vital with the thinking principles, and devoting a long chapter to the consideration of doubts as to our means of deciding the question, he shows himself strongly inclined to the belief that the principle of life is something which has a separate existence, distinct from any modification, either of matter or of mind. There is little doubt, indeed, that this was his firm persuasion, as he reasons from it in many parts of his work, though he seems averse to declare it, without qualification, while he is discussing these questions. Having thus *personified*, as he very aptly expresses it, this new principle of life, he appeals to it for the solution of every difficulty. It is the master key which unlocks every secret, and renders all the operations of the living animal body perfectly intelligible. Irritability and sensibility are at once the direct effects of this universal agent. All the modifications of these properties, and, in a word, every phenomenon of life, which is not obviously the result of physical laws, are but so many immediate operations of the vital principle. To this fertile source he refers not only the ordinary muscular contractions, but also the slower and less sensible motions which take place in the iris, in the vascular system, and, in general, in those parts in which no muscular structure can be discerned: effects which he attributes to the tonic power of the vital principle. He contends for the existence of another power in the fibres, still derived from the same source; namely, the power of elongation, after they have been contracted; a power which he thinks quite distinct from the other mechanical properties of the fibre, and of which the operation is exemplified in the dilatation of the pupil, the extension of the corpora cavernosa, and of the nipples, and in the diastole of the heart itself. He plumes himself more particularly upon his supposed discovery of a new species of force, distinct from the muscular power, which he terms the *force of fixed situation*, and of which he infers the existence from the circumstance of the tendo Achillis being ruptured, and of the *patella*, and head of the *os calcis* being fractured, on some occasions, by an apparently slight exertion. He avails himself of this principle, also, to explain the phenomena of *tetanus*, and other spasmodic affections.

In a subsequent part of the work, he labours to establish the identity of sensibility and irritability; or, at least, the ultimate connection which subsists between them, and the dependence of both upon the immediate and direct operations of the vital principle. He endeavours to prove, that both the sensitive and moving powers are exercised in the circulating fluids of the body; and adduces, in support of this opinion, many of the arguments brought forward by Mr Hunter in proof of the vitality of the blood. On the subject of secretion, implying processes which have been hitherto enveloped in so much darkness,

T

Barth.

and of which the explanation has in vain been sought for on mechanical and chemical principles, he is very brief; as it is the peculiar advantage of his theory, like the sword of Alexander, to cut through every knot that bids defiance to ordinary powers of unravelling. Secretion, being inexplicable by any of the hitherto known laws of nature, is, of course, simply the effect of the vital principle. The phenomena of animal heat were in danger of being at once consigned to the same Proteus-like power, which could operate every possible diversity of effects. But chemistry had, in this instance, interposed some plausible theories, which must first be set aside; and Barthez is at great pains to state the reasons of his dissent from the received doctrines on this subject, and of his disbelief in the existence of caloric. He prefers the hypothesis which supposes heat to be a mere quality, excited by motion; and generated accordingly, in living animals, by the intestine motions of their fluids, and the friction of the solids against each other; and the cause of these motions and frictions being unknown, it followed, as a necessary consequence, that they must arise from the operation of the vital principle. Respiration he considers as a cooling or moderating process, and as useful, also, in exciting throughout the system the tonic actions; but all these actions and agitations of the fibres, and these intestine motions of the fluids, are still regulated by the vital principle, which adapts them to variations of climate, and other external circumstances of temperature.

Amidst these vague and unprofitable speculations, his work contains a great store of facts, which are often instructive, though sometimes they expose the credulity of the author. He has collected, for example, a number of curious particulars relative to the operation of different poisons on different animals; but intermingles with these well attested facts, many idle tales respecting the bites of rabid or enraged animals, in which the peculiar manners of the animal were communicated to the human species. Thus, he quotes instances of men barking or attempting to bite in hydrophobia; of some mewing like cats, after having been bitten by these animals; and of others, again, who flapped their arms, and crowed like cocks, after receiving the bite of one of these birds.

A large portion of the work is dedicated to the consideration of Sympathies, which he distinguishes from what he terms Synergies; defining the latter to be the connection, whether simultaneous or successive, of the vital forces of different organs, so as to constitute a function or a disease. He divides sympathies into three classes, according as they occur between organs having no visible relation to each other, those which have similar structures and functions, and those which are united by an intermediate texture, or by receiving the same set of vessels or nerves. His chapter on Temperaments is ably drawn up; and he discusses well the comparative influence of physical and moral causes in modifying the human temperament, and the changes produced by age, and the approach of death. He explains the operation of the more usual causes of death; and enters into a comparison of the mutabi-

Barthez.

lity of different seasons and climates; and concludes, from several facts and arguments, that the actual cessation of life is, in general, not accompanied by any painful sensation.

The merit of Barthez, as a physiologist, is more conspicuous on subjects which admitted less of his being led astray by his proneness to indulge in abstract speculation, and his predilection for metaphysical refinement. The most favourable specimen of his talents is afforded by his *Nouvelle Méchanique des Mouvements de l'Homme et des Animaux*; in which, avoiding all discussion as to the cause of muscular motion, he traces the mode in which this force has been applied by nature, according to the principles of mechanism, in effecting the different movements of the animal machine. He examines the relative disposition of the bones and muscles, the structure of the articulations, and the general play and particular motions of the limbs. Borelli (*De Motu Animalium*) had given the first model of such a work; but Barthez has investigated the subject with greater care, and has extended his views to a much wider range of phenomena. He enters minutely into the consideration of a great variety of modes of locomotion, both in man and the inferior animals; for which he has amassed an immense number of facts; forming, altogether, a work which will ever remain a monument of his industry and superior abilities.

In consulting his writings on the practical branches of his profession, we again find ourselves bewildered in a labyrinth of speculations on the proximate causes of disease, and the *modus operandi* of remedies. In his *Treatise on Gout*, he adopts the principles of the humeral pathology, in addition to his own physiological doctrines concerning the force of fixed situation, or principle which retains muscular parts in their appropriate places independently of irritability. He states the proximate cause of this disease to be a specific gouty state of the habit; which he infers from the supposed influence he has observed from specific remedies, and especially *aconite*, in curing it. He defines the gouty state of the blood to consist in "an improper mixture of its component parts, which prevents, in different degrees, the natural formation of its excrementitious humours; so that these humours, being more or less altered, undergo a spontaneous decomposition, which causes the earthy substance to predominate in them." This earthy substance, or, in other words, gouty matter, is deposited upon the extremities, and thus occasions the paroxysm. His practice, on the whole, notwithstanding his adoption of theories now generally exploded, is tolerably judicious; though he shows but little discrimination in the analysis which he gives of the works of practical authors on this disease; and he seems to be strangely deficient in information as to the practice of English physicians. In other respects, his knowledge is accurate and copious; and the history he gives of several of the irregular forms of gout, and also that of sciatica, in which, however, he chiefly follows Cotannius, are deserving of praise.

In the preface to his *Nova Doctrina de Functionibus Naturæ Humanae*, he has given an excellent ar-

Barthes
Basedow.

range-ment of the general principles of the objects to be kept in view in the medical treatment of diseases. He treats of this subject more at large in his treatise *De Methodo Medendi*, published at Montpellier, in 1777, and also in the preface to his *Traité des Maladies Goutteuses*. He considers all the different methods and indications of cure as capable of being comprehended under three heads, the natural, the analytic, and the empiric. The natural methods have for their object to promote the spontaneous operations of nature tending to restore health, or, as they have been usually termed, the *vires medicatrices nature*. The analytic methods are those which proceed upon a previous analysis of the disease into the several simpler diseases of which it consists, or into their ultimate component symptoms, which are isolatedly and successively combated by means respectively suited to each. These are the more indicated, in proportion as the disease is more complex, and admits of being resolved into a greater number of elements. The empiric plan of treatment is directed to change the whole nature of the disease, by means of which experience has taught us the efficacy in analogous cases. These means are of three kinds; having either a perturbing, an imitative, or a specific operation: the first being such as, by producing effects of a different kind from those of the disease, tend to diminish or entirely suppress the latter (as when the paroxysm of an ague is prevented by the excitement of a strong sudorific or cathartic operation); the second, such as produce effects analogous to those which nature herself employs for the cure of the disease; and the third, those whose salutary operation is known in no other way than as the direct result of experience.

The writings of Barthes appear to have had considerable influence in overthrowing many of the crude and preposterous theories which had prevailed in the schools of medicine; and, however he may have been seduced from the path of genuine philosophy by an excessive disposition to generalize, and an overweening fondness for abstruse speculation, he still deserves the praise of being an original thinker, and of standing pre-eminent among his contemporaries for the courage with which he shook off the trammels of authority, in a university where it had ruled with despotic sway, and where the dogmas of antiquity were held in peculiar reverence. (w.)

BASEDOW (JOHN BERNARD), a celebrated German writer, born at Hamburg, September 11, 1723, was the son of a hair-dresser. Ill treatment made him abandon his father's house. A physician, in a neighbouring village, took him into his service, and shortly after persuaded him to return home to his father. Being placed in one of the lower classes of the college of St John, the severity of his masters rendered him harsh and violent himself. Forced to submit to a slow and rigorous method of study, he contracted a dislike to patience and regularity, which exercised a marked influence over the whole course of his life. Poor but intelligent, he often performed their tasks for his school-fellows, who could afford to pay for it; and they, in return, invited him to their parties of pleasure, which contributed to those habits of irregulari-

ty by which his health and reputation often suffered. Basedow. In 1744, Basedow went to Leipsic to study theology. He gave himself up entirely to the instructions of the professor, Crusius, and the study of philosophy. This, at first, made him sceptical in theology; a more profound examination of the sacred writings, and of all that relates to them, brought him back to the Christian faith; but, in his retirement, he formed his belief after his own ideas, and it was far from orthodox. Having returned to Hamburg, he lived there without any employment till 1749, when M. de Quaalen, privy-counsellor of Holstein, appointed him preceptor to his son. Basedow now began to apply himself to the subject of education. At first, he would not teach his pupil Latin otherwise than by talking with him in Latin; and he wrote a dissertation on this subject, published at Kiel in 1751, *In usitata et optima honestioris Juventutis erudiendæ Methodus*. In 1753, he was chosen professor of moral philosophy and belles-lettres in the academy of Sorocø, in Denmark. Here he published, in 1758, his *Practical Philosophy for all Conditions*, in two volumes (Copenhagen and Leipsic, second edition, in 1777), which contained many good observations on education in general, and on that of girls in particular; but he advanced in it opinions by no means consistent with Lutheran orthodoxy; so that the Count Danneskiold, superintendent of the academy, took his place from him, and removed him to the school of exercises at Altona. Basedow still continued to devote himself to theological studies. In 1764, he published his *Philalethes, or New Considerations on the Truths of Religion and Reason, within the Limits of Revelation*, two volumes in 8vo. The magistrates of Altona forbade the reading of this work. He was not allowed any longer permission to print his writings at Hamburg or Lubeck; the communion was prohibited to him and all his family; and the common people were on the point of stoning him. Basedow, however, who was convinced of the truth of his opinions, displayed prodigious activity in defending them. He wrote his *Methodical Instruction in Religion, and the Morality of Reason*, Altona, 1764; his *Theoretical System of sound Reason*, 1765; his *Essay on Free Dogmatism*, Berlin, 1766; his *Extracts from the Old and New Testament*, and his *Essay in favour of the Truth of Christianity*, in the same year. The last of these works he particularly valued himself upon, because he there founds the evidence of Christianity chiefly on its moral purity. In these, and other works, he, however, maintained several heterodox opinions; as the non-eternity of future punishments,—the inequality of the three Persons of the Trinity,—the insufficiency of the atonement for our sins by the death of Jesus Christ, &c. Constantly persecuted in his theological career, he would have fallen the victim of his incautious zeal, if the Count de Bernatoff, minister of state, and J. A. Cramer, another officer of the court of Copenhagen, had not taken him under their protection. He left off giving lessons, without losing his salary; and, towards the end of 1767, he abandoned theology to devote himself with the same ardour to education, of which he conceived the project of a general reform in Germany. He began by publishing *An Address to the*

Basedow. *Friends of Humanity, and to Persons in Power, on Schools, on Education, and its Influence on public Happiness, with the Plan of an Elementary Treatise on human Knowledge*, Hamburg, 1768. He proposed the reform of schools, of the common methods of instruction, the establishment of an institute for qualifying teachers; and solicited subscriptions for the printing of his *Elementary work*, where his principles were to be explained at length, and accompanied with plates. For this object, he required 5050 crowns. The subscriptions presently mounted up to 15,000 crowns: the Empress of Russia, Catherine II. sent a thousand crowns, the King of Denmark nine hundred. In 1770 appeared at Altona the first volume of his *Method for Fathers and Mothers of Families, and for the Chiefs of the People*; and six months after, the three first parts of his *Elementary Treatise*, in 8vo, with 54 plates. This work, which was praised in all the journals, was translated into French by Huber, and into Latin by Mangelsdorf; but Schlozer, in the German translation of the *Essay on National Education*, by M. de la Chalotais, accused Basedow of having omitted in his plan various branches of science, and of having had in view only a pecuniary speculation. Basedow, in despair, offered to return the price of his book to those who were not satisfied with it. Only one man, a Swiss, demanded his subscription. Encouraged by the success of the *Treatise*, our author continued to write other works on the same subject, and on the same principles; among others, his *Treatise on Arithmetis*, 1773, and *Elements of pure Mathematics*, 1772. His *Agathocrator, or the Education of Teachers to come*, 1771, procured him a medal from the Emperor Joseph II.; and the visits which he made to Brunswick, to Leipsic, Dessau, Berlin, and Halle, to inquire into the state of public instruction, having enabled him to enlarge and correct his ideas, and convinced him that his *Elementary work* contained many erroneous and hasty assertions, he published a new and improved edition of this work in 1774. The same year, he published his *Legacy for Consciences, or Manual of natural and revealed Religion*; a work which he composed in order to make known the real state of his religious opinions, and to clear himself from the imputation of wishing to found a new sect. In his travels, he had been well received by the Prince of Anhalt-Dessau, who promised him his protection. From that time, he had resolved to establish an institute for education at Dessau, and to apply his principles himself in forming disciples who might spread them over all Germany. Little calculated, by nature or habit, to succeed in an employment which requires the greatest regularity, patience, and attention, he, however, engaged in this new project with all his accustomed ardour. The name of *Philanthropinon* appeared to him the most expressive of his views; and he published at Leipsic in 1774 a pamphlet, entitled, *The Philanthropinon founded at Dessau*, containing the details of his plan. He immediately set about carrying it into execution; but he had few scholars, and the success by no means answered his hopes. The institution, badly managed, became the theatre of the quarrels between Basedow and the masters who taught in it

under his direction. The assistance of the celebrated Campe, a journal which they both composed together under the title of *School Dialogues*, from 1777 to 1779, and a public examination which went off with éclat, gave a transient splendour to the *Philanthropinon*; but in a short time Basedow quarrelled with Campe, made complaints against his Prince, quitted and returned to the care of the institution; and exemplifying in his conduct the effects of coarse manners, and bad temper, was at length drawn into the most scandalous scenes in his disputes with Professor Wolke, his former coadjutor. This institution was finally shut up in 1793. Basedow for some time had given up all thoughts of education; he returned to his old theological inquiries, and residing sometimes at Magdeburgh, sometimes at Halle, sometimes at Leipsic, he took part in the famous controversy excited in Germany by the *Fragments of Wolfenbütel*, an anonymous posthumous work of Reimarus, published by Lessing. Doctor Semler having written a pretended refutation of the *Fragments*, Basedow, without difficulty, exposed the ill intentions of the author, who secretly attacked the cause he affected to defend; and, with his usual vehemence and frankness, called upon Semler to declare himself openly, offering to indemnify him with his fortune, if this public declaration should prove prejudicial to him. Semler made no reply, and Basedow wrote on. He published his work entitled, *Jesus Christ, the Christian World, and the small Number of the Elect*, in 1784; and the year following, returning to the study, which had divided his time and his powers with theology, he gave the public his *New Method of Learning to Read*, which he employed with success in two schools of little girls at Magdeburgh; and in this occupation he passed four hours every day for some time previous to his death, which took place in this city, July 25, 1790. He died with Christian firmness and resignation, and desired that his body might be opened, wishing (to use his own words) to be still useful to his fellow-citizens after his death. In 1797, a monument of marble was erected on the spot where he was buried.

To manners unpolished and abrupt, he joined gross habits; he was fond of wine, of which he drank to excess; in short, with a character in itself unamiable, he seemed, by his conduct, sometimes to take pains to render his services of no use, and his virtues of no account. Nothing can give a better idea of him than what he says of himself: "The sagacious reader will discover by my writings, that I have been especially called to serve the cause of truth and humanity, in following a path hitherto unknown. My opinions have succeeded one another, as has been seen. I have been at different times Lutheran, sceptic, infidel, a friend to natural religion, a convert to Christianity, a Christian with paradoxical sentiments, and more and more heterodox. In me has been seen a thinker tormented within by his own reflections, and a writer tormented from without, because he has been at one time hated, at another misunderstood. Bold and enterprising in my actions, I have always seen, with a faltering heart, the dangers

Basedow. which threatened me, and from which Providence has saved me in part. I have made little account of domestic happiness, of friendship, or society. I have suffered the penalty. Occupied in curing others, I have neglected the health of my own mind. Esteem is due to the sincerity of my opinions, rather than to my conduct. I desired ardently to make it perfect, but this would have required more perseverance and more attention than the meditation of abstract truths; accordingly, I have oftener been dissatisfied with myself than with others, with whom, however, for the same reason, I have been rarely satisfied. My heart has had little enjoyment of the consolations of religion, because every occasion led me into difficult researches, and thus weakened the force of sentiment. I regard myself as a man and a Christian, such as there are but few in the world, and such as it is not desirable that there should be many." This frankness, without affectation and without pride, induces us to honour the character of a man who has rendered some services to his country and his age. His work *On the Education of Princes destined to the Throne* has been translated into French by Bourjoing. A list of his writings may be seen in Meusel's *Lesson of German Writers*, from 1750 to 1800, and a farther account of his life in Schlichtegroll's *Necrology* for 1790. Goethe tells an anecdote of going a journey in company with him and Lavater, who fell into a violent dispute about the Trinity. Basedow consoled himself with the hope of getting some beer and a pipe of tobacco at an inn which he saw before them on the road. When they came to it, Goethe made the coachman drive on to the great chagrin of Basedow, to whom he excused himself by saying, that the sign of the inn was *two triangles*, and as he had such an aversion to one triangle (the scholastic emblem of the Trinity), he was afraid the sight of two might overcome him. This conceit, according to Goethe, pacified our anti-trinitarian divine.

Basedow, in his general writings, endeavoured to apply philosophy to practical purposes, and to give a more popular air to his reasonings than had been usual with his countrymen before his time. He held truth to be of little value without practice, and, indeed, he held its essence to depend chiefly on its utility. He considered external or speculative truth to be a very vague and doubtful thing; and that it is principally the consequences of things to the mind itself, that is, a *moral* necessity, which determines it to believe strongly and consistently on any point, so that that is true to each individual which makes the most lasting impression on his mind, and which he feels to be necessary to his happiness. Thus he regarded practical good as the test of speculative truth. He gave great weight to the principle of analogy, and founded the doctrine of a Providence on this principle. He considered common sense as one ingredient in philosophical reasoning, and rejected all systems which appeared to him to exclude it; such as idealism, the doctrine of monads, and a pre-established harmony. His favourite adage in his system of education, was *to follow Nature*. He wished the mind to be led to knowledge, virtue, and religion, by gentle means, instead of those of constraint and terror. Indeed, his

principles on this subject are very nearly the same as those of Locke and Rousseau; and he seems to have done little else than to have given currency in Germany to the same reasonings which those philosophers had taught before him in England and France. He insisted on the disuse of the preposterous and unhealthy dresses used by the children and their parents, such as stays, swaddling-clothes, tight bandages round the neck, the knees, &c. He recommended exercise and hardy sports as necessary to the health and activity of the body. He proposed to exercise the judgment by teaching a knowledge of things, and not merely to load the memory with words. He preferred the practical sciences to the speculative, the living to the dead languages, modern to ancient history, things which are more near to those which are more remote. In fine, most of his principles were in themselves sound and good, and have in fact exerted their influence on the actual progress of civilization; they were only erroneous from the excess to which he sometimes appears to have carried them; partly from the natural vehemence of his mind, partly from the natural tendency to paradox on the side of new opinions. Paradox, by exciting attention, and enlisting the passions, is perhaps necessary to contend against prejudice; common sense and reason are lost sight of by both parties during the combat; but in the end they prevail, if they have fair play allowed them. Thus, in the present instance, it is now generally admitted, that something besides the classics is necessary to a liberal education; nor is it thought requisite to arrive at this conclusion through the antithesis to the vulgar opinion of his day set up by Basedow, viz. that the classics are of no use at all in a rational system of education. (z.)

BASKET-MAKING. The earlier arts among mankind, in an uncivilized condition, are restricted to operations on materials which undergo slight and imperceptible changes; and implements are fabricated from substances almost in their natural state. The process of interweaving twigs, reeds, or leaves, is seen among the rudest nations of the world, and there is known even an inferior specimen of art among the natives of Van Dieman's Land, consisting of a bunch of rushes tied together at either end, which, spread out in the middle, forms a basket. But the sudden alteration of shape obviously renders this construction less convenient; whence the same and other tribes make a basket of leaves interwoven, and that so skilfully executed, that it retains either milk or water. A bundle of rushes spread out may be compared to the warp of a web, and the application of others across it to the woof, also an early discovery, for basket-making is literally a web of the coarsest materials. By experience these materials are refined and ornamented, and in the most improved stages of manufacture, neat and useful implements and utensils are produced. Scarcely any nation has been entirely ignorant of the art; and our ancestors in this island made baskets which, we learn, were carried to Rome either for use or ornament.

Basket-making, however, has by no means been confined to the fabrication of those simple and useful utensils from which its name is derived. Of old, the shields of soldiers were fashioned of wicker-work.

Basedow
Basket-making.

Basket-making.

work, either plain or covered with hides, and the like has been witnessed among modern savages. In Britain, the wicker boats of the natives, covered with the skins of animals, attracted the notice of the Romans; and Herodotus mentions boats of this kind on the Tigris and Euphrates. But there was this difference, that the former seem to have been of the ordinary figure of a boat, whereas the latter were round and covered with bitumen. Boats of this shape, about seven feet in diameter, are used at the present day on these rivers; and boats of analogous construction are employed in crossing the rivers of India, which have not a rapid current. At Hurrial, a town on the western side of Hindostan, the river Toombudra is not fordable from June to October; during which interval, round basket-boats are used to transport people, goods, and cattle, to the opposite sides. They are of all sizes, from three to fifteen feet in diameter, but shallow, not being above three feet in depth; and some will carry thirty men. They are of very simple construction: A number of pieces of split bamboo, twenty for example, are laid on the ground, crossing each other near the centre, and there fastened with thongs; the ends of the bamboos are then elevated by several persons, and fixed asunder at due distance by means of stakes, in which position they are bound by other long slips of bamboo. The latter are introduced alternately over and under the pieces first crossed, and tied at the intersections to preserve the shape. This being completed, beginning from the bottom to the centre, the parts above the intended height or depth of the basket-boat are cut off, and it is liberated from the stakes reversed, and covered with half-dressed hides sewed together with thongs. Nothing can be more expeditious or more simple than the fabrication and materials, of these vessels, if they merit that name. One may be made by six men in as many hours. Only two substances, almost always accessible, are used,—hides and bamboo. They are navigated either by paddles where the water is deep, or are pushed over a shallow bottom with long poles; and the passengers within are safely transported, being kept dry by planks and pieces of wood at the bottom. The basket-boats on the river Kristna, in the same country, are about twelve feet in diameter, and four feet deep. Whole armies are thus enabled to continue their march, and even heavy artillery has been in the same manner conveyed across rivers. Sometimes the boats are towed by bullocks fastened to them, and goaded on in the proper direction. We may also observe, that in different parts of the world, whole houses, cottages, fences, and gates, are formed of basket or wicker-work. On the Continent, a two horse carriage, called a Holstein waggon, of very considerable size, and fit to carry several persons, is composed solely of basket-work; the same is done in Britain with regard to the bodies of gigs; and an appendage of the stage-coaches is literally designed *the basket*; besides a vast variety of works on a smaller scale.

Materials employed.

In respect to the materials employed, besides those specified as belonging to the ruder nations, there are many which are equally the product of nature and art. Twigs, branches, straw, and whalebone, are all

of the number. The natives of some parts of South America make baskets simply of rushes, so closely interwoven as to hold water, and thousands of them are annually sold in the Spanish provinces. The Caffres and Hottentots are alike skilful with the roots of plants. Thus it does not belong to Europeans to rival an uncivilized tribe in the exercise of a simple art. But of all materials, osiers or willows are in most general use.

Basket-making.

Osiers, employed for basket-making, are either taken entire, cut from the root, split asunder, or stripped of their bark, according to the work to be produced; but in the latter case, they are previously soaked in water. The stripping is performed by drawing the willows through an iron-edged implement called brakes, which removes the bark, and the willows are then cleaned, so far as necessary, by the manual operation of a sharp knife. Next they are exposed to the sun and air, and afterwards placed in a dry situation. But it is not less necessary to preserve willows with their bark in the same manner, for nothing can be more injurious than the humidity inherent in the plant; and previous to use, they must be soaked some days in water also. The barked or white osier is then divided into bundles or faggots according to size; the larger being reserved to form the strong work in the skeleton of the basket, and the smaller for weaving the bottom and sides. Should the latter be applied to ordinary work, they are taken whole, but for implements of slight and finer texture, each osier is divided into splits and skains; which names denote the different degrees of size to which they are reduced. Splits are osiers cleft into four parts, by means of a particular implement employed for that purpose, consisting of two edge tools placed at right angles, whereby the rod is longitudinally divided down the pith. These are next drawn through an implement resembling the common spoke-shave, keeping the grain of the split next the wood or stock of the shave, while the pith is presented to the edge of the iron, which is set in an oblique direction to the wood: And in order to bring the split into a shape still more regular, it is passed through another implement called an upright, consisting of a flat piece of steel, each end of which is fashioned into a cutting edge, like that of an ordinary chisel. The flat is bent round, so that the two edges approach each other at a greater or less interval by means of regulating screws, and the whole is fixed in a handle. By passing the splits between the two edges, they are reduced to skains, the thickness of which is determined by the interval between the edges of the tool. All the implements required by a basket-maker are few and simple: they consist, besides the preceding, of knives, bodkins and drills for boring, leads for keeping the work steady while in process, and where it is of small dimensions, a heavy piece of iron, called a beater, which is employed to beat the basket close as it is augmented. Thus a basket-maker has this great advantage over many other artificers, that he can establish himself in his profession at the most inconsiderable expence either for tools or materials.

Osiers for Basket-making.

An ordinary basket is made by preparing the requisite number of osiers, and preserving their length considerably greater than that of the finished work.

Method of Basket-making.

Basket-making.

They are ranged in pairs on the floor parallel to each other, at small intervals, in the direction of the longer diameter of the basket; and this may be called the woof, for, as we have said, basket work is literally a web. These parallel rods are then crossed at right angles by two of the largest osiers, with the thick ends towards the workman, who places his foot upon them; and weaving each alternately over and under the parallel pieces first laid down, they are by that means confined in their places. The whole now forms what is technically called the slat or slate, which is the foundation of the basket. Next, the long end of one of the two rods is taken, and wove under and over the pairs of short ends all round the bottom, until the whole be wove in. The same is done with the other rod; and then additional long osiers are also wove in, until the bottom be of sufficient size, and the woof be occupied by them. Thus the bottom, or foundation on which the superstructure is to be raised, is finished; and this latter part is accomplished by sharpening the large ends of as many long and stout osiers as may be necessary to form the ribs or skeleton. These are forced or plaited between the rods of the bottom, from the edge towards the centre, and are turned up in the direction of the sides; then other rods are wove in and out between each of them, until the basket is raised to the intended height, or, more correctly speaking, the depth it is to receive. The edge or brim is finished by turning down the perpendicular ends of the ribs, now protruding and standing up over each other, whereby the whole are firmly and compactly united. A handle is adapted to the work by forcing two or three osiers sharpened at the end, and cut to the requisite length, down the weaving of the sides, close together; and they are pinned fast, about two inches from the brim, in order that the handle, when completed, may be retained in its proper position. The osiers are then either bound or plaited, in such fashion as pleases the taste of the artist.

This is the most simple kind of basket; from which others differ only in finer materials, and nicer execution; but in these there is considerable scope for taste and fancy, and implements are produced of extreme neatness and ingenuity in construction. Some are formed of twigs or straw entire; others of sections, split of various thickness, coloured, plaited, or plain; and baskets of endless variety in size, figure, and texture, are fabricated according to the artist's inclination. The skains are frequently smoked and dyed, either of dull or brilliant colours, and, by intermixing them judiciously, a very good effect is produced.

From the simplicity of this manufacture, a great many individuals, independent of professed basket-makers, are occupied in it; and, fortunately, it affords employment to the blind in the several asylums established for their reception. Not that persons suffering privation of sight are incapable of more ingenious and delicate mechanical exercises; but the facility of teaching and acquiring the principles of basket-making being alike obvious, is one of the strongest recommendations in its favour. At Liverpool, where there is an asylum of this description, the art is practised with success; and in the city of

Edinburgh, a number of the blind find employment of the same kind, in the asylum established there.

The best materials for basket-making have been principally imported into Great Britain from France and Holland; but the duration of the war induced the inhabitants of this country to endeavour to obtain a supply at home. Cultivation of the osier was imperfectly understood in England, and in Scotland it scarcely received any attention whatever; whence, as a suitable encouragement, that patriotic Society, whose notice is specially directed to the improvement of arts and manufactures, some years ago, offered premiums to those cultivators who should raise the greatest quantity, not being less than 6000 plants on an acre.

It became an object with such cultivators to ascertain, not only the quantity that could be obtained, but the quality of the produce, which was of the greater consequence, as many plants, passing under the general name of osiers, and even possessing their external characters, are ill adapted for the work intended. But considerable light has been thrown on the subject by Mr Philipps of Ely, who was early rewarded by a premium on account of the utility of his observations. He remarks that the osier is a species of salix, of which there are many varieties; and these may be comprehended under two classes; the first containing nine or ten species. None, however, excepting one, the grey or brindled osier, is of use. This, in common with the others, has a light coloured leaf, but is distinguished by the bark being streaked with red or blood colour; and it is of late introduction into Britain on the Isle of Ely, where the observer's experiments seem to have been chiefly made. It grows vigorously, is very hardy and tough, and bleaches well. All the others of the same class prefer a wet soil, where they grow quickly and large, and will flourish even in the most barren kind of peat; but they are coarse and spongy, have a thick pith, and are perishable. Nevertheless, they are sometimes used for coarser workmanship, and are profitable to those who live in the vicinity of places where there is a great demand for osiers, and cheap conveyance. During the interruption of continental intercourse, they were much resorted to by basket-makers; but their inferiority has brought the English baskets into disrepute in foreign markets. The second class, according to Mr Philipps, contains four or five different species. One of these, the Welsh willow, is very tough and durable, but not of a favourable colour; there are two varieties, red and white; the former of which is preferred, and forms part of every plantation, from its particular utility in tying up the bundles of willows, after they have been barked or whitened. Their bitterness is such as to be a protection from the depredations of cattle. Besides these, there are the west country Spaniard, the new willow, the French, and red Kent willow. The first has been superseded by others of superior quality, but experience proves that an acre will carry 2000 plants more of them, with greater advantage, than of some in higher repute. But the best of all is esteemed the French willow; especially as being most adapted for smaller and finer work in baskets, fans, hats, and other light articles. It is rather of slow growth,

Basket-making.

Progress in the Cultivation of Osiers.

Utility of this Manufacture to the Blind.

Basket-making.

but extremely taper, pliant, close grained, tough, and durable. Great quantities of it are always imported from the continent, its culture being more neglected here than that of others; however, it must be distinguished from a species resembling it, which is characterized by the leaves snapping in a manner as brittle as glass, when drawn through the fingers. Plantations of the French willow have been strongly recommended, as forming a useful commodity, and being always in demand. Having attained the requisite maturity, all willows are cut over and made up into bunches in iron hoops, an ell or 40 inches in diameter, for the manufacturers, and are sold, either in this way or in loads; the price being subject to fluctuation, according to scarcity or abundance.

In regard to the cultivation of osiers, very different opinions prevail; originating, it is probable, from too limited experiments, combined with the diversity of soil and climate. Mr Philipps, whose opinions are entitled to attention, conceives, that autumn and not spring is the most proper season for planting willows; the stagnation of the juices, he considers the true criterion whereby to regulate the period, but not on account of the set so much as on account of the trunk; for if the shoot be severed when the sap is in circulation, the parent plant bleeds to death. The osiers which he planted in the first week of October, he found to have struck roots about Christmas, though there was no external sign of vegetation. In prosecuting this subject, Mr Philipps observes, that he made a plantation in autumn, and filled up part of the ground which was vacant in the following month of March with additional sets. The latter were the further advanced in May, but in June the autumn plants had the advantage, and continued growing well, while many of the others died. In summer, he remarks, "when the fibres have been formed before the winter, or when a tendency to form them has been observed by the swelling of the bark, and particularly at the eye, the plant is enabled to charge itself with a sufficient portion of the juices to answer the demand of spring." Therefore, he concludes, that the proper rule is to plant as early in autumn as the shoots may be cut, without injuring the parent stock. The cultivator lays out the ground in beds or burrows 18 feet broad, digging ditches nine feet wide on each side. The upper surface of the ditches, to the depth of 14 inches, is thrown on the beds, and the remainder of what is excavated from them is used for turf or fuel. The beds, now consisting of about two feet and a half thick of solid earth above the surface of the substratum of peat, are planted in the following autumn, and produce good crops.

Soil best suited for Osiers.

Experiments have been made by various cultivators respecting the suitableness of different soils, and after having borne different kinds of grain. Mr Sheriff has related a profitable mode of culture practised by him in Scotland; and also makes some judicious observations on the subject in general. He remarks, that the finest and most valuable twigs can be procured only from land cured of chilling, weeping springs; and if the soil is not of considerable thickness, it must be rendered so by manure. Moderate moisture is favourable to the production of fine twigs,

Basket-making.

but water constantly stagnant is ruinous. He proposes to make the cuts or shoots from 15 to 17 inches long, and to allow four or five inches to remain above ground, to be cut over by the surface of the soil, when the heads of the stocks shall, in a series of years, have become too bushy. By this operation, the vigour of the plant is renewed in the most decided manner. Mr Sheriff forgets, however, that, in the time he mentions, a much greater protrusion from the earth will have taken place by the simple vegetation of the plant than necessary to leave room for cutting off the head. It is necessary, in his opinion, to trim and dress the stocks from decayed wood, and to retain only as many buds on each as the plant may be expected to bring to perfection in length and strength of shoot. Thus the superabundant stumps of old wood are cut down, the weakest shoots extirpated in November and December, or March and April, and seldom more than two buds should be left on those selected to stand and produce the next summer's growth. He considers the leading errors of those who have attempted the cultivation of osiers to consist in employing improper soil, peat earth, perhaps, or poor bogs; and also in defective preparation of the soil, though suitable in other respects. Failure may, besides, arise from planting bad or useless species of osiers; putting too few cuts in the ground; neglecting their subsequent culture, particularly during the first spring and summer after plantation; allowing the shoots to be cut over after Christmas, and before the middle of March, which may admit of the stocks being much weakened by hard frosts succeeding heavy rains, immediately after the twigs have been cut, and before the wounds from the knife have healed. By pursuing a system analogous to what is here exposed, he calculates the profits of an acre of osiers at about L. 18, 10s.; and he mentions that he contracted to receive a sum between L. 220 and L. 250, for the produce of twelve statute acres and a half. It does not appear, however, that this was an annual crop, and it is rather to be inferred that willows of several years growth formed part of it. Mr Sheriff's experiments and observations were rewarded with the gold medal of the Society for the Encouragement of Arts and Manufactures. Another cultivator, Mr Wade, calculated his profits on fourteen acres, which were planted with 12,000 sets each, at intervals of 26 inches by 10, as amounting to L. 10 per acre.

Among the experiments on the quality of soil may be instanced a plantation made in spring, of large cuttings, 18 inches long, thrust so far into the earth as to leave four or five inches protruding. Part of the ground had been in wheat after summer fallow, and part, which was also planted, had been sown with grass seeds. The plants made a more vigorous shoot in spring than at any subsequent period, and but few failed of the whole. Those which succeeded the wheat produced the best osiers, and those which were planted among the grass seeds the worst. Both stood on a strong clay soil. From the difference seen here, it has been concluded, that, as the elements ground produced the best crop, summer fallowing would be advantageous. Another example is given:

Basket-making.

where, of 350 sets planted in garden ground, of which the soil was clay, 341 succeeded, producing, in the first year apparently, a bundle 38 inches in circumference, and some of the osiers above 10 feet long. They were planted in the latter end of March, arranged in rows, between which was sown a crop of beans. Both the interval separating the plants and their age are arbitrary, as is also the extent of the plantation, and we must likewise add the quality of the soil, for experiments have not been made on a sufficient scale to determine the fact. The most superficial observer cannot fail to have remarked the comparative slenderness of all plants crowded together, and the superior strength of those apart from each other. The sets of osiers, for several reasons, should be inserted in regular rows: their age does not appear important, and no where is a more vigorous crop produced than from the root of the oldest tree deprived of its trunk. In general, previous preparation of the ground is profitable; and plantations may thence be formed, which are to be annually cut over for baskets and such light utensils; but the shoot is allowed to grow two, or even four years; if strong rods are required for larger and coarser workmanship. The rapidity and certainty with which this plant vegetates, preserves it in a manner under absolute control, and adapts it particularly for a variety of mechanical purposes. Many cultivators recommend deep insertion of the shoot into the ground; but here there is a limitation; for if too deeply inserted, the vegetation will be less vigorous. At the same time, the powerful tendency to vegetation in a willow is rather an exception to ordinary rules, and although the lower part be injured, roots may spring nearer the surface. But it is not to be overlooked, that if a tree be transplanted into too deep a pit, the root, instead of striking out new fibres, remains inactive, and the tree withers and decays; or if seeds be deposited too deep in the earth, no vegetation will ensue; whereas, even those on the surface will put forth a radicle, and establish themselves there. In the former case, they either lose the germinative faculty, or are destroyed; but, if a tree be transplanted into a shallow pit, the root will spread, and the whole exhibit luxuriant vegetation. These are facts which demand greater attention than they usually receive, and the depth at which the shoots of osiers are inserted should be carefully observed. Nevertheless, we must repeat, that it does appear deep insertion is not equally noxious to them as to other plants.

It is commonly understood, that willows flourish no where but with abundance of water. Undoubtedly, adequate humidity is very essential; but this general position is quite erroneous, as experiment and observation daily testify. Willows growing in water have almost invariably a sickly aspect, few strong or healthy scyons spring from them, and their vegetation is never so vigorous as when they are at some distance from it. Every plant has a predilection for a particular place, where the conditions of its aliment and vegetation concur. The willow requires a considerable degree of humidity, though it will also be seen vigorous on drier soils; but the vicinity of water is an essential quality in selecting a suitable

Basket-making
||
Bathing.

spot for a plantation. The purposes to which the plants are to be applied must be considered, and the circumstances of their growth so regulated, that they become suitable and adapted for them. There is little doubt, that, with due notice and consideration, this plant may receive great amelioration by culture.

All plantations must be well fenced against cattle, as the willow, both shoot and leaf, is a favourite kind of food; and as some particular caterpillars infest the plant at certain seasons of the year, stripping it totally bare and injuring its vegetation, care should be taken to remove them as effectually as possible. (s.)

BATHING. In addition to the historical, economical, and physical details respecting the practice of Bathing, which have been inserted in the body of the *Encyclopædia*, we find many investigations in the works of some of the latest authors, relating to its medical and physiological effects, which require to be attentively considered.

Medical and Physiological Effects of Bathing.

A methodical arrangement of these effects, referred to the respective divisions of therapeutic agencies, would be of great use in enabling us to attain a distinct idea of their nature; but such an arrangement is, in fact, a matter of extreme difficulty, for two reasons; *first*, Because the temperature, the continuance, and the impregnation of the bath, are capable of being so varied, as materially to vary the nature of the remedy, without any distinct limit between its different forms; and, *secondly*, Because the classes of medical agents, to which several of these effects belong, are by no means distinctly defined; to say nothing of the additional complexity arising from the division of the effects into immediate and remote, which is often extremely important. The remote effects, however, being of a more general nature, and relating chiefly to the improvement or deterioration of the actions of the whole system, it is only the immediate effects that require to be accurately analyzed and distinguished; and these we must endeavour to reduce to some methodical classification of therapeutic powers.

Baths, as depending on water, have been naturally referred to the class of *diluent* remedies, in which water is comprehended; and they have sometimes even been recommended as *nutrients*; they may also act as *excitants* of cutaneous sensation; as stimulants, or rather *calefacients*, increasing the velocity of the circulation of the blood; as *sudorifics*; as *diuretics*; as "sorbertia" or *sorbefacients*; as refrigerants or *astringents*; as *tonics*; and as *retardants* of the pulse, a capacity in which some would call them relaxants; while they seem in many cases to be useful as antispasmodics, or to relieve certain nervous affections, by something like a *narcotic* or *sedative* power. We might also refer the mechanical effect of ablution, in removing the natural secretions of the skin, to the dietetic *habits* conducive to the preservation of health; but this process, though highly necessary for our comfort, is perhaps less essentially important to health, than has often been imagined; and, in some particular cases, the practice of the very frequent removal of the unctuous and volatile secretions of the skin has even appeared to be injuri-

Bathing. ous, and to occasion indolent tumours of the absorbent glands belonging to the parts concerned.

If we admit that baths are ever, strictly speaking, either *diluent* or *nutrient*, we must suppose the cutaneous absorbents to be the channels of these actions; and the majority of authors, both ancient and modern, have certainly considered the skin as imbibing, with great facility, not only water, but also any kind of substance capable of being dissolved in it; nor is there any doubt that, under some circumstances, the cutaneous absorbents have been found to possess such a power in a certain degree; but Mr Séguin and Dr Currie have shown that, in common cases, very little or no effect is to be expected from this absorption; * that the strongest medical agents, when dissolved in the water of a bath, exhibited no operation on the system while the skin was entire; and that no perceptible advantage was obtained from a continued immersion in a bath of nutritive fluids, notwithstanding the extreme exhaustion of the system, in a case of completely obstructed deglutition; and they suppose that where weight has been gained during immersion in a bath, the absorption occasioning its increase has been principally performed by the lungs, retaining the moisture, which they receive in abundance with the air inhaled.

The other immediate effects of bathing must depend on the contact of the fluid with the skin, either as simply moistening and softening the cuticle, or as *exciting* a peculiar sensation in the cutaneous nerves, whether of touch only, or of heat or cold, or, in some cases, of slight pain, where the skin has been previously in a state of irritation, especially if the water contains a saline impregnation; or, *lastly*, as altering the state of the circulation by any of these means, especially by the change of temperature; this effect being also often modified by the change of the position of the body, and by the distribution of the pressure or resistance which supports its weight throughout almost the whole surface, instead of its being confined, as usual, to the parts on which we sit or stand. The excitement of the nerves of the skin appears to be salutary in many cutaneous diseases, which are benefited by warm bathing, whether in fresh or in salt water, or in sulphureous or other mineral waters, as at Harrogate, and at Baden, and Pfeffer and Leuck in Switzerland; the bathers sometimes remaining whole days in the water for weeks together, until a peculiar efflorescence has appeared on the skin, and has again disappeared. † The mud baths in the north of Italy are of a nature somewhat similar, and are said to be of considerable advantage in some paralytic cases. But if we allow the truth of the opinion of Séguin and Currie, we must infer that there are few instances in which the effects of bathing on the system in general can depend much on the impregnation of the water; and we ought perhaps to attribute the acknowledged advantage of sea bathing in a variety of diseases, in great measure, to the mildness and equability of the temperature of the sea. It is true, that persons ac-

Bathing. cidentally wetted with salt water are but little liable to take cold; and this fact has been supposed to indicate some stimulant property in the contents of the fluid; but it may be explained, with greater simplicity, from the slower evaporation of salt water, which causes it to carry off heat much less rapidly than fresh, the cooling process being also retarded by the greater moisture of the sea air.

In order to determine how far any kind of bathing may properly be called a stimulant or *calesfacient*, we must consider what are the tests by which we judge of the increased rapidity of the circulation of the blood. The term *calesfacient* is, indeed, somewhat objectionable, as implying, that animal heat depends solely or principally on the motion of the blood, which is not, in the present state of our knowledge, the most probable opinion; and besides this etymological inaccuracy, the definition of the term, as implying an accelerated circulation, involves a considerable difficulty, since we have no means of ascertaining whether increased frequency of pulsation compensates, or not, in any particular instance, for diminished fulness and strength. On the other hand, the operation of almost all medical agents is such as to relieve us from this ambiguity in the application of the definition; for we can scarcely mention any remedy which materially accelerates the pulse, without, at the same time, increasing its strength. There are, indeed, many medicines which are often designated by the vague denomination of stimulants, and which have no effect whatever on the circulation, but either simply *awaken* the nervous energies in general, or *excite* local sensations of heat or pain, and this multiplicity of significations is a sufficient reason for rejecting the term from a correct classification. It happens, however, not unfrequently, that astringent and febrifuge medicines will reduce the frequency of the pulse, and increase its fulness; and it becomes necessary, for an accurate analysis of the operation of remedies which affect the circulation, to distinguish the *accelerants* of the pulse from the *augmentatives* and the *insensitives*, all of which may possibly be independent of the production of an increase of temperature; and this increase may also in some cases be produced, at least in the extremities and the superficial parts, and apparently also in the whole system, without any change in the circulation, by the operation of certain remedies, which might be called *thalptics*, if it were necessary to distinguish them as independent agents: and to these four classes we might add four others of an exactly opposite nature, which might be called *retardants*, *diminutives*, and *remissives* of the pulse, and *psychics*, or direct refrigerants; and the last four classes would belong to a general division of remedies comprehending those which lessen the force of animal actions; a division which it has not commonly been found necessary to establish, for any practical classification of the *materia medica*.

Now, it appears that a hot bath, of a temperature exceeding 98°, the usual heat of the human body,

* Currie's *Medical Reports on the Effects of Water*, 8vo. Liverpool, 1798, p. 244.

† *Marcard über die Bäder*, 8. Hanov. 1793. *Traduit par Parant*, 8. Par. 1801, p. 40, 41.

Bathing. will commonly act both as an accelerant and an augmentative of the pulse, but probably not as an intensive; it may, however, very properly be classed as a calefacient, if such a description of remedies be admitted. Dr Parr* says, that a bath of 100° rendered the pulse fuller and more frequent; but that, after the bath, it was slower than usual; at higher temperatures, the effects were still more marked; and in Marcard's experiments (p. 71) the results were nearly similar. Dr Haygarth observed (Marcard, p. 67), that in a bath of 114° the pulse was rendered more frequent, and the arteries were evidently dilated. In Finland, according to Martin (Marcard, p. 228), the vapour baths are usually heated to about 120°, and they often increase the frequency of the pulse from 70 in a minute to 110 or 120. Fourcroy mentions a bath of 66° degrees, which must have been of the centigrade scale, making 151° of Fahrenheit, and not 181°, as Marcard supposes (p. 216), which was followed, an hour afterwards, by a fatal apoplexy. Whatever exaggeration there may be in this report, it may still serve to explain to us the excesses which were frequently committed in the use of baths by the Greeks and Romans, and the pernicious effects attributed to them by the ancient physicians. Hippocrates observes (Aph. v. 16), that the too frequent employment of hot bathing causes a softness and debility of the muscles, a want of firmness of the nerves, and a dulness of the faculties, with occasional hæmorrhages and faintings, sometimes even terminating in death; and in the *Clouds* of Aristophanes, we have a mock defence of warm bathing deduced from the usual dedication of hot springs to Hercules, which implies a perfect confidence in the opinion of the pernicious tendency of the practice, accompanied, or followed, as it frequently was, by other indulgencies, to which it has too often given occasion. This traditional condemnation of hot bathing has been erroneously transferred by some of the moderns to warm or tepid bathing; and since it has been asserted by authors of high celebrity, that air above 60° will generally occasion a sensation of warmth, it seems to have been inferred that water above 60° must constitute a warm bath, and consequently produce enervating and debilitating effects. The fact is, however, that a bath below 100° is scarcely ever heating in any material degree; and even at 100°, the pulse, though somewhat accelerated, is often not at all augmented in fulness, nor are the subsequent effects materially different from those which usually result from an equal acceleration produced by any kind of moderate exercise. It is observed by Galen in his *Treatise on the Pulse* (Opp. Vol. III. p. 3. Ed. Bas.), that "baths, when moderately warm, cause the pulse to be full, and strong, and frequent; when excessively hot, small and obscure, but frequent and hard, sometimes, however, after a time, becoming slow, though still feeble." Of this retardation of the pulse in a very hot bath we have no experience in modern

Bathing. times; it is obvious, that what Galen calls moderately warm, we should at present term a hot bath; and probably his excessively hot baths somewhat resembled that which is mentioned by Fourcroy. "Cold baths," he says, "at first make the pulse slow and weak; afterwards, if they disagree, and produce torpor, the pulse remains weak; but if the bath is likely to strengthen the system, producing a salutary glow, then the pulse becomes full and strong, and natural in point of frequency."

It is, however, remarkable, that the cold bath not uncommonly renders the pulse very considerably more frequent at the first immersion; a circumstance which was particularly observed by Athill, † and which, notwithstanding Marcard's doubts, has been since fully confirmed by Dr Stock. ‡ This increase of frequency seems principally to depend on the painful sensation of cold occasioned by the first immersion, especially while it is incomplete; it is commonly very transitory, and is succeeded by a retardation, while the fulness of the pulsations is diminished from the first.

The sudorific effect of the hot bath seems to be, in great measure, the natural consequence of the acceleration of the circulation, and to be nearly proportional to this acceleration, being also favoured by the softening of the cuticle, and perhaps by the dilatation of the cutaneous exhalants. It is principally recommended in rheumatism, and it is also considered as conducive to the cure of some cutaneous affections; and when this effect is thought particularly desirable, it is usual to take the bath late in the evening, and to promote its operation by going into a warm bed immediately after it.

In considering these and other changes produced in the system by bathing, we must be careful to avoid the very common error of applying inaccurately and indiscriminately the laws of mechanical and physical agents to the effects produced in the animal economy. Some of the latest and best authors on therapeutics have talked of the expansion of the fluids contained in the vessels, in consequence of the elevation of temperature occasioned by the warm bath, and of the contraction of the vessels themselves by the cold bath, as if they were phenomena of the same kind, and simply opposed to each other. The truth is, that the mean temperature of all the fluids in the body is seldom elevated more than a degree or two by the effect of a bath of any kind; and even if the elevation were ten degrees, the expansion of all the circulating fluids would not exceed the bulk of a single additional ounce of blood or of water. The mechanical effect of cold, on the other hand, would immediately tend to lessen the tension of the vessels, by contracting the fluid contained within them more than the vessels themselves; but this effect would be scarcely more sensible than the former, even if we allowed that the general temperature might be depressed 10° or 12°, as it seemed to be in some of Dr Currie's experiments; and the actual contraction,

* *De Balneo, Med. Comm. Ed. i. 297, or Marcard by Parant, p. 66.*

† *On Cold Bathing, Marcard, p. 239; Med. Comm. Edinb. vi. 62.*

‡ *Medical Collections on the Effects of Cold, 8vo, Lond. 1803, App.*

Bathing. which is really observable in the superficial parts during immersion in the cold bath, can only be referable to the action of living powers, which fall decidedly under the description of involuntary muscularity. Dr Parry's late experiments have very clearly shown the existence of such powers, and exhibited their temporary and local action.* He found that, when the carotid of a ewe was laid bare, its circumference was 525 thousandths of an inch; "but it almost immediately shrunk, through the whole space which was exposed, so as to become in circumference only .470; at the same time, a portion of the artery, before the contracted part, and which had been more recently exposed, was .635; the pulse in the dilated part was very strong and full, that in the contracted part very weak and soft." Dr Parry has chosen to distinguish these effects from those which are observed in other muscular parts by a peculiar denomination; but the distinction appears to be perfectly arbitrary, and Dr Young, whom he quotes as denying the muscular powers of the arteries, on account of the chemical nature of their coats, has expressly asserted their muscularity, in contradiction to the conclusions of Bichât and Berzelius. (*Medical Literature*, 8vo, Lond. 1813, p. 502.) But by whatever term we choose to denote the effect, there is little doubt that an unusual degree of cold has a tendency to produce such a general contraction of the coats of all the superficial capillary arteries; and the diminution of their diameter must necessarily increase that part of the resistance to the blood's motion, which is derived from its friction against the sides of the vessels, and must, therefore, tend materially to lessen its velocity. Again, if the contractions of the heart are at all proportional in magnitude or in frequency to the quantity of blood entering it, and acting as a stimulus to its motions, it is not unnatural to suppose that its pulsations will be rendered feebler by the diminution of that quantity, occasioned by the increase of the resistance, and that the primitive retardation will be redoubled by the operation of this cause. At the same time, however, that the cutaneous vessels are contracted, those of the internal parts must necessarily be enlarged. Hence arises the sensation of oppression on the chest, with the sobbing or panting for breath, which generally occurs at the first immersion in cold water, from the fulness of the vessels of the lungs, and which is increased, in some measure, when the immersion becomes total, by the pressure of the water on the abdomen, and consequently of the contents of the abdomen on the diaphragm. From the same cause arises also the pulsation in the descending aorta, which has been observed to be much more distinguishable after swimming than at other times (*Medical Transactions*, Vol. V.); the internal vessels being distended so as to exhibit the effects of the heart's action more violently, and the heart itself beating with more than usual force in consequence of the exertion, while the contents of the abdomen are compressed, and are enabled, by the presence of the surrounding fluid, to transmit the pulsation very com-

pletely to the superficial parts, to which the hand is applied. The *diuretic* effect of a cold bath may be partly explained from a similar distension of the renal vessels, which must be favourable to the secretion of the kidneys; and if the same effect is sometimes produced in a hot bath, when the superficial vessels are rather dilated than contracted, it is in this case much less considerable than in the cold bath, and probably only takes place in consequence of the increased rapidity of the circulation, which affects the whole sanguiferous system.

The glow, which succeeds to the first sensation of cold, may be attributed in great measure to the increased sensibility of the nerves after a partial torpor, rendering them more susceptible of the sensation of heat, which is always relative to the actual temperature of the skin; but it appears, from Dr Currie's experiments, that there is also sometimes a real increase of heat as measured by the thermometer; and it is probable, that the causes concerned in the production of animal heat are called up into a more vigorous exertion, in a strong constitution, whenever they are required for the purposes of life; so that they first supply the superficial parts of the body during the immersion, with as much heat as is necessary to overcome the painful sensation of cold, and afterwards, by a continuation of the same action, occasion an actual elevation of temperature above the natural standard. Dr Currie found, that, during the affusion of a bucket of cold salt water on the heads and whole bodies of two healthy persons, no depression of temperature was observable; but in a minute or two afterwards, although they remained without motion, the mercury rose 2° : in a third person of a feebler constitution, although the temperature remained equally unchanged during the affusion, it sunk, in a minute after, half a degree. These effects seem to be almost entirely independent of any change in the state of the circulation, which must be rather retarded than accelerated, while the generation of heat is increased. It is true, that the heart might be called into more powerful action at the same time that the pulsation at the wrist became feeble, from the permanent contraction of the radial artery; but the action of the heart would still be exhibited by the carotids, undisguised by this modification; and the carotids have not been observed to beat more strongly in the cold bath than at other times, although Dr Currie has remarked, that when "the pulse could hardly be felt at the wrist," "the heart pulsated with great steadiness and due force:" a fact precisely analogous to Dr Parry's interesting experiment on the carotid of the ewe.

Warm baths may be classed with propriety among the most useful *sorbefacient* remedies; but it is not easy to decide, whether they are much more active in promoting absorption than other sudorifics, or than evacuants in general. When the weather deprives a valetudinarian of his accustomed walk, the bath often affords him a valuable substitute, increasing the appetite, and promoting the digestion; but too great an appetite, without muscular exercise, is

* *Experimental Inquiry on the Arterial Pulse*, 8vo, Bath, 1816, p. 41.

Bathing. sometimes an evil, and this may have been one of the causes of the inconveniences occasioned by an abuse of bathing. A warm bath has often been of advantage in promoting the absorption of dropsical fluids, especially when they are of limited extent, as in cases of partial anasarctous swellings; but the most important sorbefacient effect of bathing is exhibited in the cure of glandular diseases, for which sea water, whether in the form of a warm or a cold bath, has long been considered as a specific remedy; and there is no doubt that a residence by the sea side, with a judicious employment of bathing, and the occasional internal use of sea water, or of some equivalent remedy, has been of the most essential service to many constitutions, which have exhibited these symptoms of general debility and languid absorption; the tonic and sorbefacient powers of the remedy being happily combined, for invigorating and calling into activity the diminished energies of the constitution.

The refrigerant or *astringent* powers, both of warm and of cold bathing, have been abundantly elucidated by the late Dr Currie, who has introduced the remedy into general practice, as a febrifuge, especially in the form of cold or tepid affusion, with the most salutary effects. It is not easy to determine how far the contraction of the superficial vessels by the astringent powers of cold, and how far the *retardation* of the pulse; which may possibly be dependent on that contraction, are concerned in the advantage derived from bathing in fevers; but it is at least obvious that the remedy does not operate simply by the abstraction of heat, since the tepid affusion is often more rapidly successful in abating fever than the cold. We may also collect from the experiments of Marcard, that a bath at about 90° is more efficacious in abating the frequency of the pulse, than at any lower or higher temperature; and these facts appear to afford a very strong argument against the hypothesis, that the principal utility of the cold affusion depends on the sudden shock which is given to the nervous system. Dr Currie has frequently found the pulse reduced by a single cold affusion from 120 or 130 to 80 or 90, and the heat from 104° or 106° to the natural standard. But he very properly limits the employment of the remedy to those cases in which the temperature is considerably elevated, and the arterial system is in strong action, without local inflammation; and where there is less vigour in the system, he often employs the tepid instead of the cold affusion, or even contents himself with moistening the face and the extremities; for instance, in hectic fever, the hands and feet only, which he finds actually hotter than the rest of the body. A late writer on consumption has very justly remarked how much of Dr Currie's reasoning on the effects of cold bathing had been anticipated by Galen, although, for want of a thermometer, he had not been able to employ the remedy in fever with safety. "Bathing," says Dr Young (*On Consumptive Diseases*, 8vo, Lond. 1815, p. 135), "is very strongly recommended in the Method of Healing, and the process is very minutely described: first warm air is employed, next warm water, and then cold water, and lastly, the sweat is wiped off. When we are fatigued or dried up by exercise, the bath re-

Bathing. stores us to comfort, and defends us from fevers. A strong young man in the country will plunge into cold water at once when heated; and be much refreshed by it. Animals also wash themselves when they are hot, by a natural instinct, as they eat when they are hungry, and seek warmth when they are cold. In fevers, if we had sufficient powers of discrimination, we might probably sometimes derive material advantage from the use of the cold bath, without premising the hot; and some persons have been actually benefited by this remedy. But without a more intimate knowledge of diseases than we possess, we cannot generally venture on the practice; and least of all in hectic fever, where there is not strength enough to bear the shock. A stout young man, having a fever, in warm weather, without visceral inflammation, would bring on a salutary perspiration by bathing in cold water; and if he were in the habit of cold bathing, he might have recourse to it with the more confidence; but, for the hectic, it is unsafe, especially when there is much emaciation: thus, in a hot and dry summer, those who have travelled far, and are become thin and weak, have no need of being cooled, nor would it be safe for them to use the cold bath without first going into the warm. For we seem to be hardened by the cold bath like iron, when heated first; and if we previously warm ourselves by exercise, the effect is the same." Dr Currie's relation of an adventure of his own might almost be supposed to have been intended as a commentary on these remarks of Galen. (*Reports*, p. 120.) "On the 1st of September 1778, two students of medicine at Edinburgh set out on foot on a journey, a considerable part of which lay along one of the rivers of Scotland. They started by sun-rise, and proceeded with alacrity in the cool of the morning. At the end of eight miles, they breakfasted, rested for an hour, and then resumed their journey. The day grew warm as it advanced, and after a march of eight miles more, they arrived heated, but not fatigued, on the banks of the river above mentioned, about eleven in the forenoon. Urged by the fervor of the day, and tempted by the beauty of the stream, they stripped instantly, and threw themselves into the river. The utmost refreshment followed, and when they retired to the neighbouring inn, this was succeeded by a disposition to sleep, which they indulged. In the afternoon they proceeded, and travelling sixteen miles further at a single stretch, arrived at the inn where they were to sleep, a little after sunset. The afternoon had been warm, and they perspired profusely: but the evening was temperate, and rather cool. They had travelled for some miles slowly, and arrived at the end of their journey stiffened and wearied with their exercise. The refreshment which they had experienced in the morning from bathing induced, however, one of them to repeat the experiment, and he went perfectly cool into the same river, expecting to relax his limbs in the water, and afterwards to enjoy profound sleep. The consequences were very different. The Tweed, which was so refreshing in the morning, now felt extremely cold; and he left the water hastily. No genial glow succeeded, but a feverish chill remained for some time, with a small frequent pulse, and flying pains over the

Bathing. body. Warm liquids and frictions brought on at length considerable heat, and towards morning perspiration and sleep followed. Next day about noon they proceeded on foot, but the traveller who had bathed was extremely feeble; and though they had to perform a journey of a single stage only, as some part of it was difficult and mountainous, he was obliged to take the assistance of a carriage which overtook them on the road. It was several days before he recovered his usual vigour."

The experiments of the same judicious author, published in the *Philosophical Transactions* for 1792, afford some striking illustrations of the effects of severe cold: he employed baths at the temperature of 44° and 40°; the natural pulse of the person subjected to the experiment was about 70 in a minute, and it was generally raised to 85 or more by the preparation for immersion; but in the water it invariably sunk to about 65, becoming firm, regular, and small. The change of temperature, as measured under the tongue, was still more remarkable, and greater than could have been expected either from reasoning or from former observations; for the mercury fell, within a minute or two after immersion, from 98° or 100° to 87° or 88°; it then rose gradually, but not regularly, in a quarter of an hour, to about 96°. Upon a second exposure to the wind, it fell to about 90°, and was in one instance lowered 2° more at the first immersion in a bath of 97½°, in which the natural temperature was by degrees recovered, although not much more rapidly than it had risen during the former immersion in the very cold water; but what raised it by far the most speedily was the application of very hot water to the region of the stomach. When, however, Dr Currie himself went slowly into a bath of 36°, in a light flannel dress, and remained in it for two minutes, no observable alteration was produced in the heat of his body; and this circumstance might almost induce us to suspect that the other subjects of his experiments had incautiously allowed their mouths to be cooled by the inhalation of the cold air. Dr Marcard's experiments (p. 71) not only confirm the fact of the general retardation and diminution of the pulse by the cold bath; but they show that the retardation commonly extends to all temperatures below that of the human body, becoming, indeed, much more remarkable in the tepid bath than in a bath of the ordinary temperature of the atmosphere, which does not appear to produce the effect with equal uniformity. Thus, in a bath at 60° and at 68°, the pulse was rather accelerated than retarded: in six experiments from 70° to 80° inclusive, taking the mean of all the quantities, in order to obtain a result less liable to accidental errors, and representing all the experiments in a compendious form, the temperature was 75°, and in 20 minutes the pulse was reduced from 78 to 70: in four from 80° to 90°, the mean temperature was 87°, and the pulsations were reduced in 34 minutes from 91 to 75: in three at 90°, the mean reduction in 36 minutes was from 97 to 75: and three experiments above 90° give for a mean temperature 92°, and a reduction from 82 to 70, effected in 35 minutes. Marteau had found a slight reduction of frequency at 93°: but at 96°, according

to Dr Parr, there is commonly no observable change. *Bathing.* (Marcard, p. 63, 66.)

From these experiments Dr Marcard very justly infers, that in a great variety of cases, the warm bath affords the only direct and certain mode of lowering the pulse without inconvenience (p. 88); and we must be contented with the empirical knowledge of this fact, without attempting to explain why a temperature of 90° is more favourable for the retardation of the pulse, than a much lower temperature, at which the thermometrical heat would certainly be more rapidly reduced. Dr Steck has also made several observations on the effect of cold bathing on the pulse; but, in his experiments, the retardation was much less constantly observable than the diminution; a variation which frequently occurs when the temperature is very low.

The salutary effects of cold applications, in some cases of gout, were well known to Hippocrates, and have been more lately extolled by Homburg, Floyer, and Pietschen: Marcard (p. 256) very properly states the objections to their employment, and, notwithstanding all that Dr Kinglake has done to recommend them, they have not been adopted by prudent practitioners, except in very recent cases, and in young and unbroken constitutions. Aretseus prescribes the affusion of cold water for giddiness and headache, and it has certainly been successful in some obstinate cases of this kind (Marcard, p. 255); and has even appeared to be a powerful palliative in some descriptions of mania. In fevers, Dr Currie found its effects more permanent than those of the tepid affusion, although not always so speedy.

We have ample experience of the tonic powers of bathing in more than one of its forms; although no more than thirty or forty years ago, the great majority of practitioners in Great Britain were disposed to confine these powers within the limits of the cold, or at most of the tepid bath. But travellers in warmer countries had often informed us of the invigorating effect of a warm bath taken after fatigue; and Bruce, in particular, extolled its comforts and its salubrity, from having used it in Egypt. The opinions of Marcard on the same subject were partly made known through Beddoes: Count Rumford, in his thirteenth Essay, has exhibited, in a popular point of view, the benefits which he himself derived from taking the warm bath habitually in the middle of the day rather than at night; and Dr Alexander Buchan, in his work on sea bathing, has assisted in dissipating the remaining prejudices against its employment as a mild tonic. For feeble or enervated constitutions, and for persons who have suffered from great fatigue, it is decidedly preferable to the cold bath; but as the strength is gradually recovered, it may often increase its efficacy to lower the temperature by degrees. We may begin, for instance, with a warm bath at 96° or 98°, and lower it by degrees to 90° or a little less; and hence the transition to the open sea in the middle of a summer's day will not be too abrupt, the water being often heated to 70° or more on a coast well suited for bathing; and if the constitution appears to acquire strength under the experiment, the hour of bathing may be made

Bathing.

earlier and earlier, until the temperature is no higher than about 60°. The time of remaining in the water may also be modified according to the powers of the constitution; a single immersion being the most easily supported, and a longer continuance in the water, till the sensation of cold has subsided, calling forth the faculty of generating heat into fuller action; observing always not only how the health appears to be affected, but which mode is the most conducive to the pleasure or comfort of the individual, which will often throw some light on the operation of the remedy. In most cases it will be found, that where either warm or cold bathing agrees with the constitution, it is followed by a sense of youth, and vigour, and self complacency, which is equally agreeable and salubrious. We must also make allowances for peculiarities of constitution, which may require a deviation from the temperature usually recommended. Thus, there are some persons who have so singular a sensibility, as to feel a bath of 110° not too warm, and to be absolutely chilled by a bath of 100°: and, in such cases, it is probable that at 105° the pulse would not be materially accelerated. In other instances, the cold bath produces headache and dejection of spirits. This inconvenience is sometimes obviated by proper evacuations, which should also always be premised to bathing, where there is any appearance of visceral disease, or of congestion of any kind. The sea water will answer this purpose sufficiently well, either alone or mixed with warm milk, or with some chamomile flowers infused in it; but it has no material advantage over any other cathartic which may be preferred by the patient. It is also recommended by all authors on cold bathing to plunge in head foremost, and this precaution is highly proper where there is any apprehension of headache, but in other cases it is of little moment. If, after all, the cold bath continues to disagree, it will be generally advisable to exchange it for the warm; and after a time it may be proper to give the cold a second trial.

It is unnecessary to enter into a minute detail of the diseases in which bathing is useful as a tonic. It is, however, particularly indicated in a variety of complaints which are peculiar to females; and to weakly children, especially such as are rickety and scrofulous, sea bathing is most essentially necessary. On the other hand, cold bathing is almost universally to be avoided where there is any consumptive disease, or any inflammatory affection of any of the internal parts; an exception which is easily understood, from the natural tendency of cold to cause a congestion of blood in the vessels of those parts, in consequence of the contraction of the superficial vessels. The sudorific effect of the warm bath, followed by the refrigerant quality of the tepid, and the tonic powers of the cold, exhibit a succession of remedies nearly analogous to the mode of treatment which is usually found to be most successful in fevers of various kinds; in most of which we begin with sudorific medicines, and proceed to astringents and tonics. Hippocrates, in his book on the use of liquids, observes that gout is one of the diseases in which both hot and cold applications afford effectual relief; and the remark is equally just with respect to

Bathing.

some cases of rheumatism; but, more commonly, the best mode of using baths in rheumatism is to begin with a bath raised, during the immersion, to as high a temperature as the patient can bear, so as to act as a powerful sudorific, and to continue the course, when the pain has been relieved, at lower and lower temperatures, ending it with cold bathing in the open sea.

Notwithstanding the acknowledged utility of warm bathing in a variety of circumstances, there may possibly have been some exaggeration in the marvellous opinions which have been sometimes entertained of its utility for the prolongation of life. Galen has indeed mentioned a number of persons who had attained a great age, and who were in the habit of making daily use of the bath, which is enough to prove that such a habit cannot be extremely pernicious; and if we supposed a constitution to retain all its energies, but to have them concealed and obscured for want of proper stimuli, the warm bath might tend to remove the evil; but it is more natural to believe, that the approach of old age has a tendency to weaken the radical powers of the constitution, which cannot afford to be roused into disproportionate exertion; and to apprehend, that the temporary vivacity and activity, superinduced by any foreign agent, whether by warm bathing, or by a removal to a warmer climate, would only tend still more to exhaust the already diminished store of vitality.

The *narcotic* and *sedative*, or *specifically antispasmodic* effects of bathing are most effectually exhibited, in ordinary cases, by the warm or tepid bath, which is often employed for the relief of pain, and for the removal of any irregular or convulsive affection. Possibly also the effect of the warm bath in retarding the pulse may be partly derived from its sedative power as affecting the heart; and if we take this connexion for granted, we may infer from it, that the antispasmodic effect will be most advantageously obtained from a bath at 90°, which has been found to retard the pulse the most effectually. But where there is internal inflammation, it may be desirable to dilate the superficial vessels by a bath somewhat hotter than this, so as to relieve the internal parts from a part of the fluid which distends them, but without increasing the velocity of the circulation by too high a temperature. The cold affusion is also a powerful remedy in many cases of tetanic disease. Hippocrates (*Aph.* v. 21) has remarked, that it often creates a glow which overpowers the convulsive contraction, especially where the subject is young and athletic, the weather hot, and the disease independent of local injury; and the modern experience of Dr Wright and Dr Currie has confirmed and extended the observation. In another passage he tells us (*Aph.* v. 25), that the abundant affusion of cold water generally relieves and removes swellings and pains in the limbs as well as spasms, producing a moderate degree of torpor, which supercedes the pain; but, in fact, the relief of inflammatory affections by cold is rather to be referred to its astringent than to its sedative powers. This is, indeed, a point which has been much discussed by modern theorists; but it must be confessed, that all our

Batties.

theories are of little importance in physic, any further than as they assist us in clearly comprehending and distinctly remembering the facts, which we derive from immediate experience in the treatment of diseases.

(V. N.)

BATNEARS, or BATTIES, a people of the north part of Hindostan, inhabiting a country which extends about 200 miles in length, and 100 in breadth, and of which the capital is Batneer, situate, according to some authorities, 170, and according to others, 219 miles west-north-west of Delhi. This country comprehends part of the province of Delhi, Lahore, and Ajmeer.

The Batties present many peculiarities in manners and customs, distinguishing them from the other people of Hindostan. They seem to consist of three different races; the chief are Rajpoot Mahometans; the common people Jauts, who have adopted the same religion; and the cultivators of the soil are called Ryis, a very peaceable and inoffensive class. But in general they are characterized as shepherds; and although principally restricted to the territory whence their name is derived, various tribes of them are to be found in the Punjab; as they are also scattered over the high grounds to the east of the Indus. But great obscurity prevails in every thing regarding them.

The Batties are Mahometans, and highly venerate the memory of a certain saint, Sheik Fereed, who flourished in the fifteenth century; and it is said, that however adverse to their natural disposition, should any one, in invoking his name, claim their protection, it is never withheld. Yet their customs, in other respects, are at variance with those of the Mahometans; and particularly in the females appearing, without any reserve, unveiled in public, and in their associating promiscuously with the men, as in other countries. The wives of the Rajpoot chiefs form an exception; and it is reported among these Rajpoots, that their ancestors migrated some centuries ago from the district of Jesselmerc, and after various vicissitudes, settled in the Batneer country. Most of the inhabitants under their rule were originally Jauts, dwelling on the western bank of the river Sutledge, in the twenty-ninth degree of north latitude, and who have not been known long in the portion of the peninsula now occupied by them. Having embraced the Mahometan faith, they were invited by the ancestor of the present Rajah of the Batties to cross the river about a century ago, and settle in his country, where their posterity still reside. The Jauts constitute the lower orders of the people, and are treated with great moderation by their superiors.

The whole territory, extending as above described, is apparently under the dominion of a supreme prince or rajah, whose authority is acknowledged by inferior chiefs or rajahs; for the term rajah, in strictness, applies to none but those invested with a paramount rule. This potentate can bring 20,000 or 30,000 troops into the field, but quite undisciplined, and despising the necessary principle of subordination. His revenue chiefly arises from the plundering of his troops; for their wars are directed more to predatory purposes than to an open contest; and the rajah, instead of repress-

Batties.

ing the ravages of this immense banditti, willingly participates of the spoils. When strangers observed to him, that the soil and agriculture of his country were sufficient to enable his subjects to enjoy plenty, he replied, that the number of Rajpoots in his service is so considerable compared with the mass of the people, that, should he attempt to restrain the depredations of the latter, the subversion of his own authority might ensue, because it would be interfering with old and established customs. The rajah who made this remark was in every respect a good and humane character.

But the people over whom he rules are by no means entitled to the same repute; they are of a cruel, savage, and ferocious disposition; they entertain an utter abhorrence of the usages of civilized life; they are thieves from their earliest origin, and during their predatory incursions into the neighbouring districts, do not scruple, though unresisted, to add murder to robbery. This systematic plundering produces a revenue of above £. 120,000 *per annum* to their princes, at least that is the conjectural amount, for there are no data whereon to form exact calculations.

Many of the Batties appear to be entirely nomadic, changing their residence from place to place, as subsistence fails. Their exports are horses, camels, bullocks, buffaloes, and ghee; and they sell some surplus grain above what is necessary for their own consumption; but their traffic is very inconsiderable; and what they do carry on is with the petty merchants of Behadra, Nohur, and other towns, through the means of the disciples of the Sheik Fereed, their favourite saint. A large portion of the country is unproductive; but along the banks of the river Cuggur, from Batneer to the town of Futtahbad, the soil is uncommonly rich, and well adapted for cultivation. The inundations of this river fertilize its banks, and the subsidence of the waters leaves them to a great distance, prepared for plentiful crops of wheat, rice, and barley, amply rewarding the labours of the husbandman. It is the scarcity of water which occasions the barrenness of the ground; nevertheless, there is more raised than the inhabitants can consume. Their horses are numerous, but it is computed that they lose a fourth of them annually by the sting or bite of a winged insect; for the injured part degenerates into an incurable cancerous sore.

We are unacquainted with any river of note, excepting the Cuggur, which is lost in the sands to the westward of this district. According to the tradition of the natives, its original bed being choked up by immense quantities of earth, forced down from the mountains, its course was altered.

The chief towns of the Batties are Batneer the capital, which lies in a situation almost inaccessible to an enemy, for no water is to be procured within 12 miles, but what supplies the inhabitants; however, it was taken in 1398 by Timour, and more recently by General Thomas. Their other principal towns are Arroah, Futtahbad, Sirsa, and Ramgah, and there are many forts, which, though defenceless against the skill of European troops, are impregnable to the irregular marauders of Hindostan.

Batties. Numbers of the Batties have, of late years, emigrated from their native country, to establish themselves in the western parts of the dominions of Oude; and several families of them are to be met with in Rohilcund. They are practised travellers, and well trained to it by the laborious journies undertaken in crossing the great desert to the west of their territories. These expeditions are frequently made by large parties, for the purpose of a predatory incursion on some peaceable country more remote; and they exemplify both skill and determination in attaining their object. Camels previously laden with provisions are dispatched to different stations in the desert, which is about 180 miles in breadth, and deposited there. The most intelligent of the party, about to follow, are selected as guides, and receive the most implicit obedience from their companions during the journey, which closes at the frontier of the hostile country, or rather that to which their hostility is directed. The guides, by long experience, become expert, without compass or land-mark: they seldom fail to conduct the party to the appointed station where the provisions will be found, and thence across the remainder of the desert in safety. But should they accidentally miss the points of rendezvous, and those where their necessities shall be relieved, they are exposed to inevitable destruction, and any of their party heedlessly straying from the rest, become the victims of the accumulated evils of hunger, thirst, and fatigue. The adventurers steer their course by the sun in the day-time, and by the polar star at night; and by similar aids they are enabled to retrace the way they have travelled. Should provisions fail, a bullock is killed, roasted, and partitioned on the spot, and, after a hasty meal, the journey is resumed.

The history of the Batties has attracted the notice of few European authors. They seem to carry on frequent wars with neighbouring states, and are the most formidable enemies that oppose the Rajah of Beykaner. The latter invaded their territories some years ago, but without success, which is not surprising, considering the comparative smallness of the force which he can bring into the field, and the nature of the country. Temporary advantages were, notwithstanding, obtained over the Batties, and the Beykaner Rajah erected a fortress in Batinda, which, if not within their territory, is on its immediate confines. This contributed to overawe them for a time, and repressed their incursions into his own domains; as, independent of the garrison, he stationed a large body of cavalry in the fort, whose frequent sallies and captures of cattle annoyed the Batties so much, that they contemplated a total emigration from their own country. But a military adventurer, George Thomas, an Irishman by birth, who, endowed with singular talents and intrepidity, had founded an independent state in the north-west of India for himself, was then at war with the province of Beykaner. Having reached its frontiers, the Batties solicited his alliance, and, to induce him to espouse their cause the more readily, offered him 40,000 rupees, if he would reduce the obnoxious fort. It appears, that the Beykaner forces were now masters of Batneer, the capital, whither General Thomas, who had accepted the proposals of the Batties,

marched to dislodge them. He found a numerous garrison, and, having brought up his artillery, began to batter the place, preparatory to an assault. This, however, the enemy avoided by capitulation, and was allowed to evacuate the city with the honours of war, while the Batties were put in possession. In further prosecution of the war, several actions ensued, and various fortresses were taken; but it would appear, that one of the Battie chiefs, at variance with General Thomas, commenced hostilities against him, about the period now alluded to; and, in this new warfare with his late allies, his forces were so much reduced by repeated encounters, that, being scarcely able to stand an engagement, he fortified his camps. The Batties, after frequent attacks, withdrew their troops by night, whereon General Thomas took and burnt Futtahbad, and other places, and might have occupied the whole country; but a neighbouring chief, having concluded an alliance with the Batties and sent 1000 cavalry to their aid, General Thomas retreated to Jyjur, a town within his own territory, in order to relieve his people from the fatigues and diseases of the preceding campaign. (s.)

BAUMÉ (ANTHONY), a druggist in Paris, distinguished by his knowledge of chemistry, and by his practical application of that knowledge, was born at Senlis in 1728. He was the son of an innkeeper, and was put apprentice to the eminent chemist Geoffroy. He had not received a regular school education, a defect which occasioned him many difficulties in prosecuting his scientific researches, which he nevertheless did with much ardour. In 1752, he was admitted a member of the College of Pharmacy. Soon after he was appointed professor of chemistry at that establishment, and in his lectures he displayed the excellent arrangement which is seen in his published works. He carried to a great extent his commercial establishment in Paris for the preparation of drugs for medicine and the arts, such as the acetate of lead, the muriate of tin, mercurial salts, and antimonial mixtures. At the same time, he published papers on the crystallization of salts, on the phenomena of congelation, on those of fermentation, on the combinations and preparations of sulphur, opium, mercury, boracic acid, platina, and Peruvian bark, on the metallic oxides, the acetates of the alkalis, on emetic tartar, on vegetable fecula, and on vegetable extracts. In consequence of these scientific works, Baumé was elected a member of the Academy of Sciences. He wrote a great many articles in the *Dictionnaire des Arts et Métiers*, and had previously published several technological papers, namely on dyeing, on the gilding of clock-work, on a method for extinguishing fires, on the mode of keeping corn, on buildings of plaster, on soap-making, on clay, and on the nature of soils fitted for agriculture. He made numerous experiments along with Macquer, for the purpose of fabricating in France a porcelain equal to the Japanese. He established the first manufactory of sal-ammoniac in France, a substance which before that was obtained from Egypt. He was the first who devised and set on foot a process for bleaching raw silk. Having acquired a competency by the success of these different undertakings, he retired from trade, and devoted his

Batties
||
Baumé.

Bonné
Bavaria.

time to the application of chemistry to the arts. He improved the process for dyeing scarlet at the manufactory of the Gobelins, and he published a cheap process for purifying saltpetre. He bestowed much time in forming an aréometer intended for general use; and published a process for obtaining a mild fecula from the horse-chestnut. By the revolution he lost his fortune, but was not thereby disheartened: this calamity led him to resume his trade. He was chosen a correspondent of the Institute in 1796. He died in 1804, at the age of 76. He was temperate, regular in his habits, and active. Many of his papers are published in the *Mémoires de l'Académie des Sciences*. Of his separate publications, the following may be mentioned here: *Dissertation sur l'Ether*, in 12mo. *Plan d'un cours de Chimie Experimentale*, 1757, in 12mo. *Opuscules de Chimie*, 1798, in 8vo. *Elements de Pharmacie Theorique et Pratique*, 2 vols. 8vo. *Chimie Experimentale et Raisonnée*, 3 vols. in 8vo, 1773. This last is antiquated, on account of the many improvements which have been made in the science of chemistry since its publication; but his *Elements of Pharmacy* are still useful, as a good dispensary, written with method and clearness: the processes are well described, and the formulæ properly discussed. He did not adopt the Lavoisierian Nomenclature.

Recent
History.

(x.)
BAVARIA. This country has undergone several very remarkable changes within the last forty years. The first of these political agitations, in point of time, and the greatest, perhaps, in point of general interest (for, in those days, the European public were not accustomed to the making and unmaking of governments), was the disputed succession in the year 1778. It was occasioned by the extinction of the reigning branch, by the death of the Elector, on 31st December 1777. The right of succession, on the part of the collateral heir (the Palatine of the Rhine), admitted of no doubt; but various fiefs, obtained at successive intervals by Bavaria, were of a nature to be considered in the light of Imperial property, on the failure of the direct line. This, however, was but a small part of the expected change—the House of Austria, having long cast an eager eye on a province which lay so conveniently for annexation, and which had so often, by the influence of France, proved a thorn in its side, was impatient to avail itself of this opportunity of obtaining possession of Bavaria. Little opposition was to be expected from France, the young king (Louis XVI.) being married to a sister of the Emperor Joseph; but a very different conduct was anticipated from Frederick II. This warlike sovereign, though now approaching to his 70th year, came forward in support of the independence of Bavaria with all his characteristic decision; and though unsupported by the heir of the late Elector, found means, by dint of military and diplomatic exertion, to induce the cabinet of Vienna to desist from the chief part of its ambitious pretensions. Had England been so situated as to come forward with the appearance of efficient co-operation, the matter would have been speedily brought to issue; but we were then embroiled with our American colonies, so that the object of the Prussian

Bavaria.

court was not attained without formidable armaments, and a repetition of manœuvres indicative of hostilities on a large scale. Fortunately, however, the remembrance of the seven years' war, the recollection of the firm stand made by Prussia, and the disposition to resistance evinced by the smaller courts of Germany, had the effect of producing an adjustment without bloodshed. The particulars of this interesting episode in German history, are given at considerable length in a pamphlet lately published, under the title of *Mémoire Historique de la Négociation en 1778, au sujet de la Succession de la Bavière*.

From this time forward, Bavaria remained in profound peace until the French Revolution roused Germany to arms. The Elector, although pacifically disposed, felt it necessary to join a cause embraced by Austria and England, and continued to let his contingent fight along with the Imperialists, until the French found the means of making their way into the interior of the empire. His first departure from the alliance took place in 1796 (August), when Moreau advanced with a powerful army to his capital, and concluded a treaty for a cessation of hostilities, at a moment when the French were expected to invade the Austrian states in three different directions. This time, however, the project of invasion failed, the armies being too much divided, and one of the generals (Jourdan) being ill qualified to meet a moment of emergency. The peace of Campo Formio was concluded next year under circumstances that began to favour the influence of France in Germany, and particularly in Bavaria. This peace lasted hardly two years; and, in the second war, Jourdan advanced once more (March 1799) to experience new defeats at the hand of the Austrians. This army bore the high-sounding name of *Armée de l'Execution de l'Empire*, but its composition bore many marks of the corrupting influence of an interval of peace and bad government. Bavaria remained free from the presence of contending armies for somewhat more than a twelvemonth, until Moreau advanced at the head of a much more powerful and better appointed force. His operations were crowned by the decisive victory of Hohenlinden, and the influence of France over the empire too strongly confirmed by the peace of Luneville.

It is from the date of that treaty (1801) that we are to look for the direct interference of Bonaparte in the affairs of the interior of the empire, where the disunion of Austria and Prussia paralyzed every wish to assert the independence of the Germanic name. That wish, however, was not strongly felt in Bavaria, where Bonaparte's character was not understood, and where the predominant feeling was a dread of Austria. An alliance was accordingly contracted between Bavaria and France; and when, in the summer of 1805, there remained no farther doubt of the hostile movements of Austria and Russia, Bonaparte thought proper to delay his notice of war until the Imperialists had passed the frontiers of his new ally. The consequence of the disastrous campaign that ensued was the aggrandizement of Bavaria by the cession of various provinces, particularly Tyrol, and the elevation in 1806 of the Elector to the title of King.

Bavaria. The subsequent resignation of the rank of Emperor of Germany by Francis II. the formation of the Confederation of the Rhine, but, above all, the overthrow of Prussia, rendered the power of France paramount throughout the empire, and enabled her, in 1809, to find, even in a German force, the means of resisting the efforts of Austria. The connection of Bavaria and France, now farther confirmed by the marriage of Bonaparte's step-son to a princess of the reigning family, seemed to rest on an immovable basis, when the intoxication of success produced at last the memorable march to Moscow, and made the possession of unparalleled power the cause and instrument of its own overthrow.

The Bavarian force engaged in the Russian expedition perished chiefly in the latter part of the retreat, between the Berezina and the Niemen. The horror excited by so melancholy an event, and the hatred inspired by Bonaparte's tyranny for some years back, created a general desire in the Bavarians to make common cause with their countrymen in the north, and vindicate the independence of Germany. The public, however, both there and elsewhere, imagined that the court would not go along with the people; and, after the rupture of the armistice in August 1813, Bavaria stood ostensibly on the side of France. Two months elapsed, before it was discovered that this attitude formed part of the plan concerted with Austria, and discovered to the world only by the sudden march of the Bavarians to interrupt Bonaparte's retreat at Hanau. General Wrede commanded on that occasion with great spirit, and caused a severe loss to the French; but found it impracticable to arrest the progress of a mass which pushed on in close order, regardless of the havoc made on its flanks and extremities.

Bavaria now followed, without interruption, the line of policy concerted with Austria, and was not supposed to waver for a moment on the temporary resumption of power by Bonaparte when he landed from Elba. Her unexpected abandonment of him in 1813, is to be attributed to a guarantee from Russia and Austria that she would be maintained in the possession of her actual acquisitions, subject, however, to partial changes, of which the principal was the restitution of Tyrol. That country, proverbially poor, was attached to Austria with all the ardour natural to a retired and simple population. Its relinquishment was, therefore, a slight sacrifice for Bavaria, when compared with the fate that would have awaited her had she ventured, like Saxony, to resist the allies. The proceedings of the Vienna Congress, as well as the subsequent treaties, placed Bavaria on the footing of a power of consequence, confirming the title of the King, granting him a share of the contribution-money paid by France, and stipulating the support of a division of Bavarians, along with the other allies, at the expence of that country.

The military establishment of Bavaria has lately been raised to nearly 60,000 men; in peace, it will probably be somewhat below the half. The population, including the late acquisitions, is understood to exceed 3,000,000; the revenue about L.1,500,000 Sterling. Considerable progress has been made during the last half century in redeeming the reproach

of ignorance, so long cast on the inhabitants of this, in common with the other southern provinces of Germany; for it must be confessed, that all that we had occasion to lament in regard to the backwardness of education and knowledge in our account of Austria, is applicable to Bavaria. The misfortune of both countries has been a bigoted and ignorant priesthood, who, not content with absorbing in their own hands a very valuable portion of the lands of the country, have all along insisted on the expulsion of the Protestants, and on the observance of the endless holidays and absurd usages which impede the progress of industry among their followers. Hence, a general habit of indolence, and miserable backwardness in agriculture; and, in point of learning, a complete contrast to the northern part of Germany. It would be wrong, however, to carry this unpleasant picture so far as to represent the present generation as worse than their ancestors, or the population as in a state of diminution. On the contrary, Munich hopes ere long to rank among the literary cities of Germany; but ages will be required to bring the population on a level with their northern neighbours.

Bavaria, like Austria and the rest of Germany, has, all along, had the semblance of a representative government, composed of prelates, noblesse, and deputies from the towns. Munich is their place of assemblage; but they have met very seldom for a long time past. That city contains a population of between 40,000 and 50,000 inhabitants, and is one of the handsomest towns in Germany.

As to soil, Bavaria is mountainous and woody towards the south; the ground rising in the direction of the Alps, and containing a number of lakes and marshes, with little that has as yet been brought under tillage. To the northward are plains, extensive and rich, until we reach the Palatinate, which is, in great part, mountainous and woody. The word Palatinate being ambiguous, it may be well to observe that the Palatinate, properly called Bavarian, lies to the north of the Danube, and has Amberg for its capital. But the Rhenish Palatinate belonged likewise, until recent exchanges, to the dominions of this house, the late Elector of Bavaria having been originally a member of the Imperial Diet, in the capacity of Elector Palatine, and having, by his succession to the government of Bavaria, combined the possessions of the two houses. His chief error was, like that of his neighbour, the Emperor Joseph, a desire to introduce improvements without making sufficient allowance for the ignorance of his subjects. He abolished the monastic orders in parts of his dominions, which were by no means ripe for such a change. A great deal has been said about the masonic and other secret societies formed in this country, at the time of the French Revolution, and combining, as was pretended, their efforts with similar societies in Prussia, for the purpose of shaking the established government. These rumours, we are inclined to think, had but slender foundation, there being very little in the condition of Bavaria to afford a promise of success to so strange a project. The present King succeeded to the Electorate in 1799; he was formerly Duke of Deuxponts, and cousin of the preceding Elector. (pp.)

Bayen.

BAYEN (PETER), a celebrated chemist, member of the Institute of France, was born in 1725, at Chalons sur Marne. He showed a great inclination to study, and was sent by his parents to school at Troyes, where he went through a course of classical education with success.

The bent of his disposition was to physical science. He went to Paris in 1749, and became the pupil and friend of an eminent druggist. In this situation, he acquired a complete knowledge of the profession; and before the age of thirty, he was appointed chief apothecary to the French army in Germany, in the seven years' war, a situation which he filled with industry, intelligence, and integrity.

After the conclusion of peace, he returned to Paris. The French government had employed Rouelle to name chemists for the purpose of analyzing the mineral waters which are found in different parts of France, and had allotted funds for this purpose. One of the chemists named was Bayen, and he employed himself ardently in these analyses for several years. His analysis of the waters of Barége and of Bagnères de Luchon are published; and besides the detail of accurate and well-contrived chemical processes, they contain matter interesting to the medical man, to the naturalist, and even to the general reader. He resided at the above-named baths in the Pyrenées, whilst he was employed in analyzing the waters. The project of the French government was not carried farther than the analysis of these waters, so that the public employment of Bayen now ceased.

He returned to Paris, and made the analysis of different minerals which he had collected, chiefly during his residence in the Alpine region of the Pyrenées; amongst them is the marble of Campan, of which there are two varieties, the red and the green. These are brought from that country to Paris, where they make a distinguished figure in ornamental architecture, as may be seen in the columns of the palace of Great Trianon, in the interior of the church of St Sulpice, and in other great buildings. These analyses are published in the *Mémoires présentés à l'Académie par divers Savans*, commonly called *Mémoires des Savans Etrangers*.

He made most accurate experiments on the oxides of mercury, to show that oxidation arises from the absorption of a portion of the atmospheric air, and that the existence of the phlogiston of Stahl could not be proved. Lavoisier was present when the account of these experiments was read, and was employed at the same time in examining the metallic oxides, and it was Lavoisier that brought the subject into a clearer light, and demonstrated the nature of oxygen, and the composition of the atmosphere.

Bayen published an analysis of tin and pewter. In consequence of the writings of some German chemists, fears had arisen amongst the public, that the use of these metals in culinary vessels was pernicious. Bayen showed that these fears were without any ground, if the pewter be of the legal standard, and be not fraudulently mixed with too great a portion of lead.

His mode of analyzing minerals required a long time; he exposed the mineral, without being redu-

Bayen
||
Bazeegurs.

ced to powder, to the action of sulphuric acid at the temperature of the atmosphere; after this action had continued for a length of time, he got by lixiviation the sulphates formed by the combination of the acid, with the different component elements of the stone. He did not make use of the trituration of the stone to an impalpable powder, nor its fusion with caustic potash, which facilitate the subsequent action of acids, and which are used with so much advantage in the processes of modern chemists. The account he has published of his analysis will, nevertheless, be instructive to the chemical student, although the excellent and expeditious methods of Klaproth and Vauquelin are those that should be followed in practice.

He enjoyed good health till sixty, and died at the age of seventy-six, in the year 1801. He was a man of sound judgment, of strict integrity, and acquainted with several other branches of knowledge besides that which he particularly cultivated. There is a collection of his works, entitled, *Opuscules Chimiques*, 1798, 2 vols. 8vo. (Y.)

BAZEEGURS, a tribe of Indians, inhabiting different parts of the peninsula of Hindostan. The appearance and manners of mankind are so much diversified in the various countries where they dwell, that animated controversies have been excited, whether all have had a common origin; or whether they have sprung from Protoplasts, whose conformation, at the beginning of the world, was dissimilar. Some maintain, that, in consequence of the changes produced by situation, climate, and circumstances, the present generations may possibly exhibit figures and proportions altogether different from those that distinguished their ancestors thousands of years ago; while others hold that no such differences could appear, unless they had actually formed a part of the original conformation of a race. The partisans of either theory have appealed to that uniformity of features and customs known to be continued among tribes, who preserve their own descent pure and unmixed with others, of which the Jews constitute a striking example; and a case something similar, though not equally prominent, is that of the Bazeegurs. This class of people is recognised by several appellations, as Bazeegurs, Panchperree, Kunjura, or Nuts; they follow a mode of life, distinguishing them from the Hindoos, among whom they dwell; they also abstain from intermixing their families with them, and from any intercourse by which they can be united. The name Bazeegur is said to signify a juggler; some etymologists find a probable derivation of conjuror from Kunjura, which might certainly find a corroboration from the similarity of professions. In India, they are dispersed throughout the whole country, partly in wandering tribes, partly adhering to fixed residences, but the greater proportion lead a nomadic life.

The Bazeegurs are divided into seven casts, Charee, Athbhyeea, Bynsa, Purbuttee, Kalkoor, Dorkinee, and Gurgwar; but are the same people, intermarrying as such, and avoiding alliances with other tribes. According to their own traditions, they descend from four brothers, who, finding it difficult to provide for their numerous followers, resolved to separate, and

History.

Bazeegurs to direct their course respectively to each quarter of the world; in consequence of which, one of them, named Sa, arrived in Bengal from Gazeepour or Allahabad. He took up his abode at Hoogly, and having governed his tribe peaceably during many years, died at Uncourpoo, whither his posterity still repair to offer up their prayers to his manes. Sa left three sons who succeeded each other, and the succession having afterwards regularly passed through several generations, at length devolved to Munbhungee, about fifteen or twenty years ago. At the same time, some of the casts considered a woman, called Toota as the chief of the whole; but the power ascribed to the chief seems merely nominal, scarcely amounting to restraint, and not at all to coercion. Munbhungee only resisted the entrance of any of the people, acknowledging the superiority of Toota, to seek a livelihood in the territory occupied by his own sect; and the latter were under the same prohibition with respect to the places frequented by her and her dependents. Besides those who are united into sets or casts, there are individuals who wander about endeavouring to gain a precarious livelihood.

It is not evident, although the Bazeegurs are certainly distinguished by their manners and customs from the natives of Hindostan, that their features discriminate them as a separate race. Some of their women are reputed to be very beautiful, and are thence sought after in those temporary alliances common in the East. The manners of the Panchperee are somewhat different from those of the Bazeegurs; and some of the sects are more civilized than others. It has already been observed, that they are not in the exclusive occupation of any district in particular, but their villages or respective quarters are found in the same places as those of the Hindoos or British settlers. The Panchperee form neat little encampments in the upper provinces; their huts are small and regular, and each is surrounded by a small inclosure or court-yard, generally disposed in such a manner that the whole hamlet, formed of portable matting, obtains a kind of circumscription by means of them.

Religion.

The Bazeegurs, more especially distinguished by that name, are the most civilized of the whole; they are Mahometans in food, apparel, and religion. The Panchperee profess no system of faith in preference, adopting that of any village indifferently, whither their wanderings may guide them. Some traverse the country as Mahometan Fakeers, and live on the ill directed bounty of devotees; and a particular association among them, of bad repute or abject superstition, has been accused of sacrificing human victims. Notwithstanding their ignorance of the established religions, they seem to venerate a female deity, Kali, probably the sanguinary goddess of the Hindoos, and may perhaps in this way seek to purchase her protection. The Bazeegurs are circumcised, and have priests to officiate at their marriages and funerals, but their knowledge of the prophet Mahomet is very imperfect, for they can give little account of him, except that he was a saint. They seem to acknowledge an omnipotent being, and con-

ceive that all nature is animated by one universal spirit, which the soul, as being part of it, will rejoin after death. At the birth of their children, some Bramin, supposed an adept in astrology, is called in to aid them in choosing a propitious name.

Among the Panchperee, the marriage ceremony **Manners.** is commenced by the bridegroom repairing to the hut of his elect, and calling aloud for her to be delivered to him. A near relation, guarding the door, resists his entrance, and rudely pushes him away, while he is the object of taunts and jocularities; but when his patience is supposed to have been sufficiently put to the test, the bride is brought out. Both receive an exhortation from the priest to practise mutual kindness, and the bridegroom, marking the bride's face with ochre, declares her his wedded wife, and she, on her part, does the same in return. The little fingers of their hands are now joined, and a scene of merriment, from which the bride alone is exempted, commences. But this consists chiefly in the progress to intoxication, for all these people are addicted to the most immoderate use of spirits; and after copious libations, a cavalcade, formed of the two parties, whose little fingers are again joined, their parents and friends, departs for the hut of the bridegroom. Before the door there are some enigmatical ceremonies performed; the mother of the bridegroom advances with a sieve containing rice, paint, and grass, with which the foreheads of the couple are touched, after being waved around them; and the bride is led into the house, before which there stands a small fresh branch of the mangoe tree in an earthen pot of water. The meaning of these ceremonies is not well understood; but it is to be observed, that the origin of most of the customs of the modern races of mankind, are lost in the darkness of antiquity. Some of the peasantry in Britain have various ceremonies both at marriages and funerals,—such as breaking a cake above the head of the bride, or strewing flowers on the bier of one deceased, which have descended from remote ages, and arose from sources at this day unknown. When these ceremonies are completed among the Bazeegurs, a new scene of mirth is resumed; and towards evening, for the whole day from the breaking of dawn is thus occupied, the bride is conducted to her own hut, when those who are able retire; but the majority, and in general the bridegroom among them, pass the night in a state of insensibility on the neighbouring plain.

From the earliest period they are accustomed to intoxicating draughts; even infants of five or six months old are supplied with spirits, though their mothers suckle them during five or six years; and it is not uncommon to observe several children of different ages hanging on their mother, and struggling to extract their scanty portion of nourishment, which is gradually diminished by her own insatiable propensities to the same beverage. Many of the sects are very indiscriminate in food; scarce any thing is rejected; dead horses, jackals, and bullocks, are alike acceptable; and it has been suspected that they can even enjoy a repast of human flesh. However, this fact is not authenticated, and if analogical reasoning may be admitted here, we should be inclined to

Bazeegurs. deny it, because there is no proof that any tribe, however savage, is addicted to anthropophagy, if dwelling among a more civilized people.

Occupations. The chief occupation of the Bazeegurs seems to consist in feats of address and agility to amuse the public, in which both males and females are equally skilful. The former are extremely athletic, and the women are taught dancing, which, instead of the graceful motions seen in the north, there consists principally in a display of lascivious gestures. Most, if not all, the men are jugglers, tumblers, and actors, in which they are very adroit. The people of each set, or dramatis personæ, are hired out by a sirdar, or manager of a company, for a definite period, generally one year, after which they are at liberty to join any other party. But no person can establish a set of actors without permission from the Nardar Boutah, a chief of the Bazeegurs, who receives a proportion of the profits, and a tribute or tax from each female, somewhat analogous to what was called milk-money, a revenue levied by the Holy See from licences to prostitutes. On the return of a party from an excursion, this money is paid to the Nardar Boutah, who convenes his people, and they continue feasting until the whole is expended. Should any of the managers be suspected of giving an unfair account of his profits, a court is assembled, where the accused must undergo the ordeal of applying his tongue to a piece of red-hot iron. It thus appears that these tribes have a kind of civil government among themselves; that each of five sets, at Calcutta at least, has a sirdar or ruler, and that the whole are subject to the Nardar Boutah. These sirdars and the chief apparently constitute a court for the trial of infringement of their regulations, which may be followed by punishment. Thus if, on application of the red-hot iron, the suspected manager be burnt, he is declared guilty of a fraud, which is expiated by a fine, and, if it be an aggravated offence, by the additional punishment of having his nose rubbed on the ground. The same penalty is attached to disclosures to strangers of matters which it is the interest of the tribe to conceal. The fine is generally converted to liquor; but should the offender be either unable or unwilling to discharge it immediately, he is banished from all society; or he is universally execrated, and even his wife and children avoid him. He soon finds compliance indispensable, and although the Bazeegurs pique themselves on their honesty, it is conjectured that on such occasions they do not entertain many scruples in acquiring what is so essential to avert the indignation of their fellows. The mulct being paid, is converted to the general behoof, and affords a new opportunity for gratifying the strong propensities implanted in these people for ardent liquors. All differences among this set are the subject of reference either to a *puncheat* or a general assembly; but, before commencing the business, both plaintiff and defendant must provide a quantity of spirits proportioned to the importance of the case. The party non-suited ultimately bears the whole expence, and the assembly is regaled with the beverage produced by the litigants.

Bazeegurs. Some of the Bazeegurs are owners of land, which they entertain a great desire to obtain, but they are never cultivators. They are collected, as already observed, into various associations in different parts of India. The dancing girls, however, have no regular and settled habitations; they dwell merely in temporary huts, erected near the place of their exhibitions. The duration of their lives is supposed to be much abridged by the course of life which they lead, particularly from the violent exercises practised from early youth, and habitual indulgence in intoxicating draughts. Both males and females undergo such a regular progress of debauchery, that few live beyond forty, and many do not attain their thirtieth year. But, from the pursuits of the females being productive to their parents, their marriages are deferred to a later period than is usual in India. There prostitution is free from that odium and contempt which it incurs in Europe, and those females who are considered so unfortunate and depraved by us, are under the special protection of the laws. The female Bazeegurs who are taught singing and dancing only, are under no greater personal restraint than the common dancing girls of Hindostan; but the chastity of those whose particular department is tumbling, is strictly enjoined until their place be supplied by others more youthful. When this substitution comes, they join the companies of dancers alone; and the men, though quite aware of their incontinence, do not scruple to select wives from among them. But, after marriage, a total change of conduct is expected, and it is said that such expectations are commonly realized. Nevertheless, among the Panchperee, the fidelity of those employed in different vocations in the towns becomes suspected, if they have not returned to their homes when the cry of the jackal is heard, and their husbands are by no means disposed to overlook the offence. It does not appear, however, that they have either the power or the inclination of the Hindoos, who sometimes, in such cases, decoy their own daughters to a lonely place for the purpose of perpetrating a barbarous murder on them, as the punishment of their indiscretion. The Bazeegur parents and husbands are content with slighter expiations; but if the paramour be not of their own particular cast, the incontinence of the female is judged a much more grievous fault.

The females now alluded to are those who do not attend the juggling exhibitions of the men, or their feats of activity; they practise phisic, cupping, and perform a kind of tawtowing on the skin of the Hindoos of their own sex, called Godna. As the men, besides their usual occupations, collect medicinal herbs, and a certain bud, the latter is dried, and the former prepared by their wives as curatives, especially of the complaints of their own sex: thus they find employment in the towns, in such vocations, or by the sale of trinkets, though both afford but a precarious subsistence. Some tribes also exhibit wild beasts to the vulgar, or offer mats fabricated by themselves for sale. Before the establishment of the British government in Bengal, the Bazeegurs were subject to the arbitrary exactions of a tax-gatherer whom they greatly dreaded, and the

Bazegurs apprehension of the renewal of that officer's powers has proved a considerable impediment to investigating their manners and customs.

Beattie.

A general coincidence in the mode of life, the vocations, manners, and language of all the different sects of these people, determine them as belonging to the same race. The distinctions seen among them are too trivial to admit of their being considered of separate and independent origin. They are different from all the other tribes dispersed throughout Hindostan; and have two dialects also peculiar to themselves, the one most probably a jargon, which is spoken only among the public performers; the other, in common use, among the whole. The Bazegurs are supposed to present many features analogous to the Gipsies scattered over Europe and Asia, where they subsist as a distinct race from all the other inhabitants of the countries frequented by them. Both the Bazegurs and Gipsies have a chief or king; each has a peculiar language, bearing some reciprocal analogy, and different from that of the people among whom they reside, and this analogy is so decided, that it is difficult to deny, that with both it has had a common origin. In India, and in Europe, they are equally an itinerant race; their pursuits, in so far as modified by the manners of countries distant from each other, are alike; for the discrepancies they exhibit, may reasonably be ascribed to an insensible acquisition of the habits of those near whom the various tribes of mankind dwell. They are equally indifferent as to the quality of the food serving for their subsistence; and equally ignorant of systematic religious principles. All preserve the strictest adherence to their own sect, and sedulously abstain from intermixtures or intermarriages with those of every nation; and where infringements of these rules are seen, they are to be ascribed more to necessity than inclination. Another resemblance, which has probably been lost in the lapse of time, is supposed to consist in the three-stringed viol, introduced into Europe by the jugglers of the thirteenth century, which is exactly similar to the instrument now used in Hindostan. Separate and disjointed, these analogies may not carry conviction of the identity of the European Gipsies with the Indian Bazegurs, but, on uniting and combining the whole, it does not seem unlikely, that if Asia is their original country, or if they have found their way from Egypt to India, they may also have emigrated farther at a period of remote antiquity, and reached the boundaries of Europe. (s.)

BEATTIE (JAMES, LL.D.), a distinguished moralist and poet, was born on the 25th October 1735, at Laurencekirk, then an obscure hamlet, in the county of Kincardine in Scotland; near which place his father rented a small farm. He received his early education at the common school of the parish; of which it is recorded, that Ruddiman had been teacher in it about forty years before. His acquirements are said to have been interrupted at this time by want of books; a difficulty which has excited commiseration in more instances than that of Beattie, but which is so little able to control natural genius, that it seems almost an incitement to its exertions; as "all impediments in fancy's

course are motives to more fancy." He first became acquainted with English versification through Ogilby's translation of Virgil.

Beattie.

By their father's death he had been thrown, while yet of tender age, on the care of his elder brother, David Beattie; who, observing his natural endowments, afforded him, notwithstanding his own limited means, every aid in his power towards a liberal education; and in the year 1749, placed him at Marischal College, Aberdeen; where he soon afterwards obtained a hursary, or exhibition. Here he had the advantage of pursuing his studies under Dr Thomas Blackwell, author of the *Life of Homer*, Dr Gerard, and other eminent men. In addition to his academical course, he began at this time to instruct himself in the Italian language; and appears to have had a strong predilection for Metastasio.

In 1753, he was appointed schoolmaster of Fordun, a small village at the foot of the Grampian mountains, where he likewise performed the duty of precentor, or parish clerk, usually attached to that office in Scotland. Here he indulged the propensities of the youthful poet, and frequently wandered during a whole night in the fields, chewing "the food of sweet and bitter fancy;" and it was from a height in this neighbourhood that his eye first caught a glimpse of the ocean. From the scenery of this secluded spot, he appears to have derived, as might be expected, many of those images which he afterwards transferred into his poetical compositions; and, certainly, no exertion of the inventive powers can furnish representations equal to these immediate copies from nature. Such is that picture in the small poem, which he calls *Retirement*.

"Thy shades, thy silence, now be mine,
Thy charms my only theme;
My haunt the hollow cliff, whose pine
Waves o'er the gloomy stream;
Whence the scared owl on pliginous gray
Breaks from the rustling boughs,
And down the lone vale sails away
To more profound repose."

Such also, among many others in the *Minstrel*, are those beautiful pictures contained in the 20th and 21st stanzas of the first canto.

In this recluse place, Beattie was discovered and noticed by Mr Garden, afterwards Lord Gardentown, then Sheriff of the county, and by Lord Monbodo. In 1757, he became a candidate for the situation of usher in the Grammar-school of Aberdeen. He was at this time foiled in the competition; but, next year, on occasion of a new vacancy, he was requested to accept the office. Lastly, he was removed, in 1760, to the Professorship of Moral Philosophy and Logic in the Marischal College. Here he passed the remainder of his life, occupied in the zealous discharge of his professional duties, and in literary pursuits. Here, too, he possessed all the advantages of a congenial society, in the company of Dr George Campbell, Dr Reid, Dr Gerard, and other men of genius and learning, who then adorned the university of Aberdeen.

His first publication was a small collection, entitled

Beattie. *Original Poems and Translations*, which was printed in 1760 or 1761. Of many of the pieces contained in this little volume he was afterwards ashamed; and not only omitted them in the subsequent selections which he published, but endeavoured, as far as possible, to obliterate all traces and recollection of them. Of these lesser pieces, *The Hermit* is best known; and, though it cannot be considered as a finished composition, is full of pathos and beauty. In *The Battle of the Pigmies and Cranes*, translated from the Latin of Addison, he has displayed a greater command of terse and happy expression than in most of his original pieces.

Mr Beattie was married, in 1767, to Miss Mary Dun, daughter of Dr James Dun, rector of the Grammar-school at Aberdeen. This connection, at first every way auspicious for his happiness, proved, in the sequel, a source of the deepest distress. For, in the course of a few years, Mrs Beattie, whose mother had laboured under a similar malady, showed unequivocal symptoms of mental disorder, which terminated in a state of confirmed insanity.

In the year 1770, Mr Beattie published his *Essay on the Nature and Immutability of Truth, in opposition to Sophistry and Scepticism*. His design was, to "prove the universality and immutability of moral sentiment;" and his motives for the undertaking are sufficiently evident from the title which he has prefixed to the book. He appears to have been particularly encouraged to the prosecution of this task by the opinions of Dr John Gregory and Dr Blacklock. A general outline of the work, which appeared in most of the journals previous to its publication, was prepared by the latter. His original intention, as expressed by himself in one of his letters, was, "first, to have considered the permanency of truth in general;" and, secondly, to have applied the principles which he should have established "to the illustration of certain truths of morality and religion, to which the reasonings of Helvetius, of Mr Hume in his *Essays*, and of some other modern philosophers, seemed unfavourable." Of this plan, the former part only was completed. It is well known that, in the execution of it, the author did not spare the opinions of those whom he considered as the enemies of religious and moral truth; and particularly treated the writings of Mr Hume without reserve or qualification. The friends of the latter took up arms in return, representing the *Essay* as a piece of personal and unprovoked hostility; and, some time after, the opinions which it contained were canvassed in a more public manner, and with much severity, in an *Examination* by Dr Priestley. These attacks, or retaliations, were met by Beattie with the same firmness which he had displayed in the original publication of his sentiments; nor would he ever consent to abate either the plainness or spirit with which he had expressed them.

In proportion to the censure which this publication called forth from a certain number of persons, was its favourable reception with a different class. It was the means of gaining for its author the unsolicited good offices of George Lord Lyttleton, Dr Johnson, Hurd Bishop of Worcester, Percy Bishop of Dromore, and many others. From the great suc-

cess of the work, a second edition of it was called for in 1771. Mr Beattie visited London in the same year, and again in 1778. On the last of these occasions; he received some flattering marks of public notice and distinction. He had the honour of being admitted to a private and long interview with their Majesties; received, from the University of Oxford, an honorary degree of Doctor of Laws, at the same time with Sir Joshua Reynolds; and was afterwards requested by the latter to sit for his portrait. The reputation of his *Essay*, and still more, perhaps, the motives and general character of the author, likewise procured for him, about this time, a yearly pension of L.200 from the Crown.

In the course of the same year, 1778, he published the first part of his *Minstrel, or the Progress of Genius*; to which he added a second part in 1774. His object, as described by himself, was "to trace the progress of a poetical genius, born in a rude age, from the first dawning of fancy and reason, till that period at which he may be supposed capable of appearing in the world as a Minstrel; that is, as an itinerant poet and musician; a character which, according to the notion of our forefathers, was not only respectable, but sacred." It appears from his letters, that he little anticipated the favourable reception which this poem obtained from the public; a doubt which was probably founded on the want of incident and variety of character, in the composition. Its merit, however, was quickly acknowledged; and by it the author's reputation, as a poet and a man of genius, was raised to its height.

On occasion of a vacancy which occurred soon after in the chair of Natural and Experimental Philosophy at Edinburgh, it was proposed that Dr Beattie should become a candidate; to which step he was strongly urged by some of his friends, particularly Lord Hailes. And, about the same period, he received various offers of preferment in the English church. These plans of promotion, however, he successively declined, considering the situation which he held as best adapted to his abilities, and affording him the greatest opportunities of usefulness. His reluctance to accept a chair in the university of Edinburgh arose partly, indeed, from the remaining effect of those heats which controversial metaphysics had produced. "I am so great a lover of peace," he says in a letter to one of his friends on this occasion, "and so willing to think well of my neighbours, that I do not wish to be connected with one person who dislikes me."

Between the years 1780 and 1798, he published his *Elements of Moral Science*, and various other works, moral and critical, which are well known, and deservedly popular. He enjoyed the acquaintance and friendship of many distinguished characters, in different classes of society. Among his literary correspondents in England were Bishop Porteus, Mrs Montague, Scott the poet of Amwell, and Mr Gray. He was entrusted by the latter, in 1768, with superintending an edition of his poems, printed by Foulis.

During the latter period of his life, Dr Beattie experienced a new train of domestic calamities, which, added to the unfortunate situation of Mrs Beattie,

Beattie. gradually undermined his health, and impaired his intellectual powers. The first and severest of these trials was the loss of his eldest son, James Hay Beattie, who died in 1790; in whose society he had found one of his greatest enjoyments, and who had already been associated with him in the Professorship of Moral Philosophy, at the early age of 19.* Some years after, his only remaining son, Montague Beattie, likewise died, after a short illness. This event he intimated to one of his friends, by a letter written on the same day, in the terms of calm and unaffected resignation. But his mind had been violently shaken, even before this blow; and, when he looked on the dead body of his son for the last time, he gave way to the scene, and exclaimed, "Now I have done with this world." Its first effect was the loss of memory respecting his deceased son. Yet it was found, that, by the mention of what the latter had suffered during his sickness, his recollection could usually be recalled. He continued to discharge his duty as Professor; but, notwithstanding some returns of a more vigorous intellect and fancy, he did not from this time resume his studies, and seldom answered the letters which he received. He was attacked with palsy in 1799, and afterwards sustained repeated shocks, the last in 1802. He lingered till the 18th of August 1803, when he expired at the age of 68. A particular *Account of his Life and Writings*, by Sir William Forbes of Pitligo, who had long been his friend and confidant, was published in 1806, in which are to be found some interesting selections from his private correspondence.

The character of Dr Beattie is delineated in his writings; of which the most prominent features are purity of sentiment, and warm attachment to the principles of religion and morality. His dispositions were gentle and modest, and he possessed great tenderness of heart. He was laborious in his literary pursuits, yet fond at all times of conversation and society. Towards the latter period of his life he was subject to an irritability of nerves, by which his temper was sensibly affected; and though, to appearance, his bodily frame was robust, he had impaired his strength by excess in study. He possessed considerable talents both for music and drawing.

His abilities as a writer may be said to have already undergone that ultimate test which is to be found in public opinion; and it has ranked him high as a moralist, a critic, and a poet. His *Essay on Truth* became a very popular book, particularly in England, and has gone through many editions. It must be confessed, that this work is not without considerable faults as a philosophical composition. Its leading doctrine has been thus stated by himself: "As we know nothing of the eternal relations of things, *that* to us is, and must be *truth*, which we feel that we must believe; and *that* to us is falsehood which we feel that we must disbelieve. I have shown that all

Beattie. genuine reasoning does ultimately terminate in certain principles which it is impossible to disbelieve, and as impossible to prove; that, therefore, the ultimate standard of truth to us is common sense, or that instinctive conviction into which all true reasoning does resolve itself." It is now generally admitted that, in the illustration of this doctrine, which is conformable in substance to that of Reid, Dr Beattie has fallen into some errors, or at least ambiguities, which the former has been enabled in a greater degree to avoid. What constitutes the chief defect of the *Essay* is a want of that strictness and precision, which a discussion of the metaphysical parts of the subject necessarily requires. He has used the term *common sense* with more latitude, and in a greater variety of significations, than is consistent with exact or conclusive reasoning; and he has stated some propositions too generally, and without the limitations which they seem to require. Notwithstanding this imperfection of the work, when considered strictly as a logical treatise, it is certain that many of the fundamental doctrines delivered in it carry with them an irresistible weight, which subsequent inquiry and discussion have tended, not to diminish, but increase. It may justly be considered as an example, in probable reasoning, of that indirect but conclusive mode of proof, which, in mathematical science, is usually termed *reductio ad absurdum*; a form which has been frequently and successfully employed by Dr Reid, for similar purposes. A reference to the sources of knowledge possessed by mankind in general, and to their common or universal sentiments, is an appeal regarding certain acknowledged facts, as an ingredient and ground-work of science. Nor is it to be supposed that, in these cases, philosophy surrenders her judgment to the popular opinion; but only, that the conclusions of the soundest and the most improved reason are conformable to the dictates of our faculties, as they are exercised by the majority of mankind. The materials of knowledge possessed by the philosopher and the vulgar are the same; it is in the extent of the inferences which are drawn from them, in their combination, and in the uses to which they are applied, that the disproportion is to be found. In their reasoning on mixed subjects, and in the power of remote calculations, men differ infinitely; in their immediate judgments they differ very little.

It is undeniable also, with respect to the style of this work, that Dr Beattie has fallen into an error, by using, on various occasions, a greater keenness of expression than is at all suited to the argumentative parts of his subject. An author may, indeed, be moved by a commendable feeling of indignation, to commence the task of writing, whatever be the subject of discussion. But he who attempts to conduct a train of reasoning, while under the immediate influence even of a just passion, engages in too difficult a matter, and foregoes many advantages. The truth is, that the metaphysical speculations of

* An interesting *Account of his Life and Character*, with a small collection of his compositions, in prose and verse, was printed by Dr Beattie in the year 1800.

Beattie.

Berkeley and Hume had proceeded so far in contradicting the ordinary apprehensions and feelings of mankind, as to prove, in the clearest manner, even to men of science, the impossibility of obtaining certain knowledge, by any exercise of the human intellect, altogether abstracted from the information of matter, and the employment of our other faculties; and those consequences with regard to morality, religion, and the social state, which appeared to flow as a necessary result from the speculative principles, particularly of Mr Hume, roused in a large class, both of the learned and unlearned, a sense of repugnance and opposition proportionally strong. Dr Beattie was among the first who endeavoured to resist the current of these opinions. His book was polemical; and that warmth of language, which he has not studied to repress, must be ascribed to these circumstances, if it cannot be defended by them.

But the objections in question are not applicable to any of his other works. It is impossible here to enter into a farther detail of these various publications. His *Elements of Moral Science*, and his different critical and philological treatises, are compositions of a very pleasing character; and it was chiefly by them that his reputation was established in other countries. Some of his books were early translated into the Dutch and other languages. A French translation of his *Essays on Poetry and Music* was printed at Paris in 1798. But it is chiefly as the author of the *Minstrel* that Beattie is known, and will continue to be admired. This poem, or rather poetical fragment, for the design was not completed, stands fully confirmed in the public favour; and it is sufficient to say, that, in beauty both of sentiment and imagery, it stands in the first class of poetical compositions. It would be difficult perhaps to select, from the body of English verse, any single passage which excels this stanza in the first part:

" O how can'st thou renounce the boundless store
Of charms, which Nature to her votary yields?
The waving woodland, the resounding shore,
The pomp of groves, the garniture* of fields,
All that the genial ray of morning gilds,
And all that echoes to the song of even,
All that the mountain's sheltering bosom shields,
And all the dread magnificence of heaven;
O how can'st thou renounce, and hope to be forgiven!"

It has been objected to the second part of the *Minstrel*, that it contains too much philosophy. But, though the instruction conveyed in it is frequently addressed to the understanding, it is never abstruse, and the lessons are those of a poet not less than of a moralist. Like the *Castle of Indolence*, it is, in scope and design, a didactic piece. Both commence in the highest strain of descriptive and pathetic

poetry; and the subsequent depression of tone in both is a necessary result of this lofty preparation. But the criticism is more just when applied to the work of Thomson, than to the *Minstrel*.

Dr Beattie's style is classical, and always perspicuous. He was never weary of retouching what he wrote, the chief secret of good composition, without which, at least, no composition can be rendered complete. He deserves, above all, that which is the greatest praise of an author, that no one can read his works with a candid mind, and rise from the perusal unimproved.

The following is a list of Dr Beattie's writings:—*Poems*, first published in 1760.—*Essay on Truth*, 1771.—*Minstrel*, 1771, 1774.—*Essays*, viz. On Poetry and Music—On Laughter and ludicrous Composition—On Classical Learning, 1776.—*Disquisitions*, viz. On Memory and Imagination—On Dreaming—On the Theory of Language—On Fable and Romance—On the Attachments of Kindred—and Illustrations of Sublimity, 1783.—*Evidences of Christianity*, 1786.—*Elements of Moral Science*, 1790, 1793. He likewise published, in 1790, an edition of Mr Addison's papers in the *Tatler*, *Spectator*, *Guardian*, and *Freeholder*, and of his treatise on the *Christian Religion*, with his Life by Tickell, and some original Notes, Edinburgh, 4 vols. 8vo. (EE.)

BEAUMARCHAIS (PIERRE AUGUSTIN CARON DE) appears to have been one of those persons who, from restlessness of disposition and singularity of character, obtain, in their own age, more celebrity than they are entitled to from their merit or talents. He was born at Paris in 1732, and was the son of a clockmaker, who brought him up to his own trade. From his earliest youth, however, he discovered an inclination for literature, together with a remarkable talent for music. His proficiency in that art procured him an introduction to the French court, where he was employed to teach the princesses, daughters of Louis XV. to play on the guitar. At their concerts, which he attended, he became acquainted with the banker Duverney, by whom he was instructed in business, and placed in a situation which was likely to lead to fortune. Beaumarchais first attracted public attention by his drama of *Eugenie*, which was published in 1767; but he was chiefly indebted for the notoriety he obtained, to the various law-suits in which he became involved after the death of his patron Duverney. Having commenced an action against the Count de la Blache, the grand-nephew of Duverney, for payment of a trifling balance of an account which was due to him by his deceased patron, and the suit having been removed from Aix to Paris, M. Gozman, one of the judges of the Parliament Maupeou, which was then very unpopular in the capital, was appointed to report and decide

Beattie
|
Beaumarchais.

* It is remarkable that this word should have been objected to by Gray, in his *Critique*, communicated to the author previously to the publication of the *Minstrel*. His reluctance to admit a term, which could only be rendered objectionable by being ranked with none but those of the highest and purest class in poetry, would of itself be a sufficient tribute to the diction of this beautiful passage. But Gray does ample justice to the whole stanza: "This," he exclaims, "is true poetry; this is inspiration."

Beumarchais.

on its merits. Beaumarchais suspecting that he was excluded from the presence of Goezman by the influence of the Count de la Blache, and thus prevented from explaining the merits of his case, bribed certain dependents of the judge in order to be admitted to an interview. The cause, however, was decided against him before he could obtain an audience, and the whole of the bribe not having been returned, a long correspondence took place, by which Goezman was at length so much exasperated, that he instituted a prosecution against Beaumarchais for an attempt to corrupt him in his judicial capacity. Beaumarchais was acquitted of the charge, while Goezman was found liable to him in damages, and was farther convicted of subornation and falsehood in his attempts to substantiate the accusation. The decision of Goezman having been rescinded, and the principal cause remitted to the Parliament of Aix, where it had originally depended, Beaumarchais again became involved with the Count de la Blache, in a litigation which originated in the calumnies and undue influence by which the Count attempted to overpower his adversary. In this dispute, Beaumarchais also prevailed; but the chief advantage which he acquired from these various processes was the astonishing interest and admiration which were universally excited in France by the *Factums* or *Mémoires* which he wrote in his defence; in which the most logical and convincing argument is diversified with the bitterest sarcasm, the keenest raillery, and the relation of incidents as strange and amusing as those which are met with in romance. These able and lively productions, however, procured him many enemies, as they discovered him to be a man of a most resentful and calumnious disposition. He also lost a good deal of the reputation he had acquired, from being involved in a new process, in which he found the advocate Bergasse a more formidable opponent than Goezman, or La Blache; and his new *Mémoires* wanted the spirit and gaiety to which his former ones were indebted for their popularity. Though occupied with these processes, and various literary pursuits, Beaumarchais did not neglect the improvement of his fortune. He engaged in various speculations, of which the most profitable was his project of supplying the Americans with arms and ammunition during the war with this country. Having thus gained a considerable fortune, he built a magnificent villa in the Faubourg St Antoine, which he embellished with much taste, and at great expence. He afterwards lost some part of the money he had acquired by an expensive and ill-executed edition of the works of Voltaire; and neither the early support which he gave to the principles of the French Revolution, nor his importation of fire-arms for the use of the French forces, were sufficient to preserve his property from confiscation, or his person from proscription. The sufferings and dangers which he experienced during this period, have been detailed by him in a work entitled, *Mes Six Époques*, which is written with considerable force and interest. After he had endured every species of accusation and persecution, and

had passed some time as an exile from his native country, he returned to France when the storms of the Revolution had subsided into a more settled tyranny, and having recovered possession of his villa in the Faubourg St Antoine, he remained there till his death, which happened suddenly in the year 1799.

The moral character of Beaumarchais seems to have been far from unexceptionable. He was remarkable for extraordinary indiscretion, restlessness, and ambition, an overweening conceit of his own talents, and an undisguised contempt for others. With these defects, it is not wonderful that his conduct should have formed the subject of some absurd calumnies. La Harpe mentions, that these were propagated to such an extent, that it was at one time reported, that he had made away, by poison, with his two wives whom he had successively married for their fortunes—a report, on which Voltaire is said to have remarked, "*ce Beaumarchais n'est point un empoisonneur—il est trop drôle.*" Even the journey which he undertook to Spain, in order to vindicate the honour, and secure the happiness of a sister, and which seems to have been the most praiseworthy action of his life, was made the subject of invidious misrepresentations, from which he has vindicated himself in one of his *Mémoires* against La Blache and Goezman.

Besides his *Mémoires*, Beaumarchais is the author of various dramatic productions, which made a great noise, and gained him considerable reputation in Paris at the time they appeared. His *Eugénie*, of which the plot is founded on a story in the *Diable Boiteux*, and his *Deux Amis*, which hinges on the embarrassment and perplexity of a merchant on the verge of insolvency, are serious sentimental comedies, written in imitation of Diderot's *Père de Famille*. *Eugénie*, which was the most successful of the two, is rather a romance carried on by dialogue, than a drama. It possesses little pathos or interest, and the only emotion felt in its perusal, is a certain degree of curiosity concerning the event of the story. The incidents in *Les Deux Amis* are flat and insipid, and as it is not sustained by the charms of versification, it fails almost entirely of theatrical effect. Beaumarchais obtained more success in his dramatic career, when he quitted the imitation of Diderot, and following the natural gaiety of his own genius, represented the lively and entertaining character of Figaro, in two successive pieces, *Le Barbier de Seville* and *La Folle Journée, ou le Mariage de Figaro*. The first of these comedies merely turns on the assistance which the Count Almaviva receives from Figaro, the *Barbier de Seville*, in his stratagem to carry off Rosine by duping an old guardian, by whom she was strictly watched, and who intended to marry her himself. The *Mariage de Figaro* principally hinges on the scheme devised by the Count Almaviva, of marrying a beautiful attendant of his countess to Figaro, with designs which seem to have been suggested by some scenes in the *Casina* of Plautus. Both pieces are full of lively dialogue, dramatic movement, and ingenious *jeux de theatre*. The author, however, had at first great difficulty in getting the *Mariage*

Beumarchais.

Beaumarchais
||
Beauty.

de Figaro represented; and the curiosity and expectation of the public were excited to the highest pitch, previous to its appearance. It continued to be acted twice a-week for two years, and produced immense profits both to the author and the comedians. To a reader of the present day, the chief interest of the *Mariage de Figaro* arises from the distress experienced by the countess, on finding herself forsaken by her husband, and the engaging, though not very moral, character of the page Cherubin; but in France its popularity might be partly owing to the numerous sarcasms both on the political and judicial administration of the country. This was evidently one of the author's chief objects, as he boasts in his preface, *qu'il a formé son plan de façon à y faire entrer la critique d'une foule d'abus qui desolent la société.* Beaumarchais has introduced Figaro a third time, in his last drama, *La Mere Coupable*; and it is generally supposed that by this character, in all the three dramas, he intended to represent himself. Figaro, it is true, is originally a barber, and afterwards a *valet*; but he is also a poet, a musician, and great intriguer, while the freedom which he uses with his master gives full scope for

the development of the character. In *La Mere Coupable*, he has also introduced, under the name of Begearss, his old opponent the advocate Bergasse. Indeed, he admits in his preface, *que Begearss n'est pas de son invention et qu'il l'a vu agir.*

Beaumarchais
||
Beauty.

Most of the plays of Beaumarchais are preceded by prefaces, in which he has vindicated them against objections, and pointed out their beauties; but, as he neither possessed much learning nor taste, his literary pleadings were not so happy as his judicial ones. Indeed, the great secret of Beaumarchais' success was the perceiving and availing himself of the tone and spirit of the times. The vogue in which the *Pere de Famille* then was, secured applause for his *Comedies Larmoyantes.* The unpopularity of a parliament, entrusted with the administration of justice, procured a favourable reception for his *Mémoires*; and the rising clamour against the government of the country, gave additional zest to the sarcasms of the *Mariage de Figaro.* Of consequence, Beaumarchais, during his life, was more celebrated than respectable, and the reputation he enjoyed in his own age was greater than that which he is likely to preserve with posterity. (M.)

BEAUTY.

BEAUTY,—that property in objects by which they are recommended to the power or faculty of **TASTE**—the reverse of Ugliness—the primary or most general object of love or admiration.

Necessary imperfection of definition, till it be settled whether our sense of Beauty be a simple sensation or otherwise.

These, we confess, are rather explanations of the word than definitions of the thing it signifies; and can be of no value, even as explanations of the word, except only to those who understand, without explanation, all the other words they contain. For, if the curious inquirer should proceed to ask, "And what is the faculty or power of Taste?" we do not see at present what other answer we could give, than that it was that of which Beauty was the object; or by which we were enabled to discover and to relish what was Beautiful. It is material, however, to observe, that if it could be made out, as some have alleged, that our perception of Beauty was a simple sensation, like our perception of colour; and that Taste was an original and distinct sense, like that of seeing or hearing; this would be truly the only definition that could be given, either of the sense or of its object—and all that we could do in investigating the nature of the latter, would be to digest and enumerate the circumstances under which it was found to present itself to its appropriate organ. All that we can say of colour, if we consider it very strictly, is, that it is that property in objects by which they are recommended to the faculty of sight; and the faculty of sight can scarcely be defined in any other way than as that by which we are enabled to discover the existence of colour. When we attempt to proceed farther, and say that Green is the colour of grass, and Red of roses or blood, it is plain that we do not in any respect explain the nature of those colours, but

only give instances of their occurrence; and that one who had never seen them could learn nothing whatever from these pretended definitions. Complex ideas, on the other hand, and compound emotions, may be always defined, and explained to a certain extent, by enumerating the parts of which they are made up, or resolving them into the elements of which they are composed:—and we may thus acquire, not only a substantial knowledge of their nature, but a practical power in their regulation or production.

It becomes of importance, therefore, in the very outset of this inquiry, to consider whether our sense of Beauty be really a simple sensation, like some of those we have enumerated, or a compound or derivative feeling, the sources or elements of which may be investigated and ascertained. If it be the former, we have then only to refer it to the peculiar sense or faculty of which it is the object; and to determine, by repeated observation, under what circumstances it occurs:—But, if it be the latter, we have to proceed, by a joint process of observation and reflection, to ascertain what are the primary feelings to which it may be referred; and by what peculiar modification of them it is produced and distinguished. We are not quite prepared, as yet, to exhaust the whole of this important discussion, to which we shall be obliged to return in the sequel of our inquiry; but it is necessary, in order to explain and to set forth, in their natural order, the difficulties with which the subject is surrounded, to state here, in a very few words, one or two of the most obvious, and, as we think, decisive objections against the notion of Beauty being a simple sensation, or the object of a separate and peculiar faculty.

State of the question on this point.

Beauty.
First reason against the notion of Beauty being a peculiar quality, and the object of a distinct Sense or Faculty,—that those who have the Faculty do not recognise this quality in the same objects.

The first, and perhaps the most considerable, is the want of agreement as to the presence and existence of Beauty in particular objects, among men whose organization is perfect, and who are plainly possessed of the faculty, whatever it may be, by which Beauty is discerned. Now, no such thing happens, we imagine, or can be conceived to happen, in the case of any other simple sensation, or the exercise of any other distinct faculty. Where one man sees light, all men who have eyes, see light also.—All men allow grass to be green—and sugar to be sweet, and ice to be cold,—and the unavoidable inference from any apparent disagreement in such matters necessarily is, that the party is insane, or entirely destitute of the sense or organ concerned in the perception. With regard to Beauty, however, it is obvious, at first sight, that the case is quite different. One man sees it perpetually, where to another it is quite invisible,—or even where its reverse seems to be conspicuous. Nor is this owing to the insensibility of either of the parties—for the same contrariety exists where both are keenly alive to the influences of the Beauty they respectively discern. A Chinese or African lover would probably see nothing at all attractive in a belle of London or Paris,—and undoubtedly, an *elegans formarum spectator*, from either of these cities, would discover nothing but deformity in the Venus of the Hot-tentots. A little distance in time produces the same effects as distance in place;—the gardens, the furniture, the dress, which appeared beautiful in the eyes of our grandfathers, are odious and ridiculous in ours. Nay, the difference of rank, education, or employments, give rise to the same diversity of sensation. The little shopkeeper sees a Beauty in his roadside box, and in the staring tile roof, wooden lions, and clipped boxwood, which strike horror into the soul of the student of the picturesque,—while he is transported in surveying the fragments of ancient sculpture, which are nothing but ugly masses of mouldering stone, in the judgment of the admirer of neatness. It is needless, however, to multiply instances, since the fact admits of no contradiction. But how can we believe, that Beauty is the object of a peculiar sense or faculty, when persons undoubtedly possessed of the faculty, and even in an eminent degree, can discover nothing of it in objects where it is distinctly felt and perceived by others with the same use of the faculty?

Second reason—the infinite variety of objects to which the quality of Beauty must be held to belong.

This one consideration, we confess, appears to us conclusive against the supposition of Beauty being a real property of objects, addressing itself to the power of Taste as a separate sense or faculty,—and seems to point irresistibly to the conclusion, that our sense of it is the result of other more elementary feelings, into which it may be analyzed or resolved. A second objection, however, if possible of still greater force, is suggested, by considering the prodigious and almost infinite variety of things to which this property of Beauty is ascribed, and the impossibility of imagining any one inherent quality which can belong to them all, and yet, at the same time, possess so much unity as to be the peculiar object of a separate sense or faculty. All simple qualities that are perceived in any one object, are immediately

Beauty.
recognised to be *the same*, when they are again perceived in another; and the objects in which they are thus perceived, are at once felt so far to resemble each other, and to partake of the same nature. Thus snow is seen to be white, and chalk is seen to be white; but this is no sooner seen, than the two substances, however unlike in other respects, are felt at once to have this quality in common, and to resemble each other in all that relates to the quality of colour, and the sense of seeing. Now, is this felt, or could it even be intelligibly asserted, with regard to the quality of Beauty? Take even a limited and specific sort of Beauty,—for instance the Beauty of Form. The form of a fine tree is beautiful—and the form of a fine woman,—and the form of a column, and a vase, and a chandelier. Yet how can it be said that the form of a woman has anything in common with that of a tree or a temple? or to which of the senses by which forms are distinguished, does it appear they have any resemblance or affinity?

The matter, however, becomes still more inextricable when we recollect that Beauty does not belong merely to forms or colours, but to sounds, and perhaps to the objects of other senses; nay, that in all languages and in all nations, it is not supposed to reside exclusively in material objects, but to belong also to sentiments and ideas, and intellectual and moral existences. Not only is a tree Beautiful, as well as a palace or a waterfall; but a poem is Beautiful, and a theorem in mathematics, and a contrivance in mechanics. But if things intellectual and totally segregated from matter may thus possess Beauty, how can it possibly be a quality of material objects? Or what sense or faculty can that be, whose proper office it is to intimate to us the existence of some property which is common to a flower and a demonstration, a valley and an eloquent discourse?

The only answer which occurs to this, is plainly enough a bad one; but the statement of it, and of its insufficiency, will serve better, perhaps, than anything else, to develop the actual difficulties of the subject, and the true state of the question with regard to them. It may be said, then, in answer to the questions we have suggested above, that all these objects, however various and dissimilar, agree at least in being Agreeable, and that this *Agreeableness*, which is the only quality they possess in common, may probably be the Beauty which is ascribed to them all. Now, to those who are accustomed to such discussions, it would be quite enough to reply, that though the Agreeableness of such objects depend plainly enough upon their Beauty, it by no means follows, but quite the contrary, that their Beauty depends upon their Agreeableness; the latter being the more comprehensive or generic term, under which Beauty must rank as one of the species. Its nature, therefore, is no more explained, nor is less absurdity substantially committed, by saying that things are Beautiful, because they are Agreeable, than if we were to give the same explanation of the sweetness of sugar; for no one, we suppose, will dispute, that though it be very true that sugar is agreeable because it is sweet, it would be manifestly preposterous to say that it was sweet because it was agreeable. For the bene-

Suggestion that their Agreeableness may be their common quality
refuted, by general Considerations,

Beauty. fit, however, of those who wish or require to be more regularly initiated in these mysteries, we beg leave to add a few observations.

and more particularly. In the first place, then, it seems evident, that Agreeableness, in general, cannot be the same with Beauty, because there are very many things in the highest degree Agreeable, that can in no sense be called Beautiful. Moderate heat, and savoury food, and rest, and exercise, are Agreeable to the body; but none of these can be called Beautiful; and among objects of a higher class, the love and esteem of others, and fame, and a good conscience, and health, and riches, and wisdom, are all eminently Agreeable; but not at all Beautiful, according to any intelligible use of the word. It is plainly quite absurd, therefore, to say that Beauty consists in Agreeableness, without specifying in consequence of what it is agreeable,—or to hold that anything whatever is taught as to its nature, by merely classing it among our pleasurable emotions.

In the second place, however, we may remark, that among all the objects that are Agreeable, whether they are also Beautiful or not, scarcely any two are Agreeable on account of the same qualities, or even suggest their agreeableness to the same faculty or organ. Most certainly there is no resemblance or affinity whatever between the qualities which make a peach agreeable to the palate, and a beautiful statue to the eye; which soothe us in an easy chair by the fire, or delight us in a philosophical discovery. The truth is, that Agreeableness is not properly a quality of any object whatsoever, but the effect or result of certain qualities, the nature of which we can generally define pretty exactly, or of which we know at least with certainty that they manifest themselves respectively to some one particular sense or faculty, and to no other; and consequently it would be just as obviously ridiculous to suppose a faculty or organ, whose office it was to perceive Agreeableness, as to suppose that Agreeableness was a distinct quality that could thus be perceived.

The class of agreeable objects, thanks to the bounty of Providence, is exceedingly large. Certain things are agreeable to the palate, and others to the smell and to the touch. Some again are agreeable to our faculty of imagination, or to our understanding, or to our moral feelings; and none of all these we call Beautiful. But there are others which we do call Beautiful; and those we say are agreeable to our faculty of Taste;—but when we come to ask what is the faculty of Taste, and what are the qualities which recommend them to that faculty?—we find ourselves just where we were at the beginning of the discussion, and embarrassed with all the difficulties arising from the prodigious diversity of objects which seem to possess these qualities.

We know pretty well what is the faculty of seeing or hearing; or, at least, we know that what is agreeable to one of those faculties, has no effect whatever on the other. We know that bright colours afford no delight to the ear, nor sweet tones to the eye; and are therefore perfectly assured that the qualities which make the visible objects agreeable, cannot be the same with those which give pleasure to the ear. But it is by the eye and by the ear that

Beauty. all material Beauty is perceived; and yet the Beauty which discloses itself to these two separate senses, and plainly depends upon qualities which have no sort of affinity, is supposed to be one distinct quality, and to be perceived by a peculiar sense or faculty! The perplexity becomes still greater when we think of the Beauty of poems or theorems, and endeavour to imagine what qualities they can possess in common with the agreeable modifications of light or of sound.

It is in these considerations undoubtedly that the difficulty of the subject consists. The faculty of Taste, plainly, is not a faculty like any of the external senses—the range of whose objects is limited and precise, as well as the qualities by which they are gratified or offended,—and Beauty, accordingly, is discovered in an infinite variety of objects, among which it seems, at first sight, impossible to discover any other bond of connexion. Yet boundless as their diversity may appear, it is plain that they *must* resemble each other in *something*, and in something more definite and definable than merely in being agreeable;—since they are all classed together, in every tongue and nation, under the common appellation of Beautiful, and are felt indeed to produce emotions in the mind that have some sort of kindred or affinity. The words Beauty and Beautiful, in short, must mean something; and are universally felt to mean something much more definite than agreeableness or gratification in general; and while it is confessedly by no means easy to describe or define what that something is, the force and clearness of our perception of it is demonstrated by the readiness with which we determine, in any particular instance, whether the object of a given pleasurable emotion is or is not properly described as Beauty.

What we have already said, we confess, appears to us conclusive against the idea of this Beauty being any fixed or inherent property of the objects to which it is ascribed, or itself the object of any separate and independent faculty; and we will no longer conceal from the reader what we take to be the true solution of the difficulty. In our opinion, then, our sense of Beauty depends entirely on our previous experience of simpler pleasures or emotions, and consists in the *suggestion* of agreeable or interesting sensations with which we had formerly been made familiar by the direct and intelligible agency of our common sensibilities:—and that vast variety of objects, to which we give the common name of Beautiful, become entitled to that appellation, merely because they all possess the power of recalling or reflecting those sensations of which they have been the accompaniments, or with which they have been associated in our imagination by any other more casual bond of connection. According to this view of the matter, therefore, Beauty is not an inherent property or quality of objects at all, but the result of the accidental relations in which they may stand to our experience of pleasures or emotions,—and does not depend upon any particular configuration of parts, proportions, or colours, in external things, nor upon the unity, coherence, or simplicity of intellectual creations,—but merely upon the associations which, in the case of every individual, may enable these inherent, and otherwise indifferent qualities, to suggest or recal to the mind emotions of a pleasurable nature.

Beauty. able or interesting description. It follows, therefore, that no object is beautiful in itself,—or could appear so, antecedent to our experience of direct pleasures or emotions; and that, as an infinite variety of objects may thus reflect interesting ideas, so all of them may acquire the title of Beautiful, although utterly diverse and disparate in their nature, and possessing nothing in common but this accidental power of reminding us of other emotions.

This theory, which, we believe, is now very generally adopted, though under many needless qualifications, shall be farther developed and illustrated in the sequel. But at present we shall only remark, that it serves at least to solve the great problem involved in the discussion, by rendering it easily conceivable how objects which have no inherent resemblance, nor, indeed, any one quality in common, should yet be united in one common relation, and consequently acquire one common epithet,—just as all the things that belonged to a beloved individual may serve to remind us of him, and thus to awake a kindred class of emotions, though just as unlike each other as any of the objects that are classed under the general name of Beautiful. His poetry, for instance, or his slippers,—his acts of bounty, or his saddlehorse,—may lead to the same chain of interesting remembrances, and thus agree in possessing a power of excitement, for the sources of which we should look in vain through all the variety of their physical or metaphysical qualities.

By the help of the same consideration, we get rid of all the mystery of a peculiar sense or faculty, imagined for the express purpose of perceiving Beauty; and discover that the power of Taste is nothing more than the habit of tracing those associations, by which almost all objects may be connected with interesting emotions. It is easy to understand, that the recollection of any scene of delight or emotion must produce a certain agreeable sensation, and that the objects which introduce these recollections should not appear altogether indifferent to us: Nor is it, perhaps, very difficult to imagine, that recollections thus strikingly suggested by some real and present existence, should present themselves under a different aspect, and move the mind somewhat differently from those which arise spontaneously in the ordinary course of our reflections, and do not thus grow out of a direct and peculiar impression.

The whole of this doctrine, however, we shall endeavour by and by to establish upon more direct evidence; but having now explained, in a general way, both the difficulties of the subject, and our suggestion as to their true solution, it is proper that we should take a short review of the more considerable theories that have been proposed for the elucidation of this curious question; which is one of the most delicate, as well as the most popular in the science of metaphysics,—was one of the earliest which exercised the speculative ingenuity of philosophers,—and has at last, we think, been more successfully treated than any other of a similar description.

In most of these speculations, we shall find rather imperfect truth, than fundamental error:—or, at all events, such errors only as arise naturally from that peculiar difficulty which we have already endeavoured to

explain, as consisting in the prodigious multitude and diversity of the objects in which the common quality of Beauty was to be accounted for. Those who have not been sufficiently aware of the difficulty have generally dogmatized from a small number of instances, and have rather given examples of the occurrence of Beauty in some few classes of objects, than afforded any light as to that upon which it essentially depended in all—while those who felt its full force have very often found no other resource, than to represent Beauty as consisting in properties so extremely vague and general (such, for example, as the power of exciting ideas of relation), as almost to elude our comprehension, and, at the same time, of so abstract and metaphysical a description, as not to be very intelligibly stated, as the radicals of a strong, familiar, and pleasurable emotion. This last observation leads us to make one other remark upon the general character of these theories; and this is, that some of them seem necessarily to imply the existence of a peculiar sense or faculty for the perception of Beauty; as they resolve it into properties that are not in any way interesting or agreeable to any of our known faculties. Such are all those which make it consist in Proportion,—or in Variety, combined with Regularity,—or in waving lines,—or in Unity,—or in the perception of Relations,—without explaining, or attempting to explain, how any of these things should affect us with any delight or emotion. Others, again, do not require the supposition of any such separate faculty; because in them the sense of Beauty is considered as arising from other more simple and familiar emotions, which are in themselves and beyond all dispute agreeable. Such are those which teach that Beauty depends on the perception of Utility, or of Design, or Fitness, or in tracing Associations between its objects and the common joys or emotions of our nature. Which of these two classes of speculation, to one or other of which, we believe, all theories of Beauty may be reduced, is the most philosophical in itself, we imagine can admit of no question; and we hope in the sequel to leave it as little doubtful, which is to be considered as most consistent with the fact. In the mean time, we must give a short account of some of the theories themselves.

The most ancient of which it seems necessary to take any notice, is that which may be traced in the Dialogues of Plato,—though we are very far from pretending that it is possible to give any intelligible or consistent account of its tenor. It should never be forgotten, however, that it is to this subtle and ingenious spirit, that we owe the suggestion, that it is *Mind* alone that is Beautiful; and that, in perceiving Beauty, it only contemplates the shadow of its own affections;—a doctrine which, however mystically unfolded in his writings, or however combined with extravagant or absurd speculations, unquestionably carries in it the germ of all the truth that has since been revealed on the subject. By far the largest dissertation, however, that this great philosopher has left upon the nature of Beauty, is to be found in the dialogue entitled *the Greater Hippias*, which is entirely devoted to that inquiry. We do not learn a great deal of the author's own opinion, indeed, from this performance; for it is one of

Beauty. Speculations of Plato on the Subject.

Short historical View of the Theories proposed on the Subject.

General Remarks on these Theories.

Beauty.

the dialogues which have been termed *Anatreptic* or confuting,—in which nothing is concluded in the affirmative, but a series of sophistical suggestions or hypotheses are successively exposed. The plan of it is to lead on Hippias, a shallow and confident sophist, to make a variety of dogmatical assertions as to the nature of Beauty, and then to make him retract and abandon them upon the statement of some obvious objections. Socrates and he agree at first in the notable proposition, “that Beauty is that by which all Beautiful things are Beautiful;” and then, after a great number of suggestions, by far too childish and absurd to be worthy of any notice, such as, that the Beautiful may peradventure be gold, or a fine woman, or a handsome mare, they at last get to some suppositions, which show that almost all the theories that have since been propounded on this interesting subject, had occurred thus early to the active and original mind of this keen and curious inquirer. Thus Socrates first suggests, that Beauty may consist in the Fitness or suitableness of any object to the place it occupies, and afterwards, more generally and directly, that it may consist in Utility,—a notion which is ultimately rejected, however, upon the subtle consideration that the useful is that which produces good, and that the producer and the product being necessarily different, it would follow, upon that supposition, that beauty could not be good, nor good beautiful. Finally, he suggests, that Beauty may be the mere organic delight of the eye or the ear,—to which, after stating very slightly the objection, that it would be impossible to account upon this ground for the Beauty of poetry or eloquence, he proceeds to rear up a more refined and elaborate refutation, upon such grounds as these:—If Beauty be the proper name of that which is naturally agreeable to the sight and hearing, it is plain, that the objects to which it is ascribed must possess some common and distinguishable property, besides that of being agreeable, in consequence of which, they are separated and set apart from objects that are agreeable to our *other* senses and faculties, and, at the same time, classed together under the common appellation of Beautiful.—Now, we are not only quite unable to discover what this property is, but it is manifest, that objects which make themselves known to the ear, *can* have no property as such, in common with objects that make themselves known to the eye; it being impossible that an object which is beautiful by its colour, can be beautiful, from the same quality, with another which is beautiful by its sound. From all which it is inferred, that, as Beauty is admitted to be something real, it cannot be merely what is agreeable to the organs of sight or hearing.

There is no practical wisdom, we admit, in those fine drawn speculations; nor any of that spirit of patient observation by which alone any sound view of such objects can ever be attained. There are also many marks of that singular incapacity to distinguish between what is absolutely puerile and silly, and what is plausible, at least, and ingenious, which may be reckoned among the characteristics of “the divine philosopher,” and in some degree of all the philosophers of antiquity: But they show clearly enough the subtle and abstract character of Greek

speculation, and prove at how early a period, and to how great an extent, the inherent difficulties of the subject were felt, and produced their appropriate effects.

There are some hints on these subjects in the works of Xenophon, and some scattered observations in those of Cicero, who was the first, we believe, to observe, that the sense of Beauty is peculiar to Man;—but nothing else, we believe, in classical antiquity, which requires to be analyzed or explained. It appears that St Augustin composed a large treatise on Beauty; and it is to be lamented, that the speculations of that acute and ardent genius on such a subject have been lost. We discover, from incidental notices in other parts of his writings, that he conceived the Beauty of all objects to depend on their Unity,—or on the perception of that Principle or Design which fixed the relations of their various parts, and presented them to the intellect or imagination as one harmonious whole. It would not be fair to deal very strictly with a theory with which we are so imperfectly acquainted: But it may be observed, that, while the author is so far in the right as to make Beauty consist in a relation to mind, and not in any physical quality, he has taken far too narrow and circumscribed a view of the matter, and one which seems almost exclusively applicable to works of human art; it being plain enough, we think, that a beautiful landscape, or a beautiful horse, has no more unity, and no more traces of design, than one which is not beautiful.

We do not pretend to know what the Schoolmen taught upon this subject during the dark ages; but the discussion does not seem to have been resumed for long after the revival of letters. The followers of Leibnitz were pleased to maintain, that Beauty consisted in Perfection; but what constituted Perfection they did not attempt to define. M. Crouzas wrote a long essay, to show that Beauty depended on these five elements, Variety, Unity, Regularity, Order, and Proportion; and the Pere André, a still longer one to prove, that, admitting these to be the true foundations of Beauty, it was still most important to consider, that the Beauty which results from them is either Essential, or Natural, or Artificial,—and that it may be greater or less, according as the characteristics of each of these classes are combined or set in opposition.

Among ourselves, we are not aware of any considerable publication on the subject till the appearance of Lord Shaftesbury's *Characteristics*, in which a sort of rapturous Platonic doctrine is delivered as to the existence of a primitive and Supreme Good and Beauty, and of a certain internal sense, by which both Beauty and moral merit were distinguished. Addison published several ingenious papers in *The Spectator*, on the pleasures of the imagination, and was the first, we believe, who referred them to the specific sources of Beauty, Sublimity, and Novelty. He did not enter much, however, into the metaphysical discussion of the nature of Beauty itself; and the first philosophical treatise of note that appeared on the subject, may be said to have been the *Inquiry* of Dr Hucheson, first published, we believe, in 1725.

In this work, the notion of a peculiar internal

Beauty.

Doctrine of St Augustin, that Beauty consists in Unity.

Opinions of Crouzas and André.

Of Lord Shaftesbury.

Of Addison.

Dr Hucheson's Doctrine of an internal or reflex Sense, by which Beauty is discovered.

Beauty. sense, by which we are made sensible of the existence of Beauty, is very boldly promulgated, and maintained by many ingenious arguments: Yet nothing, we conceive, can be more extravagant than such a proposition; and nothing but the radical faults of the other parts of the hypothesis could possibly have driven the learned author to its adoption. Even after the existence of this sixth sense was assumed, he felt that it was still necessary that he should explain what were the qualities by which it was gratified; and these, he was pleased to allege, were nothing but the combinations of Variety with Uniformity; all objects, as he has himself expressed it, which are equally Uniform, being Beautiful in proportion to their Variety,—and all objects equally various being Beautiful in proportion to their Uniformity. Now, not to insist upon the obvious and radical objection that this is not true in fact, as to flowers, landscapes, or indeed of any thing but architecture, if it be true of that,—it could not fail to strike the ingenious author that these qualities of Uniformity and Variety were not of themselves agreeable to any of our known senses or faculties, except when considered as symbols of Utility or Design, and therefore could not intelligibly account for the very lively emotions which we often experience from the perception of Beauty, where the notion of design or utility was not at all suggested. He was constrained, therefore, either to abandon this view of the nature of Beauty altogether, or to imagine a new sense or faculty, whose characteristic and description it should be to receive delight from the combinations of Uniformity and Variety, without any consideration of their being significant of things agreeable to our other faculties; and this being accomplished by the mere force of the assumption and the definition, there was no room for farther dispute or difficulty in the matter.

This Sense excited by the combination of Uniformity and Variety.

Attempts to resolve Beauty into Uniformity and Variety without the supposition of a separate Sense.

But quite unsatisfactory.

Some of Hucheson's followers, such as Gerard and others, who were a little startled at the notion of a separate faculty, and yet wished to retain the doctrine of Beauty depending on Variety and Uniformity, endeavoured, accordingly, to show that these qualities were naturally agreeable to the mind, and were recommended by considerations arising from its most familiar properties. Uniformity or Simplicity, it is said, renders our conception of objects easy, and saves the mind from all fatigue and distraction in the consideration of them; whilst Variety, if circumscribed and limited by an ultimate uniformity, gives it a pleasing exercise and excitement, and keeps its energies in a state of pleasurable activity. Now, this appears to us to be mere trifling. The varied and lively emotions which we receive from the perception of Beauty, obviously have no sort of resemblance to the pleasure of moderate intellectual exertion; nor can anything be conceived more utterly dissimilar than the gratification we have in gazing on the form of a lovely woman, and the satisfaction we receive from working an easy problem in arithmetic or geometry. If a triangle is more beautiful than a regular polygon, as those authors maintain, merely because its figure is more easily comprehended, the number *four* should be more beautiful than the number three hundred and twenty-seven, and the form of a gibbet far more agreeable than that

of a branching oak. The radical error, in short, consists in fixing upon properties that are not interesting in themselves, and can never be conceived, therefore, to excite any emotion, as the fountain-spring of all our emotions of Beauty: And it is an absurdity that must infallibly lead to others,—whether these take the shape of a violent attempt to disguise the truly indifferent nature of the properties so selected, or of the bolder expedient of creating a peculiar faculty, whose office it is to find them interesting.

Beauty.

The next remarkable theory was that proposed by Edmund Burke, in his *Treatise of the Sublime and Beautiful*. But of this, in spite of the great name of the author, we cannot persuade ourselves that it is necessary to say much. His explanation is founded upon a species of materialism,—not much to have been expected from the general character of his genius, or the strain of his other speculations,—for it all resolves into this,—that all objects appear Beautiful, which have the power of producing a peculiar relaxation of our nerves and fibres, and thus inducing a certain degree of bodily languor and sinking. Of all the suppositions that have been at any time hazarded to explain the phenomena of Beauty, this, we think, is the most unfortunate, and the most weakly supported. There is no philosophy in the doctrine,—and the fundamental assumption is in every way contradicted by the most familiar experience. There is no relaxation of the fibres in the perception of Beauty,—and there is no pleasure in the relaxation of the fibres. If there were, it would follow, that a warm bath would be by far the most beautiful thing in the world—and that the brilliant lights, and bracing airs of a fine autumn morning, would be the very reverse of Beautiful. Accordingly, though the treatise alluded to will always be valuable on account of the many fine and just remarks it contains, we are not aware that there is any accurate inquirer into the subject (with the exception, perhaps, of Mr Price, in whose hands, however, the doctrine assumes a new character) by whom the fundamental principle of the theory has not been explicitly abandoned.

Theory of Burke, that things are Beautiful which produce a relaxation of the Fibres.

A yet more extravagant doctrine was soon afterwards inculcated, and in a tone of great authority, in a long article from the brilliant pen of Diderot, in the French *Encyclopédie*, and one which exemplifies, in a very striking manner, the nature of the difficulties with which the discussion is embarrassed. This ingenious person, perceiving at once, that the Beauty which we ascribe to a particular class of objects, could not be referred to any peculiar and inherent quality in the objects themselves, but depended upon their power of exciting certain sentiments in our minds; and being, at the same time, at a loss to discover what common power could belong to so vast a variety of objects as pass under the general appellation of Beautiful, or by what tie all the various emotions which are excited by the perception of Beauty could be united, was at last driven, by his sense of the necessity of keeping his definition sufficiently wide and comprehensive, to hazard the strange assertion, that all objects were Beautiful which excite in us the idea of *relation*; that

Of Diderot, that our Sense of Beauty is merely a perception of Relation.

Beauty. our sense of Beauty consisted in tracing out the relations which the object possessing it might have to other objects; and that its Beauty was in proportion to the number and clearness of the relations thus suggested and perceived. It is scarcely necessary, we presume, to expose by any arguments the manifest fallacy, or rather the palpable absurdity of such a theory as this. In the first place, we conceive it to be obvious, that all objects whatever have an infinite, and consequently an equal number of relations, and are equally likely to suggest them to those to whom they are presented;—at all events, it is certain, that ugly and disagreeable objects have just as many relations as those that are agreeable, and ought, therefore, to be just as Beautiful, if the sense of Beauty consists in the perception of relations. In the next place, it seems to be sufficiently certain, from the experience and common feelings of all men, that the perception of relations among objects is not in itself accompanied by any pleasure whatever, and in particular has no conceivable resemblance to the emotion we receive from the perception of Beauty. When we perceive one ugly old woman sitting exactly opposite to two other ugly old women, and observe, at the same moment, that the first is as big as the other two taken together, we humbly conceive, that this clear perception of the relations in which these three Graces stand to each other, cannot well be mistaken for a sense of Beauty, and that it does not in the least abate or interfere with our sense of their ugliness. Finally, we may observe, that the sense of Beauty results instantaneously from the perception of the object; whereas the discovery of its relations to other objects must necessarily be a work of time and reflection, in the course of which the beauty of the object, so far from being created or brought into notice, must, in fact, be lost sight of and forgotten.

Theory of Father Buffier and Sir Joshua Reynolds,—that Beauty consisted in what was most common and familiar.

Another more plausible and ingenious theory was suggested by the Pere Buffier, and afterwards adopted and illustrated with great talent in the *Discourses* of Sir Joshua Reynolds. According to this doctrine, Beauty consists, as Aristotle held virtue to do, in mediocrity, or conformity to that which was most usual. Thus a beautiful nose, to make use of Dr Smith's very apt illustration of this doctrine, is one that is neither very long nor very short,—very straight nor very much bent,—but of an ordinary form and proportion, compared with all the extremes. It is the form, in short, which nature seems to have aimed at in all cases, though she has more frequently deviated from it than hit it; but deviating from it in all directions, all her deviations come nearer to it than they ever do to each other. Thus the most beautiful in every species of creatures bears the greatest resemblance to the whole species, while monsters are so denominated because they bear the least; and thus the Beautiful, though in one sense the rarest, as the exact medium is but seldom hit, is invariably the most common, because it is the central point from which all the deviations are the least remote. This view of the matter is adopted by Sir Joshua in its full extent, and is even carried so far by this great artist, that he does not scruple to conclude, "That if we were more used to deformity than Beauty, deformity would then lose the idea that is now annexed

to it, and take that of Beauty;—just as we approve and admire fashions in dress, for no other reason than that we are used to them."

Now, not to dwell upon the very startling conclusion to which these principles must lead, viz. that things are Beautiful in proportion as they are ordinary; and that it is merely their familiarity which constitutes their Beauty, we would observe, in the first place, that the whole theory seems to have been suggested by a consideration of animal forms, or perhaps of the human figure exclusively. In these forms, it is quite true that great and monstrous deviations from the usual proportions are extremely disagreeable. But this, we have no doubt, arises entirely from some idea of pain or disaster attached to their existence, or from their obvious unfitness for the functions they have to perform. In vegetable forms, accordingly, these irregularities excite no such disgust; it being, in fact, the great object of culture, in almost all the more beautiful kinds, to produce what may be called monstrosities. And, in mineral substances, where the idea of suffering is still more completely excluded, it is notorious that, so far from the more ordinary configurations being thought the most Beautiful, this epithet is scarcely ever employed but to denote some rare and unusual combination of veins, colours, or dimensions. As to landscapes, again, and almost all the works of art, without exception, the theory is plainly altogether incapable of application. In what sense, for example, can it be said that the Beauty of natural scenery consists in mediocrity; or that these landscapes are the most Beautiful that are the most common? or what meaning can we attach to the proposition, that the most Beautiful building, or picture, or poem, is that which bears the nearest resemblance to all the individuals of its class, and is, upon the whole, the most ordinary and common?

To a doctrine which is liable to these obvious and radical objections, it is not perhaps necessary to make any other; but we must remark farther, first, That it necessarily supposes that our sense of Beauty is, in all cases, preceded by such a large comparison between various individuals of the same species, as may enable us to ascertain that average or mean form in which Beauty is supposed to consist; and, consequently, that we could never discover any object to be Beautiful antecedent to such a comparison; and, secondly, That, even if we were to allow that this theory afforded some explanation of the superior Beauty of any one object, compared with others of the same class, it plainly furnishes no explanation whatever of the superior Beauty of one class of objects compared with another. We may believe, if we please, that one peacock is handsomer than another, because it approaches more nearly to the average or mean form of peacocks in general; but this reason will avail us nothing whatever in explaining why any peacock is handsomer than any pelican or penguin. We may say, without manifest absurdity, that the most beautiful pig is that which has least of the extreme qualities that sometimes occur in the tribe; but it would be palpably absurd to give this reason, or any thing like it, for the superior Beauty of the tribe of antelopes or spaniels.

The notion, in short, seems to have been hastily

Beauty. adopted by the ingenious persons who have maintained it, partly upon the narrow ground of the disgust produced by monsters in the animal creation, which has been already sufficiently explained,—and partly in consequence of the fallacy which lurks in the vague and general proposition of these things being beautiful which are neither *too* big nor *too* little, *too* massive nor *too* slender, &c.; from which it was concluded, that Beauty must consist in mediocrity:—not considering that the particle *too* merely denotes those degrees which are exclusive of Beauty, without in any way fixing what those degrees are. For the plain meaning of these phrases is, that the rejected objects are *too* massive or *too* slender *to be beautiful*; and, therefore, to say that an object is beautiful which is neither *too* big nor *too* little, &c. is really saying nothing more than that beautiful objects are such as are not in any degree ugly or disagreeable. The illustration as to the effects of use or custom in the article of dress is singularly inaccurate and delusive; the fact being, that we never admire the dress which we are most accustomed to see,—which is that of the common people,—but the dress of the few who are distinguished by rank or opulence; and that we require no more custom or habit to make us admire this dress, whatever it may be, than is necessary to associate it in our thoughts with the wealth and dignity of those who wear it.

Beauty. the ordinary affections or emotions of our nature; and in this, which is the fundamental point of his theory, we conceive him to be no less clearly right, than he is convincing and judicious, in the copious and beautiful illustration by which he has sought to establish its truth. When he proceeds, however, to assert, that our sense of Beauty consists not merely in the suggestion of ideas of emotion, but in the contemplation of a *connected series* of such ideas, and indicates a state of mind in which the faculties, half active and half passive, are given up to a sort of reverie or musing, in which they may wander, though among kindred impressions, far enough from the immediate object of perception, we will confess that he not only seems to us to advance a very questionable proposition, but very essentially to endanger the evidence, as well as the consistency, of his general doctrine. We are far from denying, that, in minds of sensibility and of reflecting habits, the contemplation of beautiful objects will be apt, especially in moments of leisure, and when the mind is vacant, to give rise to such trains of thought, and to such protracted meditations; but we cannot possibly admit that their existence is necessary to the perception of Beauty, or that it is in this state of mind exclusively that the sense of Beauty exists. The perception of Beauty, on the contrary, we hold to be, in most cases, quite instantaneous, and altogether as immediate as the perception of the external qualities of the object to which it is ascribed. Indeed, it seems only necessary to recollect, that it is to a present material object that we actually ascribe and refer this Beauty, and that the only thing to be explained is, how this object comes to appear Beautiful. In the long train of interesting meditations, however, to which Mr Alison refers,—in the delightful reveries in which he would make the sense of Beauty consist,—it is obvious that we must soon lose sight of the external object which gave the first impulse to our thoughts; and though we may afterwards reflect upon it, with increased interest and gratitude, as the parent of so many charming images, it is impossible, we conceive, that the perception of *its* Beauty can ever depend upon a long series of various and shifting emotions.

Embarrassed by the supposition of connected Trains of Emotions.

Opinions of Dr Gerard, Blair, &c. We need say nothing in this place of the opinions expressed on the subject of Beauty by Dr Gerard, Dr Blair, and a whole herd of rhetoricians, because none of them pretend to have any new or original notions with regard to it, and, in general, have been at no pains to reconcile or render consistent the various accounts of the matter, which they have contented themselves with assembling and laying before their readers altogether, as affording among them the best explanation that could be offered of the question. Thus they do not scruple to say, that the sense of Beauty is sometimes produced by the mere organic affection of the senses of sight or hearing; at other times, by a perception of a kind of regular variety; and in other instances by the association of interesting conceptions;—thus abandoning altogether any attempt to answer the radical question,—how the feeling of Beauty should be excited by such opposite causes,—and confounding together, without any attempt at discrimination, those theories which imply the existence of a separate sense or faculty, and those which resolve our sense of Beauty into other more simple or familiar emotions.

Later and more important Speculations. Of late years, however, we have had three publications on the subject of a far higher character,—we mean, Mr Alison's *Essays on the Nature and Principles of Taste*—Mr Payne Knight's *Analytical Inquiry* into the same subjects—and Mr Dugald Stewart's *Dissertations on the Beautiful*, and on *Taste*, in his volume of *Philosophical Essays*. All these works possess an infinite deal of merit, and have among them disclosed almost all the truth that is to be known on the subject; though, as it seems to us, with some little admixture of error, from which it will not, however, be difficult to separate it.

Mr Alison's Theory, that all the Beauty of Material Objects is to be referred to Association.

Mr Alison maintains, that all Beauty, or at least that all the Beauty of material objects, depends on the associations that may have connected them with

It likewise occurs to us to observe, that if every thing was beautiful, which was the occasion of a train of ideas of emotion, it is not easy to see why objects that are called ugly should not be entitled to that appellation. If they are sufficiently ugly not to be viewed with indifference, they too will give rise to ideas of emotion, and those ideas are just as likely to run into trains and series, as those of a more agreeable description. Nay, as contrast itself is one of the principles of association, it is not at all unlikely, that, in the train of impressive ideas which the sight of ugly objects may excite, a transition may be ultimately made to such as are connected with pleasure; and, therefore, if the perception of the Beauty of the object which first suggested them depended upon its having produced a series of ideas of emotion, or even of agreeable emotions, there seems to be no good reason for doubting, that ugly objects may thus be as Beautiful as any other, and that Beauty and Ugliness may be one and the same thing. Such is the danger, as it appears to us, of deserting the ob-

Beauty. **ject itself, or going beyond its immediate effect and impression, in order to discover the sources of its Beauty. Our view of the matter is safer, we think, and far more simple. We conceive the object to be associated either in our past experience, or by some universal analogy, with pleasures, or emotions that upon the whole are pleasant; and that these associated pleasures are instantaneously suggested, as soon as the object is presented, and by the first glimpse of its physical properties, with which, indeed, they are consubstantiated and confounded in our sensations.**

Mr Knight admits association as the chief ingredient of Beauty. The work of Mr Knight is more lively, various, and discursive, than Mr Alison's—but not so systematic or conclusive. It is the cleverer book of the two,—but not the most philosophical discussion of the subject. He agrees with Mr Alison in holding the most important, and, indeed, the only considerable part of Beauty, to depend upon Association, and has illustrated this opinion with a great variety of just and original observation. But he maintains, and maintains stoutly, that there is a Beauty independent of association—prior to it, and more original and fundamental—the primitive and natural Beauty of Colours and Sounds. Now, this we look upon to be a heresy, and a heresy inconsistent with the very first principles of Catholic philosophy. We shall not stop at present to give our reasons for this opinion, which we shall illustrate at large before we bring this article to a close;—but we beg leave merely to suggest at present, that if our sense of Beauty be confessedly in most cases the mere image or reflection of pleasures or emotions that have been associated with objects in themselves indifferent, it cannot fail to appear strange that it should also on some few occasions be a mere organic or sensual gratification of the particular organs. Language, it is believed, affords no other example of so whimsical a combination of different objects under one appellation, or of the confounding of a direct physical sensation with the suggestion of a social or sympathetic moral feeling. We would observe also, that while Mr Knight stickles so violently for this alloy of the senses in the constitution of Beauty, he admits, unequivocally, that Sublimity is, in every instance, and in all cases, the effect of association alone. Yet Sublimity and Beauty, in any just or large sense, and with a view to the philosophy of either, are manifestly one and the same; nor is it conceivable to us, that, if Sublimity be *always* the result of an association with ideas of Power or Danger, Beauty can possibly be, in any case, the result of a mere pleasurable impulse on the nerves of the eye or the ear. We shall return, however, to this discussion hereafter. Of Mr Knight we have only further to observe, that we think he is not less heretical in maintaining, that we have no pleasure in sympathizing with distress or suffering, but only with mental energy; and that, in contemplating the Sublime, we are moved only with a sense of power and grandeur, and never with any feeling of terror or awe.—These errors, however, are less intimately connected with the subject of our present discussion.

But maintains that there is a primitive and independent Beauty in Colours and Sounds.

Mr Stewart's Essay on the Beautiful, chiefly philosophical.

With Mr Stewart we have less occasion for quarrel; chiefly, perhaps, because he has made fewer positive assertions, and entered less into the matter

of controversy. His *Essay on the Beautiful* is rather philological than metaphysical. The object of it is to show by what gradual and successive extensions of meaning the word, though at first appropriated to denote the pleasing effect of *colours* alone, might naturally come to signify all the other pleasing things to which it is now applied. In this investigation he makes many admirable remarks, and touches, with the hand of a master, upon many of the disputable parts of the question; but he evades the particular point at issue between us and Mr Knight, by stating, that it is quite immaterial to his purpose, whether the Beauty of colours be supposed to depend on their organic effect on the eye, or on some association between them and other agreeable emotions,—it being enough for his purpose that this was probably the first sort of Beauty that was observed, and that to which the name was at first exclusively applied. It is evident to us, however, that he leans to the opinion of Mr Knight, as to this Beauty being truly sensual or organic. In observing, too, that Beauty is not now the name of any one thing or quality, but of very many different qualities,—and that it is applied to them all, merely because they are often united in the same objects, or perceived at the same time and by the same organs,—it appears to us that he carries his philology a little too far, and disregards other principles of reasoning of far higher authority. To give the name of Beauty, for example, to every thing that interests or pleases us through the channel of sight, including in this category the mere impulse of light that is pleasant to the organ, and the presentment of objects whose whole charm consists in awakening the memory of social emotions, seems to us to be confounding things together that must always be separate in our feelings, and giving a far greater importance to the mere identity of the organ of perception, than is warranted either by the ordinary language or ordinary experience of men. Upon the same principle we should give this name of Beautiful, and no other, to all acts of kindness or magnanimity, and, indeed, to every interesting occurrence which took place in our sight, or came to our knowledge by means of the eye:—nay, as the ear is also allowed to be a channel for impressions of Beauty, the same name should be given to any interesting or pleasant thing that we hear,—and good news read to us from the gazette should be denominated Beautiful, just as much as a fine composition of music. These things, however, are never called Beautiful, and are felt, indeed, to afford a gratification of quite a different nature. It is no doubt true, as Mr Stewart has observed, that Beauty is not one thing, but many,—and does not produce one uniform emotion, but an infinite variety of emotions. But this we conceive is not merely because many pleasant things may be intimated to us by the same sense, but because the things that are called Beautiful may be associated with an infinite variety of agreeable emotions, of the specific character of which their Beauty will consequently partake. Nor does it follow, from the fact of this great variety, that there can be no other principle of union among these agreeable emotions, but that of a *name*, extended to them all upon the very slight ground of their

Beauty.

Questionable Doctrine as to the extension of the name of Beautiful to pleasing Objects that address themselves to the same Sense.

Beauty. coming through the same organ; since, upon our theory, and indeed upon Mr Stewart's, in a vast majority of instances, there is the remarkable circumstance of their being all *suggested* by association with some present sensation, and all modified and compounded to our feelings by an actual and direct perception.

It is unnecessary, however, to pursue these criticisms, or, indeed, this hasty review of the speculation of other writers, any farther. The few observations we have already made, will enable the intelligent reader, both to understand in a general way what has been already done on the subject, and in some degree prepare him to appreciate the merits of that theory, substantially the same with Mr Alison's, which we shall now proceed to illustrate somewhat more in detail.

Farther Illustration of the Theory of Associations.

The basis of it is, that the Beauty which we impute to outward objects, is nothing more than the reflection of our own inward emotions, and is made up entirely of certain little portions of love, pity, and affection, which have been connected with these objects, and still adhere as it were to them, and move us anew whenever they are presented to our observation. Before proceeding to bring any proof of the truth of this proposition, there are two things that it may be proper to explain a little more distinctly. First, * What are the primary affections, by the suggestion of which we think the sense of Beauty is produced? And, secondly, What is the nature of the connexion by which we suppose that the objects we call beautiful are enabled to suggest these affections?

What Affections may be the basis of Beauty.

With regard to the first of these points, it fortunately is not necessary either to enter into any tedious details, or to have recourse to any nice distinctions. All sensations that are not absolutely indifferent, and are, at the same time, either agreeable, when experienced by ourselves, or attractive when contemplated in others, may form the foundation of the emotions of Sublimity or Beauty. The love of sensation seems to be the ruling appetite of human nature; and many sensations, in which the painful seems to bear no little share, are consequently sought for with avidity, and recollected with interest, even in our own persons. In the persons of others, emotions still more painful are contemplated with eagerness and delight; and therefore we must not be surprised to find, that many of the pleasing sensations of Beauty or Sublimity resolve themselves ultimately into recollections of feelings that may appear to have a very opposite character. The sum of the whole is, that every feeling which it is agreeable to experience, to recal, or to witness, may become the source of beauty in external objects, when it is so connected with them as that their appearance reminds us of that feeling. Now, in real life, and from daily experience and observation, we know that it is agreeable, in the first place, to recollect our own pleasurable sensations, or to be enabled to form a lively

conception of the pleasures of other men, or even of sentient beings of any description. We know likewise, from the same sure authority, that there is a certain delight in the remembrance of our past, or the conception of our future emotions, even though attended with great pain, provided they be not forced too rudely on the mind, and be softened by the accompaniment of any milder feeling. And finally, we know, in the same manner, that the spectacle or conception of the emotions of others, even when in a high degree painful, is extremely interesting and attractive, and draws us away, not only from the consideration of indifferent objects, but even from the pursuit of light or frivolous enjoyments. All these are plain and familiar facts, of the existence of which, however they may be explained, no one can entertain the slightest doubt,—and into which, therefore, we shall have made no inconsiderable progress, if we can resolve the more mysterious fact, of the emotions we receive from the contemplation of Sublimity or Beauty.

Beauty.

Our proposition then is, that these emotions are not original emotions, nor produced directly by any qualities in the objects which excite them; but are reflections, or images, of the more radical and familiar emotions to which we have already alluded; and are occasioned, not by any inherent virtue in the objects before us, but by the accidents, if we may so express ourselves, by which these may have been enabled to suggest or recal to us our own past sensations or sympathies. We might almost venture, indeed, to lay it down as an axiom, that, except in the plain and palpable case of bodily pain or pleasure, we can never be *interested* in any thing but the fortunes of sentient beings;—and that every thing partaking of the nature of mental emotion, must have for its object the feelings, past, present or possible, of something capable of sensation. Independent, therefore, of all evidence, and without the help of any explanation, we should have been apt to conclude, that the emotions of Beauty and Sublimity must have for their objects the sufferings or enjoyments of sentient beings;—and to reject, as intrinsically absurd and incredible, the supposition, that material objects, which obviously do neither hurt nor delight the body, should yet excite, by their mere physical qualities, the very powerful emotions which are sometimes excited by the spectacle of Beauty.

Of the feelings, by their connexion with which external objects become beautiful, we do not think it necessary to speak more minutely;—and, therefore, it only remains, under this preliminary view of the subject, to explain the nature of that connexion by which we conceive this effect to be produced. Here, also, there is but little need for minuteness, or fulness of enumeration. Almost every tie, by which two objects can be bound together in the imagination, in such a manner as that the presentment of the one shall recal the memory of the other;—or, in

Nature of the associations by which objects appear Beautiful.

* A considerable part of the sequel of this article has already appeared in a critique (by the same author) upon Mr Alison's *Essay* in the *Edinburgh Review* for May 1811.

Beauty.

other words, almost every possible relation which can subsist between such objects, may serve to connect the things we call Sublime or Beautiful, with feelings that are interesting or delightful. It may be useful, however, to class these bonds of association between Mind and Matter in a rude and general way.

It appears to us, then, that objects are Sublime or Beautiful, *First*, When they are the Natural signs, and Perpetual concomitants of pleasurable sensations, or, at any rate, of some lively feeling or emotion in ourselves or in some other sentient beings; or, *Secondly*, When they are the arbitrary or Accidental concomitants of such feelings; or, *Thirdly*, When they bear some Analogy or fanciful resemblance to things with which these emotions are necessarily connected. In endeavouring to illustrate the nature of these several relations, we shall be led to lay before our readers some proofs that appear to us satisfactory of the truth of the general theory.

First Class of Associations, where the external object is necessarily connected with the emotion.

The most obvious, and the strongest association that can be established between inward feelings and external objects is, where the object is Necessarily and Universally connected with the feeling by the law of nature, so that it is always presented to the senses when the feeling is impressed upon the mind,—as the sight or the sound of laughter, with the feeling of gaiety,—of weeping with distress,—of the sound of thunder, with ideas of danger and power. Let us dwell for a moment on the last instance.—Nothing, perhaps, in the whole range of nature, is more strikingly and universally sublime than the sound we have just mentioned; yet it seems obvious, that the sense of sublimity is produced, not by any quality that is perceived by the ear, but altogether by the impression of Power and of Danger that is necessarily made upon the mind, whenever that sound is heard. That it is not produced by any peculiarity in the sound itself, is certain, from the mistakes that are frequently made with regard to it. The noise of a cart rattling over the stones, is often mistaken for thunder; and as long as the mistake lasts, this very vulgar and insignificant noise is actually felt to be prodigiously sublime. It is so felt, however, it is perfectly plain, merely because it is then associated with ideas of prodigious power and undefined danger;—and the sublimity is destroyed, the moment the association is dissolved, though the sound itself, and its effect on the organ, continue exactly the same. This, therefore, is an instance in which sublimity is distinctly proved to consist, not in any physical quality of the object to which it is ascribed, but in its necessary connexion with that vast and uncontrolled Power which is the natural object of awe and veneration.

Other Examples. Beauty of the Human Countenance.

We may now take an example a little less plain and elementary. The most beautiful object in nature, perhaps, is the countenance of a young and beautiful woman;—and we are apt at first to imagine, that, independent of all associations, the forms and colours which it displays are, in themselves, lovely and engaging, and would appear charming to all beholders, with whatever other qualities or impressions they might happen to be connected. A very little reflection, however, will probably be sufficient to convince us of the fallacy of this impression; and to satisfy us, that what we admire is not a combination of

Beauty.

forms and colours, which could never excite any mental emotion, but a collection of signs and tokens of certain mental feelings and affections, which are universally recognised as the proper objects of love and sympathy. Laying aside the emotions arising from difference of sex, and supposing female beauty to be contemplated by the pure and unenvying eye of a female, it seems quite obvious, that, among its ingredients, we should trace the signs of two different sets of qualities, that are neither of them the object of sight, but of a higher faculty;—in the first place, of youth and health; and in the second place, of innocence, gaiety, sensibility, intelligence, delicacy or vivacity. Now, without enlarging upon the natural effect of these suggestions, we shall just suppose that the appearances, which must be admitted at all events to be actually significant of the qualities we have enumerated, had been by the law of nature attached to the very opposite qualities;—that the smooth forehead, the firm cheek, and the full lip, which are now so distinctly expressive to us of the gay and vigorous periods of youth,—and the clear and blooming complexion, which indicates health and activity, had been in fact the forms and colours by which old age and sickness were characterized; and that, instead of being found united to those sources and seasons of enjoyment, they had been the badges by which nature pointed out that state of suffering and decay which is now signified to us by the livid and emaciated face of sickness, or the wrinkled front, the quivering lip, and hollow cheek of age;—If this were the familiar law of our nature, can it be doubted that we should look upon these appearances, not with rapture, but with aversion,—and consider it as absolutely ludicrous or disgusting, to speak of the beauty of what was interpreted by every one as the lamented sign of pain and decrepitude? Mr Knight himself, though a firm believer in the intrinsic beauty of colours, is so much of this opinion, that he thinks it entirely owing to those associations that we prefer the tame smoothness, and comparatively poor colours of a youthful face, to the richly fretted and variegated countenance of a pimpled drunkard.

Such, we conceive, would be the inevitable effect of dissolving the subsisting connexion between the animating ideas of hope and enjoyment, and those visible appearances which are now significant of those emotions, and derive their whole Beauty from that signification. But the effect would be still stronger, if we could suppose the *moral* expression of those appearances to be reversed in the same manner. If the smile, which now enchants us, as the expression of innocence and affection, were the sign attached by nature to guilt and malignity,—if the blush which expresses delicacy, and the glance that speaks intelligence, vivacity and softness, had always been found united with brutal passion or idiot moodiness; is it not certain, that the whole of their Beauty would be extinguished, and that our emotions from the sight of them would be exactly the reverse of what they now are?

That the Beauty of a living and sentient creature should depend, in a great degree, upon qualities peculiar to such a creature, rather than upon the mere

Beauty. physical attributes which it may possess in common with the inert matter around it, cannot indeed appear a very improbable supposition to any one. But it may be more difficult for some persons to understand how the beauty of mere dead matter should be derived from the feelings and sympathies of sentient beings. It is absolutely necessary, therefore, that we should give an instance or two of this derivation.

Of the Beauty of inanimate Objects, and the Associations on which it depends—Beauty of Land-scapes.

It is easy enough to understand how the sight of a picture or statue should affect us nearly in the same way as the sight of the original: nor is it much more difficult to conceive, how the sight of a cottage should give us something of the same feeling as the sight of a peasant's family; and the aspect of a town raise many of the same ideas as the appearance of a multitude of persons. We may begin, therefore, with an example a little more complicated. Take, for instance, the case of a common English landscape—green meadows with fat cattle—canals or navigable rivers—well fenced, well cultivated fields—neat, clean, scattered cottages—humble antique church, with church yard elms, and crossing hedges—all seen under bright skies, and in good weather:—There is much Beauty, as every one will acknowledge, in such a scene. But in what does the Beauty consist? Not certainly in the mere mixture of colours and forms; for colours more pleasing, and lines more graceful (according to any theory of grace that may be preferred), might be spread upon a board, or a painter's pallet, without engaging the eye to a second glance, or raising the least emotion in the mind;—but in the picture of human happiness that is presented to our imaginations and affections,—in the visible and unequivocal signs of comfort, and cheerful and peaceful enjoyment,—and of that secure and successful industry that ensures its continuance,—and of the piety by which it is exalted,—and of the simplicity by which it is contrasted with the guilt and the fever of a city life;—in the images of health and temperance and plenty which it exhibits to every eye,—and in the glimpses which it affords to warmer imaginations, of those primitive or fabulous times, when man was uncorrupted by luxury and ambition, and of those humble retreats in which we still delight to imagine that love and philosophy may find an unpolluted asylum. At all events, however, it is human feeling that excites our sympathy, and forms the object of our emotions. It is man, and man alone, that we see in the beauties of the earth which he inhabits;—or, if a more sensitive and extended sympathy connect us with the lower families of animated nature, and make us rejoice with the lambs that bleat on the uplands, or the cattle that ruminates in the valley, or even with the living plants that drink the bright sun and the balmy air beside them, it is still the idea of enjoyment—of feelings that animate the existence of sentient beings—that calls forth all our emotions, and is the parent of all the Beauty with which we proceed to invest the inanimate creation around us.

Instead of this quiet and tame *English* landscape, let us now take a Welch or a Highland scene; and see whether its beauties will admit of being explained

on the same principle. Here, we shall have lofty mountains, and rocky and lonely recesses,—tufted woods hung over precipices,—lakes intersected with castled promontories,—ample solitudes of unploughed and untrodden valleys,—nameless and gigantic ruins,—and mountain echoes repeating the scream of the eagle and the roar of the cataract. This, too, is beautiful;—and, to those who can interpret the language it speaks, far more beautiful than the prosperous scene with which we have contrasted it. Yet, lonely as it is, it is to the recollection of man and of human feelings that its Beauty also is owing. The mere forms and colours that compose its visible appearance, are no more capable of exciting any emotion in the mind, than the forms and colours of a Turkey carpet. It is sympathy with the present or the past, or the imaginary *inhabitants* of such a region, that alone gives it either interest or Beauty; and the delight of those who behold it, will always be found to be in exact proportion to the force of their imaginations, and the warmth of their social affections. The leading impressions, here, are those of romantic seclusion, and primeval simplicity; lovers sequestered in these blissful solitudes, “from towns and toils remote,”—and rustic poets and philosophers communing with nature, at a distance from the low pursuits and selfish malignity of ordinary mortals;—then there is the sublime impression of the Mighty Power which piled the massive cliffs upon each other, and rent the mountains asunder, and scattered their giant fragments at their base;—and all the images connected with the monuments of ancient magnificence and extinguished hostility,—the feuds, and the combats, and the triumphs of its wild and primitive inhabitants, contrasted with the stillness and desolation of the scenes where they lie interred;—and the romantic ideas attached to their ancient traditions, and the peculiarities of their present life,—their wild and enthusiastic poetry,—their gloomy superstitions,—their attachment to their chiefs,—the dangers, and the hardships and enjoyments of their lonely huntings and fishings,—their pastoral shielings on the mountains in summer,—and the tales and the sports that amuse the little groups that are frozen into their vast and trackless valleys in the winter. Add to all this, the traces of vast and obscure antiquity that are impressed on the language and the habits of the people, and on the cliffs, and caves, and gulfy torrents of the land; and the solemn and touching reflection, perpetually recurring, of the weakness and insignificance of perishable man, whose generations thus pass away into oblivion, with all their toils and ambition, while Nature holds on her unvarying course, and pours out her streams, and renews her forests, with undecaying activity, regardless of the fate of her proud and perishable sovereign.

We have said enough, we believe, to let our readers understand what we mean by external objects being the natural signs or concomitants of human sympathies or emotions. Yet we cannot refrain from adding one other illustration, and asking on what other principle we can account for the beauty of Spring? Winter has shades as deep, and colours as brilliant; and the great forms of nature are substan-

Beauty.

Beauty. tially the same through all the revolutions of the year. We shall seek in vain, therefore, in the accidents of mere organic matter, for the sources of that " vernal delight and joy," which subject all finer spirits to an annual intoxication, and strike home the sense of Beauty even to hearts that seem proof against it under all other aspects. And it is not among the Dead but among the Living, that this Beauty originates. It is the renovation of life and of joy to all animated beings, that constitutes this great jubilee of nature;—the young of animals bursting into existence,—the simple and universal pleasures which are diffused by the mere temperature of the air, and the profusion of sustenance,—the pairing of birds,—the cheerful resumption of rustic toils,—the great alleviation of all the miseries of poverty and sickness,—our sympathy with the young life, and the promise and the hazards of the vegetable creation,—the solemn, yet cheering, impression of the constancy of Nature to her great periods of renovation,—and the hopes that dart spontaneously forward into the new circle of exertions and enjoyments that is opened up by her hand and her example. Such are some of the conceptions that are forced upon us by the appearances of returning Spring; and that seem to account for the emotions of delight with which these appearances are hailed, by every mind endowed with any degree of sensibility, somewhat better than the brightness of the colours, or the agreeableness of the smells that are then presented to our senses.

Of Childhood.

They are kindred conceptions that constitute all the beauty of Childhood. The forms and colours that are peculiar to that age, are not necessarily or absolutely beautiful in themselves; for, in a grown person, the same forms and colours would be either ludicrous or disgusting. It is their indestructible connexion with the engaging ideas of innocence,—of careless gaiety,—of unsuspecting confidence;—made still more tender and attractive by the recollection of helplessness, and blameless and happy ignorance,—of the anxious affection that watches over all their ways,—and of the hopes and fears that seek to pierce futurity, for those who have neither fears nor cares nor anxieties for themselves.

These few illustrations will probably be sufficient to give our readers a general conception of the character and the grounds of that theory of beauty which we think affords the only true or consistent account of its nature. They are all examples, it will be observed, of the *First* and most important connexion which we think may be established between external objects and the sentiments or emotions of the mind; or cases, in which the visible phenomena are the Natural and Universal accompaniments of the emotion, and are consequently capable of reviving that emotion, in some degree, in the breast of every beholder. If the tenor of those illustrations has been such as to make any impression in favour of the general theory, we conceive that it must be very greatly confirmed by the slightest consideration of the *Second* class of cases, or those in which the external object is not the natural and necessary, but only the occasional or accidental concomitant of the emotion which it recalls. In the former instances,

Second Class of Associations,—where the Beauty is derived from Associations not universal.

some conception of beauty seems to be inseparable from the appearance of the objects; and being impressed, in some degree, upon all persons to whom they are presented, there is evidently room for insinuating that it is an independent and intrinsic quality of their nature, and does not arise from association with any thing else. In the instances, however, to which we are now to allude, this perception of Beauty is not universal, but entirely dependent upon the opportunities which each individual has had to associate ideas of emotion with the object to which it is ascribed;—the same thing appearing Beautiful to those who have been exposed to the influence of such associations, and indifferent to those who have not. Such instances, therefore, really afford an *experimentum crucis* as to the truth of the theory in question; nor is it easy to conceive any more complete evidence, both that there is no such thing as absolute or intrinsic Beauty, and that it depends altogether on those associations with which it is thus found to come and to disappear.

The accidental or arbitrary relations that may thus be established between natural sympathies or emotions, and external objects, may be either such as occur to whole classes of men, or are confined to particular individuals. Among the former, those that apply to different nations or races of men, are the most important and remarkable; and constitute the basis of those peculiarities by which National Tastes are distinguished. Take, again, for example, the instance of female Beauty,—and think what different and inconsistent standards would be fixed for it in the different regions of the world;—in Africa, in Asia, and in Europe;—in Tartary and in Greece; in Lapland, Patagonia and Circassia. If there was any thing absolutely or intrinsically Beautiful, in any of the forms thus distinguished, it is inconceivable that men should differ so outrageously in their conceptions of it: If Beauty were a real and independent quality, it seems impossible that it should be distinctly and clearly felt by one set of persons, where another set, altogether as sensitive, could see nothing but its opposite; and if it were actually and inseparably attached to certain forms, colours, or proportions, it must appear utterly inexplicable that it should be felt and perceived in the most opposite forms and proportion, in objects of the same description. On the other hand, if all Beauty consist in reminding us of certain natural sympathies and objects of emotion, with which they have been habitually connected, it is easy to perceive how the most different forms should be felt to be equally Beautiful. If female Beauty, for instance, consist in the visible signs and expressions of youth and health, and of gentleness, vivacity, and kindness; then it will necessarily happen, that the forms, and colours and proportions which nature may have connected with those qualities, in the different climates or regions of the world, will all appear equally Beautiful to those who have been accustomed to recognise them as the signs of such qualities; while they will be respectively indifferent to those who have not learned to interpret them in this sense, and displeasing to those whom experience has led to consider them as the signs of opposite qualities. The case is

Beauty. the same, though perhaps to a smaller degree, as to the peculiarity of National Taste in other particulars. The style of dress and architecture in every nation, if not adopted from mere want of skill, or penury of materials, always appears Beautiful to the natives, and somewhat monstrous and absurd to foreigners ;— and the general character and aspect of their landscape, in like manner, if not associated with substantial evils and inconveniencies, always appears more beautiful and enchanting than the scenery of any other region. The fact is still more striking, perhaps, in the case of Music ;—in the effects of those national airs, with which even the most uncultivated imaginations have connected so many interesting recollections ; and in the delight with which all persons of sensibility catch the strains of their native melodies in strange or in distant lands. It is owing chiefly to the same sort of arbitrary and national association, that white is thought a gay colour in Europe, where it is used at weddings,—and a dismal colour in China, where it is used for mourning ;— that we think yew-trees gloomy, because they are planted in churchyards,—and large masses of powdered horsehair majestic, because we see them on the heads of judges and bishops.

Effects of Education on Taste, another.

Next to those curious instances of arbitrary or limited associations that are exemplified in the diversities of National taste, are those that are produced by the differences of instruction or Education. If external objects were sublime or beautiful in themselves, it is plain, that they would appear equally so to those who were acquainted with their origin, and to those to whom it was unknown. Yet it is not easy, perhaps, to calculate the degree to which our notions of Beauty and Sublimity are now influenced, over all Europe, by the study of Classical literature ; or the number of impressions of this sort which the well-educated consequently receive, from objects that are utterly indifferent to uninstructed persons of the same natural sensibility. We gladly avail ourselves, upon this subject, of the beautiful expressions of Mr Alison.

“ The delight which most men of education receive from the consideration of antiquity, and the beauty that they discover in every object which is connected with ancient times, is in a great measure to be ascribed to the same cause. The antiquarian, in his cabinet, surrounded by the relics of former ages, seems to himself to be removed to periods that are long since past, and indulges in the imagination of living in a world, which, by a very natural kind of prejudice, we are always willing to believe was both wiser and better than the present. All that is venerable or laudable in the history of these times, present themselves to his memory. The gallantry, the heroism, the patriotism of antiquity, rise again before his view, softened by the obscurity in which they are involved, and rendered more seducing to the imagination by that obscurity itself, which, while it mingles a sentiment of regret amid his pursuits, serves at the same time to stimulate his fancy to fill up, by its own creation, those long intervals of time of which history has preserved no record. The relics he contemplates, seem to approach him still nearer to the ages of his regard. The dress, the furniture, the

VOL. II. PART I.

Beauty. arms of the times, are so many assistances to his imagination, in guiding or directing its exercise ; and, offering him a thousand sources of imagery, provide him with an almost inexhaustible field in which his memory and his fancy may expatiate. There are few men who have not felt somewhat, at least, of the delight of such an employment. There is no man in the least acquainted with the history of antiquity, who does not love to let his imagination loose on the prospect of its remains, and to whom they are not in some measure sacred, from the innumerable images which they bring. Even the peasant, whose knowledge of former times extends but to a few generations, has yet in his village some monument of the deeds or virtues of his forefathers ; and cherishes, with a fond veneration, the memorial of those good old times to which his imagination returns with delight, and of which he loves to recount the simple tales that tradition has brought him.

“ And what is it that constitutes that emotion of sublime delight, which every man of common sensibility feels upon the first prospect of Rome ? It is not the scene of destruction which is before him. It is not the Tiber, diminished in his imagination to a paltry stream, flowing amid the ruins of that magnificence which it once adorned. It is not the triumph of superstition over the wreck of human greatness, and its monuments erected upon the very spot where the first honours of humanity have been gained. It is ancient Rome which fills his imagination. It is the country of Cæsar, and Cicero, and Virgil, which is before him. It is the mistress of the world which he sees, and who seems to him to rise again from her tomb, to give laws to the universe. All that the labours of his youth, or the studies of his maturer age have acquired, with regard to the history of this great people, open at once before his imagination, and present him with a field of high and solemn imagery, which can never be exhausted. Take from him these associations,—conceal from him that it is Rome that he sees, and how different would be his emotion !”

The influences of the same studies may be traced, indeed, through almost all our impressions of Beauty,—and especially in the feelings which we receive from the contemplation of rural scenery ; where the images and recollections which have been associated with such objects, in the enchanting strains of the poets, are perpetually recalled by their appearance, and give an interest and a Beauty to the prospect, of which the uninstructed cannot have the slightest perception. Upon this subject, also, Mr Alison has expressed himself with his usual warmth and elegance. After observing, that, in childhood, the Beauties of nature have scarcely any existence for those who have as yet but little general sympathy with mankind, he proceeds to state, that they are usually first recommended to notice by the poets, to whom we are introduced in the course of education ; and who, in a manner, create them for us, by the associations which they enable us to form with their visible appearance.

“ How different, from this period, become the sentiments with which the scenery of nature is contemplated, by those who have any imagination !

A A

Beauty. The beautiful forms of ancient mythology, with which the fancy of poets peopled every element, are now ready to appear to their minds, upon the prospect of every scene. The descriptions of ancient authors, so long admired, and so deserving of admiration, occur to them at every moment, and with them, all those enthusiastic ideas of ancient genius and glory, which the study of so many years of youth so naturally leads them to form. Or, if the study of modern poetry has succeeded to that of the ancient, a thousand other beautiful associations are acquired, which, instead of destroying, serve easily to unite with the former, and to afford a new source of delight. The awful forms of Gothic superstition, the wild and romantic imagery, which the turbulence of the middle ages, the Crusades, and the institution of Chivalry have spread over every country of Europe, arise to the imagination in every scene; accompanied with all those pleasing recollections of prowess, and adventure, and courteous manners, which distinguished those memorable times. With such images in their minds, it is not common nature that appears to surround them. It is nature embellished and made sacred by the memory of Theocritus and Virgil, and Milton and Tasso; their genius seems still to linger among the scenes which inspired it, and to irradiate every object where it dwells; and the creation of their fancy seem the fit inhabitants of that nature, which their descriptions have clothed with beauty."

Other Effects.

It is needless, for the purpose of mere illustration, to pursue this subject of arbitrary or accidental association though all the divisions of which it is susceptible; and, indeed, the task would be endless; since there is scarcely any class in society which could not be shown to have peculiar associations of interest and emotion with objects which are not so connected in the minds of any other class. The young and the old—the rich and the poor—the artist and the man of science—the inhabitant of the city and the inhabitant of the country—the man of business and the man of pleasure—the domestic and the dissipated,—nay, even the followers of almost every different study or profession, have perceptions of beauty, because they have associations with external objects, that are peculiar to themselves, and have no existence for any other persons. But, though the detail of such instances could not fail to show, in the clearest and most convincing manner, how directly the notion of beauty is derived from some more radical and familiar emotion, and how many and various are the channels by which such emotions are transmitted, enough, perhaps, has been already said, to put our readers in possession of the principles and general bearings of an argument which we must not think of exhausting.

The Effect of Fashion on our Opinion of the Beauty of Dress.

Before entirely leaving this branch of the subject, however, let us pause for a moment on the familiar but very striking and decisive instance of our varying and contradictory judgments, as to the Beauty of the successive fashions of dress that have existed within our own remembrance. All persons who still continue to find amusement in society, and are not old enough to enjoy only the recollections of their youth, think the prevailing fashions becoming and grace-

Beauty. ful, and the fashions of twenty or twenty-five years old intolerably ugly and ridiculous. The younger they are, and the more they mix in society, this impression is the stronger; and the fact is worth noticing, because there is really no one thing as to which persons judging merely from their feelings, and therefore less likely to be misled by any systems or theories, are so very positive and decided, as that established fashions are Beautiful in themselves; and that exploded fashions are intrinsically and beyond all question preposterous and ugly. We have never yet met a young lady or gentleman, who spoke from their hearts and without reserve, who had the least doubt on the subject, or could conceive how any person could be so stupid as not to see the intrinsic elegance of the reigning mode, or not to be struck with the ludicrous awkwardness of the habits in which their mothers were disguised. Yet there can be no doubt, that if these ingenious critics had been born, with the same natural sensibility to Beauty, but twenty years earlier, they would have joined in admiring what they now laugh at, as certainly as those who succeed them twenty years hereafter will laugh at them. It is plain, then, and we think scarcely disputed, out of the circles to which we have alluded, that there is, in the general case, no intrinsic Beauty or deformity in any of those fashions; and that the forms, and colours, and materials, that are, we may say, universally and very strongly felt to be Beautiful while they are in fashion, are sure to lose all their Beauty as soon as the fashion has passed away. Now the forms, and colours, and combinations, remain exactly as they were; and, therefore, it seems perfectly obvious, that the source of their successive Beauty and ugliness must be sought in something extrinsic, and can only be found in the associations which once recommended and ultimately degraded them in our estimation. While they were in fashion, they were the forms and colours which distinguished the rich and the noble,—the eminent, the envied, the observed in society. They were the forms and the colours in which all that was beautiful, and admired, and exalted, were habitually arrayed. They were associated, therefore, with ideas of opulence, and elegance, and gaiety, and all that is captivating and bewitching, in manners, fortune, and situation,—and derived the whole of their Beauty from those associations. By and bye, however, they were deserted by the beautiful, the rich, and the elegant, and descended to the vulgar and dependent, or were only seen in combination with the antiquated airs of faded beauties or obsolete beaux. They thus came to be associated with ideas of vulgarity and derision, and with the images of old and decayed persons, whom it is difficult for their juniors to believe ever to have been young or attractive;—and the associations being thus reversed, in which all their Beauty consisted, the Beauty itself naturally disappears.

The operation of the same causes is distinctly visible in all the other apparent irregularities of our judgments as to this description of Beauty. Old people have in general but little toleration for the obsolete fashions of their later or middle years; but will generally stickle for the intrinsic elegance of

Beauty. those which were prevalent in the bright days of their early youth,—as being still associated in their recollections, with the beauty with which they were first enchanted, and the gay spirits with which they were then inspired. In the same way, while we laugh at the fashions of which fine ladies and gentlemen were proud in the days of our childhood, because they are now associated only with images of decrepitude and decay, we look with some feelings of veneration on the habits of more remote generations, the individuals of which are only known to us as historical persons; and with unmingled respect and admiration on those still more ancient habiliments which remind us either of the heroism of the feudal chivalry, or the virtue and nobleness of classical antiquity. The iron mail of the Gothic knight, or the clumsy shield and naked arms of the Roman warrior, strike us as majestic and graceful, merely because they are associated with nothing but tales of romantic daring or patriotic prowess,—while the full bottomed periwigs that were added to the soldier's equipment in the days of Lewis XIV. and King William,—and no doubt had a noble effect in the eyes of that generation,—now appear to us equally ridiculous and unbecoming, merely because such appendages are no longer to be seen, but upon the heads of sober and sedentary lawyers, or in the pictures of antiquated Esquires.

Associa-
tions pe-
culiar to
Individuals
—their Ef-
fects.

We cannot afford, however, to enlarge any farther upon these considerations,—and are inclined indeed to think, that what has been already said on the subject of associations, which, though not universal, are common to whole classes of persons, will make it unnecessary to enlarge on those that are peculiar to each individual. It is almost enough, indeed, to transcribe the following short passage from Mr Alison.

“ There is no man, who has not some interesting associations with particular scenes, or airs, or books, and who does not feel their beauty or sublimity enhanced to him by such connexions. The view of the house where one was born, of the school where one was educated, and where the gay years of infancy were passed, is indifferent to no man. They recall so many images of past happiness and past affections, they are connected with so many strong or valued emotions, and lead altogether to so long a train of feelings and recollections, that there is hardly any scene which one ever beholds with so much rapture. There are songs also, that we have heard in our infancy, which, when brought to our remembrance in after years, raise emotions for which we cannot well account; and which, though perhaps very indifferent in themselves, still continue from this association, and from the variety of conceptions which they kindle in our minds, to be our favourites through life. The scenes which have been distinguished by the residence of any person, whose memory we admire, produce a similar effect. *Movemur enim, nescio quo pacto, locis ipsis, in quibus eorum, quos diligimus, aut admiramur adsunt vestigia.* The scenes themselves may be little beautiful; but the delight with which we recollect the traces of their lives, blends itself insensibly with the emotions which the scenery excites; and the admiration which these recollections afford, seems to give

a kind of sanctity to the place where they dwelt, and converts every thing into Beauty which appears to have been connected with them.”

Beauty.

There are similar impressions,—as to the sort of scenery to which we have been long accustomed,—as to the style of personal beauty by which we were first enchanted,—and even as to the dialect, or the form of versification which we first begun to admire, that bestow a secret and adventitious charm upon all these objects, and enable us to discover in them a Beauty which is invisible, because it is non-existent to every other eye.

In all the cases we have hitherto considered, the external object is supposed to have acquired its Beauty, by being actually connected with the causes of our natural emotions, either as a sign of their existence, or as being locally present to their ordinary occasions. There is a relation, however, of another kind, to which it is necessary to attend, both to elucidate the general grounds of the theory, and to explain several appearances that might otherwise expose it to objections. This is the relation which external objects may bear to our internal feelings, and the power they may consequently acquire of suggesting them, in consequence of a sort of resemblance or analogy which they seem to have to their natural and appropriate objects. The language of poetry is founded, in a great degree, upon this analogy; and all language, indeed, is full of it; and attests, by its structure, both the extent to which it is spontaneously pursued, and the effects that are produced by its suggestion. We take a familiar instance from the elegant writer to whom we have already referred.

Third Class
of Associa-
tions—
those which
depend on
a certain
analogy or
affinity
between
mental
qualities
or emo-
tions and
external
objects.

“ What, for instance, is the impression we feel from the scenery of spring? The soft and gentle green with which the earth is spread, the feeble texture of the plants and flowers, and the remains of winter yet lingering among the woods and hills,—all conspire to infuse into our minds somewhat of that fearful tenderness with which infancy is usually beheld. With such a sentiment, how innumerable are the ideas which present themselves to our imagination! ideas, it is apparent, by no means confined to the scene before our eyes, or to the possible desolation which may yet await its infant beauty, but which almost involuntarily extend themselves to analogies with the life of man, and bring before us all those images of hope or fear, which, according to our peculiar situations, have the dominion of our hearts!—The Beauty of autumn is accompanied with a similar exercise of thought: The leaves begin then to drop from the trees; the flowers and shrubs, with which the fields were adorned in the summer months, decay; the woods and groves are silent; the sun himself seems gradually to withdraw his light, or to become enfeebled in his power. Who is there, who, at this season, does not feel his mind impressed with a sentiment of melancholy? or who is able to resist that current of thought, which, from such appearances of decay, so naturally leads him to the solemn imagination of that inevitable fate, which is to bring on alike the decay of life, of empire, and of nature itself.”

A thousand such analogies, indeed, are suggested

Beauty.
Further
Illustrations.

to us by the most familiar aspects of nature. The morning and the evening present the same ready picture of youth and of closing life, as the various vicissitudes of the year. The withering of flowers images out to us the languor of beauty, or the sickness of childhood. The loud roar of troubled waters seems to bear some resemblance to the voice of lamentation or violence; and the softer murmur of brighter streams, to be expressive of cheerfulness and innocence. The purity and transparency of water or of air, indeed, is itself felt to be expressive of mental purity and gaiety; and their darkness or turbulence, of mental gloom and dejection. The genial warmth of autumn suggests to us the feeling of mild benevolence;—the sunny gleams and fitful showers of early spring, remind us of the waywardness of infancy;—flowers waving on their slender stems, impress us with the notion of flexibility and lightness of temper. All fine and delicate forms are typical of delicacy and gentleness of character; and almost all forms, bounded by waving or flowing lines, suggest ideas of ease, pliability, and elegance. Rapid and impetuous motion seems to be emblematical of violence and passion;—slow and steady motion, of deliberation, dignity, and resolution;—fluttering motion, of inconstancy or terror;—and waving motion, according as it is slow or swift, of sadness or playfulness. A lofty tower or a massive building gives us the idea of firmness and elevation of character;—a rock battered by the waves, of fortitude in adversity. Stillness and calmness in the water or the air, seem to shadow out tenderness, indolence, and placidity;—moonlight we call pensive and gentle;—and the unclouded sun gives us an impression of exulting vigour, and domineering ambition and glory.

Existence of such analogies indisputably proved by the structure of Language in all Countries.

It is not difficult, with the assistance which language affords us, to trace the origin of all these, and a thousand other associations. In many instances, the qualities which thus suggest mental emotions, do actually resemble their constant concomitants in human nature, as is obviously the case with the forms and motions which are sublime or beautiful; and, in some, their effects and relations bear so obvious an analogy to those of human conduct or feeling, as to force itself upon the notice of the most careless beholder. But, whatever may have been their original, the very structure of language attests the vast extent to which they have been carried, and the nature of the suggestions to which they are indebted for their interest or beauty. If we speak familiarly of the sparkling of wit—and the darkness of melancholy—can it be at all difficult to conceive that bright light may be agreeable, because it reminds us of gaiety,—and darkness oppressive, because it is felt to be emblematical of sorrow? It is very remarkable, indeed, that, while almost all the words by which the affections of the mind are expressed, seem to have been borrowed originally from the qualities of matter, the epithets by which we learn afterwards to distinguish such material objects as are felt to be Sublime or Beautiful, are all of them epithets that had been previously appropriated to express some quality or emotion of mind. Colours are said to be gay or grave—motions to be lively, or deliberate, or capricious—forms to be delicate or modest—sounds to be

animated or mournful—prospects to be cheerful or melancholy—rocks to be bold—waters to be tranquil—and a thousand other phrases of the same import; all indicating, most unequivocally, the sources from which our interest in matter is derived, and proving, that it is necessary, in all cases, to confer mind and feeling upon it, before it can be conceived as either sublime or beautiful. The great charm, indeed, and the great secret of poetical diction, consists in thus lending life and emotion to all the objects it embraces; and the enchanting beauty which we sometimes recognise in descriptions of very ordinary phenomena, will be found to arise from the force of imagination, by which the poet has connected with human emotions, a variety of objects, to which common minds could not discover their relation. What the poet does for his readers, however, by his original similes and metaphors in these higher cases, even the dullest of these readers do, in some degree, every day, for themselves, and the Beauty which is perceived, when natural objects are unexpectedly vivified by the glowing fancy of the former, is precisely of the same kind that is felt when the closeness of the analogy enables them to force human feelings upon the recollection of all mankind. As the poet sees more of Beauty in nature than ordinary mortals, just because he perceives more of these analogies and relations to social emotion, in which all Beauty consists; so, other men see more or less of this Beauty, exactly as they happen to possess that fancy, or those habits, which enable them readily to trace out these relations.

From all these sources of evidence, then, we think it is pretty well made out, that the Beauty or Sublimity of external objects is nothing but the reflection of emotions excited by the feelings or condition of sentient beings; and is produced altogether by certain little portions, as it were, of love, joy, pity, veneration, or terror, that adhere to those objects that are present on occasion of such emotions.—Nor, after what we have already said, does it seem to be necessary to reply to more than one of the objections to which we are aware that this theory is liable.—If Beauty be nothing more than a reflection of love, pity, or veneration, how comes it, it may be asked, to be distinguished from these sentiments? They are never confounded with each other, either in our feelings or our language:—Why, then, should they all be confounded under the common name of Beauty? and why should Beauty, in all cases, affect us in a way so different from the love or compassion of which it is said to be merely the reflection?

Now, to these questions, we are somewhat tempted to answer, after the manner of our country, by asking, in our turn, whether it be really true, that Beauty always affects us in one and the same manner, and always in a different manner from the simple and elementary affections which it is its office to recal to us? In very many cases, it appears to us, that the sensations which we receive from objects that are felt to be Beautiful, and that in the highest degree, do not differ at all from the direct movements of tenderness or pity towards sentient beings. If the epithet of Beauty be correctly (as it is universally) applied to many of the most admired and en-

Beauty.

Objectives—that the sense of Beauty is different from the emotions into which it is here resolved.

Answered, that it is not always.

Beauty. chasting passages in poetry, which consist entirely in the expression of affecting sentiments, the question would be speedily decided; and it is a fact, at all events, too remarkable to be omitted, that some of the most powerful and delightful emotions that are uniformly classed under this name, arise altogether from the direct influence of these pathetic emotions, without the intervention of any material imagery. We do not wish, however, to dwell upon an argument, which certainly is not applicable to all parts of the question; and, admitting that, on many occasions, the feelings which we experience from *Beauty*, are sensibly different from the primary emotions in which we think they originate, we shall endeavour, in a very few words, to give an explanation of this difference, which seems to be perfectly consistent with the theory we have undertaken to illustrate.

And explained, where it is.

In the first place, it should make some difference on the primary affections to which we have alluded, that, in the cases alluded to, they are *reflected* from material objects, and not directly excited by their natural causes. The light of the moon has a very different complexion from that of the sun;—though it is in substance the sun's light; and glimpses of interesting, or even of familiar objects, caught unexpectedly from a mirror placed at a distance from these objects, will affect us, like sudden allusions in poetry, very differently from the natural perception of those objects in their ordinary relations. In the next place, the emotion, when suggested in the shape of *Beauty*, comes upon us, for the most part, disencumbered of all those accompaniments which frequently give it a peculiar and less satisfactory character, when it arises from direct intercourse with its living objects. The compassion, for example, that is suggested by *Beauty* of a gentle and winning description, is not attended with any of that disgust and uneasiness which frequently accompany the spectacle of real distress; nor with that importunate suggestion of the duty of relieving it, from which it is almost inseparable. Nor does the temporary delight which we receive from *Beauty* of a gay and animating character, call upon us for any such expenditure of spirits, or active demonstrations of sympathy, as are sometimes demanded by the turbulence of real joy. In the third place, the emotion of *Beauty*, being partly founded upon illusion, is far more transitory in its own nature, and is both more apt to fluctuate and vary in its character, and more capable of being dismissed at pleasure, than any of the primary affections, whose shadow and representative it is. In the fourth place, the perception of *Beauty* implies a certain exercise of the imagination that is not required in the case of direct emotion, and is sufficient, of itself, both to give a new character to every emotion that is suggested by the intervention of such an exercise, and to account for our classing all the various emotions that are so suggested under the same denomination of *Beauty*. When we are injured, we feel indignation,—when we are wounded, we feel pain,—when we see suffering, we feel compassion,—and when we witness any splendid act of heroism or generosity, we feel admiration—without any effort of the imagination; or the intervention of any

Beauty. picture or vision in the mind. But when we feel indignation, or pity, or admiration, in consequence of seeing some piece of inanimate matter that merely suggests or recalls to us the ordinary causes or proper objects of these emotions, it is evident that our fancy is kindled by a sudden flash of recollection; and that the effect is produced by means of a certain poetical creation that is instantly conjured up in the mind. It is this active and heated state of the imagination, and this divided and busy occupation of the mind, that constitute the great peculiarity of the emotions we experience from the perception of *Beauty*.

Finally, and this is perhaps the most important consideration of the whole, it should be recollected, that, along with the shadow or suggestion of associated emotions, there is always present a real and direct perception, which not only gives a force and liveliness to all the images which it suggests, but seems to impart to them some share of its own reality. That there is an illusion of this kind in the case, is sufficiently demonstrated by the fact, that we invariably ascribe the interest, which we think has been proved to arise wholly from these associations, to the object itself, as one of its actual and inherent qualities, and consider *its* beauty as no less a property belonging to it, than any of its physical attributes. The associated interest, therefore, is beyond all doubt confounded with the present perception of the object itself; and a livelier and more instant impression is accordingly made upon the mind, than if the interesting conceptions had been merely excited in the memory by the usual operation of reflection or voluntary meditation. Something analogous to this is familiarly known to occur in other cases. When we merely think of an absent friend, our emotions are incomparably less lively than when the recollection of him is suddenly suggested by the unexpected sight of his picture, of the house where he dwelt, or the spot on which we last parted from him,—and all these objects seem for the moment to wear the colours of our own associated affections. When Captain Cook's companions found, in the remotest corner of the habitable globe, a broken spoon with the word *London* stamped upon it, and burst into tears at the sight,—they proved how differently we are moved by emotions thus connected with the real presence of an actual perception, than by the mere recollection of the objects on which those emotions depend. Every one of them had probably thought of *London* every day since he left it, and many of them might have been talking of it with tranquillity but a little before this more effectual appeal was made to their sensibility.

If we add to all this, that there is necessarily something of vagueness and variableness in the emotions most generally excited by the perception of *Beauty*, and that the mind wanders with the eye, over the different objects which may supply these emotions, with a degree of unsteadiness, and half voluntary half involuntary fluctuation, we may come to understand how the effect not only should be essentially different from that of the simple presentment of any one interesting conception, but should acquire a peculiarity which entitles it to a dif-

ferent denomination. Most of the associations of which we have been last speaking, as being founded on the analogies or fanciful resemblances that are felt to exist between physical objects and qualities, and the interesting affections of mind, are intrinsically of this vague and wavering description,—and when we look at a fine landscape, or any other scene of complicated Beauty, a great variety of such images are suddenly presented to the fancy, and as suddenly succeeded by others, as the eye ranges over the different features of which it is composed, and feeds upon the charms which it discloses. Now, the direct perception, in all such cases, not only perpetually accompanies the associated emotions, but is inextricably confounded with them in our feelings, and is even recognised upon reflection as the cause, not merely of their unusual strength, but of the several peculiarities by which we have shown that they are distinguished. It is not wonderful, therefore, either that emotions so circumstanced should not be classed along with similar affections, under circumstances extremely different, or that the perception of present existence, thus mixed up, and indissolubly confounded with interesting conceptions, should between them produce a sensation of so distinct a nature as naturally to be distinguished by a peculiar name,—or that the *Beauty* which results from this combination should, in ordinary language, be ascribed to the objects themselves,—the presence and perception of which is a necessary condition of its existence.

What we have now said is enough, we believe, to give an attentive reader that general conception of the theory before us, which is all that we can hope to give in the narrow limits to which we are confined. It may be observed, however, that we have spoken only of those sorts of Beauty which we think capable of being resolved into some passion, or emotion, or pretty lively sentiment of our nature; and though these are undoubtedly the highest and most decided kinds of Beauty, it is certain that there are many things called beautiful which cannot claim so lofty a connexion. It is necessary, therefore, to observe, that, though every thing that excites any feeling worthy to be called an *emotion* by its beauty or sublimity, will be found to be related to the natural objects of human passions or affections, there are many things which are pleasing or agreeable enough to be called beautiful, in consequence of their relation merely to human Convenience and Comfort;—many others that please by suggesting ideas of human skill and ingenuity;—and many that obtain the name of Beautiful, by being associated with human fortune, vanity, or splendour. After what has been already said, it will not be necessary either to exemplify or explain these subordinate phenomena. It is enough merely to suggest, that they all please upon the same great principle of sympathy with human feelings; and are explained by the simple and indisputable fact, that we are pleased with the direct contemplation of human comfort, ingenuity, and fortune. All these, indeed, obviously resolve themselves into the great object of sympathy—human enjoyment. Convenience and comfort is but another name for a lower, but very indispensable ingredient of that emotion. Skill and ingenuity rea-

dily present themselves as means by which enjoyment may be promoted; and high fortune, and opulence, and splendour, pass, at least at a distance, for its certain causes and attendants. The beauty of Fitness and adaptation of parts, even in the works of nature, is derived from the same fountain,—partly by means of its obvious analogy to works of human skill, and partly by suggestions of that creative Power and Wisdom, to which human destiny is subjected. The feelings, therefore, associated with all those qualities, though scarcely rising to the height of emotion, are obviously in a certain degree pleasing or interesting; and when several of them happen to be united in one object, may accumulate to a very great degree of Beauty. It is needless, we think, to pursue these general propositions through all the details to which they so obviously lead. We shall confine ourselves, therefore, to a very few remarks upon the Beauty of Architecture,—and chiefly as an illustration of our general position.

There are few things, about which men of *virtu* are more apt to rave, than the merits of the Grecian architecture; and most of those who affect an uncommon purity and delicacy of taste, talk of the intrinsic Beauty of its Proportions as a thing not to be disputed, except by barbarian ignorance and stupidity. Mr Alison, we think, was the first who gave a full and convincing refutation of this mysterious dogma; and, while he admits, in the most ample terms, the beauty of the objects in question, has shown, we think, in the clearest manner, that it arises entirely from the combination of the following associations:—1st, The association of utility, convenience, or fitness for the purposes of the building; 2d, Of security and stability, with a view to the nature of the materials; 3d, Of the skill and power requisite to mould such materials into forms so commodious; 4th, Of magnificence, and splendour, and expence; 5th, Of antiquity; and, 6thly, Of Roman and Grecian greatness. His observations are summed up in the following short sentence.

“The proportions,” he observes, “of these orders, it is to be remembered, are distinct subjects of Beauty, from the ornaments with which they are embellished, from the magnificence with which they are executed, from the purposes of elegance they are intended to serve, or the scenes of grandeur they are destined to adorn. It is in such scenes, however, and with such additions, that we are accustomed to observe them; and, while we feel the effect of all these accidental associations, we are seldom willing to examine what are the causes of the complex emotion we feel, and readily attribute to the nature of the architecture itself, the whole pleasure which we enjoy. But, besides these, there are other associations we have with these forms, that still more powerfully serve to command our admiration; for they are the *GRECIAN* orders; they derive their origin from those times, and were the ornament of those countries which are most hallowed in our imaginations; and it is difficult for us to see them, even in their modern copies, without feeling them operate upon our minds as relics of those polished nations where they first arose, and of that greater people by whom they were afterwards borrowed.”

Associations with ideas of comfort, genius, power, or splendour: also the sources of Beauty.

Beauty.

This analysis is to us perfectly satisfactory. But, indeed, we cannot conceive any more complete refutation of the notion of an intrinsic and inherent Beauty in the proportions of the Grecian architecture, than the fact of the admitted Beauty of such very opposite proportions in the Gothic. Opposite as they are, however, the great elements of Beauty are the same in this style as in the other,—the impressions of religious awe and of chivalrous recollections, coming here in place of the classical associations which constitute so great a share of the interest of the former. It is well observed by Mr Alison, that the great Durability and Costliness of the productions of this art, have had the effect, in almost all regions of the world, of rendering their fashion permanent, after it had once attained such a degree of perfection as to fulfil its substantial purposes.

“Buildings,” he observes, “may last, and are intended to last for centuries. The life of man is very inadequate to the duration of such productions; and the present period of the world, though old with respect to those arts which are employed upon perishable subjects, is yet young in relation to an art, which is employed upon so durable materials as those of architecture. Instead of a few years, therefore, centuries must probably pass before such productions demand to be renewed; and, long before that period is elapsed, the sacredness of antiquity is acquired by the subject itself, and a new motive given for the preservation of similar forms. In every country, accordingly, the same effect has taken place: and the same causes which have thus served to produce among us, for so many years, an uniformity of taste with regard to the style of Grecian architecture, have produced also among the nations of the East, for a much longer course of time, a similar uniformity of taste with regard to their ornamental style of architecture; and have perpetuated among them the same forms which were in use among their forefathers, before the Grecian orders were invented.”

It is not necessary, we think, to carry these illustrations any farther: as the theory they are intended to explain, is now, we believe, universally adopted, though with some limitations, which we see no reason to retain. Those suggested by Mr Alison, we have already endeavoured to dispose of in the few remarks we have made upon his publication; and it only remains to say a word or two more upon Mr Knight's doctrine as to the primitive and independent Beauty of Colours, upon which we have already hazarded some remarks.

Agreeing as he does with Mr Alison, and all modern inquirers, that the whole Beauty of objects consists, in the far greater number of instances, in the associations to which we have alluded, he still maintains, that some few visible objects affect us with a sense of Beauty in consequence of the pleasurable impression they make upon the sense—and that our perception of Beauty is, in these instances, a mere organic sensation. Now, we have already stated, that it would be something quite unexampled in the history either of mind or of language, if certain physical and bodily sensations should thus be confounded with moral and social feelings with which they

had no connection, and pass familiarly under one and the same name. Beauty consists confessedly, in almost all cases, in *the suggestion* of moral or social emotions, mixed up and modified by a present sensation or perception; and it is this suggestion, and this identification with a present object, that constitutes its essence, and gives a common character to the whole class of feelings it produces, sufficient to justify their being designated by a common appellation. If the word Beauty, in short, must mean something, and if *this* be very clearly what it means in all remarkable instances, it is difficult to conceive, that it should occasionally mean something quite different, and denote a mere sensual or physical gratification, unaccompanied by the suggestion of any moral emotion whatever. According to Mr Knight, however, and, indeed, to most other writers, this is the case with regard to the Beauty of Colours, which depends altogether, they say, upon the delight which the eye naturally takes in their contemplation—this delight being just as primitive and sensual as that which the palate receives from the contact of agreeable flavours.

It must be admitted, we think, in the first place, that such an allegation is in itself extremely improbable, and contrary to all analogy, and all experience of the structure of language, or of the laws of thought. It is farther to be considered, too, that if the pleasures of the senses are ever to be considered as Beautiful, those pleasures which are the most lively and important would be the most likely to usurp this denomination, and to take rank with the higher gratifications that result from the perception of Beauty. Now, it admits of no dispute, that the mere organic pleasures of the eye are far inferior to those of the palate, the touch, and indeed almost all the other senses,—none of which, however, are in any case confounded with the sense of Beauty. In the next place, it should follow, that if what affords organic pleasure to the eye be properly called Beautiful, what offends, or gives pain to it, should be called ugly. Now, excessive or dazzling light is offensive to the eye—but, considered by itself, it is never called ugly, but only painful or disagreeable. The moderate excitement of light, on the other hand, or the soothing of certain bright but temperate colours, when considered in this primary aspect, are scarcely called Beautiful, but only agreeable or refreshing. So far as the direct injury or comfort of the organ, in short, is concerned, the language which we use refers merely to physical or bodily sensation, and is not confounded with that which relates to mental emotion; and we really see no ground for supposing that there is any exception to this rule.

It is very remarkable, indeed, that the sense whose organic gratification is here supposed to constitute the feeling of Beauty, should be one, in the first place, whose direct organic gratifications are of very little force or intensity;—and, in the next place, one whose office it is, almost exclusively, to make us acquainted with the existence and properties of those external objects which are naturally interesting to our inward feelings and affections. This peculiarity makes it extremely probable, that ideas of emotion should be associated with the perceptions of

Beauty.

Reasons for disputing this Doctrine.

Examination of Mr Knight's Doctrine as to the original and independent Beauty of Colours.

Beauty. this sense, but extremely improbable, that its naked and unassociated sensations should in any case be classed with such emotions. If the name of Beauty were given to what directly gratifies any sense, such as that of tasting or smelling, which does not make us acquainted with the nature or relations of outward objects, there could be less room for such an explanation. But when it is the business of a particular sense or organ to introduce to our knowledge those objects which are naturally connected with ideas of emotion, it is easy to understand how its perceptions should be associated with these emotions, and an interest and importance thus extended to them, that belong to the intimations of no other bodily organ. But, on those very accounts, we should be prepared to suspect, that all the interest they possess is derived from this association; and to distrust the accuracy of any observations that may lead us to conclude that its mere organic impulses ever produced any thing akin to these associated emotions, or entitled to pass under their name. This caution will appear still more reasonable, when it is considered, that all the other qualities of visible objects, except only their colours, are now admitted to be perfectly indifferent in themselves, and to possess no other Beauty than they may derive from their associations with our ordinary affections. There are no forms, for example, even in Mr Knight's opinion, that have any intrinsic Beauty, or any power of pleasing or affecting us, except through their associations, or affinities to mental affections, either as expressive of Fitness and Utility, or as types and symbols of certain moral or intellectual qualities, in which the sources of our interest are obvious. Yet the Form of an object is as conspicuous an ingredient of its Beauty as its Colour, and a property, too, which seems at first view to be as intrinsically and independently pleasing. Why, then, should we persist in holding that colours, or combinations of colours, please from being naturally agreeable to the organ of sight, when it is admitted that other visible qualities, which seem to possess the same power of pleasing, are found, upon examination, to owe it entirely to the principle of association?

The only reason that can be assigned, or that actually exists for this distinction, is, that it has been supposed more difficult to account for the Beauty of Colours, upon the principles which have accounted for other Beauties, or to specify the particular associations by virtue of which they could acquire this quality. Now, it appears to us that there is no such difficulty; and that there is no reason whatever for holding that one colour, or combination of colours, is more pleasing than another, except upon the same grounds of association which recommend particular forms, motions, or proportions. It appears to us, that the organic pleasures of the eye are extremely few and insignificant. It is hurt, no doubt, by an excessive glare of light; and it is in some degree gratified, perhaps, by a moderate degree of it. But it is only by the quantity or intensity of the light we think that it is so affected. The colour of it, we take it, is, in all cases, absolutely indifferent. But it is the colour only that is called Beautiful or otherwise; and these qualities we think it very plainly derives from the common fountain of association.

Beauty. In the first place, we would ask, whether there is any colour that is beautiful in all situations? and, in the next place, whether there is any colour that is not beautiful in some situation? With regard to the first, take the colours that are most commonly referred to as being intrinsically beautiful—bright and soft green—clear blue—bright pink, or vermilion. The first is unquestionably beautiful in vernal woods and summer meadows;—and, we humbly conceive, is Beautiful, because it is the Natural sign and concomitant of those scenes and seasons of enjoyment. Blue, again, is beautiful in the vernal sky;—and, as we believe, for the sake of the pleasures of which such skies are prolific; and pink is beautiful on the cheeks of a young woman or the leaves of a rose, for reasons too obvious to be stated. We have associations enough, therefore, to recommend all these colours, in the situations in which they are beautiful; but, strong as these associations are, they are unable to make them universally beautiful,—or beautiful, indeed, in any other situations. Green would not be beautiful in the sky—nor blue on the cheek—nor vermilion on the grass. It may be said, indeed, that, though they are always recognised as beautiful in themselves, their obvious unfitness in such situations counteracts the effect of their Beauty, and make an opposite impression, as of something monstrous and unnatural; and that, accordingly, they are all beautiful in indifferent situations, where there is no such antagonist principle—in furniture, dress, and ornaments. Now the fact, in the first place, is not so;—these bright colours being but seldom and sparingly admitted in ornaments or works of art; and no man, for example, choosing to have a blue house, or a green ceiling, or a pink coat. But, in the second place, if the facts were admitted, we think it obvious, that the general Beauty of these colours would be sufficiently accounted for by the very interesting and powerful associations under which all of them are so frequently presented by the hand of Nature. The interest we take in female beauty,—in vernal delights,—in unclouded skies,—is far too lively and too constantly recurring, not to stamp a kindred interest upon the colours that are Naturally associated with such objects, and to make us regard with some affection and delight those hues that remind us of them, although we should only meet them upon a fan, or a dressing-box, the lining of a curtain, or the back of a screen. Finally, we beg leave to observe, that all bright and clear colours are naturally typical of cheerfulness and purity of mind, and are hailed as emblems of moral qualities, to which no one can be indifferent.

Beauty. With regard to ugly colours again, we really are not aware of any to which that epithet can be safely applied. Dull and dingy hues are usually mentioned as in themselves the least pleasing. Yet these are the prevailing tints in many beautiful landscapes, and many admired pictures. They are also the most common colours that are chosen for dress,—for building,—for furniture,—where the consideration of Beauty is the only motive for the choice. In fact, the shaded parts of all coloured objects pass into tints of this description:—nor can we at present recollect any one colour, which we could specify as in itself disagreeable, without running counter to the

Beauty of Colours derived from Association alone.

Beauty. feelings and the practice of the great mass of mankind. If the fact, however, were otherwise, and if certain muddy and dull colours were universally allowed to be disagreeable, we should think there could be no difficulty in referring these, too, to natural associations. Darkness, and all that approaches it, is naturally associated with ideas of melancholy,—of helplessness, and danger;—and the gloomy hues that remind us of it, or seem to draw upon it, must share in the same associations. Lurid skies, too, it should be observed, and turbid waters, and unfruitful swamps, and dreary morasses, are the Natural and most common wearers of these dismal liveries. It is from these that we first become acquainted with them; and it is needless, therefore, to say, that such objects are necessarily associated with ideas of discomfort, and sadness, and danger; and that the colours that remind us of them, can scarcely fail to recal some of the same disagreeable sensations.

Beauty of Mixed or Combined Colours.

Enough, however, and more than enough, has been said about the supposed primitive and independent Beauty of separate colours. It is chiefly upon the intrinsic Beauty of their mixture or combinations that Mr Knight and his adherents have insisted;—and it is no doubt quite true, that, among painters and connoisseurs, we hear a great deal about the harmony and composition of tints, and the charms and difficulties of a judicious colouring. In all this, however, we cannot help suspecting that there is no little pedantry, and no little jargon; and that these phrases, when used without reference to the practical difficulties of the art, which must go for nothing in the present question, really mean little more than the true and natural appearance of coloured objects, seen through the same tinted or partially obscure medium that commonly constitutes the atmosphere. In nature, we know of no discordant or offensive colouring, except what may be referred to some accident or disaster that spoils the moral or sentimental expression of the scene, and disturbs the associations upon which all its Beauty, whether of forms or of hues, seems to us very plainly dependent. We are perfectly aware, that ingenious persons have been disposed to dogmatize and to speculate very confidently upon these subjects; and have had the benefit of seeing various learned treatises upon the natural *gamut* of colours, and the inherent congruity of those that are called complementary, with reference to the prismatic *spectrum*. But we confess we have no faith in any of those fancies; and believe, that, if all these colours were fairly arranged on a plain board, according to the most rigid rules of this supposed harmony, nobody, but the author of the theory, would perceive the smallest Beauty in the exhibition, or be the least offended by reversing their collocation.

We do not mean, however, to dispute, that the laws of colouring, insisted on by learned artists, will produce a more pleasing effect upon *trained judges of the art*, than a neglect of these laws; because we have little doubt that these combinations of colour are recommended by certain associations, which render them generally pleasing to persons so trained and educated;—all that we maintain is, that there are no combinations that are originally and Universally pleasing or displeasing to the eye, independent of

Beauty. such associations; and it seems to us an irresistible proof of this, that these laws of harmonious colouring are perpetually and deliberately violated by great multitudes of persons, who not only have the perfect use of their sight, but are actually bestowing great pains and expence in providing for its gratification, in the very act of this violation. The Dutch trader, who paints over the outside of his country-house with as many bright colours as are to be found in his tulip-bed, and garnishes his green shutters with blue facings, and his purple roof with lilac ridges,—not only sees as well as the studied colourist, who shudders at the exhibition, but actually receives as much pleasure, and as strong an impression of Beauty, from the finished *lusthaus*, as the artist does from one of his best pictures. It is impossible, then, that these combinations of colours can be *naturally* or *intrinsically* offensive to the organ of sight; and their Beauty or ugliness *must* depend upon the associations which different individuals may have happened to form with regard to them. We contend, however, for nothing more; and are quite willing to allow that the associations which recommend his staring tawdriness to the burgomaster, are such as could not easily have been formed in the mind of a diligent and extensive observer of nature, and that they would probably be reversed by habits of reflection and study. But the same thing, it is obvious, may be said of the notions of beauty of any other description that prevail among the rude, the inexperienced, and uninstructed;—though, in all other instances, we take it for granted, that the Beauty which is perceived depends altogether upon association, and in no degree on its power of giving a pleasurable impulse to the organ to which it addresses itself. If any considerable number of persons, with the perfect use of sight, actually take pleasure in certain combinations of colours,—that is complete proof that such combinations are not *Naturally* offensive to the organ of sight, and that the pleasure of such persons, exactly like that of those who disagree with them, is derived not from the sense, but from associations with its perceptions.

With regard, again, to the effect of broken masses of light and shadow, it is proper, in the first place, to remember, that by the eye we see *colour only*; and that lights and shadows, as far as the mere organ is concerned, mean nothing but variations of tint. It is very true, no doubt, that we soon learn to refer many of those variations to light and shade, and that they thus become *signs* to us of depth, and distance, and relief. But, is not this, of itself, sufficient to refute the idea of their affording any primitive or organic pleasure? In so far as they are mere variations of tints, they may be imitated by unmeaning daubs of paint on a pallet;—in so far as they are *signs*, it is to the mind that they address themselves, and not to the organ. They are signs, too, it should be recollected, and the only signs we have, by which we can receive any correct knowledge of the existence and condition of all external objects at a distance from us, whether interesting or not interesting. Without the assistance of variety of tint, and of lights and shadows, we could never distinguish one object from another, except by the

Effects of Light and Shadow.

Beauty.

touch. These appearances, therefore, are the perpetual vehicles of almost all our interesting perceptions; and are consequently associated with all the emotions we receive from visible objects. It is pleasant to see *many* things in one prospect, because some of them are probably agreeable; and it is pleasant to know the relations of those things, because the qualities or associations, by means of which they interest us, generally depend upon that knowledge. The mixture of colours and shades, however, is necessary to this enjoyment, and consequently is a sign of it, and a source of associated interest or beauty.

Opinion of Mr Knight, that the Beauty of many Pictures depends mainly on the intrinsic Beauty of their Colours.

Mr Knight, however, goes much farther than this; and maintains, that the Beauty which is so distinctly felt in many pictures of objects in themselves disagreeable, is to be ascribed entirely to the effect of the brilliant and harmonious tints, and the masses of light and shadow that may be employed in the representation. The filthy and tattered rags of a beggar, he observes, and the putrifying contents of a dunghill, may form beautiful objects in a picture; because, considered as mere objects of sight, they may often present beautiful effects of colouring and shadow; and these are preserved or heightened in the imitation, disjoined from all their offensive accompaniments. Now, if the tints and shades were the exclusive sources of our gratification, and if this gratification was diminished, instead of being heightened, by the suggestion which, however transiently, *must* still intrude itself, that they appeared in an imitation of disgusting objects, it must certainly follow, that the pleasure and the beauty would be much enhanced if there was *no imitation of any thing whatever*, and if the canvas merely presented the tints and shades, unaccompanied with the representation of any particular object. It is perfectly obvious, however, that it would be absurd to call such a collection of coloured spots a beautiful picture; and that a man would be laughed at who should hang up such a piece of stained canvas among the works of the great artists. Again, if it were really possible for any one, but a student of art, to confine the attention to the mere colouring and shadowing of any picture, there is nothing so disgusting but what might form the subject of a beautiful imitation. A piece of putrid veal, or a cancerous ulcer, or the rags that are taken from it, may display the most brilliant tints, and the finest distribution of light and shadow. Does Mr Knight, however, seriously think, that either of these experiments would succeed? Or, are there, in reality, no other qualities in the pictures in question, to which their beauty can be ascribed, but the organic effect of their colours? We humbly conceive that there are; and that far less ingenuity than his might have been able to detect them.

Refuted, 1st, By Facts inconsistent with it;—and,

2dly, By a better and more natural Explanation of the instances on which he relies.

There is, in the first place, the pleasing association of the Skill and Power of the artist,—a skill and power which we know *may* be employed to produce unmingled delight; whatever may be the character of the particular effort before us. But, in the second place, we do humbly conceive that there are many interesting associations connected with the subjects which have been represented as purely disgusting. The aspect of human wretchedness and decay is not,

Beauty.

at all events, an *indifferent* spectacle; and, if presented to us without actual offence to our senses, or any call on our active beneficence, may excite a sympathetic emotion, which is known to be far from undelightful. Many an attractive poem has been written on the miseries of beggars; and why should painting be supposed more fastidious? Besides, it will be observed, that the beggars of the painter are generally among the most interesting of that interesting order;—either young and lovely children, whose health and gaiety, and sweet expression, form an affecting contrast with their squalid garments, and the neglect and misery to which they seem to be destined,—or old and venerable persons, mingling something of the dignity and reverence of age with the broken spirit of their condition, and seeming to reproach mankind for exposing heads so old and white to the pelting of the pitiless storm. While such pictures suggest images so pathetic, it looks almost like a wilful perversity, to ascribe their Beauty entirely to the mixture of colours which they display, and to the forgetfulness of these images. Even for the dunghill, we think it is possible to say something,—though, we confess, we have never happened to see any picture, of which that useful compound formed the peculiar subject. There is the display of the painter's art and power here also; and the dunghill is not only Useful, but is associated with many pleasing images of rustic toil and occupation; and of the simplicity, and comfort, and innocence of agricultural life. We do not know that a dunghill is at all a disagreeable object to look at, even in plain reality—provided it be so far off as not to annoy us with its odour, or to soil us with its effusions. In a picture, however, we are safe from any of these disasters; and, considering that it is usually combined, in such delineations, with other more pleasing and touching remembrancers of humble happiness and contentment, we really do not see that it was at all necessary to impute any mysterious or intrinsic Beauty to its complexion, in order to account for the satisfaction with which we can then bear to behold it.

Having said so much with a view to reduce to its just value, as an ingredient of Beauty, the mere organic delight which the eye is supposed to derive from colours, we really have not patience to apply the same considerations to the alleged Beauty of Sounds that are supposed to be insignificant. Beautiful Sounds, in general, we think, are Beautiful from association only,—from their resembling the natural tones of various passions and affections,—or from their being originally and most frequently presented to us in scenes or on occasions of natural interest or emotion. With regard, again, to successive or coexistent sounds, we do not, of course, mean to dispute, that there are such things as Melody and Harmony, and that most men are offended or gratified by the violation or observance of those laws upon which they depend. This, however, it should be observed, is a faculty quite *unique*, and unlike anything else in our constitution; by no means universal, as the sense of Beauty is, even in cultivated societies, and apparently withheld from whole communities of quick-eared savages and barbarians. Whether the kind of gratification, which results from the mere musical arrange-

The Beauty of Sounds all derived from Association.

Beauty. ment of sounds, would be referred to a sense of Beauty, or would pass under that name, if it could be presented entirely detached from any associated emotions, appears to us to be exceedingly doubtful. Even with the benefit of these combinations, we do not find, that every arrangement which merely preserves inviolate the rules of composition, is considered as Beautiful; and we do not think that it would be consonant, either to the common feeling or common language of mankind, to bestow this epithet upon pieces that had no other merit. At all events, and whatever may be thought of the proper name of this singular gratification of a musical ear, it seems to be quite certain, that all that rises to the dignity of an *emotion* in the pleasure we receive from sounds, is as clearly the gift of association, as in the case of visible beauty,—of association with the passionate tones and modulations of the human voice,—with the scenes to which the interesting sounds are native,—with the poetry to which they have been married,—or even with the skill and Genius of the artist by whom they have been arranged.

tural object of love, pity, admiration, or awe. The interest of material objects, therefore, is always *the same*; and arises, in every case, not from any physical qualities they may possess, but from their association with some idea of emotion. But, though material objects have but one means of exciting emotion, the emotions they do excite are infinite. They are mirrors that may reflect all shades and all colours; and, in point of fact, do seldom reflect the same hues twice. No two interesting objects, perhaps, whether known by the name of Beautiful, Sublime, or Picturesque, ever produced exactly the same emotion in the beholder; and no one object, it is most probable, ever moved any two persons to the very same conceptions. As they may be associated with all the feelings and affections of which the human mind is susceptible, so they may suggest those feelings in all their variety, and, in fact, do daily excite all sorts of emotions—running through every gradation, from extreme gaiety and elevation, to the borders of horror and disgust.

Beauty.

Beauty of Immaterial Objects referable to the same sources.

Hitherto we have spoken of the Beauty of external objects only. But the whole difficulty of the theory consists in its application to them. If that be once adjusted, the Beauty of immaterial objects can occasion no perplexity. Poems, and other compositions in words, are Beautiful in proportion as they are conversant with Beautiful objects—or as they suggest to us, in a more direct way, the Moral and social emotions on which the Beauty of all objects depends. Theorems and demonstrations are Beautiful, according as they excite in us emotions of admiration for the Genius and intellectual Power of their inventors, and images of the magnificent and beneficial ends to which such discoveries may be applied;—and mechanical contrivances are Beautiful when they remind us of similar Talents and ingenuity, and at the same time impress us with a more direct sense of their vast Utility to mankind, and of the great additional conveniences with which life is consequently adorned. In all cases, therefore, there is the suggestion of some interesting conception or emotion associated with a present perception, in which it is apparently confounded and embodied—and this, according to the whole of the preceding deduction, is the distinguishing characteristic of Beauty.

Now, it is certainly true, that all the variety of emotions raised in this way, on the single basis of association, may be classed, in a rude way, under the denominations of Sublime, Beautiful, and Picturesque, according as they partake of awe, tenderness, or admiration; and we have no other objection to this nomenclature, except its extreme imperfection, and the delusions to which we know that it has given occasion. If objects that interest by their association with ideas of Power, and Danger, and Terror, are to be distinguished by the peculiar name of Sublime, why should there not be a separate name also for objects that interest by associations of Mirth and Gaiety,—another for those that please by suggestions of Softness and Melancholy,—another for such as are connected with impressions of Comfort and Tranquillity,—and another and another for those that are related to Pity, and admiration, and love, and regret, and all the other distinct emotions and affections of our nature? These are not in reality less distinguishable from each other, than from the emotions of awe and veneration that confer the title of Sublime on their representatives; and while all the former are confounded under the comprehensive appellation of Beauty, this partial attempt at distinction is only apt to mislead us into an erroneous opinion of our accuracy, and to make us believe, both that there is a greater conformity among the things that pass under the same name, and a greater difference between those that pass under different names, than is really the case. We have seen already, that the radical error of almost all preceding inquirers, has lain in supposing that every thing that passed under the name of Beautiful, must have some real and inherent quality in common with every thing else that obtained that name: And it is scarcely necessary for us to observe, that it has been almost as general an opinion, that Sublimity was not only something radically different from Beauty, but actually opposite to it; whereas the fact is, that it is far more nearly related to some sorts of Beauty, than many sorts of Beauty are to each other; and that both are founded exactly upon the same principle of suggesting some past or possible emotion of some sentient being.

Consequences of this Theory, —First, to establish the identity of the Beautiful, the Sublime, and the Picturesque.

Having now explained, as fully as we think necessary, the grounds of that opinion as to the nature of Beauty which appears to be most conformable to the truth—we have only to add a word or two as to the necessary consequences of its adoption upon several other controversies of a kindred description.

In the first place, then, we conceive that it establishes the substantial identity of the Sublime, the Beautiful, and the Picturesque; and, consequently, puts an end to all controversy that is not purely verbal, as to the difference of those several qualities. Every material object that interests, without actually hurting or gratifying our bodily feelings, must do so, according to this theory, in one and the same manner,—that is, by suggesting or recalling some emotion or affection of ourselves, or some other sentient being, and presenting, to our imagination at least, some na-

Beauty:

Upon this important point, we are happy to find our opinions confirmed by the authority of Mr Stewart, who, in his Essay on the Beautiful, already referred to, has observed, not only that there appears to him to be no inconsistency or impropriety in such expressions as the *Sublime Beauties* of nature, or of the sacred Scriptures;—but has added, in express terms, that, “to oppose the Beautiful to the Sublime, or to the picturesque, strikes him as something analogous to a contrast between the Beautiful and the Comic—the Beautiful and the Tragic—the Beautiful and the Pathetic—or the Beautiful and the Romantic.”

Secondly,
To put an
end to Dis-
putes about
the Stand-
ard of Taste.

The only other advantage which we shall specify as likely to result from the general adoption of the theory we have been endeavouring to illustrate, is, that it seems calculated to put an end to all these perplexing and vexatious questions about the Standard of Taste, which have given occasion to so much impertinent and so much elaborate discussion. If things are not Beautiful in themselves, but only as they serve to suggest interesting conceptions to the mind, then every thing which does in point of fact suggest such a conception to any individual, *is Beautiful* to that individual; and it is not only quite true that there is no room for disputing about tastes, but that all tastes are equally just and correct, in so far as each individual speaks only of his own emotions. When a man calls a thing Beautiful, however, he may indeed mean to make two very different assertions;—he may mean that it gives *him* pleasure, by suggesting to him some interesting emotion; and, in this sense, there can be no doubt that, if he merely speak truth, the thing is beautiful; and that it pleases him precisely in the same way that all other things please those to whom they appear beautiful. But if he mean farther to say that the thing possesses some quality which should make it appear Beautiful to every other person, and that it is owing to some prejudice or defect in them if it appear otherwise, then he is as unreasonable and absurd as he would think those who should attempt to convince him that he felt no emotion of Beauty.

All tastes, then, are equally just and true, in so far as concerns the individual whose taste is in question; and what a man feels distinctly to be beautiful, *is Beautiful* to him, whatever other people may think of it. All this follows clearly from the theory now in question: But it does not follow, from it, that all tastes are equally good or desirable, or that there is any difficulty in describing that which is really the best, and the most to be envied. The only use of the faculty of Taste, is to afford an innocent delight, and to aid the cultivation of a finer morality; and that man certainly will have the most delight from this faculty, who has the most numerous and the most powerful perceptions of Beauty. But, if Beauty consist in the reflection of our affections and sympathies, it is plain that *he* will always see the most Beauty whose affections are warmest and most exercised,—whose imagination is the most powerful, and who has most accustomed himself to attend to the objects by which he is surrounded. In so far as mere feeling and enjoyment are concerned, therefore, it seems evident, that the best taste must be that which belongs to the best Affections, the most

Beauty.

active Fancy, and the most attentive habits of Observation. It will follow pretty exactly too, that all men's perceptions of Beauty will be nearly in proportion to the degree of their sensibility and social sympathies; and that those who have no affections towards sentient beings, will be just as insensible to Beauty in external objects, as he, who cannot hear the sound of his friend's voice, must be deaf to its echo.

In so far as the sense of Beauty is regarded as a mere source of enjoyment, this seems to be the only distinction that deserves to be attended to; and the only cultivation that Taste should ever receive, with a view to the gratification of the individual, should be through the indirect channel of cultivating the affections and powers of observation. If we aspire, however, to be *creators*, as well as observers of Beauty, and place any part of our happiness in ministering to the gratification of others—as artists, or poets, or authors of any sort—then, indeed, a new distinction of Tastes, and a far more laborious system of cultivation, will be necessary. A man who pursues only his own delight, will be as much charmed with objects that suggest powerful emotions in consequence of personal and accidental associations, as with those that introduce similar emotions by means of associations that are universal and indestructible. To him, all objects of the former class are really as beautiful as those of the latter—and, for his own gratification, the creation of that sort of Beauty is just as important an occupation: But if he conceive the ambition of creating beauties for the admiration of others, he must be cautious to employ only such objects as are the *natural* signs, or the *inseparable* concomitants of emotions, of which the greater part of mankind are susceptible; and his taste will *then* deserve to be called bad and false, if he obtrude upon the public, as beautiful, objects that are not likely to be associated in common minds with any interesting impressions.

For a man himself, then, there is no taste that is either bad or false; and the only difference worthy of being attended to, is that between a great deal and a very little. Some who have cold affections, sluggish imaginations, and no habits of observation, can with difficulty discern Beauty in any thing; while others, who are full of kindness and sensibility, and who have been accustomed to attend to all the objects around them, feel it almost in everything. It is no matter what other people may think of the objects of their admiration; nor ought it to be any concern of theirs that the public would be astonished or offended, if they were called upon to join in that admiration. So long as no such call is made, this anticipated discrepancy of feeling need give *them* no uneasiness; and the suspicion of it should produce no contempt in any other persons. It is a strange aberration indeed of vanity that makes us despise persons for being happy—for having sources of enjoyment in which we cannot share:—And yet this is the true account of the ridicule, which is so generally poured upon individuals who seek only to enjoy their peculiar tastes unmolested:—For, if there be any truth in the theory we have been expounding, no taste is bad for any other reason than because it is peculiar—as the objects in which it de-

Beauty
||
Beccaria.

lights must actually serve to suggest to the individual those common emotions and universal affections upon which the sense of Beauty is everywhere founded. The misfortune is, however, that we are apt to consider all persons who make known their peculiar relishes, and especially all who create any objects for their gratification, as in some measure dictating to the public, and setting up an idol for general adoration; and hence this intolerant interference with almost all peculiar perceptions of beauty, and the unsparing derision that pursues all deviations from acknowledged standards. This intolerance, we admit, is often provoked by something of a spirit of *prosllytism* and arrogance, in those who mistake their own casual associations for natural or universal relations; and the consequence is, that mortified vanity dries up the fountain of their peculiar enjoyment, and disenchant, by a new association of general contempt

or ridicule, the scenes that had been consecrated by some innocent but accidental emotion.

As all men must have some peculiar associations, all men must have some peculiar notions of beauty, and, of course, to a certain extent, a taste that the public would be entitled to consider as false or vitiated. For those who make no demands on public admiration, however, it is hard to be obliged to sacrifice this source of enjoyment; and, even for those who labour for applause, the wisest course, perhaps, if it were only practicable, would be, to have two tastes,—one to enjoy, and one to work by,—one founded upon Universal associations, according to which they finished those performances for which they challenged universal praise,—and another guided by all casual and individual associations, through which they looked fondly upon nature, and upon the objects of their secret admiration. (GG.)

Beauty
||
Beccaria.

BECCARIA (CESAR BONESANA, MARQUIS OF), author of the well known treatise on *Crimes and Punishments*, was born at Milan in the year 1735. His early studies were carried on in the College of the Jesuits at Parma. He possessed a quick apprehension; but, being naturally taciturn, and inclined to reflection, he seldom communicated the progress of his ideas, and was with difficulty prevailed upon to complete his exercises. It is related, as another peculiarity of his disposition, that he never received praise from his teachers without betraying evident marks of pain and humiliation. These unusual indications of a susceptible mind, which, outstripping the course of his instructors, delighted in its own pursuits, and derived little complacency from a sense of its actual attainments, gave him, to common observers, a certain air of slowness, and even of stupidity; and characterized his features and deportment during the whole of his life. Having left the college at the age of seventeen, he applied himself, with unremitting diligence, to the study of Mathematics, and the Philosophy of Man.

His understanding appears to have been very early capable of embracing the most general views, and his breast to have been warmed by those benevolent wishes for the enlargement of human happiness, the sincerity and the strength of which are often so severely tried by the events and passions of maturer life. His propensity to the study of Jurisprudence, and Political Philosophy, was first excited or confirmed by the *Lettres Persannes* of Montesquieu; a production capable, indeed, of alluring a less enthusiastic mind than that of Beccaria. But his industry, in the pursuit of knowledge, appears to have been chiefly stimulated by the patriotic and honourable desire of diffusing instruction among his countrymen, particularly the inhabitants of Milan, whom he represents, in one of his letters, as abandoned to a state of lamentable and universal ignorance. In

the prosecution of these laudable designs, he fortunately possessed the confidence, and was encouraged by the protection, of Count Firmiani, then governor of that part of the Austrian dominions; an accomplished nobleman, who, with comprehensive views of policy, concurred in every plan which was calculated for improving the state of the provinces, and the condition of their inhabitants.

Beccaria first appeared as an author in the year 1762, when he published some observations on the Derangement of the Currency in the Milanese States, and a plan for its amendment. Soon after this he established a small literary society at Milan, in concert with some associates of character and sentiments similar to his own; among others, *Alessandro* and *Pietro Verri*, who likewise contributed at that time, by their talents and public spirit, to distinguish the reign of Maria Teresa in Lombardy.* Assisted by these friends, and countenanced by Firmiani, he commenced a periodical publication under the name of the *Caffè*; a plan said to have been suggested to them by the celebrity of Addison's *Spectator*, and the general belief of its influence on the opinions and taste of the people of England. Various papers, contributed by the members of this society, on subjects of literature, ethics, and physical science, were published during the years 1764 and 1765.

But by far the most remarkable production to which this society gave rise, and that by which the reputation of Beccaria has been chiefly perpetuated among other nations, was the treatise on Crimes and Punishments (*Dei Delitti e Delle Pene*). This essay is said to have been undertaken at the earnest solicitation of Count Alexander Verri, who then discharged the functions of Protector of Prisoners (*Protettore de' Carcerati*) at the Court of Milan. It was written at the house of his brother, Peter Verri, where the meetings of the society were held; and in concert with him the author, every evening, revised

* A small publication which appeared about that time, under the title of *Thoughts on Happiness*, was written by the former. His literary pursuits were, soon after, suspended by his appointment to a public situation.

Beccaria.

and corrected what he had written during the day. In this manner the work was completed within two months, and was printed in the course of the year 1764, with the mark of the Lucca press.*

In this small but noted work, the author appears as the advocate of reason and sound policy, no less than of humanity. It was his purpose, by examining the foundation, the objects, and consequently the boundaries of penal law, to expose the inefficacy, as well as injustice, of many provisions in the judicial code of his own country, and in those of other European nations; and which, derived from remote times, and established under a different order of society, had been perverted and debased during successive ages of barbarism. The authority of positive institutions formed almost the only basis of law, even in countries the farthest advanced in civilization; and that authority was in many of them drawn too servilely from the Roman system. Montesquieu had already thrown many penetrating glances at the foundation and structure of these ancient fabrics; but it was still reserved for others to scrutinize them more closely, and to draw forth, and present to general view, those direct inferences which that examination suggested. In no part were the existing codes more defective and vicious, than in the department of the criminal law; and it was to this, accordingly, that Beccaria's attention was exclusively directed. Nor does he offer the work as a general system, or theory, even of penal law; in which light it would be found every way imperfect; but only as an attempt to analyze parts of a system which he found actually existing. Among the most prominent of those points to which his reasoning is applied, are, the due proportion between crime and punishment, and the violations of that proportion, whether by unnecessary severity of punishments, or the want of a scale and distribution of them suited to the amount and danger of particular offences—the inconsistency of certain rules then established on the subject of legal Evidence—Secret Accusations—Fictitious Crimes—the use of Torture as an instrument for the discovery of truth—Imprisonment not authorized by law, or of uncertain duration—and the sale of offices of justice, along with other vices in the constitution of the courts. In treating these various topics, he seldom deduces his argument from remote sources, or pursues it to refinements. That some propositions are advanced in the course of the work, which are of a questionable nature, cannot be denied; and there are particular illustrations which have an exclusive reference to certain forms of government then existing in the Italian states. But, in general, the author reasons on few and acknowledged principles, and makes his appeal to the universal feelings

of mankind. As one of the most important conclusions which result from his reasoning, or rather as concentrating a number of these conclusions, he closes his book with the following proposition:—“In order that a punishment may not be an act of violence, of one, or of many, against an individual member of society, it is essential that it should be public, prompt, and necessary, the least possible in the given case, and determined by the law.”

His style, in this work, with exception of one or two passages, where he intentionally addresses himself only to the lesser number, is uniformly perspicuous, and, like that of all his other writings, though often eloquent, is unadorned. He employs, in some parts of it, that species of ridicule which, on a similar occasion, had been used with so great effect by Montesquieu. Thus, while treating the subject of Torture, he proposes, among others, the following query, in the form of a mathematical problem: “The force of the muscles, and the sensibility of the nerves, of an innocent person being given, it is required to find the degree of pain necessary to make him confess himself guilty of a given crime?” Peculiar traits are to be found, likewise, in other passages, of the writer's dispositions and train of sentiment. Thus having, in a later edition, modified, under that part which relates to Fraudulent Bankruptcy, some sentiments which he had originally expressed, but which, on reflection, appeared to himself too severe, he adds, in a note, “I am ashamed of what I formerly wrote on this subject. I have been accused of irreligion, without deserving it; I have been accused of disaffection to the government, and deserved it as little; I was guilty of a real attack upon the rights of humanity, and I have been reproached by nobody.”

If many of the views exhibited in this work are now divested of novelty; and if, through the general adoption of them by the most cultivated nations, we are led to forget that they were once hidden, or excluded, such is the fate of all improvement, as well as of all discovery. Nor does it detract from the true character of this interesting performance, that in some enlightened countries, and in the more propitious climates of political liberty, many of the important doctrines which it inculcated were already recognised in the systems of the law.† Beccaria was among the first by whom these principles were publicly avowed, under a government in whose institutions they had no place, and over whose judicial administration they exercised no influence; and, when the age and country in which he wrote are considered, the boldness of his statements is not less to be admired than the justness of his reasoning. It is his honourable distinction, likewise, and that of

Beccaria.

* These particulars, communicated in a letter of Count A. Verri to the Abbate Isidoro Bianchi, in 1802, are repeated by the latter in his *Elogio* on Pietro Verri.

† In the most favoured countries of liberty, however, the reception of some of these principles had been comparatively recent. Of others, the establishment seems even yet to be remote.

That work which has tended most to diffuse a knowledge of the progress and spirit of the English laws, viz. the *Commentaries* of Sir William Blackstone, was not published till the close of the year 1765; although his plan of delivering a public lecture on the judicial system of his country was formed in 1758. The professorship at Oxford, which gave full effect to that plan, was instituted by Mr Viner, in 1758.

Beccaria. the friends who shared his labours and his views, to have preserved, in the prosecution of those objects, an unblemished loyalty towards their prince; and, while combating, with manly perseverance, the errors which prevailed in fundamental principles of the legislation, to have abstained from all attacks which might either directly weaken the authority of the laws, or disturb the administration of the government.

According to the just exposition given by the author himself, the true tendency of such a work is not to lessen the power of the law, but to increase its influence, inasmuch as opinion has a greater command over the minds of men than force. It has frequently been repeated, indeed, that national manners must precede laws; and, in the only allowable sense of that maxim, the same might be said, perhaps, with equal truth, of opinions. But the authority of this *dictum*, and the extent to which it may be followed, are not unfrequently mistaken. An important distinction is apt to be overlooked, between those general laws, which, as they are founded in permanent principles of our nature, admit of being drawn from the first springs, but which have been disturbed by ignorance, or a barbarous policy, or the temporary dominion of some prevailing passion—and those artificial or secondary arrangements, which the circumstances and stages of political society may equally render necessary in times of knowledge, and tranquillity, and civilization. It is to the latter class only that the maxim referred to can have any just application. But it may well be questioned, whether, in any case whatever, the popular feeling and opinion should be allowed to precede, by any considerable interval, the act of the legislature. It seems, on the contrary, to be a valuable secret in legislation, and one of its most important ends, to seize the proper moment for accomplishing that union. Above all, it is expedient, in those branches of the law, which are interwoven with, and derive their support from, the moral feelings, that a legislator should seek to anticipate every better tendency of public sentiment. Through want of a well-timed interference in such cases, many advantages are relinquished, as well in the concoction and frame of the laws themselves, as in that silent influence, which a well directed system of jurisprudence carries into the opinions and habits of a community.

Of the prospects which Beccaria himself entertained as to the probable influence of his work, a judgment may be formed from the sentence of Lord Bacon, which he prefixed to some of the editions. "It is not to be expected in any difficult undertaking, of whatever kind, that the same person who sows the seed should also reap the harvest; but there must, of necessity, be a preparation, and gradual progress to maturity."

The book was received in foreign countries with avidity, and procured for its author an immediate and high reputation. "Never," says a writer in the *Biographie Universelle*, "did so small a book produce so great an effect." The medal given by the Academy of Bern was instantly bestowed upon Beccaria; and the Empress Catherine II. invited him to St Petersburg, with the offer of an honourable sta-

tion at her court; a proposal which was partly the means of procuring him a similar distinction at home. Of the reception which the work obtained in France, particularly among the literary societies of Paris, evidence is afforded by the correspondence of the Baron de Grimm. "This book," he writes in a letter, dated 1st August 1765, is by M. Beccaria, a Milanese gentleman, who is said by some to be an Abbé, by others a lawyer, but who, I answer for it, is one of the best heads at this moment in Europe." "You will not find in the Milanese philosopher," he elsewhere observes, "either the pitch or compass of genius which characterize the writings of the President Montesquieu; but you will discover a mind that is luminous, profound, correct, and penetrating." And he justly adds, that his is one of the few precious books *qui font penser*. It was translated into French by the Abbé Morellet in 1766; and Voltaire, soon after, published a commentary upon it, under the assumed title of *un Avocat de Besançon*. With respect to the former production, the translator took some liberties with the method and distribution of the work, which were not altogether warrantable. Voltaire's commentary is written in the light style peculiar to him; and was, evidently, intended as a vehicle for certain opinions of his own, with which the spirit and object of the original publication are entirely unconnected. But the circumstance itself sufficiently marks the impression which that publication had made, and the prominence of the views which it developed. It was rapidly translated into various other languages; its maxims became a species of current coin through a great part of Europe; and the sanction of the author's reasoning was thought not unworthy of being resorted to in British tribunals.

Although followed by many others, Beccaria's was the first work of note, in which the application of a milder and more sound system of penal jurisprudence was explicitly enforced. Nor would it be at all extravagant to refer some of the great improvements, which, from this era, were successively introduced into the written laws of different European monarchies, to the direct influence of the opinions thus generally diffused. Many such enactments, at least, were, from this time, promulgated in a tone more consonant than heretofore with the dictates of humanity and equitable rule. Of this description were, among others, not only the *urbarium*, or regulations concerning villanage, issued in 1764, by the Empress Maria Teresa, but also the more extended designs which took effect, at a somewhat later period, in the various reformed codes, published by the Empress Catherine, the Emperor Joseph II., the Grand Duke of Tuscany, and the Danish Government under the administration of the late Count Bernstorff.

At one period, a storm seemed to be preparing against the Marquis in his own country, by those who probably intended, in this form, a service to the government: but it was soon dispersed by the authority of the government itself. Beccaria had considered it his duty to communicate to Count Firmiani the offers which had been made to him by the Empress Catherine; and the intelligence was trans-

Beccaria.

Beccaria. mitted by the viceroy to his own court. The conduct of Prince Kaunitz-Ritsberg, on the occasion, is highly honourable to that minister, and to his sovereign. Instead of treating the communication as a matter of no account, he makes it the subject of a long dispatch, and of repeated instructions. In one of these papers, dated 27th April 1767, after requiring particular information respecting the personal character of Beccaria, he adds, "Supposing his good qualities to preponderate, it would be desirable that the country should not lose a man whose fund of knowledge is so considerable, and who, as appears from his book, possesses a mind habituated to reflection, above all, in our present penury of thinking and philosophical men; besides that it would do little honour to the whole administration, to be anticipated by foreigners in the due estimation of talents."* Nor were these merely empty professions; but were almost immediately followed by an imperial order, for establishing, in the Palatine College at Milan, a Professorship of Public Law and Economics, under the title of *Scienze Camerali*. To this chair, expressly endowed for him, by a distinction so honourable, the Marquis was appointed on the 1st of November 1768, and commenced the duties of it in the month of January following. From the preliminary discourse (*prolusione*) which he pronounced on this occasion, and in which he briefly sets forth the objects of the institution, and some of his own leading opinions regarding them, it appears that the only instructions which he received from the regency, on his appointment, consisted in an order to deliver his discourses in the vulgar tongue; an injunction of which the motives are so honourable to that government, in common with all the circumstances attending this transaction. His lectures, which he received a special permission to deliver in his own house, attracted much notice. They were not published during his life; but have since appeared, under the title of *Elementi di Economia Pubblica*, in the compilation of the *Scrittori Classici Italiani di Economia Politica*, printed at Milan. †

As he had, in his former work, set out with stating the object of municipal law to be "the greatest happiness of the greatest number," so here the same universal principle serves him for a guide; and he

Beccaria. assumes it as the aim of public economy "to provide, with peace and safety, things necessary and convenient for the whole community." He classes the objects of Political Economy under five heads; Agriculture, Manufactures, Commerce, Finance, and Policy; comprehending, under the latter, those laws and institutions which have a respect to the Sciences, to Education, to Police, in the modern sense of that word, and to the various means of Public Defence and Security. The design was not completed; no trace, at least, appears in the work published under the above title, relative to the subjects of Finance or Public Policy. ‡ In estimating the value of these speculations, it is no less necessary, than in the case of the former work, to consider them with a reference to the state of science at the time, rather than to the present extension of knowledge in this department. Under the first three divisions, he enters at considerable length into some of the most interesting discussions which have arisen in this wide field; particularly as to the principles of public policy in regard to Agriculture, to the Commerce of Grain and Foreign Commerce generally, and to Money and Exchange. § In perspicuity of language, and distinct and patient illustration, the style of these discourses bears a considerable resemblance to that of the *Wealth of Nations*; but the coincidence between the two works, in some general and fundamental doctrines, is still more remarkable and interesting. Beccaria does not appear to have adopted the particular theory of the French Economists, which was developed about that time; although his practical doctrines on some of the most important points were conformable to the conclusions afforded by that system. ||

Among other inferences, to which the course of his reasoning leads him, as it were by many different roads, may be noticed one, which he has himself ventured to state as a general proposition; and which marks the caution as well as enlargement of his mind, in subjects of complicated inquiry. "Every restriction on freedom," he observes, "whether in the case of Commerce, or any other, ought to be a result from the necessity of preventing an actual disorder, not the effect of a purpose or aim at amelioration." And he has repeated the same doctrine under different views, in various other passages. ¶

* The originals of these dispatches are among the state papers in the public archives of Milan.

† The editor states that this publication was made from a copy of the discourses, transcribed for the author himself, when he visited Paris in 1776.

‡ Some of the others, too, are treated rather briefly. He has, himself, defended this method of teaching by the following just and striking observations, in that part of the work where he discourses of *Interest*: "But woe to the teacher who would say all that is to be said, and leave nothing to the penetration of the learner. What is heard slips away and vanishes from the hearer's mind, unless he has an opportunity of opposing the reaction as it were, of his own intellect, to the impressions of his instructor; and more light is thrown upon a science by one process of exact reasoning which we carry on for ourselves, and it is more deeply and firmly rooted in us by that single operation, than by many and repeated trains of reasoning conducted by another."

§ Under the head of Agriculture, he proposes the scheme of an Experimental Farm to be carried on at the public expence, as a school of that science, and enters into some detail of its objects and regulations.

|| Mirabeau's *Tableau Economique* had already appeared in the publication entitled *La Philosophie Rurale*; as well as various papers of Quesnai.

¶ For example, "The operations of Economics amount only to not permitting, and most frequently to letting alone."

Beccaria. On all these subjects, he exercises, without ostentation, the privilege of examining and judging for himself; and in doing so, although he expresses himself with plainness and energy,* he is never dogmatical. He observes this further dictate of a sound philosophy, to refrain as long as possible from any very general conclusions; and, although he appears to have disengaged his mind from the power of common and hereditary notions respecting political economy, he does not, by a transition too often made, substitute dangerous or extravagant positions in their place. He is even more distinguished by the temperate use which he makes of his liberty, than by the independence which secured him from the chain.

During the same period in which he pursued these labours, Beccaria undertook another literary task of a very different description; and commenced an *Inquiry into the Nature of Style*. † A first part of this *Inquiry* was published in 1770; but the author does not appear to have prosecuted his intention; and only one detached portion of the remainder was found among his papers. ‡ The apology which he makes for this apparent deviation from his usual objects of pursuit, drawn from a consideration of the connection subsisting between the study of the fine arts, and that of moral and political science, affords a pleasing proof of the natural expansiveness of his mind. §

His scientific and literary studies were now to be interrupted, however, by new and more flattering marks of distinction from his government. By an imperial order of the 29th April 1771, he was appointed a member of the Supreme Economic Council; on the suppression of which, he was transferred to the Magistracy of State; and, lastly, by a despatch of the 17th January 1791, was named one of the Board for Reform of the Judicial Code, civil and criminal. His activity and usefulness in the discharge of these great trusts are best proved by the circumstance, that some of the most important matters in those different departments were committed to his direction, and regulated by his counsels. The most remarkable of his state papers were, various *Ordinances* relative to the grain; a very important *Despatch* transmitted to the Court in 1771, which gave rise to the reform of the public money in 1778; a *Plan* proposed in 1780, for effecting an uniformity in the weights and measures; and certain *Proposals*, in 1786, founded on the tables of the population. His writings of this description are characterized by their method, perspicuity, and precision. It deserves to be noticed, respecting his scheme for the equali-

zation of measures, that, of the different natural bases for exact measurement, he explicitly recommends that which may be obtained from the celestial bodies; and, in the application of it, proposes to employ the decimal method of division; being the same system which was afterwards adopted by the late Government of France. ||

In the year 1776, Beccaria made a journey to France, in company with his friend Alessandro Verri. He remained at Paris for about three weeks, which he passed chiefly in the society of D'Alembert, and other eminent men of letters; and, on his return, he visited Voltaire. This journey seems to have been the only considerable incident which, during a period of twenty-five years, diversified his manner of life, or interrupted his official duties. He died of apoplexy, in the year 1793. According to the editor of his *Elementi*, in 1804, his death was unnoticed by his country, and his tomb remained without a name.

Beccaria was twice married. He was steadfast in his friendships; modest, but tenacious of his opinions. He took pleasure in the society of literary men, and avoided that of the great. It is related of him, that the King of Naples, while at Milan, twice attempted to visit him at his house; but that the Marquis found means, on both occasions, to escape the honour intended for him by his Majesty. His exertions in the service of the public, and, above all, his earnest endeavours to promote, by every means, the cause of science, and a liberal system of education, formed the chief feature of his life. On the latter topic, he has made many forcible and eloquent appeals, in the course of his different writings; and some passages of this description, which are interspersed in his discourses of Political Economy, are not less to be admired for their intrinsic excellence, than they are interesting from the circumstances in which they were written, and the contrasts which they indirectly exhibit.

One trait of his constitutional disposition, or confirmed habit, has been recorded, as furnishing a remarkable exception to the general vigour of his intellectual character; that, notwithstanding the force with which he combated the prejudices and unreasonable apprehensions of other men, he was himself subject, when left alone, to an unconquerable timidity. We are not told whether this tendency was ascribed to early habits and a faulty education, or supposed to be the consequence of some sudden and fatal impression, which remained indissolubly associated with certain outward circumstances, or in what other manner it was formed and perpetuated. On a superficial view, it seems to denote a mind radically

* "Con un non fanatico vigore," as he has himself somewhere expressed it. But on occasions where he conceived that there might be a danger of inflaming the passions, he has claimed the tribute due to him for employing a style, "beyond the reach of the uninformed and impatient multitude."

† *Ricerche intorno alla Natura della Stile*.

‡ This additional chapter is given in the edition printed at Milan in 1809.

§ In no part of his writings is the enlargement of his comprehension, as well as soundness of his judgment, more to be remarked, than in the *Treatise* on the State of the Currency, which was his first publication, and written at the age of twenty-seven.

|| In the mathematical calculations connected with this subject, he was assisted, as he himself states, by Frisi, Professor of Mathematics at Pisa; and in the mechanical part by his brother Annibale.

Beccaria. weak. But this is not a necessary or a just inference. The fact is, indeed, singular, and deeply impressive; but, in truth, it only serves as a new example to prove how mixed is the nature of our frame; how imperfectly the understanding acts upon the will, and the will upon the mortal part; how many things appear to be within the jurisdiction of our reason, which, nevertheless, are superior to its control.

This is not the place to engage in a more particular examination of the spirit and scope of Beccaria's writings. He is said to have expressed, at least during the early part of his life, too unqualified an approbation of the works of Helvetius, and others belonging to the same school of philosophy. On this score, some excuse may, perhaps, be found for him in the attractions which the style of the author now mentioned possesses for a youthful and ardent mind. It is to be observed, likewise, that, when he expressed this admiration for the productions alluded to, the *Système de la Nature* had not yet made its appearance. Nor is it to be supposed that he could be insensible to the notice, and the applause, of such men as then held the stations of greatest eminence in the scientific world. Yet, whatever temptations he may have been exposed to from the influence of some of his literary associates, it is consolatory to reflect, that, neither in the works which he himself gave to the public, nor in those which have been brought to light since his death, are sentiments to be found which have a tendency to subvert any one foundation of private or of public good. His labours were beneficent, and their natural fruits, the dissemination of useful knowledge, the increase of industry, and the improvement of social order. But he was not to witness the spectacle which ensued, or to be an observer of that moral crisis, of the results of which it may be questioned, if, hitherto, they have less disturbed the calculations of the friends of humanity, than baffled the counsels of its foes.

Some farther information, with respect to Beccaria's publications, will be found in the *Notizie*, prefixed to his *Economia Pubblica* (*Scrittori Classici Italiani*, Tom. XI.); in the 4th volume of the *Biographie Universelle*, printed at Paris in 1811, and in the 4th and 5th volumes of the *Correspondance par le Baron de Grimm*. In the compilation first mentioned are contained (besides his *Elementi*), republishments of his *Relazione della Riduzione delle Misure di lunghezza all' Uniformità, per lo stato di Milano*; of his *Prolusione letta nell' apertura della nuovo cattedra de scienze camerali*; and of his inquiry *Del Disordine e De' Rimedi delle Monete*. In the same collection is likewise to be found a paper written by him for the periodical work called *Il Caffè*; viz. *Tentativo Analitico sui Contrabbandi*, being an attempt to apply the algebraical method to certain subjects of political economy. A new edition of Morellet's French translation of the *Treatise on Crimes and Punishments* was published by M. Roederer in 1797; and a version of the same treatise into modern Greek, by Coray, was published at Paris in 1802. (EE.)

BECCARIA (GIAMBATTISTA), a very ingenious and industrious electrician and practical astronomer, was born at Mendovi, the 2d of October 1716,

and entered the religious order of the Pious Schools in 1732. He became a professor of experimental physics, first at Palermo, and then at Rome, and was appointed to the same situation at Turin in 1748: he was afterwards made tutor to the young Princes de Chablais and de Carignan, and continued to reside principally at Turin for the remainder of his life. In May 1755, he was elected a Fellow of the Royal Society of London, to which he afterwards communicated several papers, relating to his favourite pursuits. He died 27th May 1781.

1. The most voluminous and most important of his works, entitled *Dell' Eletticismo Artificiale e Naturali*, appeared at Turin, 1753, 4to; and was reprinted in 1772. It was translated into English, and published, with the original engravings, under the title of *A Treatise upon Artificial Electricity, and an Essay on the Mild and Slow Electricity of the Atmosphere*. 4. Lond. 1771.

2. *Risposta ad una Lettera intorno al suo Eletticismo*. 4. Milan, 1753.

3. *Lettere dell' Eletticismo Atmosferico* Ed. 2. 4. Turin, 1758.

4. *Experimenta et Observationes quibus Electricitas vindex late constituitur atque explicatur*. 4. Graz.

The accurate and elaborate experiments, related in these works, have obtained for their author the warm and repeated encomiums of the scientific historian Dr Priestley, and the approbation and friendship of other contemporary philosophers; although it must be confessed, that amidst the multitude of important facts recorded in them, we sometimes observe a want of clearness of arrangement and closeness of reasoning; nor must we attempt to claim for Beccaria either the originality of a Franklin, the mathematical precision of an Æpinus, the enlarged views of a Cavendish, or the neatness and inventive talent of a Volta. The most remarkable novelties, which deserve to be distinguished among our author's experiments and opinions, relate to the limited conducting power of water, to the electrification of the air and smoke, to the velocity of electricity, to the reduction of metals by its powers, to the illumination of the solar phosphori by the spark, to the light excited by the motion of the air, and to a variety of meteorological phenomena, especially lightning, storms, rain, water-spouts, and atmospherical magnetism. The resistance exhibited by water to the passage of the electric fluid is demonstrated by the luminous appearance of its path, while it passes through more perfect conductors without producing light; as well as by the explosion of glass tubes containing water, through which the spark is taken; and this experiment is extended to the construction of an electrical water gun, which is said to have carried a small bullet with considerable force.

Father Beccaria observed, about the same time with Mr Canton, that the air surrounding an electrified body was capable of becoming electric by slow degrees, and that it also parted slowly with its electricity; and, by means of some property of this kind, he produced the appearance of a luminous atmosphere about an electrified ball, to which another was presented, in a partial vacuum. The smoke of

Beccaria. colophony, surrounding an electrified body, enabled it to give longer sparks, but this smoke was little attracted by the body when the heated spoon containing the colophony was insulated. Respecting the velocity of electricity, he relates some experiments, which amply deserve to be confirmed or confuted. He found the effect of a spark occupy at least half a second in passing through 500 feet of wire, and $6\frac{1}{2}$ through a hempen cord of the same length, although, when the cord was wetted, it passed through it in 2 or 3 seconds. It is well known, that, in the earlier experiments of Watson, a shock was transmitted through a much longer circuit of wire, without occupying any perceptible interval of time in its passage. Many of the metals were revived from their oxyds, and mercury was reproduced from cinnabar by the powers of electricity; and our author fancied that he had discovered a common principle in the different metals, as several of them gave the same colour to the surface of the glass to which they were attached. The brilliancy of the electric light was demonstrated by the permanency of its effect on the solar phosphori; and this subject was afterwards pursued by various experiments of Canton, and others. The light often exhibited by the air rushing into a vacuum, is attributed by Beccaria to the friction of the air against the sides of the glass. It may be remarked, that the phenomenon is, in all probability, of the same kind as the appearance of light observed long ago in the air-gun by its first inventor, Ctesibius of Alexandria. With respect to atmospherical electricity, Beccaria's researches were most laborious and extensive, and he made a great variety of experiments illustrative of the nature of lightning, and of storms in general; showing, for instance, the facility with which small bodies are forced into the course of the electric current, as light clouds are made to assist in conveying a stroke of lightning, and proving that evaporation, and the deposition of vapour, are always accompanied by electrical changes. Thunder-storms, in general, he attributes to terrestrial electricity, and supposes the clouds to be merely the channels by which the fluid is carried from one part of the earth's surface to another, the equilibrium having been first disturbed by chemical changes within the earth; and it must be confessed, that this opinion is, in some measure, encouraged by the frequent connection which is observable between these phenomena, and those of earthquakes and volcanic eruptions. Water-spouts, he assures us, on the authority of several eye-witnesses, may certainly be dispersed by pointing swords and knives at them; and, with respect to conductors erected for safety, though he appreciates their utility very highly, he thinks that every large building should be furnished with more than one or two. The *electricitas vindex*, so often mentioned, is the electricity made sensible in one body by the removal of another which has been situated near it,—a property which afterwards led to the elegant inventions of the electrophorus and the condenser of Wilke and Volta. Our author appears to be somewhat disposed to exaggerate the importance of electrical changes as the causes of other atmospherical phenomena, and, in particular, to overrate the intimacy of the connection of electricity with magne-

tism. The appearance of the *aurora borealis* he attributes to the circulation of electricity through the higher regions of the atmosphere, and he was well aware of the magnetical changes which usually accompany this remarkable occurrence.

5. His papers in the *Philosophical Transactions* are all in Latin. The first is entitled, *Experiments in Electricity, in a Letter to Dr Franklin*. (*Ph. Tr.* 1760, p. 514.) These experiments relate principally to the subject of electrical attractions and repulsions, which the author attempts to reduce to the effect of currents of air displaced by the immediate action of the electric fluid. He supposes the air between two bodies, in dissimilar states, to be rarefied by the interchange of their electricity, so as to produce the appearance of attraction; and when the bodies are in similar states, he imagines the air interposed to be the immediate object of their apparently mutual repulsion. The paper is accompanied by a note of Dr Franklin, explanatory of the apparatus employed.

6. *An Account of the double Refractions in Crystals*. (*Phil. Trans.* 1762, p. 486.) The double refraction of rock-crystal had been observed by Huygens. Beccaria seems to have imagined, that it was not discoverable when the surfaces concerned were parallel to each other; but later observations have shown, that his observations were defective in this respect, at the same time that they have confirmed his conjecture respecting the existence of a similar property in almost all crystallized substances.

7. *Novorum quorundam in re Electrica Experimentorum Specimen*. (*Phil. Trans.* 1766, p. 105.) In this paper, our author defends the simpler theory of Franklin against Mr Symmer's doctrine of the existence of two separate electric fluids. He also enumerates a great variety of cases of the excitement of positive or negative electricity by the friction of different substances with glass, hareskin, a silk stocking, sealing-wax, and sulphur.

8. A second paper, with the same title, appeared in the *Philosophical Transactions* for 1767, p. 297. It contains an account of a repetition of experiments on the modification produced in the charge of two or more glass plates, by separating them, and by removing and replacing their coatings. These investigations were principally suggested by the well-known observations of the Jesuits, made at Pekin many years before, and by some subsequent experiments of Mr Symmer. The author calls the effect an oscillation of electricity; it depends on the same causes as the "vindicating electricity," which he has elsewhere described.

9. *De Atmosphæra Electrica libellus*. (*Philosophical Transactions*, 1770, p. 277.) The phenomena of induced electricity are here discussed, but not with great precision; the author adverts, however, to the Newtonian demonstration of the equilibrium of the force of a gravitating substance, distributed through the surface of a sphere, with respect to a particle within it, and gives somewhat clearer views of the theory of electricity than his former works had exhibited, but still falls far short of the perfection which Æpinus had attained more than ten years before.

10. A short *Letter to Mr John Canton, on his new*

Beccaria.

Beccaria
Beckmann.

phosphorus receiving several colours, and only emitting the same, is printed in the *Philosophical Transactions* for 1771, p. 212. Our author admitted the sun's light through green, red, and yellow glass, and found that the pieces of sulfureted lime exposed to it, emitted only a light similar to that which had been thrown on them. A multiplicity of later experiments have however shown, that the contrary result is by far the most common; and Zannotti's earlier observations have been fully confirmed by Wilson, Grosser, and Seebeck.

11. In 1759, Beccaria received orders from his sovereign, in consequence of a suggestion of Boscovich, to measure the length of a degree of the meridian in the immediate neighbourhood of Turin; the measurement was completed in 1768, and an account of it was published under the title of *Gradus Taurinensis*, 4. Turin, 1774; prefaced by a proper compliment to the memory of the monarch who patronised the undertaking, and to the virtues of his successors, under whose auspices it was completed. The result did not, however, exhibit the appearance of any great accuracy or good fortune, for there is not only a difference of one-seventieth of the whole in the lengths of the degree computed from the northern and southern portions of the arc, of 27' and 41' respectively, but the length deduced from the whole arc, which is 57468.59 French toises, is 445 toises more than would be inferred from other measurements in the neighbouring latitudes: hence it appears to have been thought necessary by later astronomers to reject the northern portion altogether, and to make some corrections in the calculation from the southern, by which the length of the degree has been reduced to 57069 toises. The Zenith sector employed for the observations was made on Boscovich's construction, the length of the tangent being measured instead of that of the arc, a method by no means calculated to lessen the chances of error. A portable syphon barometer is also described, by means of which the elevations were ascertained; and a number of heights of places in the mountains of Piedmont are recorded.

12. This volume appears to have been the last of Beccaria's publications: An *Essay on Storms and Tempests* is mentioned, without approbation, in the *Dictionnaire Historique*, but it was probably extracted from some of his other works. In his private history and adventures there appears to have been little for a biographer to relate; his ambition having been in great measure limited, by the religious profession which he had adopted, to the acquirement of literary celebrity, his taste was guided by his prevailing pursuits. His only luxuries consisted in his library and instruments; and on these he expended a considerable part of the remuneration which he received, as a recompense for his services to the public, and to his royal pupils. (A. M.)

BECKMANN (JOHN), during nearly forty-five years Professor at Göttingen, was born at Hoyer, in the electorate of Hanover, in 1739. His father, who was receiver of taxes, and postmaster in this town, occupied himself in the cultivation of a small piece of land, and appears to have inspired his son with a taste for agriculture. However, all the honour of

his education belongs to his mother, who, having become a widow when young Beckmann was hardly seven years old, sent him, in his fifteenth year, to the school at Stade, placing him under the care of Gehlen. Being intended for the clerical function, he repaired in 1759 to Göttingen, to finish his studies there; but whether the advice of Hollmann, who testified much kindness towards him, produced a change in his plans; or that the instructions of the mathematicians, Kaestner and Tobias Mayer, had greater attractions for him than theology, he abandoned the career on which he had entered, in order to devote himself entirely to the natural sciences, and principally to the application of these sciences to economical purposes. His first studies were not without their use to him; he derived from them a methodical habit of mind, and a considerable knowledge of languages, which, in the sequel, assisted him greatly in the pursuits to which he owed his celebrity. In 1762, having lost his mother, and with her his former means of subsistence, he accepted the offer of Busching, who invited him to come and fill the situation of Professor of Natural Philosophy in the Lutheran Academy at St Petersburg, of which this celebrated geographer had at that time the direction; but Busching quitting the institution shortly after, and dissensions having arisen among the superintendents, Beckmann gave up his place, and made a journey through Sweden to acquire a detailed knowledge of the mines of this country, and of the manner of working them. Linnæus having received him hospitably at Upsal, he prolonged his stay there, and availed himself of the friendship as well as the instructions of this naturalist. In 1766, the governors of the University of Göttingen appointed him, on the recommendation of Busching, Professor to this celebrated establishment, of which he became one of the principal ornaments. His mind, entirely directed to the practical uses of human knowledge, had early conceived the idea of an academical classification of the arts and different branches of economy, both political and domestic, which had hitherto been left to routine and accident. He composed, to serve him as a guide in this course of instruction, *Treatises on Rural Economy—On Policy—On Finance—On Commerce*, and other departments of practical knowledge; which, though since carried to a higher degree of perfection, owed to Beckmann their first elements, and their first scientific form. His *Lectures*, which had at the time the recommendation of novelty, were attended by the flower of the studious youth, whom the most civilized nations of Europe sent to the University of Göttingen; and it may be added, that the most distinguished statesmen and public functionaries of Germany were among his auditors. He was in the habit of accompanying them himself into the workshops, to give them a knowledge of the different processes and handicrafts, of which he had explained to them the theory. He never relinquished his public lectures; but his private studies took insensibly a direction altogether historical, the motives for which it will not be uninteresting to point out.

It is considered at Göttingen, that a Professor

Beckmann. cannot be excused from explaining the progress of the science, which he teaches, in all the civilized nations of Europe at the same time. Any one, who, two years after the appearance of a work of importance in his department, published in any country of Europe whatsoever, should not have read and analyzed it in order to refute or else enrich his own observations from it, would not regard himself as a worthy successor to the chair of Haller, of Mosheim, of Gessner, and Michaelis. Beckmann in particular, having studied at Göttingen at a time when the example of these great men dictated the law and gave the tone there, was determined to advance in a line with his age, and not to be ignorant of any of the steps which were making by the numerous and extensive sciences which furnished the foundation and the subjects of these practical principles. But these steps were the steps of a giant; and whatever might be his ardour, or his love of study, how could he be supposed to read and judge of all the important works which appeared from the year 1770, on chemistry theoretical and practical, on physics, natural history, and mathematics? His disappointment ended in chagrin, and gave him a degree of anger against the new ideas, methods of reasoning, and materials, which changed the face, enlarged the limits, and facilitated the study of these sciences. His course of lectures, turning only on practical matters, suffered little from this circumstance; but feeling that his writings would be accused of remaining behind the progress of the sciences which were the subject of them, he directed the researches with which he wished to occupy the attention of the public to the history of arts and trades, and employed, in the illustration of this subject, the materials to which he had access in the Göttingen library, assisted by general information, a mind peculiarly fitted for this kind of study, and by indefatigable industry. It is to these labours that we owe the *Notices* of Beckmann on the history of discoveries in the most common arts of life; for instance, the history of watch-making, of distillation, of almanacs, of insurance, of the lighting of streets, of the original country and migrations of the fruits and flowers in our gardens, of the common materials for dyeing, of bellows, of fire-arms, of mills, of grinding corn, of carriages, of different parts of our dress, of different household utensils, of a multitude of machines and mechanical contrivances employed in common trades, and of most of the products of industry; such as the gathering of saffron, the preparation of alum, the printing-press, of fulling-mills, of book-keeping, of the digging of turf, of gazettes and newspapers, of stamped paper, of the pearl-fishery, of pavings, of chimneys, of collections of natural curiosities, of milestones, of pharmacy, of quarantine, of painted paper, of ruffles, of milking, of pawn-brokers, of looking-glasses and glass in general, of soap, of musical-glasses, of watchmen, of ices to eat, of the anatomy of plants, of exchange, of pens for writing, of instruments of husbandry, of fireworks, of the working of

pewter, of the procuring of amber, of indigo, of Beckmann-gilding, of weathercocks, of furs, of steel, of gardening, of crayons, of knives and forks, of corks, of sal-ammoniac, of hops, of weaving, of lotteries, of hospitals for orphans and foundlings, of infirmaries, of lazarettoes, of fighting-cocks, of saltpetre, of gunpowder, and aquafortis, &c. &c. We should form to ourselves a very false idea of these *Notices*, if we expected to find in them only some general account of these arts, and of the different manner of practising them, used in different times and places. Beckmann traces their first germ from the most remote periods of antiquity; he follows their developement through the obscurity of the middle ages; and exhibits their latest improvements amongst the civilized nations of modern Europe, with a patience and a depth of learning which can only be equalled by the sagacity and the variety of knowledge displayed in his researches. We have thought it would be interesting to the reader to see a list of the most remarkable among these notices, in the order in which they were published. They make five volumes in octavo, published at Leipsic from 1783 to 1805; and will furnish the most invaluable materials to the individual, or to any society of men of letters who may hereafter venture to undertake the general history of the origin and progress of the mechanic arts, which are so important a branch in that of civilization. It is almost needless to add, that the most exact references to original authorities accompany each article, and give it a new value in the eyes of those who are unwilling to take things upon trust, or may be desirous to push the inquiries of the author still farther.

The same merits belong to his *History of the earliest Voyages made in modern times*; a highly interesting collection, which occupied the last years of his life, and which he left at the eighth number. Another result of the literary application of the industry of Beckmann was a return to the studies of humanity, to which we are indebted for editions of the work *De Mirabilibus Auscultationibus*, attributed to Aristotle (1786); of the *Wonderful Histories* of Antigonus Carystius (1791); and of Marbodius's *Treatise on Stones* (1799);—editions which required the rare union of physical knowledge and sagacity with philological learning. The Royal Society of Göttingen had, in the year 1772, admitted him one of its members, and, from that period to 1783, Beckmann supplied their proceedings with interesting memoirs, among which are the following: *On the Reduction of Fossils to their Original Substances.*—*On the History of Alum.*—*On the Sap of Madder.*—*On the Froth of the Sea, from which the Heads are formed for the Nicotian Fistula.*—*On the History of Sugar.** But, from this period, he desisted all at once from partaking the labours of this learned body, probably from the same motives that we have assigned above for the change in the objects of his own particular studies. He was, besides, modest to an extreme degree; and his natural timidity did not find any thing to counteract it in the traditional jealousy of reputation, which the example of

* See *Novi Commentarii Soc. Sc. G. Tom. II.—VIII.* and *Commentar. Tom. I.—V.*

Beckmann his predecessors, who had founded the glory of Göttingen, had transmitted to a generation more confident of its powers, and more vain of its merit, but still restrained by habits difficult to lay aside, when the respect for great authorities had originally sanctioned them. His candour, his sincerity, his fidelity in friendship, his affability to his scholars, have been celebrated with one accord by his coadjutors and his auditors. Schlätzer, whom he had known from his youth in Russia, was the one among his colleagues with whom he maintained the most uninterrupted intimacy. He was better qualified than almost any one else, to appreciate the researches of Beckmann, as he had himself insisted with so much force on the necessity of introducing into history a view of the influence exercised on social institutions by the efforts of industry, and by the birth or maturity of the most common arts. Beckmann died the 3d of February 1811, after having been admitted into almost all the learned societies of Germany and the north, and after having impressed a tendency to pursuits of practical utility on the minds of a multitude of distinguished young men who had attended his lectures, and whom his celebrity drew to Göttingen during the forty-five years of his professorship. A portrait of him will be found at the head of the twelfth volume of the *Economical Encyclopedia* of Krunitz, and it has been engraved separately by Raid, Schwenterley, and Grape. Beckmann married the daughter of Hollmann, his tutor and friend; she survived him only a few weeks, and they left a son and daughter grown up. His eulogium was pronounced by his colleague, the illustrious Heyne, and was published at Göttingen, with this title: *Memoria Joan. Beckmann, Soc. R. Sci. Götting. sodalis in concessu Soc. Publico D. 16 Febr. 1811, commendata.* (z.)

BEDDOES (THOMAS), a physician of great eminence for his talents and philanthropy, was born at Shiffnall in Shropshire, on the 13th of April 1760, and was originally of Welsh extraction. He received the first rudiments of his education at a school in his native town, and afterwards at a seminary at Brood in Staffordshire. The strength of his intellectual powers was apparent at a very early period of his life: and he was remarkable from his infancy for his insatiable thirst for books, and for his indifference to the common objects of amusement, which usually captivate the attention of children: His rising abilities were discerned and justly appreciated by his grandfather; a man of great natural acuteness of mind, and who, by his industry and enterprise in trade, had acquired a considerable fortune. To this intelligent relation he was deeply indebted for many of the advantages of his early education, and for prevailing on his father (who, wishing to retain his son beneath the paternal roof, and train him up to business, was less anxious about his literary acquirements) to fix his destination for one of the learned professions. When he was only nine years old, the circumstance of an accident which befel his benefactor, and which, after being followed by some remarkable symptoms, terminated fatally, was calculated to make a deep and lasting impression on a mind like that of young Beddoes, and was sufficient to give it a decided direction. By the extraordi-

nary acuteness and interest which he manifested on this occasion, he attracted the notice of Mr Yonge, the surgeon who attended the sufferer; and a foundation was thus laid for the friendship which ever after subsisted between them, and which appears to have had a considerable influence in his choice of that profession, in which he was destined to run so brilliant a career. Under the tuition of the Reverend Mr Harding, at the Free Grammar School in Bridgnorth, he made rapid progress in classical learning; and was distinguished by his great fondness for reading, by his facility in acquiring knowledge, and by the possession of a memory surprisingly retentive, a faculty which he retained through life. When about thirteen years of age, he was placed as a pupil with the Reverend Mr Dickenson, Rector of Plymhill in Staffordshire, with whom he continued about two years, and who has given the following report of the zeal with which he pursued his studies. "During the period that Dr Beddoes was under my care," observes Mr Dickenson, "his mind was so intent upon literary pursuits, chiefly the attainment of classical learning, that I do not recollect his having devoted a single day, or even an hour, to diversions or frivolous amusements of any kind. His vacant hours were generally employed in reading Reviews, of which he had access to a very numerous collection." It is singular, that, in giving a sketch of his mental powers, though he describes his judgment as solid, he represents his genius as not "enlivened by any remarkable brilliance of fancy." We shall soon have occasion to observe how eminently he was afterwards gifted with the very quality, in which a near observer of his character pronounced him to have been at that time deficient. His moral conduct was ever irreproachable, and his docility and equanimity of temper were in the highest degree exemplary.

He continued the same habits of sedulous application, and retained the same independence and integrity of character at the university, to which he was removed on quitting Mr Dickenson. He entered at Pembroke College, Oxford, in Michaelmas term 1776. The simplicity of his appearance, and the rusticity of his manners and address, could not long conceal the superiority of his mental powers, which became more conspicuous by extended competition, and soon met with the respect and applause to which they had so high a claim. The themes and declamations of young Beddoes were remarkable for their elegant latinity; and he soon acquired distinguished reputation as a classical scholar. Success in one acquisition was to him but an inducement to the possession of another; and already versed in the ancient, he resolved to become master also of the modern languages. He was found one morning by a friend, who casually entered his apartment, very busily engaged with a French grammar and dictionary before him. On his inquiring what was the nature of his studies, Beddoes told him that he was only learning French. His friend expressed surprise that he should attempt it without a master. He replied, that it was unnecessary, and that he should conquer the difficulties of the language by himself in about two months. His friend

Beddoes. desisted from farther interference; but, noting in his own mind the date of his visit, called upon him again at the expiration of two months, and taking the opportunity of turning the conversation to the subject, inquired whether he had mastered the language. Beddoes answered in the affirmative, and proved his assertion by reading in English, with perfect fluency, and much to the astonishment of the hearer; a French book which the latter presented to him. From the French he proceeded to the Italian, which, from its analogy with the former, he acquired with great ease. The German language presented more serious difficulties; but his perseverance triumphed over them without the aid of any master. Not content with this, he afterwards added the Spanish language to his other acquisitions, as if determined to possess every avenue, by which useful or ornamental knowledge could possibly be attained.

Whatever time he may have devoted to general literature, while at the University, chemistry and the other sciences more closely connected with his future profession, were always his favourite objects of pursuit. The splendid discoveries of Black and Priestley, which had opened a new field of discovery, and promised to lead to the most important results, were powerfully calculated to inflame the ardour of so inquisitive and sanguine a spirit as that of Beddoes; and he accordingly soon became perfectly conversant with the new doctrines of pneumatic chemistry, and used to exhibit, with great delight, the experiments which supported them, to a circle of literary friends in Shropshire, during his vacations. He was also much occupied with mineralogy and botany; and for the former of these sciences, especially, retained throughout life a remarkable fondness.

Having taken his Bachelor's degree at one and twenty, he repaired to London, in order to commence the study of his profession, for which, as is well known, the English Universities do not provide the means. He became a pupil of the celebrated Sheldon, and devoted his time to the details of practical anatomy, and the physiological inquiries connected with it. It was while he was engaged in these studies, that he gave to the world, in 1784, a translation, from the Italian, of Spallanzani's *Dissertations on Natural History*; a work which, in the year 1790, went through a second edition. In the year following (1785), he published a translation of Bergman's *Essays on Elective Attractions* (the first work to which Beddoes affixed his name), accompanied by numerous original notes, which display an accurate acquaintance with all the modern improvements in the physical sciences. In 1786, he became again known to the public as the editor of Scheele's *Chemical Essays*. Previously to this, in 1783, he took his degree of Master of Arts; and, in the autumn of 1784, removed to Edinburgh, where he remained during three successive winters, and one summer. Shortly after his arrival, he became a member of the Medical Society, and of the Natural History Society of that place, and took an active part in the series of physiological experiments, in which some of the members of the former were, at that period, engaged: to the latter he contributed two papers, one on the

Sexual System of Linnæus, the other on the *Scale of Being*, both of which have been preserved at full length in Dr Stock's Memoirs of his life. The high estimation in which his talents were held at Edinburgh was shown, not only by his receiving every mark of honourable distinction from his fellow students, which it was in their power to confer, but also by their choosing him as the organ of their remonstrances with the Managers of the Infirmary, on the occasion of a misunderstanding which had arisen between them, as to the hours at which they should be permitted to attend; and they were eminently indebted to him for the firmness with which he, on that occasion, maintained their privileges.

After taking his degree of Doctor in Medicine at Oxford, in December 1786, he made, in the ensuing summer, an excursion into the Highlands, and also spent a short time at Paris and Dijon, where he cultivated the acquaintance of Lavoisier and Guyton de Morveau. Soon after his return, he was appointed to succeed Dr Austin, in the Chemical Lectureship at Oxford, an office which he was eminently qualified to fill. The success which attended his exertions to inspire a taste for scientific researches was soon apparent, in the full and generally overflowing audience attracted by his lectures, and by his communicating to most of his hearers a large portion of that enthusiasm for the pursuit of which he was himself possessed. Enjoying the reputation of distinguished talents, in a place where so much deference is paid by all ranks to the possessor of so noble a distinction, and surrounded by men of learning and abilities, who courted his society, his situation at the University appears to have been truly enviable; and it is difficult to understand the motives which could have led him to relinquish all these advantages, for the uncertain prospects afforded by his establishing himself in any other town. The decided part which he took in the political discussions that were agitated at the beginning of the French Revolution, seems to have had a principal share in this determination. His opinions, which it was no part of his character ever to conceal within his own breast, were, on this occasion, expressed with his usual freedom; and were of a nature to give offence to many of his former admirers; and the circulation of a political article which he inserted in a Shropshire paper, in reply to some misrepresentations which had previously been made, in an advertisement soliciting relief for the French emigrant clergy, excited a clamour against him, which accelerated his adoption of the step he had previously determined upon, that of resigning his Lectureship, and quitting Oxford.

During his connection with the University, he published, at the Clarendon press, in 1790, an analytical account of the writings of Mayow, under the title of *Chemical Experiments and Opinions, extracted from a Work published in the last Century*; in which he asserts the claims of that extraordinary man to the discovery of the principal facts on which the modern system of pneumatic chemistry is founded; discoveries which Mayow had achieved at a very early period of life, and which had failed, for upwards of a century, to attract any notice from

Beddoes. the philosophic world. In the *Philosophical Transactions* for 1791 and 1792, we also find three papers by Dr Beddoes, the one containing *Observations on the Affinity between Basaltes and Granite*, in which he rejects the common division of mountains into primary and secondary, and states some strong arguments in favour of the volcanic origin of both; the other giving *An Account of some Appearances attending the Conversion of Cast into Malleable Iron*, which he supposes to consist in its purification from oxygen, charcoal, and hydrogen, which escape, during the process, in the form of carbonic acid and carburetted hydrogen gases; and, in a paper which forms an appendix to the latter, he relates a variety of experiments which he had made, confirming this theory.

The uncertainty of his future destination, on his retiring from Oxford, does not appear to have interrupted his literary labours; for it was at this period that he published his *Observations on the Nature of Demonstrative Evidence, with an Explanation of Certain Difficulties occurring in the Elements of Geometry, and Reflections on Language*, 8vo, London, 1793. In this essay he contends, in opposition to the doctrines of the ontologists, and particularly to that of Mr Harris, the author of *Hermes*, that geometry is essentially founded in experiment; and that mathematical reasoning proceeds, at every step, upon the evidence of the senses; or, in other words, that this science is a science of experiment and observation, founded solely upon the induction of particular facts; as much so as mechanics, astronomy, optics, or chemistry. He endeavours to show that Euclid sets out from experiment, and appeals constantly to what we have already learned, or may immediately learn from the exercise of our senses. This paradox he attempts to support by a sophistical analysis of one of the elementary theorems in the first book of Euclid, and of the leading definitions and axioms prefixed to it. He is afterwards led to consider the origin of abstract terms, and the philosophy of language; and adopts on these subjects the views which have been presented by Mr Horne Tooke in his *Erra Proposita*; whose speculations, together with those of Lord Monboddo, Schultens, Hemsterhuis, and other Dutch etymologists, he severally reviews and criticises in an appendix of some length.

About the same period he published a work entitled *Observations on the Nature and Cure of Calculus, Sea-Scurvy, Consumption, Catarrh, and Fever; together with Conjectures upon several other Objects of Physiology and Pathology*. He there recommends, as a cheap and commodious remedy for calculus, the exsiccated carbonate of soda, made into pills with an equal weight of soap; in proof of the efficacy of which, he adduces a number of interesting cases. He then proceeds to develop his favourite pathological theories on the diseases which destroy so large a proportion of the human species; theories on which he afterwards built so many specious, but unfortunately abortive projects for their cure. Sea-scurvy and pulmonary consumption he conceived to arise from opposite chemical conditions of the body; the former consisting in a gradual abstraction, the latter in a gradual accumulation of oxygen in the system.

He supports these opinions by a variety of ingenious and plausible arguments; and proposes submitting them to the test of experiment, by administering to consumptive patients such gases as may contain a smaller proportion of oxygen than is contained in common atmospheric air. The new views of pathology which these speculations presented, and the hopes of valuable practical results which they raised, excited great attention in the medical world, and contributed much to increase the reputation of their author.

On leaving Oxford, he retired to the house of his friend Mr Reynolds of Ketley in Shropshire. It was here that he published his admirable *History of Isaac Jenkins*; a story intended to impress the most useful of moral lessons on the labouring classes, by exhibiting the reformation of a drunkard, and his return to habits of sobriety and industry. The execution of this work is worthy of the design. There is, probably, none of Dr Beddoes's productions which unites so many peculiar excellencies as this inimitable fiction, or which displays at once, in so favourable a light, the vigour of his genius, his deep knowledge of the human heart, and the power with which he could command the interest and sympathy of his reader. No work of its kind has ever had the same success; repeated editions, amounting to above forty thousand copies, were rapidly sold; and a large impression has since been issued at the request of a Society for promoting knowledge by the distribution of useful popular books.

A prospect now opened to him of realizing a scheme to which his wishes had for a long time been ardently directed, that of establishing a pneumatic institution, where the medical efficacy of the permanently elastic fluids, the fruits of the modern improvements in chemistry, could be fairly put to the test of experiment, by being administered on an extensive scale. The metropolis first suggested itself as an eligible spot for the formation of the projected establishment; but several obstacles having occurred in the execution of this plan, the neighbourhood of Bristol was at length fixed upon as the most proper place for the purpose. In making the various arrangements required in the infancy of such an institution, and which presented peculiar difficulties, he derived material assistance from the cordial co-operation of Mr Edgeworth, the author of *Practical Education*, with whose family he soon became more closely connected, by marrying one of that gentleman's daughters; an event which took place in April 1794. The pneumatic institution continued to occupy his attention for many years, in the course of which, a great number of publications issued from his pen, illustrating the principles on which he expected it to be useful, and detailing the experiments and the results to which it gave rise. The principal of these are the following: "*A Letter to Dr Darwin, on a new mode of treating Pulmonary Consumption*," in 1793; as a supplement to which appeared, in 1794, *Letters from Dr Withering, Dr Ewart, Dr Thornton, &c.* together with an analysis of a paper by Lavoisier, on the state of the air in crowded assemblies, and of another by Vauquelin, on the liver of the skate.—*Considerations on the Medical Use,*

Beddoes. *and on the Production of Factitious Airs*, in five parts, which came out successively at different periods, from the year 1794 to 1796.—In 1795, he published an *Outline of a Plan for determining the Medicinal Powers of Factitious Airs*.—In 1797, *Suggestions towards setting on foot the projected Establishment for Pneumatic Medicine: and Reports relating to Nitrous Acid*, in confirmation of the efficacy of that remedy in syphilitic affections.—In 1799, *Contributions to Medical and Physical Knowledge, collected principally from the West of England*.—*Notice of some Observations made at the Pneumatic Institution*.—A second, and afterwards a third *Collection of Reports relating to Nitrous Acid*. Considerable difficulty was at first experienced in the construction and management of the apparatus required for carrying on the objects of this institution; these were, however, in no long time entirely surmounted by the friendly assistance of Mr Watt, whose exertions at this critical period were eminently serviceable, and are acknowledged in a dedication prefixed to the first part of the *Considerations*. Mr William Clayfield and Mr Read also contributed their assistance in the invention of different parts of the pneumatic apparatus. At the opening of the institution in 1798, the sums subscribed were found to be very inadequate to the purposes for which it was designed; but every deficiency in this respect was amply supplied by the liberality of Mr Thomas Wedgewood, who offered Dr Beddoes L.1000 to enable him to carry the plan into immediate execution. All that was now wanted was to procure a superintendent; and he had the good fortune to engage in that capacity a young man, who had already given proofs of extraordinary talents, and to whose penetrating genius chemistry has since been so deeply indebted. There needs no other indication to suggest the name of Davy,—a name that will descend to distant ages, as associated with so many important discoveries in philosophical science. The history of the pneumatic institution, indeed, derives considerable splendour from many of these discoveries, which were perfected in its laboratory, and which were first announced to the world through the medium of the publications above mentioned; and in the work entitled *Researches, Chemical and Philosophical; chiefly concerning Nitrous Oxide, or De-phlogisticated Nitrous Air, and its Respiration*. By Humphrey Davy, Superintendent of the Medical Pneumatic Institution. London, 1800. The discovery of the chemical properties of this gas, and of its astonishing effects on the system when respired, were among the first, and must ever be esteemed the most brilliant, of the results of this institution; it raised the most sanguine anticipations in the mind of Dr Beddoes, and called forth all his eloquence in the description of what it already had and might be expected to accomplish. These, like the other splendid visions, in which his ardent imagination was but too prone to indulge, have never been realized; and have even created, by their signal failure, an unfortunate prejudice against future attempts to improve the art of medicine by novel methods of treatment founded on chemical or philosophical principles. The original objects of the institution being found

VOL. II. PART I.

unattainable, were successively abandoned, and it assumed, by insensible gradations, the form of the more common establishments for the relief of the sick; and the prevention rather than the cure of diseases became the principal aim of its conductors. In 1807, it was finally relinquished by Dr Beddoes to the care of Mr King and Dr Stock.

A great variety of medical topics in the meantime engaged the active mind of Dr Beddoes, and gave employment to his pen. In the strictly practical branch of the art we may enumerate, in addition to the works above mentioned,—in 1793, *A Letter to Dr Darwin on a new mode of treating Pulmonary Consumption*.—In 1795, an edition of *Brown's Elements of Medicine*, with a preface and notes.—Translation from the Spanish of *Gimbernat's new method of operating in Femoral Hernia*.—In 1799, *Popular Essay on Consumption*.—In 1801, *Essay on the medical and domestic Management of the Consumptive, on Digitalis, and on Scrofula*.—In 1807, *Researches, Anatomical and Practical, concerning Fever as connected with Inflammation*. In this latter work he successfully combats the theory of Dr Clutterbuck and of Ploucquet, in which fever is supposed to consist essentially in topical inflammation or its membranes.

The object which Dr Beddoes had ever most at heart was, to excite a lively and general attention to the means of preserving health, and of repelling the first inroads of disease, by the diffusion of medical knowledge throughout all ranks of the community, as far as they were capable of acquiring it. His attention was uniformly directed to this favourite object, and he suffered no opportunity to escape of enforcing those maxims which tend to prevent the necessity of the interference of his art. His works on popular subjects, on the improvements of medical education, and the exercise of the profession; and the popular lectures which he promoted, and in which he himself took an active part, all tended to this object. To this head may be referred the following publications: In 1794, *A Guide for Self-preservation and Parental Affection*. *A Proposal for the Improvement of Medicine*.—In 1797, *A Lecture Introductory to a Popular Course of Anatomy*.—In 1798, *A Suggestion towards an Essential Improvement in the Bristol Infirmary*. But more especially his *Hygeiu, or Essays, Moral and Medical, on the causes affecting the Personal State of the Middling and Affluent Classes*, in 3 vols. 1801-2; in which he embraces a great variety of topics, and describes, with a glowing pencil, and occasionally with extraordinary eloquence, the sufferings of patients under different diseases. In 1806, there appeared *The Manual of Health, or the Invalid conducted safely through the Seasons*.—In 1808, *A Letter to Sir Joseph Banks on the prevailing Discontents, Abuses, and Imperfections in Medicine*; and, in the same year, *Good Advice for the Husbandman in Harvest, and for all those who labour hard in hot Births; as also for others who will take it in Warm Weather*; which was the last production he ever wrote, his death happening soon after, of dropsy and enlargement of the pericardium, in December 1808.

Dr Beddoes has been very justly characterized as a

D D

Beddoes.

Beddoes
Bedfordshire.

pioneer in the road to discovery. He was full of ardour and enterprise in the pursuit of knowledge, and was easily captivated by every new project that seemed to lead towards any practical improvement. He was more active, however, in exciting the labours of others, than in labouring himself in the field of experiment. He had the imagination of a poet, and could paint in the most vivid colours the sufferings entailed by disease, and enforce with the most powerful eloquence whatever he wished to impress on the minds of his readers. He has been accused of versatility of opinion; but, if he was, perhaps, hasty in publishing the first conceptions which he formed, he has atoned for this fault by the remarkable candour with which he retracted them the moment his confidence in them was shaken. He took a decided line in politics, as appears from the following political publications of his, which appeared in 1795, 1796, and 1797: viz. *A Word in Defence of the Bill of Rights against Gagging-Bills.—Where would be the Harm of a Speedy Peace?—An Essay on the Public Merits of Mr Pitt.—A Letter to Mr Pitt on the Scarcity.—Alternatives Compared, or What shall the Rich do to be Safe?*

See Dr Stock's *Memoirs of the Life of Dr Beddoes*, London, 1811.

(w.)

BEDFORDSHIRE. The article, in the original work, on this county, is almost exclusively confined to its ancient history, and its antiquities, and in the short notices which it gives on other points, it is by no means accurate. In this article, therefore, we shall attend to what is omitted or incorrect in the former.

Boundaries
and Extent.

This county possesses no natural limits, except the Ouse for a short space on the east and west sides, and a rivulet on the south-west border. It is situate between the parallels of 51.47 and 52.17 north latitude, and between 0.17 and 0.46 west longitude from Greenwich. According to the report to the Board of Agriculture, it contains 307,200 acres; according to the returns to Parliament of the poor-rates, drawn up under the inspection of Mr Rose, 275,200; and according to Dr Beeke, in his *Observations on the Income Tax*, 293,059. Nearly the whole of this county is situate on the eastern side of the grand ridge of the island, and consequently nearly all its waters drain off in that direction.

Face of the
Country.

The face of the country is, in general, varied with small hills and valleys, and affords few extensive level tracts. The highest range of hills are the Chiltern, which cross a part, and skirt the remainder of the southern extremity of this county. This ridge frequently projects abruptly into the valleys in a striking manner. Under it is a large tract of hard, sterile land, which gives this part a dreary and uncomfortable appearance. The next most considerable range, in point of height, is of clay, crossing the county near its northern end. The next range is of sand, and enters the county on its western side, near Apsley-Guise, and passes on in a north-eastern direction. The other ranges are for the most part of alluvial clay.

Strata.

Four-fifths of the surface of this county are covered with alluvial soils, which consist principally of yellow and dark coloured clays. Fuller, speaking in general terms of its soil, gives a pretty just description of it, by saying, that it is a deep clay with

a belt or girdle of sand about, or rather athwart the body of it, from Woburn to Potton. This soil prevails in the north-west parts. From the south-eastern corner to the middle of the county, light loam, sand, gravel, and chalk predominate. The western part is, for the most part, flat and sandy. In the south-west, about Woburn, are large tracts of deep barren soil. Upon the gravel, in the bottoms of the vales in the sand district, there is a considerable quantity of peat, which contains a large quantity of sulphuric acid.

The uppermost stratum in Bedfordshire is a thick body of chalk, with numerous layers of flints. This advances no farther northward or north-west than Luton and Dunstable. Hard chalk, without flints, succeeds. Near the bottom of this is a very durable freestone. The upper and lower chalk strata are together about 400 feet thick. Chalk-marl succeeds the chalk. To the northward of Hockliff there are thick masses of alluvial clay. The ferruginous sand stratum of Woburn crosses the county, as has been already mentioned, from Woburn to Potton. It is about 170 or 180 feet thick. Near the bottom of it are beds of fuller's earth. This substance is found from five to seven or eight feet thick, between beds of sand or sandstone, over several hundred acres on the north-west of Woburn, both in Bedfordshire and Buckinghamshire. Formerly, the most extensive workings were in Apsley-Guise parish, in the former county; but, at present, the only pit that is used is in Buckinghamshire. The site of Bedford is formed of a stratum of clunch clay; it is the thickest of the Bedfordshire strata, and extends for several miles to the south side of the county town. In some parts of this stratum, there are beds of argillaceous schist, so impregnated with a bituminous substance as to burn like bad coal. In the immediate site of the town of Bedford are several strata of grey compact limestone, which are probably the lowest strata in the county. The strata of Bedfordshire have a pretty regular dip towards the south-east, at the rates of 1 in 50 to 1 in 80.

Amongst the most rare of the indigenous plants Rare of this county may be enumerated *Lythrum hyssopifolium*, grass-poly, or small hedge-hyssop, which grows plentifully in the fields between Oakley and Clapham; *Campanula latifolia*, giant throat-wort, and *Eriophoron polystachion*, cotton grass, near Dunstable; *Geranium phæum*, spotted cranes-bill, near Eversholt; *Hyoseris minema*, small swines' succory, near Aspley and Amphill; and *Ornithogalum pyrenaicum*, spiked star of Bethelam, near Eaton-Locon. Dr Abbot, who has published a very ample *Flora* of the indigenous plants of this county, found the *Euphorbia cyparissias*, considered as a doubtful native plant, growing wild in Barton-lect woods.

According to meteorological observations made at Climate. Leighton-Buzzard, the monthly mean for four years, ending the 1st of January 1804, of the barometer, was 29.520; of the thermometer, with a northern aspect, observed at eight o'clock in the morning, without the house, 47.2, within the house, 49.6; of rain, 1.93 inches; and of evaporation, 1.05. The most prevalent wind, during that period, was south-west by west.

Bedfordshire.
Rivers.

The principal rivers in this county are the Ouse, the Ivel, and the Ouzel. The circuitous course of the first has been much exaggerated. As it is described on Jeffries's map, which was made by a trigonometrical survey, its course does not appear to be more than 45 miles. It enters this county from Buckinghamshire, in the parish of Turvey, and, taking a winding course through fertile meadows, passes the town of Bedford, from which it becomes navigable, and makes its exit into Huntingdonshire. Its stream is remarkably slow, except in time of floods, when it is liable to great inundations. Its average depth is about ten feet. The fish of the Ouse are pike, perch, bream, chub, bleak, cray-fish, eels, dace, roach, and gudgeon. The eels are of a very large size, in great abundance, and very fine. The Ivel enters Bedfordshire near Stodfield. At Biggleswade it becomes navigable, and at Tomsford falls into the Ouse. It is particularly famous for gudgeon. The Ouzel separates this county from Buckinghamshire, in its course to Leighton-Buzzard. The Lea rises in Bedfordshire, and runs through the whole extent of Luton parish. The Grand Junction Canal touches the borders of this county for about three miles, near Leighton-Buzzard.

Landed Property.

There are several very large estates in Bedfordshire, the principal of which belong to the Duke of Bedford, the Marquis of Bute, the Earl of Upper Ossory, Lord St John, Earl Spencer, and Mr Whitbread. The principal agricultural products are corn and butter. Much of the former is sent down the Ouse to Lynn, and the latter goes principally to London by land-carriage. This county has been long noted for its abundant produce of fine wheat and barley. The vale of Bedford is one of the most extensive corn districts. The rich dairy ground principally extends in a line, from the middle of the county to the south-east corner. In some parts of Bedfordshire, especially in the parish of Sandy, garden vegetables are raised in considerable quantities for the supply of the neighbouring towns. The agriculture of this county, it is well known, was extremely indebted to the judicious and liberal patronage and example of the late Duke of Bedford. His favourite pursuits were experimental agriculture and the breeding of cattle. For these purposes, he kept several farms in his own hand. The principal farm-yard is in Woburn park. The buildings of every kind are upon the most extensive scale, and abound in every convenience. One of the most remarkable is the room constructed for showing the sheep at the annual shearing. On the farm at Woburn is a mill for malting, thrashing, winnowing, &c. The cultivation of woad, mentioned by former writers as carried on to a considerable extent in Bedfordshire, has long been laid aside. On what are called the "woodland soils," and on the colder parts of the alluvial clay, particularly the steep sides of the hills, in the northern and middle parts of the county, there are between 6000 and 7000 acres of very old wood. There are also about 500 acres on the sand, where also large plantations of fir have been made. A considerable part of the timber that is felled is sent to the sea coast by the Ouse.

Produce.

Woburn.

Woods.

Manufactures.

The principal manufactures are the plaiting of

Bedfordshire.

straw, and making it into bonnets, &c. and thread-lace. The straw manufacture prevails, and latterly has much increased, in the neighbourhood of Dunstable and Toddington, and on the borders of Hertfordshire. The employment is deemed more healthy than that of lace-making, as the straw may be plaited by persons standing or walking. The earnings, even of those who make the coarse plait, are higher than those of the lace-makers; and the profit of making the fine plait is very considerable. Thread-lace, formerly known by the name of bone-lace, was for a long time the staple manufacture of this county; but latterly it has given way to the manufacture of straw; and has farther declined in consequence of the general introduction of cotton-lace. It is now made only in a very few villages in the neighbourhood of Buckinghamshire, and in the town of Bedford. It is not so fine in its texture as the lace made in some parts of Buckinghamshire. The average day's-work of an adult, when the manufacture flourished, was rather more than a shilling a-day; the children earning from threepence to sixpence. The posture in which the manufacturers sit, the sedentary nature of the employment, and the habit of working together in crowded rooms, ill ventilated, give the manufacturers a weak and sickly appearance. In the neighbourhood of Dunstable, there is a whiting manufactory, which employs a few people.

In the year 1377, the number of persons in this county who were charged to a poll-tax, from which the clergy, children, and paupers were exempted, amounted to 20,239. This tax was levied not long after a fatal pestilence. In the year 1700, the total population was estimated at 48,500; in 1750, 53,900. By the returns to Parliament, in 1801, the number of inhabited houses was 11,888; of uninhabited 185; the number of families was 13,980; the number of persons chiefly employed in agriculture was 18,766; the persons chiefly employed in manufactures, trade, and handicraft, 13,816; and persons to whom no occupation was assigned, and children, was 28,789; the total number of resident inhabitants was 63,393; of whom 30,523 were males, and 32,870 females. The population, in 1811, had increased to 70,213; of whom 33,171 were males, and 37,042 females; the number of inhabited houses was 13,286; of families 14,927; of houses building 139; of houses uninhabited 219;—the number of families employed in agriculture was 9431; and the annual value of the land at rack-rent was nearly L.280,000. The number of families chiefly employed in trade, manufactures, &c. was 4155; and the amount of annual profits was rather more than L.94,000. The number of people to a square mile was 171; the annual proportions of baptisms was 1 to 32 persons; of burials, 1 to 56; and of marriages, 1 to 126.

In the year 1776, the amount of the poor-rates raised in this county was L.18,193; in the year 1784, L.22,638; and in the year 1803, L.47,484. This was at the rate of 3s. 9½d. in the pound, on a rental of L.248,600, or 14s. 9½d. a head, on the whole population. The total expenditure for the poor, in 1808, was L.38,070; nearly L.10,000 being ex-

Population.

Poor-rates.

Bedfordshire
||
Bee.

pendent in law-suits, county-rates, &c.; L.37,944 was distributed to 7276 persons, or 1 in every 8- $\frac{1}{4}$ th of the whole population, the average allowance being 2s. a week. Of these paupers, 674 were wholly maintained in work-houses, at the average expence of L.12, 10s. 5 $\frac{1}{2}$ d. each annually, or 4s. 9 $\frac{1}{2}$ d. per week. There were at that time 2370 persons associated in 75 Friendly Societies: eight parishes in the county had schools of industry, in which 196 children were taught to work. Only an incomplete return has as yet been made to Parliament of the poor-rates, or other rate or rates raised in Bedfordshire, in the year ending 25th March 1815; six parishes out of the 140 having made no return; but it appears, from the return actually made, that 134 parishes paid, at that time, L.69,464, 6s. 3 $\frac{1}{2}$ d.

Gothic Architecture.

Remains of the earliest style of Gothic architecture are to be seen in this county, in the nave of Elstow church, in the west part of Folmeisham church, and in the west end of Dunstable church. Of the succeeding style of Gothic architecture, which prevailed during the fourteenth century, few examples are to be met with in Bedfordshire. Wymington church, however, though small, is an elegant specimen of it, and appears never to have been altered. Several of the Bedfordshire churches are in the latter style of Gothic architecture, which prevailed during the fifteenth, and the beginning of the sixteenth centuries. The churches of Northill, Wymington, Mayton, Eaton-Socon, Odill, Biggleswove, and St Paul's at Bedford, are in this style.

Historical Notices.

In the original work, there are notices of the history of this county till the time of Alfred. Nothing important occurred in it for several centuries afterwards. During the civil wars between the houses of York and Lancaster, it presents no remarkable events, probably in consequence of the destruction of its castles by King John, in his march northward. But Bedfordshire was one of the first counties that associated against Charles I.; and Lord Clarendon observes, that this was one of the counties in which the King had not any visible party, nor one fixed quarter.

Town of Bedford.

To the notice of the town of Bedford, in the original work, some particulars may be added. It is 50 miles north-west by north from London; the latitude of St Paul's church, according to the government trigonometrical survey, is 52, 8, 8, 8, north; and its longitude 0, 27, 43, 3, west of Greenwich Observatory, or 1', 50", 9, in time. The right of election is vested in the burgesses, freemen, and inhabiting householders not receiving alms; their number is about 1400. Besides its parish-churches, its public buildings, are a county-infirmery, a county-jail, and bridewell, a town-jail, and a county-hall. It is situate rather to the north of the centre of the

county, and in the midst of a very rich tract of land, called the Vale of Bedford. The Ouse is navigable from the Eastern Sea to this town. By its situation, on this river, the inhabitants carry on a considerable trade in forwarding the corn of the adjacent fertile country to Lynn; and in importing from thence coals, timber, wine, and groceries. The inundations of the Ouse have been more frequent and destructive latterly than they used to be, in consequence, it is supposed, of the many newly inclosed parishes, which drain into the river. There is sometimes a stagnation of water in the meadows of the Ouse, near Bedford, to the depth of 12 or 14 feet.

Thread-lace is the principal manufacture of the place. According to the Parliamentary returns of 1801, of 3948 inhabitants, which it then contained, there were 2236 females. This great disproportion between the sexes has been justly ascribed to the will of Sir William Harper, who, in the year 1561, bequeathed 13 $\frac{1}{4}$ acres of land in the parish of St Andrew, Holborn, to the corporation of Bedford, for the support of a grammar-school, and the apportioning young women of the town upon marriage. The rent of this estate being now between L. 4000 and L. 5000, it may well be supposed that young women from the vicinity of Bedford are drawn into the town in the hope of getting apportioned and married. In 1811, the population of the town consisted of 2057 males, and 2548 females; the inhabited houses were 940, and the families inhabiting them 1099.

The principal market at Bedford, held on Saturday, on the north side of the river, is a considerable mart for corn. The Monday market, on the south side of the river, is chiefly for pigs. There are six annual fairs, besides a fair held in the vicinity at St Leonard's Farm.

It is generally supposed that Bedford is the Bedford of the *Saxon Chronicle*, where the battle was fought between Cuthwulf and the Britons in 572; it is said to have been the burial place of Offa, king of the Mercians. According to *Doomsday-book*, it was taxed as half a hundred, both for soldiers and shipping. Before the Conquest, there was a collegiate church here, dedicated to St Paul. The celebrated John Bunyan was porter of an independent meeting-house in Mill Lane, from 1671 till his death in 1688. His memory is much revered by the congregation, and the chair in which he used to sit is preserved as a relic in the vestry. The Moravians have had an establishment at Bedford ever since the year 1745.

See Bachelor's *Agricultural Report of Bedfordshire*; —*Beauties of England and Wales*, Vol. I.; —Lyson's *Magna Britannia*, Vol. I.; —Smith's *Map of the Strata of England, with a Memoir*. (c.)

B E E.

Progress of Knowledge regarding this Insect.

THE Bee, from its singular instincts, its active industry, and the useful products resulting from its labours, has, from the remotest times, attracted the attention, not only of naturalists, but of mankind in

general. No nation upon earth has had so many historians as this remarkable tribe of insects. The patience and sagacity of the naturalist have had an ample field for exercise in the study of their struc-

Bee. ture, physiology, and domestic economy. Their preservation and increase have been objects of assiduous care to the agriculturist; and their reputed perfection of policy and government, have long been the theme of admiration, and have afforded copious materials for argument and allusion to the poet and the moralist in every age. It is a subject that has been celebrated and adorned by the muse of Virgil, as well as illustrated by the philosophic genius of Aristotle. Cicero and Pliny report that Aristomachus devoted himself during sixty years to the study of these insects; and Philiscus is said to have retired into a desert wood, that he might pursue his observations on them without interruption. A prodigious number of authors have written express treatises on bees; periodical works have been published relating exclusively to their management and economy; and learned societies have been established for the sole purpose of conducting researches on this subject. The most celebrated association of this kind is the *Société des Abeilles*, founded about fifty years ago in Little Bautzen, a village in Upper Lusatia, under the auspices of the Elector of Saxony. Its labours, as we shall presently find, have enriched the science with a number of valuable discoveries.

In so complicated a branch of natural history, the application of the difficult art of observing correctly, and of the cautious processes of induction, cannot be effected without laborious and long continued efforts. But, on the subject of bees, the inquirer after truth had, besides, many obstacles to encounter, from the very general diffusion of errors, which had been transmitted without due examination from one author to another. The history of the opinions of successive writers, will sufficiently prove how gradual and how slow has been the advancement of real knowledge in what concerns these insects, and will teach us to estimate the value of that which we at length possess, as being the result of the labour of ages, and as being extorted from nature by indefatigable and persevering exertions. So great an accumulation of curious and interesting facts, indeed, has accrued to us from the researches of Swammerdam, Maraldi, Reaumur, Schirach, and Huber, as to constitute almost a new science. Many of these have been discovered subsequent to the time of the compilation of the article *BEE* in the *Encyclopædia*. It will therefore be proper, in this place, to give a connected and systematic account of the natural history of this remarkable insect. For the details of the external characters and distinctions of species, we shall refer to what has been already stated in the above article, and in that of *ENTOMOLOGY*. The principal features of their internal conformation will be described when treating of the particular functions to which they are more immediately subservient; and our descriptions will apply, more especially, to the common and best known species, the *Apis mellifica*, which is the one particularly prized on account of the rich products it affords.

Plan of this Article.

The economy of bees comprehends so wide a field of inquiry, the different parts of which are so connected and dependant upon one another, that it is impossible to treat of them distinctly, without

Bee. supposing the reader to possess some general acquaintance with the history of these insects. We shall, therefore, premise a brief account of the different sorts of bees inhabiting the hive, and of the respective offices of each. We shall then proceed to consider their comparative physiology; under which head we shall state the leading particulars relating to their nutrition, secretion, respiration, progressive motion, external senses and instincts. We shall next follow them in their different labours, from the period when the swarm has settled in a new habitation; we shall detail the complex structure of their hives,—their curious processes of architecture,—the pains they bestow on rearing their progeny and in sending forth new swarms; and this will lead us to the subject of the fecundation of the queens, and the massacre of the drones. After having thus given an account of their usual condition, we shall, in the last place, describe the result of several experiments and observations, which have been made when they were placed in unusual circumstances; experiments which have exhibited many interesting features of their character, and have thrown considerable light on the whole of their history, as well as suggested various practical and economic applications in the management of these insects.

The leading feature in their history, and one which distinguishes them from almost all insects, is their singular distribution into three different kinds, constituting, to all appearance, so many different modifications of sex. The drone, which is characterized by a thicker body, a round head, a more flattened shape, and more obtusely terminated abdomen, within which are contained the male organs of generation, has been admitted as the male of the species. It is distinguished, also, by the absence of a sting, and by the humming noise that accompanies its flight. The queen-bee, which is larger than any of the others, has the abdomen of greater length, and is provided with a sting, and with two ovaria of considerable size, is unequivocally recognised as the female. The working-bees compose the third class, and are distinguished by the smallness of their size, their lengthened proboscis, the peculiar structure of their legs and thighs, which are adapted to the collection of certain materials collected from vegetables, and by the apparent absence of every trace of generative organs,—we say apparent absence, because, as will be hereafter stated, rudiments of ovaria have been very lately discovered to exist, which, however, are not perceptible without a very minute and careful dissection. Till within a few years, the working-bees were regarded as animals deprived of sex, and were accordingly termed *neuters* or *mules*. It is these which perform all the laborious offices for the community,—which construct the interior of their habitation,—which explore the country in search of nourishment and other materials,—which collect and bring them to the hive, and apply them to different purposes; it is they who assiduously attend upon the queen, and supply all her wants,—who defend the hive from the attacks of depredators,—and who carry on hostilities against the various enemies of the tribe. The life of the females is chiefly engrossed

Functions of the Males, Females, and Neuters.

Bee.

with the duties of laying eggs, and conducting the colonies, which, at certain periods, emigrate from the parent state. The drones, producing neither wax nor honey, and depending on the rest for their subsistence, are idle spectators of these labours. They appear to be formed only for the momentary, but important duty of impregnation; since they perish when this purpose is accomplished. There is commonly only one perfect queen existing at a time within each hive; and she appears to be treated by all the other bees with every mark of affection and of deference. The number of labourers is very different in different hives; sometimes there are only a few thousands, at other times, from twenty to forty, or even fifty thousand. The drones, even in the spring, seldom compose more than one-thirtieth, or one-fortieth of the whole; and, at other seasons, there are none to be found in the hive. In order to form some estimate of the number of bees which can occupy a certain space, Mr Hunter counted what number of drowned bees could be contained in an alehouse pint, and found it to be 2160; so that if a swarm were to fill two quarts, their numbers would be nearly 9000. Reaumur, with the same view of ascertaining their numbers, employed the more accurate method of weighing them; he found that a collection of them, weighing one ounce, consisted of 336 bees; and, therefore, that 16 ounces, or one pound, would consist of 5376 bees.

Real Sex of
the Work-
ing-Bees.

Notwithstanding these differences in conformation, instincts, and offices between the queen-bee and the workers, it is now established, upon the most incontrovertible evidence, that they both originally proceed from the same kind of larva, and that the queen-bee lays only two kinds of eggs, the one destined to produce the drone, the others capable of being converted, according to circumstances, either into a worker or a queen. It has been proved that the former, although exhibiting no appearance of sexual organs on a superficial examination, are in reality females, and have the rudiments of these organs, which, from their not being developed, are incapable of exercising their proper functions. The principal facts from which these conclusions were derived have already been briefly stated in the article BEE in the *Encyclopædia*, but the evidence was at that time scarcely sufficient to carry complete conviction to the mind. It may be remarked, that the idea of the working-bees being radically females had been given out long ago by Dr Warder, in his *Monarchy of Bees*, in which he terms them "True Amazones;" but no attention had been paid to his opinion. The real merit of this great discovery, which affords the key to a multitude of hitherto inexplicable facts, unquestionably belongs to Mr Schirach, vicar of Little Bautzen, the Secretary of the Lusatian Society, to which we formerly adverted. When first announced to the world, it was received with suspicion by the greater number of naturalists, and with complete incredulity by others. It was, indeed, at variance with the whole tenor of the observations of Swammerdam, Maraldi, and Reaumur. Wilhelm, the brother-in-law of Schirach, though an eye witness to the experiments from which he had deduced this theory, for a long time refused to admit the doc-

Bee.

trine; but became at length one of its most strenuous supporters. It is noticed in a vein of sarcastic ridicule by Mr John Hunter, in his otherwise excellent paper on bees in the *Philosophical Transactions*. Needham wrote a memoir for the Imperial Academy of Brussels, in 1777, for the express purpose of refuting it; and he then inveighs in strong language against those naturalists who had deigned to give it the least countenance. Mr Key, in the *Bath Society Papers*, declares that he made experiments on this subject for eight years, without obtaining a single result in conformity to Schirach's views. Bonnet, after exercising a laudable scepticism, and making a diligent inquiry, in which he displays a genuine spirit of philosophy, yielded a reluctant assent. But the truth of the doctrine has since been placed beyond the reach of controversy by multiplied series of observations and experiments in different parts of Europe; and more especially by the recent investigations of Mr Huber of Geneva. We shall not at present enter into the detail of proofs, because their force will be better appreciated when other particulars belonging to the history of the bee have been explained.

In considering the physiology of the bee, the first Nutrition. function that claims our notice is that of Nutrition. The food of bees is principally of two kinds; Nature of namely, the fluid secretions of vegetables contained in the nectarea of the flowers, and the dust of the ^{the Food of Bees.} antheræ, which has been termed by botanists the pollen, but which, when collected by the bees, has received a variety of appellations, such as farina, bee-bread, raw wax (*cire-brute*), &c. Occasionally, however, we find bees feeding upon other saccharine substances besides honey, such as honey-dew, treacle, syrup, &c.

The organs by which they collect food are extremely complex, for they comprise instruments adapted to the reception of liquid aliment, as well as those fitted for the division of solid materials. Reaumur has given the most elaborate description of these organs, in which he has corrected some errors that Swammerdam had fallen into. For the purpose of taking up fluids they are provided, in common with all hymenopterous insects, with a long and flexible proboscis or trunk, which may be considered as a lengthened tongue, though, strictly speaking, it is formed by a prolongation of the under lip. It is not tubular, as Swammerdam had supposed, but solid throughout, and the minute depression at its extremity is not the aperture of any canal through which liquids can be absorbed. Cuvier, in his *Leçons d'Anatomie Comparée*, has not marked this distinguishing feature in the proboscis of the bee, but speaks of it in common with the tubular trunks of the other hymenoptera, and describes its aperture as being situated in the lower part. But Reaumur has very satisfactorily shown that the trunk of the bee performs strictly the office of a tongue, and not that of a tube for suction, for when it takes up honey or other fluid aliment, the under or the upper surfaces are more immediately applied to it, and rolled from side to side, and the bee thus licks up what adheres to it, while the extremity of the trunk is frequently not applied at all to the substance ta-

Bee. ken up. The trunk is supported on a pedicle which admits of being bent back, or propelled forwards, and thus can retract or stretch out the trunk to a considerable extent. Protection is given to it by a double sheath; the external consisting of two scales furnished by the expansion of one of the portions of the labial palpi, and the internal, formed by the prolongation of the two external portions of the jaw. The whole member thus consists of five principal parts, on which account Fabricius termed it *lingua quinquefida*.

Mandibles. For the purpose of mechanically dividing solid materials, the mouth is furnished with two strong mandibles and four palpi; they are but little employed in eating, but are of great use in enabling the insect to seize and break down hard substances for other purposes. In the working-bee all these parts are of larger dimensions than in the other kinds. The teeth are two in number, and have the form of concave scales with sharp edges; they are fixed to the ends of the jaws, and play horizontally as in other insects. Reaumur describes and delineates a large aperture above the root of the proboscis, which is so surrounded with fleshy parts as not to be readily seen, unless the proboscis be extended and bent downwards. This he considers as the mouth or orifice of the gullet; on the upper side of which, and of course opposite to the root of the proboscis, a small fleshy and pointed organ is seen, which he regards as the tongue, assisting in the deglutition of the food. Through this orifice, it is presumed, all the aliment, whether liquid or solid, passes; the former being conveyed to it by the trunk, which, by its contractile power, presses forward the fluids it has collected between itself and the inner sheath, and the latter being received directly after its comminution by the teeth, behind which it is situated. Latreille, however, whose authority is great on a point of this nature, thinks that Reaumur has deceived himself with regard to such an aperture, and disbelieves its existence. He conceives that the food simply passes on by the sides of the tongue, finding its way from thence into the œsophagus, and so on to the stomach.

Stomachs. The bee has two stomachs: The first is a large transparent membranous bag, pointed in front, and swelling out into two pouches behind. It performs an office, in some respects, analogous to that of the crop in birds; for it receives, and retains for a time, the fluid of the nectarea, which does not appear to differ, in any respect, from honey. Mr Hunter observes, that, whatever time the contents of this reservoir may be retained, he never found them altered, so as to give the idea of digestion having taken place. The coats of this reservoir are muscular, by which means it is capable of throwing up the honey into the mouth, so that it is regurgitated into the honey cells, or imparted to other bees. None of it ever passes out from the extremity of the trunk, as Swammerdam had believed. For the purpose of digestion, a second stomach is provided, which takes its origin from the middle of the two posterior lobes of the former, and is of a lengthened cylindrical shape. Its communication with the intestine is not direct, but takes place by a projecting or inverted

Bee. pylorus, thickest at its most projecting part, with a very small opening in the centre, of a peculiar construction. This inward projecting part is easily seen through the coats of the reservoir, especially if full of honey. A similar kind of structure takes place at the communication of the first with the second stomachs, and, having the properties of a valve, must effectually prevent all regurgitation from the latter into the former.

The pollen of flowers, which is the other principal article of food, was shown by Swammerdam to consist of an infinite number of small particles, generally of a globular shape, each of which is found to be a small capsule, enclosing the still finer dust or fecundating principle, destined to be shed on the pistils for the purpose of germination. Geoffroy has given a memoir, published in the *Collection Académique des Sciences*, containing a minute description of the shapes of these capsules, taken from different flowers. The working-bees, by means of the pencil of hair which grows on the tarsi, first collect a certain quantity of pollen, which they knead together into a ball, and place it in the concave space which is situated at the middle joint of the hinder feet, and has been termed the basket. The surrounding rows of hairs keep the ball from falling off. In order to gather larger quantities at once, the bees are sometimes observed to roll their bodies on the flower, and then brushing off the pollen which adheres to them with their feet, form it into two masses, which they dispose of as before mentioned; and it is said, that, in moist weather, when the particles of pollen cannot be readily made to cohere together, they return to their hive, dusted all over with pollen, which they then brush off with their feet. They are often obliged to tear open the capsules which contain the pollen, in order to procure a supply of this substance, when it has not yet been shed by the flowers.

Pollen is yielded by flowers during the spring in such abundance, that the bees of a single hive will often bring back one pound, or even more, in a day. Some agriculturists have accordingly imagined, that the vegetation of some plants might be endangered from this great consumption of the fecundating principle by insects in general; for other insects, besides bees, seek it with great avidity. But this fear has been proved to be totally without foundation, and the practice of destroying bees in order to prevent this imaginary danger, is therefore as useless as it is barbarous. It would appear, indeed, that so far from obstructing the fecundation of plants, the labours of the bee have often tended materially to promote it, by the agitation which they gave to the flower, and by transporting the pollen from one flower to another. In this manner may we account for the number of hybrid flowers that are met with near the haunts of bees.

It has been shown very clearly by Huber, in a paper in the *Journal de Physique*, that pollen is peculiarly the food of the young bees, and is collected by the working-bees with this intention. Reaumur, however, asserts that he has seen adult bees devour pollen. Swammerdam, who conceived the trunk to be tubular, rejected the idea that pollen could ever be the food of bees, as the globules of which it con-

Bee: sists are incapable of entering an orifice so minute as that which appears at the extremity of the trunk, and which, as he was unacquainted with the real mouth, he thought was the only passage to the stomach. Latreille, who does not admit the existence of the large mouth described by Reaumur, states that the mandibles lay hold of the pollen, and carry it to the base of the trunk, from whence it finds its way into the cesophagus, by the sides of that organ.

On the nature of HONEY-DEW, and the consumption of it by bees, a sufficient account has already been given in the *Encyclopædia*, under that article.

An abundant supply of water is essential to the healthy condition of bees. They consume a large quantity, and often stop to drink at the edge of stagnant pools, and seem even to prefer putrid and urinous waters to purer streams, as if their saline and pungent qualities were grateful to them.

**Producti
of Wax.**

It has been long the opinion that wax was but a slight modification of pollen, which required for this conversion merely the application of a certain pressure, and a kind of kneading by the feet of the bees. Many naturalists, such as Bernard de Jussieu, had persuaded themselves that the dust of the stamina of flowers contained wax ready formed, as one of its ingredients; and quoted the following experiment in proof of this opinion: If the minute grains of pollen be put into water, they gradually swell, till they at length burst, at which moment a small jet of an oily liquor will be perceived, which floats on the water without mixing with it. But Reaumur had attempted in vain to extract any thing like wax from dust of the antheræ; and, indeed, an attention to the chemical properties of these two substances would have sufficiently pointed out their essential differences. From the upper surface of the leaves of many kinds of trees, a substance has, indeed, been obtained, which possesses all the qualities of bees' wax; but nothing like it can be extracted from pollen. Reaumur was persuaded that the pollen was elaborated in the second stomach of the bee; and thrown up into the mouth in the form of a white foam, which, by exposure to the air, hardened, and became wax; and that the bee took advantage of its soft state to apply it in the building of the combs. So circumstantial an account, given to us by a scrupulous observer of facts, appeared to be perfectly satisfactory, and was acquiesced in by naturalists in general. But it has since been completely proved by the researches of Duchet, of Hunter, and of Huber, but principally by the latter, that wax is a secretion from the abdomen of the bee; and that it depends not at all on the pollen which the insect may consume, but on the quantity of honey or other saccharine substance which it receives into the stomach. The first step in this discovery was made by one of the members of the *Lusatian Society*, whose name has not been preserved. It was mentioned in a letter of Mr Wilhelmi to Bonnet in August 1768, in which he says that wax, instead of being rejected by the mouth, exudes from the rings which inclose the posterior part of the body. Of this we may satisfy ourselves by drawing out the bee from the cell in which it is working with wax, by means of the point of a

fine needle; and we may perceive, in proportion as the body is elongated, that the wax will make its appearance under the rings, in the form of small scales. Mr Duchet, in his *Culture des Abeilles*, gives a full statement of the principal circumstances attending the production of wax, which he very justly ascribes to the conversion of honey into this substance in the body of the bee. These facts appear to have been entirely overlooked till the subject was again brought forward by Mr John Hunter, in his paper in the *Philosophical Transactions* for 1792. Wildman, however, had cursorily remarked, that portions of wax, in the form of scales, and which he conceived must have been moulded on the body of the bee, are sometimes found at the bottom of the hive. M. Huber was prosecuting his inquiries on this subject at the same period with Mr Hunter, and discovered, in 1793, the existence of regular receptacles, or pouches, from the coats of which the wax is secreted, and within which it accumulates till its edges raise the scales, and become apparent externally. These plates of wax are withdrawn by the bee itself, or some of its fellow-labourers, and is applied in a manner hereafter to be described.

Huber has shown, by a series of well conducted experiments, that, in a natural state, the quantity of wax secreted is in proportion to the consumption of honey; but that an equal, or even greater quantity, will be formed, if the bee be fed on a solution of sugar in water. Warmth and rest promote this process of secretion; for the bees, after feeding plentifully on saccharine food, hang together in a cluster, without moving, for several hours, at the end of which time, large plates of wax are found under the abdominal rings. This happened when bees were confined and restricted from any other sort of nourishment; while those that were fed on pollen and fruits alone, did not produce any wax. It appears also from his researches, that the formation of wax is the office of a particular set of bees, which may be distinguished from the rest, and particularly from those that nurse the young larvæ, by the greater size and more cylindrical shape of their abdomen. Dissection also shows that their stomachs are more capacious. Having already given the details of the experiments of Huber on this subject, in the article ENTOMOLOGY, in the *Encyclopædia*, there is no occasion to dwell on them farther. In the second volume of Huber's *Nouvelles Observations sur les Abeilles*, he describes minutely the anatomy of the pouches or receptacles for the wax, which are parts peculiar to the working-bees, being totally absent in the males and queens. It is a structure that had escaped the keen eyes of Swammerdam, and has not been noticed by any subsequent anatomist. The cavities are lined with a membrane, which presents a number of folds, forming a hexagonal net-work, not unlike the appearance in the second stomach of ruminant quadrupeds, and evidently destined to perform the office of secretion.

Among the secretions peculiar to the bee, the poison which is poured into the wounds made by the sting deserves to be noticed. But for an account of this, as well as of the organ itself, we shall refer the reader to the article BEE, Sect. 2.

Bee.
Function of
Respiration:

As it is well known that no organs for the circulation of blood are provided in insects, this function of composing no part of their economy, respiration must be effected by means totally different from those which are adopted in the higher classes of the animal kingdom. As the blood, or fluid corresponding to the blood, cannot be presented to the air in any separate organ, the air must be conducted to the blood, wherever such a fluid is met with. For this purpose, tracheæ or air-tubes, having several external openings, or spiracles, are made to ramify like arteries, and are distributed in an infinite number of branches to every part of the body. The analogy of other insects might perhaps be admitted as sufficient evidence that bees respire atmospheric air, the constant renewal of which is essentially necessary to the continuance of the vital functions. It is, however, not always safe to trust to analogical reasoning in subjects of natural history; and direct evidence is, in all cases, to be preferred when it can be obtained. We must, therefore, consider as valuable, the complete series of experiments on the respiration of bees, that have been lately given to the world by Huber, to whom we already owe so large a portion of the information we possess with regard to these insects. We might, indeed, have anticipated, with the strongest probability, many of the results to which these experiments have led; but there are others which are quite unexpected, and possess as much interest as of novelty.

The condition of a hive of bees, in which many thousand individuals, full of animation and activity, are crowded together in the very small space of one or two cubic feet, having no communication with the external air but by means of a small aperture in the lowest part, which entrance is frequently obstructed by a throng of bees, that are passing in and out during sultry weather, is of all possible conditions the one least favourable to the renewal of heated air. The most crowded theatres or hospitals are not to be compared with it in point of closeness. Direct experiment, indeed, shows that the combustion of a taper could not be carried on in so limited a space, for Mr Huber found that in a glass ball of the same dimensions as the hive, and with a similar aperture, the taper went out in a few minutes. So great was the difficulty of explaining the respiration of bees under these circumstances, that Mr Huber was led to examine into the truth of the opinion, that respiration was equally necessary to bees as to other insects. The results were unequivocal. They perish speedily in the vacuum of the air-pump. They are easily drowned by placing them so that the spiracles on the corslet are under water; but revive easily when they are dried. The action of the spiracles is, in this experiment, rendered manifest by the escape of bubbles of air from each of their orifices. When a number of bees are confined in a bottle accurately closed, they exhibit unequivocal symptoms of distress, and fall into complete asphyxia. These changes occur more rapidly when they are placed in any gas which contains no admixture of oxygen, such as carbonic acid, hydrogenous and azotic gases. When rendered torpid by cold, and respiration thereby sus-

ended, these effects do not take place. All these effects are more considerable in adult bees than in the larvæ; though they are also distinctly exhibited in the latter. Suffocation is retarded if the proportion of oxygen be greater than in atmospheric air, and it may be averted altogether by a continual renewal of oxygen. It was ascertained by the endiometer, that the same changes were produced on the air as in the respiration of other animals; namely, the subtraction of oxygen, and the addition of an equal volume of carbonic acid gas.

Yet, on examining the air of the hive itself, it was found scarcely to differ in purity from atmospheric air. It was at one time conjectured that some of the contents of the hive; such as the pollen, the honey, or the wax, might have some power of evolving oxygen, so as to afford the requisite supply of this gas. Experiments, however, proved that they had no such power. Amidst so great an uncertainty, it was thought worth while to ascertain whether bees might not exert some unknown process, by which oxygen was generated in the hive itself. If this were true, they could support life, although all communication with the external air were intercepted. A hive was selected, having glass sides so as to allow of the observer's seeing what was passing in the interior, and the entrance was completely closed. In a quarter of an hour, the bees became sensible of their situation, and showed great uneasiness; all business was suspended; an extraordinary agitation, accompanied by a remarkable noise, prevailed in every quarter. All the bees were seen beating their wings with the same rapidity as in flying. They were thus incessantly occupied during ten minutes. Their motions became then more languid, and, after being utterly exhausted, they fell in succession to the bottom of the hive, till every one of them was in a state of complete asphyxia. It is remarkable that, at this period, the temperature of the hive, which had been previously at 95° of Fahrenheit, suddenly cooled down to that of the external air. On opening the door and the top of the hive, and establishing a current of air through it, the bees were soon restored to animation.

It was proved by this experiment, that the air is renewed through the small opening which serves as a door to the hive. By suspending light substances near the entrance, the existence of different currents of air was rendered manifest. After much reflection, it occurred that the violent agitation of the wings might have some influence in procuring this renewal of air. This conjecture was confirmed by an experiment with a glass bell, to the aperture of which an apparatus was fitted, consisting of a small ventilator, which could be moved rapidly round by machinery. When the ventilator was set in motion, the air within could support the combustion of a candle for an unlimited time. Observation further showed, that some bees are actually always employed in the office of ventilating the hive; they vibrate their wings with great vigour and constancy, producing so rapid a movement of them, that they cannot be seen except in the two extremities of the arc of vibration, which is at least one of 90°. While thus imitating the actions of flying, they fasten themselves with their

Bee.

Its Necessity.

Bee.

feet to the floor of the hive, so that the whole effect of that impulse which, were they at liberty, would carry them forwards with considerable velocity, is exerted on the air, which is therefore driven backwards in a powerful current. Some bees occasionally perform these ventilating motions on the outside of the hive, near the entrance, but a still greater number are employed in this office within doors; sometimes twenty are thus occupied at once, and each bee continues its motions for a certain time, occasionally for nearly half an hour, and is then relieved by another, who takes its place. This is the occasion of that humming sound which is constantly heard from the interior of the hive when the bees are not in a state of torpidity. But it is often heard with even more than usual loudness in the depth of winter. The warmth of the sun's rays, however, always occasions an increased activity among the ventilating bees. The immediate cause of these actions is probably some impression made on their organs by the presence of vitiated air: for a bee may be made to ventilate itself, by placing near it substances which have to them an unpleasant odour, such as spirit of wine, or oil of turpentine.

Temperature of the Hive.

The connection between an active respiration and a high temperature is remarkably exemplified in bees, among which, in consequence of their collecting together in large numbers, the heat is not so easily dissipated, and admits also of being easily ascertained by the thermometer. Mr Hunter found it to vary from 73° to 84° of Fahrenheit: and Mr Huber observed it on some occasions to rise suddenly from about 92° to above 104°.

Progressive Motion.

Bees are well fitted, by their structure, for rapid flight through the air. They possess great muscular strength in proportion to their size, and their indefatigable activity in the different labours of the hive is truly astonishing. Aristotle and Pliny have pretended that, during high winds, they endeavour to steady their flight by holding a small stone with their feet, by way of ballast. This assertion has been shown, both by Swammerdam and Reamur, to be erroneous, in as far as it applied to the common bee; but there are other species, which build nests with stones and other hard materials, and which, while transporting them for this purpose, were probably mistaken for the honey-bee.

Sensitive Powers.

The physiology of the external senses must necessarily be very imperfectly understood, in a class of animals of a nature so remote from our own species. The infinite diversity of characters presented to us by the different tribes of insects, as well as of other animals, naturally suggest the idea that external objects produce, on their sentient organs, impressions widely different from what they communicate to ourselves. The notions we form of their senses must not only be liable to great inaccuracy, but must often be totally inadequate representations of the truth. A more fine organization, and more subtle perceptions, would alone suffice to extend the sphere of their ordinary senses to an inconceivable degree, as the telescope and the microscope have with us extended the powers of vision. But they possess, in all probability, other organs, appropriated to unknown kinds of impres-

sions, and which must open to them avenues to knowledge of various kinds, to which we must ever remain total strangers. Art has with us supplied many elaborate modes of bringing within our cognizance some of the properties of matter, which nature has not immediately furnished us with the means of detecting. But who will compare our thermometers, electroscopes, or hygrometers, however elaborately constructed, with those refined instruments, with which the lower classes, and particularly insects, appear to be so liberally provided? The antennæ, which are so universally met with in this class of animals, are doubtless organs of the greatest importance in conveying impressions from without. Their continual motion, the constant use which is made of them in examining objects, the total derangement in the instincts of those insects which have been deprived of them, point them out as exquisite organs of more than one sense. To impressions of touch, arising from the immediate contact of bodies, they are highly sensible; but their motions evidently show that they are affected by objects at some distance. They are no doubt alive to all the tremulous motions of the surrounding air, and probably communicate perceptions of some of its other qualities. Composed of a great number of articulations, they are exceedingly flexible in every direction, and can readily embrace the outline of any body that the bee wishes to examine, however small its diameter, and of following all its movements. It is by means of these instruments that bees are enabled to execute so many works in the interior of the hive, from which the light must be totally excluded. Aided by these, it builds its combs, pours honey into its magazines, feeds the larvæ, and ministers to all their wants, which it discovers and judges of solely by this species of touch.

The antennæ appear also to be the principal means employed for mutual communication of impressions. The different modes of contact constitute a sort of language which appears to be susceptible of a great variety of modifications, and to be capable of supplying at once every species of information for which they have occasion. It is in this way alone that they satisfy themselves of the presence of their queen, or communicate to others the alarming intelligence that she has disappeared.

The sense residing in the antennæ appears to be, Vision. on many occasions, supplementary to that of vision, which in bees, as in other insects, is less perfect than in the larger animals. During the night, therefore, they are chiefly guided in their movements by the former of these senses. This will sufficiently appear from observing by moon-light the mode in which the bees guard the entrance of the hive against the intrusion of moths which flutter in the neighbourhood. They act as vigilant sentinels, performing continual rounds near this important post, extending their antennæ to the utmost, and moving them alternately to the right and to the left. Woe to the unfortunate moth that comes within their reach. Aware of its danger, and of the defective sight of the bees, the moths adroitly avoid the slightest contact, and endeavour to insinuate themselves between the bees, so as to get unperceived in-

Bee.

Functions of the Antennæ.

Bee. to the hive, where they riot upon the honey which they find.

If bees require full day-light for the exercise of vision, it must, at the same time, be acknowledged, that, when they are so assisted, they appear to enjoy this sense in great perfection. A bee will recognise its habitation from great distances, and distinguish it at once from many others in a numerous apiary. It passes through the air in a straight line towards its object with extreme rapidity. On quitting the hive, it flies towards the field which is most in flower; and as soon as it has determined on its course, it takes as direct a line as a ball issuing from a musket. When it has collected sufficient provision, it rises in the air to discover its hive, and then darts forward with the velocity of an arrow, and with unerring precision in its aim.

Perceptions of Temperature.

Their perceptions of heat and cold, which are generally referred to the sense of touch, appear to be extremely delicate. In several experiments of Huber's, the influence of the rays of the sun excited them to a vigorous action of the wings. It is well known, that great cold reduces them to a state of torpor, and inferior degrees of cold are evidently unpleasant to them. They show by their conduct that they are sensible of alterations in the state of the weather for some time before we can perceive them. Sometimes, when working with great assiduity, they will suddenly desist from their labours; none will stir out of the hive, while all the working-bees that are abroad hurry home in crowds, and press forward so as to obstruct the entrance of the hive. Often when they are thus warned of the approach of bad weather, we can distinguish no alteration in the state of the atmosphere. Gathering clouds sometimes produce this effect on them; but perhaps they possess some species of hygrometrical sense, unconnected with any impression of vision. It is alleged that no bee is ever caught in a sudden shower, unless from some cause it has wandered very far from the hive, or been disabled by some accident from returning to it. There is reason for thinking, however, that much exaggeration has prevailed in the statements of authors as to the extent of this kind of foresight. Huber supposes that it is the rapid diminution of light that alarms them, for if the sky be uniformly overcast, they proceed on their excursions, and even the first drops of a soft shower do not make them return with any great precipitation.

Taste.

Their taste is perhaps the most imperfect of their senses. They exert hardly any discrimination in the collection of honey from different flowers. They are not repelled by the scent or flavour of such as are extremely offensive to our organs, and scruple not to derive supplies from such as are highly poisonous. In some districts in America, it is well known that the honey acquires in this way very deleterious properties. The qualities of honey are, indeed, observed to vary much, according to the particular situation from which it is obtained. The most stagnant and putrid waters, as we have already noticed, are resorted to by bees with the same avidity as the purest. In their selection of flowers they are guided by the quantity of honey they expect to meet with, and in no respect by its quality. When the scythe has cut

down all the flowers which before yielded them a plentiful supply, they discontinue their excursions, although the weather be in all respects propitious. Their smell must, therefore, be sufficiently acute to enable them to discover the presence of honey at great distances. Direct experiment has, indeed, proved this to be the case. Mr Huber found that they proceeded immediately towards boxes, which contained honey concealed from their view; and such, in fact, is the situation of the fluid of the nectaria in flowers. Some odours, especially the fumes of tobacco, and indeed all kinds of smoke, are highly obnoxious to them; this is the case, also, with the smell of oil of turpentine, alcohol, ammonia, the nitric and muriatic acids, and several other volatile chemical agents, upon receiving the impressions of which, they immediately set about ventilating themselves in the manner above described. But nothing excites their displeasure in a greater degree than the breath of the spectator; as soon as they feel which, they show signs of anger, and prepare to revenge it as an insult. The odour of the poison of their sting produces similar effects, exciting them to immediate rage and hostility.

Although it is sufficiently clear that many insects smell, yet the particular organ of this sense has never been accurately ascertained; and the opinions of naturalists have been much divided on this subject. These opinions have been supported more by arguments drawn from the analogy of what happens in other classes of animals, than by any direct experiments on insects themselves. We know that, in all animals respiring by means of lungs, the organs of smell are placed at the entrance of the passages of the air; and it has often been concluded, that, in like manner, the stigmata, or the orifices of the air tubes, were the seat of this sense in insects. By others, the antennæ have been assigned as the organs, through which these impressions were conveyed to the sensorium. The experiments of Huber have proved that neither of these opinions is correct; and have satisfactorily shown, that in the bee this sense resides in the mouth itself, or in its immediate vicinity. Here, indeed, would be its proper station, if this faculty be intended, as we may reasonably suppose it to be, to apprise the individual of the qualities of the food, prior to its being eaten. When the mouth of the bee was plugged up with paste, which was allowed to dry before the insect was set at liberty, it remained quite insensible to the same odours, at which it had before manifested the strongest repugnance.

It is generally supposed that bees possess the sense of hearing. The common practice of making a loud noise by drums and kettles in order to attract a swarm is founded on this supposition. But the evidence is by no means conclusive; for we find that they are nowise disturbed by a loud clap of thunder, or by the report of a gun, or any other noises that may happen to arise around them. It is, however, certain, that they are capable of emitting a variety of sounds, which appear expressive of anger, fear, satisfaction, and other passions, and it would seem that they were even capable of communicating certain emotions to one another in this manner. Huber

Bee.

Bee.

observed, that the queens, during their captivity, sent forth a peculiar sound, which he supposes to be a note of lamentation. A certain cry, or humming noise from the queen, will strike with sudden consternation all the bees in the hive; and they remain for a considerable time motionless and stupified. Hunter has noticed a number of modulations of sound emitted by bees under different circumstances, and has instituted an inquiry concerning the means employed by them in producing these sounds, for an account of which we shall refer the reader to his paper in the *Philosophical Transactions*.

Instincts of Bees.

If the function of sensation in insects be involved in doubt and obscurity, the knowledge of those more interior faculties which are the springs of voluntary action is hid in still deeper mystery. Buffon refuses to allow bees any portion of intelligence, and contends that the actions we behold, however admirably they are directed to certain ends, are in fact merely the results of their peculiar mechanism. Other philosophers, such as Reaumur, have gone into the opposite extreme, and have considered them as endued with extraordinary wisdom and foresight,—as animated by a disinterested patriotism,—and as uniting a variety of moral and intellectual qualities of a higher order. The truth, no doubt, lies between these overstrained opinions; but it is extremely difficult to decide in what degree these respective principles operate in the production of the effects we witness. We have been too long in the habit of sheltering our ignorance of the causes of this class of phenomena, by referring them indiscriminately to what is called *instinct*, to submit to a cautious and patient investigation of the hidden springs of action. The term *instinct* should properly be regarded, not as denoting a particular and definite principle of action, whose operation we can anticipate in any new or untried combination of circumstances, but as expressive of our inability to refer the phenomena we contemplate to any previously known principle. Thus the actions which an animal performs in obedience to the calls of appetite, are not properly said to be instinctive; nor can the term be applied to actions, which are the consequence of acquired knowledge, and of which the object is with certainty foreseen by the agent. But when an animal acts apparently under a blind impulse, and produces effects useful to itself or to the species, which effects it could not have previously contemplated as resulting from those actions, it is then customary to say, that it is under the guidance of instinct, that is, of some unknown principle of action. It will be proper, therefore, to keep this distinction in view, in judging of the voluntary actions of the lower animals.

In no department of natural history is it more necessary to be aware of the proper import of the term *instinct*, than in studying the phenomena presented by the bee; for nowhere is it more difficult to discriminate between the regular operation of implanted motives, and the result of acquired knowledge and habits. The most striking feature of their history, and the one which apparently lays the foundation for those extraordinary qualities, which raise them above the level of other insects, is the disposi-

tion to social union. It may in general, indeed, be remarked, that animals which associate together so as to form large communities, display a higher degree of sagacity than those who lead a solitary life. This is especially observable among insects. The spider and *Formica leonis* may exhibit particular talents, or practise particular stratagems in the pursuit and capture of their prey; but their history is limited to a single generation, and embraces none of those interesting relations, which obtain between individuals composing the gregarious tribes, such as the ant, the wasp, and the bee. Among these we trace a community of wants and desires, and a mutual intelligence and sympathy, which lead to the constant interchange of good offices, and which, by introducing a systematic division of labour, amidst a unity of design, leads to the execution of public works on a scale of astonishing magnitude. The attachment of bees to their hive, which they defend with a courage and self devotion truly admirable; their jealousy of intruders; their ready co-operation in all the labours required for the welfare of the community; their tender care of their young; the affection and homage which they bestow on their queen, and which they manifest on all occasions in the most unequivocal manner,—imply qualities such as we could hardly persuade ourselves could animate a mere insect, on which we are in the habit of proudly looking down as placed in one of the lowest orders of created beings.

We shall content ourselves, at present, with these general observations, as the instances which serve to illustrate their moral and intellectual character belong properly to the history of the different processes they follow in the construction of their combs, the hatching and rearing of their progeny, and the mode of conducting their migrations. To these subjects, therefore, we shall now proceed: and in order to present the most connected and complete account of their economy, we shall begin the history from the period when a new swarm has just occupied a hive, and when all the arrangements for their habitation, and the construction of the cells in which their eggs and provisions are to be deposited, are yet to be effected.

The first care of the labouring-bees, on their settlement in their new abode, is to clean it out thoroughly. While one set of bees is thus employed, another is distributed about the country, in order to procure the proper materials for blocking up the small holes and chinks of the hive, and for laying a firm foundation for the edifice, which is to be constructed within it. The substance which is principally employed in this preliminary stage is *Propolis*, a species of glutinous resin of an agreeable aromatic odour, and reddish brown colour, in process of time becoming darker, and acquiring a firmer consistence. According to the analysis of Vauquelin (*Mém. Soc. Agricult. Departem. Seine*), it is composed chiefly of resin, with a small proportion of wax, and of acid, and aromatic principles. It is soluble in alcohol, ether, and oils, both fixed and volatile; and tinges the solvent of a beautiful red colour. Cadet has since ascertained in it the presence of benzoic and gallic acids. Reaumur had not been able to dis-

Bee.

Preparation of the Hive.

Nature and Origin of Propolis:

Bee. cover from what plants the bees collect this substance. Riem asserts, that it is chiefly from pines and other trees of the fir kind. The recent observations of Huber have assisted in the solution of this question. On placing branches of the wild poplar tree before the hive, he found that the bees eagerly seized upon the varnish which exudes from the buds; and examining the chemical properties of this varnish, he identified it with the propolis, with which the inside of the hive is lined.

Mode of its Application.

The propolis adheres so strongly to the legs and feet of the bee which has collected it, that it cannot be detached without the assistance of its fellow labourers. For this purpose the bee that is loaded presents its legs to the workers in the hive, which carry off with their jaws this adhesive substance, and immediately apply it, while yet ductile, all round the interior of the hive, and particularly over all the projecting parts; hence its name, of Greek derivation, signifying *before the city*. In like manner all the foreign bodies that are introduced into the common habitation, and are too heavy to be removed, are covered over with this resinous substance. If a snail, for instance, should happen to introduce itself into the hive, after dispatching it with their stings, they encrust it over with propolis. Mr Knight has observed that, besides propolis, bees will occasionally carry home, and employ as cement, other substances, having the same glutinous properties. He frequently covered the decorticated parts of trees, on which he was making experiments, with a cement composed of bees-wax and turpentine; and in the autumn, has observed a great number of bees occupied in carrying off this substance. They detached it from the tree with their forceps, and the little portion thus obtained was then transferred by the first to the second leg, by which it was deposited on the thigh of the third, precisely in the same manner as the pollen of flowers is collected and transferred. Whilst the bees were employed in the collection of this substance, Mr Knight had many opportunities of observing the peaceful and patient disposition of them as individuals, which Mr Hunter had also, in some measure, noticed. When one bee had collected its load, and was just prepared to take flight, another often came behind it, and despoiled it of all it had collected. A second, and even a third load was collected, and lost in the same manner; and still the patient insect pursued its labour, without betraying any symptoms of impatience or resentment. When, however, the hive is approached, the bee appears to be the most irritable of all animals, and is animated with the most vindictive spirit against a public enemy, without displaying any peculiar hostility in the revenge of a private injury.

Construction of the Combs.

The next object of their labours is to prepare the combs, which are to be the receptacles for the eggs, with which the queen is pregnant, and which are now about to be laid. The material employed for this purpose is not propolis, but wax; the production of which, by secretion from a particular set of bees, who feed largely upon honey, was formerly explained. The bees are, for this purpose, actively employed in collecting honey, and in imparting it to their companions in the hive, who, when they have filled their

crops with it, hang together in a thick cluster from the top of the hive, and thus remain in a state of inactivity for a considerable period. During this time, the secretion of wax is proceeding, and may be seen collected in laminae under the abdominal scales, whence it is removed by the hind-legs of the bee, and transferred to the fore-legs, and from thence taken up by the jaws. In this operation, they are often assisted by their companions, who even directly seize upon the wax from under the abdomen of those who are before them. When a sufficient quantity of materials has thus been collected together, the process of building is commenced. But, in order to understand the subsequent operations, it is necessary to have a correct idea of the form of the cells which compose the combs. We shall, therefore, proceed to give some account of their structure when they have attained their perfect state.

Bee.

The combs of a bee-hive are formed into parallel and vertical strata; each of which is about an inch in thickness, the distances between the surfaces of each being about half an inch, an interval which serves for the passage of the bees over both surfaces. They generally extend the whole breadth of the hive, and often descend the whole length, from the top to the bottom. They consist altogether of thin partitions, which inclose hexagonal cells about half an inch in depth, and a quarter of an inch in diameter, opening on both surfaces of the comb, and closed by a partition common to those on both sides, and which occupies the middle distance between the two surfaces. This partition is not, however, a plane, but is composed of a collection of rhombs. Three, and sometimes four of these rhombs, inclined to one another at a certain angle, form the bottoms of each cell, which thus has the shape of a flattened pyramid, of which the basis is towards the mouth of the cell. The geometric form of each individual cell is, therefore, a hexagonal prism, terminated by a trihedral pyramid; the three sides of which pyramid are rhombs, which meet at the apex by their obtuse angles, and, forming oblique angles with the sides of the prism, truncate a portion of these, and convert them from rectangles, which they would be in a regular prism, into trapeziums. Of the two angles of these trapeziums, adjoining to the base of the pyramid, one must be acute and the other obtuse; the acute angle of one trapezium being next to the acute angle of the adjoining trapezium, and the obtuse angle being in like manner next to another obtuse angle of the preceding trapezium; so that, in going round the base, we meet with pairs of acute and of obtuse angles alternately succeeding each other. The two adjoining acute angles of the trapezia are adjoining to two of the terminal rhombs, which here present their acute angles; so that at these points a solid angle of four planes is formed, all the angles being acute. Each pair of obtuse angles of the trapezia, on the other hand, are adjacent to the obtuse angle of one of the rhombs only; thus composing a solid angle of three planes, of which the angles are all obtuse, and these two kinds of solid angles succeed one another alternately all round the base of the pyramid; there being three of each kind, and six in all. The axis of each cell coincides, not with

Form of the Combs.

the axis of the cell on the opposite surface, but with one of its angles, so that each of the three obtuse angles, at the base of the terminal pyramid, corresponds to the central parts of three of the cells on the opposite side; and each of the sides of the pyramid, which closes a cell on one side, contributes, in part, to the closing of three of the cells on the opposite side. We may easily satisfy ourselves that this is the case, by piercing the centres of each of the three planes which close the bottom of a cell, with a small pin, when, on turning the comb, the three pins will be found to have passed into three different cells on the opposite side.

Geometric
Properties
of the Cells.

A structure of this kind is obviously the one of all others calculated to afford the greatest space for each cell, with the same expence of materials. It is easy to perceive, in the first place, that, in a plane surface, when a number of small spaces are to be divided by partitions, the hexagonal form is the one which comprehends the largest space compatible with the extent of the lines which inclose them. For the equilateral triangle, the square, and the regular hexagon, are the only regular forms that admit of being joined together in the same plane without leaving interstices; and the proportion of the area to the periphery in every polygon, increases as the figure consists of a greater number of sides, and is therefore greater in the hexagon than in any of the other two. The truth of this proposition was perceived by Pappus, and even its application to the subject of the honeycomb was made by that ancient geometrician. But the determination of the form and inclination that should be given to the partitions which close the bottoms of the cells, and which may of course belong equally to those on both sides of the comb, is a problem much more complicated and difficult of solution. It has exercised the skill of several modern mathematicians of great eminence; and has generally been resolved by the assistance of the infinitesimal calculus, or the methods of maxima and minima. A mistake has sometimes been committed in supposing that the capacity of the cells would be affected by varying the inclination of the partitions, whereas, if abstraction be made of the thickness of these partitions, all the space which is gained on the one side must be obtained at the expence of the space on the other, and the sum total will therefore remain the same. This error has been pointed out by Le Sage of Geneva, and also by others. The whole question, therefore, resolves itself into that of the form producing the greatest saving of materials. Kœnig, the pupil of the celebrated Bernouilli, calculated that the angles of the rhombs, which should answer this condition, must be $109^{\circ} 26'$, and $70^{\circ} 34'$. Cramer, professor of mathematics in the University of Geneva, has given a very elegant demonstration of this problem, from which it results that the obtuse angle of the rhomb must be such, that its half has for its tangent the square root of 2. This is the case with the angle $54^{\circ} 44' 8''$; the two angles of the rhomb are therefore $109^{\circ} 28' 16''$, and $70^{\circ} 31' 44''$. It follows, also, that the two diagonals of this rhomb are to one another in the same proportion as the side and diagonal of a square, that is, as 1 to 1.41421356237 ,

&c. It is also another consequence from the same data, that the angles of the trapezia forming the sides of the hexagonal prism adjacent to the rhombs, are precisely equal to those of the rhombs themselves, and that the solid angle formed at the apex of the pyramid, and which is composed of those equal obtuse angles, is precisely equal to each of the three angles at the base, which are also formed of three obtuse angles. It is also true that these are the only angles which will give this perfect equality. Maraldi had already made the same remark; and assuming this principle of the equality of the angles as the basis of this reasoning, had calculated them on this hypothesis, making them $109^{\circ} 28'$ and $70^{\circ} 32'$, which is nearly accurate. To the same author we are indebted for the comparison of the results of theory with fact, by the admeasurement of the actual angles of the honeycomb; these he states to be about 110° and 70° , which is as near an agreement with theory as could well be expected.

Boscovich, who has also given a solution of the same problem, conceives that the equality of inclination of the planes gives greater facility to the construction of the comb, and might, therefore, be a motive of preference, independently of the greater economy of wax. Maclaurin has exercised his abilities in resolving this problem, and has demonstrated, by simple geometry, that the most advantageous form is that which results from the supposed equality of the three plane angles forming the solid angles at the base. He estimates the saving of wax by partitions so constructed, above what would be required for a flat partition, at one-fourth of the wax, which would be wanted to complete the truncated sides of the cells, so as to form them into rectangles. L'Huilier, in the *Memoirs of the Berlin Academy*, has given a demonstration which is remarkable for its simplicity, and for its involving none but elementary propositions; he values the economy of wax at $\frac{1}{4}$ of the whole wax employed. Le Sage, as appears from the life of that philosopher by Professor Prevost, has shown that this celebrated problem reduces itself to the finding the angle at which two planes with a given inclination (such as 120°) can be cut by a third plane, so as to make all the angles resulting from the section equal to one another.

But a more essential advantage than even the economy of wax results from this structure, namely, that the whole fabric has much greater strength than if it were composed of planes at right angles to one another; and when we consider the weight they have to support when stored with honey, pollen, and the young brood, besides that of the bees themselves, it is evident that strength is a material requisite in the work.

It has often been a subject of wonder how such diminutive insects could have adopted and adhered to so regular a plan of architecture, and what principles can actuate so great a multitude to co-operate by the most effectual and systematic mode in its completion. Buffon has endeavoured to explain the hexagonal form by the uniform pressure of a great number of bees, all working at the same time, exerting equally in all directions in a limited space; and illustrates his theory by supposing a number of similar

Buffon's
Theory of
the Form
tion of the
Combs

Bee. cylinders compressed together, and taking the form of hexagonal prisms by the uniform expansion of each. The analogy of the forins produced by the law of crystallization,—of the figures assumed by various parts in the animal and vegetable world, such as the skin of the bat, the inner coat of the second stomach of ruminant quadrupeds,—is also adduced by this captivating, but superficial writer, in support of his argument. However plausible this theory may at first sight appear, it will not stand the test of a more serious examination. The explanation he has attempted applies no farther than to the inclination of the sides of the cells; but he did not take into account, perhaps from not having studied the subject mathematically, the inclinations and forms of the planes which close each cell, and so curiously conspire on both sides to serve a similar office, while they at the same time accurately fulfil a refined geometrical condition. But it is sufficient confutation of the whole theory to show, that it is directly at variance with the actual process employed by the insects in the construction of their combs.

**Mode of
their Con-
struction.**

It might be supposed that bees had been provided by nature with instruments for building of a form somewhat analogous to the angles of the cells; but in no part, either of the teeth, antennæ, or feet, can any such correspondence be traced. Their shape in no respect answers to that of the rhombs, which are constructed by their means, any more than the chisel of the sculptor resembles the statue which it has carved. The shape of the head is, indeed, triangular, but its three angles are acute, and different from that of the planes of the cells. The form of the plates of wax, as they are moulded in the pouches into which this substance is secreted, is an irregular pentagon, in no respect affording a model for any of the parts which compose the honeycomb. Hunter, observing that the thickness of the partition was nearly equal to that of the scale of wax, thought that the bees apply these scales immediately to the formation of the partition, by merely cementing them together. Reaumur, notwithstanding the use of glass hives, had not been able to discover the mystery of their process of architecture; but inferred, from what he saw, that the wax was rejected from the stomach in the form of a white frothy liquor. No naturalist, indeed, prior to Huber, had been able to follow these insects in their labours, on account of their crowding together in a thick mass while they are building; but the expedients resorted to by that ingenious philosopher have unfolded the whole process, which he has given with great detail in the second volume of his *Observations sur les Abeilles*. Huber witnessed the whole of their actions, and saw that each bee drew out, with its hind feet, one of the plates of wax from under the scales where it was lodged, and, carrying it to the mouth in a vertical position, turned it round, so that every part of its edge was made to pass in succession under the cutting edge of the jaws; it was thus soon divided into very small fragments, while at the same time a frothy liquor was poured upon it from the tongue, so as to form it into a perfectly plastic mass. This liquor gave the wax a whiteness and opacity which it did not possess originally, and rendered it at the same time tenacious and

Bee. ductile. A quantity of wax thus prepared for use is accumulated, and applied to further the work in the manner we are presently to describe.

But, in considering the process by which the comb is formed, a circumstance should be pointed out, which seems not to have been particularly noticed by any author except Huber; and yet it is one of essential importance in studying their process of architecture,—it is, that the first row of cells, on either side, are of a form very different from that of the subsequent rows. As they take their origin from a plane surface, two of the sides necessary to complete the hexagon are cut off by this plane, so that the general form of the orifice is pentagonal; and the bottom of the cells on one side are composed of two equal rhombs only, and, on the other side, of two trapezoidal planes, with one rhomb. Such a modification of shape was necessary, in order to prepare the way for the regularly formed cells which were to follow.

The foundations of the combs are laid by the bees raising a solid block or plate of wax, of a semicircular form. In this they scoop out a small vertical channel, of the size of an ordinary cell. The sides of this channel are then strengthened by additions of wax. On the opposite side, two other channels are formed, one on each side of the plane opposite to the former channel. The extremities of these channels, which at first present a curved outline, are then fashioned into straight walls, forming an angle at each vertex. The bottom of each cell being thus sketched out, the design is completed by raising walls round the sides. Different bees generally work on the opposite sides at the same time, and appear to have some perception of the thickness of the partitions, and of the situation of the opposite walls, in which they are perhaps guided by slight prominences, occasioned by the depressions which correspond to them on the other side; and they scrape off the wax in those places where its thickness is greatest; that is, where the bees on the other side had accumulated materials. In this way, then, in constructing the successive rows, the axis of each cell will be found to occupy the most retiring parts of the partition, and will be opposite to the junction of three of the opposite cells.

Soon after the bees have completed the foundations, and constructed a few of the cells of the central comb, they begin two others, one on each side, at the proper distance, and in this manner continue to form others in succession, in proportion as the former are advanced. Their object, at first, seems to be, to extend the surface of the work, so as to admit of the greatest possible number of workers being employed at one and the same time. In this way, then, the work proceeds from all points at once, new cells being begun before the former are completed, so that the whole comb, while it is in progress of construction, has a semi-lenticular shape, broader at the top, and tapering below and towards the sides. It extends downwards, however, more rapidly than in any other direction, and its surfaces do not become parallel to each other, till the last stage of the building process. When this is completed, the whole is further strengthened by an additional coating

Bee.

of propolis, round the margin of all the cells; and the junctions of every plane, both of the sides and bottoms of the cells, are also soldered together by a lining of the same substance. The edges of the combs are also secured in their situations by being glued to the side of the hive, and supported by fresh abutments of propolis. Sometimes a mixture of wax and propolis, manufactured by the bees themselves, is employed as the cementing material. The first coating of this compound substance is denominated *Commosis* by Pliny, and described as having a bitter taste; the second, or the *Pissoceros* of the same author, is stated to be of a thinner consistence, and more adhesive than the former; while the third substance or propolis is completely solid.

The cells recently constructed are perfectly white, but in a short time they are found of a yellow tint, which becomes gradually deeper, and when very ancient gives them a dark brown cast. It is therefore easy to distinguish in a hive the successive periods of formation of different portions of the combs. From the researches of Huber, it appears, that these variations of colour are not owing to any changes in the wax itself, but to additional coatings of a peculiar varnish, consisting of propolis and a colouring matter. The latter differs materially from propolis, being wholly insoluble in alcohol. It loses its colour by the action of nitric acid, or the light of the sun. Its origin has not yet been discovered; nor has the mode in which it is applied been clearly made out; although Huber presumes, from his observations, that they spread it by means of their mandibles, which he has seen them rub against the sides of the cells, while they acquired a yellow colour from the operation.

Different
Kinds of
Cells.

Such is the general outline of the architectural labours of the bee. A number of modifications are however met with, adapting them to various purposes and to new circumstances. The cells are required to be of different sizes for the reception of different sorts of eggs and larvæ. The smallest, which are also the most numerous, are appropriated to the eggs of the working-bees; a larger sort receive those of the males; and a small number of very large cells are destined for the education of the young queens, and are therefore called royal cells. The first set are generally $5\frac{1}{2}$ lines in depth, and $2\frac{1}{2}$ in diameter; the second are from 7 to $7\frac{1}{2}$ lines in depth, and $3\frac{1}{2}$ ths in diameter; while the royal cells are above one inch deep, one-third of an inch wide, and their walls about one-eighth of an inch in thickness. Other cells, again, are set apart as magazines of honey, or of pollen; they are made twice as deep as the common cells, and their axes are inclined to the horizon, so that their mouths are in the highest part, and their liquid contents may be more easily retained. When these are filled, they are closed up by the bees with a wall of wax, and opened only when necessity requires.

The regularity of the cells is often disturbed in consequence of the admixture of rows of larger cells with those of smaller dimensions; but the pyramidal partitions are adapted by successive gradations to these changes; so that in many rows of what may be called cells of transition, the bottom

Cells of
Transition.

presents four planes instead of three, two being trapeziums, and the other two irregular hexagons. These irregularities are met with chiefly in the combs most distant from the central one. When an abundant supply of honey induces them to lay up a large quantity in store, they build up for this purpose the walls of common cells so as to give them a greater depth. The royal cells are often raised from the ruins of a number of other cells, which are destroyed to make room for them; they are usually built on the edge of some of the shorter combs, and often in the very centre of the hive. Sometimes there are but three or four of them; at other times eleven, or even fourteen, have been counted in the same hive. They are formed of a mixture of propolis and wax; their form is oblong, resembling that of a pear; their position is always vertical, so that when they arise from amidst other cells, they are placed against the mouths of those cells, and project beyond the common surface of the comb. They are perfectly smooth on the inner surface; while their outer side is covered with a kind of hexagonal fretwork, as if they were intended for the foundation of regular cells.

Bee.

As soon as a sufficient number of cells have been constructed, the queen begins to deposit her eggs. In those that have been impregnated the preceding year, the oviducts begin to swell early in the spring, so that by the month of March they are ready to come forth. The queen-bee is, therefore, the earliest breeder of any insect we are acquainted with. But the young queens are capable of laying eggs thirty-six hours after impregnation. It appears to be now well ascertained by the experiments of Huber, that she is aware of the nature of the eggs she is laying, and deposits each in the kind of cell adapted to receive it. She may be seen examining attentively the capacity of the cell before laying her egg. She passes thus from one cell to another, allowing herself hardly any interval of repose. She commonly lays two hundred eggs in a day; but if the weather be warm, and vegetation luxuriant, she will lay a much greater number. The cold of autumn suspends this process. The eggs first produced are those of labourers, and their deposition continues for ten or twelve days, during which interval, the working-bees are busily employed in constructing the larger cells. The queen next acquires a considerable increase of size, so as to walk with difficulty. She then lays male eggs in the large cells, during a period of from sixteen to twenty-four days. They are less numerous than the former eggs, in the proportion of one to thirty.

These industrious insects now set about constructing royal cells; and the queen-bee, having finished her deposition of male eggs, begins again to lay those of the common bees; and finding royal cells open for their reception, deposits a single egg in each, but only at intervals of one or two days; the common cells receiving those laid in the meantime. When the hive is not sufficiently numerous, or the season has been unproductive, no royal cells are formed; and the education of a queen is not attempted.

As soon as the eggs are deposited, the bees eagerly seek for that species of nourishment on which the larvæ.

Nourish-
ment of the
Larvæ.

Bee. larva is to be fed. This consists of pollen, with a proportion of honey and of water, which is partly digested in the stomachs of the nursing bees, and which is made to vary in its qualities according to the age of the young. Pollen is afforded by flowers in the spring in such abundance that the bees of a single hive will often carry home above a pound of this substance in one day. The eggs of bees are of a lengthened oval shape, with a slight curvature, and of a bluish white colour. They are hatched without requiring any particular attention on the part of the bees, except that of keeping up a proper temperature; in which case, three days are sufficient for the exclusion of the larva. The larva has the appearance of a small white worm without feet, which remains generally coiled up at the bottom of the cell. The nursing bees feed it with great assiduity, with the kind of jelly above described, and in every respect exhibit the greatest attachment for them. Mr Hunter says that a young bee-maggot might easily be brought up by any person who would be attentive to feed it. It may be seen opening its two lateral pincers to receive the food, and then swallowing it. As it grows up, it casts its cuticle, like the larvæ of other insects. In the course of five or six days, it has attained its full size, and nearly fills the cell in which it is lodged: it now ceases to eat, and the bees close up its cell with a covering of wax, or rather consisting of a mixture of wax and propolis, which they possess the art of amalgamating together. During the next thirty-six hours, the larva is engaged in spinning its cocoon; and in three days more, it is converted into the state of pupa or chrysalis. In this state it is perfectly white, and every part of the future bee may be distinguished through its transparent covering. In the course of a week, it tears asunder its investing membrane, makes its way through the outer wall of its prison, and emerges in its perfect form. Reckoning from the time that the egg is laid, it is only on the twentieth day of its existence that this last metamorphosis is completed. No sooner has it thus emancipated itself, than its guardians assemble round it, caress it with their tongues, and supply it plentifully with food. They clean out the cell which it had been occupying, leaving untouched, however, the greater part of the web, which thus serves to bind together still more firmly the sides of the comb. The colour of the bee, when it quits the cell, is a light grey; it requires two days before it can attain sufficient strength for flying. The metamorphoses of the male-bee follow the same progress, but require a few days longer for their completion, occupying about twenty-four days from the time of the egg being laid, to the attainment of the perfect state.

Process of rearing the Queen-Bee.

The eggs deposited in the royal cells are precisely similar to those of the working-bees, and might be substituted the one for the other. The larva arises from it precisely in the same manner, and does not differ from the larva of the workers. But the attention of the nursing bees is more incessantly bestowed on them; they are supplied with a peculiar kind of food, which appears to be more stimulating than that of ordinary bees. It has not the same mawkish taste, and is evidently acescent. It is furnished to

VOL. II. PART I.

Bee. the royal larva in greater quantities than it can consume, so that a portion always remains behind in the cell, after their transformation. The growth of the larva, and the development of all its organs, are very much accelerated by this treatment; so that in five days, it is prepared to spin its web; and the bees enclose it by building up a wall at the mouth of its cell. The web is completed in twenty-four hours; two days and a half are consumed in a state of inaction, and then the larva transforms itself into a pupa. It remains between four and five days in this state; and thus, on the sixteenth day after the egg has been laid, it has produced the perfect insect. When this change is about to take place, the bees gnaw away part of the wax covering of the cell, till at last it becomes pellucid from its extreme thinness. This must not only facilitate the exit of the fly, but may possibly be useful in permitting the evaporation of the superabundant fluids.

Rivalship of the Queens.

But the queen-bee, although perfectly formed, is not always at liberty to come out of her prison; for if the queen mother be still in the hive, waiting a favourable state of the weather to conduct another swarm, the bees do not suffer the young queens to stir out, they even strengthen the covering of the cell by an additional coating of wax, perforating it with a small hole, through which the prisoner can thrust out its trunk, in order to be fed by those who guard it. The royal prisoners continually utter a kind of plaintive song, the modulations of which are said to vary. One consequence of their detention is, that they are capable of flying as soon as they are set at liberty. But the motive of this proceeding, on the part of the bees who guard them, is to be found in the implacable hatred which the old queen bears against all those of her own sex, and which impels her to destroy without mercy all the young queens that come within her reach. The working bees are, on this account, very solicitous to prevent her even approaching the royal cells, while there is any prospect of a swarm being about to take place. They establish themselves as a guard around these cells, and, forgetting their allegiance on this occasion, actually beat her off as often as she endeavours to come near them. If, on the other hand, the swarming season is over, or circumstances prevent any farther swarms from being sent off, the bees do not interpose any obstacle to the fury of the old queen, who immediately begins the work of destruction, transfixing with her sting, one after the other, the whole of the royal brood, while they are yet confined in their cells. It is observed by Huber, that the royal larvæ construct only imperfect cocoons, open behind, and enveloping only the head, thorax, and first ring of the abdomen; and conceives that the intention of nature in this apparent imperfection, is that they may be exposed to the mortal sting of the queen, to whom they may be given up as a sacrifice.

When the old queen has taken her departure along with the first swarm, the young queens are liberated in succession, at intervals of a few days, in order to prevent their attacking and destroying one another, which would be the infallible consequence of their meeting. This exterminating warfare is

F f

Bee.

prevented by the vigilance of the bees who guard them, so long as new swarms are expected to take place. When a young queen is liberated, she is, like others of her sex, anxious to get rid of her rivals, and even at that early age seeks to destroy her sisters, who are still confined in the other royal cells; but as often as she approaches them she is bit, pulled and chased without ceremony by the centinels. But when the season is too far advanced for swarming, or when the hive is too much exhausted in its population by the swarms that have already been sent off, they no longer interfere in preserving peace, and the first that acquires her liberty proceeds to the massacre of all her rivals. If two or more queens should happen to issue out at the same moment, they mutually seek each other, and fight till one is killed; and the survivor is immediately received as the sovereign of the hive. The bees, far from seeking to prevent these battles, appear to excite the combatants against each other, surrounding and bringing them back to the charge when disposed to recede from each other; but when either of the queens shows a disposition to approach her antagonist, all the bees forming the clusters instantly give way to allow her full liberty for the attack. The first use which the conquering queen makes of her victory is to secure herself against fresh dangers by destroying all her future rivals in the royal cells; while the other bees, who are spectators of the carnage, share in the spoil, greedily devouring any food which may be found at the bottom of the cells, and even sucking the fluid from the abdomen of the pupæ before they toss out the carcasses.

Impregnation.

The impregnation of the queen-bee was formerly involved in the deepest obscurity, and has given rise to a multitude of very fanciful opinions. Some have denied that any intercourse with the male was necessary for the fecundation of the eggs. Swammerdam supposed that the mere effluvia proceeding from the males, where they were collected in clusters, was sufficiently active to produce this effect, by penetrating the body of the female. Huber proved, by a decisive experiment, that no such consequence resulted from these effluvia. Maraldi imagined that the eggs were fecundated by the drones, after being deposited in the cells, in the same way that the spawn of fishes is rendered prolific by the milters. Mr Debray of Cambridge, in a paper published in the *Philosophical Transactions*, of which an account is given under the article BEE, in the *Encyclopædia*, fancied that he had seen the milt-like fluid in the cells. But this appearance has been shown by Huber to be a mere optical illusion, arising from the reflection of light at the bottom of the cell. When the males are excluded from the hive, the queen is as fertile, and the eggs as prolific, as when they are present. Hattorff supposed that the queen is capable of impregnating herself; an opinion which was supported by Schirach and Wilhelmi, and was even favourably received by Bonnet, as it in some measure accorded with his discoveries respecting the Aphis, of which our readers will find an account in the article APHIS. (See *Encyclopædia*.) Linnæus was of opinion that an actual union between the sexes took place, and Reaumur fancied that he

had seen this happen within the hive. There is, however, great reason to think that he was mistaken. Huber has clearly proved that the queens are never impregnated as long as they remain in the interior of the hive; and, if confined within it, continue barren, though surrounded by males. It is only during her flight, at a considerable height in the air, that the male has complete access to her so as to effect the impregnation. In half an hour the queen-bee returns to the hive with unequivocal proofs of the intercourse that has taken place, for she has in fact robbed the drone of the organs concerned in this operation; and the drone, thus mutilated, is left to perish on the ground. From its being necessary that the queen should fly to a distance in order to be impregnated, Huber infers the necessity of a great number of drones being attached to the hive, that there may be a sufficient chance of her meeting one of them during her aerial excursion.

Bee.

We are now to direct our attention to the migrations of bees, by which new colonies, similar to that for which they had originally peopled the parent hive, are founded. The final causes of this phenomenon are sufficiently obvious; but it does not so clearly appear to what circumstances it is immediately owing. The increasing population of a hive probably occasions inconvenience from the want of room, the increase of heat, and the greater vitiation of the air; inconveniences which become still more serious as the summer advances. The spring is accordingly the commencement of the swarming season; no swarm, indeed, will ever take place while the weather is cold, nor until the hive is well-stocked with eggs of every kind. The queen-bee, in consequence of the great number of eggs she has been laying, is now reduced to a more slender shape, and is well fitted for flight. Her aversion for the royal brood, which she seems to foresee will in no long time become able to dispute the throne with her, and the vain attempts she makes to destroy them in the cradle, in which she is invariably repelled by the bees who guard them, produce in her a constant restlessness and agitation, which, as Huber represents it, rises to a degree of delirium. This frenzy, from whatever cause it may originate, is communicated to the workers; they may be seen hurrying to and fro in the combs, with evident marks of impatience; the heat of the hive is increased by their tumultuous movements; it sometimes rises suddenly, on these occasions, from 92° to above 104°. A general buzz is heard throughout the hive. This state recurs from time to time, for some days before the swarm is actually on the wing; and the interval is occupied in making preparations for the approaching expedition. Provisions are collected in greater quantity by the working-bees. Mr Hunter killed several of those that came away, and found their crops full, while those that remained in the hive had their crops not near so full. Scouts are sent out to look for a proper habitation. Mr Knight, in the *Philosophical Transactions*, gives us a curious account of his observations on their manœuvres in this respect. In the cavity of a hollow tree, which, by the application of a board, had been fitted up for the reception of the swarms, he constantly ob-

Bee. served "that, about fourteen days previous to their arrival, a small number of bees, varying from twenty to fifty, were every day employed in examining, and apparently in keeping possession of the cavity; for if molested, they showed evident signs of displeasure, though they never employed their stings in defending their proposed habitation. Their examination was not confined to the cavity, but extended to the external parts of the tree above; and every dead knot particularly arrested their attention, as if they had been apprehensive of being injured by moisture, which this might admit into the cavity below; and they apparently did not leave any part of the bark near the cavity unexamined. A part of the colony, which purposed to emigrate, appeared in this case to have been delegated to search for a proper habitation; and the individual who succeeded must have apparently had some means of conveying information of his success to others; for it cannot be supposed that fifty bees should each accidentally meet at, and fix upon the same cavity, at a mile distant from their hive, which Mr Knight has frequently observed them to do, in a wood where several trees were adapted for their reception; and, indeed, he observed, that they almost uniformly selected that cavity, which he himself thought was the best adapted to their use. It not unfrequently happened, that swarms of his own bees took possession of these cavities, and such swarms were in several instances followed from his garden to the trees; and they were observed to deviate very little from the direct line between the one point and the other, which seems to indicate that those bees, who had formerly acted as purveyors, now became guides."

**Departure
of the
Swarm.**

On the day on which the swarm quits the hive, few of the workers roam to any distance, but several are seen performing circles in the air round the hive. The noise is on a sudden hushed; and all the bees enter the hive; this silence announces their immediate departure. A few workers appear at the door, turn towards the hive, and striking with their wings, give, as it were, the signal for flight. All those who are to accompany the expedition rush towards the door, and issue forth with wonderful rapidity, rising in the air and hovering for sometime, as if in order to wait for the assemblage of the whole troop. Then, following the motions of the queen, they settle wherever she alights, forming a dense cluster around her. Sometimes, from weakness, or other cause, she returns back to the hive, and is immediately attended thither by the rest. But if the weather be fine, the expedition is only deferred for one or two days, and again takes its departure. If their return be owing to the loss of their queen, they remain a fortnight or longer before the attempt to migrate is renewed, and then the swarm is much larger than before, which renders it probable that they have waited for the queen that was to go off with the next swarm. Sometimes when every thing indicates an approaching emigration, the passage of a cloud across the sun will suspend all their operations, and the previous bustle gives place to a state of perfect calm. But, if the day be not far advanced, the breaking out of sunshine will renew the commotion, and determine the moment of actual flight.

Bee. The swarm having rested for some time on the first landing-place, and collected the whole of its numbers, soars again in the air, keeping in a close phalax, and directing its course with great velocity to the spot which their guides had selected; giving out, at the same time, a loud and acute toned hum by the action of their wings.

The parent hive, thus deserted by its queen and a large proportion of its inhabitants, is busily occupied in repairing its loss. The bees which remain quietly pursue their labours; the young brood, soon arriving at maturity, quickly fill up every deficiency; and young queens, being allowed their liberty, one after the other, conduct in their turns new swarms, in the same manner as the first. The second swarm is not sent off till after the space of from five to ten days after the first. The following swarms succeed quicker to each other, but consist of smaller numbers than the earlier ones. If it happen that two queens are found in a swarm, either the swarm divides itself into two, and have separate destinations, or a single combat between the queens decides on which of them the empire is to devolve. Sometimes, indeed, they appear not to perceive each other, and the parties belonging to each construct separate combs within the same hive; but no sooner do these combs come in contact, and thus give occasion to the queens meeting each other, than the contest begins, and it does not terminate but by the death of one of the rival queens. Successive swarms are sent off so long as the increase of population admits of it, and the numbers thus produced in a season depends on a variety of circumstances, such as the abundance of flowers, and the warmth of the climate, and the capacity of the hive. Bosc, while he was French consul in Carolina, found a hive in the woods which had been robbed of its wax and honey by the negroes; he contrived to convey the bees in his hat to a hive in his garden; he obtained from this hive eleven swarms before the end of autumn; and these again afforded him the same number of secondary swarms, so that, by the end of the year, he had twenty-two hives stocked from the one he had thus saved from destruction. In this country, a hive commonly sends off only two, and sometimes three swarms in the course of the summer.

Very few drones accompany the new colonies; **Massacre of the Drones.** so that almost all those produced in the spring remain in the hive. But when the queens are impregnated, and no new swarms are about to take place, the workers, who had till then suffered them to live unmolested in the hive, are on a sudden seized with a deadly fury towards them, and a scene of carnage ensues. This usually happens in Jul, or August. They chase their unhappy victims in every quarter, till they seek a refuge at the bottom of the hive, where they collect in crowds, and are indiscriminately, and without a single exception, massacred by the working-bees, who, with implacable fury, transfix them with their stings, and throw the dead bodies out of the hive. So great is their antipathy to all the race of drones, that they destroy, at the same time, the male eggs and larvæ, and tear open the cocoons of their pupæ, in order to devote them to one common destruction. This sacrifice of the

Bee.

males is not, however, the effect of a blind and indiscriminating instinct; for if a hive be deprived of its queen, the massacre does not take place, while the hottest persecution rages in all the surrounding hives. In this case the males are allowed to survive one winter.

Provision for the Winter.

Having thus got rid of the useless mouths, which consumed, without any advantage to the public, a large portion of their provisions, the bees spend the remainder of the summer in collecting stores of honey and of pollen for the ensuing winter. Their gleanings are now less abundant than in the spring, and require more labour in the search and collection. But at this season, the leaves of many kinds of trees, which are covered in the morning with a saccharine fluid that transudes through them, furnish them with a species of nourishment, which, though of very inferior quality to the fluid of the nectaria, still contributes to their support. Fruit is also attacked by bees, after the cuticular covering has been broke through by birds or snails. They also find nutriment in the *Honey-dew*, which is an excrementitious fluid from the *Aphis*. (See that article). Often, however, these resources fail, and the hive is threatened with famine. On these occasions, the distressed bees often betake themselves to

Mutual Depredations.

plunder. Spies are sent out to examine the neighbouring hives; allured by the smell of honey, they examine the appearance and strength of its possessors; and, selecting the weakest hive as the object of attack, they begin a furious onset, which costs great numbers their lives. If the invaders should fail in their attempt to force the entrance, they retreat, and are not pursued by those whom they have assailed; but if they succeed in making good the assault, the war continues to rage in the interior of the hive, till one party is utterly exterminated; reinforcements are sent for by the invading army, and the bees from the neighbouring hives often join the assailants and share in the plunder. In a short time the whole of the enemy's magazines are completely emptied. If on the other hand, the invaders should be defeated, the successful party is by no means safe from the attacks of the bees from other hives, if any of them should chance to have mingled in the fray, and especially if they have once penetrated as far as the magazines, for in that case they are sure to return, accompanied with a large reinforcement, and the unfortunate hive that has been once attacked, ultimately falls a sacrifice to these repeated invasions.

The close of autumn puts a period to their labours abroad. They then live on the provisions they have amassed, till the cold of winter reduces them to a torpid state; from which they awake on the return of vernal warmth, and renew the same circle of labours. Sometimes the strong light reflected from the snow during a clear sunshine, deceives them with the appearance of warmth, and some bees are tempted to issue forth in order to collect provisions. All who thus venture out perish by the cold in a few minutes.

Duration of Life.

Bees seldom die a natural death. They are at all times exposed to a variety of accidents, which thin their numbers; so that the average duration of their lives does not exceed one year. We may conclude

that the whole generation is renewed in that space of time, from the results of experiments which have been tried of marking all the individuals of a hive in the spring, when it was found that none were in existence the next season. They are the natural prey of a number of quadrupeds, birds and insects; many are overtaken by stormy weather, or fly to too great a distance, and never find their way back again to the hive; others are benumbed by cold; and numbers perish in battle with others of their own species, or lose their lives by being unable to withdraw the stings which they have employed against their enemies. The fecundity of the queen-bee is, however, adequate not only to repair these losses, but to multiply the population in a very high progression. It is computed that in France a single queen will lay from 30 to 60,000 eggs; this however varies according to the climate; for in Carolina and the West Indies, they are known to produce at least three times this number. A single intercourse with the male is sufficient for the fecundation of all the eggs which the queen lays for at least two years, as has been proved by Huber; but its influence probably extends to all the eggs which the queen may lay during the rest of her life. The same queen has been observed to conduct swarms for two successive years; but the natural period of their lives is not known with any certainty. The ancients supposed it to be seven years, but Féburier suspects, that, like the males, they are destroyed by the labourers, when they have fulfilled their destination; for he was witness to an attack made by six labourers on a queen, whom he rescued with difficulty. Mr Hunter observes, that, judging from analogy, a bee's natural life is limited to a certain number of seasons; for he conceives that no individual insect of any species lives one month longer than the others of the same species. In the bee, one might suppose the period of life to be equal to the time that a hive can last; but this is not a necessary consequence, since they keep up a succession of generations. The comb of the hive may be said to be the furniture and storehouse of the bees, which by use must wear out; but, independently of this, it will, in time, become unfit for use, by the accumulation of cocoons, together with the excrements of the maggots, which are never removed. The former, indeed, lines the whole cell, top, sides and bottom; and may be distinguished from the cocoons of former maggots, that have been hatched in the same cell, by a portion of dried excrement, which is interposed between them, at the bottom of the cell. Mr Hunter has counted above twenty different livings in one cell, and found the cell about one quarter, or one-third filled up. A piece of comb so circumstanced, when boiled for the wax, will keep its form, and the small quantity of wax is squeezed out at different parts, as if squeezed out of a sponge, and runs together in the crevices; while a piece of comb that never has been bred in, even of the same hive, melts almost wholly down. Hence, the combs can only last a certain number of years. However, to make them last longer, the bees often add a little to the mouth of the cell, which is seldom done with wax alone, but with some sort of mixture; and they sometimes

Bee.

Fecundity of the Queen-Bee.

Durability of the Combs.

Bee. cover the silk lining of the last chrysalis; but all this, observes Mr Hunter, makes such cells clumsy, in comparison to the original ones.

We have thus given an account of the principal facts in the history of bees, as far as they relate to the usual or natural condition of these insects. We shall conclude with the relation of several curious phenomena, which they exhibit under particular and unusual circumstances, in which accident, or the designs of the experimenter, may have placed them.

What happens when they lose their Queen.

The loss of the queen is an event which has the most marked influence on their conduct. Although the queen is constantly an object of attention and of strong affection to the whole community, they are not immediately sensible of her absence when she is removed from the hive. The ordinary labours are continued without interruption, and it is not till a whole hour has elapsed, that symptoms of uneasiness are manifested, and it is even then only partially displayed. The inquietude begins in one part of the hive, the workers become restless, abandon the young which they were feeding, run to and fro, and, by striking each other with their antennæ, communicate the alarming intelligence very quickly to their companions. The ferment soon extends to the whole community; the bees rush precipitately out of the hive, and seek for their lost queen in every direction. This state of confusion continues for two or three, and sometimes for five hours, but never longer. Tranquillity is again re-established; they return to their labours; and selecting one of the larvæ that is not more than three days old, they break down two of the contiguous cells, sacrificing the larvæ contained in them, and proceed to build up one royal cell from their ruins. They then supply the worm with the food necessary to promote its quick growth; and, leaving untouched the rhomboidal bottom, they raise around it a cylindrical enclosure. In three days, the larva has grown to such a size as to require an extension of its lodging, and must inhabit a cell nearly of a pyramidal figure, and hanging perpendicularly. A new pyramidal tube is therefore constructed with the wax of the surrounding cells, which is soldered at right angles to the first, and the bees, working downwards, gradually contract its diameter from the base, which is very wide, to the point. In proportion as the worm grows, the bees labour in extending the cell, and bring food, which they place before its mouth, and round its body, forming a kind of coiled zone around it. The worm, which can move only in a spiral direction, turns incessantly to take its food before its head; it insensibly descends, and at length arrives at the orifice of the cell. It then transforms itself into a pupa, is enclosed with a covering of wax, as before described, and, in the space of ten days, the original loss is thus repaired by the birth of a new queen. Schirach found, that if a number of bees be confined with even a single larva, which, in the natural course would have become a working bee, they immediately set about giving it the royal education above related, and thus raise it to the dignity of queen.

While the hive remains without a queen, swarming can never take place, however crowded the hive may be. The young queens are suffered to come

out of their cells without impediment, and, after a number of deadly combats, the empire remains with the survivor. Huber has made the singular observation, that two queens, however inveterate may be their mutual hostility, never actually both destroy each other; and that when, in the course of their contest, they are placed in such a relative position as that each has it in her power to strike a mortal blow on the other with its sting, they suddenly separate, and fly from each other with every appearance of being panic-struck. The final cause of the instinct that prompts this conduct is sufficiently obvious, as, without it, the hive would be altogether deprived of a queen.

Bee.

The bees recognise the individual person of their own queen. If another be palmed upon them, they seize and surround her, so that she is either suffocated, or perishes with hunger; for it is very remarkable that the workers are never seen to attack a queen-bee with their stings. If, however, more than eighteen hours have elapsed before the stranger queen be introduced, she has some chance of escape. The bees do, indeed, at first seize and confine her, but less rigidly; and they soon begin to disperse, and at length leave her to reign over a hive, in which she was at first treated as a prisoner. If twenty-four hours have elapsed, the stranger will be well received from the first, and at once admitted to the sovereignty of the hive. If a supernumerary queen be introduced into the hive, she is laid hold of by the bees, and presented to the reigning queen, while a ring is formed by the bees, who continue to be spectators, and even promoters of the combat, in which one or other of the queens is destined to perish. Schirach and Reims had imagined that, in these circumstances, the stranger met her death from the hands of the working bees, but this mistake has been rectified by Huber, who gives the account above stated.

If the impregnation of the queen be delayed beyond the twenty-first day of her life, she begins soon after to lay the eggs of drones, and produces no other kind of eggs during the remainder of her life. This very curious and unexpected fact was discovered by Huber, and has been satisfactorily established by his very numerous and varied experiments, although its explanation is perhaps attended with insuperable difficulties. The body of a queen, whose impregnation has thus been retarded, is shorter than common, the extremities remain slender, while the two first rings of the abdomen, or those next the thorax, are uncommonly swollen. On dissecting the double ovary, both branches were found to be equally expanded and equally sound; but the eggs were apparently not placed so closely together as in common queens. It was not correctly ascertained, whether the queens, whose impregnation was retarded, laid a number of drone eggs corresponding to the whole number of eggs, both of workers and drones, which they ought to have deposited; but it is certain that they laid a greater number of drone eggs than they ought naturally to have done. On these occasions, the instinct of the queen-bee appears to suffer, for she then lays her eggs indiscriminately in large and in small cells; those laid in large cells producing large drones; those in small cells small

Retarded fecundation.

Bee.

drones; and she has been known to lay the eggs of drones even in royal cells, some of which are always constructed when the queen begins to lay male eggs. It is curious that the workers were, on these last occasions, deceived, and treated the embryo drones as if they had been truly of the royal brood.

Prolific Working Bees.

One of the most remarkable facts concerning the generation of bees, is the existence occasionally of prolific workers, the discovery of which we owe to Reim. Although it was doubted by Bonnet, its reality has been fully confirmed by the researches of Huber; and it explains what was before unaccountable, the production of eggs in hives absolutely destitute of a queen. It is also remarkable, that the eggs thus produced are always those of drones. The origin of these supplementary queens is accounted for, from their having passed the vermicular state in cells contiguous to the royal ones, and from their having, at an early period, devoured some portion of the stimulating jelly, which was destined for the nourishment of the royal brood; and from their ovaria thus receiving a partial development, which renders them susceptible of being impregnated. It is curious that these imperfect queens are still objects of jealousy and animosity to the queen-bee. How they become impregnated has not been ascertained; but the fact of their being productive was a strong confirmation of the truth of Schirach's theory concerning the sexes of bees. Needham, to whom the fact was known, had eluded the force of the argument, by pretending that these bees did not belong to the working class, but were real queens of an unusually small size. The supposed absence of ovaria in the working-bee was still, indeed, a difficulty which tended to throw some degree of doubt on the correctness of Schirach's doctrine. No person, as Bonnet repeatedly alleges, could suppose that these organs, however minute they might be, had escaped the penetration of Swammerdam, who was unrivalled in his anatomical skill in all that related to insects, and who had bestowed great labour in the examination of the structure of the bee. What had eluded his scalpel and microscope, was reserved for the still finer hand, and more dexterous dissection of a lady. Miss Jurine, the daughter of the celebrated naturalist of Geneva, has discovered, by adopting a particular method of preparing the object to be viewed, the rudiments of ovaria in the common working-bee; she examined a great number, and never failed to find them. Cuvier, in his *Leçons d'Anatomie Comparée*, mentions a suspicion that he had seen some very small oviducts in the working-bees, a suspicion which we now find to be completely verified.

Effects of Mutilations.

We have next to relate the event of experiments of a more cruel kind, but which illustrate several points in the physiology of these insects. The amputation of the four wings of the queen did not interfere with her laying of the eggs, and the workers did not show her the less attention on account of her being thus mutilated. Of course, if the operation be performed before she is impregnated, she remains barren, since it is necessary for the sexual congress that she should fly out of the hive. The amputation of a single antenna appeared to be productive of no bad consequence of any kind; but the removal of

Bee.

both the antennæ was followed with singular effects. The queen who had suffered this operation ran about in apparent disorder, dropping her eggs at random, and was incapable of directing her trunk with precision to the food that was offered her. At times she appeared desirous of escaping from the hive, and when this was prevented, she returned in a state of delirium, was indifferent to the carcases of the workers, and received another similarly mutilated queen, that was presented to her, without the least symptom of dislike. The workers, on the other hand, received the stranger queen with great respect, although the first still remained in the hive. A third queen, not mutilated, was next introduced; she was very ill received, and immediately detained and kept close prisoner. When the queen deprived of her antennæ was allowed to quit the hive, she was followed by none of the workers, and was abandoned to her fate.

Bees naturally build from above downwards, but Variations may, by a particular artifice, devised by Huber, be in their induced to reverse this process. For this purpose, a Mode of Building. glass hive, with slender laths fixed at the bottom of it, must be provided, and the bees confined in it. They are unable to fasten themselves to the smooth surfaces, and, therefore, establish the foundations of the combs on the wood, and are forced to proceed in a direction opposite to the usual one; in this way Huber was enabled to observe their proceedings. But the readiest mode of inducing them to build in any particular direction, is to supply them with portions of ready-made combs, which should be fixed with wires in the proper position; and they will always continue to complete them upon the model presented to them. The hive which Huber recommends is constructed on this principle, consisting of upright frames of a square form, fitted to each other, and of such a size as just to contain each of them a single comb; by separating these, every part of the hive can be laid open and examined with the utmost ease. Féburier has improved upon this construction by changing the shape of the frames from a square to a trapezium, having an acute angle at the summit, a form which allows the moisture that collects at the top to run down the sides more easily than it would do from a flat roof. In this way, any portion of the honey or wax may be removed at pleasure, without hurting or incommoding any one of the bees; and artificial swarms may, at the proper season, be readily procured, by dividing the hive into two portions, and adapting empty frames to each portion.

The wasp and the hornet have long been known Enemies of Bees. as the determined enemies of the bee, committing great ravages among these weaker insects; they attack them individually, but oftener commit their aggressions in large armies, on which occasions numbers perish on both sides. In some parts of America, wasps have multiplied to so great a degree, as to render it impossible to rear bees. Among quadrupeds, the ant-eater occasionally devours them. The bear and the badger overturn the hives, and plunder their contents. Rats and mice are very formidable enemies, as they invade them at all seasons, and especially during their torpid state, when they are incapable of revenging the aggression. The woodpecker may succeed in breaking through

Bee
||
Beggar.

the hive, and then speedily destroys all its inhabitants; the swallow, the sparrow, the titmouse, the cuckoo, and the *Merops apiaster*, or bee-eater, and poultry of every kind, prey upon them separately. According to Bosc, they are also food for the shrikes, and for the *Falco apivorus*. Lizards watch for them, and seize them as they alight near the hive. Toads occasionally devour them. They are in some danger from the larger kinds of spiders, and of *Libellulae*, as also from the *Philanthus apivorus* of Fabricius. But the most insidious and destructive enemy of these insects is the moth; various species of which, particularly the *Phalena mellolena*, insinuate themselves into the hive, and deposit their eggs unperceived between the cells, in such numbers, that the hive is soon overrun with the larvæ, where they are hatched, and the bees are forced to abandon the hive. A new enemy of the same tribe has been lately discovered by Huber, in the *Sphinx atropos*, well known by the name of death's head. Towards the end of autumn, when the bees have filled their magazines, a loud hum is sometimes heard near their habitation, and a multitude of bees come out during the night, and fly about in the utmost confusion. The tumult continues for several hours, and the next morning a number of dead bees are strewed before the hive. On examining the hive, it is found to have been robbed of all its honey, and the bees do not return to it. These effects result from the incursions of the sphinx, which watches its opportuni-

ty to introduce itself into the hive during the night, when the bees are deprived of the advantages of vision, which the sphinx enjoys in greater perfection at this period. By rendering the door-way extremely narrow, so as only to admit a single bee at a time, this accident may be prevented; and it is curious that the bees themselves frequently anticipate this danger, and provide against it by employing, of their own accord, the very same mode of defence. They construct a thick wall which barricades the entrance, and resembles a regular fortification, with bastions, casemates, and massive gateways. They often, indeed, have recourse to a similar contrivance for protection against the pillaging-bees, enabling them to repel the assault with greater effect. At other times when the danger is less pressing, the inconveniences of so narrow a gateway being strongly felt, they enlarge it by removing the fortification they had built, and do not again construct it unless the appearance of the enemy in the ensuing season should inspire them with fresh alarms. If, on the other hand, the precaution of narrowing the gateway should already have been taken by the cultivator, the bees, feeling themselves secure, spare themselves the unnecessary labour of erecting these walls. This single trait in their history is a sufficient refutation of those theories which ascribe all their actions to the operation of a blind indiscriminating instinct, and would exclude every species of foresight and reflection. (w.)

Bee
||
Beggar.

B E G G A R.

Definition. THE word literally means, *one who begs*. In a more restricted sense, it means one who begs the means of subsistence. Even this definition, however, is too extensive for the idea to which, in this article, we mean to confine it. The class, in fact, of the persons to whom the term *beggar*, in the most restricted sense, applies, cannot easily be separated by an exact line of distinction from the kindred tribes. You cannot define the beggar as one who asks the means of subsistence, or money to purchase it, from passengers in the streets and highways; because there are people who beg from house to house. If you include those who beg from house to house, even that will not suffice, because there are persons who beg by letter, and have various means, beside language, of bringing to the knowledge of others the tokens of real or fictitious distress. And, if you make a definition extensive enough to embrace all these classes, you will make it include persons whom no one regards as standing in the rank of beggars; every person, almost, who, from any cause, is brought to require the assistance of others. It is not useless to contemplate how these classes run into one another; because it teaches the necessity of delicate and cautious proceedings, when we take measures of cure; especially if *force* enters at all into their composition.

Different
Classes of
Beggars.

1. Of the class of persons to whom, in the common use of language, the term Beggar is with pro-

priety assigned, there is one distinction which is obviously and commonly made; that is, into those who beg from necessity, and those who beg from choice. In each of these divisions, there is great variety. For a description of the field of mendicity we derive helps from the *Report of a Committee of the House of Commons*, appointed in the year 1815, to inquire into the state of mendicity in the metropolis. The inquiry is very imperfect; the interrogation of the witnesses superficial and unskilful; the information which they give not followed up, by exploring other and better sources, which they indicate; but, as people had been left to casual observation, to fancy, and conjecture before, the facts and conjectures which that Report lays before us are still the best information we possess.

Nothing more strongly indicates the deficiency of our knowledge upon this subject, than the different opinions which the Committee received on the proportion between those who beg from necessity, and those who beg from choice. The persons examined were those of whom the Committee made choice, as having possessed peculiar opportunities of knowledge; and this was a point to which their inquiries were peculiarly directed. Yet one part of the witnesses strongly asserted, that a proportion as large as one half were beggars from necessity; another part of them asserted that all beggars, with hardly any exception, prosecuted the occupation from choice.

Beggars.

Mr Martin, the conductor of an inquiry into the state of mendicity in the metropolis, under instructions from his Majesty's Principal Secretary of State for the Home Department, which inquiry extended to about 4500 cases, stated, as "the general result of his information, that beggary is, in very many cases, perhaps in about half the cases of those who beg, the effect rather of real distress, than of any voluntary desire to impose. So far from having found, amongst those who have attended at the office, any reason to think that the whole was a matter of imposition, I have (says he) found cases of the most acute suffering, which have long been concealed, of some of the beggars, who belonged to parishes in the metropolis, who have not made their cases properly known to the parish-officers, and who have ventured to slip out of their parishes, not so much because they wished to impose, as because they were driven by distress to beg." Mr Martin grounded this conclusion also upon the general fact, that the number of women was much greater than that of men, and that of married women greater than that of single. "Men," he remarks, "are stronger than women, have more resources, and are better able to provide for themselves; and single women are more eligible for service than married, and usually have only themselves to maintain."

The Rev. Henry Budd, who had been fourteen years Chaplain to Bridewell Hospital, to which the greater number of the persons taken up for begging in the streets of London are committed, was asked, "Have you ever known a worthy person begging in the streets?"—"Yes; I have known many that I should call worthy; and, I think I could mention some who have come up from the country distressed for want of work. They think London is paved with gold, or presents opportunities the country does not; and they find themselves here without friends. I have met with many whom I considered very worthy."

Of these two witnesses, the personal experience in the case was equal, or probably superior to that of all the rest taken together.

From other witnesses, however, of whom the experience was also great, the committee received affirmations of an opposite import. Mr John Cooper, a visitor of the *Spitalfields Benevolent Society*, was asked, "From the observations you have made upon the state of poor families, do you think any worthy families have recourse to begging in the streets?"—*Ans.* "I have no idea at all, from what has come under my own observations, that, in any individual case, persons, that were worthy objects, however distressed they were, have had recourse to street-begging."

Mr John Doughtry, a gentleman much in the habit of visiting the habitations of the needy, was asked, "In your opinion, do many worthy, honest, industrious persons have recourse to begging, or does this class of society consist chiefly of the idle and profligate?"—*Ans.* "The instances in which worthy, honest, industrious persons have recourse to begging are extremely rare. They will, in general, rather starve than beg. A person of veracity, who sometime ago visited 1500 poor families in the

Beggars.

neighbourhood of Spitalfields, affirms, that, out of full 300 cases of *abject poverty and destitution*, and at least 100 of *LITERAL WANT AND STARVATION*, not a dozen had been found to have recourse to begging. Many of the most wretched of the above cases had been, not long before, able to support themselves in some comfort, but want of employ had completely ruined them. They were, at that moment, pressed by landlord, baker, and tax-gatherer; had pawned and sold every thing that could be turned into money; were absolutely without a morsel of food for themselves or family; but still had not recourse to begging. As a general fact, the decent poor will struggle to the uttermost, and even *perish*, rather than turn beggars."

This is heroism, in comparison with which, that of the Herculeses and the Hectors, ancient and modern, sinks into nothing! What an admirable foundation of virtue must be laid, in these minds, which even thus endure the horrors of death, approaching with all the torments of hunger and cold, rather than seek to relieve themselves by courses reputed disgraceful! And how unworthily is this class of persons traduced, by those who represent them as capable of being restrained by nothing but a dungeon or a bayonet; and who, by their ignorance of human nature, so cruelly prolong the needless miseries under which it labours!

According to the experiment mentioned by Mr Doughtry, and it is upon a large scale, and a part of the population (the circumstances of the people in Spitalfields are not favourable to virtue) which may be reckoned below rather than above the common standard, out of 400 individuals, of the lowest order, 388 will consent to perish by hunger, rather than beg. In confirmation of this testimony, an extraordinary fact has come to our knowledge. We have been informed by a gentleman, whose knowledge of the circumstances and behaviour of the journeymen in the metropolis may be regarded as in a very unusual, or rather an unexampled degree, minute and correct, that, of this important-portion of the labouring population, no one ever begs; that such a thing as a journeyman-tradesman, or any of his family, begging, is almost unknown; and may, with certainty, be pronounced as one of the rarest of contingent events. When it is considered to what an extraordinary degree most of the employments by which these men earn the means of subsistence are liable to fluctuation; that thousands of them are for months together deprived of work, as was the case with thousands, for example, of the carpenters and bricklayers during the severe winter of 1815; that of those the whole must be reduced to the most cruel privations, and a great proportion actually starve unpitied, unheard of, and unknown; the resolution by which they abstain from begging, should be regarded as one of the most remarkable phenomena in the history of the human mind.

It may still be possible to reconcile these undoubted facts with the testimonies of Mr Martin and Mr Budd. It appears that a great proportion of the beggars to whom they allude are women, and women with families; whose spirits, where they are left to themselves, are less able to support them, and to make

Beggar. the dread of disgrace an overmatch for the pains of hunger and the terrors of death. It appears, also, that a large proportion of them are the wives of soldiers, in the company of whom the sense of disgrace is apt to lose its pungency. People from the country, simple, and without resources, add a portion to the number of those whose mendicinity cannot be regarded as the effect of vice. And it cannot, surely, be a source of wonder, that, out of so large a population, so great a portion of whom are liable to the extremity of want, there should be a few with whom the dread of disgrace should not be so powerful a motive as the love of food, and of life.

Number of Beggars.

2. Of the number of beggars in the metropolis (and no attempt has been made to discover it in the rest of the country), the labours of the Committee have ascertained hardly any thing. At the time of the first inquiry, which was made by Mr Martin, 2000 cases presented themselves. This, by a vague estimate, he supposed might be about one-third of the whole; and allowing at the rate of a child and a half to each principal, he conjectured that the whole number might be about 15,000. If this be supposed a tolerable approximation, with regard to the metropolis, a comparison of the population of the metropolis with that of the whole country, will give an approximation to the number of beggars in the kingdom.

3. With regard to the number of beggars, an important fact appears to be ascertained; that it is gradually diminishing. Mr Martin said, "I do think that the number of beggars has something decreased since the first inquiry, nine years ago; and I am very much confirmed in that opinion, by what persons have told me, that they have not seen so many as they did. I really think there are not so many by one-fourth." Sir N. Conant, of the Police-office in Bow-street, said, "I think the number of beggars was greater thirty years ago than now. I have acted as a magistrate for more than thirty years.—Do you mean greater in proportion to the population?—Greater in fact. I am sure, on my own recollection and observation, that mendicinity is a less nuisance now than it was thirty years ago."

Sir Daniel Williams, a magistrate attending the Police-office in Whitechapel, was asked, respecting the beggars in that district, "Do you think the number has increased within any given period?"—*Ans.* "I think, within the last two years, they have rather diminished." Mr John Stafford, chief clerk of the office in Bow-street, said, "It strikes me, from the knowledge I have had, having been chief clerk of the Police-office in Bow-street ever since the year 1808, that there are not the same number of beggars about the streets that there used to be; I think the number is considerably decreased." This corresponds so fully with what strongly meets the observation of every attentive man, and has been amply given in evidence before the Committees of the House of Commons, on the state of education, and the police of the metropolis, during the last session of Parliament, respecting the great improvement in the morals and in the manners of the lower or-

VOL. III. PART I.

ders, that it may be regarded as a fact of which no reasonable doubt can be entertained.

Beggar.

4. This is the little which appears to be known with regard to the proportion between the beggars from choice, and the beggars from necessity, and with regard to the number of the whole. We shall next speak of the arts by which it is understood that the trade of beggars is carried on. This appears to be the grand subject of curiosity. There is a mystery about this, and a fancied ingenuity, which those who wish for the marvellous are very much stimulated to explore and to magnify. The fact, however, is, that the contrivances, upon the whole, are few, and almost all of them obvious, and coarse. They are expedients for exhibiting as much as possible of the appearances of distress. Of these, rags and nastiness are one portion, which it surely requires but little ingenuity to display. The different kinds of bodily infirmity, chiefly those which incapacitate for labour, are the remaining portion. On this subject the most authentic details which have been collected, are those contained in the *Report of the Committee on Mendicinity*. We shall select from the evidence, as far as it goes, the description of the principal arts; and the intelligent reader will perceive, that, with regard to invention, they are near the bottom of the scale.

Deceptions practised by Beggars.

The Reverend William Gurney said, "I am rector of St Clement Danes, and minister of the Free Chapel in West Street, St Giles's. In the course of my ministry there, I have had a great deal of occasion to visit persons in very great distress. I have ascertained, that there are four different ways of begging. Some are by letters, which are sent by post; and some are what we call knocker beggars, who go from house to house, knocking at every door. If they get a knowledge of any respectable person in the street, they pretend they have received money at his house, to make a sum to pay rent, or the postage of a letter from a son who has been six or seven years at sea, and from whom they expect a remittance; or for other purposes. On these occasions they have generally some written statement in their hands. Some beggars are stationary. They come to their stand at a certain hour, where they remain all day, or after so many hours repair to another. Of these beggars, those who are blind, or maimed, or have children, succeed the best. There are others, women and children, who are moveable beggars, following not the street but the people. For instance, at the time of the play, they are always very near the theatres; and if they see a young gentleman and a young lady walking together in deep conversation, they will pester them, and run before them till they give them something to get rid of them. Those people, at other times of the day, if it is a Sunday, for instance, will be found near chapels where there are large congregations; they know as well where the large congregations are as possible. There are others who are continually begging from house to house; they go through a great number of streets in the day, occasionally taking a ballad, or a bunch of matches, and pretend to be picking up bones in the street, and early in the morning kneeling down to areas, tormenting the

g g

Beggars

cook when she is busy in the kitchen, until they get some broken victuals, as they call it, but they actually sell this victuals; that I have found out. In St Giles's there are some eating houses for the very poorest mendicants, where they go and sell this victuals they get from different houses."

This is a correct description of the most common cases of begging. There is one case, by no means uncommon, which we do not perceive described by any of the witnesses; that, when three or four men, being or appearing to be lame or maimed, and most commonly in the guise of sailors, go out in a body, singing with great loudness, and almost barricading with their bodies the streets through which they move, in such a manner, that nobody can pass without a vehement onset, while the timid or sensitive hardly dare to resist. Of course, this takes place only in these streets in which there is least danger of their being taken up.

The following is a description given by the Reverend W. Gurney, of some other classes of beggars. He had mentioned a set of applications frequently made to him, by persons who pretended that prize-money, or benefits of some other sort were due to them, of which, however, being deprived by want of knowing the steps to be taken, they entrusted a letter to somebody who would instruct them; "but their object was to get a letter with my name to it, with which probably in a short time they could get L. 20. If I have written to any body in the office of the Treasurer of the Navy, whom I knew, for instruction or counsel how they ought to act, recommending the bearer to this person for any information he could give upon such points; if I only said, I beg leave to recommend the bearer to your notice, they would paste this upon another sheet of paper, cutting off the bottom part (and one person was detected in doing this), and then they would take the name at the bottom, and so paste it together, making a kind of a recommendation of this person: knowing who I was acquainted with, some other clergyman, perhaps setting me down as giving them 10s.; that clergyman is induced to give them 10s. also, and to send them to some benevolent person in his congregation: and so they go on till they have got L. 20: and that has frequently been done, I do not mean always by imposition. But, in many cases, where persons have been in distress, through providential circumstances, I have written to another clergyman, saying, such a woman was distressed, and had so many children, and that her husband was out of work, and that this I knew to be the fact, for I had inquired. I have given half a guinea, and have given the names of others; and by this means sufficient relief has been procured without coming to the parish at all. But the impositions on the subject of recommendations are very great; I have had letters from all parts of the country, inquiring whether I gave a general recommendation to such a person; and they have said, we saw a letter purporting to be in your handwriting; we were pretty confident it was not written by you, but it was a very good imitation. One man in Staffordshire, where I had lately been, got a great deal of money upon such a letter. I conceive

Beggars

the beggars in the streets are more numerous at one time of the year than another; and it would be supposed the time of the year when they were most numerous, would be in the early part of the winter; but that is not the case, for now they are as thick as at any time of the year. I have been endeavouring for a long time to ascertain the reason of this; and the first obvious reason for the influx of beggars into the metropolis, at this season of the year, is, with respect to one class of beggars, those who do it by letters or recommendations, and not going from house to house, that they take advantage while Parliament is still sitting, or particular persons being in town; they perhaps are pretty stationary in London all the year; but they are more anxious at this time, and therefore more heard of, because people are going out of town, and therefore they are taking time by the forelock, and work double tides; that is the reason I very frequently have letters sent by friends of mine in affluence, Mr Wilberforce and others, requesting me to inquire into particular cases, and if I found them to be as represented, to give them so and so. I have generally been troubled more at this season of the year than at any other. As to those who knock at the door to beg, the reason of their being so numerous at this time of the year, I apprehend, is, that many come out of the country with a view to take the early hay-time about the metropolis, but they bring always a large suit with them. If a man comes to mow in the neighbourhood of the metropolis, they mow their way back again, the harvest beginning sooner near the metropolis; they bring with them a wife and six or seven children. I have seen hundreds coming up through Stanmore, when I resided there. They generally come too soon, and the streets are filled with these poor people: One says, if I could but get money to buy a fork I could get work; and another, if I could get money to buy a rake, I could get employment. I have had half a dozen with me since Saturday, stating that they came up to get a job of work, but the market is overstocked: there are so many Irish here. The consequence of these people coming is, their children are immediately set to begging in the streets, and with the dust upon them, having travelled a great way, and frequently in real want, they move the compassion of people very much; they are frequently sitting with papers stuck in their hats. In the course of six or eight weeks great numbers of those will disappear; the husbands will get to mowing, their wives will get a hay-fork, and the children will get to weeding in the gardens: Then they get a dreadful habit, by coming to the metropolis, a habit of idleness and drinking; and those children are annually instructed in idleness and drinking, and of course lying; idleness is sure to bring on lying and theft. I dare say there are very few of these mendicant children who are not trained up to pilfer as well as to beg; they come principally, I believe, from the manufacturing counties. On a journey from Birmingham to London, two years ago, I passed not less than two hundred with their wives and children, who were begging as I passed."

The following statement is inserted in the Re-

Beggar. port of the Committee, under the title of "Information communicated by three members of a Society instituted for Benevolent Purposes:"

"In Nicholas-court, Rosemary-lane, there are about twenty beggars, male and female, of the very worst description, great impostors, drunkards, blasphemers, &c.: their rendezvous the City of Carlisle, Rosemary-lane.

"In Mill-yard, Church-lane, about ten female beggars.

"In White Horse-court and Blue Anchor-yard, about fourteen beggars.

"In Dottridge-street, New-street, and St Catherine's-lane, about thirty female beggars.

"In Angel-Gardens and Blue Gate Fields, about twelve beggars, four of them blacks.

"In Chapel-street, Commercial-road, six beggars.

"In Goodman's-yard, Minories, six beggars affecting blindness.

"In the neighbourhood of Shoreditch and Bethnal Green, about thirty-five families may be computed at one hundred and fifty members, who subsist by begging and plunder. There are about thirty Greenwich Pensioners, who hire instruments of music and go out in parties.

"If each beggar does not procure at least 6s. *per* day, they are considered very bad at their business.

"In visiting George-yard, leading from High-street, Whitechapel, into Wentworth-street, we found there were from thirty to forty houses apparently full of people; and being desirous of knowing the situation they were in, we gained access to several of them where we had formerly visited distressing cases; and from the information we collected, we conceive that in these houses there are no less than two thousand people; the whole place, indeed, presents such a scene of human misery and dissipation as can hardly be conceived. We learned from those we had access to, that one half of these inhabitants subsist almost entirely by prostitution and beggary; the other half are chiefly Irish labouring people.

"In Wentworth-street (adjoining the above yard) there are a great many houses occupied by inhabitants similar to those in George-yard. One of these (a private house, No. 53) we visited, and were not a little surprised to find that it contained one hundred beds, which are let by the night or otherwise, to beggars, and loose characters of all descriptions. In some of the lanes leading from this street, there are other houses of the same kind."

Mr Sampson Stevenson, who had been Overseer of the parish of St Giles's the preceding year, and by that circumstance forced into an acquaintance with the practices of its begging inhabitants, said,—"There is a man whose real name I do not know, but he goes by the name of Graane Manoo. He is a man who, I believe, is scarcely out of jail three months in the year; for he is so abusive and vile a character, he is very frequently in jail for his abuse and mendicity. He is young enough to have gone to sea, but I believe he has been ruptured, consequently they will not take him. I have seen him scratch his legs about the ancles, to make them bleed; and he never goes

Beggar. out with shoes. That is the man that collects the greatest quantity of shoes and other habiliments; for he goes literally so naked, that it is almost disgusting for any person to see him in that situation. Another man I have known upon the town these fifteen or twenty years; he is a young man as nimble as any man can be. I have seen him fencing with the other people, and jumping about as you would see a man that was practised in the pugilistic art. He goes generally without a hat, with a waistcoat with his arms thrust through, and his arms bare, with a canvass bag at his back; he begins generally by singing some sort of a song, for he has the voice of a decent ballad-singer. He takes primroses or something in his hand, and generally goes limping or crawling in such a way, that any person would suppose he could not step one foot before another. I have also seen him, if a Bow-street officer or beadle came in sight, walk off the ground as quickly as most people. There is a man who has had a very genteel education, and has been in the medical line, an Irishman; that man writes a most beautiful hand, and he principally gets his livelihood by writing petitions for those kind of people, of various descriptions; whether truth or falsehood I know not, but I have seen him writing them, for which he gets from sixpence to a shilling.

"Do you know whether they change their beats?— I have seen them come out from twenty to thirty out of the bottom of a street, formerly called Dyot Street, now called George Street. They branch off, five or six together, one one way, another another. Invariably, before they get to any great distance, they go into a liquor-shop, and if one amongst them has saved (and it is rare but one of them saves some of the wreck of his fortune over night), he sets them off with a pint of gin, or half a pint of gin amongst them, before they set out. Then they trust to the day for raising the contributions necessary for their subsistence in the evening. They have all their divisions. The town is quartered into sections and divisions, and they go one part one way, another part another. In regard to the mendicity of people begging with children, I can give a little information upon that. There is one person, of an acute nature, who is practised in the art of begging, will collect three, four, or five children from different parents of the lower class of people, and will give those parents 6d. or even more *per* day, for those children to go begging with. They go in those kind of gangs, and make a very great noise, setting the children sometimes crying in order to extort charity from the people. I had an opportunity of seeing a number of those cases, being a parish officer. They will sometimes have the audacity to come to the Board for relief, which we have four days a-week: there is a great deal of money given in St Giles's. They will, if necessary, swear they are all their own children, and being, in general, of Irish parents (wherever the tree falls it must lie), consequently they get some relief till we can make proper inquiry; but, in a very short time, they are found out, for we generally send to the place they come from; but the landlords and landladies are so cunning, they would swear that the whole of those children belonged to them. But we have people of their own class, to whom we

Beggar. are obliged to give something to detect the impositions we are liable to, for we are often imposed upon. A great many of those cases were before me last year as a parish officer; where a woman had been in the habit of receiving 5s. a-week, and at last a woman of her own country came forward, and taxed her that three of the children were not her own. We never saw them again, but they went into other parishes, such as Mary-le-bone, St Andrew's, and other parishes, and sought relief there; they know we cannot remove them. We have had other persons whose families are their own, and when they have a habit of begging, and get a good deal of money by that trade, they will not go to work. But we have complaints from a variety of persons round Bedford and Bloomsbury Square, of those persons being nuisances. And when the parties have come to the Board, we have offered them the house to come in with wife and children:—"No; I expect my husband home very soon, and I will not come into the house." In those cases we get rid of them, but we invariably offer them the house. When they will not take it, then we stop the relief, for I think the house is the best thing for a family of children, and a distressed family of that description."

Mr William Dorrel, inspector of the pavement of St Giles's and St George, Bloomsbury, said,—“One evening I was coming down Tottenham-court Road; a man and a woman, both beggars, were quarrelling. The man swore at the woman very much, and told her to go down to such a place, and he would follow her. I said to myself, I will see this out. She appeared to be pregnant, and very near her time. I went down to Sheen's, I think he sent her there. There was a quarrel, and he said, “I will do for you presently;” and he up with his foot and kicked her, and down came a pillow stuffed with straw, or something of that kind; she was very soon delivered. I have been informed of a circumstance respecting a man of the name of Butler, that went about; he had lost one of his eyes. I am told he had been to sea. He had a dog, and walked with a stick; the dog went before him; he hit the curb-stone. People supposed he was blind of both eyes; he turned his eye up in such a way that he appeared blind. When he returned to his hotel, he could see as well as I could, and he wrote letters for his brother-beggars. This man has been dead two or three months.”

The following is a curious fact, testified by Mr T. A. Finnigan, master of the Catholic Free School in St Giles's.—“About two years ago, there was an old woman who kept a night-school, not for the purpose of instructing children to spell and read, but for the sole purpose of teaching them the street language, that is, to scold; this was for females particularly. One female child, according to the woman's declaration to me, would act the part of Mother Barlow, and the other Mother Cummins; these were the fictitious names they gave. The old woman instructed the children in all the manoeuvres of scolding and slapping their hands at each other, and making use of the sort of infamous expressions they use. This led them into the most disgraceful scenes. When these children met, if one entered into the depart-

ment of the other the next day, they were prepared to defend their station, and to excite a mob.” **Beggar.**

This is nearly the whole of the information which is contained in this celebrated Report, with regard to the *arts* which are employed by the beggars of the metropolis. We shall next consider the estimate which ought to be formed of their *gettings*. On this subject also exists a great bias to exaggeration. Both the Committee, and these witnesses, with certain exceptions, appear to have been led by it. **Probable Amount of the Gains of Beggars.**

Mr Gurney had heard of one individual who boasted that he could with ease earn 5s. a-day; that he would go through sixty streets, and that it was a poor street that would not bring him a penny. Sir Nathaniel Conant, however, being asked, “Did it ever come to your knowledge, what any of the mendicants got?” made answer,—“I have heard very large sums stated, but I disbelieve many of them; I have not known of money being found about them; there are a good many very impudent fellows certainly about the streets, who are very troublesome: those who have been taken up have been seldom found with more than a shilling or two, but I believe some of them had hoarded at home. There was a woman brought before me, when I acted at Marlborough-street, who had a caddy in which there were nine or ten guineas hoarded.”

Joseph Butterworth, Esq. a member of the Committee, stated as an inference from credible information which he had received respecting their mode of spending, that their daily acquisitions would not be less than from 3s. to 5s. each. One particular girl, however, whom he examined, stated that 1s. 6d. was the common amount of what she was able to collect, though on some days she made as much as 4s. or 5s.

Mr Sampson Stevenson was asked,—“Has it fallen within your knowledge what the largest sums are that have been gained by beggars in the course of the day?—That I have been unable to ascertain, but I have heard them brag of 6s., 7s., or 8s. a-day, or more, according to their luck, as they call it; and if one gets more than the others, they divide it with the rest.”

It appears from the words themselves of the evidence on this point, that it is insufficient to prove anything. It is either the result of hearsay, which hearsay was probably the result of conjecture, not of knowledge; or it is founded on what the beggars themselves have said, when in a boasting humour; that is, when actuated with a desire to make their *gettings* appear as large as possible, and when, of course, their own declarations about the amount of them are, as evidence, of little or no value.

6. The ground on which the opinion of the great profits of begging seems chiefly to be founded, is the notion which is entertained of their expensive mode of living. It is therefore necessary, before we adduce the remarks which appear to be called for on the subject of profits, to state the evidence which has been furnished on the subject of expence.

The Reverend William Gurney was asked,—“Have you understood that the beggars' walks are considered as a sort of property?—Yes; I have

Beggar. no doubt of it; they never interfere one with another.

“ And that a blind man stationed at a particular place, drives away others who interfere?—Yes; and they have their rules and their carousings: There is a house in Kent Street, where I have seen a great fat man, who moves himself about on a wooden board. When I lived near the Kent road, I have seen eight or ten of these persons go into a miserable house in the lower part of Kent Street. I have seen tables set; one a very long table covered with a coarse cloth, but a clean one; and there was something roasting: I was afraid to go in, on account of this man, who was a very violent one; this man was among the rest; they were going to have their dinner at the fashionable hour of seven. There was a cripple among them, who used to be at St George's Chapel in St George's Fields; he used to lie there, and pretend to hold out a pamphlet; he was weak about the loins, and his legs folded under him. I really believe the stories which have been told are not exaggerated.

“ Have you any opportunity of knowing that the bread they eat is always of the best?—Yes; they would never eat any but the best wheat bread.”

This evidence proves but little. It is solely by conjecture, Mr Gurney here infers that there was any considerable expence.

Sir Daniel Williams was asked,—“ Do you know their mode of life?—There was, in a situation called Church Lane, Whitechapel, some years ago a house of resort of beggars, which was well known to all that class of people in every part of the metropolis, by the name of The Beggar's Opera: the sign of the public-house was the Weaver's Arms, but its slang name was The Beggar's Opera: At the period I am mentioning, these beggars used to resort there of an evening, after having perambulated their different circuits, and lived well; they spent a considerable portion of money, would have hot suppers dressed, and regale themselves with beer, punch, and often other liquor still more expensive.”

How unfortunate, and at the same time how strange it is, that not a single question was put to this gentleman, to ascertain whether he knew this by hearsay, or by observation. We are constrained to conclude that it was only by hearsay; because, had he seen the facts, it would have been natural to say so; and because we are never entitled to make an inference stronger than the premises on which it depends.

Mr Butterworth describes scenes of a similar sort, but has attention enough to accuracy to say, that he is only credibly informed of the things which he states. Not a question is put to him about the sources whence his information is derived; much less are any of the persons who gave it brought before the Committee, who ought not to have been contented with the hearsay, when they might have had the original evidence. Mr Butterworth did, indeed, volunteer (for he was not provoked to it by any interrogation) the description of one person. “ I know,” he said, “ a sober hackney-coachman, upon whose veracity I can depend, who has frequently conveyed beggars to their lodgings; and former-

ly, when he plied in St Giles's, has been called to the public houses which they haunt, to take them from thence, being so intoxicated they could not walk home.” If this information of the hackney-coachman was of any value, how wrong it was not to call the hackney-coachman, and get his own information from himself? According to what appears from Mr Butterworth's words, he might have conveyed a beggar from those houses, either twice or two hundred times in his life.

This is a very imperfect mode of collecting evidence.

The only person who gives anything that resembles the evidence of his own observation upon the subject is Mr Sampson Stevenson. He was asked,—“ Have you had an opportunity of making observations on the character of street beggars?—A great deal; not only before I was officer, but having been led by being officer to look into the matter, I have made great observations, because there was a house which those kind of people used, not above eight yards from my own house; complaint being made, the nuisance was done away.”

“ Have you had an opportunity of making particular inquiry into the character of individual beggars?—I have; in fact, I made inquiry, not only of the landlord, but of some of those who seemed to be of a superior class, or petition writers; that was before I was overseer. A year or two ago this house lost its licence; it not only encouraged those kind of people, but people guilty of felonies, and so on. This threw them into other quarters; and they made their residence at a public-house called The Fountain, in King-street, Seven Dials, where they assembled not only at night, but in a morning before they started upon their daily occupations, as they express it; I have seen them come in. As it is a house, the landlord of which is very respectable, and has a family, I have gone into the bar on purpose to see their manner of going on; that is very near the tap-room: They come at night, perhaps individuals, and likewise those sailors, or pretended sailors, in a body; but those who go one and two together come also: those who are sailors never take anything on their backs like knapsacks, for they only beg or extort money; but the others beg clothing, or anything they can get, and they always have a knapsack to put it in; they will come loaded with shoes and various habiliments, which, being near Monmouth-street, the place where they translate old shoes into new ones, they sell, and likewise the clothing. I have heard them say, that they have made 3s. or 4s. a-day in begging shoes, for sometimes they got shoes that really were very good ones; and their mode of exciting charity for shoes is, invariably, to go barefooted, and scarify their feet and heels with something or another to cause the blood as it were to flow. I have seen them in that situation many times; and thus they sally out to their different departments, but invariably changing their routes each day, for one is scarcely ever seen in the same direction two days together, but another takes his situation. I have seen them myself; I never saw them outside: but I have seen considerable sums of money pulled out and shared amongst them,

Beggar.**Beggar.**

Beggar. both collectively and those who go two or three together. Victuals I do not think I ever saw brought into that place, for I rather think they throw it away when they get it. Mostly shoes and clothing, and such things as those, which they sell immediately. They stop as long as the house they use is open, and get violently drunk, and quarrel with one another, and very frequently fight; after that they are not allowed to remain, if they were, the licence would be stopped; and very likely there are houses in St Giles's where they spend the other part, if they have any left.

“What is their general character?—They are people that are initiated in this mode of begging; one teaches another their modes of extorting, for I can call it nothing else but extorting: And they are of the worst of characters, characters whose blasphemy it is almost impossible to repeat; they will follow you in a street for a length of space, and if they do not receive money, they give a great torrent of abuse, even all the time you may hear them. Most of them have no lodgings. There are houses where there are forty or fifty of them, like a jail, the porter stands at the door and takes the money; for 3d. they have clean straw, or something like it; for those who pay 4d. there is something more decent; for 6d. they have a bed; they are all locked in for the night, lest they should take the property. In the morning there is a general muster below. I have asked country paupers who have come for relief, how they have been entertained, they say, Very badly: they have gone there. The servants go and examine all the places, to see that all is free from felony; and then they are let out into the street, just as you would open the door of a jail, and let out forty or fifty of them together, and at night they come again; they have no settled habitations, but those places to which they resort; but there are numbers of those houses in St Giles's.”

Most of the statements in this declaration are very loose and vague. Yet not a question is put by the Committee to ascertain how far the witness had actually seen and heard, and how far he merely conjectured. No; he is allowed to make up a compound of what he saw, and what he conjectured, just as he pleased, and to leave the ingredients without any distinction. In several things he is palpably and grossly erroneous. For example, he supposes that beggars in general throw away the victuals which they collect. It is likely that they should take the trouble of collecting any thing merely to throw it away! It is likely they should throw away that for which they might get money! Besides, the assertion is contrary to what is actually delivered in evidence to the Committee; the fact, that there are places in St Giles's where the commodity is regularly bought, and where those who have collected it go to sell it.

Nothing is more common, in cases of this sort, than to receive a violent impression from the strong cases, however few; to overlook and forget the small cases, however numerous; and from the strong cases solely to draw every inference to the whole. There are strong marks of this imperfection in the

evidence which is given in this Report. Mr Stevenson, for example, in the passage which has just been quoted, gives it, without any restriction whatsoever, as a general characteristic of the beggars of whom he speaks, to be very abusive when their applications are refused. Now, this may safely be pronounced as one of the rarest occurrences. The writer of this article may give his own evidence. He has lived above fifteen years in the metropolis: he has walked more than most people, both in the streets of London, and in the roads and fields immediately surrounding it: he never gives anything to a casual beggar: he has been accosted by thousands of beggars: he cannot at this moment recollect that, in the whole course of that experience, he ever met with one abusive word: but he has a hundred times received a “Thank you, Sir,” with a bow or a curtsy from the little boys and girls whom he has refused and repulsed; and to whom it is evident that such a lesson is taught by those on whom their conduct depends. The impostrous beggar, in fact, knows his art too well to lose his temper; and the spirit of the age, so much improved, renders a mild deportment necessary to the success even of the worst employment.

Of this evidence about the great gains of beggars, some parts are directly and strongly opposed to the rest.

Thus we are told that they eat and drink most voluptuously; we are also told that their sleeping places are wretched beyond description. But why should this be, if they were able to afford, in this respect, a higher degree of comfort? Notwithstanding what we are told about their delicate feeding, we are also told that there are eating-houses to which the beggars resort, and in which they buy the scraps of victuals, collected at doors, which the beggars who have collected beyond their own consumption there dispose of. This is no proof that they are generally able to cultivate delicacy.

So slight an exercise of reflection is sufficient to show that the gain of beggars must of necessity be wretched, that one is astonished at the proof which is exhibited of the inattention of mankind, by the number of persons who believe the contrary. According to the principle of population, which supposes a greater number of hands than can find employment, the ordinary occupations and trades may all be regarded as overstocked. The lowest is necessarily the most overstocked of all; because the hands which overflow from the rest are all driven downwards, and the lowest receives the overplus of the whole. The lowest species of occupation is, therefore, of necessity underpaid; that is to say, the wages of the labourer are not sufficient to maintain him with such a family as is necessary to keep the number of labourers, in that occupation, at its existing amount. But it must necessarily be, that the gains of beggars, upon the whole, that is, the gains of an average beggar, are below, and considerably below, the earnings of individuals in the lowest and worst paid species of labour. If it were not, it would follow, that the wretched starving people, employed in the lowest, naturally the hardest and most pain-

Beggar. ful, species of labour, of consent, will choose to receive a small sum with hard and painful labour, when they might receive a larger sum without any labour at all; it would follow that, out of a multitude, amounting to the greater part of the population, all, or all but an insignificant portion, are endowed with this degree of heroic virtue. This would be to suppose a sensibility to moral considerations which, in the circumstances of an oppressive and degrading poverty, is utterly incompatible with the laws of human nature.

We regard it, therefore, as a matter of demonstration, that the earnings of beggars, as a class, are considerably below the earnings of the worst paid class of labourers.

With this conclusion, however, it is very compatible to suppose, that individuals in the class of beggars, those who have more skill and industry than the rest, may attain to considerable gains; as it is evidently an occupation in which a greater or less degree of skill in working upon the attention and sympathy of mankind must make a considerable difference. The greater you suppose the gains of these skilled individuals to be, the smaller, of course, must you suppose the number of those who make them.

7. We have now exhibited what appears to be the result of all the evidence yet before the public, respecting the actual state of mendicity. The information is exceedingly imperfect, while it is certainly not very creditable to the legislation of our country to be thus ignorant upon such a subject.

It remains for us to present what the existing state of information enables us to discover with regard to the *causes* which operate in this, our own country, to the production of mendicity; in the next place, to explain the *effects* which it is of the nature of mendicity to produce; and, in the last place, to give a list of the operations which appear likely to be the most powerful in effecting a *remedy*,—the object and end of the inquiry.

Causes of Mendicity. 8. With respect to the causes of British mendicity, it will be useful, in the first place, to give what dropped in detail from the witnesses before the Committee.

The cause of which they first begin to speak, is what we may call, in one word, *soldiering*, or the unfavourable change produced in the minds and in the circumstances, both of individuals and of families, when the individuals, or those on whom they depend, become soldiers. There is nothing to which the minds of the witnesses appear to be carried more frequently than to this.

Edward Quin, Esq. a member of the establishment for sending the poor Irish to their own country, speaking of the persons whom they send, declares: "Most of those parties have been, I should imagine nine out of twelve, either in the army or navy, and mostly with families, who have no means whatever of returning home, except, perhaps, a temporary pass, twopence a mile, or a penny a mile; we have known a man, with a wife and six children, coming from the Peninsula, sometimes with 9d. or 1s. or 2s. a-day."

He makes a curious declaration with regard to the Irish, who are already begging in England. The establishment thinks it is better to have *them* in Eng-

land, as "to send them to Ireland, where there is no provision for them, would be doing them no good."

Beggar. Mr Colquhoun, the celebrated magistrate, and our grand instructor on the subject of police, being asked for his opinion of the causes of mendicity, said,— "It does appear that there are various classes of mendicants, which are all pretty numerous: First, those that are beggars by profession, who are the immediate objects of the attention of the police. Secondly, those that, from temporary pressure in the winter season, and other seasons when work is slack, or they have any special pressure upon them, fall into want, such as *the wives and families of soldiers*, when their husbands are abroad; or when, from sickness, the head of the family is out of work, many of them have no resource but to ask alms in the streets; that class is forced to do so from the inadequate allowance the parishes can make them, partly arising from their not being parishioners, and arising also from the circumstance of the small sum the parishes can afford to allow, which seldom exceeds the weekly sum required for a miserable lodging. The next class, I am sorry to say, are persons, and *they are pretty numerous, who have allowances from Greenwich Hospital, or who are Chelsea pensioners*; they carry on the trade of begging to a pretty considerable extent. Strangers wander up to town, of which there are a great number, in search of work, with their families, and are disappointed, in consequence of the scarcity of labour, from the supply being greater than the demand; which has been evident to me, and very much so, from attending the very unpleasant duty of appeals against parish rates, and that discloses very often a great number of people out of employ: a number of those who have been wandering up, as well as those stationary in town, do obtain some subsistence, I apprehend, from begging. Those are all the different classes which occur to me at present."

Mr Davis, the agent by whom all persons taken up as beggars and vagrants in London and Middlesex, and passed to other counties, are conveyed, speaking of the difficulty of keeping them from running away, says,— "But the girls that come up with the soldiers are the worst we have; down at Woolwich or at Greenwich, sometimes I have a whole coach-load brought up at a time, some going one way, some another; if it is possible to get away, they will. Some of them say, We must go out of your district, but we will not promise to go all the way home."

The *Edinburgh Society*, also, for the suppression of beggars, say, in their first Report,

"The widows, where not charity work-house cases, were generally found burdened with families, frequently the widows of soldiers killed in battle. The married women were either old, or with families, their husbands being labourers out of employment, or soldiers abroad, many of whom had once enjoyed the county allowance as militiamen's wives, but who had been deprived of that resource in consequence of their husbands having volunteered into regiments of the line. There seems some reason to apprehend that the allowance to the wives and families of militiamen is gradually eradicating that pride which, with the lower ranks in this country, made parish

Beggar. support disgraceful, and the resource only of the utterly helpless and friendless."

We shall not lengthen this article by pointing out, because they are obvious to all, the circumstances attached to soldiering, by which it necessarily becomes a great source of beggary. These instances are sufficient to prove the impression which has been made by the facts upon the minds of those who have been situated most favourably for observing them.

The next circumstance which is stated by the witnesses before the Committee as a cause of multiplying beggars, is the *state lottery*. It is adduced by more of the witnesses than one, but we must remain satisfied with a specimen. Mr Wakefield was asked, "You have mentioned the lottery, as the second cause; have you any facts to state, justifying that opinion?—I beg to state a very strong instance of an apparently industrious man, who applied to the committee of the *Spitalfields Soup Society* for relief; he was told, that his appearance did not indicate want; and his mode of living was asked. He said he was a "Translator;" which is a business of buying old shoes and boots, and translating them into wearable ones. Inquiry was then made, if he had such a business, why he should then apply for relief; and he answered, as a matter of course, that the lottery was drawing, or about to draw. "Why, how can that affect your business?"—"I have no sale for boots or shoes during the time that the lottery draws." Inquiry was then made as to the truth of the statement, and it was found to be the case, and that he was an industrious and respectable man; and that it was only on account of the loss of his trade that he was brought into that distress.

"How long ago was that?—Two or three years ago; the money went, of course, either in the purchase of tickets, or the payment of insurances in the lottery."

Almost all the witnesses who deliver any opinion upon the causes of mendicity, mention the use of intoxicating liquors as one of the greatest. It is needless, we conceive, to adduce the testimony of any individual in this case. The only mistake, of which there is any danger, in respect to this cause, is the ascribing to it more effects than it produces. Though mischievous, in proportion to the quantity, by every drop that is consumed, it will account for but a small portion of the mischief which we behold.

Local demands for temporary labour often affect the poor very unfavourably. A passage already quoted from the evidence of Mr Gurney, shows in what manner a great number of persons crowding to the vicinity of London in the hay season, are driven or seduced into habits of beggary.

One cause of beggary may here be mentioned, which has not attracted all the attention which it deserves. That is, the mode in which we allow certain classes of the people to pay themselves by a sort of begging. In these unhappy circumstances we allow post-boys, stage-coachmen, and various other classes to be placed. One sort of begging is nearly allied to another. Of the same tendency is the practice by which servants take, and by their

Beggar. well known expectations beg, gratuities from their master's guests. All these are degrading practices, which bring down the mind to the mendicant level. We have no doubt whatsoever, that, of this sort of people, a greater proportion than of others, recruit the ranks of mendicity.

Almost all the witnesses represent the want of education, as standing high in the list of the causes of mendicity. Some of them who had used the greatest range of observation, spoke of this cause with extraordinary emphasis; and of the powerful effects of schooling, as giving that sense of honour to the people, which makes them willing rather to die than to beg. We shall not enlarge upon this cause, which would afford materials for a volume. It is enough, in this place, to mark the importance which the mere outward observation of practical men has drawn them to attach to it.

The poor laws stand branded by the witnesses as perhaps the most prolific of all the causes of beggary. The object of the poor laws is the very reverse. They are, by this account, the greatest cause of that which they were contrived to prevent. By making a sure provision for every body reduced to want, all motive for begging was expected to be taken away. The legislator looked only to one thing; where he had a great many things to which he ought to have looked.

Mr John Stafford, the chief clerk of the Police-office in Bow-street, said,—"I think it might prevent a considerable number of persons becoming beggars, if there was greater facility given to the magistrates to compel parish-officers to relieve poor persons who are in want, and unable to work or provide for themselves; for, as the law stands now, if a poor person comes to the magistrate to complain that he is in a state of distress, and does not know what to do to obtain relief, that person must apply to two overseers of the poor, who may refuse relief. The magistrate must then summon the two overseers to appear before him; and it is not until after they appear, or have made default, that he is enabled to make any order upon the parish-officers to relieve those persons; so that, in cases where the parish-officers are from home, or when they live at any distance, it requires frequently a day or two before a return to the summons can be procured; then, unless anything can be done in the meantime, the paupers have no means of obtaining relief, but by soliciting charity."

Sir Nathaniel Conant, the magistrate, describes the same evil in nearly the same words. Respecting the beggars produced by this cause he was asked,— "Do you think they constitute a large proportion of the beggars in London?—I cannot state that; there are a great many, almost all the persons not actually known in a parish, who have occasion to apply for parish relief, apply in their last extremity. They are shifted about from post to pillar for two or three days, before they can obtain relief. They beg at the corner of a street; they are taken up by the watchman; and when they are found to belong to a parish, they are let out, instead of being taken to the overseers. I conceive a good many of those who run after the passengers are in that situation. I con-

Beggar. ceive that, if they could go to the parish-officers at the moment of casualty, they would not be in the streets.

On this head, however, the information afforded by Mr Martin is the most important. It appeared by the Inquiry, of which he was the principal organ, into the State of Mendicity in the Metropolis, that about one half of the beggars in the metropolis in reality belonged to the parishes in the metropolis, and were there entitled to relief. This is most assuredly, in the account of English mendicity, a very extraordinary fact. It is worth while to give the proportions, as they exhibited themselves upon this Inquiry :

CLASS I. PAROCHIAL INDIVIDUALS.

Of Home Parishes; inclusive of			
about	1,384 children,	about	2,231
Of Distant Parishes; inclu-			
sive of	489 ditto	- -	868
Total Parochial Children,			
about	1,873		
Total Parochial Individuals, about			3,099

CLASS II. NON-PAROCHIAL INDIVIDUALS.

Irish; inclusive of about	1,091 children,	about	1,770
Scotch; inclusive of	103 ditto	-	168
Foreign; inclusive of	29 ditto	-	59
Total Non-Parochial			
Children, about	1,223		
Total Non-Parochial In-			
dividuals, about			1,997
Total Children on the 2,000			
cases, about	3,096		
Total Individuals on the 2,000 cases, about			5,096

Mr Martin observes, " It may appear extraordinary, that the parochial poor should be found to furnish above one half of the general mass of beggars in the metropolis. There are, however, two causes particularly affecting the parochial poor, which have doubtless contributed to reduce many of them to a state of beggary; viz.

" 1. The practice, generally prevailing in the metropolis, of refusing relief to paupers out of the work-house; and,

" 2. The want of a provision by law, to direct, in particular cases, adequate relief to parochial poor, not resident within the limits of their legal settlements."

It was observed to him, " If it be real distress and not imposture, it should appear that the proper place to apply for relief would be the place of their own settlement?—It is astonishing how ignorant the poor people are. A great many live in a contiguous parish to that to which they are chargeable, then they are afraid of the law which directs they should be either imprisoned or whipped, or removed home, in case they apply for relief; and some, who have been in better conditions in life, are very delicate in making their distresses known at all.

" Have you ascertained that?—Yes; even when I have written, I have frequently found the testimony in some degree corroborated I have received before; there may have been a variation in a few circumstances, but the general statement has been often true in those cases with which the committee

would be most surprised. A woman mentioned a great deal of property abroad (I think in one of the West India Islands) some time ago; I found there was ground for a great part of what she said, but not the whole.

" You think those persons did not know where to apply, till you informed them?—In many instances they did not know how to apply, or they have been so intimidated by the letter of the law they were afraid.

" Do you think a large proportion of those who applied, became beggars and applied for relief to you, because they did not choose to go to their parish?—I think there were some, but their motives for that were very various; in many cases it was entirely timidity.

" You have mentioned in your printed letter of 1811, as one of the causes for beggary, the want of a provision by law to direct, in particular cases, adequate relief to parochial poor not resident within the limits of their legal settlement; what do you mean by that?—I mean, that supposing there is a man belonging to Liverpool who is a coachmaker's smith for instance, or in some employ in London, and that he falls into temporary distress by sickness; the distress of that family is enhanced, and often goes to the excess of making the wife pawn even the working tools of her husband: if they could immediately go to any magistrate, and claim the necessary relief, to be afterwards refunded by their parish, that distress would be prevented."

To Mr Colquhoun, the magistrate, it was observed,—" You have given it as your opinion, in your *Treatise on Indigence*, that among the causes of vagrancy is the hardship and dread of removals?—I look upon the removal as one of the greatest evils attaching to the pauper system; if that could be done away by legislative regulation, so as to let the burthen fall equally upon the country at large, that would do more to reduce the rates than any thing else: it is a lamentable thing. I know in the year 1800, that in Braintree and Bocking in Essex, although the average of the whole country was not above 5s. 6d. in the pound, they paid actually 40s. in the pound for poor rates, which amounted nearly to a disinherison of property, in the hands, perhaps, since William the Conqueror, of some of the proprietors; and I know of property which would let for L. 200 a year in any other part of the country, letting for L. 20: And I remember another instance, of a person who had established a nursery; he was rated for that nursery L. 70 a year; it had cost him L. 800; and the question with him was, whether it would not be better to abandon it than sustain the burthen. Wherever you see in England the finest surface of country, such as Hertfordshire, and all the southern counties, there you have the greatest portion of poverty: In Sussex, by the last returns, it was 25 in the hundred, that was, a fourth part of the population; in Cumberland, five; in Lancashire, where we should expect more poor than any other, from the fluctuation of labour, 17.

" Do you conceive, that the system of removals at once adds considerably to the expence of the rates, and is a great grievance to the morals of the poor?

Beggar. —That it degrades the poor to a very great degree is certain; and that it adds to the rates, but mostly in the metropolis. The managers of the poor are very willing, thinking to get rid of them in a short time, to maintain them, rather than send them to a remote quarter; if it is within 20 or 30 miles, they will remove them, but if it is 200 miles off they do not go to the expence.

"Then they must have the paupers perpetually upon them?—They are in hopes of soon getting rid of them; they often go into the house from the sickness of the head of the family, or from various casualties; they are in hopes things may come round."

Of the existing system of extraordinary laws concerning the poor in England, that part which relates to the whipping and imprisoning of persons found soliciting alms, is represented by the witnesses as one of the grand sources of evil; because it is a law which the present state of humanity will not allow, in ordinary cases, to be executed. The whipping is regularly and totally disused. The putting a wretched being into an English prison is not a way to elevate his mind, and place him above the base thoughts of beggary. It is likely to make him more regardless of all moral, very often of all legal restraints; and where he went in a beggar, to come out a thief. Upon the atrocious cruelty of driving a wretched creature to beggary, in the way explained above, by refusing prompt assistance, and then whipping or imprisoning for an act of such necessity, no comment is required.

Into the mischievous tendency of the principle upon which the system of the English poor laws is built, holding out a premium for worthlessness, and for that excessive multiplication of the people, to which a state of general wretchedness is attached, we shall not at present enter. It will come to be considered, where THE POOR, and the policy regarding them, become the subjects of discussion. What, in this place, chiefly calls for attention, is the course of procedure and detail, in the hands of the parish officers; not as a system of waste and of oppression upon the contribution, nor as a system of tyranny and vexation to the paupers, but as a mode of making beggars. This they do, by their modes both of giving and withholding relief. They give it under such circumstances as to make people fly from it to beggary; they withhold it in such a manner as both to compel and seduce them into beggary. Mr Gurney was asked,—“What is the police establishment of your parish?—We have four beadle and six constables, besides special constables occasionally; but there is a great terror and alarm on the minds of the parish officers of all the parishes, lest the work-house should be overstocked, and lest the parish should be burthened; and, as long as persons get their livelihood without looking to them, though it is by pilfering, unless they actually know that they are pilfering, they take no notice. I have often thought that if many of our poor laws were imperative, instead of permissive, it would be useful; and I am afraid many of the parish officers are ignorant of their duty, as well as the beadle and constables.

“Do you know whether persons confined in the work-houses, and relieved there, are ever let out of

Beggar. those work-houses for the purpose of begging, in the course of the day?—They go out on the Sunday generally, and I believe many of them beg, indeed I am pretty sure of it.”

As a cause of beggary, it is necessary here to mention *early and improvident marriages*, and all those other proceedings which tend to increase procreation beyond the measure of subsistence, and thus to keep the great mass of the people sunk near to the level of mendicity,—a proximity from which, by the slightest accident, many of them are continually falling down to it altogether. That this is the grand medium through which beggary is produced, it is needless to offer any proof. The mode in which the principle of population, when injudiciously encouraged, instead of being wisely restrained, operates to the degradation of the people, has been already, in part, explained; and it will be still farther elucidated in a subsequent article of this work.

Among the causes of beggary in England, one may be regarded as pretty remarkable, that is, *Ireland*. Ireland is one of the greatest of all the causes of beggary in England. Considerably more than one-third of all the beggars in the metropolis appear to be Irish. Of all human beings in any part of the globe, the mass of the Irish appear to be in the most deplorable circumstances, whether their moral or physical situation be considered; and that under a government regarded as the best in the world. The art of making governments efficient to the purposes of government is, therefore, still but imperfectly understood.

Some of the witnesses, Mr Colquhoun in particular, bring forward a very important subject. They give the state of the criminal laws as one of the chief among the causes of mendicity.—“About 5000 individuals,” he says, “are vomited out of the jails, without character. These people come on society, without any asylum provided for them. If such an asylum could be established, I think, in a very short time, it would relieve the town of a great many of the beggars.” The operation of the penal laws upon the moral state of the people is a field of inquiry far too extensive to be introduced into the present article. That an ill-contrived system of correction for offences may degrade the minds of a people, destroy their sensibility to moral considerations, render many of them incapable of that self-esteem, on which the abhorrence of becoming a beggar is founded, nobody can help perceiving. That a great part of the British system of penal law is infected with this tendency, has long been the complaint of discerning and philosophic minds. The public is not a little indebted to the popular writings of Mr Colquhoun, for the degree of attention from men in power which it cannot long be hindered from receiving. Another place in this work will be found for giving to the subject that degree of elucidation which it so highly deserves.

Of all the causes of beggary, *war* may undoubtedly be assumed as one of the most extraordinary. We have already seen in what manner the people converted by it into soldiers swell the ranks of mendicity; but this is only a small part of the deplorable effects. It brings the condition of the whole of the

Beggar. labouring mass down nearer to the mendicant level; and, of course, a new and additional portion down to it altogether. This it does by the consumption which it produces. Exactly in proportion as money is spent upon war, exactly in that proportion is the condition of the people, destroyed; exactly in that proportion must the people, *cæteris paribus*, sink. These are conclusions which may be regarded as scientific, and which will never be called in dispute except by those who are ignorant of the subject. It is not impossible for war to be accidentally accompanied with circumstances which counterbalance this tendency, even in respect to wealth; but this is exceedingly rare. The great men very often gain by war: the little almost always lose.

There is one other cause of mendicity, which it is incumbent to mention, because it really includes all the rest; but it can be very little more than mentioned, as it is far too extensive for elucidation in this place. This cause is *legislation,—bad legislation*. An argument, which, though it is too general deeply to impress a mind unaccustomed to generalize, is in fact almost demonstrative, may be given in a few words. Perfect legislation, a legislation capable of turning to the best possible account the command which in this world man possesses over the good things of life, would so conduct society, that, as there would be scarcely any individual who would not, by his moral qualities, deserve, so there would be not one who would be left without the means of corporeal well-being. If this proposition be correct, it follows, as an unavoidable consequence, that every beggar who exists is, in some way or another, the effect and consequence of bad laws. Exactly in proportion as we can make our laws do more of that which all laws ought to do, we shall diminish the number of those who approach the level of mendicity; and at last dry up every source from which it springs. And in the meantime, exactly in proportion as a greater number of the mass of any people are either at, or approach to, the level of mendicity, in that proportion infallibly may the laws be pronounced to be bad.

Effects of
Mendicity.

9. We have now stated what the present occasion appears to require, on the subject of the *causes* of mendicity. We proceed to the *effects*, which, being a much less complicated subject, will be much more quickly dispatched.

The effects may be considered as bad, first, in respect to the beggar himself; next, in respect to the community.

With respect to the beggar himself, they are bad exactly in so far as he is less happy in that state, than he would have been in any other in which it is in his power to place himself. If it was not in his power to have placed himself in a situation above suffering to a greater degree for want of the means of well-being, he suffers nothing bodily; perhaps he even gains, if the bodily pains of begging are less than those of the labour to which he would have been doomed. He may suffer in his mind, by the sense of degradation. But when that ceases to be an object, this pain is at an end. In as far as he is

Beggar. likely to be more intemperate as a beggar, he injures his health, and destroys the pleasures of sympathy. And in as far as he is less religious than he would otherwise have been, he is a loser in respect to the hopes which religion bestows.

If he has fallen to beggary, by his misconduct, from a superior state, in which he would have enjoyed more happiness; of this loss, whatever it is, beggary is not the cause, but the previous misconduct. The question is not, what he would have been, had he not lost what he has lost by misconduct, but what, having made that loss, he can now do that would make him happier than begging. If a mind is well educated, and its sensibility to moral considerations acute, almost anything would render it happier than begging. If it is in the brutal state of an uneducated mind,—a mind which has never had its moral sensibility sharpened, few things would render it happier that did not afford it in greater plenty the means of sensual indulgence and ease.

These, such as these, are the considerations by which we should endeavour to estimate the loss of happiness which beggary produces to the generality of beggars *themselves*.

Let us next endeavour to estimate what is lost through it by the community to which the beggar belongs.

There is, first, the loss of his labour, provided he was able to work. He consumes without producing. In this particular he is equally mischievous with every useless soldier, every useless functionary of the state, and not more. Not so much, indeed, as often as their consumption is greater than his.

If the beggar is unable to work, the public, in a pecuniary sense, loses nothing by his beggary, because, it being not proposed to let him die of hunger, he would have been maintained in all events.

What remains, exclusive of moral effects, is only the annoyance which is given to the people at large by the solicitations of beggars; by conveying to them disagreeable impressions through their eyes and their ears. We shall not reckon this for absolutely nothing. But sure we are, that all the amount of pain which in a year is produced in this country by that cause is very inconsiderable. There are exhibitions of sores and filth, and a degree of importunity which we can conceive amounting to a pretty serious nuisance. But these things, we see, it is very easy to prevent.

We come now to the moral effects produced by beggary, which, except in regard to the beggars themselves, in which respect they have been considered already, consist entirely in example; in the tendency which the immorality of beggars has to produce imitation.

But it is the privilege of beggars that their vices are not contagious. The vices of the great infect the whole community. The vices of beggars infect nobody but themselves.

We do not think it is necessary to pursue this subject. The evidence appears to be satisfactory, that beggary, when considered as a *cause* of evil, turns out to be a cause of no great importance. Of the inconveniences sustained by the nation, a very

Beggar. small portion can be traced to beggary. For even the loss of labour, which is the main article, is very inconsiderable, as the number of able-bodied mendicants is very small, compared with that of the very young, the very old, the mutilated, and diseased.

In the case of beggary, as of many other results in an imperfect state of the social union, the disapprobation and hatred of the mind are very apt to be misplaced. We abhor beggary, but it is the causes out of which beggary springs, and from which, along with begging, infinite other evils arise, that deserve almost all our abhorrence.

Expedients for suppressing beggary. 10. We come now to consider the remedies which may be applied to the disease of beggary; the *facienda*, in short, the things to be done for its removal.

The first and most natural course would be to go to the list of causes; the excess of multiplication, and consequent poverty of the mass of the people; the want of education; the poor laws; the criminal code; wars; and in one word including the whole, bad legislation. Take away the causes, and the effect immediately disappears.

As among the causes of beggary, however, there are some, and these among the most powerful, which cannot be easily or speedily removed, it remains to inquire what, in the meantime, can be done to check their operation.

The first question is, what can be done by the operation of the existing laws.

The following testimony was given by Sir Nathaniel Conant:

"You think if there was a strict execution of the laws now in force, the streets might be cleared of the beggars?—Certainly.

"In what way would they then be disposed of under the existing law?—If they were taken in the act of begging in an individual parish, they must be sent into the Bridewell for seven days at least; then a pass must be made to the place of their last settlement; if that is not found by the examination of the Justice to his satisfaction, he sends them into the place of their last residence, the place where they were taken; that parish is to fight against them as well as it can, that is, by bribery, if it can be called so, by giving them relief and letting them slip out of doors.

"What becomes of them then?—Then they begin again; the existing law will clear them, but it is only for a day.

"Then the laws, as at present constituted, are not sufficient for clearing the streets?—My answer to that would be, that the nature of such a town as this is such, that they cannot be cleared in those intervals which occur between the application and the relief given; there will be distress and hunger, which will drive the paupers to mendicity.

"Then, if they are passed to a parish near to London, they may be engaged in begging again in eight and forty hours?—Yes, in less than that; and where they are passed to distant parishes, there are perhaps only two or three farms; the occupiers of those farms are very unfit to have the care of such persons, perhaps, from their age or their sex, and very unwilling to have such pensioners.

Beggar. "Can you suggest any alteration of the law, which would have the effect of clearing the streets?—I think that might be effected by a strict execution of the existing laws; but that would introduce such a degree of severity as to a considerable part, not perhaps half, that it would be quite as great as the laceration of the mind of the passenger on seeing such objects.

"The question refers to the case of persons returning to their parishes, and then beginning begging again?—The nature of the legislation of England is, that it always goes upon the idea of the whole, and not of a crowded metropolis; and it supposes the profligacy or industry of each individual to be known.

"You were understood to state, that when a person was taken up, he was sent to Bridewell for seven days, then passed to his parish, and that, if that parish was in London, he then returned to a state of mendicity. Can you suggest any alteration which would prevent the beggar who had been in Bridewell, and who had been passed to his parish, returning to a state of mendicity?—Parliament might compel the parish to maintain them until they are enabled to obtain their own livelihood, according to their age, or strength, or sex; but nothing less than that would do, for the person goes out without clothing sufficient for a decent occupation."

Sir Nathaniel had stated, that he did not give orders for taking up the beggars with all the strictness of the law, and gave the following as his reasons:—"That if I did give those orders this morning, I should have those that are impostors all run away into the next street, only so to elude the people to whom I gave the directions; and I should have blind and imbecile creatures, who had no claim at all upon the justice of the parish in which they happen to be taken, though that parish would, in the first instance, be made liable to them, if I passed them into that parish after sending them to prison for a week, which the Act of Parliament necessarily includes; for no pass can be made till they have been in prison a week. If they were passed into that parish, the parish-officers would, in their policy, and in justice to their neighbours, say, "Why do you come here? you come here as a beggar, and have been punished; here is a shilling, go about your business, and get yourself conditioned in some other place." They would walk down below the Tower, and beg there for another week, and then get up again into Westminster, and continue the practice of begging, having no settlement perhaps.

"Supposing the magistrates were to follow the letter of the law, might not they be all removed from the neighbourhood of the metropolis?—I think they might; I think the practice established at Edinburgh might be practised here, but with dreadful cruelty to two-thirds of the persons subjected to that mode of subsistence. In Edinburgh, they act with extreme severity to every person found in a state of mendicity."

Sir D. Williams gave the following testimony:—

"Do you take any steps, through the medium of your officers, to take up beggars?—We have given instructions generally to take up all beggars; and it

Beggar. has been done also by several parishes in the neighbourhood, who have directed their beadles to take them into custody.

“Is it your opinion, that if the same mode was pursued by the other magistrates in different districts, that many beggars would be prevented from pursuing that course of life?—There can be no doubt of it.

“You consider the present laws sufficiently strong, if those laws were put in force?—No doubt.

“And that if the magistrates were to put the law into force as it now exists, public begging might be prevented?—There can be no doubt of it.

“You consider that the laws might be so far put in force, as to clear the streets of beggars; have the goodness to state to the committee the process which takes place with the beggars found in your district?—Any person has a right to capture a beggar in the act of begging; he is to take him before a magistrate; the magistrate, by the confession of the party himself, or the oath of another party, is bound to pronounce him a rogue and vagabond, and send him to the House of Correction for the county of Middlesex; there he remains seven days, and is passed by the pass-master of the county to the next parish leading to his settlement, and so forward till he arrives at the place of settlement; and for which the person capturing the mendicant is allowed by law 5s.; there is a premium for it.

“Supposing the parish to which he actually belongs remains within your district, or is that in which he is found begging; there is nothing to prevent him, on his return, resuming the same practice of begging?—The law will prevent that, by sentencing him as an incorrigible rogue, to six months imprisonment, if he has been pronounced a rogue and vagabond under the first charge.

“Are those steps frequently taken by you?—They are brought before the Court, and the Court adjudges them to a further imprisonment.

“How long do they remain there?—Seven days in the first instance, and six months in the second.”

Patrick Colquhoun, Esq. to whom, primarily, his Country is indebted for all the knowledge it has recently gained, and all the improvement it has made in Police, delivered the following testimony:—“Of late it is inconceivable the number that have received passes from the magistrates to go to their different parishes; which we give now, though directly in opposition to the Act of 1792, which requires they should be previously whipped or imprisoned a certain number of days, and then passed as vagrants to their parishes; that Act has been found impracticable. It arose from the Lord Mayor and the magistrates giving innumerable passes, of which I am afraid many make the very worst use; but we are very glad to get them out of the town, that they may be subsisted in the quarters to which they belong, or where they have friends; in that way we are relieved of a very considerable number, who must otherwise beg in the streets.

“Do you conceive that the laws as they at present exist relative to beggars, if put into due and strict execution by all the magistrates in London and its vicinity, would be sufficient to clear the streets of beggars?—I do not indeed; there have been at-

tempts made at different times, and they have all failed. I think the Act of 17th Gen. II. totally inadequate to the purpose; it is loosely worded; it is not at all adapted to the present state of society; and that Act ought to be revised from the beginning, and adapted to the present state of society.

“Do you mean individual and separate attempts?—I mean to say various attempts have been made, by taking up the beggars; the expence is enormous on the county rate. I believe at one time there was more than L. 100 paid to the office I belong to, in the course of the sessions.

“If all the magistrates were to unite, the magistrates of the city of London, the magistrates of Westminster, and the magistrates of the vicinity, to put the laws in execution, do you think that would be successful?—As far as my judgment goes, if the whole were to join their efforts it would not succeed.”

The beadles complain that when they take up beggars the magistrates discharge them. One of the beadles of St George's, Bloomsbury, said, “I took up a man yesterday that I observed knocking at every house, regularly, in Bloomsbury-square, two or three days ago. He was again yesterday taking every house regularly; I waited till the servant came to the door, and he then put a petition into her hand; I took the petition from him, and took him to the watch-house. I found three copies of the petition upon him. I took him to the office in Hatton Garden, and the magistrate discharged him.

“Did the magistrates examine you upon your oath?—They did; and I told them I had removed him out of Bloomsbury-square, three days before, in consequence of great complaints of the inhabitants, that those persons were suffered to be about.

“You stated upon your oath, to the magistrate, that you believed him to be a common vagrant?—Yes; he paused a quarter of an hour upon it; and he said, the prison was so full of people that he thought it not right to commit him there. He talked of sending him to the New Prison, and the clerk said it must be the House of Correction. I told him I should not object, if he thought proper to discharge him, which he did. The magistrate told me, if I saw him again, I might bring him. I could have taken four beggars up on Sunday, but if we take them down they discharge them.

“That is the practice of the magistrates?—It is. I have taken many and many down, and they have been discharged; and my brother beadles will give the same testimony.”

Mr Mills, a gentleman who had been Overseer of the parish of St Giles, stated, “We used to take them to the magistrates, and take the recourse the law provided; but, in fact, the magistrates themselves would have loaded the prison, they were so numerous. In our parish there was no end to the commitments which would have taken place. I have sat with my brother officers from two o'clock in the afternoon till eight in the evening, constantly relieving those persons.”

It thus, we think, sufficiently appears, that the law for the compulsive prevention of beggary cannot be executed, or, more accurately speaking, it is unfit for execution; it cannot be executed without

Beggar.

Beggar.

Beggars.

producing a much greater quantity of evil than it seeks to remedy; and therefore the magistrates take upon them, without scruple, to violate it, and leave it without execution.

Of the things to be done, one, then, most obviously suggested, is a *review of the existing laws* which relate to beggary; the repeal of all the enactments, which are ill adapted to the object in view; and the passing of other enactments which may possess the greatest practicable degree of adaptation and efficiency. Into the detail of these enactments, it is not here the intention to enter, because they must embrace the provision which is made for the destitute; the questions relating to which, we reserve for the article on the Poor.

Another of the remedial operations, importunately demanded, is to make provision immediately for the careful and efficient education of the whole mass of the population, down to the lowest individual. On the potent connection between good education, and that sort of conduct which keeps people above the level of mendicity, as well as on the mode in which education should be provided, our sentiments will be given with more propriety on another occasion.

As the tendency in population to increase faster than food, produces a greater number of individuals than can be fed,—as this is the grand parent of indigence, and the most prolific of all the sources of evil to the labouring portion of mankind, take all possible measures for preventing so rapid a multiplication; and let no mere prejudice, whether religious or political, restrain your hands in so beneficent and meritorious an undertaking. It would be easy to offer suggestions on this head, if we were not entirely precluded from going into detail. It is abundantly evident, in the meantime, that indirect methods can alone avail; the passions to be combated cannot be destroyed; nor, to the production of effects of any considerable magnitude, resisted. With a little ingenuity they may, however, be eluded, and, instead of spending themselves in hurtful, made to spend themselves in harmless channels. This it is the business of skilful legislation to effect.

In cutting off other causes, cut off Ireland; we do not mean literally; but what we mean is, that the mode of governing Ireland should be so reformed, as to make it able to send to England something better than a mass of beggars nearly equal to all her own.

Make a law to prohibit all modes of paying the people, which have an affinity with yielding to the cravings of a beggar.

Take all proper methods of rendering universal and preserving alive that exquisite moral sensibility, which is possessed by so great a portion of your population, and makes them willing to die of hunger rather than beg.

Provide a proper asylum for rearing to virtue the children of beggars; and let no person who begs be allowed, on any terms, to retain power over a single child; that, at any rate, you may prevent any portion of the young from being reared to beggary. This is an easy, obvious, and most important part of a good plan for lessening or extinguishing the evil of beggary.

Beggars.

Reform your criminal code; and cease to deal with offences in such a fashion, as to make the indigence of your people greater, and the virtues less, than they would otherwise be.

Under the head of improvement in the criminal law, it may be fittest to speak of that indispensable instrument for the cure of beggary,—a system of *Reformatories*, or houses in which bad habits may be eradicated and good acquired. On this point, some of the witnesses, whose testimony is entitled to the greatest respect, used a language unusually strong. The chaplain to Bridewell Hospital said, “I have long thought, *seeing so much misery as I have done*, that, as to remedy, very little could be done, unless you deprive the beggars of the pretext of begging; that that could be only by a *large penitentiary system*.”

“Has it occurred to your mind, that there could be a *Penitentiary* large enough to include all those persons?—I have not proposed one for the whole town, but four or five at different parts of the town.”

“Did you propose this for persons having settlements in the country, and others?—Yes; that every person knocking at the door might have admission, and that no person should have a pretext for begging in the streets. If a committee was sitting at either of those Penitentiaries, and work was going on at them, that would relieve from part of the expence; the *great advantage that appears to my mind is, the investigation of each case*. I do not know any place in town where that can be done. I have frequently thought, that unless there could be such a system as that to which I have alluded, the clearing of the town is hopeless: The great mass of misery which floats in this metropolis, I am fearful can never be removed, unless there is such a penitentiary system as that to which I have alluded: the two societies established for the reception of such persons are far too confined.”

“If one, two, or three large ships could be fitted up with good accommodation, do you think such places could be substituted for penitentiary houses, till the parties were disposed of?—I never but once saw any thing of the kind, and that was at Sheerness some years ago, when I think the sailors’ wives lived in two large hulks drawn up on shore; but there appeared to be so much misery and wretchedness, and they were so close and confined, that I did not form a favourable opinion of it.”

“The question supposes the ships to be fitted up in an airy manner, with convenient apartments, that would receive nearly as many, at little or no expence to the public, as the Penitentiary House now building at a very great expence?—The penitentiary houses, as proposed by me, would include workshops and rope-walks, and so on.”

Mr Colquhoun was asked,—“Do you think there could be any law devised by which there could be a possibility of furnishing relief to that class of persons who may be properly called beggars, by which they could be removed out of the streets?—I think it is perfectly possible to lessen the evil in a very considerable degree, but it must be by legislative regulation, and at pretty considerable expence. The situation of this town, to which so many wander up, is such that there must be an asylum for beggars,

Beggars.

with a species of work-house, or what I would call a Village of Industry, that would apply to all. That struck me so strongly in the year 1792, that I wrote a paper on the subject; and I believe if the war had not broken out, it would have taken place. About 5000 are vomited out of the jails, without character; those people coming on society, it would have been a most desirable thing to have had an Asylum for them; but it was so gigantic a thing, that that prevented its being carried into effect. If such an Asylum could be established, I think in a very short time it would relieve the town of a great many of the beggars; but the magistrates must necessarily have some place to send them to.

"The Committee have been informed, that, within these few weeks, as is customary at this season of the year, there have entered London about 5000 persons of the labouring class, probably many of the mendicant class?—I cannot speak to the number; but I have no doubt of it.

"Would your plan of an Asylum go to the relieving those persons?—It would go to the relieving all persons who are mendicants, or had lost their character, by being committed for petty offences to the different prisons of the metropolis."

This, undoubtedly, is the right idea. Provide a system of Reformatories as perfect as they might easily be made, and you may accomplish every thing. Deprive yourselves of this important instrument, and you can do but little to any good purpose. A more appropriate place for describing this measure in detail, will occur more than once hereafter. We know, however, only one good plan, and that is before the world already, in Mr Bentham's *Panopticon*. Apply this, with the system of management which he has contrived for it, and if you do not extinguish the evil of pauperism, in all its degrees, you will undoubtedly reduce it to its lowest terms.

In the testimony given by the chaplain of Bridewell, as we have seen in the preceding quotation, he mentions, "the investigation of each particular case of beggary," as an advantage of the highest possible kind.

Mr Butterworth said,—“ I conceive that no plan of relieving the poor is so effectual as that of visiting them at their own habitations; and even then, inquiry must be made of their neighbours, to know their real characters, as persons in the habit of begging are adepts in the art of imposition.”

Mr Cooper was asked,—“ In what way do you think poor families may be mostly benefited by the exercise of benevolence?—I know of no way more efficient than that of their being visited and relieved at their own habitations; and, in fact, as far as my observation and experience go, there is no certainty whatever of any donation being properly applied, without investigating the circumstances at their own habitations.”

We deem these testimonies of great importance; as we are convinced, that what is here recommended, a distinct investigation of each individual case, rendered co-extensive with the population, would be attended with innumerable advantages.

To render this investigation practicable, without

Beggars.

enormous trouble, and, indeed, to render it possible with any tolerable degree of exactness, another and a most important operation is required, subservient to an infinite number of good purposes; and that is, a proper system of registration. The whole country should be divided into sections, containing each a moderate number of inhabitants; the names, residences, and descriptions of the inhabitants of each section should be entered in a public record; and means employed (as much as could be without incurring any serious inconvenience of a different sort) for placing the people of each under the full inspection of one another. How important a check this would be on improper conduct of every sort is intuitively manifest. How easy, too, it would render the business of visitation, and what perfect knowledge it would afford of the circumstances of each individual case, it is impossible to overlook.

The importance of registration was not unknown to some of the witnesses before the Mendicity Committee. Sir N. Conant observed,—“ In a town like this, where no creature knows the inhabitant of the next house hardly, or their character, and especially among the poor, the overseers of parishes ready enough at all times to spare if they can, by any kind of indulgence (I was going to say) the parish purse, are always willing to put at a distance every person who applies, being entirely ignorant either of their character or of their necessity. Until they are forced to take them in, and give them relief, they seldom do, unless they know them, and they know very few of the inhabitants even of their own parish, in the very nature of the thing; this applies to any condition of life, and more especially to the poor; that introduces another class of mendicants, which are people deserving of parochial relief, in the interval before they get it. If the paupers apply to-day to the parish officer, being settled in their parish, they are not known to him; and the parish officer either says, he shall make some inquiry; or, that they look strong and hearty, and able to maintain themselves, or that their families may be imposed upon them, and that he shall inquire and see, and they may work.”

We find Benefit Clubs, and Savings Banks, held forth as means for the preventing of beggary. But we question, whether the sort of people who apply to savings banks and benefit clubs are apt to become beggars. We see, that those among the common people, who have had any moral feelings implanted in them, will in general die rather than beg. We see also, that the having a provision already made is no security against mendicity, when the mind is worthless; because many of the Greenwich and Chelsea pensioners beg, and are among the most troublesome of all beggars. It would surely not be difficult to find a better mode of paying these pensioners, so as to afford a check upon their vices. Some way might also be found of punishing those parishes, who, when a beggar is passed to them, instantly let him out again, to prey upon the public. When a beggar appears, if it is resolved to suppress them altogether; or when he acts in any such manner as to create a nuisance, if it is only proposed to suppress what is noisome about them; it should al-

Beggar. ways be easy at the moment for any passenger, or observer, to put in execution the means of taking them up. For this purpose, it would be necessary that a constable or beadle authorized for this purpose should be in every street, and his residence rendered conspicuous to all the passengers.

Under the head of remedies for the disease of beggary, it is necessary to speak of societies for the suppression of it. In the first place, it is abundantly evident, that an assemblage of private individuals have little power over the chief causes of mendicity; over wars, for example, excessive procreation, and bad legislation. They can only endeavour to counteract, by such powers as they possess, the operation of these causes. They may, indeed, contribute *indirectly* to the removal of the causes; namely, by holding them up in their true colours, to the legislature, and to the nation. This, it may be observed, in one of the ways in which they may effect the greatest quantity of good; may, in fact, advance with the greatest expedition to the accomplishment of their own end. With the means possessed in this country of operating upon the public mind, and the influence of the public mind upon the legislature, a society of gentlemen, rendered conspicuous by their union, and the beneficence of their proceedings, might, by representations, sufficiently persevering, and sufficiently strong, more especially if the operation was not confined to one society, but common to a number of societies, in numerous parts of the country; effect almost any improvement of which the nature of the case would admit.

Society at Edinburgh for the Suppression of Beggary.

The first idea of a Society of this sort, as far as we know, was started in Edinburgh, and there carried into execution in the year 1813. The sole object of this society appears to have been to try what they could do for the cure of beggary, under the existing laws. There is no evidence of their having elevated their views to the thought of operating through the public upon the legislature, and through the legislature upon the sources from which mendicity flows.

In the sphere which the *Society of Edinburgh* have chalked out for themselves, it is impossible for us not to bestow upon their proceedings the highest encomiums; since they have put in practice, as far as it lay within their power, the principles which we have here recommended as the groundwork of reform.

In the first place, the *Visitation principle*:—"The basis of the whole plan," says their Report, "was to be investigation, and personal inquiry."

Secondly, the *Registration principle*:—"For the sake of facilitating the task of making such inquiries," continues the Report, "and the labour of superintending the poor, as the only means of preventing fraud and imposture, it was necessary to divide the city into separate wards or districts." From the want of legislative powers, however, it is abundantly evident, that they could perform the work of registration very imperfectly; were obliged, in fact, to content themselves with the registration of those persons exclusively who applied to them for relief; and instead of placing them effectually under the

Beggar. superintendence of the district itself, to take the labour of superintendence wholly upon themselves. If the business of registration, thus imperfectly performed, is yet an important instrument, how much would that importance be increased, if it were performed completely by legislative regulation.

Thirdly, the *Reformatory, or Employment principle*: The society is divided into four committees, of one of whom the business is to find employment for those of the applicants who are able to labour. It is evident under what prodigious disadvantages they carry on this part of their beneficent work. To perform it with any degree of completeness, a great establishment, such as those which have been called penitentiaries, houses of industry, reformatories, or panopticons, is required; an establishment in which different species of work may be carried on with all the accommodations which belong to them; in which the parties may work under the most complete superintendence; and in which they may be as completely as possible exposed to the operation of all the salutary motives which can be brought to bear upon them.

Fourthly, the *Education principle*: The children of the beggars are clothed, and sent to a Lancastrian school; and so important is this part of the business of the society accounted, that one of the four committees is wholly employed in conducting it.

What the Society professes is, to provide subsistence for all those who really are deprived of it, and of the means of providing it for themselves; and upon the strength of this undertaking the police of the city prohibit begging, by imprisoning and removing the beggars.

The only question which applies to this expedient regards the power of the Society to accomplish all which they undertake. If they can make provision for all who really and truly are in want; to prohibit begging is then to prohibit imposture, and can produce nothing but good. And if, along with this, they are able to make the distinction completely between those who are and those who are not able to provide for themselves; and to draw the benefit of labour from all who are capable of it; as far as there is any evil in mere begging, beyond the evil of being reduced to the begging condition, which is the principal, it is removed. It is not absolutely impossible that such an expedient as that of the Edinburgh Society, at one particular place, and one particular time; namely, when taken up with extraordinary ardour, owing to some particular concurrence of circumstances,—as in Edinburgh at the era of a new System of Police; or to the ardour of one or more individuals of sufficient influence to set a fashion, may, to a considerable degree, succeed. But it is abundantly certain, that it is not calculated for general or permanent use. How could it be applied to London, for example?—Besides; a great national benefit can never rest with safety on any thing so precarious, as the chance of extraordinary virtue in particular men.

(F.F.)

Bejapour. BEJAPOUR. The great peninsula of India is divided into several extensive kingdoms, which are partitioned into subordinate states of different denominations. Some were powerful sovereignties, enjoying a distinguished rank in the scale of nations, and subsisting during many centuries in splendour, as the empire of the Moguls; while others, as the Mysore, constituting the dominions of Hyder Ali, and his son Tippoo Saib, were of more recent formation, and owed their aggrandizement to the weakness of their neighbours. Bejapour is a large province in that part of India called the Deccan, extending from the 15th to the 19th degree of north latitude, and intersected by the 75th degree of east longitude, passing nearly through its centre. It is calculated to be 350 miles in length, by at least 200 in breadth, and thus is about equivalent to England in size. This province is bounded on the north and east by the provinces of Arungabad and Beeder, on the south by North Canara and the river Toombudra, and on the west by the sea. The western coast, for the space of 200 miles, is denominated Concan, forming a subordinate district, which has been long noted for the piracy of its inhabitants, who find secure retreats in the numerous bays and inlets on the shore, and a ready market for their plunder.

Boundaries.

Rivers.

Bejapour is watered by many fine rivers, of which the principal are the Toombudra, Krishna, Beemah, and Gutpurba. The last exhibits a tremendous cataract, perpendicularly precipitated from a rock 174 feet high; where the river, during the rains, is 507 feet wide. A great range of mountains, being the continuation of the western Ghauts, traverses the province 40 or 60 miles from the sea, through which are several passes of long and painful ascent, leading to the more level parts of the country. Their height intercepts the passage of the clouds, and numerous streams pour down from them, which, in the wet season, are swelled into irresistible torrents, spreading over the plains; but where low and smooth, they are crossed by travellers in large round baskets, covered with hides, as a substitute for boats.

Soil.

The fertility of the soil is various; but except in the rocky and mountainous places it is in general sufficient to afford an ample subsistence to the inhabitants. Nevertheless, they are sometimes visited by famine, resulting as much from the injuries of warfare as the effects of climate. Provisions are both cheap and plentiful. The horses reared on the banks of the river Beemah are highly esteemed, and constitute the best cavalry of the Mahrattas, who are eminently distinguished for that kind of military force.

Population.

The population of the province is calculated at 7,000,000; of which, about a twentieth part is supposed to consist of Mahometans; the great body follow the doctrines of Brahma. They affect observance of their religious customs in the utmost purity; they totally abstain from animal food, and some of them even scruple to subsist on roots. But they are said, notwithstanding, to be rather in disrepute among their own tribes in different parts of India. It is undoubted, however, that there are some devotees in the peninsula, who, far from crediting that all things are created for the use of mankind, reject every species of subsistence but

VOL. II. PART I.

Bejapour. milk, that nothing more gross may form in their intestines. Cows, it is well known, are objects of veneration, and in some places, beef is never used except by certain lower tribes of Hindoos; but particular towns have the privilege of killing beef for sale. Religious prejudices are carried to such an extraordinary height in India, that the lowest ranks of those sects which pique themselves on purity, would refuse to eat with sovereigns whom they did not esteem of an origin equally pure. Widows in Bejapour burn themselves with the bodies of their husbands, and a year never elapses without witnessing some of these horrible sacrifices; the offspring of the most barbarous principles of delusion. Bramins are found in this territory weak enough to maintain, that the ground they occupy is so sacred that it will bear only a particular species of shrub, which, in the fervour of their zeal, they have consecrated. It is likely that the Mahometan religion was much more in observance formerly than at the present date, from the number of mosques seen in various stages of decay.

There are many large towns and celebrated cities in this province, which was once a great and independent kingdom. Of these, the principal are Bejapour, Poonah, Satarah, Hubely, Huttany, Punderpoor, Darwar, and Meritch, for the most part populous and wealthy places. Bejapour is a city of such immense extent, that, were we not in possession of recent observations, what has been said regarding it might be supposed altogether fabulous. It is situated on a fine plain, in a fertile country, and now rather resembles the ruins of several separate and detached towns, than the remains of a single city. Its name, in the native language, signifies *impregnable*; and it may be said to consist of three cities contained within each other. The exterior is encompassed by a wall many miles in circuit, fortified by capacious towers of hewn stone, at intervals of 100 yards, and secured by a ditch and rampart. The interior, or second city, which is the fort, is not less than eight miles in compass; and the third or innermost, contained in it, is the citadel or strong-hold, which is a mile in circumference. But the whole are approaching to a state of decay, although the massy materials of which they are composed will long resist the ravages of time. The natives affirm, that, when the city was in its full splendour, it contained, according to authentic records, 984,456 houses, and 1600 mosques or temples. How far the former number is exaggerated we have no means of determining; the latest visitors are of opinion that the number of mosques and temples may have been as stated. Without supporting the affirmation of the natives, we may observe, that some great cities of the east are, in fact, an assemblage of towns and villages encompassed by a common wall, and even include gardens and cultivated fields. Besides, with regard to Bejapour, we learn, that, in the year 1689, when invested by Aurungzebe at the head of his army, 15,000 cavalry could encamp between the fort and the city wall. A mile and a half distant from this, a town, called Toorvee, has been built from part of the remains of the city, amidst magnificent piles of ruins.

The fort is approached from one side, through a

11

Bejapour. neat small town on the south-west. The ditch, originally a formidable obstacle, is excavated from the rock on which it stands. The curtain or wall is of great height, probably 40 feet, entirely composed of huge stones, strongly cemented together, and frequently ornamented with sculptures of lions and tigers. It is flanked by numerous great towers, built of similar materials, and some with ornaments resembling a cornice at the top. The fort has seven entrances, five of which are in use, and the other two are shut. On the south-west side it is entered by three gates, near to the innermost of which is a tank, or artificial pond, about 300 feet long, by 225 broad, environed by steps descending to the water, and surrounded by an inclosure of fine stone houses, through which it is reached by an arched passage 50 feet wide. Several distinct towns are contained within that part called the fort, with neat bazars or market-places; and there are many splendid edifices, on which all the embellishments of eastern taste and magnificence have been lavished.

Among the first which claims admiration, is a great mosque, commenced by Mahomet Adil Shah, king of Bejapour, who died in the year 1660, and continued by his successors. The main body extends 291 feet by 195, and there is a wing projecting from each end 219 feet long by 45 broad, inclosing together, with the main body, a large reservoir and a fountain. Five lofty arches spread along the whole extent of the eastern front, under the centre of which are a few steps leading up into the building. The interior is richly ornamented with passages from the Koran, with the names of God, Mahomet, or the Caliphs, in relief; the groundwork enamelled, and the letters polished or gilt. In a mausoleum, 153 feet square, the body of the Shah reposes. There are circular buildings on the external angles, which, as well as the wall, rise about 100 feet high. Its grand entrance is very lofty, and highly adorned with sculptured inscriptions, and other ornaments. This sepulchral chamber is surmounted by a great dome, whose internal diameter is 117 feet, a vault under the centre of which contains the royal remains. But the dome is much neglected, and shrubs and weeds find root in it, which must occasion premature decay. The whole is executed in a style of plain and simple grandeur.

Without the fort, in the exterior city, there is a mosque of still larger dimensions, and the mausoleum of Ibrahim, another king of Bejapour, who seems to have completed it about the year 1620. The mosque is 390 feet in length, by 156 in breadth. Fronting it, at the distance of 40 yards, is the mausoleum, 57 feet square, inclosed by two virandas, the inner 13 feet broad and 22 feet high, the outer 20 feet broad by 30 in height, supported by seven arches in each face, which are beautifully ornamented above. The sides of the chamber are sculptured in the most elaborate manner with flowers on a blue ground resembling enamel, and sacred passages, as before, in relief, cut out of a black stone, and polished as highly as a mirror. The doors are studded with gilt knobs, and the doorways are adorned with a variety of ornaments exquisitely executed. Around the southern entrance,

there is a mystical tetrastich, signifying that the cost of the edifice was equivalent to L. 700,000, and it is said that 6533 workmen were employed on it 36 years, 11 months, and 11 days. Six graves are inclosed by the sepulchral chamber, which are always covered with a fine white cloth. Above it is a cupola: and the mosque is surmounted by another immense dome, supported on arches. The whole edifice is finished with a profusion of ornaments in the highest style of embellishment. There is also in Bejapour the tomb of Aurungzebe's queen, who was mother of his favourite son, consisting simply of beautiful white marble.

This city, as we have already seen, is equally distinguished by its fortifications. Indeed, everything here appears on a gigantic scale; and among the most remarkable objects, may be enumerated some enormous cannon, said to be twelve in number, deposited in different places. Many more were originally employed in its defence. Three of these are particularly described; the first, contained in a great tower on the south-east side of the fort, is a Malabar gun composed of iron bars hooped together, and hammered smooth; its dimensions are as follows:

Length,	-	-	21 Feet	5 Inches.
Diameter at the breech,	4		5	
Diameter at the muzzle,	4		3	
Calibre,	-	-	1	9

The second gun, which is of the same construction, and called in the language of the country the *Flyer*, is contained in a lofty tower near the western side of the fort; its dimensions are,

Length,	-	-	30 Feet	3½ Inches.
Circumference at the breech,	-	-	9	2
Circumference at the muzzle,	-	-	7	7
Calibre,	-	-	1	1

But the third is of brass, and fixed on a great iron ring inserted in the ground, and grasping its trunnions, in the manner of a swivel. It is contained in a tower still larger than the former, on another side of the fort, and its dimensions are not inferior, though in none of the modern proportions;

Length,	-	-	14 Feet	1 Inch.
Diameter at the breech,	4		10½	
Diameter at the muzzle,	4		8	
Circumference in the middle,	-	-	13	7
Calibre,	-	-	2	4

This enormous gun is called *Moolk e Meidan*, or the *Sovereign of the Plains*, and it would carry an iron shot of 2646 lbs. It is beautifully wrought with several ornamental devices, particularly about the muzzle, and its polish is almost equal to that of glass. Several Persian and Arabic inscriptions appear upon it in elegant characters, one of them, according to English travellers, purporting that it was cast by Aurungzebe, the famous Mogul emperor, on his conquest of

Bejapour. the city in 1689; but we observe that some eastern historians affirm that he only substituted this inscription on erasing a previous one, and that during the siege of Bejapour, the shot of *Moolk e Meidan* damaged the mosque and mausoleum of Ibrahim Adil Shah. This gun had a companion of equal size, called *Kurk e Bedjlee*, or *Thunder and Lightning*, which was carried to Poonah, and is supposed to have been melted down. Probably no European cannon of equal size are known; *Mons-Meg*, a celebrated gun, now in the Tower of London, whither it was removed from Edinburgh Castle, is only of 20 inches calibre, and tapers downwards.

The inner fort or citadel, though a mile in circuit, is compared to a speck in the space occupied by the outer one. It is a place of great strength, consisting of a curtain, frequent large towers, a ditch, and covert way; the whole composed of massy materials, well constructed. The ditch, which was formerly supplied with water, is in most parts 100 yards wide, but the rubbish now filling it precludes any calculation of its original depth. The citadel itself is gained through several gates; but within it is a heap of ruins; and only one edifice, a beautiful small mosque, is in complete repair. Here were the palaces of the kings; the front of one of which is formed of three arches; that in the middle 87 feet wide. It has been observed, that all the arches in the city of Bejapour are Gothic, except those in the remains of a fine black stone palace in the citadel, built by Ibrahim Shah, where they are elliptic.

These are only a few of the public edifices contained in this extensive place, situated amidst piles of ruins, which appear at the interval of miles. A minute and accurate traveller has remarked, "that none of the buildings here described, the palaces in the fort excepted, have in them any wood; they are in general constructed of the most massy stone, in so durable a style, that one is almost induced to suppose, that the rudest hand of time, unaided, could scarcely have effected such destruction, nor could it seem that such ponderous gates were reared by the hands of men. The massy materials of some, the minute exquisite workmanship, and still greater durability of others, the ingenuity of the projectors, the skill of the artists, everything, indeed, that adorns the science of architecture are here united in so many instances, that the mind can scarcely realize the grandeur and magnificence of the objects that are in every direction scattered so profusely. On the other hand, such mountains of destruction, noble even in ruins, dictate the idea, that it proceeded, not from the ordinary revolution of time and things, but that they were rent from their foundation by some violent convulsion of nature." Until very lately, the most inaccurate opinions prevailed in Europe regarding the site and extent of Bejapour, which was better known by the name of Visiapour.

Poonah. Poonah, the capital of the formidable empire of the Mahrattas, also stands in this province; at a place where the rivers Moota and Moola meet, and form a united stream called Moota-moola. Unlike the former, it is an open and defenceless city, occupying a superficial area of about two miles

square, and washed on the north by the river Moota; there about 600 feet wide, but shallow in the dry season. A bridge across it was commenced some time ago by the Peshwa, or Mahratta chief; but the decease both of himself and his successor having followed, the undertaking was abandoned as displeasing to the gods. The streets here are named after mythological personages venerated by the Hindoos, adding the termination *warry* to their proper appellation; and the divinities, with their monstrous and grotesque appendages, are sometimes painted on the exterior of the houses. There is an ancient castle in Poonah, surrounded by lofty strong walls, with only one entrance, and protected by four round towers, wherein some members of the Peshwa's family reside; but he occupies another residence, and, not long since, he had directed a palace to be erected by British architects. The population of Poonah is estimated at 100,000 souls. Formerly, the Mahrattas, on invasion of a hostile force, did not consider the preservation of so defenceless a place of importance to their power, and they have themselves destroyed it, retiring to Pootunder, a fortress on a mountain, about 18 miles distant, where the archives are deposited, and where some of the principal officers usually reside. Its prosperity is said to have been retarded by great assemblages of people who convoke for the purpose of celebrating some religious festivals, and marking their retreat, when these are over, by indiscriminate pillage and depredation. Poonah is 98 miles from Bombay.

Punderpour is a flourishing and populous city, 86 Punder-miles south-east of Poonah, situate in a fertile and ^{pour.} pleasant country, on the river Beemah, by which it is sometimes inundated. Though not of great extent, it is regularly and well built; the streets are broad, paved, and adorned with many handsome houses, the first storey consisting of stone, and the second of red brick, which has a very agreeable effect. The Peshwa and most of the principal members of the Mahratta government have elegant mansions in Punderpour, whither they retire as a relaxation from the fatigues of business. Besides native products, many articles of European manufacture are to be obtained here, as the merchants have connections with those of Bombay.

Among other towns in the province of Bejapour, Hubely and there are two of considerable size, called Hubely ^{Huttany.} and Huttany. The appearance of the former, which is situate in a district well wooded and watered, and in a high state of cultivation, bespeaks industry and comfort. An extensive inland traffic is carried on by its inhabitants, and a commercial intercourse is conducted with the east, principally through the medium of Goa, whence, in return for sandal-wood and elephants' teeth, they receive raw silk, cotton, and woollen stuffs. The bankers, who are rich and numerous, extend their transactions to Hyderabad, Seringapatam, and Surat: and the markets are so well attended, that the streets are scarcely passable from the crowd. There are two forts here, now very defenceless, from nearly being environed by houses; but the town has frequently been an object of competition between contending

Bejapour. powers. Huttany is inclosed by a wall and ditch, and also has a fort, which is incapable of standing a siege. In the year 1679, it was taken from the Mahrattas, and the enemy proposed to sell all the inhabitants for slaves; but this was not carried into execution. It is now large and populous, carrying on a great manufacture of silk and cotton; and an extensive trade in these articles, and also in grain, with the north of India and elsewhere. The natives are celebrated for their courtesy to strangers, whom they apparently are desirous of impressing with a high opinion of their wealth.

There are many strong forts in the province, smaller, and thence more capable of protracted resistance, than those already named. Such is Darwar, or Haserabad, a place of great strength, inclosed by a wall and ditch. In the year 1790, it was besieged by the united forces of the British and Mahrattas, amounting to 40,000 men, and surrendered by capitulation, chiefly from scarcity of provisions. This fort stands in a territory called Darwar, which is particularly subject to whirlwinds, advancing in the figure of an immense column, with irregular motion, great noise, and considerable rapidity. Clouds of dust are carried up by the column, which is 20 or 30 feet in diameter at the base, to a greater height than the eye can reach. Sometimes tents are beat down in its progress; and the only dress of their inmates swept half a mile away, while a close pursuit is necessary to recover it. Satarah, a strong hill fort and tower, stands at the summit of a declivity ascending several miles, distant 16 leagues from Poonah. Its name, according to some, signifies a star, being the form in which it is built; or, according to others, 17 walls, 17 towers, and 17 gates, with which it is said to be provided. It is accessible only by a very narrow path, admitting a single person at a time. In the year 1651, it was taken from the sovereign of Bejapour by the founder of the Mahratta empire; and here the descendant of the captor is still imprisoned. It should be understood that the Peshwa who is invested with the real authority, is only the representative of the head of the Mahrattas, while the sovereign enjoys nothing but nominal power, and is kept in a situation of restraint. But the Peshwa must nevertheless be invested in office by him, and he receives some external demonstrations of authority, though deprived of liberty, and is otherwise slenderly provided for.

History of this Province.

Bejapour is therefore a populous and flourishing province, and one which, with its capital, has held a distinguished place in history. Four-fifths of it pertain to the Mahrattas; the remainder to the Nizam. It formerly constituted an independent sovereignty, with the antiquity of which we are not acquainted, farther than that Abou al Muzuffir Eusuff Adil Shah was the founder of the Adil Shavee, one of the principal dynasties. The father of this prince, dying in the year 1450, his brother, to obviate all disputes about succession to the kingdom, directed that he should be put to death; but the Sultana his mother, having prevailed on the executioners appointed by this barbarous order to spare her innocent child a single day,

Bejapour. studied to devise the means of his preservation. She sent immediately for Khajeh Ummed ud Dien, a merchant accustomed to supply her household, inquiring how many slaves he had for sale; and finding he had five Georgian and two Circassian boys, selected one of the latter who bore the greatest resemblance to her own son. He was strangled, and brought out in a shroud, without any suspicion being excited of the deception. The Sultana then induced the merchant to hasten with the young prince to a secure retreat, out of the Mahometan dominions; and he repaired with his charge to a town in Persia. There the prince attained many accomplishments, and remained until reaching the age of eighteen, when he resolved to revisit Hindostan. He soon obtained an important appointment in one of the courts of that country; and, by a series of good fortune, ascended the throne of Bejapour in the year 1489. His reign was long and prosperous; he patronised learning; encouraged the residence of foreign artists; the kingdom flourished; and his death was deeply regretted as a misfortune by his subjects. The fourth in succession from this prince was Ibrahim Adil Shah, who, attacked by a complication of disorders, put to death the physicians unable to effect his cure; decapitating some, and trampling others under the feet of elephants, which excited such an alarm, that all the survivors fled beyond his boundaries. In the year 1665, the governor of the Deccan was directed to render himself master of Bejapour. The natives were defeated, though they had an army of 80,000 horse, their general was killed, and the survivors pursued within ten miles of the capital. Aurungzebe renewed his invasion in 1668, and besieged the city in person; but the inhabitants defended themselves with great resolution. The country had been laid waste, supplies were intercepted, and so great a body of people confined in a restricted space began to be distressed for provisions. Meantime, the hostile batteries having effected sufficient breaches, preparations were made for an assault; but the inhabitants, apprehensive of the issue, resolved to capitulate, and the king surrendered himself to the Mogul emperor, by whom he was treated honourably; for one of his sisters had been married to a son of Aurungzebe; and his principal officers received marks of distinction. Aurungzebe entered the fort through the breach by which the assault was to have been made, and, repairing to the great mosque, already damaged by his cannon, offered up a thanksgiving for his success. But the internal tranquillity of Bejapour had been previously weakened by the revolt of Sevajee, the founder of the empire of the Mahrattas. They did not view the invasion of the Mogul emperor without jealousy; and, as their own power was constantly augmenting after his decease in 1707, they gradually compelled his successors to withdraw. Descending to a later period, we find that they had been unable to reduce the country to order and quietness; and, after a keen contest between them and the British, which terminated in the year 1804, their whole territory was in a state of anarchy. The authority of the Peshwa was either resisted or denied, and scarcely extend-

Bejourn
Bell Rock.

ed beyond his capital, Poonah. The country was occupied by lawless depredators, and all the subordinate chiefs were rebellious and dissatisfied. It was found expedient for the British government to interpose, and endeavour to restore tranquillity,—a laudable measure, which was in a principal degree effected by the prudence and moderation of Sir Arthur Wellesley, now Duke of Wellington. He preserved many of the chiefs from the vengeance which their leader had resolved to take upon them, and induced them to recognise his authority, in paying the service due. Nevertheless, it is easy to anticipate, that, if their union is preserved, they will steadily resist the approaches of foreign nations towards their territory, and most probably will prove a material obstacle to the further aggrandizement of the British in Hindostan. (s.)

BELL ROCK LIGHT-HOUSE. The accompanying Plate (XXXIII.) exhibits a perspective view of this important national edifice (which has not improperly been termed the *Scottish Pharos*), as it is seen after a gale at north-east. In describing it we shall first notice the position of the rock, and circumstances connected with it, and then describe the progressive advancement and finishing of the building.

Description
of the Bell
Rock.

The *Inch Cape*, or Bell Rock, is situate on the north-eastern coast of Great Britain, about 12 miles in a south-western direction from the town of Arbroath, in the county of Forfar, and about 30 miles in a north-eastern direction from St Abb's Head, in the county of Berwick; and, as may be seen from the charts of that coast, it lies in the direct track of the Firth of Tay, and of a great proportion of the shipping of the Firth of Forth which embraces the extensive local trade of the populous counties of Fife, Clackmannan, Stirling, Linlithgow, Edinburgh, and Haddington; and which being an admiral's station, is now the rendezvous of the North Sea fleet. This estuary is, besides, the principal inlet upon the eastern coast of Britain, in which the shipping of the German Ocean and North Sea take refuge, when overtaken by easterly storms. When the tides are neap, or at the quadratures of the moon, the Bell Rock is scarcely uncovered at low water; but, in spring tides, when the ebbs are greatest, that part of the rock which is exposed to view at low water measures about 427 feet in length, by 230 feet in breadth; and, in this low state of the tides, its average perpendicular height above the surface of the sea may be stated at about four feet. Beyond the space included in these measurements, at very low tides, there is a reef on which the larger kinds of fuci appear floating at the surface of the water. This reef extends about 1000 feet, in a south-western direction from the higher part of the rock just described, on which the light-house is erected. The whole rock is composed of sandstone of a red colour, with some spots of a whitish colour. It strongly resembles the rocks forming the promontory on the Forfarshire coast, called the Red Head, and those also of the opposite shores of Haddington and Berwick shires, near Dunglass. The stone is hard, of a fine grain, and contains minute specks of mica. Its surface is rugged, with holes which, at ebb-tide, form small pools of water. Such parts of

Bell Rock.

the rock as appear only in the lowest tides, are thickly coated with fuci; the larger specimens are *Fucus digitatus*, *great tangle*, and *Fucus esculentus*, or *badderlock*, a sea-weed which sometimes attains here the length of 18 or 20 feet. Those parts most frequently left by the tide are covered with small shell-fish, such as the common barnacle, the limpet, the whelk, and a few common muscles; and some very large seals rest upon its extremities at low water of spring-tides. At high water, the red ware cod is caught over the rock; and at a distance from it, as the water deepens, the common cod, haddock, whiting, skate, holibut, and other fishes common in these seas, are very numerous.

Such being the position and nature of the Bell Rock, lying in the direct track of a numerous class of shipping, and appearing only a few feet in height above the water, and that only at the ebbs of spring-tides, being at high-water wholly covered to the depth of from 10 to 12 feet; the want of some distinguishing mark that might point out its place was long felt by the mariner, and of the utility and necessity of this, every returning winter gave the public fresh proofs. But it required a great extent of commerce to afford the probability of raising an adequate revenue, by a small duty or tonnage upon vessels passing it, to meet the risk and expence of such a work, as the erection of a habitable house about 12 miles distant from the nearest land, and on a rock from 10 to 12 feet wholly under water at spring-tides. We have read of the wonderful extent of the Pharos of Alexandria, and are acquainted with the Tower of Corduan, erected upon a small island at the entrance of the Garonne, on the coast of France, and know, more particularly, the history and structure of the Eddystone light-house, built upon a small rock lying 12 miles off the coast of Cornwall. The public is in possession of Mr Smeaton's perspicuous and valuable account of that work; but it is to be observed, that, in the erection of a light-house upon the Bell Rock, independently of its distance from the main-land, a serious difficulty must here have presented itself, arising from the greater depth of water at which it was necessary to carry on the operations, than in the case of any former building of this kind.

Dangerous
position of
the Rock.

Tradition tells us, that so far back as the fourteenth century, the monks of Aberbrothick caused a large bell to be suspended, by some means or other, upon the Rock, to which the waves of the sea gave motion, the tolling of the bell warning the mariner of his approaching danger. From this circumstance it is said the Rock got its present name, but in so far as can now be discovered, there is no record of this contrivance; and it seems more probable that, at an early period before the wasting effects of the sea had brought the Rock into a state so low and mutilated, some part of it may have resembled a bell in appearance, and have thus given rise to the name.

Although the dangers and the inconveniences of this Rock, and of the coast in general, were long and severely felt by the shipping of the eastern coast of Great Britain; yet, till of late, there was no constituted body for the erection of light-houses in

Preparatory
Measures.

Bell Rock. Scotland; such an appointment necessarily supposes a more extensive trade than that part of the united kingdom possessed prior to the union of England and Scotland; and even long after that happy event, the finances of the country were not in a state to warrant expensive undertakings of this nature. About the middle of the last century, however, when the improvement of the highlands and islands of Scotland was viewed as an object of great national importance, the establishment of light-houses upon that coast was found indispensably necessary to the extension and success of the British Fisheries. This subject was accordingly agitated in the Convention of the Royal Burghs of Scotland; and, in the year 1786, a bill was brought into Parliament, appointing the Lord Advocate and Solicitor-General of Scotland, the Sheriff-depute of the maritime counties, and the chief Magistrates of certain of the Royal Burghs, *ex officio*, to act under the title of the *Commissioners of the Northern Light-houses*; and a certain duty on tonnage upon shipping was granted to them, for the erection and maintenance of such light-houses as they should find necessary to erect upon the coast of Scotland. But when a sufficient number of Light-houses are erected upon the coast, and a fund accumulated for their maintenance, the act provides, that the light-house duties shall cease and determine. These Commissioners, in virtue of the powers vested in them, proceeded to the immediate improvement of such accessible points of the coast as suited the infant state of their funds; and, in the course of a few years, eight of the principal headlands between the Firths of Forth and Clyde, including the Orkney Islands, were provided with light-houses, erected upon the most approved principles of the time, by the late Mr Smith, engineer for the Light-house Board. Keeping always in view as a principal object the erection of a light-house on the Bell Rock, the Commissioners, independently of these highly useful and important works, were gradually accumulating a fund for this purpose, in order to undertake that work as soon as their limited means would admit. In the month of December 1799, the occurrence of a dreadful storm rather tended to hasten this measure. The wind for two days was excessive, and being from the south-eastern direction, all the ships were driven from their moorings in the Downs and Yarmouth Roads. No fewer than about 70 vessels were wrecked, and with many of their crews were totally lost, upon the eastern coast of Scotland; a calamity that more especially directed the attention of the country and of the Commissioners, to the erection of a light-house upon this Rock; as, in this particular instance, a light-house there would have opened the Firth of Forth, as a place of safety to many, which, to avoid the hidden dangers of the Rock, were lost in attempting to get to the northward of the Firth in this storm.

After the loss of so many lives, and much valuable property, various measures were taken for the erection of a light-house upon this Rock. In the year 1803, a bill was brought into Parliament, which, with some alterations, ultimately pass-

ed both Houses, in the session of 1806; by which the northern light duty of three halfpence *per ton* on British vessels, and threepence *per ton* on foreign bottoms, was extended to all vessels sailing to or from any port between Peterhead to the north, and Berwick-upon-Tweed to the southward. This bill also empowered the commissioners to borrow L. 25,000 from the *three per cent. consols*, and having already accumulated the sum of L. 20,000 of surplus duties, with this loan from Government they were enabled to commence the operations at the Bell Rock with a disposable fund of L. 45,000.

Several plans for the erection of this light-house had for a considerable time been in contemplation, and were submitted for consideration of the Light-House Commissioners. Captain Brodie of the Navy constructed a very ingenious model of a cast-iron light-house to stand upon pillars; and Mr Murdoch Downie, author of several marine surveys, brought forward a plan of a light-house, to stand upon *pillars of stone*. Mr Telford, the engineer, was likewise employed in some preliminary steps, connected with Mr Downie's inquiries. In the year 1800, Mr Stevenson, engineer for the Commissioners of the Northern Light-houses, modelled a design applicable to this situation; and having, by their directions, made a survey and report relative to the situation of the Bell Rock, which was published by the Board, along with a letter from Admiral Sir Alexander Cochrane, when he commanded his Majesty's ship *Hynd*, upon the Leith station, in 1793, recommending the erection of a light-house on this Rock; these, with other documents, were afterwards submitted to Parliament, in a memorial from the Commissioners, drawn up by Robert Hamilton, Esq. advocate, one of their number; when application was made for a loan from Government. So different, however, were the views taken of the subject, and so various and doubtful were the opinions of the public about the kind and description of building best suited to the peculiar situation of the Rock, and even with regard to the practicability of a work so much under the surface of the water, and where so large a sum of money was necessarily to be expended, that the Commissioners thought it advisable to submit the matter to the opinion and advice of Mr Rennie. This eminent engineer coincided with Mr Stevenson in preferring a building of stone upon the principles of the Eddystone light-house, which being approved of and adopted, the execution of the work was finally committed to these gentlemen.

The bill having passed late in the session of 1806, in the following summer a vessel was fitted out as a floating-light, for which the act of Parliament made provision, and she was accordingly moored off the Bell Rock in the month of July 1807. During the first season of the operations, this vessel was used as a *Tender*, to which the artificers retired while the Rock was covered with water. Her station was about a mile and a half north-east from the Bell Rock, and her moorings consisted of a *mushroom anchor*, weighing 33 cwt. and a weighty chain laid down in 22 fathoms water, and at these moorings she rode by

Bell Rock. a strong hempen cable, measuring 14 inches in circumference, without accident, during the four years in which the light-house was building. This vessel was rigged with three masts, each of which carried a lantern, which, in a curious manner, was made to embrace the masts; and, by this means, the use of cumbrous yards and spars over head were avoided; and as each mast passed through the centre of its respective lantern, on which it traversed, the light was not obscured on any side. Each of these lanterns contained ten lamps, with as many small silver-plated reflectors; and thus, by the appearance of three distinct lights (the centre one being the highest), the Bell Rock floating-light formed a triangular light, and was easily distinguishable from the double and single lights upon the coast, and rendered immediate and essential service to the trade and shipping of the coast.

retard their progress, and by the latter end of October, the beacon, consisting of twelve large beams of fir-timber, was erected, having a common base of 30 feet, and rising to the height of 50 feet above the surface of the Rock. These spars were of fir-timber, strongly framed with oak-knees, connected to the Rock with iron-bats of a particular construction, set into holes, cut about 18 inches in depth, and wedged into their places, first with slips of fir, then with slips of oak, and, lastly, with pieces of iron. The upper part of this beacon was afterwards fitted up, and occupied as a place of residence during the working months. The lower floor was employed as a smith's forge, and also for preparing mortar for the building. The cook-house was immediately over this; the next floor was occupied by the cabins of the engineer and foremen, and over all was the barracks for the artificers, whose hammocks were ranged in tiers of five in height. The dwelling or lodging part of this temporary residence was above the reach of the sea in moderate weather, but the lower floor was often lifted by the waves, when the lime casks, and even the smith's anvil and apparatus, were frequently washed away. The beacon-house, so constructed, was erected near the site of the light-house, and in the more advanced state of the work, was connected with it by a wooden bridge; which was also of the greatest utility as a stage in raising the materials from the Rock to the building. A little reflection upon the singular position and circumstances of the Bell Rock, will show the great and indispensable use of this beacon-house in facilitating the operations. Unless some expedient of this kind had been resorted to at a work so much under water, the possibility of erecting a light-house here is extremely doubtful: at any rate, it must have required a much longer period for its accomplishment, and, in all probability, many lives would have been lost in the progress of the operations.

Bell Rock.

Operations of 1807.

Early in the spring of 1807, stones were collected from the granite quarries of Rubeslaw in Aberdeenshire, for the outside casing of the first 30 feet, or lower part of the building; those of sandstone for the hearting, or interior of the solid, and also for the higher parts of the building, were got from Mylnefield quarry, near Dundee. For the conveniency of the work, the cornice and parapet-wall of the light-room were hewn and prepared at Edinburgh, and the stones for these parts were accordingly taken from the quarry of Craigleith. At Arbroath, the most contiguous harbour to the Bell Rock, a piece of ground for a work-yard was procured on a lease of seven years, the supposed period for the duration of the works; and here the works were conducted; materials were laid down, and workmen collected; shades were also constructed, and a barrack erected for the accommodation of about 100 artificers when they landed from the Rock, that they might be at a call, by night or day, when required to sail for the works at the Rock. These previous steps being taken ashore, the operations at the Rock itself commenced in the month of August 1807.

Wooden Beacon-House.

The first attention at the Bell Rock was to erect a place of refuge for the artificers, in the event of an accident befalling any of the attending-boats,—a circumstance which, if unprovided for, might not only involve the safety of every person employed at the out-works, but prove a serious check to the future progress of the undertaking, which could only be proceeded in at low water of spring-tides, when two and a half or three hours were considered a good tide's work. From this circumstance, it became necessary to embrace every opportunity of favourable weather, as well in the day tides as under night by torch-light, and upon Sundays. In the early stages of the business, the flood-tide no sooner began to cover the exterior parts of the Rock, than the workmen were obliged to collect their tools and apparatus, and betake themselves to the attending-boats, before the water burst in upon them. These boats were rowed often with the utmost fatigue and difficulty to the floating-light, where the workmen remained till the Rock began to make its appearance again at next ebb-tide. Happily no accident occurred during this perilous part of the work, to check the ardour of the artificers, nor to

The circumstance of the beams of the beacon having withstood the storms of winter, inspired new confidence in the artificers, who now landed upon the Rock in the summer of 1808 with freedom, and remained upon it without fear till the tide flowed over it. Although it required a considerable part of the summer to fit up the beacon as a barrack, yet it was in a state sufficient to preserve the workmen in case of accident to the boats. The great personal risk and excessive fatigue of rowing boats, crowded with the artificers, every tide to the floating light-vessel was now also avoided by an additional vessel having this season been provided, and entirely set apart for the purpose of attending the Rock. This vessel was a very fine schooner of 80 tons. Her moorings were so constructed, that she could be cast loose at pleasure, and brought to the lee-side of the Rock, where she might at once take up the artificers and their boats in bad weather, instead of their having, as formerly, to row often against both wind and tide, to the more distant position of the floating light. From this circumstance, it was now found practicable both to commence the works at the Rock much earlier, and to continue them to a later period. Being now provided with a place of safety, by the erection of the spars of the beacon-house, and having a

Second Season's Operations of 1808.

Bell Rock. tender always at command, which could be cast loose, in case of need, the works now went forward even in pretty rough weather; and thus struggling both during the night and day tides, the site of the light-house was prepared, and cut to a sufficient depth into the Rock; and on the 10th of July 1808, the foundation stone of the building was laid. In the course of this season, tracks of cast-iron railways were also fixed upon the Rock, from the different landing places to the building, calculated for conveying blocks of stone of two or three tons weight along the Rock; and by the latter end of the season's operations the first four courses of the Light-house were built, which brought it to the height of five feet six inches above the foundation.

Third Season's Operations, 1809. In the course of the winter preceding the third season's operations, the works at the Rock were frequently visited, and, in the spring of the year 1809, were resumed with new vigour; and it was no small happiness to find, that not only the four courses of the light-house built last season were in perfect order, after a long and severe winter, without the least shift or change of position, but that even the beacon-house and railways were little injured, being almost in a state of readiness for resuming the operations. The first thing to be done was to lay down sets of chain moorings, with floating buoys for the tender, and for the flush-decked praam-boat, stone lighters, and vessels employed at the Rock, and to erect the necessary apparatus and machinery for landing the stones, and laying them in their places upon the building. These arrangements being made, every thing went forward in the most prosperous manner; and, by the month of September, the building was got to the height of 30 feet, which completed the solid part of the light-house. After obtaining this height, from the advanced state of the season, Mr Stevenson did not find it advisable to risk the machinery and apparatus longer, and the building was left in this state for the winter months.

Fourth Season's Operations, 1810. At the commencement of the fourth and last season's work, it was a matter of some importance for the preparation of the higher or finishing parts of the building, to ascertain whether it would be possible to carry the masonry from the height of 30 feet to 100 feet in the course of this summer; but it was extremely doubtful whether this could be accomplished, so as to secure good weather for fitting up the light-room, and completing the more delicate operations of the painter and glazier, connected with it. Under these uncertain prospects, the work was begun in 1810, at as early a period as the weather would at all admit. From the great number of finished courses of prepared stone at the work-yard, which had been tried upon the platform, numbered and ready to be shipped from Arbroath for the Rock, there was only the winds and tides to contend with; and even these were, in effect, wonderfully softened and allayed, by the enterprising exertions and thorough practice of the seamen and artificers, during four successive seasons; which had given much dexterity to the several departments, both in the work-yard at Arbroath, and at the Rock, where the operations of the builder and of the landing-master's crew were conducted with much skill and activity.

Bell Rock. Taking these mainly into account, and by a fortunate train of circumstances, the masonry of the building was completed in October; and the light-room being finished in the month of December, the light was advertised to the public, and exhibited for the first time from the new Light-house on the evening of the 1st of February 1811; and, on the same night, the floating light-vessel was unmoored, and that temporary light discontinued.

Description of the Light-house. Having thus given a general account of the Bell Rock, and the erection of the Light-house, we shall now describe the building, noticing its principal dimensions, and making such farther remarks as may appear interesting to the reader. The Bell Rock Light-house is a circular building, the foundation-stone of which is nearly on a level with the surface of the sea at low-water of ordinary spring-tides; and consequently at high-water of these tides, the building is immersed to the height of about 15 feet. The two first or lower courses of the masonry are imbedded or sunk into the rock, and the stones of all the courses are curiously dovetailed and joined with each other, forming one connected mass from the centre to the circumference. The successive courses of the work are also attached to each other by joggles of stone; and, to prevent the stones from being lifted up by the force of the sea, while the work was in progress, each stone of the solid part of the building had two holes bored through it, entering six inches into the course immediately below, into which oaken tree-nails, two inches in diameter, were driven, after Mr Smeaton's plan at the Eddystone Light-house. The cement used at the Bell Rock, like that of the Eddystone, was a mixture of pozzolano, earth, lime, and sand, in equal parts, by measure. The building is of a circular form, composed of stones of the weight of from two tons to half a ton each. The ground course measures 42 feet in diameter, and the building diminishes, as may be observed from the plate of the light-house, as it rises to the top, where the parapet-wall of the light-room measures only 13 feet in diameter. The height of the masonry is 100 feet, but including the light-room, the total height is 115 feet. The building is solid from the ground course to the height of 30 feet, where the entry-door is situate, to which the ascent is by a kind of rope-ladder with wooden steps, hung out at ebb-tide, and taken into the building again when the water covers the Rock; but strangers to this sort of climbing are taken up in a kind of chair, by a small moveable crane projected from the door, from which a narrow passage leads to a stone stair-case 13 feet in height. Here the walls are seven feet in thickness, but they gradually diminish from the top of the stair-case, to the parapet-wall of the light-room, where they measure one foot in thickness. The upper half of the building may be described as divided into six apartments for the use of the light-keepers, and for containing light-house stores. The lower or first of these floors, formed by an inside scarsement of the walls at the top of the stair-case, is chiefly occupied with water tanks, fuel, and the other bulky articles; the second floor is for the oil cisterns, glass and other light-room stores; the third is occupied as a kitchen; the fourth is the bed-room,

Bell Rock. the fifth the *library* or strangers' room, and the upper apartment forms the light-room. The floors of the several apartments are of stone, and the communication from the one to the other, is made by means of wooden ladders, excepting in the light-room, where every article being fire proof, the steps are made of iron. There are two windows in each of the three lower apartments, but the upper rooms have each four windows. The casements of the windows are all double, and are glazed with plate-glass, having besides an outer storm-shutter, or *dead-light* of timber, to defend the glass from the waves and sprays of the sea. The parapet-wall of the light-room is six feet in height, and has a door which leads out to the balcony or walk formed by the cornice round the upper part of the building; which is surrounded by a cast-iron rail, curiously wrought like net-work. This rail rests upon batts of brass, and has a massive coping or top rail of the same metal.

Furniture of the House. In the kitchen, there is a kind of grate or open fire-place of cast-iron, with a smoke tube of the same metal which passes through the several apartments to the light-room, and heats them in its passage upwards. This grate and chimney merely touch the building, without being included or built into the walls, which, by this means, are neither weakened, nor liable to be injured by it. The timber of the doors, and the pannelled partitioning of the rooms from the stairs, and also of the bed frames and furniture in general, is of wainscot.

Light-room. The light-room and its apparatus was entirely framed and prepared at Edinburgh. It is of an octagonal figure, measuring 12 feet across, and 15 feet in height, formed with cast-iron sashes, or window frames glazed with large plates of polished glass, measuring about 2 feet 6 inches by 2 feet 3 inches, each plate being of the thickness of a quarter of an inch. The light-room is covered with a dome roof of copper, terminating in a large gilded ball, with a vent-hole in the top.

Description of the Light. The light of the Bell Rock is very powerful, and is readily seen at the distance of six or seven leagues, when the atmosphere is clear. The light is from oil, with Argand burners placed in the focus of silver-plated reflectors, measuring 24 inches over the lips; the silvered surface or face being hollowed or wrought to the parabolic curve. That the Bell Rock light may be easily distinguished from all other lights upon the coast, the reflectors are ranged upon a frame with four faces or sides, which, by a train of machinery, is made to revolve upon a perpendicular axis once in six minutes. Between the observer and the reflectors, on two opposite sides of the revolving frame, shades of red glass are interposed, in such a manner, that, during each entire revolution of the reflectors, two appearances, distinctly differing from each other, are produced; one is the common *bright light* familiar to every one, but, on the other, or shaded sides, the rays are tinged of a *red colour*. These red and bright lights, in the course of each revolution, alternate with intervals of darkness, which, in a very beautiful and simple manner, characterize this light.

As a farther warning to the mariner, in foggy

weather, two large bells, weighing about 12 cwt. are tolled day and night by the same train of machinery which moves the lights. As these bells, in moderate weather, may be heard considerably beyond the limits of the Rock, vessels, by this means, get warning to put about, and are thereby prevented from running upon the Rock in thick and hazy weather; a disaster to which ships might otherwise be liable, notwithstanding the erection of the light-house.

Prior to, or about the time of the erection of the Bell Rock light-house, it was by no means uncommon to meet with various doubts, regarding the practicability of the works, expressed in such terms as the following: "That, even if it were practicable to erect a light-house, upon such a sunken rock, no one would be found hardy enough to live in an abode so dread and dreary, and that it would fall to the lot of the projectors themselves to possess it for the first winter." But the reverse of all this took place; for the confidence of the public had been confirmed by the stability as well of the wooden-beacon-house, as of the building itself, which, in its progressive rise, withstood the storms of two successive winters, in an unfinished state; so that, by the time the house was ready for its inhabitants, the applications for the place of light-keepers were much more numerous than the situations; and applicants on both sides of the Tweed were disappointed in their wishes.

The establishment of light-keepers at the Bell Rock, consists of a principal light-keeper, who has at the rate of 60 guineas *per annum*, paid quarterly; a principal assistant, who has 55 guineas; and two other assistants at 50 guineas each; besides a suit of uniform clothes, in common with the other light-keepers of the Northern Light-houses, every three years. While at the rock, these men get a stated allowance of bread, beef, butter, oat-meal, pot-barley, and vegetables, besides small beer, and an allowance of fourpence *per day* each for the purchase of tea and other necessaries. At Arbroath, the most contiguous town on the opposite coast, a suite of buildings has been erected, where each light-keeper has three apartments for his family. Here the master and mate of the light-house tender have also accommodation for their families; a plot or piece of an inclosed garden ground is attached to each house, and likewise a seat in one of the pews in the parish church of Arbroath. Connected with these buildings, there is a signal tower erected, which is about 50 feet in height. At the top of it, there is a room with an excellent five feet achromatic telescope, placed upon a stand. From this tower, a set of corresponding signals is arranged, and kept up with the light-keepers at the rock. Three of the light-keepers are always at the light-house, while one is ashore on liberty, whose duty it is for the time to attend the signal room; and when the weather will admit of the regular removal of the light-keepers they are six weeks at the rock, and a fortnight ashore with their families.

The attending vessel for the Bell Rock, and the light-houses of the Isle of May and Inchkeith, in the Firth of Forth, is a very handsome little cutter of about 50 tons register, carrying upon her *proa* a

k k

Bell Rock
Beloochistan.

model of the Bell Rock light-house, and is appropriately named the *Pharos*. She is stationed at Arbroath, and is in readiness to proceed for the Rock at new and full moon, or at spring-tides, carrying necessaries, and the light-keeper on leave, to the Rock, and returning with another. This vessel is navigated by four men, including the master, and is calculated for carrying a boat of 16 feet keel, or of sufficient dimensions for landing at the Rock in moderate weather. The master and mate are kept in constant pay, and have apartments in the establishment ashore; the former, acting as a superintendent, has the charge of the buildings and stores kept at Arbroath.

Expence of
this Light-
house.

The expence of the Bell Rock light-house, and its establishment, in a general way, may be stated to have amounted to about L.60,000. The undertaking does much honour to the exertions of the Commissioners of the Northern Light-houses, and is even creditable to the age which has produced it; especially when it is remembered, that it was commenced and completed amidst the difficulties and demands of a war, unparalleled in the history of our country. (HH.)

Our readers will perceive, that the account we have given of this Edifice is, necessarily, of a very general nature; but the public, we believe, will soon be gratified with an ample *Historical Account of the Northern Light-houses*, including a full detail of the whole operations connected with the Bell Rock light-house, and the Carr Rock Stone-Beacon, illustrated with numerous plates, showing the progressive stages of these works, by Mr Stevenson; and we are happy to learn, that the Commissioners of the Northern Light-houses, from a conviction of the utility of the design, have, as a Board, liberally expressed their desire to promote the intended publication of Mr Stevenson, whose name, as an Engineer, is so creditably connected with these two important national undertakings.

Geographi-
cal Situa-
tion and
Boundaries.

BELOOCHISTAN, a country of Asia, situate on the north-west coast of the Indian peninsula. It is bounded on the north by Affghanistan and Seistan; on the west, by the Persian provinces of Kirman and Laristan; on the south, by the Indian Ocean; and, on the east, by a part of Sind and Shikarpoor. In general, it may be said to comprehend all that space within the 25th and 30th degrees of north latitude, and the 58th and 68th degrees of east longitude; and its whole superficial extent may be computed at 550 geographical miles in length, and 300 in breadth.

History.

Of the early history of this portion of the Asiatic Continent, little or nothing is known. The poverty and natural strength of the country, combined with the ferocious habits of the natives, seem to have equally repelled the friendly visits of inquisitive strangers, and the hostile incursions of invading armies. The Greeks, from whom we derive the earliest information relative to the western frontiers of India, are almost entirely silent with respect to this mountainous and inhospitable tract; and scarcely any notice of it occurs for many centuries posterior to the Macedonian invasion. Hence it is impossible to

Beloochistan.

trace the first settlement of this country; and the descent of its inhabitants can only be imperfectly ascertained by analogy and conjecture. As the natives have no written language, their historical annals are merely traditional, and therefore entitled to little credit. The Belooches ascribe their own origin to the earliest Mohummudan invaders of Peraia, and are very desirous of being supposed to be of Arabian extraction; but the latter part of this supposition derives no confirmation from their features, their manners, or their language, which do not bear the slightest similitude to those of the Arabs. There can be little doubt, however, that they originally came from the westward; of which there is strong evidence in the affinity between the Beloochee and Persian languages; and their institutions, habits, and religion, seem to indicate that they are of Toorkuman lineage. It seems highly probable, indeed, that, during the frequent sanguinary revolutions to which the monarchy of the Seljukide Tartars was subject, some of these barbarians had been forced to wander over the country in quest of new settlements; and that a portion of them had found refuge in the mountainous districts of Beloochistan. But, besides the Belooches, there are other distinct tribes of inhabitants in Beloochistan, whose peculiar habits and shades of character, we shall afterwards take an opportunity of describing. These are the Brahoos, apparently a race of Tartar mountaineers, who settled at an early period in the southern parts of Asia, but whose history is extremely obscure and uninteresting; the Dehwars, clearly a Persian colony, whose original settlement cannot be traced; and the Hindoos, who appear to have been the first settlers in the upper part of the Brahooick mountains, on their being expelled from Linde, Lus, and Mukran, by the armies of the Caliphs of Bagdad. This last tribe appears to have constituted the governing party, at the earliest period of which any thing approaching to authentic information has been obtained. The Brahoos and Belooches, however, gradually spread over the country; and the Hindoo power was at length subverted by a revolution, which placed the ancestors of the present Khan of Kelat upon the throne.

The precise period at which this revolution took place, cannot be accurately ascertained; but it is probable that two centuries have not elapsed since that event. The last rajah of the Hindoo dynasty found himself compelled to call for the assistance of the mountain-shepherds, with their leader, Kumbur, in order to check the encroachments of a horde of depredators, headed by an Affghan chief, who infested the country, and even threatened to attack the seat of government. Kumbur successfully performed the service for which he had been engaged; but having, in a few years, quelled the robbers against whom he had been called in, and finding himself at the head of the only military tribe in the country, he formally deposed the rajah, and assumed the reins of government.

The history of this country, subsequently to the accession of Kumbur, is involved in the same obscurity as during the Hindoo dynasty. It would ap-

BELL ROCK LIGHT HOUSE

DURING A GALE FROM THE NORTH EAST.

PLATE XXXIII.



Painted & Engraved by W. & D. Lithers Edinburgh from a Drawing by W. Linnell & J. S. Sandman of the office of Mr. Stevenson Engineer.

Published by A. Constable & Co. 1846.

Beloochistan. pear, however, that the sceptre was quietly transmitted to the descendants of that chief, who seems to have persevered in a peaceable system of government, until the time of Abdoolla Khan, the fourth in descent from Kumbur; who, being an intrepid and ambitious soldier, turned his thoughts towards the conquest of Kutch Gundava, then held by different petty chiefs, under the authority of the Nuwwabs of Sinde.

After various success, the Kumburanees, at length, possessed themselves of the sovereignty of a considerable portion of that fruitful plain, including the chief town, Gundava. It was during this contest, that the famous conqueror, Nadir Shah, commonly called Thamas Koolee Khan, advanced from Persia to the invasion of Hindoostan; and while at Kandahar, he dispatched several detachments into Beloochistan, and established his authority in that province. Abdoolla Khan, however, was continued in the government of the country by Nadir's orders; but he was soon after killed in a battle with the forces of the Nuwwabs of Sinde. He was succeeded by his eldest son, Hajee Mohummud Khan, who abandoned himself to the most tyrannical and licentious way of life, and completely alienated his subjects by his arbitrary and oppressive system of taxation. In these circumstances, Nusseer Khan, the second son of Abdoolla Khan, who had accompanied the victorious Nadir to Delhi, and acquired the favour and confidence of that monarch, returned to Kelat, and was hailed by the whole population as their deliverer. Finding that expostulation had no effect upon his brother, he one day entered his apartment, when the prince was alone, and stabbed him to the heart. As soon as the tyrant was dead, Nusseer Khan mounted the *musnud*, amidst the universal joy of his subjects, and immediately transmitted a report of the events that had taken place to Nadir Shah, who was then encamped near Kandahar. The shah received the intelligence with satisfaction, and dispatched a furman, by return of the messenger, appointing Nusseer Khan, Beglenbeg of all Beloochistan. This event took place in the year 1789.

Nusseer Khan proved an active, politic, and warlike prince. He took great pains to re-establish the internal government of all the provinces in his dominions, and improved and fortified the city of Kelat. On the death of Nadir Shah, in 1747, he acknowledged the title of the king of Caboul, Ahmed Shah Abdalli. In 1758, he declared himself entirely independent; upon which Ahmed Shah dispatched a force against him, under one of his ministers. The khan, however, levied his troops, and totally routed the Affghan army. On receiving intelligence of this discomfiture, the king himself marched with strong reinforcements, and a pitched battle was fought, in which Nusseer Khan was worsted. He retired in good order to Kelat, whither he was followed by the victor, who invested the place with his whole army. The khan made a vigorous defence; and, after the royal troops had been foiled in their attempts to take the city by storm or surprise, a negotiation was proposed by the king, which terminated in a treaty of peace. By this treaty, it

Beloochistan. was stipulated that the king was to receive the cousin of Nusseer Khan in marriage; that the khan was to pay no tribute, but only, when called upon, to furnish troops to assist the royal armies, for which he was to receive an allowance in cash, equal to half their pay.

Subsequently to this period the khan frequently distinguished himself by his gallantry and judgment, in the wars carried on by the monarch of Caboul, and, as a reward for his eminent services, the king bestowed upon him several districts, to hold in perpetual and entire sovereignty. Having succeeded in quelling a dangerous rebellion, headed by his cousin Beheram Khan, this able prince at length died, at an extreme old age, after a happy and prosperous reign, in the month of June 1795, leaving three sons and five daughters. He was succeeded by his eldest son, Muhmood Khan, the present chief of Kelat, then a boy about fourteen years old. During the reign of this prince, who is described as a very humane and indolent man, the country has been distracted by sanguinary intestine broils; the governors of several provinces and districts have withdrawn their allegiance; and the dominions of the khans of Kelat have so gradually diminished, that they now comprehend only a small portion of the provinces which were formerly subject to Nusseer Khan.

The territories of the last-mentioned prince are comprised under the following divisions:—1. The provinces of Jhalawan and Sarawan, and the district of Kelat. 2. The provinces of Mukran and Lus. 3. The province of Kutch Gundava and district of Hurrund Dajel. 4. Kohistan, or the Belooche country, west of the desert. 5. The desert. 6. The province of Sinde.

The features of this extensive tract of country vary considerably; but, in general, it may be described as extremely mountainous. A stupendous range, to which the appellation of the Brahoock mountains has been assigned, and which seems to be the primitive root of all the others, springs abruptly to a conspicuous height out of the sea, at Cape Mowaree (or Monze), in north latitude 25°, east longitude 66° 58', whence it takes a north-easterly direction for 90 miles. There it projects a ridge, east by north, the base of which is washed by the river Indus, at the fort of Sehwan. From the separation of this arm, in latitude 25° 45' to that of 30°, the primitive body runs due north, marking the western limits of Sinde, Kutch-Gundava, and a part of See-weestan; and from thence it once more regains its original inclination to the north-east, and decreases in magnitude and elevation so rapidly, that, in the course of 40 miles, it sinks to a level with the hills inhabited by the Kaukers and other Affghan tribes, with which it becomes incorporated. To the westward, the Brahoock mountains send forth many collateral chains, some of which extend the whole length of Beloochistan, and join the mountains of Persia; others elongate southerly till they touch the sea, or come within a few miles of it, and then either take the inclination of the coast, or subside in the low and barren plains in its vicinity; while the main body, or rather its western face, stretches

Beloochistan.

away north-west by north, to the 28th degree of north latitude, where it meets the south-eastern corner of the sandy desert, about the 64th degree of east longitude; and from thence it inclines with a northern aspect, between the north-east and north points of the compass, to Nooshky, in latitude 30° north; from which place it runs more easterly, till at length it gradually sinks, like the eastern front, to a size of equality with the Affghan hills. Besides the Brahoock chain, there are several other ranges of mountains, extending in various directions and ramifications throughout Beloochistan, but all of them inferior to the former in magnitude and height. This stupendous chain is believed to have attained its greatest altitude at Kelat; from which city, according to the natives, whatever route he may pursue, a traveller must descend; but the descent is so very trifling, for a long way on either side of that capital, that it is not perceptible by the eye. Throughout the whole of this country, there are no rivers of such size or importance as to merit particular notice. In general, they have a broad and deep channel from the coast, until they reach the mountains or stony hills, where they become contracted into narrow and intricate water-courses, that are quite dry during the greater part of the fair season; and, in the wet one, swell to terrific torrents, which run off in the course of a few hours after the rain that has filled them ceases.

Rivers.

City of Kelat.

The principal city of this country is Kelat, the capital of the whole of Beloochistan. This city stands on an elevated site, on the western side of a well-cultivated plain or valley, about eight miles long and two or three broad; a great part of which is laid out in gardens and other inclosures. The town is built in the form of an oblong square, three sides of which are encompassed by a mud wall, 18 or 20 feet high, flanked, at intervals of 250 paces, by bastions, which, as well as the wall itself, are pierced with numberless loop-holes for matchlock-men. The defence of the fourth side of the city is formed by the western face of the hill, on which it is partly built, being cut away perpendicularly. On the summit of this eminence stands the palace of Muhmood Khan, chief of Kelat, and nominal Beglerbeg of Beloochistan, commanding a distinct view of the town and adjacent country. That quarter of the hill on which the khan's residence is erected has been inclosed by a mud wall, with bastions; the entrance to it is on the south-western side; and here, as well as at the city gates, which are three in number, there is constantly a guard of matchlock-men. Within the walls, there are upwards of 2500 houses, and the number of those in the suburbs probably exceeds one-half of that amount. These houses are built of half-burnt brick, or wooden frames, and plastered over with mud or mortar. In general, the streets are broader than those of native towns, and most of them have a raised pathway on either side, for foot-passengers, and an uncovered kennel in the centre; the latter of which is a great nuisance, from the quantity of filth thrown into it, and the stagnant rain-water that lodges there. The upper stories of the houses frequently project across the streets, and thereby render the part beneath them gloomy and

wet. This seems a very rude attempt to imitate the bazars of Persia and Caboul. The bazar of Kelat is extensive, and well furnished with every kind of goods; all the necessaries of life may be procured daily at a moderate price. The town is supplied with delicious water from a spring in the face of a hill on the opposite side of the plain, whence it meanders nearly through the centre of it, having the town and suburbs on one side, and on the other the gardens. It is a remarkable property of this spring, that the waters, at their immediate issue from the smaller channels, possess a considerable degree of tepidity, until after sun-rise, when they suddenly become exceedingly cold, and remain so during the day.

Beloochistan.

We have no data from which we can form an accurate computation of the total amount of the population of Beloochistan. The inhabitants are divided into two great classes, distinguished by the appellations of Belooche and Brahoock; and these two are again subdivided into an infinite number of tribes, which it were tedious and unnecessary to enumerate. The most remarkable distinctions between these two classes consist in their language and appearance. The Belooche, or Beloochee language partakes considerably of the idiom of the modern Persian, although greatly disguised under a singularly corrupt pronunciation. The Brahoock, on the other hand, has nothing analogous to the Persian idiom. It appears to contain a great number of ancient Hinduwee words, and, as it strikes the ear, bears a strong resemblance to the dialect spoken in that part of India called the Punjaub. With regard to external appearance, the contour of these two classes seems to differ, in most instances, as much as their language. The Belooches, in general, have tall figures, long visages, and raised features; the Brahoocks, on the contrary, have short thick bones, with round faces and flat lineaments.

Inhabitants.

The Belooches are a handsome active race of Belooches-men, not possessing great physical strength, but inured to changes of climate and season, and capable of enduring every species of fatigue. In their habits they are a pastoral people, and much addicted to predatory warfare, in the course of which they do not hesitate to commit every kind of outrage and cruelty. The lawless excursions in which they frequently engage are called *Chupaos*, and are almost always conducted under the immediate orders of their chiefs. The depredaters are usually mounted on camels, and furnished with food and water, according to the distance they have to go. When every thing is prepared, they set off, and march incessantly till within a few miles of the point where the *chupao* is to commence. and then halt in a jungul, or some unfrequented spot, to rest their camels. On the approach of night they mount again; and as soon as the inhabitants have retired to repose, they begin their attack by burning, destroying, and carrying off whatever comes in their way. They never rest for one moment during the *chupao*, but ride on, at the rate of eighty or ninety miles a day, until they have loaded their camels with as much pillage as they can possibly remove. If practicable, they make a circuit, which enables

Beloochistan.

them to return by a different route from the one they came. This plan affords them a double prospect of plunder, and also tends to mislead those who go in pursuit of the robbers.

Habitations.

Notwithstanding their predatory habits, the Belooches are proverbial for their hospitality. Among them pilfering is considered a most despicable act; and when they once promise to afford protection to any person who may solicit or require it, they will die before they fail in their trust. Their usual habitations are *Ghedans* or tents, made of black felt or coarse blanket, stretched over a frame of wicker-work, formed from the branches of the tamarisk. An assemblage of these *ghedans* constitutes a Toomun or village, and the inhabitants of it a *Kheil* or society, of which there may be an unlimited number in one tribe. These *kheils* are commonly discriminated by some appropriate title, such as the *Umeerte* *kheil*, the Noble Society, *Daode* *kheil*, David's Society, &c. These titles, however, they frequently change with their places of residence. Some of the Belooches, particularly the *Nharoo* clans, prefer mud houses to tents, and even live in forts; nor is it uncommon, in the western parts of Beloochistan, to find one half of the *keil* residing in *ghedans* and the other in huts. When a visitor arrives at a toomun, a carpet is spread in front of the door of the *Mihman Khanu*, or house for guests, of which every village has one; the *Sirdar* or head of the *kheil* immediately appears, and he and the stranger having embraced, and mutually kissed hands, the followers of the latter successively approach, and the *sirdar* gives them his hand, which they press to their foreheads and lips. The parties then sit down, on which the chief addresses the stranger, and asks him, four several times, how he does, to which the other answers in the usual complimentary terms; he then inquires, in the same manner, for his family and friends, and even for the health of his followers who are present, to whom the visitor turns, as if to appeal for information: they all nod assent to being in good health; and the ceremony concludes by the new-comer making an equal number of inquiries for the welfare of the family, *kheil* or society, followers and friends of the *sirdar*.

Reception of Visitors.

Food.

The food of the Belooches consists of wheaten and barley cakes, rice, dates, cheese, and milk, which last they prefer in a sour state; soup made from *dholl* or peas, and seasoned with red pepper and other heating herbs, and flesh-meat whenever they can procure it. The vegetables most esteemed by them are onions, garlic, and the leaves and stalk of the *assafetida* plant, which they roast or stew in butter. They usually limit themselves to one or two wives, and their chiefs to four; but this depends altogether upon choice. They treat their women with attention and respect, and are not so scrupulous about their being seen by strangers as most other Moosulmans. They keep a great number of slaves of both sexes, captured during their *chupaos*, who are treated with liberality and kindness. The common dress of the Belooches is a coarse white or blue calico shirt, buttoning round the neck, and reaching below the knee; their trowsers are made of the same cloth, or

Women.

Dress.

a kind of striped stuff called *Soosee*, and puckered round the ancles. On their heads they wear a small silk or cotton quilted cap, fitted to the shape of the skull, over which, when in full dress, they place a turband, either checked or blue, and a *kummurbund* or sash, of the same colour, round their waists. In winter, the chiefs and their relatives appear in a tunic of chintz, lined and stuffed with cotton; and the poorer classes, when out of doors, wrap themselves up in a surtout made of cloth, manufactured from a mixture of goats' hair and sheep's wool. The women's dress is very similar to that of the men; their trowsers are preposterously wide, and made of silk, or a mixture of silk and cotton. A Belooche soldier carries a matchlock, sword, spear, dagger, and shield, besides a multiplicity of powder-flasks, priming-horns and pouches. They are all capital marksmen, and in battle avoid, as much as possible, coming to close combat. Their best warlike weapons are of foreign manufacture. At Kelat, there is an armoury for the manufacture of matchlocks, swords, and spears; but the workmanship is very indifferent.

Beloochistan.

Warlike Weapons.

The principal amusements of the Belooches are shooting, hunting, and coursing; for which latter purpose they bestow a vast deal of attention in the training of their greyhounds. Firing at marks, cudgelling, wrestling, and throwing the spear, are likewise favourite diversions among them, and neighbouring *kheils* frequently cope with each other at these exercises. Their funeral and marriage ceremonies, being in a great measure such as are prescribed and regulated by the Koran, are similar to those of all other Moosulmans, and therefore merit no particular notice. With regard to religion, the Belooches are, with a very few exceptions to the westward, *Soonee Moosulmans*.

Amusements.

Religion.

The *Brahooés*, or second great class of the natives of Beloochistan, are a still more unsettled and wandering nation than the Belooches. They reside in one part of the country during the summer, and emigrate to another for the winter season; and even change their immediate places of abode many times in the year, for the sake of pasturage for their flocks. The *Brahooés* are distinguished for activity, strength, and hardiness; inured alike to the cold of the mountainous regions of Beloochistan, and the heat of the low plain of Kutch Gundava. They are very laborious in husbandry, and other domestic occupations; and those who reside in the vicinity of the plains to the southward of Kelat, cultivate large tracts of land, and dispose of the produce for exportation to the *Hindoos* of Kelat, Bela, and *Khozdar*. This, and the sale of the cheese and *ghée* made from the flocks, with a few coarse blankets, carpets, and felts, constitute their only traffic. They are famous for having voracious appetites, and devour a great quantity of flesh in a half dressed state, without bread, salt, or vegetables. The *Brahooés* are as faithful in adherence to their promises, and as hospitable as the Belooches: They are more quiet and industrious; and although they are esteemed superior to the other inhabitants of Beloochistan in personal bravery, and the endurance of privations and hardships, yet their habits are decidedly averse

Brahooés.

Beloochistan.

from that system of rapine and violence pursued by their neighbours. A Brahoóé always dresses in the same style; whether it be summer or winter, his whole clothing consists of a loose white shirt, a pair of trowsers of the same texture, and a felt cap. The shepherds sometimes wear a covering of white felt, made so as to wrap round the body, and come to a peak above the crown of the head; this habit is used as a defence against rain or snow. The domestic life of the Brahoóés is extremely simple: The men employ themselves in field labour, in which, if necessary, they are assisted by the women; but in general the latter are engaged in attending to the household affairs. The dress of the women consists of a long shift and pair of trowsers, both of cotton cloth; and after they arrive at the age of puberty; they wear over the former a kind of stays, made to lace behind, and decorated in front with ridiculous devices of birds or animals, worked in coloured worsted. In religion, the Brahoóés are all Soonnitte Moosulmans. All their tribes intermarry with each other, except the Kumburanees, regarding whom there is a peculiarity which does not attach to any of the other tribes; that of being divided into three distinct gradations of rank, the Ahmedzgees, Khanees, and Kumburanees. The first consists of the family of the prince; the Khanees are of the secondary rank, of whom there are between twenty and thirty; and the Kumburanees include the remainder of the tribe; although, in general, the term is applied to the whole body.

Hindoos.

Besides the Belooches and Brahoóés, there is a considerable number of Hindoos resident at Kelat, who are principally engaged in mercantile speculations, and are much respected both by the government and people. Their religion is tolerated; and they have a pagoda at Kelat. The Dehwars, or Dehkans, constitute the only remaining class of the population, which seems worthy of particular notice. They are to be recognised in different districts of the country under various names; quiet and harmless in their disposition, and addicted to agricultural pursuits. Their colloquial language is common, pure Persian; from which fact their origin may be deduced, although no traces of their first settlement have been discovered.

Dehwars.

Government and Laws.

The fluctuation of power renders it difficult to define precisely the nature of the government at Kelat. During the reign of Nusseer Khan, the whole kingdom might be said to have been governed by a complete despotism; yet that ruler so tempered the supreme authority by the privileges granted to the feudal chiefs, within their own tribes, that, to a casual observer, it bore the appearance of a military confederation. The tribes all exercise the right of selecting their own *Sirdár*, or head; the Khan, indeed, has the power of confirming or disapproving of their nomination; but this power is never exercised, and appears to be merely nominal. The Khan of Kelat has the power of declaring war, and making treaties, connected with the whole of Beloochistan, and can order the *Sirdar* of each tribe to attend in person with his *quota* of troops. Agreeably to a code of regulations framed by one of the earliest princes of the Kumburanees dynasty, the entire ad-

Beloochistan.

ministration of justice was vested in the person at the head of the government. The *Sirdar*, however, has the power of adjusting petty quarrels, thefts, and, in short, disputed points of every description, among the inhabitants of a *kheil*, or society; but in all cases of importance, an appeal lies, in the last instance, to the Khan at Kelat.

A register of the Belooche army, drawn up during the reign of Nusseer Khan, exhibits an aggregate of 250,000 men, but the number was probably exaggerated. At present the same documents comprise a list of 120,000 troops, after excluding all the revolted provinces and districts; but it is believed, that Muhmood Khan could not, on the greatest emergency, muster more than half that number of fighting men. His total revenues, in their present reduced state, may be estimated at 350,000 rupees annually, a large portion of which is paid in produce. In Nusseer Khan's time, the revenue exceeded 30 lacks of rupees. The duties levied at Kelat are extremely moderate. Horses or cattle pay nothing whatever throughout the Belooche territories; but there is a species of land-tax, payable from all cultivated grounds. The exports from Kelat are, at present, very trifling; its imports are iron, tin, lead, steel, copper, beetel-nut, cochineal, sugar, spices, silks, keemkhab, gold-cloth, chintz, and coarse woollens from India.

Revenue.

Exports and Imports.

The climate of Beloochistan is extremely various in the different provinces. The soil, in general, is exceedingly stony. Of the province of Kutch

Climate and Soil.

Gundava, however, the soil is rich and loamy, and so very productive, that, it is said, were it all properly cultivated, the crops would be more than sufficient for the consumption of the whole of Beloochistan. Gold, silver, lead, iron, tin, antimony, brimstone, alum, sal-ammoniac, and many kinds of mineral salts and saltpetre, are found in various parts of the country. The precious metals have only been discovered in working for iron and lead, at mines near the town of Nal, about 150 miles south-west of Kelat. The different other minerals, above enumerated, are very plentiful.

Metals and Minerals.

The gardens of Kelat produce many sorts of fruit, which are sold at a very moderate rate, such as apricots, peaches, grapes, almonds, pistachio nuts, apples, pears, plums, currants, cherries, quinces, figs, pomegranates, mulberries, plantains, melons, gwaivas, &c. All kinds of grain known in India are cultivated in the different provinces of Beloochistan, and they have abundance of vegetables. Madder, cotton, and indigo, are also produced; and the latter is considered superior to that of Bengal. The culture of the date fruit is conducted with great attention in the province of Mukran. The domestic animals of Beloochistan are horses, mules, asses, camels, dromedaries, buffaloes, black-cattle, sheep, goats, dogs, and cats, besides fowls and pigeons. They have neither geese, turkeys, nor ducks. The wild animals are lions, tigers, leopards, hyenas, wolves, jackalls, tiger-cats, wild dogs, foxes, hares, mongooses, mountain-goats, antelopes, elks, red and moose-deer, wild asses, &c. Of birds they have almost every species to be met with either in Europe or India.

Fruits.

Grain, and other Productions.

Domestic and Wild Animals.

For the information contained in this article we

Benefit Societies.

are entirely indebted to the *Travels* of Lieutenant Pottinger, recently published; whose journey, undertaken by authority of the East India Company,

must be regarded as furnishing a valuable addition to our geographical and statistical knowledge of the Asiatic Continent.

Benefit Societies.

BENEFIT SOCIETIES.

Definition and Object.

THE general conception of these institutions may be shortly expressed. A number of individuals associate together, and, by payments made at stated times, create a fund, out of which they receive certain specific sums on certain specific occasions.

The people, whose course of life is most apt to present to them occasions where sums of money, derived from other than their ordinary resources, are of great importance to them, are those of whom the ordinary resources are the most scanty; in other words, the whole mass of the people employed in the ordinary and worst paid species of labour.

The occasions on which sums of money, derived from other than their ordinary resources, are of most importance to these classes of the people, are those on which the ordinary sources are diminished or dried up,—those of sickness, disablement, and old age.

Benefit Clubs are, accordingly, associations of persons of the rank thus described, who agree to make certain payments, in general so much a-month; in consequence of which, they receive certain sums, proportioned to the money which they pay, in times of sickness, of disablement, and in old age.

History.

Sir F. M. Eden, in his work on the Poor, refers to Hickee's *Theaurus* for a proof that Benefit Clubs are of very ancient date, as the *Gilds* of our ancestors were nothing but associations of the same description. A Saxon MS. in the Cottonian Library contains the constitution of a *Gild*, or *Sodalitas*, as it is rendered by Hickee, a Friendly or Benefit Club, established at Cambridge.

"It was first of all," says the MS. "agreed, that all members shall, with their hands upon the sacred relics, swear that they will be faithful to one another, as well in those things which relate to God as those which relate to the world; and that the whole society will always help him who has the better cause. If any member dies, the whole Society shall attend his funeral to whatever burying-place he himself may have chosen; they shall defray one half of the expence which is incurred by the funeral entertainment; and each member shall further pay two-pence, under the name of alms. If any member kill another, he shall pay not more than eight pounds, in the way of satisfaction. But if he who has committed the murder refuses to satisfy, the whole club shall revenge their brother, and all shall contribute to the expence. If any member, who is poor, shall kill a man, and have satisfaction to make; and if the person killed was worth one thousand two hundred shillings, every member shall contribute half a mark, and so in proportion. If any member shall address

another with coarse and uncivil language, let him pay a sextarius of honey," &c.

From the same source we have the formula of another *Club* or *Gild*, formed at Exeter. After the religious services which the members were to perform for themselves, and for one another, it is ordained, "that when any member shall go abroad, each of the other members shall contribute fivepence; when the house of any one is burnt, each shall contribute one penny. If any one neglects the appointed times of meeting, he shall be fined; for the first offence, the price of three masses; for the second, the price of five; if, after admonition, he is absent a third time, without substantial ground, of sickness, or other cause, he shall not be excusable. If any member shall use towards another gross and uncivil language, he shall make compensation by thirty pence."*

Gilds, we are told, did not confine themselves to cities, though it is only in cities that the vestiges of them remain. Little *Gilds*, it appears, were established in every parish. And of all those unions, the object was to entitle each of the members individually, on certain occasions, on which it was most apt to be required, to receive pecuniary or other specified aid from each of the rest.

Sir F. M. Eden speaks of Clubs which had existed in the north of England, for the purposes above described, above one hundred years; and there is a treatise on the poor laws by Mr Alcock, printed in 1752, which represents a number of them as existing at that time in the west of England. From that time to the present, they have been gradually multiplying; and have grown so numerous, within the last fifty years, as to have become an object of great importance in our national economy, and one of the most striking manifestations of virtue that ever was made by any people.

For persons merged in poverty, and totally deprived of education, as the English population heretofore have so generally been, it is not easy or common to have much of foresight, or much of that self-command which is necessary to draw upon the gratifications of the present for those of a distant day. When a people thus situated have a provision made for them, to which they can with certainty have recourse, as often as they themselves are deprived of the means of earning their own subsistence; and yet, notwithstanding this security, choose to form themselves almost universally into Benefit Societies, in order that, by taking something from the means of their present scanty enjoyments, they may in sickness, disablement, and old age, be saved from the necessity of having recourse to public charity, and

Striking Feature in these Institutions.

* See Hickee's *Theaurus*, T. II. *Dissertatio Epistolaris*, p. 20, 22.

Benefit Societies.

may continue to live to the end of their days upon the fruit of their own labour, no burthen to the public, or dependent upon its bounty,—they exhibit a combination of admirable qualities, the existence of which could hardly be credited, if it were not seen; above all, in a country in which the higher ranks too often display an eager desire to benefit themselves at the public expence.

Constitution and Rules of these Societies.

There is much similarity in the constitution of these societies. The rules and regulations of from twenty to thirty of those established in the metropolis, as well as those of several in other places, have been perused for the purpose of this article. The payments are, in general, monthly, and about two shillings the most common amount; though sometimes associations are formed of persons whose incomes are fixed pretty high, and then the payments are somewhat larger. The mode of regulating the benefit is commonly by three different rates of allowance; one during a temporary sickness; another, commonly one half of the former, during a chronic illness; and a third, still less than the preceding, a permanent annuity for old age. When a member falls sick, so as to be unable to labour, he receives the allowance for sickness; if the disease continues beyond a specified number of weeks, he is reduced to the chronic allowance; if the chronic illness continues beyond a certain number of months, the member is put upon the superannuation list, and receives the allowance for old age. Besides these rates, there is almost always a sum of several pounds which is paid for the funeral expences of a member or his wife. It is one of the ill-grounded desires of the least instructed part of the population of this country, to have what they call a decent, meaning by decent, an *expensive*, funeral. As this is so much absolute waste, a consumption for which nobody is the better, and ravaged from a suffering family at a moment when most commonly their resources are diminished, or rather destroyed, the sooner they can be weaned from this superstition so much the better. It might soon be done by the example of their superiors. If those among them who are above vulgar error would enjoin their successors to put them in the earth at the smallest expence which the physical operation would admit, the childish passion for a costly funeral would soon disappear. It is necessary that sepulture should be performed in places, and by persons pointed out by the proper authority, for the security due to the health of the living. But if the business of the cemetery is not performed altogether at the public expence, and in the same manner for all, which would be the best regulation, there assuredly ought to be no fees, nor any charge beyond the rigid payment of the labour. When the religion of the relatives requires a devotional service to be performed at the grave, it ought assuredly to be performed without any fees or presents to the actors in the scene. Fees to the clergyman, and others, in a church of England funeral, are a serious grievance to the poor.

The mode of doing the business is exceedingly simple. When the society is not numerous, there is, in general, a monthly meeting of all the members. When they are numerous, a committee is formed, of

Benefit Societies.

which the meetings are monthly; and general meetings, at more distant periods, are held of the whole. Two or more stewards, as the business may require, are chosen at certain short intervals, whose business it is to visit the members applying for relief, and to pay their allowance. Members are admitted only within a specified age, most commonly between twenty and forty-five; and the persons belonging to occupations regarded as unwholesome or dangerous, are excluded by name from most of the clubs not expressly established for themselves. There are some curious exclusions in most of the London societies. From a great proportion of them, Irishmen are excluded; and in almost all of them, it is particularly declared, that no *attorney*, or *attorney's clerk*, shall be admitted a member.

Some of their rules are in a very remarkable manner favourable to virtue. In almost all the London clubs, it is a rule that sickness or disablement, produced by drinking, by the venereal disease, or by fighting, except in self-defence, shall receive no benefit. If any member, while in the receipt of an allowance, is found gaming or intoxicated, or out of his own house after a certain hour in the evening, he is subject to heavy penalties, very often expulsion. If any member appears at a meeting of the society in a state of intoxication, or uses rude or provoking language to any person present, or is guilty of profane cursing and swearing, or offers wagers, he is fined; in some cases he is fined if he comes to the meeting without being clean in his dress and person; and, in other cases, attention to this object is recommended without being enforced.

Of some of the rules, which are also very generally adopted, the reason is not so easily seen. One of them is, that none of the members shall belong to any other association of the kind. If a member complies with all the rules of one society, it can be of no detriment to that society, if he belongs to another. A man whose earnings place it in his power, may thus secure to himself a double benefit in sickness, disablement, or old age. It would lead to the same end if a man was allowed to take more than one of what may be called the shares of one society, double, for instance, the monthly and other payments, on condition of receiving all the allowances double; but his security, as long as clubs are on a precarious footing, would be somewhat increased by dividing the risk.

By another of these rules, the utility of which seems rather more than doubtful, a member, while receiving aid, is not allowed to work. The intention of this is sufficiently evident. It is to prevent that sort of imposition to which the societies in question are most exposed, receipt of bounty at seasons when it is not required. The question is,—whether if a man was allowed to earn, were it ever so little, as soon as he was capable, and even, when entitled to relief, to divide the produce with the club; deducting, for example, from his allowance, a portion equal to one half of his earnings,—both parties would not find their account in it? and whether means might not to be discovered of guarding against imposition as effectually in that case as by the expedient which is now in use? In the case of the superan-

Benefit Societies.

mination annuity, the member is, in general, at liberty to do any thing which he can for himself, provided his earnings go not beyond a particular amount.

Such, then, in a general point of view, is the end aimed at by these societies, and the means through which they endeavour to accomplish it.

We shall next consider the effects which they have a tendency to produce.

Effects produced by these Societies.

The effects which they have a tendency to produce, regard either the individuals themselves, who are the members of the societies, or the community at large.

1. The effects which they most immediately produce with regard to the individuals themselves, are two; *first*, They deduct somewhat from the ordinary enjoyments; *secondly*, They diminish greatly certain occasional pains; and there can be no doubt that what is lost by the diminution of the ordinary enjoyments, is much more than compensated by what is gained in the diminution of the extraordinary pains. The pains are either those of want, in times of sickness and disablement, where no provision is made for the poor, or those of disgrace and aversion, where relief may indeed be received, but in a way inconsistent with all sense of independence, and in general various little habits from which the idea of happiness can no longer be disjoined.

Under this head, something may perhaps be allowed on the score of temperance. Of the money paid by the members to the club, part, if not so paid, might have been spent upon intoxicating liquors, by which the health and strength would have been impaired.

2. The effects which Benefit Clubs produce in regard to the public, are either pecuniary or moral. Whatever portion of money would otherwise have been spent by the public in maintaining, during sickness, disablement, and old age, the persons who, in these circumstances, are maintained by the clubs, this exactly is the pecuniary advantage which accrues to the public.

The moral effects are not so easy to define. But circumstances present themselves in sufficient abundance to prove that they are not inconsiderable. In whatever degree they contribute to diminish the use of intoxicating liquors, they weaken one of the grand causes of the uselessness and mischievousness of human beings. In whatever degree they contribute to keep alive the sensibility to disgrace, they preserve one of the greatest of all incentives to useful conduct, and one of the greatest securities against a course of life, either mischievous or useless. That they contribute greatly to keep alive the sensibility to disgrace is not to be disputed. It follows that they contribute greatly to all that virtue and good conduct of which the labouring classes of this country are day after day displaying a greater and a greater share.

Compared with Savings Banks

Since Frugality Banks became the fashion, it has been customary to allege, that all the benefits capable of being derived from Benefit Clubs, and still higher benefits, may be derived from the banks, and with the avoidance of several evils. It will not require many words to enable us to effect a comparison. We shall follow that division of the effects,

into those regarding the individuals, and those regarding the public, which was presented above.

Benefit Societies.

1. In regard to the individuals, it is supposed that the banks will make them save more eagerly. If this enables them to make a greater provision for the seasons of distress, it is good; if not, all that they would have spent in innocent enjoyments is so much good lost.

First, in regard to Individuals;

But it may well be questioned whether banks are calculated to make them save more rigidly. The idea of a stock which they may leave behind them is something. But the idea of a better provision for the occasions of their own distress is something also; and with the greatest number, it is probable, the greatest something of the two.

With regard to the convenience of taking the money in small sums, the monthly payments of two shillings, are nearly as small as can be desired. If this is too small for the rate of any man's abilities, there might in each society be different rates, or one man might belong to several societies.

A circumstance which has been urged more strongly is, the inconvenience of paying, as required in Benefit Clubs, on a particular day; to banks the payment is made whenever it is convenient. This has its advantages, and its disadvantages. The disadvantages appear to exceed the advantages. With this opinion Mr Duncan was so deeply impressed, that he thinks stated payments, with penalties, a proper law for Frugality Banks. "Though it may bear hard," he says, "on a contributor to be bound to pay annually a stated sum, as in Friendly Societies, under the pain of forfeiting the whole, it is, notwithstanding, useful in such institutions, that some strong motive should exist for regular payments. The reason on which this opinion is founded, must be obvious to all who know any thing of human nature. What we have no pressing motive to do at a particular time, we are apt to delay till it is beyond our power to do at all. So sensible are the common people themselves of this tendency, that we frequently observe them having recourse to contrivances for forcing themselves to save money for a particular object. It is partly on this principle that Friendly Societies find so many supporters; and that there are such frequent associations among the lower classes, with the view of raising funds, for the purchase of family Bibles, or some of the more expensive articles of furniture." (*Essay on Parish Banks*, p. 24.)

This important fact, of the voluntary associations of the people to raise funds, not merely for support in seasons of distress, but for the purchase of articles of fancy and luxury, is a strong argument in favour of Clubs. It shows two things; it shows the pleasure the people take in them; and it gives the experience of the efficacy which attends them.

The difficulty of making good the stated payments to the club, at moments of great pressure, as when employment is wanting, or a man's wife and children are sick, is objected to Benefit Societies. This is an inconvenience, no doubt; but we have seen that it is not unattended with compensation. In fact, a man must be in a state of distress very uncommon, if he is prevented by real necessity from paying his

Benefit Societies.

club-money. Besides, this is one of the occasions on which very extraordinary exertions are made by his acquaintance and friends; especially if he is not a man thoroughly worthless, whose vices, not his misfortunes, are the cause of his distress, to supply him with the means. And this is an exercise of virtue in these acquaintances and friends, which is highly useful; and tends forcibly to the increase of the benevolent feelings in the minds both of those who make it, and of those in favour of whom it is made.

It is urged as a hardship of great magnitude, that a man, after he has been a long time a contributor to a club, should lose the benefit of the whole, for a delay in payment at a season of peculiar distress. But a certain degree of indulgence is allowed; a defaulter does not forfeit till the first meeting, which is a month after the quarter-day. Besides, it is very common to misrepresent the amount of the loss in this case. What a man really and truly loses is that which will be necessary to place him in the same situation. But that is only as much as will be necessary to entitle him to the allowances of another club. This may be nine or twelve months' contributions. Suppose the rate of contribution is 2s. a-month, and 5s. of entry-money. What a man loses by expulsion, however much he may have paid, is only 29s. If, indeed, he is an old man, past the age of admission into another club, what he loses is much more serious; it is the value of all the benefit which he would have been entitled to derive. And, in this case, some modification of the rule of forfeiture would be desirable. It is, however, no fundamental objection, because such a modification may be easily made. Lastly, the number of those who suffer forfeiture from real necessity, and not from their vices, is small, bearing a very insignificant proportion to the whole. For a hardship to the very small number, a great benefit to the very great number is not to be foregone. This is the very principle on which bad government is distinguished from good.

It is brought as a strong argument against Benefit Clubs, that the meetings are held at public-houses. From this, it is inferred, that the members are at these meetings very commonly seduced to drink; and acquire, increase, or confirm habits of intemperance. This appears to be an inference altogether unwarranted, and contrary to the fact. The members are, in general, under the necessity of holding their meetings at a public-house, because it is only at a public-house where they can, in general, hire an apartment for the purpose. The use of the apartment is sometimes paid for by the money spent, which is always a limited, and always a very small sum, threepence most commonly, or a pint of porter for each; and sometimes the room is paid for, not in this way, but by the contribution of a penny or other small sum from each; and intoxication, at the time of meeting, is punished with a fine. It is affirmed by those who have most attended to the practical proceedings of these societies, that instead of being a source of intoxication, they have been one of the grand causes of its decrease.

One decided advantage which the Benefit Clubs

possess above the Savings Banks is, that the money paid to the club cannot be taken out, first, to gratify any unnecessary desire; secondly, to buy furniture for the sake of an early, and hence, in all probability, a fruitful, that is, a deplorable marriage; thirdly, to satisfy the parish for a bastard, which often would not have been gotten, but for the reflection, that if the worst came to the worst, means were had to get rid of it.

In a moral point of view, the formation of the people into little combinations and fraternities is of the greatest importance. It concentrates the eyes of all upon each individual; and renders good conduct a thing of infinitely more value to him, as it renders bad conduct for men detrimental. It is this circumstance which the sage mind of Dr Adam Smith loads with such emphatic praise in the supposed case of the division of a country into so great a number of religious sects, that each congregation might be regarded as differing from the rest. In this manner, without difficulty, and without care, is exercised one of the most vigilant and effectual of all censorships; the most salutary of all inspections. When an ignorant, or almost any man can say to himself, my conduct is regarded by nobody,—it is astonishing how easy it is for temptation to subdue him; when he must say to himself, I cannot perform a disgraceful act without reading aversion and contempt in the eyes of all my acquaintance,—it is astonishing how much he is strengthened for resistance.

There is yet another thing of cardinal importance. If it were possible for the superior to do everything for the inferior people, and to leave them nothing to do or care about for themselves, nothing would be more calamitous than the accomplishment of such an event. The mass of the human species would thence become what the people of Paraguay became in the hand of the Jesuits; most perfectly helpless, and ready, on the least derangement in the machinery which conducts them, to fall into the deepest wretchedness and barbarity. As that machinery would be liable to be deranged by the slightest accidents, it could not be preserved in order long, and would then serve as an introduction, a necessary and certain introduction, to one of the most deplorable conditions of human affairs. The case is altogether different where the power of suffering for themselves is generally spread throughout the community; where the people have resources; where every man is accustomed to combine for himself the means of warding off evil, and attaining good. There the machine of society cannot be easily disordered, and human happiness is placed on a much more secure foundation. Then, if any of the larger arteries of the body politic is obstructed, the nourishment of the system is carried on by the admirable service which may be rendered by the smaller. To a system which has thus a *vis medicatrix* in all its parts, no shock can be given that is not immediately repaired. Were the greatest disorder introduced, things of their own accord would hasten to their proper place.

It is, therefore, a prodigious recommendation of Benefit Societies, that in them the people act for themselves. We do not mention this, however, as one of the circumstances in which they differ from

Benefit Societies.

Benefit Societies.

Savings Banks. It is, indeed, true, that in most of the Savings Banks which have yet been started, the upper people have taken upon them to manage for the under. But this is not necessary. The contributors to Savings Banks may themselves, if they choose, manage a bank just as well as a club-box; in fact, the business of the bank is far more simple than that of the box. There is one important example of a bank conducted by the people themselves, in that established in Clerkenwell, at the suggestion of Charles Taylor, Esq.

So much with regard to the effect of Benefit Societies, as compared with Savings Banks, in promoting economy and other good qualities among the contributors. Let us next compare them with regard to the benefit received. This part of the subject has already been so well handled by the Reverend Richard Vivian, rector of Bushey Herts, in *A Letter on Friendly Societies and Savings Banks*, published in 1816, that it would be improper to do anything more than transcribe what he has written.

“For a view of the powers of the institutions, to secure independence, let Mr Rose’s table be compared with the Benefit Society long established in this parish. By the table the amount of *one shilling per week* after one year is L. 2, 12s. If the contributor should be ill at the beginning of this year, there is nothing for him: if quite at the end of the year, he should be ill four weeks, and should draw equal to the allowance of the Bushey Benefit Society, his capital is gone; and he must begin again. A member of the society pays *two shillings per kalendar month*, and, if he has paid one pound to be free, supposing him under twenty-five years of age (and other ages in proportion), he will receive 12s. a-week during illness in any part of the whole of the year; and will find his right to the same payment for future years undiminished. There is no occasion to go through the intermediate years. Let us take the twentieth. After twenty years, the contributor to the bank (if he has had no illness, which would quickly have exhausted his stock, especially in the earlier years) will have paid L. 52, and will be worth L. 77, 8s. 6d. We will suppose that he is come to old age, or some lasting infirmity. He can afford 6s. a-week for five years, and then comes to the parish, with the aggravation of disappointed hopes of independence. In the society the payments in twenty years will amount to L. 24; the receipt 6s. a-week in old age, if his life should be protracted to the (I hope incalculable) date of a national bankruptcy.

“You will perceive, that the great defect of Savings Banks is the want of benefit of survivorship. But (say their advocates) there are the advantages of bequeathing their stock, and of taking their money, whenever they want it; the advantage of bequeathing I will leave to be estimated by the most sanguine admirers of Savings Banks, only desiring them to take into their account, the high probability that his little stock will be hardly worth bequeathing, even if not exhausted by the illness of the testator, in the case of his dying in youth; and the certainty of his being his own heir, if he should die in his old age. The power of taking out the money at any time is the very circumstance which

Benefit Societies.

fills me with alarm. There is danger lest the subscriber should leave his club, and become a contributor to a bank, from the fallacious hope of enjoying this advantage *in addition* to all the others. No doubt this may be an advantage to prudent persons in certain situations. But is there no danger of cases, which I might have mentioned before, in which the stock will be sunk in unfounded projects, in wanton expences, in a childish impatience of possessing money? All this imprudence would be of comparatively little consequence, if the parties were by any means protected from absolute want; that is to say, if they were, at the same time, members of Benefit Societies.

“The truth is, Savings Banks are not calculated for the lowest and most numerous rank of the community. This is evident from Mr Rose’s table, beginning with 1s. *per week*. Many members of Benefit Clubs cannot make good their payments of less than half that sum without the best charity that can be bestowed by the rich—assistance towards the payment of their subscriptions to members of Benefit Clubs, with large and helpless families. Men in elevated stations imagine that they see the *lowest* order, when they see but the lower. The “*Corinthian capital*” looks down, and mistakes the cornice of the pediment for its base. While the great are providing for their immediate dependants, they seem to be providing for the poor. I do not wish to retort upon some of the defenders of Savings Banks, and by exaggerating their possible ill effects to exalt the merit of Benefit Societies. Savings Banks have done, and I hope will continue to do, much service to many. They often lift a little higher them who are not already very low. But a man should be secured from sinking into absolute wretchedness, before he is encouraged to mount into a higher sphere. By a Savings Bank, a butler may lay up money enough to keep a public-house. But there must be a Benefit Society to keep a ploughman and his family from the workhouse. Now, I hope I may be allowed to say, that it is better that one ploughman should be preserved from a receptacle of misery, than that ten butlers should be exalted into publicans.”

Even Mr Duncan says, “There is one point of view in which the Friendly Society scheme can claim a decided advantage. An individual belonging to the labouring part of the community cannot expect, by making the most assiduous use of the provisions of the Parish Bank, to arrive at sudden independence;—on the contrary, it is only by many years of industry and economy that the flattering prospects held out by that system can be realized. But health is precarious, and an accident or disease may in a moment put an end to all the efforts of the most active and expert. It is under such circumstances that a very striking difference appears in favour of the scheme we are considering. He who should trust to the progressive accumulation of his funds in a Parish Bank, might now find himself fatally disappointed. If he had not been fortunate enough to realize a considerable capital before the sources of his subsistence were dried up, the illness of a few weeks or months might re-

Benefit Societies.

duce him to a state of want and dependence, and cause him to experience the unhappiness of mourning over impotent efforts and abortive hopes. On the other hand, the man who has used the precaution to become a member of a Friendly Society, has made a comfortable and permanent provision against the sudden attack of disease and accident. The moment that he comes to acquire the privileges of a *free member*, which, by the rules of most of these institutions, is at the end of the third year after he began to contribute, he is safe from absolute want, and the regular manner in which his weekly allowance is paid him enhances its value. Nor is this provision liable to any of those objections, which have been so strongly and so justly urged against the well-intended but mistaken system of poor rates. Instead of degrading and vitiating the mind, its tendency is directly the reverse. The poor man feels that he is reaping the fruit of *his own* industry and forethought. He has purchased by his own prudent care an honourable resource against the most common misfortunes of life, and even when deprived of the power to labour for a livelihood, the honest pride of independence remains to elevate and ennoble his character."

It is objected, that Benefit Societies have been established on improper calculations, and thus have come to ruin. But this is an evil which has a tendency to correct itself. Experience, if there were nothing else, discovers what rate of benefit the payments can afford, and the thing is now so well understood, that mistakes, it is probable, are very seldom incurred. At any rate, this is a chance of evil which may always be precluded by communicating information.

The funds, it is said, of Benefit Societies, are often confided to improper hands, and by consequence lost. This, too, is an evil, which, so far from being necessary, has a sure tendency to correct itself. People learn by a little experience where their money may be safely lodged. It is, indeed, a lesson which probably they have already learnt. We perceive it is a rule in most of the London Societies, that whenever the fund exceeds what is necessary for the current expenditure, it is invested in Government securities. Another thing should be observed, that it is a great advantage of Benefit Clubs not to require much in the way of fund. If the calculations are correct, the outgoings within an average period will balance the incomings; and all that is requisite in the way of fund, is a small sum to meet accidental inequalities. When this fund is lost, it is not much that is lost. If a small additional sum is subscribed by each member; or, instead of this, if the allowances are for a short time suspended, or only reduced, the society is placed in its former situation. The case is wofully different with a bank. There, if the funds are lost, the whole is lost.

Secondly, In regard to the Community.

2. Thus stands the comparison between Savings Banks and Benefit Societies, in regard to the members or contributors. How stands it in regard to the community as a whole?

In the first place, it is evident, that the classes, of whom such members and contributors are composed, being the whole population, with the deduction of a

number comparatively small, it is not easy for any thing which is good for them, one by one, not to be good for the whole conjointly.

Benefit Societies.

Further, if Benefit Societies afford, as appears to be ascertained, a better security for the maintenance of the people, free from public aid, than Savings Banks, the public is benefited to the amount of all the support which otherwise it would have been obliged to afford.

If the moral and intellectual qualities of the people are more favoured by the societies than the banks, the public is benefited in respect to a cause of good, the effects of which are incalculable.

Thus far on the side of good. On the side of evil, a great fear has been expressed, that out of any joint proceedings of the people would arise mischief to the government. The operation of fears of this description has been one grand cause of the evils which human beings have brought upon one another. It is a circumstance full of suspicion, when governments count upon the hatred of their people. It seldom happens, and seldom can happen, unless when they know well that the people have reason to hate them. It is not natural for the people to hate their government, unless oppressed by it. The people, instead of being disposed to hate a good government, are far too much disposed to be pleased with a bad one; as the history of the whole earth so abundantly and wofully testifies. If a government takes care of the interests of the people, and gives them instruction sufficient to know their own interests, that is to say, takes no measures to prevent their instruction (for that, in such a state of society as ours, includes all that is necessary), it will have nothing to fear from the little societies which the people may form, to insure one another against some of the calamities to which they are most commonly exposed. Besides, if ever the people are stimulated to combine against the government, they will find better mediums of combination than the Benefit Societies, which appear to have an unnecessary and improper jealousy of one another.

A fear has been also expressed, that Benefit Societies may be rendered subservient to conspiracies for the raising of wages. Upon this it may be sufficient to observe, that many instances of what the workmen call *striking for wages* have taken place, since Benefit Clubs were frequent; in these instances, other means of combination have always been found; and Benefit Clubs are by their nature ill adapted to the purpose.

Such is the present state of the business of Benefit Clubs in this country at this moment, and such are the effects they have a tendency to produce. The grand cause why more of the good effects which they are calculated to produce have not been realized, is the unhappy state of the law in England.

This deserves a few words of illustration.

For a long time, the unhappy state of the English law rendered the Benefit Societies a mere object of Inconveniences experienced from peculiarities of Law. Any person whatsoever, who found it agreeable to cheat them, might do so with perfect impunity. They had no means of redress. This was owing to one of the fopperies or quaint conceits of the English law, bred in times of ignorance and im-

Benefit Societies
||
Bentinck.

posture, and hugged with ecstasy by the lawyers, in spite of the wisdom of an enlightened age. In consequence of the conceit to which we allude, no assemblage of men could be regarded as one body, or entitled to sue for property possessed in common, unless they had certain ceremonies performed in regard to them,—ceremonies exquisitely useless; after the performance of which, the lawyers would give them a nickname (that of a corporation), and would then permit them to sue as one party, for any cause of action common to them all. The ceremonies, the performance of which gave an assemblage of persons this potent name, depending upon the will of great men, were not easy to be got; nor was the getting of them without an expence fatal to such institutions as Benefit Clubs. They remained, therefore, deprived of the benefit of law till the year 1793, when an act was passed which had two objects in view. One was to take securities against certain dangers at that time intensely associated with the idea of any thing called an assemblage of the people. Another was, to give to Benefit Societies, though without the name corporation, which performs legerdemain, if not magic, in the kingdom of the lawyers, something of the protection of law. The treasurers and trustees, as vested with the property of the society, were enabled to bring or defend any action, suit, or prosecution, relative to the property of the society. But to obtain this advantage, it was rendered incumbent upon the society to make known all its rules to the justices of the peace, and obtain their approbation.

As the expence of law-proceedings was so great, that the expence of a suit, or at least of a few suits, would be completely ruinous to a Benefit Society, something was also done towards the diminution of that expence. It was ordered that no fee should be taken by any officer or minister in the courts, and that the proceedings should not be chargeable with any stamp duty.

This was most undoubtedly travelling in the right path; but it was not doing enough. It did not render the access to justice sufficiently easy. The proceedings of English law are full of delay, and full of intricacy. The business of the great mass of the people, of which Benefit Clubs is a part, requires dispatch and simplicity. A suit at law in behalf of a Benefit Society is still attended with so much trouble, and so much expence, that, virtually, the doors of the Courts are well nigh shut upon them down to the present hour. And this want of the protection of law they are obliged to supply, as well as they can, by rules of their own,—rules of some inconvenience, and of which they would never think, if the protection of law were as it should be.

Thus, with the delay, trouble, and expence of the regular courts, it would never do to sue for arrears, as often as a few shillings became due. The societies are therefore obliged to make a law of their own, that a member who does not at a certain time pay up his arrears, forfeits his place as a member. If a single attendance of a few minutes at a summary court, which would be all that would be required, would suffice to procure a sentence and execution upon the goods of a defaulter, the law of expulsion would not be required.

It is evident that, to give to Benefit Societies all the salutary operation of which they are capable, some court is wanting, where, free from the superstitious perplexities of barbarous law, the matter of all applications may be immediately tried, in the way of natural and rational inquiry; the parties themselves and their witnesses instructing the judge upon their oaths, and receiving his award without delay and without expence. If every man who fancied himself aggrieved by his club, and every club who had a complaint against an offender, could receive justice on these terms, the business of societies would be very simple, and their benefits sure. Their rules might then be limited to the fixing of the periodical payments, apportioning the benefits to be returned, and settling the order of conducting the business. They would attain a sort of ideal perfection, could they only obtain in a degree at all approaching to perfection, the benefit of law. With no other than the functionaries at present in Great Britain administering the law, the easiest mode of composing a judicatory for Friendly Societies would be to make the reference to a single Justice of the Peace, who should hold a regular tribunal for this purpose, and go through immediately, even to execution, with all disputes, reserving one appeal to any of the neighbouring Justices, upon whom the parties should mutually agree. Upon no part of the proceedings should there be the shadow of a tax or a fee; and, as lawyers would be altogether unnecessary, and the witnesses would in general be few and at hand, justice would in general be done without an hour's delay; with the loss, even in the most tedious cases, of but a few hours of time, either to the parties or the witnesses; without any expence in most cases, with a very small expence in any. The consequence would infallibly be, that, in such cases, no man would have any interest in an injustice, for which he would be immediately called before the judge, which he would be immediately obliged to repair, and from which he could therefore derive no advantage, not so much as a little momentary ease.

(FF.)

BENTINCK (WILLIAM HENRY CAVENDISH), third Duke of Portland, was born on the 14th of April 1738. Having finished his education at Christ Church, Oxford, he went on his travels. Soon after his return, he was elected for the borough of Weobly, in the first Parliament of the King's reign. For this borough, however, he did not sit long; for,

on the death of his father, on the 1st of May 1762, he was called up to the House of Peers. He immediately joined the opposition; and, in 1763, his name is found among the minority against the cyder bill, and along with that of the Duke of Grafton, in a protest against it. The next session, he also signed a protest against the motion to vote away the privilege

Benefit Societies
||
Bentinck.

Bentinck. claimed by members of Parliament in matters of libel. In 1765, when his friend the Marquis of Rockingham came into power, he was appointed Lord Chamberlain, and he retired when the Marquis went out of office. In 1768, there was a violent contest for the county of Cumberland; and as the Duke warmly supported the two opposition candidates, the ministry, in order to weaken his influence, and at the same time to increase that of Sir James Lowther, who was one of the ministerial candidates, granted to the latter Inglewood forest, an extensive and valuable estate, which had been granted by King William III. to the first Duke of Portland, and had remained in possession of that family ever since. The new grant was made in consequence of a report from the surveyor-general of crown lands, that the premises were not comprised in the original grant from King William to the Duke of Portland, but were still vested in the crown. A letter was written from the Treasury, directing the Duke to prepare his title, and assuring him that nothing should be decided concerning the grant till such title had been stated and maturely considered; but while his Grace's agents were busily employed in their researches and inquiries, he received a second letter, informing him that the grants were passed, and the leases signed. A caveat had been entered at the Exchequer to stop the progress of the grant, but, when Lord North was prayed to withhold affixing the Exchequer seal, he replied that, as Chancellor of the Exchequer, he was bound to obey the orders of the Treasury. On the 19th of November 1771, this great cause was tried before the Barons of the Exchequer, in Westminster-Hall. The Court recited all the records, and prerogatives of the crown, from Edward I. to the lease made to Sir James Lowther; when, after a full and impartial examination of the said lease, it was found invalid; agreeably to the statute of the 1st of Anne, which expressly requires that, upon every grant from the crown, there shall be a reserved rent, not under the third part of the clear yearly value of the manors, lands, &c. as shall be contained in the grant. Sir James Lowther's grant from the crown being only a quit rent of 13s. 4d. for the whole of Inglewood forest, was immediately determined by the Court an inadequate third proportion, and he was nonsuited accordingly. The *nullum tempus* bill, or the act for quieting the possessions of the subject against all pretences of concealment whatsoever, which was brought into Parliament in 1768, and passed in the following year, owed its rise to this grant of the Portland property to Sir James Lowther.

In 1766. the Duke of Portland had been bound more closely than ever to the Rockingham party, in consequence of his marriage with Lady Dorothy Cavendish, sister to the Duke of Devonshire. On the resignation of Lord North, he was appointed Lord-Lieutenant of Ireland; and, during his government, the Parliament of that country was declared independent of the British Parliament. After an administration of somewhat more than three months, he was recalled, when Lord Shelburne came into power. On the death of the Marquis of Rockingham, he was recommended by the Privy Council to the King

as his successor at the Treasury; but Lord Shelburne was preferred. When the Coalition came into power, however, he obtained the situation of Prime Minister, and went out of office with them. During Mr Pitt's difficulties, when he first came into administration, in consequence of the House of Commons being against him, an attempt was made to form a coalition between him and the Duke of Portland; but his Grace objected to the conditions on which Mr Pitt came into power, and refused his support, unless he would resign his place, and come in again on equal terms with himself and his friends.

In 1792, he was elected Chancellor of the University of Oxford; and, soon afterwards, he, as well as several other friends of Mr Fox, who differed with him respecting the French revolution, left the opposition, and joined the ministry. Upon this, he was appointed Lord-Lieutenant of the county of Nottingham; and, in 1794, Secretary of State for the Home Department. The scarcity and high price of provisions, and the state-trials, which occurred soon after he became Secretary of State, rendered his office arduous and unpleasant. He discharged his duty, however, under these circumstances, with moderation, and with acknowledged good intentions, though not always perhaps with vigour and judgment. He continued Secretary of State, till Mr Addington became Prime Minister in 1801, when he exchanged this situation for the more easy duty of President of the Council. On the death of Mr Pitt, and the appointment of Lord Grenville and Mr Fox to the ministry, in the spring of 1806, he was removed from the Presidentship of the Council; but he was again called into public life, and placed at the head of the Treasury, in March 1807, when Lord Grenville's administration closed. His Grace, however, though nominally the Prime Minister, was too infirm to take an active part in the high and arduous duties of this situation, which were discharged almost entirely by Mr Perceval, the Chancellor of the Exchequer. He continued nominally the First Lord of the Treasury till a very short time before his death, which happened on the 30th of October 1809.

The abilities of his Grace were certainly but moderate, and very far inferior to those which he must have possessed, had he been, as latterly there has been an attempt to prove, the author of *Junius's Letters*; but his understanding was good, and he was by no means unwilling or unable to give regular attention to official business. His political integrity was never questioned, even by the party whom he left.

(c.)

BERBICE is a colony belonging to the British, situate on the banks of the river of that name, in the province of Guiana, in South America. The latitude of the mouth of the river Berbice is 6 degrees, 20 minutes north; and its longitude 57 degrees, 11 minutes west from London. The plantations are situate on each side of the river, and extend nearly 300 miles from its entrance. Previously to the year 1799, this colony was bounded on the east by the Devil's Creek, and on the west by Abarry Creek, which separated it from Demerary, its breadth being then 30 miles. But when Surinam surrendered to the British in that year, a negocia-

Bentinck
|
Berbice:

Situation,
Boundaries,
and Extent.

Berbice. tion was entered into between the Governors of these two colonies, by which Surinam conceded to Berbice the tract of country between the Devil's Creek, and the river Courantine; thus increasing its breadth to about 45 miles. The sea coast, extending nearly 50 miles, and the west bank of the Courantine, were immediately surveyed, and laid out into regular allotments. The extent of this colony was farther enlarged by the British, who cleared and embanked from the sea the whole line of coast between the Demerary and the Courantine, forming upon it a carriage-road 60 feet broad, with six-foot parapets on each side for the convenience of travelling.

Face of the Country. Previously to this improvement, the face of this country resembled that of the rest of Guiana. On the shores there was a border of low ground, between high and low-water marks, covered with mangrove. When the tide flowed, this border had several feet of water over it; and when it ebbed, it presented an inaccessible mud-bank. This is now rendered dry and productive. Behind this border of mangroves, at the distance of 400 or 500 paces, commence low, level, swampy savannahs, formed by the rains, which are prolonged in the direction of the coast, with a depth more or less considerable, according to the distance of the mountains. This part of the colony was almost entirely neglected by the Dutch, who fixed their principal plantations in the more elevated and interior part of the country.

Climate. The year, here, is divided into two dry and two wet seasons; light showers begin to refresh the land about the middle of April; the rain increases till the middle of June, when it falls in torrents; at the beginning of July, these heavy rains begin to decrease; and in August, the long dry season begins, and continues till November. December and January constitute the short and rainy season; and February and March the short dry season. The land winds prevail during the two wet seasons, and are unhealthy; in the dry season, the air is refreshed, by regular, diurnal sea-breezes. The temperature of this colony is not so great as might be expected from its latitude; the thermometer very seldom rises to 91 degrees; in general, during May, June, and July, it varies between 83 and 84; the lowest degree is about 75. The weather always changes very gradually.

Rivers. There are two rivers in this colony; the Berbice, and the Canje. The former runs from south to north, and discharges itself into the Atlantic Ocean. The coast on each side of it forms a bay at its entrance, which is nearly a mile in width, having a small island in the middle, called Crab Island, from the number of land-crabs on it; the entrance is protected by three forts, but they are of little use, as Berbice must, from its situation, always follow the fate of Demerary. Without the entrance of the river is a bar of sand, over which, at high tide, there is sel-

Berbice. dom more than 16 feet of water; but within, the water is of sufficient depth, and the river is navigable, for ships of burden two hundred miles from its mouth. On account of the bar, however, few vessels rendezvous here, but anchor off the port of Demerary.

The river Canje is narrow, but deep, running at first nearly from south to north, but afterwards diverging to the east, till it falls into the Berbice about a mile from the sea. It is navigable for colonschooners 30 miles up. At its head are immense falls, and about 40 miles below, there is a creek which connects it with the Courantine. In this route, and by means of this creek, or island, dispatches are brought from Surinam to Berbice by the Indians. The water on all the coast of Berbice is brackish. The rain-water, which lodges in the low parts of the forests, called bush-water, is collected by the Indians for the purposes of drinking and cooking. The forests are extensive, and contain many very large trees. Dr Pinckard describes an enormous tree of the Tonquin Bean, the body of which rose perpendicularly to the height of between 70 and 80 feet, before it threw out a single branch.

Towns. The only towns in this colony are Old Amsterdam, and Fort Nassau, or New Amsterdam; the former is said, by Bolingbroke, to be 50 miles up the river Berbice, but Dr Bancroft places it at 100 miles from the mouth. The inconveniences attendant on this situation of Old Amsterdam were so numerous and obvious, arising chiefly from the uncertain and intricate navigation of the river, that, in the year 1766, when Dr Bancroft visited Guiana, it was resolved to remove the seat of government to a point of land on the eastern shore of the Berbice (about a mile from its entrance), formed between that river and the Canje. So slow, however, were the Dutch in their operations, that New Amsterdam, for so this town was called, was scarce begun, in the year 1796, when Berbice capitulated to the English. Under the greater activity of the conquerors, New Amsterdam soon assumed the size and appearance of the capital of the colony. It lies on the south side of the Canje; and the houses extend up the banks of the Berbice about a mile and a half, facing the water. The Dutch, in laying out the town, paid particular attention to health and convenience. Round each allotment there are trenches, which fill and empty themselves every tide, so that all the filth is carried off before it stagnates and becomes unwholesome. Each lot contains a quarter of an acre of land; a free circulation of air, as well as ground for a kitchen-garden, is thus secured to the inhabitants. The houses are very long and narrow, and not more than a story and a half high, with galleries on each side, to protect them from the sun. Those inhabited by the Dutch are thatched with troolie* and plantain leaves, which they prefer to shingles on account of coolness; but

* The troolies are perhaps the largest leaves that have been hitherto discovered in any part of the world. Each leaf is supported by a single stem, which arises immediately from the root, and becomes the middle rib to the leaf. These stems are hard and strong, and about three inches in circumference near the root. Each leaf is from 20 to 30 feet in length, and from 2 to 3 feet in breadth. They will effectually exclude the most violent rains, and last for many years.

Berbice. the English shingle their houses, from their dislike of the insects and vermin which the troolie and plantain leaves harbour. The government-house and colonial offices are built of brick, in the European style, and with considerable pretensions to architectural taste and magnificence.

Estates. Before Berbice surrendered to the British, in 1796, almost all the plantations were at a distance from the coast, considerably up the banks of the Berbice and the Canje; but within a very short time after the colony came into our possession, the plantations were greatly extended. The west coast was first cultivated; and in the year 1799, that to the eastward of the river Berbice, as far as the Devil's Creek, was cleared and cultivated. This part was surveyed and cut into two parallel lines of estates, with a navigable canal between them, for the convenience of water-carriage. Behind the second row of estates, the river Canje runs, both the banks of which are cultivated with sugar, coffee, and plantains. The estates are distinguished as follows: those on the line facing the sea are the coast estates; the second line consists of the canal estates; and the remainder are called the Canje estates. Besides these, there are valuable and extensive plantations on each side of the Berbice, stretching, as has been already mentioned, nearly 300 miles from its mouth. The principal and most valuable produce of the colony are sugar, coffee, cocoa, tobacco, cotton, and the arnotta, or roucou shrub. This last was, for a considerable time after the settlement of the colony, cultivated almost exclusively by the Indians; they macerated its seed in the juice of lemons, in which the gum of the manna tree had been dissolved, and thus obtained the celebrated Indian pigment, or crimson paint, with which they adorn their bodies. The roucou is now cultivated by the Dutch and English planters, as a dyeing stuff. Cotton thrives best, and is principally cultivated on the coast estates. The sugar plantations are deemed the most valuable.

Negroes, and Agriculture, and all other labour in Berbice, is almost wholly performed by negroes. On an estate, which, on an average, produces annually 140,000 cwt. of coffee, and 10,000 cwt. of cocoa, there are generally 200 slaves employed, calculated at the value of from L. 50 to L. 100 each. The Indians who inhabit this part of the South American coast, consist of four tribes; from these, particularly, the tribe of the Arrowaucs, the inhabitants derive some assistance, as a few of them reside on almost every plantation, and are employed in various services, particularly in hunting and fishing. They have no animals domesticated, nor any grain or roots, except the cassada, brought into cultivation; a small species of deer, which something resembles the hare, and the armadillo, are their favourite food. They scald off the fur of the deer, cut the body in pieces, and stew it in cassada juice, seasoning it very highly with capsicum. The weapons they employ are the common bow and arrow, and the poisoned arrow, which they blow from a tube. Their accuracy and skill in using both these is surprising. With the common arrow, which is formed of a reed nearly six feet long, they can hit a chicken with tolerable certainty at nearly 100 yards distance. The

Indians.

poisoned arrow they can shoot from a tube of about seven feet in length, to the distance of eight or ten yards, with great accuracy; and, at 12 or 14 feet distance, they seldom fail in striking the edge of a penknife stuck on the back of a chair. The plants from which this poison is extracted are not known.

Berbice. Mr Bolingbroke states, that the negro population of Berbice was doubled within ten years after it came into possession of the English; and that, in 1805, it amounted to about 40,000, besides 1000 free people of colour, and 2500 whites. From the papers, relative to the British West Indies, ordered by the House of Commons to be printed in 1815, it appears that, in October 1811, the population of Berbice must have decreased very considerably, if Mr Bolingbroke's estimate be correct; since, at that time, it consisted of

		Population	
Whites	- - - -	550	
Coloured	- - - -	240	
Blacks	- - - -	25,169	
Total		25,959	

A capitation-tax on the white and black inhabitants, an excise on every fifty pounds of sugar made, a weighage-toll of about 2 per cent. on all imports and exports, and a tonnage-duty of three florins per last on the burden of ships, are the principal sources of the revenue of the colony. In October 1811, there was only one private dwelling hired as a church for the use of the Dutch. The salary of the curate was 7000 stivers, that of the clerk and sexton 500 each, and that of the churchwarden 375. These sums were raised by a tax of one stiver per acre, with the exception of the Coromantine coast of the colony, which, in the return to Parliament, is represented as consisting of 80 estates, at 500 acres each.

The imports and exports were,—

	Imports.	Exports.	Exports and Imports.
1809,	L. 193,663	L. 49,662	
1810,	191,566	51,785	

In the years ending the 5th of January, there were imported into Great Britain from Berbice, of rum,—

	1810.	1811.	1812.	1813.
Gallons,	20,355	6193½	1866	23,139

And, in the year ending 5th January 1813, there was imported of sugar 9084 cwts. In 1809, the exportation of cocoa from the colony amounted to 17,665 cwts. and, in 1810, to 22,582 cwts. In the former year, the exportation of cotton was 1,874,195 lbs.; and, in the latter year, 1,656,057 lbs.

The colony of Berbice was founded in the year 1626, by a merchant of Flushing, to whose family, in 1678, it was granted as an hereditary fief. Three-fourths of it, however, were, not long afterwards, given to Van Hoorn and Company, in consequence of their discharging a heavy contribution levied on the colony by some French privateers. The new proprietors being allowed by the Dutch East India Company to import a certain number of negroes annually from Africa, and obtaining other privileges,

Berbice
Berkshire.

greatly extended the cultivation of sugar, cocoa, and indigo; but they were restricted from exporting the produce of their plantations to any part not within the province of Holland. In 1768, an insurrection happened among the slaves of Berbice, which was quelled chiefly by the assistance of the Indians, and the English from Barbadoes. In 1796, the colony capitulated to the British; but it was restored to the Dutch by the peace of Amiens. In 1803 it was again reduced, and its possession was confirmed to Britain by the peace of Paris. In consequence of the Lords of the Treasury learning that the loss of slaves on the Crown estates from the year 1803 to 1810, had been at the rate of 26 *per cent.* they appointed, in 1811, commissioners for the management of these estates, who were especially directed and empowered to maintain and protect the negroes, and to reward and encourage industry among them.

By an act of the British Parliament, passed in the 56th of George III. (1816), cap. 91, Berbice is placed on the same footing in relation to the regulations of trade, as the British West India Islands. The subjects of the King of the Netherlands, who are proprietors in Berbice, may import into it from the Netherlands the usual articles of supply for their estates, but not for trade;—wine imported for the use of their estates, to pay a duty of 10s. *per ton.* The Dutch proprietors may export their produce, but not to Britain; both exports and imports to be in ships belonging to the Netherlands,—the duties to be the same as those payable by British proprietors.

See Pinckard's *Notes on the West Indies*, 2d edition, Vols. I. and II.—Bancroft's *Essay on the Natural History of Guiana*.—Bolingbroke's *Voyage to Demerary*.—Tuckey's *Maritime Geography*, Vol. IV.—Baron Sack's *Account of Surinam*. (c.)

BERKSHIRE. As the article on this county, in the original work, is inaccurate and imperfect, nearly in the same respects as we have remarked the account of **BEDFORDSHIRE** to be, we shall follow the same plan here, as we did in the supplementary article on that county.

Extent and
Boundaries.

This county extends from 51.19 to 51.48 north latitude, and from 0.34.30 to 1.43 west longitude. In shape it is very irregular, the whole northern side being figured by the windings of the Thames, which, taking a southern course from Oxford, almost cuts this county asunder at Reading, and renders its whole western part much broader than its eastern. A part of Wiltshire, detached at a considerable distance from the rest of that county, lies in the neighbourhood of Woking and Reading, surrounded by Berkshire; and two Berkshire parishes lie on the north side of the Thames, surrounded by Oxfordshire. It is bounded on the north by Buckinghamshire and Oxfordshire, from which it is separated by the Thames; on the east by Surrey; on the south by Hampshire; and on the west by Wiltshire. At the north-west corner, it just touches upon Gloucestershire. Its greatest length, from Old Windsor to the county cross, near Hungerford, is 42 miles. Its greatest breadth from Witham, near Oxford, to the borders of Hampshire, south of Newbury, 28½ miles; and its narrowest, from the Thames by Reading, to the borders of Hampshire, in a direct south line, only

VOL. II. PART I.

7 miles. It is 207 miles in circumference. The area assigned to it in the original work is much too large. According to the agricultural report, the number of acres in it is only 438,977. According to the returns respecting the poor-rates, 476,170; and, according to Dr Beeke, 469,500.

The chalk stratum crosses quite through the whole of this county, but it is only in the western part of it that it is so elevated as to possess the name and character of Downs, and to be chiefly used as a sheep-walk. The Thames, entering the chalk-hills at Streatley, crosses them obliquely from thence onwards, leaving their more elevated part on the north of the river in Oxfordshire and Buckinghamshire, so that the eastern part of that stratum in Berkshire, is sufficiently covered with soil to be used in tillage-husbandry. To the south of the elevated part of the chalk ridge is a vale, which, beginning about the middle of Wiltshire, continues almost in a straight line from thence to the Eastern Sea, having in it the Channel of the Kennet, from Hungerford almost to Reading, and that of the Thames from Bray in Berkshire to the sea. Besides the great chalk stratum of the kingdom, which crosses Berkshire, there is a line of moderately elevated hills, which extend from Oxford to Farringdon. The substratum of this line is, for the most part, calcareous stone, of various degrees of hardness; being part of the same stratum, which, with a few interruptions, crosses the kingdom in a north-eastern direction, from the west of Dorsetshire, nearly parallel to the great line of chalk, and a few miles distant from it. Gently descending from this elevated line of country, is the vale of Berkshire, which crosses the country from the parish of Shireham on the west, to Cholsey on the eastern boundary. Next to this vale on the south are the chalk-hills already mentioned. The natural divisions of the county, which are as follows, are strongly marked, as might appear from our account of its surface: 1. The vale, as it is emphatically termed, or the vale of Berkshire, or the White-horse Vale, which, crossing the country from Shireham to Cholsey, is bounded on one side by the Thames, and on the other by the White-horse hills, a continuation of the Chiltern range. 2. The Chalky-hills, which run nearly through the centre of the lower part of the county. 3. The vale of Kennet; and, 4. The forest, which nearly occupies the whole of the eastern part, commencing on the east of the Loddon, and extending the breadth of the county to Windsor.

The prevalent soils in this county are light and calcareous; the soil of the vale of Berkshire is a gray calcareous loam, probably of more tenacity than any other soil in the county; it is evidently formed by vegetable earth and chalk; of course easily cultivated at all seasons, and very productive. On the sides of the vale of Kennet is, for the most part, a reddish earth, more or less mingled with chalk and flints; in the vale itself, the prevailing soil is gravel, but with some very fertile corn-land, or deep loam, easily cultivated. The whole course of the river Kennet is through a bed of peat, from Hungerford to Reading. The mode and cause of the formation of this peat are very evident. In the town

M m

Berkshire. of Reading, the Kennet passes between two hills; and it would appear, that formerly the channel between them could not have been sufficiently low to carry the waters off, and prevent them from forming a morass in its whole extent, for about 25 miles above this obstruction. To the south of this river, near Hungerford, a tract of poor gravel and clay commences; at first, for several miles it is very narrow; but in the eastern part of the county it becomes very wide. It is everywhere ferruginous, and in most places very barren. The southern boundary of the county everywhere passes through this line of coarse land. In the forest division there is gravel, clay, and loam; the last in the centre, and the two former in the southern parts; the substratum of nearly the whole of Berkshire is calcareous.

Climate. The climate of this county is mild and dry, except on the elevated line of chalk, where it is rather cold and piercing. We are not aware of any meteorological observations that have been made in the county.

Rivers. The principal rivers are the Thames, the Kennet, the Loddon, the Ock, the Lambourn, and the Auburn. The Thames enters this county about a mile south from Lecklade, and forms its boundary during a course of more than 100 miles; in its progress watering the towns of Abingdon, Wallingford, Reading, Maidenhead, and Windsor, besides several villages; it is navigable as high as St John's Bridge, near Lecklade. In its course through Berkshire, it produces pike, trout, and various other common fish, besides carp and tench, which are supposed to be brought thither by floods. The Kennet, having divided this county from Wiltshire for about two miles, enters it at Hungerford. At Newbury, where it is joined by the Lambourn, it becomes navigable, and flowing thence through rich meadows to Reading, it there unites with the Thames. Its course through Berkshire is nearly thirty miles. The trout of this river have long been celebrated for their size and flavour; it produces also pike, perch, eels, cray-fish, chub, roach, and dace. The river Loddon, which rises near Aldershot in Hampshire, becomes a boundary between that county and Berkshire at Blackwater. After continuing so for eight miles, it enters Berkshire at Swallowfield, and falls into the Thames near Wargrave; its course in the county being about twelve miles. The Ock, which rises near Uffington, falls into the Thames at Abingdon; its pike are remarkably fine. The Auburn rises in Berkshire, but afterwards becomes a boundary between it and Hampshire; beyond Hede-end, it again enters the county, and falls into the Kennet a little below Wasing; its whole course is about seventeen miles. The Lambourn rises among the hills in the vicinity of the town of the same name, and, as has been already mentioned, falls into the Kennet near Newbury.

Canals. The Wiltshire and Berkshire canal commences on the banks of the Isis near Abingdon, and, passing through Wantage, Chippenham, and Mielksham, joins the canal from the Kennet to the Avon, at Trowbridge. From this canal, collateral cuts are made to Wantage, Calne, and Chippen-

ham. The Kennet and Avon canal begins a little above Newbury, and runs parallel with the Kennet to Kintbury, where it crosses the river twice. It afterwards crosses it in three other places during its course to the head of the river. From Crofton to Barbage it goes through a tunnel 2½ miles long. After crossing the Avon thrice, it proceeds by the side of it till the junction with it is completed. The entire length, from Newbury to Bath, is 60 miles; with 176 feet rise, and 369 feet fall.

This county does not produce many rare plants; **Botany.** among those which occur the least frequently are *Myrica gale*, sweet willow, Dutch myrtle; *Monotropa hypopitys*, bird's-nest; *Asarum Europæum*, asarabacca, found by Dr Abbot in the beech-wood between Henley and Maidenhead; *Antirrhinum monspessulanum*, growing abundantly on the chalky banks of Henley hill; and *Lycopodium selago*, and *L. inundatum*, fir club-moss, and marsh club-moss, in a bog on Upton Common. The **Newbury Peat.** probable origin of the peat found in the Vale of Kennet has already been noticed in our account of that river. It is found on both sides of the Kennet for several miles above and below the town of Newbury. The stratum lies at various depths below the surface of the ground, and varies in thickness from 1 to 8 or 10 feet; gravel is usually found underneath it. Horns, heads, and bones of various animals, have been found in it. According to the analysis of Sir H. Davy, it consists of

Oxyde of iron	-	-	-	48
Gypsum	-	-	-	32
Muriat of sulphur and potash	-	-	-	20
				100

The mineralogy of Berkshire presents very little that is interesting. Oyster-shells are found in the sand strata near Reading; and in one place in the vicinity of that town, a stratum of fuller's earth.

Landed property is very much divided in this county; the largest estate not exceeding L.10,000 **Landed Property.** per annum; and very few amounting to L.5000. Property is least divided in the lower part of Berkshire. By far the greatest portion of the land is freehold. Leases on lives, and leases renewable every seven years, are not unfrequent. A few estates are held by leases of 1000 years. The farms are very various in respect to size; but in general they are small. According to Dr Beeke, on the supposition that there are 469,500 acres in the county, they are distributed in the following manner:—

Arable land, about	-	-	255,000
Meadows and dairy land	-	-	72,000
Sheep walks	-	-	25,000
Other dry pastures, parks, &c.	-	-	30,000
Wastes, chiefly barren heaths	-	-	30,000
Woods, copses, &c.	-	-	30,000
Space occupied by buildings, fences, wood, rivers, &c.	-	-	27,500
			469,500

Berkshire. From this statement it will be seen, that a large proportion of the land in Berkshire is under the plough. Wheat and barley are very extensively cultivated, and are produced of the very best quality. The flour which comes to the London market from Reading and its vicinity is deemed little if at all inferior to that which is produced from the wheats of Essex and Kent; between 20,000 and 30,000 sacks are sent annually to the metropolis. The malt of Berkshire, particularly that made at Reading, Newbury, and Wallingford, is equally celebrated for its goodness; it is principally sent to London and Bristol. At Wallingford alone, upwards of 120,000 bushels are made annually. On the grass lands in the vale of White-horse, are many good dairy farms, on some of which peculiarly rich cheeses are made.

Sheep. The Berkshire breed of sheep are very similar in size, form, and qualities, to the breed of Dorsetshire and Wiltshire. Besides this native breed, there are kept on the sheep farms the Wiltshire, Dorset, South Down, and a few of the Bagshot-heath breed. The whole produce of wool in this county is estimated at 4150 packs. The swine of Berkshire have long been noted for the smallness of their bone and their disposition to fatten quickly. They are now common in most parts of the kingdom, and are generally preferred at the distilleries, being good either for pork or bacon.

Agriculture. The agriculture of this county presents nothing else peculiar or deserving of notice, except the Newbury peat, which, when burnt, affords an excellent manure, and is very extensively used as such, not only in this but in the neighbouring counties.

Woodland. The south and east sides of Berkshire have a large proportion of woodland; the most common kind of wood is hazel, occasionally mixed with oak, beech, ash, and alder. The chief quantity of timber is at the eastern extremity of the county, in and about Windsor forest, in the Vale of Kennet, and by the banks of the Thames. Windsor forest was formerly of much greater extent than it is at present. According to Norden's map of it, taken in the year 1607, its circuit was 77½ miles, exclusively of that part of it which extended into Buckinghamshire. The present circuit of it, according to Rocque's map, is about 56 miles; but it will probably be soon much lessened, in consequence of the act of Parliament lately passed, by which commissioners are appointed to dispose of parts of it to the proprietors of neighbouring lands. Windsor great and little parks are in the forest. The former is embellished with some rich forest scenery. In it his Majesty had two large farms, one of which was conducted on the Norfolk, and the other on the Flemish system of husbandry. On the south-east side of Windsor little park was formerly a venerable tree, immortalized by Shakespeare, and since known by the appellation of Herne's Oak.

Manufactures. Berkshire was formerly one of the principal seats of the clothing-manufacture, which flourished particularly in the towns of Abingdon, Newbury, and Reading. In the middle of the seventeenth century, this manufacture was carried on to a considerable extent; but it declined soon afterwards, and for several

years has been wholly discontinued. In the vicinity of Newbury there is a large paper-mill; and in the town itself, a small manufactory of serge. There is another paper-mill at Bagnor; a manufacture of sacking at Abingdon, and a few other trifling manufactures in other parts of the county. The only one, however, which deserves particular notice, is the copper manufacture at the Temple Mills, in the parish of Bisham. In the early part of the last century, when they were employed for making brass and copper pans and kettles, they were known by the name of Bisham Abbey Battery Works. The manufactures now carried on at these mills are confined to the rolling of copper sheets, for various purposes; the rolling of copper bolts, for the navy and merchant service, and the hammering out copper pans and bottoms for distilleries. During full employment, from 600 to 1000 tons of copper are manufactured here. These mills are said to be the most powerful and complete in the kingdom.

There are many very great markets in Berkshire; Abingdon, Reading, Newbury, Wallingford, and Windsor, have great corn-markets. Isley is celebrated for its sheep-market, which is supposed to be the largest county market in England; it commences on the Wednesday in the Easter week, and continues to be held every alternate Wednesday till Midsummer; 20,000 sheep have been sometimes sold in one day; the annual average is upwards of 250,000, comprising lambs. Oakingham market is remarkable for its abundant supply of poultry, which is principally bought for the supply of the metropolis. At Farringdon is the principal market for bacon and hams; 4000 swine are said to be slaughtered annually here, between November and April, for the supply of London and Oxford.

Berkshire affords many specimens of Saxon architecture, the most remarkable of which are Avington Church, and the Nave of Windsor Church; the churches of Uffington, Englefield, and Farringdon, and the Chapel at Little Farringdon, exhibit some striking specimens of the early Gothic. One of the most complete and splendid specimens of the later style of Gothic architecture, is St George's Chapel at Windsor.

In the year 1776, the poor-rates of this county amounted to the sum of L. 39,933, 9s. 3d.; in the year 1783, they had increased to L. 49,866, 10s. 8d.; and in the year 1803, to L. 96,860, 19s. 10½d.: in this year the rate was at 4s. 11d. in the pound. Of the sum thus collected, L. 82,604 was expended in the maintenance of the poor; there were relieved, in and out of workhouses, 22,588 poor people, at the rate of L. 3, 12s. 10d. annually, for each person relieved. The number relieved in the workhouses was 1169, at the rate of L. 12, 6s. 5½d. per head; the number relieved at their own houses was 21,419, at the rate of L. 3, 2s. 10½d. per head. The total money raised by rates was 17s. 9d. per head, on the population at that time. Twenty-one persons in a hundred were relieved. There were 47 *Friendly Societies*, containing 2843 members; and there were 306 children in the Schools of Industry. By the last return to Parliament, 192 parishes in Berkshire

Berkshire (31 not having made any return) paid, in the year ending the 21st of March 1815, L. 125,710, Os. 4½d. for poor's-rates, and other parochial rates.

Population. The population of this county, at the time of the Norman survey, amounted to between 40,000 and 50,000. In the year 1700, it was estimated at 75,000. The number of inhabited houses, in 1800, was 20,573, of uninhabited houses 622, and of inhabitants 109,215. Of these 52,821 were males, and 56,394 females; 88,155 were chiefly employed in agriculture, and 16,921 in trades, manufactures, or handicraft. In 1811, the number of inhabited houses was 22,104; of families inhabiting them, 24,051; houses building, 129; uninhabited, 563; families employed in agriculture 13,409, on land, the annual rent of which was L. 407,186; families employed in manufactures and trade 7584, the amount of their annual profits being L. 272,582; families not included under these two heads 4058; males 57,360 and females 60,917. Total population 118,277. The number of people to a square mile was 744; the annual proportions of baptisms were one to 34 persons; of burials, one to 53; and of marriages, one to 144.

Historical Notices. During the civil war in the seventeenth century, this county was frequently the scene of action between the contending parties. In September 1643, the first battle of Newbury was fought, in which the celebrated Lord Falkland lost his life. In October 1644, a second battle was fought near Newbury; in each of them, both parties claimed the victory.—See Mavor's *Agricultural Report of Berkshire*; *Beauties of England and Wales*, Vol. I.; Lyson's *Magna Britannia*; Smith's *Map of the Strata of England, and Memoir*.

BERTHOUD (FERDINAND), Chronometer-maker to the French Admiralty, member of the Institute of France, and of the Legion of Honour, was born in the county of Neufchatel in 1727. His father's profession was that of architect, and the son was intended to be bred to the church, but, having shown a taste for clock-work, an experienced workman in that art was got to instruct him in its principles, and young Berthoud was afterwards sent to Paris to improve in the knowledge and practice of the art he had thus commenced. He settled in Paris in 1745, and applied himself to the making of chronometers, an art which was then in its infancy. A chronometer is an accurately made watch, whose chief peculiarity consists in a piece of mechanism intended to render the number of vibrations of the balance equal in equal times, at all the degrees of temperature to which the instrument is exposed; and the chronometer being a portable instrument, which can be used on ship-board, is by this mechanism made to move at a constant rate;—say at the rate of mean solar time, so that it shows what hour it is at the meridian of Greenwich, if the chronometer, at the commencement of the voyage, was set to Greenwich time, whilst the observation of the height of the sun or of a star gives the hour, angle, and the hour at the place where the ship is: the difference between these two times is the longitude of the ship. Fleurieu and Borda, by order of the French Government, made a voyage from La Rochelle to

the West Indies and Newfoundland, for the purpose of trying the chronometers of Ferdinand Berthoud, and found that they gave the longitude with only a quarter of a degree of longitude of error, after a cruize of six weeks. Satisfactory results were also obtained from his chronometers in the expedition of Verdun, Borda, and Pingré, which was appointed to try them, together with those of Le Roy. An account of this expedition is published.

Sully, an English watch-maker established in Paris, was the first who, in that city, attempted the construction of chronometers for finding the longitude; this he did in 1724. In 1736, the chronometers of the English artist, Harrison, were tried at sea. In France there were no chronometer-makers of note, from the first attempts of Sully, till Pierre le Roy and Ferdinand Berthoud, between whom there was some discussion about the priority of their discoveries and improvements. Ferdinand Berthoud's chronometers were long the most esteemed of any in France. Louis Berthoud, the nephew and successor of Ferdinand, has improved upon the machines of his uncle, and has made them generally of a smaller size, so as to become more portable. And many farther improvements have been made by the English chronometer-makers.

Ferdinand Berthoud was regular in his habits of life; he retained the use of his faculties to the last; and died, of hydrothorax, at his country-house, in the Valley of Montmorency, in 1807, having attained the age of 80. The principal published works of Ferdinand Berthoud are, *Essai sur l'Horlogerie*, 1786, 2 vols. in 4to; *two Tracts on Chronometers*, 1773; *De la Mesure du Temps*, 1787, in 4to; *Les Longitudes par la Mesure du Temps*, 1775, in 4to; *a Tract on Chronometers*, 1782, in 4to; *Histoire de la Mesure du Temps par les Horloges*, 1802, 2 vols. in 4to; *l'Art de conduire et de régler les Pendules, et les Montres*, 1760, in 12mo. In this tract directions are given for regulating clocks and watches suited to general readers; it has gone through several editions.

BERWICKSHIRE, a county in the south-east Situation of Scotland, bounded by East-Lothian on the north, the German Ocean on the east, Mid-Lothian on the north-west, Roxburghshire on the west and south-west, and by the Tweed, which separates it at first from Roxburghshire, and afterwards from England, and by the township of Berwick on the south and south-east; is situated in the 56th degree of north latitude, its central parts two degrees west from London; and contains 446 square miles or 285,440 acres, Extent of which more than a third is cultivated, or fit for cultivation.

It has usually been described as consisting of Divisions. three great divisions, Lammermoor, Lauderdale, and the Merse, of which the boundaries are by no means accurately defined (see article in the body of the work); but for every useful purpose, Lauderdale may be held as included in the other two divisions, and the greater part of it as belonging to Lammermoor. This mountainous district, on which Berwickshire meets with East-Lothian, commences at St Abb's Head on the north-east of the county, and passes into Mid-Lothian on the north-west. That

Berthoud
Berwickshire.

Betel. BETEL, a substance compounded of different ingredients, which is chewed in the east in the same way as tobacco is used in other parts of the world, but to much greater extent. All individuals, without exception of age or sex, begin at an early age to accustom themselves to betel, and it gradually becomes an article of such necessity, that those acquainted with the usages of the eastern nations affirm, they would more readily dispense with their ordinary quantity of food than with it. Europeans also, who have resided long in Ceylon or India, contract the same habit, and enjoy chewing of betel equally with the natives. Betel, or *pawn*, as it is denominated in Bengal, consists of part of the fruit of the *areca* palm, wrapped in the leaves of a kind of pepper plant called *betel*, smeared with a little shell lime; and its name betel-nut is thence derived.

Its universal consumption in the East. The areca palm is a tree growing 40 or 50 feet high, with a straight round stem six or eight inches in diameter, covered with a smooth ash-coloured bark, marked with parallel rings. All the leaves, which are only six or seven in number, spring from the top; they are six feet long, declining downwards from a stalk of considerable length. The fruit or nut is covered with a green shell or skin, thin, brittle, and of the consistence of paper; it is of an oval shape, the size of a small egg, and resembles a nutmeg despoiled of its husk. When ripe, it appears in clusters of a reddish colour, forming a beautiful contrast with the vivid green of its leaves, and then falls off to sow itself in the ground. The betel plant is a species of vine, bearing a leaf, somewhat resembling ivy; it is called *Piper betel* by botanists, and is of the same genus as the *Piper nigrum* of Linnæus. Its culture, which is carefully attended to, is managed in the same manner. Poles are planted in the earth, around which the betel twines itself, and as it runs up, the poles acquire greater height also. It is a creeping plant, seeking support from stronger vegetables, but it is said not to be destructive of them, like some other plants of a similar nature. Particular regard is paid to the cultivation of areca and betel throughout the countries of which they are natives, as we shall afterwards explain. Some years ago, it was found, on enumeration, that the number of trees, probably meaning the areca only, in Prince of Wales's Island, amounted to 342,110. The lime used with the nut is called *chunam*, and is obtained from the calcination of shells, as producing the finest kind. But the fresh nut must be avoided; it then contains a white viscous matter, insipid to the taste, and occasioning delirium, like ebriety from wine, but losing this property when dried; and it is employed either boiled or raw. The latter has undergone no change; the former is cut in slices, boiled with a small quantity of *terra japonica*, and then dried. Betel is compounded, therefore, of these three substances, with some additions or variations, according to the customs of the place where consumed; such as cardamoms, and coarse pounded tobacco, by persons of more depraved taste. The union of the three ingredients is supposed to correct the effects which each would produce singly; the nut improves the bitterness of the leaf, and the lime prevents any injury to the stomach. When combined, the first

consequences are reddening the saliva, giving a bright hue to the lips; and, in progress of time, the teeth are rendered quite black. The saliva, however, will not be tinged, if the *chunam* be omitted; and its pernicious operation on the enamel of the teeth may be averted, by rubbing them with a preparation whereby they are coated with a black substance that does not readily yield to any dentrifice, and preserves them from corrosion. Its medicinal effects are the dispelling of nausea, exciting an appetite, and strengthening the stomach. It possesses nutritious and enlivening qualities, which render it particularly acceptable to its consumers. The *terra japonica*, above alluded to, is not a universal ingredient; it is used only in certain countries, and is generally supposed to be a preparation from the areca-nut itself. It consists of two varieties, the one very astringent; the other less so, and rather sweet, which is preferred by the betel-eaters. To obtain the former, the nuts are taken from the tree, and boiled some hours in an iron vessel; they are then removed, and the water remaining is inspissated by continual boiling. The nuts being dried, undergo a second boiling, and, having been taken out, the water is also inspissated, whereby the best *terra japonica* is obtained. The nuts are then dried, cut in equal halves, and sold. Or it is obtained by inspissated decoctions of the wood of the keira tree, or *Mimosa catechu*. A great quantity of this substance is made in the Mysore, and some of inferior quality in Bengal. Probably it is something of this same kind that is prepared in Sumatra, under the name of *catacamber*, and chewed along with betel to give it an additional flavour.

Betel is not only used as an article of luxury, but as a kind of ceremonial which regulates the intercourse of the more polished classes of the east. When any person of consideration waits on another, after the first salutations, betel is presented as a token of politeness: to omit it, on the one part, would be considered neglect, and its rejection would be judged an affront on the other. No one of inferior rank should address a dignified individual without the previous precaution of chewing betel; two people seldom meet without exchanging it; and it is always offered on the ceremonious interviews of public missionaries. In some countries, it is not uncommon for the guest, who receives the betel from his host, to pass it between his thumb and fore-finger, and apply his own *chunam*, which never gives offence; and is thought to have originated in guarding a stranger against the insidious conveyance of poison, formerly too frequently practised in destroying persons who were obnoxious. Philtres or amatory charms are still conveyed along with the *chunam*, which are conceived to consist of some powerful stimulant. Mahometans abstain from this indulgence during the fast of Ramadan, though possibly not in every country, as it would be too great a privation; and the use of it is so interwoven with the existence of the natives of the warmer climates, that females of the higher ranks are said to pass their lives in doing little else than chewing betel. When the Cingalese retire to rest at night, they fill their mouths with it, and retain it there until they awake. According to

Betel. Knox, who passed many years in captivity on the island of Ceylon, most people going abroad carry a small box of gold or silver, containing the ingredients for compounding betel; and the poor keep a constant supply about them in purses of coloured straw, securely lodged in a fold of their garments. The stand or box containing it is often the subject of elegant workmanship; it consists of silver, gold, or tortoiseshell, and forms a piece of ornamental furniture in the houses of the wealthy. It is sufficiently valuable to constitute a present between sovereigns.

Culture.

Extensive gardens for cultivating betel are formed in different parts of India. The soil most favourable for the palm is a black mould on a substratum of limestone, or intermixed with calcareous nodules. Here it is planted in rows, and carefully manured and watered, during several years. It begins to bear from the eighth or tenth to the fifteenth year, and remains in perfection for thirty years; soon after which, it either dies or is cut down. Some, however, continue producing fruit from the fiftieth to the seventieth, or even the hundredth year; but it gradually declines both in quantity and quality. It appears that a very fertile tree produces, at an average, 857 nuts, and an ordinary one 600; but not everywhere, as there are trees affording no more than 200. The betel-leaf is either cultivated in separate gardens, where a red stony soil on the side of a rising ground is preferred, and plantains or bamboos planted along with the vines, which are arranged in trenches, to support them as they grow; or when an areca plantation is formed, and the palms are fifteen years old, cuttings of the vine are planted near the roots, and trained up to the trees. In twelve or eighteen months, the leaves of the vine are fit for sale, and in three years they are full-sized; but in another year they die, when all must be removed, and young plants immediately substituted for them. We do not know whether their duration is never longer; but in the southern parts of Canara in India, the gardens require renewal every four years, and in eighteen or twenty the soil is considered to be exhausted. These gardens are always surrounded by a hedge; sometimes the cultivators are annoyed with the depredations of squirrels and elephants. The crop of the areca is produced during three months; and the nut being pulled, is cut into seven or eight pieces, and piled up in a heap; then the same quantity of it and *terra japonica*, together with 100 leaves of betel-leaf, are beat together with water, and the juice strained into a pot. This is mixed with a decoction of the bark of the *Mimosa Indica* and water, and the nuts from the whole heap successively boiled in it. They are then exposed to be dried in the sun.

Commerce.

Betel is a very considerable article of traffic in India and China; and, indeed, throughout Asia. In the British settlements of Bombay, Madras, and Bengal, the value of the imports amounted in a single year to L. 188,836; and, if the quantities consumed throughout the East are taken into view, it will appear surprising how they can be obtained. But, owing to the constant and extensive demand, the plants affording the necessary ingredients are

carefully cultivated; and multitudes are employed and subsisted in the production of this Eastern luxury. Bettinelli (s.)

BETTINELLI (XAVIER), one of the most celebrated Italian literati of the eighteenth century, was born at Mantua, the 18th of July 1718. After studying under the Jesuits in his native city and at Bologna, he entered in 1736 upon the noviciate of this society. He then undertook a new course of study; and afterwards taught the belles-lettres, from the year 1739 to 1744, at Brescia, where the Cardinal Quirini, Count Mazzuchelli, Count Duranti, and other scholars, formed an illustrious academy. He there began to distinguish himself by some pieces of poetry, composed as scholastic exercises. Being sent to Bologna to pursue his divinity, he continued, at the same time, to cultivate his poetical talent, and wrote also, for the theatre of the college, his tragedy of *Jonathan*. The number of learned and literary persons collected in this city exceeded by far what he had met with at Brescia. The *Institute*, recently founded by the Count Marsigli, the Clementine Academy of Design, the School of the astronomical poet Manfredi, the growing reputation of his ingenious and learned pupils, Zanotti, Algarotti, and others, at this time fixed the attention of the literary world on Bologna. It was in the midst of this society, to which he was admitted, that Bettinelli completed his education, and attained the age of thirty. He went in 1748 to Venice, where he became Professor of rhetoric. He left it for various missions, and returned to it again often. We may see by his epistles in free verse (or *sciolti*), that he was connected on friendly terms with all that this city and state could boast most illustrious. He was destined by the Superiors of his order for the oratorical department; but the weakness of his chest compelled him to relinquish it. The superintendence of the college of nobles at Parma was entrusted to him in 1751; he principally directed the studies of poetry and history, and the entertainments of the theatre. He remained here eight years, but not without visiting, at intervals, different cities of Italy, either on the affairs of his order, or for pleasure, or for health. In 1755, he undertook a longer journey, traversed a part of Germany, proceeded as far as Strasburg and Nancy, and returned by way of Germany into Italy; taking with him two young princes, sons or nephews of the Prince of Hohenloe, who had requested him to take charge of their education. He made the year following another journey into France, along with the eldest of these two young Princes, and lodged, while at Paris, at the College of Louis-le-Grand. It was during this excursion that he wrote the famous *Letters of Virgil*, which were published at Venice with his *sciolti* verses, and those of Frugoni and Algarotti. The opinions, and we may add without much hesitation, the literary heresies, maintained in these letters against the two great luminaries of Italian poetry, and particularly against Dante, created him many enemies, and, what was still more unpleasant to him, embroiled him with Algarotti. Willing to know something more of France than Paris, he made several excursions.

Bettinelli. sions into Normandy and other provinces; he went also into Lorraine, to the court of King Stanislaus; from thence he proceeded to Lyons, and from thence to Geneva. Soon after his arrival he went to visit Voltaire. This celebrated writer sent to his inn an edition of his works, upon which he inscribed this stanza, in allusion to Bettinelli's *Letters of Virgil*:

Compatriote de Virgile,
Et son secretaire aujourd'hui,
C'est a vous d'ecrire sous lui;
Vous avez son ame et son style.*

From Geneva, where he consulted Tronchin the physician, Bettinelli proceeded to Marseilles, from thence to Nismes, and returned by Genoa to Italy and Parma, where he arrived in 1759. The same year, he took a journey to Venice, and afterwards to Verona, where he meant to settle. He resided here till 1767. Having resumed the occupations of preaching and teaching, he, according to the Chevalier Pindemonti, in his *Poesie campestri*, converted the youth to God in the church, and to good taste in his own house. He afterwards lived for some years at Modena, and he had just been appointed professor of rhetoric there, when, in 1773, the order of Jesuits was abolished in Italy.

He then returned into his own country, where he resumed his literary labours with new ardour. He there published several works, and regretting, as it appears, that he had written so much in his life without having been able, till then, to write anything to please the women (perhaps in consequence of the habit which he wore), he determined to make up for lost time, by publishing, one after the other, his *Correspondence between two Ladies*—his *Letters to Lesbia on Epigrams*—his *Letters on the Fine Arts*—and, lastly, his *Twenty-four Letters on Love*. These he published in 1796, when the war raged in all parts of Italy, and when the siege laid by the French to Mantua compelled him to leave it. He retired to Veroua, and there formed the most intimate friendship with the Chevalier Hippollito Pindemonti, notwithstanding the disproportion of their age. In 1797, after Mantua had surrendered, he returned there. Though nearly eighty years old, he resumed his labours and his customary manner of life. He began, in 1799, a complete edition of his works, which was finished at Venice, in 24 volumes *duodecimo*. Arrived at the age of ninety years, he still retained the gaiety and vivacity of his mind, and died the 13th of September 1808, after fifteen days of illness, with the firmness of a philosopher, and the sentiments of a believer. Without giving a list of all his works, or specifying the separate editions, it will be sufficient to refer to them in the order in which they are placed in this last edition.

1. *Ragionamenti Filosofici, con Annotazioni*. These philosophical discourses, which occupy the two first volumes, form a system of religious morality, in which the author endeavours to exhibit man under

all his relations, and in all states, following the order of the sacred writings, and treating, first, of man as created,—as reasonable,—as lord of the other creatures,—and in all the different states of solitude, society, innocence, error, repentance, &c. He only finished ten of these discourses. The notes are themselves little philosophical treatises,—On Beauty in general,—On Beauty of Expression,—On Physiognomy, &c.

2. *Dell' Entusiasmo delle Belle Arti*, 2 volumes, in three parts, of which the last is an appendix to the two others, and treats of the history of enthusiasm in different nations, and the influence which climates, governments, and all the modifications of society, have had on enthusiasm. In the two first parts, the author, who was not very subject to enthusiasm, sometimes writes a little obscurely on it, becomes turgid when he endeavours to be sublime, and remains a stranger to the warmth which he affects.

3. *Dialoghi d' Amore*, 2 volumes. The object of the author is to point out the influence which the imagination, vanity, friendship, marriage, honour, the love of glory, the study of the sciences, and fashion, have on the passion of love; and afterwards to trace the influence which it exercises on the productions of the arts of genius, and of the dramatic art in particular. The last dialogue, which is entitled, *On Love and on Petrarch*, is followed by the *Eulogy of Petrarch*, one of the author's best pieces.

4. *Risorgimento negli Studj, nelle Arti e ne' Costumi dopo il Mille*, 3 volumes; a work regarded in Italy as superficial, but which, nevertheless, contains some enlightened sentiments, and in which facts are often presented under a philosophical point of view, which wants neither novelty nor justness.

5. *Delle Lettere e delle Arti Mantouane: Lettere el Arti Modenesi*, 1 volume,—almost entirely filled with anecdotes of literary history, tending to the glory of Mantua, the country of the author.

6. *Lettere dieci di Virgilio agli Arcadi*. 1 vol. These letters, which have been translated into French by M. de Pommereul, Paris, 1778, are, of all the works of Bettinelli, that which has made the most noise. They are followed in this volume by *Letters from an Englishman to a Venetian*, which treat somewhat vaguely on different topics of literature.

7. *Italian Letters from a Lady to her Friend on the Fine Arts*, and *Letters from a Friend, copied from the Originals*, 3 vols. of which the letters on the fine arts occupy only the first.

8. *Poetry*, 3 volumes, containing seven small poems, sixteen epistles in easy verse, sonnets, canzonets, &c. Without ever showing himself a great poet, the author is always elegant and ingenious. These three volumes are preceded by a well-written discourse on Italian poetry. Several of the epistles and smaller poems are seasoned with attic salt. Such is the poem in four cantos entitled, *Le Raccolte*, in which Bettinelli very happily turns into ri-

* "Fellow-countryman of Virgil, and at present his secretary, it is for you to write in his name: you possess his soul and his style."

Bettinelli dicule those insipid collections of verses, which, in his time, appeared on every occasion in Italy.

Beykaneer.

9. *Tragedies*, 2 vols. These tragedies are *Xerxes*, *Jonathan*, *Demetrius Poliorcetes*, and *Rome Delivered*, a translation from Voltaire. Prefixed to them are some letters written in French, and a discourse in Italian, on the Italian tragedy. Some letters on tragedy, among others one on the tragedies of Alfieri, follow; and the second of these two volumes concludes with an eulogy on Father Granelli, a Jesuit, a preacher, and a poet, author of some tragedies, which are in much esteem, particularly for the elegance and beauty of the style.

10. *Lettre a Lesbia Cidonia sopra gli Epigrammi*, 2 vols. consisting of twenty-five letters, intermixed with epigrams, madrigals, and other light pieces, translated and original.

11. Lastly, an *Essay on Eloquence*, to which are added, some letters, discourses, and other miscellanies. It would be hazardous to pronounce a judgment on so great a diversity of productions, the author of which has so lately ceased to live and write. It should seem, in general, that he is distinguished more for wit and talent than for warmth and genius; that his writings contain literary opinions dictated by a taste not always correct, and which, having been publicly declared early in life, have often reduced the author to the unpleasant dilemma, either of retracting or of persisting, in spite of his better judgment, in what he must have perceived to be the errors of his youth; that his philosophy, of which the morality is pure, wants, when it aspires to metaphysical questions, both determinate principles and just conclusions, and is too often verbose and declamatory; but that, though his ideas are not always entitled to praise, his style is so almost always; that having been to blame, according to the Italian critics, in paying too little respect to the great writers of the fourteenth century, he has the merit of having remained constantly attached to those of the sixteenth, and to the authors who were his contemporaries, and who have taken him for their guide; and also of having defended to the last, both by his opinions and his example, the finest of the modern languages against the corruption which threatens, or rather which overwhelms it on all sides.—See *Bio-graphie Universelle*, Tom. IV. (z.)

BEYKANEER or BICANERE, a principality of Asia, situate in the north-west of Hindostan, the precise dimensions and limits of which are scarcely ascertained by modern geographers. It extends from about 27° 40' north latitude to 29° 45', and from 72° 10' to 75° 15' east longitude; and its superficial area probably amounts to about 17,000 square miles. It is bounded on the north by a country occupied by the Batties or people of Batneer; on the east by the territories of Hurriana and Shekhawuttee, in the province of Delhi; on the south-east by Jey-pour; on the south-west by Jesselmere; and on the west by Bahawulpoor. But these may be deemed obscure limits, for the countries named in them are scarcely better known than the subject of this article.

Descrip-tion.

A vast proportion of the soil of Beykaneer is a barren sandy desert, or a hard flat clay, sounding like

a board under horses' feet, and entirely destitute of inhabitants, water, and vegetation. Many miles are occupied in hills and valleys of loose heavy sand; the former from 20 feet to 100 in height, shifting their position and altering their shape according to the influence of the wind; and, during the heats of summer, clouds of moving sand threaten to overwhelm the traveller. Sometimes the phenomenon called *mirage* is exhibited in this desert, consisting of an optical illusion, whereby a spectator believes that he beholds a lake or a wide river well defined before him, reflecting surrounding objects, while there is nothing but a level uninterrupted surface in view.

Vegetation is exceedingly scanty throughout, except in a few patches, which are skilfully and industriously cultivated; and the whole country seems to depend on external supplies of grain. Nevertheless, in the midst of arid tracts, the water-melon, a juicy fruit, grows in profusion, attaining the remarkable size of three or four feet in circumference, from a stalk no larger than that of the common melon. The seeds are sown by the natives, and also grow wild, but it is difficult to account for such an enlargement of size with so little moisture. Water seems to be obtained only at an immense depth; the wells at Beykaneer are often from 300 to 345 feet deep, yet not above three feet in diameter; all are lined with masonry; and one of the most curious objects in the city of Beykaneer, is considered to be a well 300 feet deep, and 15 or 20 in diameter, worked by four pair of oxen drawing as many buckets of water. The water is always brackish, scanty, and insalubrious, and this, combined with the nature of the soil, principally occasions the prevalent sterility of this country.

The wild ass, remarkable for its speed and its shyness, is found here, sometimes solitary, but oftener in herds. At a kind of shuffling trot, peculiar to itself, it will leave the best horses behind. Antelopes are seen in some parts, also foxes, smaller than those of Britain, and the desert rat is in great numbers, occasioning serious inconvenience to equestrians from the holes it makes where the ground is sufficiently solid. Of domesticated animals, horses, bullocks, and camels, are in abundance; the last kept in great herds for various purposes. The horses brought from the vicinity of the Lacky Jungle, an adjoining district, where they are reared on excellent pasture and with the strictest attention, are much prized. But the original breed was greatly improved by the introduction of fine Persian horses, brought hither during the successive invasions of Hindostan by Nadir Shah, and other eastern potentates. At present they bear very high prices, some of them bringing even L. 250 Sterling, a large sum in a poor country. But some decrease in the extent and quality of the breed has lately resulted from the impolitic conduct of the officers of the Rajah of Beykaneer, by whom the owners are compelled to sell them at an undervalue. When purchased thus, the horses are sent on speculation to different parts of the Indian peninsula.

We are little acquainted with the manners and customs of the inhabitants of this country, otherwise

Beykaneer. than by their correspondence with those of the same tribes disseminated elsewhere in India. The natives are divided into two principal classes, Rajpoots and Jauts; the former the rulers, the latter the mass of the people. The Jauts are of small stature, black, ill-looking, and bear strong indications of poverty and wretchedness; the Rajpoots are stout and handsome, with Jewish features, of haughty manners, an indolent disposition, and greatly addicted to intoxication with opium. It is doubtful whether the Rajpoots of Beykaneer entertain those elevated and magnanimous sentiments so peculiar to their tribe, whether they are animated by that high sense of honour and impatience of indignity, which, united to the violence of their passions, lead to the most terrible catastrophes. When a man of rank finds himself beset by an enemy, from whom he has no chance of escape, he inquires whether, by surrender, he can preserve the honour of his family; should the answer be equivocal or unfavourable, he clothes himself in yellow, the symbol of despair, and repairing along with his nearest relatives to the apartments of the females, the whole are involved in promiscuous destruction; nor is it uncommon, on such occasions, for the women themselves to commit suicide. The Rajpoot then rushes furiously against his enemies, and though he should be successful and prevail over them, rather than survive his dire calamity, he plunges his sword in his own breast. The same sense of dishonour induces females of rank to deem themselves contaminated by the gaze of any man but their most intimate relatives; and it also leads them to ascend the funeral pile of their husbands, lest, by survival, they should lose the consideration of the world. The people of the East, while more placid and resigned to fate, are, at the same time, agitated by more acute and ungovernable passions than the inhabitants of the Western World: A Mahometan officer of high rank, who was hard pressed by a victorious enemy, approaching the place where his wife and daughter had sought refuge on the banks of a river, gave the following account of his conduct: "I leapt from my horse, and seizing each by a hand, rushed with them into the water up to their waists, and covered the rest of their persons with a cloth: I drew my sword to defend them with my life from further insult, and, happily for my honour, their faces were not seen by the eyes of a stranger." Of late the Rajpoots of Beykaneer have been accused of being cruel and treacherous.

Towns.

The population of this territory is altogether uncertain; but, from the scarcity of water, it is probably very much restricted. The inhabitants are dispersed in towns and villages, of which Beykaneer, near the southern frontier, in about 27° 55' north latitude, the capital, and Churoo, on the eastern frontier, are the chief. Beykaneer, surrounded by lofty white walls, strengthened with numerous round towers crowned by battlements, presents the imposing picture of a great and magnificent city in the midst of a wilderness. But, on entering the gates, the illusion vanishes; it proves to consist, for the most part, of huts built of mud, and painted red. Nevertheless, there are some high houses, several temples, and at one corner a lofty and fine

Beykaneer. looking fortress, a quarter of a mile square, environed by a wall 30 feet high, and a good dry ditch. The interior is a confused assemblage of towers and battlements, overtopped by houses, and it contains the royal palace, a curious old edifice. Churoo, independent of the suburbs, is above a mile and a half in circuit, and, although situate among sand-hills, has a handsome appearance. All the houses have terraces, and are built of a pure white limestone like those of Beykaneer. Villages are occasionally seen in the most dismal situations, to which their miserable aspect corresponds. They consist of a few round huts of straw, with low walls and conical roofs like little stacks of corn, and surrounded by hedges of thorny branches stuck in the sand. A modern traveller speaks thus, in describing the town of Pooggul: "If I could present to my reader the foreground of high sand-hills,—the village of straw huts,—the clay walls of the little fort going to ruins, as the soil which supported them was blown away by the winds, and the sea of sand which formed the rest of the prospect, he would probably feel, as I did, a sort of wonder at the people who could reside in so dismal a wilderness; and of horror at the life to which they seemed to be condemned." The city of Beykaneer is said to stand 219 miles north-west of Delhi, but its real position is south-west, and we conceive the distance to be not less than 260 or 280 miles. Fortresses are not so common in this territory as in a large portion of Hindostan, owing to the equality of the surface.

Scarcely anything definite can be said regarding the occupation and pursuits of the people in their trade and manufactures. Cattle of an inferior breed, and horses, are the only exports; rice, sugar, opium, and indigo, are obtained from the Punjab; salt from Samber; wheat from Jeypour; and spices, copper, and coarse cloth, are imported from Jesselmer.

Beykaneer is governed by a Rajah, who is a sovereign and independent prince, though he seems formerly to have been tributary to the monarch of Delhi; and even acknowledged the supremacy of Britain, when Delhi had fallen under a foreign power. He enjoys an absolute sway over the lives and property of his subjects, and maintains considerable state in his reception of strangers. His revenues do not exceed L. 50,000 *per annum*, though occasionally augmented to nearly double that sum by vexatious imposts on merchandize *in transitu*. Therefore, those caravans which were accustomed to take the route of this province from Surat to Tatta, a town on the Indus, follow another course, in order to avoid such exactions. The resources of Beykaneer are thus very small, which is not surprising, considering they are derived from a country that becomes an absolute desert even within a few yards of the capital. The Rajah's forces amount to 10,000 men, of whom 2000 are cavalry, and he has 35 pieces of artillery; all which troops are paid by assignments of land. Soorut Sing, the reigning Rajah, having profusely dissipated the treasure accumulated by his predecessors, became cruel and tyrannical. Oppressive exactions to relieve pressing necessities alienated the regard of his subjects, and an army of mercenaries became necessary to preserve his authority. He was suspected of poi-

Beykaneer
|
Bibliography.

soning an elder brother, and undoubtedly murdered the envoy of another prince passing through his dominions. Yet, being strict in his external devotions, and religiously abstaining from prohibited food, his people have admitted him to the character of sanctity. The sovereign of Beykaneer has to contend with many enemies, who, in their turn, are opposed by the most powerful obstacles. Water must be carried by an invading army; for the natives either poison the wells, fill them up, or cover them over in such a manner that they cannot possibly be found; and, besides, they mix arsenic with bread, which is insidiously disposed of in the hostile camp. Some years ago, George Thomas, a celebrated adventurer, who raised himself to the government of a neighbouring territory, invaded Beykaneer, and compelled the Ra-

jah to purchase peace with L.25,000. He also aided the Batties in expelling him, on occasion of an incursion he had made into their country. More recently, a war having commenced between the Rajahs of Joudpour and Jeypour contending for the hand of an eastern Princess, the interference of Soorut Sing excited the wrath of some of the competitors against himself. Five different armies invaded Beykaneer in 1808, when the Rajah filled up all the wells within ten miles of the walls of his capital. The contest was protracted for a considerable time, but we are unacquainted with its issue.

Beykaneer
|
Bibliography.

See Franklin's *Memoirs of General Thomas*.—Scott's *Memoirs of Eradut Khan*.—Franklin's *Tracts*.—Elphinstone's *Account of Caubul*. (s.)

BIBLIOGRAPHY.

THE branch of knowledge to which the term Bibliography is now universally applied, would certainly be more correctly designated by the word *Bibliology*. It was originally employed to denote skill in the perusing and judging of ancient Manuscripts; * but is, at present, appropriated to the Knowledge of Books, in reference to their Constituent parts, their Editions and different degrees of Rareness, their Subjects and Classes.

It is in France, Germany, and Italy, that this species of knowledge has been most largely and successfully cultivated; for though it will appear in the sequel, that Britain has produced some valuable works in this department, it will also appear, that our Bibliographical labours have been greatly surpassed by the Continental Nations. It is to France, in particular, that we are indebted for the most popular and useful treatises in Bibliography; but whilst we make this acknowledgment, in which all who have had any experience of their utility will concur, we must add, that some of her Bibliographers have lately fallen into a very extravagant mode of describing the nature and rank of this branch of Learning. They go so far as to represent it as a Universal Science, in whose ample range all other sciences, and all other kinds of knowledge, are comprehended. *La Bibliographie etant la plus étendue de toutes les sciences, semble devoir les renfermer toutes*, is the language of one; † *La Bibliographie est la plus vaste et la plus universelle de toutes les connoissances humaines*, is the language of another; ‡ though, nothing surely can be more preposterously illogical than to view it in this light, merely because it is conver-

sant about Books, and because Books are the vehicles of all sorts of knowledge. Yet this is the sole foundation that we can discover for these extravagant representations; which tend, as in all other cases of extravagant pretension, to bring ridicule upon a subject, that, were its nature and objects simply and correctly defined, could not fail to appear both useful and important. We have already stated, in a general way, what kind of knowledge of Books it is, to which the appellation of Bibliographical knowledge is applied; but, in order more fully to illustrate its nature and scope, as well as to point out its limits and its utility, we shall now endeavour to detail somewhat more particularly the chief objects of inquiry which it embraces.

It is the business of the Bibliographer, then, to trace the history of Books in regard to their forms and all other constituents, and, consequently, to trace the beginnings and progress of Typography. It belongs to him, in a particular manner, to mark the differences of editions, and to indicate that edition of every Book which is esteemed the most correct and valuable. In the case of Books published without the names of their authors, or under feigned names, it is his business to assign those names which the discoveries of Literary History may have furnished him. All remarkable facts attaching to the history of Books,—such as the number of their editions, their rareness, their having been condemned to the flames, or suppressed, belong to the province of Bibliographical inquiry. Further, every one who engages in any particular line of study, must of course wish to know what Books have been published in re-

* BIBLIOGRAPHE. C'est le nom qu'on donne à ceux qui déchiffrent les anciens manuscrits, et qui sont versés dans la connoissance des livres; mais aujourd'hui on donne ce nom spécialement à ceux qui connoissent les livres, et les éditions, et qui en font des catalogues. *Dictionnaire de Trevoux*, Tom. 1.

† See *Cours Elementaire de Bibliographie*, par Achard. *Introduit*.

‡ See *Dictionnaire de Bibliologie*, par Peignot. *Art. Bibliographe*.

Bibliogra-
phy.

gard to it, or in regard to any particular point that interests his curiosity; now, it is the business of the Bibliographer to furnish this most useful species of information: in other words, the compilation of Catalogues of the Books which have appeared in the various Branches of Knowledge, constitutes another grand department of Bibliography. It is by means of such Catalogues that, to use the words of Dr Johnson, "the Student comes to know what has been written on every part of learning; that he avoids the hazards of encountering difficulties which have already been cleared; of discussing questions which have already been decided; and of digging in mines of literature which have already been exhausted." (Preface to the *Catalogus Bibliothecæ Harleianæ*.)

Such is the outline of the principal objects and pursuits of the Bibliographer; and while it must appear abundantly evident that his Science, as it is called, has no pretensions to those lofty epithets upon which we have animadverted; it must, we think, be allowed by every one, that it embraces many curious, as well as interesting subjects of inquiry; and that it is calculated to afford very useful aids to every other species of intellectual occupation. This view of it will be fully confirmed by the details which we are to offer in the course of this article; in which we propose to point out the progress and best sources of information, in regard to all those departments of Bibliographical knowledge, to which we have alluded. In doing so, we shall divide the subject into such a number of heads, as shall appear best suited to the purposes intended.

L. Of the Constituent Parts of Books, and the Differences of Editions.

The history of the Materials employed to make Books, of the arts of Writing and Printing upon these materials, and of the Forms and Sizes in which they have appeared, all belong to this head of inquiry. Almost the whole of these particulars have furnished topics for much elaborate research; and some of them for speculations and disputes not yet likely to come to any satisfactory conclusion; but as our main object at present is, to indicate the inquiries which belong to the different departments of Bibliography, together with the best guides to information in each, our notices of these subjects here, must be limited to what is necessary for that purpose. Most of them, indeed, necessarily form the subjects of separate articles in other parts of an Encyclopædia.

Much curious learning has been exercised in describing the various substances used for writing, previous to the important discovery of the art of making Paper from *linen rags*. The precise era of this discovery is not known, nor are authors agreed as to the country in which it was made; but it seems to be ascertained, that this kind of paper was in general use in Europe before the end of the fourteenth century. *Cotton paper* had been in general use more than a century before; and though of greatly inferior quality, its introduction

Bibliogra-
phy.

was one of the most fortunate circumstances in the history of the arts; for parchment had become so scarce, that old writings were often erased, in order to apply the parchment to other purposes; and thus, by a metamorphosis of a singular and fatal kind, a Classic was sometimes transformed into a vapid homily or monkish legend. In this way, it is supposed, that some valuable works of antiquity have perished; and, indeed, there can be little doubt of this, when we consider the number of manuscripts that have been discovered, evidently written upon erased parchments. Upon some of them both writings remain legible, and, in this guise, some fragments of Cicero have lately been discovered. These twofold manuscripts are called *Codices Rescripti*. We shall quote from Mr Horne's *Introduction to Bibliography* (Vol. I. p. 115), an account of a *Codex Rescriptus*, discovered about twenty-five years since, at Dublin, by Dr Barret of Trinity College. "While he was examining different books in the Library of that College, he accidentally met with a very ancient Greek *MS.*, on certain leaves of which he observed a twofold writing, one ancient, and the other comparatively recent, transcribed over the former. The original writing had been greatly defaced, but, on close examination, he found that it consisted of the three following fragments: the Prophet Isaiah, the Evangelist St Mathew, and certain orations of Gregory Nazianzen. The fragment containing St Mathew's gospel, Dr Barret carefully transcribed, and it has been accurately engraved in fac-simile, and published by the order, and at the expence, of the University. The original writing, or *Codex Vetus*, Dr Barret, with great probability, assigns to the sixth century; the *Codex Recens*, or later writing, he attributes to the thirteenth."

That part of the history of Books which regards the various substances upon which they have been written, is compendiously, but learnedly, treated in the first volume of that very valuable work, the *Nouveau Traité de Diplomatique*, compiled by two Benedictines of the celebrated Society of St Maur. This work was published at Paris in 1750, in six volumes quarto. M. Peignot gives a complete list of separate works on this subject, in the introduction to his *Essai sur l'histoire du Parchemin et du Vêlin*, published at Paris in 1812.

The inquiry as to the *origin* of Writing, is a purely philosophical speculation; but the knowledge of the different kinds of writing peculiar to different ages, is a branch of the history of Books which belongs to the province of Bibliography, and upon which much information will be found in the learned work of the Benedictines of St Maur, just referred to. One of the best Books on this subject is Mr Astle's *Origin and Progress of Writing*; the first edition of which was published at London in 1784, and the second, with some additions, in 1803, both in one volume quarto. The chapters on the Transcribers and Illuminators, and the instruments, inks, and other matters which they made use of in their operations, will be found peculiarly interesting to the Bibliographer.

We are now so familiar with the wonders and glorious results of Printing, that it is only when we

Bibliography. look back into the history of the darker ages, that we are made fully sensible, of all the various advantages which it has conferred upon mankind. The mention of the *Transcribers*, that is, the class employed to copy Books, before the discovery of Printing, is well calculated to give rise to reflections of this kind. Their ignorance and carelessness were often the causes of much trouble and mortification to living authors, and of irreparable errors in the works of those who were dead. Petrarch, who flourished in the fourteenth century, has expressed himself in very moving terms, in regard to this double evil. "How shall we find out a remedy," says he, "for those mischiefs which the ignorance and inattention of the Copyists inflict upon us? It is wholly owing to these causes that many men of genius keep their most valuable Pieces unpublished, so that they never see the light. Were Cicero, Livy, or Pliny, to rise from the dead, they would scarcely be able to recognise their own Writings. In every page they would have occasion to exclaim against the ignorance and the corruptions of those barbarous Transcribers."* Upon the invention of Printing, the class of Copyists immediately took alarm, and exerted every means to extinguish an art which, whatever benefits it promised the rest of mankind, held out nothing but prospects of loss to them. They endeavoured, and their example is still steadily followed by other Crafts, to set up their own petty interests in opposition to the general good; and called upon their Governments to invest them with exclusive privileges, which all the great interests of society required to be done away. Thus, when Printing was introduced at Paris, the Copyists complained of the injury to the Parliament, and that body forthwith caused the Books belonging to the Printers to be seized and confiscated; but Louis XI. had the good sense to restore their property to these ingenious artists, and to authorize them to proceed in their laudable vocation. (Lambinet, *Origine de l'Imprimerie*.)

The question as to the *origin* of Printing, is of a complexion wholly different from that regarding the *origin* of Writing, as it turns entirely upon matters of fact; but it is not the less true, that this is a subject upon which opinions widely opposite are, to this day, entertained; for though this art, we mean the art of Printing with *moveable* types, was spread all over Europe within twenty years of the first discovery, it has unfortunately failed to record, in decisive terms, the name of the individual to whom the honour of the invention is due. The *place* where the discovery was made remains also a subject of doubt and contention. In Mallinkrot's work, *De ortu et progressu artis Typographicae*, published in 1640, he enumerates a hundred and nine testimonies in favour of Mentz, as the birth-place of the art; and since that time the number has been greatly augmented; yet the latest author who has resumed the controversy, declares decidedly in favour of Haerlem, which, in Mallin-

Bibliography. krot's day, ranked only thirteen advocates; and further, assigns the wreath which the supporters of Mentz have variously placed on the brow of Guttenberg, of Faust, and of Schoiffer, to Lawrence Coster, as its rightful owner.† All that we can do in this place, is to point out some of the most important works which have been published upon the origin and history of Printing, and which it may be necessary for the Bibliographer to examine, in order to enable him to judge of early editions; recommending those who wish to see a clear and compendious view of the various opinions which have been advanced upon this subject, to peruse M. Daunou's *Analysis* of these opinions, published in the fourth volume of the *Memoirs* of the Moral and Political Class of the French Institute.

The *Monumenta Typographica* of Wolfius, published in two thick octavo volumes, at Hamburg in 1740, contains a valuable and curious collection of treatises by various authors, and also of extracts, illustrative of the origin and early history of the art. Some of these pieces are in verse. Among several other elaborate tables, it contains one of all the authors, who, up to that time, had either directly or indirectly treated of the history, or of the mechanical part of Printing. Meerman's *Origines Typographicae* is one of the most instructive works as to the progress of the art. It is illustrated with various specimens of early printing, and fac-similes of the Books called *Block-Books*, printed by means of wooden-blocks. Meerman, who was a Lawyer, and author of many elaborate treatises in the Civil and Canon law, was born at Leyden in 1722, and died in 1771, six years after the publication of his *Origines*; in which he supports the pretensions of Haerlem as the birth place of the art, and of Lawrence Coster as its inventor, with great ardour and learning. Another work of curious research on the origin and first progress of Printing, is that of Prosper Marchand, originally a Bookseller at Paris, but whom the repeal of the edict of Nantz drove to Holland, where he employed himself till his death in 1756, in composing various works in Literary History and Bibliography. He makes Guttenberg the inventor of the art, and Mentz the place where he completed the invention; the first idea of it, however, having been formed by him, whilst he resided in Strasburg. This work, entitled, *Histoire de l'Origine et des premiers progres de l'Imprimerie*, was published in 1740. A valuable Supplement, in which some errors of Marchand are corrected, and some new views are advanced, was published by M. Mercier, Abbé de Saint Leger, in 1773, and republished in 1775. The author of the original work was not at all pleased with this Supplement, and he accordingly criticised it with great severity in a long letter addressed to the Editors of the *Journal des Savans*, where it was published. The opinion that Guttenberg conceived the first idea of the invention at Strasburg, and afterwards completed it

* Quoted in Lambinet, *Origine de l'Imprimerie*, Tom. I. p. 38, 39.

† See Otley's *Inquiry into the Origin and early History of Engraving*, cap. 3.

Bibliography.

at Mentz, is also supported by Lambinet, in his *Recherches, historiques, littéraires, et critique sur l'Origine de l'Imprimerie*, first published at Brussels in 1799; and republished in two volumes octavo at Paris in 1810, with the addition of M. Daunou's *Analyse des Opinions*, already mentioned. Besides the main subject of inquiry, M. Lambinet's work embraces various other objects of curious research,—the history of the substances employed for Books, of Inks, of Engraving in relief, of Block-printing, and of Stereotype Printing. Upon the history of Printing, we shall only mention further, M. Serna Santander's *Essai Historique*, prefixed to his *Dictionnaire Bibliographique*, to be afterwards more fully described; and the *Initia Typographica* of Professor Lichtenberger, published at Strasburg in 1811; in both of which, the claims set up for Coster are treated as founded on fables; Guttenberg being represented as the inventor of the art, and Mentz the place where it was perfected; and in both of which, there are ample details as to its progressive establishment in the other cities and countries of Europe.

Besides the information afforded in these General Histories, as to the progress of Printing throughout Europe, there are various Histories of its establishment in particular countries and places, which it will often be necessary for the Bibliographer to consult. One of the most valuable, particularly to the English Bibliographer, is Ames's *Typographical Antiquities*; which contains memoirs of our early Printers, and a register of their publications, from 1471 to 1600. The first edition, published in 1749, consisted of one volume quarto. Another edition, enlarged by Mr Herbert to three volumes quarto, was completed in 1790; and a third edition, illustrated with superb embellishments, and containing some valuable additions, by Mr Dibdin, is now (1817) in course of publication. The French, Germans, and Italians, particularly the latter, are rich in Typographical Histories of this description; but for accounts of them, we must refer our readers to Peignot's *Repertoire Bibliographique Universel*, where they are enumerated and described.

A knowledge of the different classes and bodies of Letter used by Printers is necessary to the accurate description of Books, and discrimination of editions. The Bibliographer must also be acquainted with the corresponding appellations assigned to the different bodies of letter by foreign Printers. Thus the form called *pica* by English Printers, is called *Cicero* by those of France and Germany, because Cicero's *Epistles* were printed in that type. The form called *paragon*, is the only one which retains the same name among the Printers of all countries. Upon all these points, Stower's *Printer's Grammar*, and Fournier's *Manuel Typographique*, may be consulted with advantage. The latter is rich in specimens very neatly executed. It consists of two octavo volumes published in 1764, to which the author, who was a Parisian Letter-founder, and

Bibliography.

Engraver of great ingenuity and taste, intended to have added two more, but was prevented by his death, which happened in 1768.

The Books of the Ancients were generally in the form of cylinders, made by rolling the joined sheets upon a stick, to the ends of which, knobs or balls were affixed, often richly ornamented; there being just as much foppery among the Collectors of ancient times, as to the matter of ornamenting their Books, as among the *Bibliomaniacs* of the present day. In the infancy of Printing, the sizes were generally folio and quarto; and some have supposed that no Books were printed in the smaller forms till after 1480; but M. Peignot instances many editions in the smallest forms, of an earlier date; as may be seen in the article *Format* of the Supplement to his *Dictionnaire de Bibliologie*. An accurate knowledge of the different forms of Books is necessary to the Bibliographer, as, without this, no Book can be correctly described; and however easy of acquisition this knowledge may appear, it is yet certain, that errors in this respect are sometimes committed even by experienced Bibliographers; and that doubts have been entertained as to the existence of editions, owing to their forms having been inaccurately described.* These mistakes generally proceed from this, that there are different sizes of paper comprehended under the same name. But the water lines in the sheets afford a test; as they are uniformly perpendicular in all folio and octavo sizes, and horizontal in all quarto and duodecimo sizes.

When Books have gone through more than one edition, various minute inquiries must often be made, in order to determine the respective merits of those editions. It is a principal object of the Bibliographical Dictionaries, to be afterwards mentioned, to point out the editions of important works, which such inquiries have ascertained to be the best. There are many particulars in which one edition may differ from, or excel another. There may be differences and grounds of preference in Size, in Paper, and in Printing. The Text of one edition may be more correct than that, either of a preceding, or a subsequent one. An author sometimes corrects errors, makes alterations, or introduces new matter when his work comes to be reprinted, thereby giving the edition so altered a decided superiority over its predecessor. One edition may differ from another by having Notes, an Index, or Table of Contents, which that other wants; or these accompaniments may themselves furnish grounds of preference by being superior in their kind in particular editions. Plates make great differences in the value of editions, and even in the value of Copies of the same edition. In the beautiful engraved edition of Horace by Pine, there is, in the copies first thrown off, a small error, which serves as a test by which Bibliographers immediately judge whether any copy has the best impressions of those elegant vignettes which illustrate that edition. The medal of Augustus in page 108 of the second volume, has, in the copies

* See Boulard, *Traité Elementaire de Bibliographie*, p. 38, 39.

Bibliography.

first thrown off, the incorrect reading *Post Est* for *Potest*; this was rectified in the after impressions; but as the Plates had previously sustained some injury, the copies which show the incorrect reading are, of course, esteemed the best. Mr Dibdin, in his Book called *The Bibliomania*, very absurdly points out this as an instance of preference founded on a defect; whereas the ground of preference is the superiority of the impressions, ascertained, without the necessity of any comparison, by the presence of this trifling defect. There are, sometimes, owing to particular circumstances, differences between Copies of the same edition of a work; and which, therefore, stand to each other in the same relation, as if there had been another edition with some variations. Walton's *Polyglott Bible* is a celebrated instance. The printing of that great work, for which Cromwell liberally allowed paper to be imported free of duty, was begun in 1653, and completed in 1657; and the preface to it, in some copies, contains a respectful acknowledgment of this piece of patronage on the part of the Protector; but in other copies, this compliment is expunged, and replaced by some invectives against the Republicans, Dr Walton having, at the Restoration, printed another preface to the copies which were undisposed of at that event.* The copies, with the original preface, are much rarer, and of course more prized, than those with the loyal one, which latter seems to have helped the author to the Bishopric he afterwards obtained.

II. Of Early Printed Books.

The productions of the Press, in the different countries of Europe, during the century in which Printing was invented, have engaged much of the attention of Bibliographers, and have been described in various works, compiled for that purpose. The first of those productions to which the name of *Books* has been applied, were printed, not with moveable types, but with solid wooden blocks; and consisted of a few leaves only, on which were impressed images of Saints, and other historical pictures, with appropriate texts or descriptions. These leaves were printed only on one side, and the blank sides were generally, though not always, pasted together, so as to look like single leaves. The ink used was of a brownish hue, and glutinous quality, to prevent it from spreading. These curious specimens of the infant art are called *Image Books* or *Block Books*. They have often been largely described, every particular concerning them being fondly cherished by Bibliographers. Their number is fixed by some at seven, and by others carried to ten; but there have been numerous editions of most of them; for they maintained their popularity long after the invention of the art of Printing, properly so called. One of the most celebrated is the *Biblia Pauperum*, consisting of forty leaves, printed on one side, so as to make twenty when pasted together; upon which, certain historical passages of the Old and New Tes-

tament are represented by means of figures, with relative inscriptions. It was originally intended, as its name imports, for the use of those poor persons who could not afford to purchase complete copies of the Bible. There is a copious account of all the *Block Books*, in Baron Heineken's learned work, *Idee générale d'une Collection complete d'Estampes*, published in 1771, in one volume octavo. Mr Dibdin's *Bibliotheca Spenceriana* contains fac-similes of the figures in several of them, as does also Mr Ottley's *History of Engraving*.

The first Book of any considerable magnitude printed with moveable metallic types, was the celebrated *editio princeps* of the Bible, printed at Mentz, between the years 1450 and 1455. It is printed in large, but handsome, Gothic characters, to resemble manuscript, having two columns in the page, and consisting in whole of 637 leaves, divided into two, three, or four volumes, according to the taste of the binder. (Santander, *Diction. Bibliog.* Tom. II.) The advance from the rude *Block Books*, of a few leaves, to this noble monument of early Typography, is great indeed; and it is impossible not to regret, that there should be still so much uncertainty as to the person whose ingenuity furnished the means of at once raising, almost to perfection, an art destined ever after to exercise so vast and so beneficial an influence on the affairs of the world. The *Psalter*, printed at Mentz by Faust and Schoiffer, in 1457, is the first Book which bears the Printer's name, with the date, and place of printing.

In general, in the very early printed Books, the name of the Printer, the date, and the place of printing, are either wholly omitted, or placed at the end of the Book, with some quaint ejaculation or doxology. The pages have no running title, or number, or catch-word, or signature-letters, to mark the order of the sheets. The character is uniformly Gothic, till 1467, when the Roman type was first introduced. There were no capitals to begin sentences; the only points used were the colon and full stop; and in almost every sentence there were abbreviations or contractions. In regard to these and other peculiarities of early printed Books, the reader may consult the following works: *The General History of Printing*, by Palmer (supposed, however, to have been chiefly written by the celebrated George Psalmanazer); Jungendres, *De notis characteristicis librorum a Typographiæ incunabilis ad an. 1500 impressorum*; and *Recherches sur l'origine des Signatures, et des Chiffres de page*, par Marolles.

Many of the early Printers had peculiar marks or vignettes, which they sometimes placed on the title-page, and sometimes at the end of the Books printed by them; and most of them, also, made use of monograms or cyphers, compounded of the initial or other letters of their names. These furnish a clue to the discovery of the Printer, where they occur on books without any Printer's name. An acquaintance with them, therefore, is necessary to the Bibliographer, because questions occur as to early

* See Vol. I. of Dr Clarke's *Bibliographical Dictionary*, for some curious details on this point.

Bibliography. editions which can only be decided by ascertaining the Printer's name. For explanations of these marks, the following works may be consulted:—Orlandi's *Origine e progressi della Stampa*, published at Bologna in one volume 4to, in 1722; and Scholtzius's *Thesaurus Symbolorum ac Emblematum*, in one volume folio, published at Nuremberg, in 1730. The monograms of the early English printers are explained in Ames's *Typographical Antiquities*.

The following works are appropriated to the description of early printed Books: 1. *Index Librorum ab inventa Typographia ad annum 1500, cum notis*; 2 vols. 8vo, 1791. This work, by Laire, is one of the best of its kind. The descriptions are clear, the notes brief and instructive; and there are four indexes, which furnish the means of ready reference to all the names, titles, places, and Bibliographical notices contained in the work: 2. *Dictionnaire Bibliographique choisi du quinzieme siècle*. Par Serna Santander, 3 vols. 8vo, 1805. This is a very learned and exact work; and, like the preceding, embraces only the rarest and most interesting publications of the fifteenth century. 3. *Bibliotheca Spenceriana*, or a descriptive Catalogue of the books published in the fifteenth century, in the Library of Earl Spencer; by the Rev. T. F. Dibdin; 4 vols. 8vo, 1814. The abundance and beauty of the fac-similes and other embellishments, as well as the fineness of the paper and printing, render this by much the most splendid Bibliographical work ever published in any country. It contains some curious information, enveloped, however, in a much greater proportion of tasteless and irrelevant matter. 4. *Annales Typographici ab Artis inventæ origine*, by Michael Maittaire, published in 4to, as follows: In 1719, volume first, which embraces the period from the origin of printing to 1500: volume second, published in 1722, extends the annals to 1536; and volume third, published in 1726, brings them down, according to the title-page, to 1557; but there is an Appendix, which affords a partial continuation to 1664. In 1733, the first volume was republished, with corrections and large additions, and is commonly called the fourth volume. The fifth and last volume, containing Indexes, was published in 1741. As four of the volumes consist each of two parts, the work is sometimes bound in five, sometimes in nine volumes. Several Supplements have been published to this elaborate work; the most valuable of them, that by Denis, in two volumes 4to, was published at Vienna in 1789; and contains 6311 articles omitted by Maittaire. The latter has enriched his Annals with many learned Dissertations; and the work is allowed to be the most important that has yet been compiled in England, in any department of Bibliography. But though written in this country, the last was the only volume published in it, the others having been published in Holland. 5. *Annales Typographici ab artis inventæ origine, ad annum 1500, post MAITTAIRE, DENISII, aliorumque emendati et Aucti; opera S. W. PAUZER*; 11 volumes 4to, published at Nuremberg, the first in 1793, the last in 1803. This work labours under great defects, in point of arrangement; but it is unquestionably the most complete of its kind that has yet appeared. It comes down to the year 1536, though the title-page of the first volume limits it to the fifteenth century.

VOL. II. PART II.

Bibliography. The works we have just described may fairly be set down as indispensable to every Bibliographical Collection. But they have a value, we think, independent of the assistance which they afford the Bibliographer, in his examination of the early productions of the Press; they are also calculated to interest the Philosopher as curious registers of the extent and objects of intellectual industry, during a period when the human mind began to be acted upon by new impulses, and to receive the seeds of revolutions destined to change the whole aspect of the intellectual world.

III. Of Rare Books.

Rareness is a circumstance which must, generally speaking, confer some degree of value upon Books; and it is, therefore, one of the objects of Bibliography to indicate those Books which, in a greater or less degree, come under this category. A passion for collecting Books, merely because they are rare, without inquiry as to any literary purpose they may be calculated to serve, is, no doubt, a very foolish habit; but it is just as foolish, on the other hand, to ridicule all solicitude about Books of this description; for this implies that every valuable Book is common; a notion which no one can entertain who has ever had occasion to follow out any particular line of literary research, to decide upon any fact involved in doubt or in controversy, or to speculate upon the progress of knowledge either in the Sciences or the Arts. With regard to the Bibliographical compilations appropriated to the description of Books of this class, it may be observed of most, if not all of them, that they have applied the epithet *rare* much too vaguely and lavishly. It must, indeed, in a multitude of cases, be exceedingly difficult to speak with precision on this point; so difficult as to render it impossible, we apprehend, to compile a work of this kind, which shall not frequently mislead those who consult it.

David Clement, the author of a very learned work of this class, which we shall immediately notice, assigns the following, as the different degrees in which Books may be said to be rare. A Book, which it is difficult to find in the country where it is sought, ought to be called, simply, *rare*. A Book, which it is difficult to find in any country, may be called *very rare*. A Book, of which there are only fifty or sixty copies existing, or which appears as seldom as if there never had been more at any time than that number of copies, ranks as *extremely rare*; and when the whole number of copies does not exceed ten, this constitutes *excessive rarity*, or rarity in the highest degree. This classification of the degrees of rareness is copied from Clement, by all subsequent Bibliographical writers in this department. It is abundantly obvious, that the justness of the application of these classifications to particular Books, must entirely depend on the extent and precision of the knowledge with which they are used.

We cannot in this department, any more than in the others embraced in this article, indicate any but the most prominent and useful Books belonging to it. The following, in this view, are particularly worthy of attention: 1. Beyer's, *Memoria*

o o

Bibliography.

Historico-critica Librorum rariorum, 1734, 8vo. 2. Vogt, *Catalogus historico-criticus Librorum rariorum*, 1732, 8vo. The last and best edition was published in 1793. In this work, the epithet *rare* is applied with more judgment and knowledge than in most others of the same class. 3. Gerdesii, *Florilegium historico-criticum Librorum rariorum*; first published in 1740, and again in 1763, in 8vo. It was partly intended as a Supplement to the preceding work by Vogt, and, therefore, notices only those books which are not included in his Catalogue. 4. *Bibliothèque curieuse, ou Catalogue raisonné des Livres rares*; par D. Clement. 1750-60. This work, to which we have before alluded, is compiled upon a more extensive plan than any of the preceding; for, though consisting of nine volumes quarto, it comes down no farther than to the letter H in the alphabetical arrangement of names; terminating here in consequence of the death of the Author. Clement is generally blamed, and with justice, for a very profuse and inaccurate application of his own nomenclature of rarity; his notes, too, are crammed with citations, and tediously minute; but, on the other hand, it must be allowed, that they contain many curious pieces of Literary History; and it has, upon the whole, been matter of regret to Bibliographers, that the work, voluminous as it must have proved, was not completed. 5. *Bibliotheca Librorum rariorum universalis*. Auctore Jo. Jac. Bawer; 7 vols. 8vo, 1770-91. This, we believe, is the latest publication of its class. It contains only the titles of Books without any further notices; and this being the case, it must be evident, that seven volumes could scarcely be occupied with titles of Books justly called rare.

IV. Of the Classics.

It is remarked by Mr Roscoe, "that the coincidence of the discovery of the art of Printing, with the spirit of the times in which it had birth, was highly fortunate. Had it been made known at a much earlier period, it would have been disregarded or forgotten, from the mere want of materials on which to exercise it; and, had it been farther postponed, it is probable, that many works would have been totally lost, which are now justly regarded as the noblest monuments of the human intellect." (*Lorenzo di Medici*, chap. i.) The rapid diffusion of the art, and the speedy appearance of the *Classics* in an imperishable form, afford sufficient proofs of the bent of the age, and the opportuneness of this great discovery. Gabriel Naudé observes, that almost all the good as well as bad Books then in Europe, had passed through the Press before the year 1474; * that is, within twenty years of the earliest date to which the use of moveable types can be carried. Within this period, editions had been printed of nearly all the Latin Classics. The whole works of some of them, of Cicero, for example, had not yet appeared in one uniform edition; but several of his treatises, the whole of Pliny the Elder, of Livy, Sal-

lust, Cæsar, Tacitus, Suetonius, Justin, Lucan, Virgil, and of Horace, had been published before the end of 1470. Most of these early editions of the Classics were published in Italy. England remained greatly behind her Continental neighbours in the naturalization of these precious remains of ancient learning. Of all the Classics, only Terence, and Cicero's *Offices*, had, in 1540, been published in this country in their original tongue. Caxton and others made use only of French translations in the early versions and abridgments published in England. Gawin Douglas, Bishop of Dunkeld, so well known for his Scottish poetical version of Virgil, has, in his preface to that work, commemorated his indignation at the injustice done to "the divine Poet" by Caxton's second-hand translation, in the following curious and emphatic lines:

Thoch Wylliam Caxton had no compatioun
Of Virgill in that buk he preynt in prois,
Clepend it Virgill in Eneados,
Quhilk that he sayis of Frenche he did translait,
It has nathing ado therwith, God wate,
Nor na mare like than the Deuil and sanct Austin.
Hauie he na thank tharfore, bot lois his pyne;
So schamefully the storie did peruerite,
I reid his work with harmes at my bert,
That sic ane buk, but sentence or ingyne,
Suld be intitult eflir the poete diuine.
His ornate goldin versis mare than gylt;
I spitte for dissipite to se thame spyt
With sic ane wicht, quhilk treuly be myne entent
Knew nevir thre wordis at all quhat Virgill ment.

Almost all the Latin Classics had appeared in print, before the art was employed upon any one Greek author. But the desire to possess printed editions of the latter became general and urgent towards the end of the fifteenth century; and Aldus had the glory of ministering to that desire, by publishing in rapid succession, and with singular beauty and correctness, almost all the principal authors in that tongue. Beginning in 1494 with Musæus's *Hero and Leander*, he printed before 1515, the year of his death, upwards of sixty considerable works in Grecian literature, frequently joining the learning and the cares of the Editor to those of the Printer. "Yet his glory," to use the words of Mr Gibbon, "must not tempt us to forget, that the first Greek Book, the *Grammar* of Constantine Lascaris, was printed at Milan in 1476; and that the Florence Homer of 1488 displays all the luxury of the Typographical art." (*History*, Chap. 66.) Besides these works, there had been published before 1494, some Greek *Psalters*, the *Batrachomyomachia* of Homer, and the *Orations* of Isocrates; during that year, the *Anthologia Græca* was published at Florence; and the works of Callimachus, of Apollonius Rhodius, and of Lucian, were published at the same place within two years after the first essays of Aldus in Greek printing. Thus, though we have no sort of wish to detract from the just fame of this learned and beautiful Printer, we cannot admit the propriety of those eulogies of his late Biographer M. Renouard, in which he is represented as having given

Bibliography.

* *Addition à l'Histoire de Louis XI.* Par G. Naudé.

Bibliography.

an entirely new direction to the art of Printing, and, indeed, to the literary taste of Europe.* It is as incorrect in point of fact, as it is unphilosophical, to ascribe to Aldus the production of that taste for Grecian literature which he himself imbibed from the spirit of his age. He saw that there was a great and growing want of Greek Books; and his peculiar praise lies in this, that he applied himself to supply this want, with much more constancy and skill, and with much more learning, than any other Printer of that period. All that we have said on this point, is fully corroborated by the account which he himself has given, in his Preface to Aristotle's *Organon*, published in 1495, of the circumstances which induced him to undertake the publication of the Greek Classics. The passage is translated by Mr Roscoe in his *Life of Leo the Tenth* (Vol. I. p. 110), and is as follows:—"The necessity of Greek literature is now universally acknowledged; insomuch, that not only our youth endeavour to acquire it, but it is studied even by those advanced in years. We read but of one Cato among the Romans who studied Greek in his old age, but in our times we have many Catos; and the number of our youth, who apply themselves to the study of Greek, is almost as great as of those who study the Latin tongue; so that Greek Books, of which there are but few in existence, are now eagerly sought after. But by the assistance of Jesus Christ, I hope ere long to supply this deficiency, although it can only be accomplished by great labour, inconvenience, and loss of time. Those who cultivate letters must be supplied with Books necessary for their purpose, and till this supply be obtained, I shall not be at rest."

The *Éditiones Principes* of the Classics have always formed capital objects in Bibliography, and are sometimes spoken of with a degree of rapture in Bibliographical works, which is apt to appear inappropriate and unreasonable to those who covet books solely as they are calculated to afford delight or information. The lover of first editions has, however, some plausible reasons to assign in justification of this expensive, and, as some think, factitious passion. These editions, it is said, are valuable, in the first place, as curious monuments of early Typography, and, in the next place, as being more faithful representatives of the best ancient Manuscripts, than any other editions. *Earum editionum auctoritatem*, says Maittaire, *aliis omnibus esse preferendum, quippe quæ solâ MSS. fida nitatur*. This ground of preference, however, has some learn-

ed opponents. Schelhorn, in his *Amanitates Literariæ*, speaks of those to whom we are indebted for the first editions of the Classics, as, in general, very ignorant men; quite incapable to collate Manuscripts themselves, and seldom taking assistance from those who were. The first Manuscript that could be procured, it has been said by others, and not that which, after a careful collation, appeared entitled to a preference, was hastily committed to the Press, in order to take advantage of the recent discovery. Thus Grævius, in the Preface to his edition of Cicero *De Officiis*, states, that the celebrated *editio princeps* of that work, by Faust, was printed from a very inaccurate manuscript. † On the other hand, there are many who view those editions in the same light with Maittaire. M. La Grange assures us, in the Preface to his French translation of Seneca's works, that he never, in any case of difficulty, consulted the *editio princeps* of 1475, without finding there a solution of his doubts; adding generally, *que ceux qui studient les auteurs anciens, soit pour en donner des Éditions correctes, soit pour les traduire dans une autre langue, doivent avoir sans cesse sous les yeux les premiers Éditions de ces auteurs*. To the same purpose, M. Serna Santander observes, that the *Éditio Princeps* of Pliny the Elder, printed at Venice by Spira in 1469, is in many places more accurate than the celebrated edition of Father Hardouin. The truth seems to be, that though many first editions have a real literary value for such purposes as are specified by M. La Grange, there are others which have no value save what their extreme rareness gives them;—that, therefore, they who scoff at, and they who laud indiscriminately these literary rarities, are equally in the wrong;—in a word, that we must apply a different rule of estimation to the first editions of such a Printer as Aldus, and those of Sweynhelm and Pannartz. ‡

The Classics have often been published in Sets more or less complete, and more or less estimable for beauty, correctness, commentaries, and so forth. Lists of all these sets, with remarks on their relative extent and merits, will be found in the Bibliographical works to be immediately mentioned. As the origin of the *Delphin* Collection forms an interesting piece of Literary History, it may not be improper to notice it more particularly. This celebrated body of Latin Classics was originally destined for the use of the Dauphin, son of Louis XIV.; and was projected by his Governor the Duke of Montausier. This nobleman, who, though a Courtier and Soldier, was both a Philosopher and a Scholar, had been in the habit of carrying some of the Classics along with him in all his cam-

Bibliography.

* *Annales de l'Imprimerie des ALDE, ou Histoire des trois MANUCE, et de leurs Editions*. Par A. G. Renouard. 2 tomes 8vo. Paris, 1803.

† See a curious chapter on *First Editions* in Marchand's *Histoire de l'Imprimerie*. He mentions, as a piece of extreme folly, that one hundred guineas had been paid for a copy of the first edition of Boccaccio; but if that price deserved such a censure, what epithet shall we bestow on a late purchase of a copy, for which L.2260 was paid?

‡ When Mr Dibdin tells us, *Introduction to the Classics*, v. AULUS GELLIUS, "that all the first editions printed by Sweynhelm and Pannartz are considered as particularly valuable by the curious in Bibliography," he should have added, chiefly on account of their being *curiosities* from their great rarity, and not on account of their superior accuracy.

Bibliography.

paings; and had often experienced impediments to their satisfactory perusal, from the recurrence of difficulties and allusions, which could not be removed or explained, without Books of reference, too bulky for transport on such occasions. It was in these circumstances that the idea first occurred to him of the great utility of a uniform edition of the principal Classics, in which the text of each should be accompanied with explanatory notes and illustrative comments; and when he became Governor to the Dauphin, he thought that a fit opportunity to set on foot an undertaking calculated to prove so useful to the studies of the young Prince. Huet, Bishop of Avranches, then one of the Dauphin's Preceptors, was accordingly commissioned to employ a sufficient number of learned men for this purpose, and to direct and animate the whole undertaking. Once every fortnight they came to him on a stated day, each with the portion of his work which he had finished in the interval, to undergo his inspection and judgment. The copious verbal indexes, which constitute so valuable a portion of these editions, were added at his suggestion; but not without considerable opposition on the part of his assistants, who were appalled by the prospect of so much irksome labour as would be necessary to do justice to this part of the plan. (*Memoirs of Huet's Life, Book 5.*) The collection, including Danet's *Dictionary of Antiquities*, extends to sixty-four volumes quarto. "It is remarkable," says Dr Aikin, in one of the notes to his excellent translation of *Huet's Memoirs*, "that Lucan is not among the number. He was too much the Poet of liberty to suit the age of Louis XIV."

The following are the most useful Bibliographical accounts of the Classics: 1. *A View of the Various Editions of the Greek and Roman Classics, with Remarks*, by Dr Harwood. This work, first published in 1776, has gone through several editions; the larger works of the same kind, to which it gave rise, not having superseded it as a convenient manual in this department of Bibliography. 2. *Degli Autori Classici sacri profani, Græci e Latini, Bibliotheca portatile*; 2 vols. 12mo, Venice, 1793. This work was compiled by the Abbé Boni, and Bartholomew Gamba; and contains a translation of the preceding, with corrections and large additions, besides criticisms on the works of Bibliographers, and a view of the origin and history of Printing. 3. *An Introduction to the Knowledge of Rare and Valuable Editions of the Classics*, by T. F. Dibdin. The first edition was published in 12mo, in 1803; but it has since been greatly enlarged in two octavo editions, the last of which appeared in 1808. The utility of this work is considerably enhanced by the full account which it contains of Polyglott Bibles, of the Greek and Latin editions of the Septuagint and New Testament, and of Lexicons and Grammars.

The improved editions, by Harles and Ernesti, of the *Bibliotheca Græca* and *Bibliotheca Latina*, of Fabricius, are well known to the learned, as immense

magazines of information in regard to the Classics Bibliography and classical literature; but as they extend over a much wider field of inquiry than is embraced by Bibliography, it does not belong to our present subject to give a more particular account of them.

V. Of Anonymous and Pseudonymous Books.

The great number of Books published anonymously, as well as under false or feigned names, early directed the attention of the learned to this branch of Bibliographical inquiry. In 1669, Frederic Geisler, a Professor of Public Law at Leipsic, published a Dissertation *De Nominum Mutatione*, which he reprinted in 1671, with a short catalogue of anonymous and pseudonymous authors. About the same period, a similar but more extensive work had been undertaken by Vincent Placcius, Professor of Morals and Eloquence at Hamburg, and which was published in 4to in 1674, with this title: *De Scriptis et Scriptoribus, anonymis atque pseudonymis, Syntagma*. Four years thereafter, John Decker, a learned German Lawyer, published *Conjectura de scriptis adespotis, pseudepigraphis, et supposititiis*; which was republished in 1686, with the addition of two Letters upon the same subjects; one by Paul Vindingius, a Professor at Copenhagen, and the other by the celebrated Peter Bayle. In 1689, John Mayer, a Clergyman of Hamburg, published a letter to Placcius, under this title: *Dissertatio epistolica ad Placcium, qua anonymorum et pseudonymorum farrago exhibitur*. Placcius, meanwhile, had continued his inquiries; and after his death, the fruits both of his first researches and additional discoveries were embodied in one work, and published in a folio volume, at Hamburg, in 1708, by Mathew Dreyer, a Lawyer of that city. The work was now entitled, *Theatrum Anonymorum et Pseudonymorum*; and, besides an Introduction by Dreyer, and a Life of Placcius, by John Albert Fabricius, it contains, in an appendix, the before-noticed treatises of Geisler and Decker, with the relative Letters of Vindingius and Bayle, as well as Mayer's *Dissertatio Epistolica*, addressed to Placcius. This very elaborate work contains notices of six thousand books or authors; but it is ill arranged, often inaccurate, and three-fourths of it are made up of citations and extracts, equally useless and fatiguing.*

A part of this subject, that relating to Books published under false or fanciful names, had been undertaken in France by Adrian Baillet, nearly about the same period that Placcius commenced his inquiries. In 1690, this author published his *Auteurs Déguisés*; but this is little more than the Introduction to an intended Catalogue of such authors, which Baillet never completed; being deterred, as Nicéron says, by the apprehension, that the exposing of concealed authors might some way or other involve him in trouble. In this piece, which was reprinted in the sixth volume of De la Monnoye's edition of Baillet's *Jugemens des Savans*, there are some curious

* See the copious article on Placcius, in *Chauspié's Nouveau Dictionnaire Historique et Critique*. Tom. III.

Bibliography.

literary anecdotes; particularly those illustrative of the rage which obtained after the revival of letters, for the assumption of classical names. In Italy, these names were so generally introduced into families, that the names of the Saints, hitherto the common appellatives, almost disappeared from that country.

The taste for this species of research, which the work of Placcius had diffused in Germany, produced several Supplements to it in that country. In one published at Jena, in 1711, under the name of Christopher Augustus Neuman, there is, besides the list of authors, a dissertation upon the question, Whether it is lawful for an author either to withhold or to disguise his name? which question he decides in the affirmative. This work is entitled, *De Libris anonymis et pseudonymis Schediasma, complectens observationes generales, et Spicilegium ad PLACCII Theatrum*. But the most considerable of these Supplements was that published by John Christopher Mylius, at Hamburg, in 1740. It contains a reprint of the *Schediasma* of Neuman, with remarks; and a list of three thousand two hundred authors, in addition to those noticed by Placcius. The notices of Mylius, however, are limited to books in the Latin, German, and French languages.

About the middle of last century, the Abbé Bonardi, Librarian to the Sorbonne, undertook a Dictionary of anonymous and pseudonymous works, but he died without publishing it. The manuscript is said to have been carried to Lyons; and, it is supposed, was destroyed there, during the disorders that followed the Revolution. In the third volume of Cailleau's *Dictionnaire Bibliographique*, published in 1790, there is a separate alphabet for anonymous Books, which occupies about half the volume. It embraces Books in all languages, but those only which the compiler thought rare or curious. The last, and by far the best work in this department, is the *Dictionnaire des ouvrages Anonymes et Pseudonymes*, by M. Barbier, Librarian to the late Emperor of France. It consists of four volumes octavo; two of which were published in 1806, and the remaining two in 1809. It comprises above twelve thousand articles; but the plan does not embrace any English, German, or Italian works, but those which have been translated into the French language. Works of this class are more particularly useful in regard to the literary productions of periods and countries which have been greatly restricted in the liberty of the Press. M. Barbier states, that in every Library composed of useful Books, it will be found, that a third part have not the names of the authors, translators, or editors; a proportion which, if true at all, can only hold true, we think, of Continental Libraries.

VI. Of Condemned and Prohibited Books.

Books supposed hurtful to the interests of government, religion, or morality, have sometimes been condemned to the flames, sometimes censured by particular tribunals, and sometimes suppressed. These

measures have been followed by particular countries, both in respect to their own productions and those of their neighbours. In some countries, lists of the Books prohibited within them, have, from time to time, been published; and in these lists are often found the most highly prized productions of the Literature of other nations. This constitutes, indeed, a melancholy portion of the history of Books; for though the facts which it collects sometimes amuse by their folly, they oftener excite indignation and pity at the oppressions of Power, and the sufferings of Learning.

The practice of condemning obnoxious Books to the flames is of very ancient date. The works of Protagorus of Abdera, a disciple of Democritus, were prohibited at Athens, and all the copies that could be collected were ordered to be burnt by the public crier. Livy mentions, that the writings of Numa, which were found in his grave, were condemned to the flames, as being contrary to the religion which he had himself established. Augustus caused two thousand Books, of an astrological cast, to be burnt at one time; and he subjected to the same doom, some satirical pieces of Labienus. Tacitus mentions a work which the Senate, under Tiberius, condemned to the fire for having designated Cassius as the last of the Romans.* This practice was early introduced in the Christian world. "After the spreading of the Christian religion," says Professor Beckmann, "the Clergy exercised against Books that were either unfavourable or disagreeable to them, the same severity which they had censured in the heathens, as foolish and prejudicial to their own cause. Thus were the writings of Arius condemned to the flames at the Council of Nice; and Constantine threatened with the punishment of death those who should conceal them. The Clergy assembled at the Council of Ephesus, requested Theodosius II. to cause the works of Nestorius to be burnt, and this desire was complied with. The writings of Eutyches shared the like fate at the Council of Chalcedon; and it would not be difficult to collect examples of the same kind from each of the following centuries."

When the Popes caused the nations of Christendom to acknowledge their infallibility in all matters appertaining to religion, they also took upon themselves the care and the right of pointing out what Books should, or should not, be read; and hence originated those famous *Expurgatory Indexes*, which furnish such ample materials for the Bibliography of prohibited Books. There is a copious list of these *Indexes* in the work of Peignot, to be immediately noticed. The next step in the progress of usurpation was the *licensing* of Books. By the Council of Lateran, held at Rome in 1515, it was ordered, that in future all Books should, previous to publication, be submitted to the judgment of Clerical Censors. "To fill up the measure of encroachment," says Milton, "their last invention was to ordain, that no Book should be printed, as if St Peter had bequeathed them the keys of the Press also, as well as of Paradise, unless it were approved and licensed under the hands of two or three gluttonous Friars. Till

Bibliography.

* See the chapter on *Book Censors* in Professor Beckmann's *History of Inventions*.

Bibliography. then, Books were ever as freely admitted into the world as any other birth; the issue of the brain was no more stifled than the issue of the womb; no envious Juno sat cross-legged over the nativity of any man's intellectual offspring." (*Speech on the Liberty of unlicensed Printing.*)

The following works contain accounts of condemned and prohibited Books, and of the *Indices Expurgatorii*. 1. *Dissertatio historico-literaria de libris combustis*, in the seventh volume of Schellhorn's *Amœnitates Literariæ*. The same subject is resumed in the eighth and ninth volumes. 2. *Index generalis librorum prohibitorum a Pontificis; in usum Bibliothecæ Bodleianæ*; by Tho. James, 1627. We do not know that any other work of this kind was ever published in England. 3. FRANCUS *De Papistarum Indicibus librorum prohibitorum*, published at Leipsic in 1684. 4. *Thesaurus Bibliographicus ex Indicibus librorum prohibitorum congestus*, published at Dresden in 1743. 5. *Dictionnaire Critique et Bibliographique des principaux Livres condamnés au feu, supprimés ou censures*, par G. Peignot, 2 vols. 8vo, Paris, 1806. This Book is amusing, and gives a copious list of *Indices Expurgatorii*, as well as of authors who have treated of the subject of condemned Books in general: but it cannot be allowed, that it contains anything approaching to a complete enumeration of the principal works which come under the scope of the title-page. There are very few English Books noticed, either those condemned in this country, or those prohibited in others; though in this latter class, the most valuable of our philosophical and literary works would be found to be named. One of the most preposterous sentences of prohibition, incurred by an English author, is that mentioned in a letter from Sir John Macpherson, while in Spain, to Mr Gibbon, viz. that Smith's *Wealth of Nations* was prohibited there "on account of the lowness of its style, and the looseness of its morals." (*Gibbon's Posthumous Works*, Vol. III.)

We should like to see an accurate account of works which have been condemned to the flames, or suppressed, in Britain. In former times, we should find some as abominable instances of oppression in this particular, as ever disgraced the worst governments of Continental Europe. The proceedings against William Prynne, on account of his *Histriomastix*, or *Player's Scourge*, furnish a noted example. We wish we could add, that these proceedings have always been mentioned in our Histories, in the terms which their singular atrocity is calculated to call forth from every heart that has one chord in unison with the rights of humanity. Prynne, who was by profession a Lawyer, is characterized by Mr Hume as being "a great hero among the Puritans." He was in truth a very fanatical person; but his learning was immense, his courage unconquerable, and his honesty certainly as great as that of any of his op-

Bibliography.ponents or oppressors. His *Histriomastix*, a quarto of upwards of a thousand closely printed pages, with all its margins studded with authorities, came out in 1633; and was intended to decry all dramatic amusements, and all jovial recreations, and to censure the lax discipline, and the Popish ceremonies of Prelacy. In the Alphabetical Table at the end of the volume, there is a reference in these words, — *Women actors, notorious whores*; and as the Queen sometimes acted a part in Dramas played at Court, it was represented that Prynne pointed at her Majesty in this reference, and that the Book was in fact intended as a satire upon the Government. He was accordingly prosecuted in the Star-Chamber for a libel. The Book, which the Judges described as a huge misshapen monster, in the begetting of which the Devil must have assisted, was condemned to be burned; and after the example of foreign countries, this was ordered to be done, for the first time in England, by the hands of the hangman. It was ordered, that Mr Prynne should be expelled from Oxford, he being a graduate in that University; and also from the Bar. He was farther sentenced to pay a fine of five thousand pounds, and to endure perpetual imprisonment; but this was not yet all; he was condemned to stand in the Pillory on two successive days, in Westminster and Cheapside, there, on each day, to have an ear cut off. One of the Judges, who represented the Queen's virtues as such that neither oratory nor poetry could do any thing like justice to them, was for making the fine ten thousand pounds; stating, that he knew it was much more than Mr Prynne was worth, yet far less than he deserved to pay; and he wished farther, that his nose should be slit and his forehead burned in addition to the loss of his ears, because he might buy himself a perriwig, and so hide that loss.* The Book, which involved its author in such unprecedented calamities, had actually been licensed, according to the regulations which then obtained for the licensing of Books for publication; but it was stated, that the Licenser had not read the whole of it. Well might Sir Simonds D'Ewes speak of this as a terrifying trial. "Most men," says he, "were affrighted to see, that neither Mr Prynne's Academical nor Barrister's Gown could free him from the infamous loss of his Ears; and all good men conceived this would have been remitted; many asserted it was, till the sad execution of it. I went to see him a while after," continues Sir Simonds, "in the Fleet, to comfort him; and found in him the rare effects of an upright heart, by his serenity of spirit and cheerful patience."† The account which Mr Hume gives of this nefarious trial and sentence—dwelling chiefly on the acrimonious and ridiculous parts of the Puritan Prynne's character and Book—wholly passing over the miscreant sycophancy of his Judges, and but gently censuring their appalling and ruthless cruelty—is characteristic enough of

* See Prynne's Trial in the Collection of *State Trials*, Vol. III. of the 8vo Edition.

† See Extracts from *M.S. Journal of D'Ewes's Life*, published in Nichols's *Bibliotheca Topographica Britannica*, No. XV.—These Extracts contain some curious scraps of history and anecdote; but it is much to be regretted that the Editor had not the discretion to suppress the atrocious calumny upon Lord Bacon.

Bibliography. his general principles and manner; and well calculated to show, that, with all his penetration, and philosophic spirit, and charms of style, he was still deficient in some qualities of a Historian, without which, History cannot be rendered profitable either to Princes or to People.

VII. Of Bibliographical Dictionaries and Catalogues.

The works which fall to be considered under this section, sometimes called *Dictionaries*, sometimes *Catalogues*, and sometimes *Bibliothecæ*, constitute the most generally useful and interesting class of Bibliographical publications. By showing what has been written in all the various branches of human knowledge, in every age and country, they act as useful guides to the inquiries of every class of the learned; while, by pointing out the differences of editions, they constitute manuals of ready information to the professed Bibliographer.

Works of this class are called *General* or *Particular*, according as their object is to indicate Books in all, or in one only, of the departments of Science and Literature. The former only aspire to point out rare or remarkable Books; for no attempt has yet been made, or probably ever will be made, to compile a *universal* Bibliographical Dictionary. On the other hand, it is the object of *particular* Dictionaries to notice all, or the greatest part, of those Books which have been published on the subjects which they embrace; and hence their superior utility to those who are engaged in the study of any particular science or subject.

The works of the former class, which chiefly demand our notice, are the following:—1. *Bibliographie Instructive, ou Traité de la Connoissance des Livres rares et singuliers*, par G. F. De Bure; in seven volumes octavo, published at Paris between 1768 and 1768. The books described in this work are arranged, in appropriate subdivisions, under the five grand classes of *Theology, Jurisprudence, Sciences and Arts, Belles Lettres, and History*; and the classification which it exemplifies is that generally followed by foreign Bibliographers. The names of the authors in all these classes are arranged alphabetically in the last volume; but it has no index to anonymous works,—a want, however, which was afterwards supplied by another hand, in a thin octavo volume published in 1782, entitled *Bibliographie Instructive, tome dixieme*. This is called the tenth volume, because De Bure had himself published a Supplement of two volumes in 1769. Its title is, *Supplément à la Bibliographie Instructive, ou Catalogue des Livres de Louis Jean Gaignat*. De Bure was a Bookseller at Paris, of great eminence in his profession, but still more distinguished for extensive information in all matters appertaining to Bibliography and Literary History; and, accordingly, his work is still the delight of Bibliographers, though it has been followed by others which indicate a much greater number of Books, and which also, in some particulars, excel it in accuracy. 2. *Dictionnaire Typographique, Historique, et Critique, des Livres rares, estimés et recherchés en tous genres*, par J. B. L. Osmont;

2 vols. 8vo, Paris, 1768. This work is more ample in notices of Italian Books than that of De Bure. 3. *Dictionnaire Bibliographique*, 3 vols. 8vo. Paris, 1790. This work, generally known under the name of Cailleau's *Dictionary*, was compiled, according to M. Barbier and others, by the Abbé Du Clos. It was republished in 1800, with a Supplementary volume, by M. Brunet. It has been already mentioned, that the third volume has a separate alphabet for anonymous Books. 4. *Manuel du Libraire et de l'Amateur de Livres; contenant, 1o, Un nouveau Dictionnaire Bibliographique; 2o, Une Table en forme de Catalogue Raisonné*; par J. C. Brunet. This work was published in three volumes octavo in 1810, and republished with large additions, making in all four volumes, in 1814. It contains a much greater proportion both of English and of German Books, than any of the preceding compilations; and its plan is such as to afford all the advantages both of a Dictionary and a Classed Catalogue; three of the volumes being employed to indicate Books under their names in alphabetical order; and the fourth, to class them, divested of all Bibliographical details, according to the system generally followed. The prices of the rarer Books are given from the principal sales that have taken place of late years in France and other countries; so that, upon the whole, this work, though it has less literary interest than that of De Bure, is probably the best Bibliographical Dictionary extant, for the purposes of the professed Bibliographer.

In the class of *General* Bibliographical Dictionaries we must also place the following work, though its limitation to Books in the learned and Eastern languages, renders it much less general in its plan than those we have described. It is entitled, *A Bibliographical Dictionary, containing a Chronological Account, alphabetically arranged, of the most curious and useful Books in all departments of Learning, published in Latin, Greek, Hebrew, Arabic, and other Eastern languages*. It was published in 1808, in six volumes duodecimo, and the author, we believe, is Dr Adam Clarke. To the principal works noticed in this Dictionary, there are added Biographical Notices and Criticisms; but the author would have judged more wisely, had he included Books in the modern languages, instead of deviating so largely, and with such small pretensions to novelty, into the provinces of Biography and general Criticism. The Supplement, which he published in two duodecimo volumes in 1806, under the title of *The Bibliographical Miscellany*, contains, among other matters, an account of English translations of the Classics and Theological writers; a list of the cities and towns where printing was established in the fifteenth century; and a list of authors on Literary History and Bibliography.

Some writers have complained, particularly M. Camus, that these Bibliographical Dictionaries have been too exclusively devoted to the indication of rare and curious Books; and that they notice but few comparatively, of those whose value consists only in their utility. "Je voudrois," says he, "qu'on suppléât à ce défaut; et que, dans une Bibliographie formée sur un non nouveau plan, on indiquât quels sont, re-

Bibliography.

Bibliography.

Bibliography. lativement a chaque genre de connoissance, les livres les plus instructifs."* The *Manuel* of M. Brunet, we may observe, which was published subsequent to the period of this remark, contains the titles of a much greater number of useful Books, than are to be found noticed in any of the other *General Bibliographical Dictionaries*; but it certainly does not, and indeed was not intended, to realize the idea of such a *Dictionary* as was wished for by M. Camus.

It has sometimes also been alleged, that these *Dictionaries*, by pointing out so many curious Books, and rare Editions, have contributed greatly to the diffusion of that singular species of disease called the *Bibliomania*. We do not doubt that they may have helped to do so; but the truth is, that this disease has a much deeper root in the vanities of human nature, and is of much more ancient date, than some persons seem to imagine. It gave great offence to Socrates and to Lucian;† and its prevalence among his countrymen had called forth the animadversions of Bruyere, long before the popular work of De Bure gave such an acknowledged zest and pungency to the taste for amassing literary curiosities.

The number of *Dictionaries*, *Catalogues*, and *Bibliotheca*, applicable to particular departments or provinces of Learning, is much too great to permit us to do anything more than to point out a few of the most remarkable and useful among them. Lipenius, a learned German Divine and Professor, born in 1630, and who died in 1692, worn out, as Nicéron says, by labour and chagrin, compiled a *Bibliotheca Theologica*, a *Bibliotheca Juridica*, a *Bibliotheca Philosophica*, and a *Bibliotheca Medica*, making in all six volumes folio. The *Bibliotheca Juridica* has been several times reprinted, and two Supplements have been added to it, one by Schott, published at Leipzig in 1775, and the other by Senkenberg, also published there in 1789, making in all four volumes folio. An immense number of Books are indicated in each of these *Bibliothecæ* of Lipenius; of all of which the plan is, to arrange the Books alphabetically according to their subjects, each *Bibliotheca* having also an alphabetical table of the names of the authors whose works are arranged under the alphabet of subjects. The *Bibliotheca Juridica*, owing to the corrections and additions which it has received, forms by much the most valuable part of this series. In regard to Jurisprudence, we may farther mention Bridgman's *Legal Bibliography*; and the valuable work of M. Camus, entitled, *Lettres sur la profession d'Avocat, et Bibliothèque choisi des Livres de Droit*. There are some truly excellent *Catalogues* of Works in the Sciences, and in Natural History. Such are Dr Young's *Catalogue of Works relating to Natural Philosophy and the Mechanical Arts*, annexed to his *Lectures on Natural Philosophy*; the *Bibliotheca Mathematica* of Murhard; the *Bibliographie Astronomique* of La Lande; and the *Catalogus Bibliothecæ Historia Naturalis* JOSEPHI BANKS, by Dr Dry-

Bibliography. ander; which, though the title seems to promise only the catalogue of a private Library, is allowed to furnish the most complete and best arranged view of Books in Natural History, ever published in any country. In the great department of History, there have been published various *Bibliothecæ*, some of them embracing the historical works of all ages and countries, and others, those only which relate to particular countries. The *Bibliotheca Historica* of Meusel, an immense work, consisting of above twenty volumes, and not yet completed, is of the former class. It includes *Voyages and Travels*; but of Books of this class, there is an excellent separate Catalogue in six volumes octavo, by M. Boucher de La-Richarderie; published at Paris in 1808. We must observe, however, that this work would have been better suited to the legitimate ends of such a compilation, had the author confined himself to *Bibliographical notices*, and wholly refrained from those long extracts by which his Book has been so much enlarged. Of the class of *Bibliothecæ* applicable to the history of particular countries, the *Bibliothèque Historique de la France*, originally published in 1719 in one volume folio, but in the last edition published between 1768 and 1778, extended to five volumes, is by far the most splendid and perfect example. It contains nearly fifty thousand articles as well in Manuscript as Printed, methodically arranged under the different heads of French history to which they relate, and accompanied with a complete set of indexes to authors and subjects.

We must refer such of our readers as are desirous of seeing a fuller list of *Catalogues* of Books in the different branches of knowledge, to the *Répertoire Bibliographique Universel* of M. Peignot; a useful, but ill arranged Book.

It does not belong to our plan to notice *Catalogues* of particular Libraries; but we may observe, that *Classed Catalogues* of extensive Collections are justly regarded as rich storehouses of information by all inquirers after Books. We cannot but add, that in this Country, we are greatly, we might with propriety say, shamefully, behind the Continental Nations in this respect. *Catalogues* of this kind might have been expected from the Directors of the British Museum, and from the great Universities of Oxford and Cambridge, so rich in Books, in leisure, and endowments; but it was a Law Society of Scotland, we believe, namely, the Society of *Writers to his Majesty's Signet*, which set the first example in Britain, of publishing a *Catalogue* of their Library, so arranged, as to enable every one to turn at once to the class of Books which immediately interests his inquiries.

VIII. Of the Classification of Books.

The classing of Books in a *Catalogue*, so as to furnish a correct systematic view of the contents of an extensive Library, is a task of great difficulty and im-

* *Memoires de l'Institut National*.—Class—Litt. et Beaux Arts. Tom. II.

† Lucian's piece, called in Francklin's translation of his works, *The Illiterate Book-Hunter*, is perhaps the bitterest satire upon Book-Collectors, who are not Book-readers, ever printed.

Bibliography.

importance. In order to this, it is necessary to refer every Book to its proper place in the general system of human knowledge; and to do so with precision, it is necessary to have clear and exact ideas of the scope and objects of all the departments and branches of which that system consists. The utility of Catalogues so classed is very great, and consists obviously in this, that the Books upon any subject are found at once by referring to the proper head; whereas in Alphabetical Catalogues, the whole must be perused before we can ascertain what Books they contain upon the subjects which interest us. All who duly consider the matter, therefore, must concur in Dr Middleton's brief and emphatic description of such an undertaking, as *res sanè magni momenti, multique sudoris*. *

Whether Classed Catalogues were in use among the ancients, is a piece of information which has not descended to us. The first who is known to have written upon the subject was a German, named Florian Treffer, who published a method of classing Books, at Augsburg, in 1560. Cardona, in 1587, and Scholt, in 1608, published treatises upon this subject; and in 1627, Gabriel Naudé, a writer of no small celebrity in his day, published his *Avis pour dresser une Bibliothèque*, in which he treats of the principles of classification. The Catalogue which he compiled of the Library of the Canon De Cordes, afterwards purchased by Mazarin, was published in 1643, and is esteemed a curiosity among Bibliographers. In the early part of the eighteenth century, Gabriel Martin, a learned Parisian Bookseller, who seems to have been much employed in compiling Catalogues, chalked out a system of arrangement, which, in a great degree, superseded all other systems, and which, in its leading divisions, is still generally followed on the Continent. Various other systems have, however, been proposed by the Bibliographers of France and Germany; but, before proceeding to any particular notice, either of the system of Martin, or of those which differ from it, we must observe, that all who have written upon the subject, seem to have confounded two objects, as we think, perfectly distinct—the arrangement to be followed in the Catalogue of a Library, and that to be followed in placing its Books. They all suppose the same nicety and exactness of classification to be equally necessary, and equally practicable in both. Now, we must remark, that where there is a Classed Catalogue, the grand objects of all arrangement are sufficiently provided for, independently of the location of the Books; and, if there should not be a Classed Catalogue, it seems very clear, that the bulk of those who frequent a public Library, could derive little, if any, benefit from an elaborate classification of the Books on the shelves;

even supposing it practicable to effect and maintain it. The chief end of any arrangement that is made on the shelves, ought to be, to aid the memory, and abridge the labour of the Librarians; and all that is useful in this respect, may be accomplished, by means of a much ruder plan, than could be tolerated in any Catalogue pretending to Classification.

The system generally followed, as we have already mentioned, is that of Martin; which divides books into the five great classes of *Theology, Jurisprudence, Sciences and Arts, Belles Lettres, and History*. Each of these classes has divisions and subdivisions more or less numerous, according to the number of the branches to be distinguished; and it is in the distribution of these, that the chief differences are found in foreign Catalogues; though the divisions and subdivisions of De Bure, as exemplified in his *Bibliographic Instructive*, are those commonly followed. Some Bibliographers, however, have proposed to alter the order, others to diminish, and some to increase the number of the primitive classes; while a few have proposed systems altogether different, and greatly more refined in their principles of classification. M. Ameilhon, in a paper published in the *Memoirs* of the French Institute, proposes the following leading divisions: Grammar, Logic, Morals, Jurisprudence, Metaphysics, Physics, Arts, Belles Lettres, and History. † In this arrangement, *Theology*, to which he has great objections as a separate class, is transferred, with evident impropriety, to the class of *Metaphysics*. M. Camus has also investigated the principles according to which Books ought to be classed, in another paper in these *Memoirs*, already quoted; but, as he has not reduced his method, which proceeds on views much too fanciful for the purpose, to specific heads, we can only refer our readers to his paper. Equally remote from the proper objects of a classed Catalogue, are the systems proposed by M. Peignot, and by M. Thiebaut. ‡ The former takes the well known speculations of Bacon and D'Alembert, as to the Genealogy of Knowledge, for the basis of his system; and thus fixes upon three principal heads or classes, under the names of History, Philosophy, and Imagination; with the addition of Bibliography as an introductory class. In the system of the latter, there are, in like manner, only three principal heads, founded upon a division of Knowledge, into knowledge Instrumental, Essential, and Suitable.

Germany has also produced a variety of Bibliographical systems; some of them as absurdly refined as those just mentioned; while others, that of Leibnitz, for example, are better adapted to practical purposes. The classes proposed by this eminent Philosopher are as follows: Theology, Jurisprudence, Medicine, Intellectual Philosophy, Mathematics, Natural

Bibliography.

* See his very judicious Tract, entitled, *Bibliotheca Cantabrigiensis Ordinanda Methodus*, in the fourth Volume of his Works.

† *Mémoires de l'Institut National*. Class—Litt. et Beaux Arts, T. II.

‡ See *Dictionnaire de Bibliologie*, par G. Peignot, art. Systeme.

VOL. II. PART II.

Bibliography. Philosophy, Philology, History, and Miscellanies.* Another system, not very remote from this, is that proposed by M. Denis, keeper of the Imperial Library at Vienna; in which books are divided into the classes of Theology, Jurisprudence, Philosophy, Medicine, Mathematics, History, and Philology. This system is developed in his *Introduction to the Knowledge of Books*, to be afterwards described.

Dr Middleton is the only British author, so far as we know, who has written any separate tract on the classification of Books. The classes proposed by him are these: Theology, History, Jurisprudence, Philosophy, Mathematics, Natural History, Medicine, Belles Lettres (*Literæ humaniores*), and Miscellanies. His object in the tract referred to, was to recommend the adoption of this arrangement for a Catalogue of the University Library of Cambridge; and whatever may be its defects, it cannot be questioned that a printed Catalogue of this collection so classed, would have proved of much utility; and would have helped to wipe away that stain of remissness in this particular, which still unfortunately attaches to our great Universities.

Naudé mentions a writer, who proposed to class all sorts of Books under the three heads of Morals, Sciences, and Devotion; and who assigned, as the grounds of this foolish arrangement, these words of the Psalmist, *Disciplinam, Bonitatem, et Scientiam doce me*. We confess, that all such systems as those of M. Peignot and M. Thiebaut, when applied to the formation of Catalogues, appear to us quite as absurd as this system deduced from the *Canticles*. The remark which Naudé applied to it, that it seemed intended "to crucify and torture the memory by its subtilities," is just as applicable to the former. That system, he adds (we use the words of Evelyn's *Translation of his Avis pour dresser une Bibliothèque*), "is the best, which is most facile, the least intricate, and the most practised; and which follows the faculties of Theology, Physic, Jurisprudence, Mathematics, Humanity, and others." M. Amcilhon also objects decidedly to all over refined Bibliographical systems, and particularly to those which aspire to follow the genesis and remote affinities of the different branches of knowledge. "L'exécution," says he, "en seroit impossible; ou si elle ne l'étoit pas, au moins entraineroit-elle des difficultés, qui ne pourroient être surmontées que par des hommes profondément réfléchés et exercés aux méditations métaphysiques." † The truth is, that when Bibliographers speculate in this field with a view to Catalogue making, they entirely forget their proper province and objects. They have nothing whatever to do with Genealogical Trees of knowledge, or with any mode of classing Books which is founded upon remote and arbitrary abstractions. The whole use and end of a Classed Catalogue is to furnish a ready index to Books, arranged according to their subjects; and

Bibliography. that arrangement is therefore to be preferred, which is founded upon the most obviously marked, and generally recognised divisions of those subjects. We may add, that to compile a good Catalogue of an extensive Library, even on this humbler plan, would require more ability, and more correctness of knowledge, than are often likely to be employed in such an undertaking.

Though we are not altogether satisfied with the division and order of the classes in the system commonly followed, we have no doubt, that by means of an additional class, and a correct arrangement of the subdivisions, a Catalogue might be formed, perfectly adequate to every useful purpose. We allude to a class, such as is partly indicated in the schemes both of Leibnitz and Middleton, for the reception of all Encyclopædical works, of Collections of treatises on various subjects, and Works of authors who cannot with propriety be limited to any one division of knowledge. M. Camus thinks, that the latter description of works may be properly enough entered in the class in which their authors most excelled; those of Cicero, for example, among the *Orators*; ‡ but, not to mention the evident incongruity of placing a collection, so multifarious as Cicero's works, under *Oratory*, there may sometimes be room for uncertainty, as to the division under which, according to this rule, an author's works ought to be sought. These incongruities and inconveniences, together with those which must arise from placing Encyclopædias, and General Collections, under any of the common divisions, can only be remedied by a *Miscellaneous Class*; and while this class ought to indicate, in one of its divisions, the Collective Editions of an author's works, his separate treatises ought to be entered under the subjects to which they belong; as, without this, the Classed Catalogue will not fully answer its purpose, of showing what has been written by the authors contained in it, on the different branches of knowledge. Thus, a Catalogue compiled upon this plan, would not only be rendered more consistent in its arrangement, but much more complete as an index to the materials of study.

IX. Of Bibliography in general.

It was our object in this article, to institute such a division of the general subject, as should enable us to point out the best sources of instruction and information in regard to all its branches; and in order to complete our view, we have still to notice some of those works which treat generally of all matters appertaining to Bibliography. We do not know any Book that presents a well written, judicious, and comprehensive digest of these matters; but there are several, nevertheless, which contain much curious and useful information in regard to them. 1. *The Introduction to the Knowledge of Books (Einleitung in*

* *Idea Leibnitiana Bibliothecæ Publicæ, Secundùm Classes Scientiarum Ordinandæ, fusior, et contractior.* Works, Vol. V.

† *Mém. de l'Institut.* Class, Litterat. et Beaux Arts, Tom. I. p. 488.

‡ *Mém. de l'Institut.* Tom. I. Litt. et Beaux Arts.

Bibliogra-
phy
Bichat.

Bucherkunde), by M. Denis, whose Supplement to Maittaire, and Bibliographical system, we have already mentioned, is of this description. The last edition, published at Vienna in 1796, consists of two volumes quarto. It has never been translated from the original German; and it is to be observed, that though it treats of the substances, forms, and classification of Books, it cannot be considered as a merely Bibliographical work, a large portion of it being devoted to the general History of Learning. The author, who was long principal Librarian of the Imperial Library at Vienna, died in 1808. In Germany he ranks high, not only as a Bibliographer and general Scholar, but as a Poet. He was the first who made his countrymen acquainted with the Poems of Ossian, by means of a poetical translation, which he published in 1768. His own poetry has much of the spirit and manner of the ancient Bards of the North; but he unfortunately chose hexameters for his translation of Ossian,—a form of verse not at all suited to the genius of the poetry which bears the name of that Bard. We are told, that his brother Poet, Alxinger, who died a year or two before him, had bequeathed his Head to augment the craniological stores and science of Dr Gall; a destination which Denis appears not at all to have relished for his own head, and to have feared that it might yet take it; for, by his testament, he enjoined his executors, in very positive terms, to see his body inhumed without dismemberment.* 2. *Manuel Bibliographique, ou Essai sur la connoissance des livres, des formats, des éditions, la maniere de composer une Bibliothèque, etc.*; par G. Peignot, published in 1800. 3. *Dictionnaire raisonne de Bibliologie, contenant l'explication des principaux termes relatifs a la Bibliographie; des notices sur les plus celebres Bibliographes; et l'exposition des differens systemes Bibliographiques*: in 3 vols. 8vo; by the same author. Bibliography is certainly indebted to this industrious compiler; but his vague and extravagant notions of its objects and rank have too often led him into confusion in his Books.

4. *Cours de Bibliographie, ou la science du Bibliothecaire*; par C. F. Achard, in 3 vols. 8vo, published at Marseills in 1807. The chief value of this compilation consists in its details of the different systems which have been proposed for classifying Books. We learn from the Introduction, that M. Francois de Neufchateau, when Minister of the Interior, gave orders that the Librarians of all the Departments should deliver Lectures on Bibliography; but that the plan, which indeed savours somewhat of *Bibliomania*, entirely failed; these Librarians having been found quite incapable to prelect upon their vocation. 5. *Introduction to the Study of Bibliography, to which is prefixed a Memoir on the public Libraries of the Ancients*; by Thomas Hartwell Horne, in 2 volumes 8vo, published at London in 1814. This, which is the only English Book of its kind, is chiefly translated and compiled from the French Bibliographical Works, and will be found useful to those who have not access to them. It contains full lists of Writers on Bibliography and Literary History; and the fullest account we have seen of Catalogues of Libraries both British and Foreign. The specimens of early Typography, and of the Vignettes and Monograms of the early Printers, are very neatly executed.

Bibliogra-
phy
Bichat.

We do not understand what this writer means, when he describes his Book as intended for "an Introduction to the *infant* Science of Bibliography." He seems to have allowed himself to be imposed upon, by the vague *verbiage* of those French Writers, who claim for this branch of knowledge a character of vastness which does not belong to it. Bibliography certainly presents a pretty wide field of inquiry, and in which there is yet room for many useful works; but it must appear evident from the details contained in the present article, that this field has in almost every part been long cultivated; if not always with perfect taste and judgment, yet with great industry, and so as to yield very profitable returns to the Commonwealth of Learning.

BICHAT (MARIE FRANÇOIS XAVIER), celebrated as an Anatomist and Physiologist, was born in France, at a village called Thoirette, on the 11th of November 1771. Great attention was paid to his education by his father, who was himself a physician, and who initiated him at an early age in those studies which were to prepare him more particularly for the profession to which he had destined him. He studied first at the College of Nantua, and afterwards at a seminary at Lyons; and was early distinguished for that activity of mind and facility in acquiring knowledge, which are the sure presage of great attainments at a mature age. In Mathematics

and the Physical Sciences more especially dependant on abstract reasoning, for which he showed a remarkable predilection, he made rapid progress. He afterwards became passionately fond of Natural History, and devoted all his time to this new study. He had already made considerable advances in this branch of science, as he had before done in Natural Philosophy and Mathematics, when his ardour was suddenly checked by the reflection that he was engaging in pursuits that were boundless in their object, and that were in danger of leading him too far from his future profession, through which alone he aspired at celebrity. Bidding a-

* *Biographic Universelle*, Tom. II. v. Denis

Bichât. dien, therefore, with a singular effort of resolution, to his favourite occupations, he applied himself at once with great diligence to the study of Anatomy and Surgery, under the guidance of Petit, who was chief-surgeon to the Hotel Dieu at Lyons. It is also curious that, some time after he had fully engaged in this course of instruction, he experienced a relapse of his passion for Mathematics to such a degree, that, yielding to the fascination, he resumed his early studies, in which, however, he had sufficient discretion to restrict himself within such limits as did not interfere with his medical pursuits. Petit soon discerned the superior talents of his pupil; and, although he had scarcely attained the age of twenty, employed him constantly as his assistant in his professional labours. The revolutionary disturbances, which raged with so much fury at Lyons, unfortunately interrupted his progress, in the midst of the flattering prospects which were opening to him: and flying from the horrors of the siege, which that devoted city was about to sustain, he took refuge in Paris, about the end of the year 1793. He there resumed the course of his professional studies, and became the assiduous attendant upon the Lectures of the celebrated Dessault; and in this, as in the former instance, became, in no long time, the companion and friend of his instructor. His merit was brought to the notice of Dessault by an accidental circumstance. It had been an established custom in the school, that the substance of the lecture of the preceding day was to be recapitulated, as an exercise, before the whole class, by one of the pupils, selected for this purpose. It happened one day that the pupil on whom this task devolved was absent at the time when he was expected to perform it, and the Professor asked if any one among his auditory would offer himself as a substitute. Bichât boldly came forward to volunteer his services, and acquitted himself to the admiration of all his hearers. The subject he had to explain was the theory and treatment of fractures of the clavicle. The exact analysis which he made of the instructions contained in the lecture, the copiousness and novelty of his illustrations, and the spirit of order and of method which characterized the whole of his exposition, joined to the modesty with which he stated some doubts, as well as some original views which he had taken of the subject, revealed at once the extent and vigour of his genius, and the expectations which might justly be entertained of his future eminence in his profession. Dessault, in particular, was strongly impressed with the superiority he had manifested over all his other pupils; and from that day he became an inmate in his house, and was treated in all respects as an adopted son. The opportunities which fortune thus placed within his reach were eagerly employed; and the favoured pupil showed himself worthy of the protection and confidence which he received. We find him, between the years 1793 and 1795, actively participating in all the labours of Dessault: visiting his patients both at the hospital and in private, accompanying him every where, as his assistant in his operations, and writing the greater part of his letters, in answer to those who consulted him from a

distance. His exertions by no means closed with the day; and he passed a great portion of the night in assisting to conduct the experimental researches on the diseases of bones, in which that able surgeon was engaged, and in consulting, previous to each lecture, the works of the ancient authors on the subjects to which they related. Whatever Dessault expressed a desire to have done, and he often required more than an ordinary person would have supposed it possible to perform, was sure to be accomplished within the requisite time by his indefatigable pupil. Notwithstanding these multiplied occupations, Bichât found means to prosecute his own researches in Anatomy and Physiology, to which he devoted every interval of leisure he could seize. The sudden death of Dessault, who was snatched from the world in the meridian of his fame, was a severe stroke of adversity to Bichât; but the event, though it deeply afflicted, did not discourage him: and though it might interrupt for a time, did not eventually relax his efforts at advancement. His first care seems to have been to acquit himself of the obligations he owed his benefactor, by contributing to the support of his widow and her son; and by conducting to a close the fourth volume of Dessault's *Journal de Chirurgie*. To this volume he subjoined a biographical memoir of its author, in which he pays a just tribute to his merit. His next object was to reunite and digest in one body the different surgical doctrines which Dessault had advanced in fugitive papers, published in various periodical works. Of these he, in 1797, composed a work, in two volumes octavo, entitled *Œuvres Chirurgicales de Dessault, ou Tableau de sa Doctrine, et de sa Pratique dans le Traitement des Maladies Externes*: a work in which, although he professes only to explain the ideas of another, he develops them with the clearness and copiousness of one who is in perfect possession of the subject which he treats. He was now at liberty to pursue the full beat of his genius, and soon arrived at those comprehensive and masterly views of Physiology, which, when afterwards developed in his writings, gained him so much applause. Undisturbed by the storms which agitated the political world, he pursued with steadiness the course he had meditated, and directed his more immediate attention to Surgery, which it was then his design to practise. We meet with many proofs of his industry and success, at this period, in the *Recueil de la Société Médicale d'Emulation*, an association of which Bichât was one of the most zealous and active members. Three memoirs which he communicated, were published by the Society in 1796; the first, describing an improvement in the instrument for trepanning; the second, detailing a new process, which he devised for the ligature of polypi; and the third, in the distinction to be observed in fractures of the clavicle, between those cases requiring the assistance of art, and those in which its interference would be of no avail. In 1797, we find him undertaking the arduous task of instructing others, which he commenced by a course of anatomical demonstrations. Not expecting any great number of pupils, he had hired a small room for the purpose; but his merit as a

Bichât. teacher soon attracted a crowd of auditors; he was obliged to enlarge his theatre, and was also encouraged to extend the plan of his lectures, and to announce what had hitherto never been attempted by one so young and inexperienced, a course of operative surgery. If the boldness of the enterprise was calculated to excite surprise, his success in the execution of it was still more astonishing. His reputation was now fully established, and he was ever after the favourite teacher with the students who resorted to the capital. In the following year, 1798, he gave, in addition to his course on Anatomy and operative Surgery, a separate course of Physiology. But the exertion of speaking, which these numerous courses of lectures, all of which he conducted at the same time, required, was more than his frame could bear; and a dangerous hæmoptysis, with which he was seized in the midst of his labours, obliged him to interrupt them for a time, and warned him that there are limits to human strength. But the danger was no sooner passed, than the lesson seems to have been disregarded; for we find him plunging into new engagements with the same ardour as before. He had now scope in his physiological lectures for a fuller exposition of his original views in the animal economy, which were no sooner made known to his pupils, than they excited much attention in the medical schools at Paris; and he was induced to publish them in a more authentic form. Sketches of these doctrines were given by him in three papers contained in the Memoirs of the *Société Médicale d'Emulation*. The first is on the synovial membranes; in which he gives a more clear description of the organ that secretes synovia, a fluid, the origin of which had been a matter of much controversy. The next contains an account of the membranes of the human body in general, which he considers apart from the organs they invest and support, and which they serve to supply with vessels; and regards as performing offices in the economy distinct from those of the organs with which they are so connected. His last memoir relates to the symmetry, which is so remarkable a feature in all those parts of the body that are the instruments of the animal functions, and which establishes so exact a similarity between the limbs and organs of sense on each side of the body; while, on the other hand, no such regularity can be traced in the forms and dispositions of the viscera, which, like the heart, the stomach, liver, and other organs of assimilation, are subservient to the vital functions. He even assumes this difference as the foundation of a marked distinction between these two classes of functions; the one, being common to all organized beings, he denominates organic; the other, as exclusively pertaining to animality, he denotes by the name of animal functions. The doctrines contained in these memoirs were afterwards more fully developed in his *Traité sur les Membranes*, which appeared in 1800, and which immediately drew the attention of the medical world both at home and abroad. Some time previous to this, he gave to the public a small work, in which he endeavoured to bring together, in a condensed form, the lessons of Dessault relative to the

diseases of the urinary passages; in the notes to this volume, we may perceive the germ of many of those views which were peculiar to Bichât.

His next publication was the *Recherches Physiologiques sur la Vie et sur la Mort*, in 1800, which consists of two distinct dissertations. In the first, he explains at still greater length than he had previously done, his classification of functions, and is at pains to trace the distinction between the animal and organic functions in all its bearings. In the second, he investigates the connection between life and the actions of the three central organs, the heart, lungs, and brain, on which its continuance so essentially depends. But the work on which he bestowed the most attention, and which contained the fruits of his most profound and original researches, is the *Anatomie Générale*, which was published in four volumes octavo in 1801. It is founded on his classification of the parts of the body, according to their intimate structure; in order to establish which, he decomposes the animal machine, not merely into the larger pieces of which it is formed, but into the organic elements that constitute them. Of these elementary parts or textures, as he terms them, into which every organ may be ultimately analyzed, he enumerates twenty-one different species. He conceives each of these textures to possess a peculiar modification of vitality, from which it derives those properties that distinguish it from dead matter, and that give rise to all the phenomena of the animal economy, both in a healthy and diseased state.

Before Bichât had attained the age of eight-and-twenty, he was appointed physician to the Hotel Dieu, a situation which opened an immense field to his ardent spirit of inquiry. In the investigation of diseases, he pursued the same method of diligent observation and scrupulous experiment, which had characterized his researches in physiology. He learned their history, not from books, but by studying them at the bedside of his patients, and by accurate dissection of their bodies after death. He engaged in a long series of examinations, with a view to ascertain the exact changes induced in the various organs by diseases, which he conceived, in every instance, primarily to affect some one of their constituent textures, while the rest did not suffer any change, unless by the supervention of some other disease. In the prosecution of these inquiries, he had, in less than six months, opened above six hundred bodies. As intimately connected with the practical exercise of the healing art, he was anxious also to determine, with more precision than had hitherto been attempted, the effects of remedies on the body. It must be confessed, that our knowledge of the operation of remedies is, for the most part, extremely vague and conjectural; and it appeared to him an object of great importance to rescue this branch of science from the uncertainty in which a multitude of points relating to it were still involved, by applying to it the same methods of inductive reasoning as have, in other sciences, been attended with so much success. The basis of the inquiry was to be laid by collecting a sufficient number of facts to admit of their being compared and generalized. A large hospital could

Bichât
Bilfinger.

alone furnish the means of conducting such an investigation; and Bichât eagerly availed himself of the opportunities which his appointment at the Hotel Dieu now afforded him, of instituting on these subjects a series of direct experiments on a very extensive scale. He began by giving singly different medicinal substances, and then watching attentively the phenomena that ensued. He then united them in various ways, first joining two together, then three, and so proceeding to more complicated combinations; and observed the particular changes in their mode of operating, which resulted from their being thus combined. So wide a range of experiments, it is evident, could not have been conducted without assistance; and he selected forty of his young pupils to aid him in collecting the requisite observations. He had already, in this way, procured a vast store of valuable materials for his course of Lectures on the *Materia Medica*, the completion of which was unfortunately prevented by his untimely death; but a great part of the facts were subsequently published in the inaugural dissertations of his pupils. Latterly, he had also occupied himself with framing a new classification of diseases.

During these arduous vocations, he never lost sight of his anatomical pursuits, and had commenced a new work on the subject, in which the organs were arranged according to his peculiar classification of their functions, under the title of *Anatomie Descriptive*. He lived only to publish the two first volumes of this work. It was, however, continued on the same plan, and completed in three volumes more, by Messrs Buisson and Roux, who had been his most active assistants, and who appear to have been perfectly master of his ideas on the subject. His death was brought on by a fall from a staircase at the Hotel Dieu; and although the accident did not at first appear serious, it excited so great a degree of fever, that his frame, already exhausted by excessive labour, and enfeebled by constantly respiring the tainted air of the dissecting-room, in which he had latterly passed the greater part of his time, sunk under the attack. He died July 22, 1802, universally regretted by his pupils, and attended to the last by the widow of his benefactor, from whom he had never been separated. Every tribute of respect was paid to his memory; his funeral was attended by above six hundred of his pupils, and by a number of the Physicians in Paris. His bust, together with that of Dessault, was placed at the Hotel Dieu by order of the First Consul, in joint commemoration of the man under whose fostering protection so bright a genius was first brought before the public, and of the pupil who nobly emulated the fame of so great a master. We cannot, indeed, refrain from admiration, when we contemplate all that Bichât has done in his profession in so short a period of time, nor sufficiently lament that a career so auspiciously begun, should, at the age of thirty, have been so suddenly and prematurely terminated. (w.)

BILFINGER (GEORGE BERNARD), born 23d January 1693, at Canstadt in Wurtemberg, acquired considerable celebrity as a Philosopher and Statesman. His father was a Lutheran minister. By a singularity

of constitution, hereditary in his family, Bilfinger came into the world with twelve fingers on his hands, and twelve toes. An amputation happily corrected this deformity. Bilfinger, from his earliest years, discovered the greatest inclination to learning, and made himself remarkable by his fondness for meditation. He studied in the schools of Blanbeuern and Bobenhausen, and afterwards entered into the Theological Seminary of Tubingen. The works of Wolf, which he studied in order to learn Mathematics, soon inspired him with a taste for the Wolfian Philosophy, and that of Leibnitz; a passion which made him neglect, for some time, his other studies. Returning to Theology, he wished, at least, to try to connect it with his favourite science of Philosophy, and in this spirit composed a tract, entitled, *De Deo, Anima, et Mundo*. This work, filled with new ideas, met with great success, and contributed to the advancement of the author, who was appointed soon after to the office of Preacher, at the Castle of Tubingen, and of Reader in the school of Theology: but Tubingen was now become too small a theatre for him. He obtained from his friends, in 1719, a supply of money which enabled him to spend some time at Halle, in order to pursue the lessons of Wolf, and after two years of study, he returned to Tubingen, where the Wolfian Philosophy was not yet in favour. He found his protectors there cooled, saw his lectures deserted, and perceived himself shunned, from the dislike of his new doctrines: his ecclesiastical views also suffered from it. This unpleasant situation lasted almost four years, when he received, by the intervention of Wolf, an invitation to go to Petersburg, where Peter I. wished to appoint him Professor of Logic and Metaphysics, and member of his new Academy. He was received in this city, where he arrived in 1725, with the consideration due to his abilities. The Academy of Sciences of Paris having proposed, about this time, the famous problem, on the cause of Gravity, Bilfinger gained the prize, which was a thousand crowns. The reputation of this success was spread abroad among all the learned of Europe. All the journals repeated it; and the Duke Charles Edward of Wurtemberg, finding that the author of this admired Memoir was one of his subjects, hastened to recal him into his dominions. The court of Russia, after having made some useless attempts to detain him, granted him a pension of four hundred florins, and a present of two thousand, in reward of an invention relative to the art of fortification. He quitted Petersburg in 1731. Returned to Tubingen, Bilfinger soon excited considerable attention in that quarter, both by his own lectures, and by the changes which he introduced in the school of Theology. The whole University prospered under his care; and this establishment is conducted to this day according to his excellent regulations. Without overturning any thing in the foundation of Theology, he succeeded in applying his system of Philosophy to this science, exhibiting, it is said, in his deductions, and in his proofs, a method, a justness, and a clearness, which bespoke a mind long exercised in deep and rigorous investigations. The Duke Charles Alexander, who succeeded

Bilfinger. Edward, had already had occasion to appreciate his talents, and put them to use. At the time when he carried on the war in Servia, he maintained a regular correspondence with Bilfinger, who had long been known as an able Engineer, and had, indeed, made some improvements of value in the received system of Fortification. After his return to Tubingen, he had frequent conversations with the Professor on different subjects of administration, and appointed him; in 1735, Privy-Counsellor. This nomination was not a simple honorary title. Bilfinger saw himself raised at once to a power almost unlimited. He resisted some time a promotion, which he did not think himself qualified to sustain. In accepting office, his first care was to acquire all the knowledge necessary to the discharge of its duties. He employed almost two years in assiduous labour to instruct himself thoroughly in the statistics of the country, in considering its political situation, its constitution, its interests, and became, at the end of all this study, one of the most enlightened ministers that his country had yet produced. Bilfinger was placed in a situation too elevated not to excite jealousy and hatred. He felt it, and wished to quit the ministry; but the court refused to receive his resignation, soon after the tender of which, the Duke died. Bilfinger experienced from his successor all the consideration and all the friendship which he had experienced in the beginning of his career. Received into a confidence without bounds, he had the power to realize, without obstacle, those plans of administration with which the most enlightened patriotism had inspired him. Wurtemberg still feels the happy influence of his ministry. Commerce, public instruction, agriculture, were protected and ameliorated by his cares. The culture of the vine, of so much importance in this country, was one of the principal objects of his attention. We ought not to forget that he was the original author of that strict union which has long united Wurtemberg and Prussia, and of the importance to which the hereditary Prince of Wurtemberg was raised at the court of Berlin. In 1737, the Duke nominated him President of his consistory, and Secretary of the grand Order of the Chace. He was also Curator of the University of Tubingen, and member of the Royal Academy of

Berlin. All his time was consecrated to some serious occupation, with the exception of one hour in the evening, which he employed in making and receiving visits. His greatest enjoyment was in cultivating his garden. A warm and strong friend, he gave many proofs of gratitude to those protectors, who had generously assisted him in his studies. He has been reproached with being irascible; but in spite of some slight blemishes, the memory of Bilfinger will be always dear to his countrymen, and honoured by all Germans. Wurtemberg reckons him among the greatest men which she has produced, and proposes him as a model to her statesmen and her men of letters. He was never married, and left no issue. He died at Stuttgart the 18th of February 1750. His works, besides various Papers published in the Memoirs of the St Petersburg and Paris Academies of Science, are :

1. *Disputatio de Harmoniâ præstabilitâ*, Tubingen, 1721, in 4to.
2. *De Harmoniâ Animi et Corporis Humani maxime præstabilitâ Commentatio Hypothetica*, Francfort on the Main, 1723, in 8vo. This work was inserted in the Expurgatory Index at Rome in 1734.
3. *De Origine et Permissione Mali, præcipuè Moralitatis, Commentatio Philosophica*, ibid. 1724, in 8vo.
4. *Specimen Doctrinæ Veterum Sinarum Moralis et Politicæ*, Francf. 1724, in 4to.
5. *Dissertatio Historico-cataptrica de Speculo Archimedis*, Tubingen, 1725, in 4to.
6. *Dilucidationes Philosophicæ de Deo, Animi Humanâ, Mundo, et Generalibus Rerum Affectionibus*, ibid. 1725, in 4to.
7. *Bilfingeri et Holmanni Epistolæ de Harmoniâ Præstabilitâ*, 1728, in 4to.
8. *Disputatio de Naturâ et Legibus Studii in Theologiâ Thetici*, ibid. 1731, in 4to.
9. *Disputatio de Cultu Dei Rationali*, ibid. 1731.
10. *Notæ Breves in Ben. Spinosa Methodum Explicandi Scripturas*, Tub. 1732, in 4to.
11. *De Mysteriis Christianæ Fidei Generatim Speculatis Sermo, Recitatus* 1732, Tubingen, 1732, in 4to.
12. *Elementa Physices*, Leipzig, 1742, in 8vo.
13. *La Citadelle Coupée*, Leipzig, 1756, in 4to.

See *Biographie Universelle*, Tom. IV. (z.)

BILLS OF MORTALITY.

Bills of Mortality.

BILLS OF MORTALITY are abstracts from parish registers, showing, as their name imports, the numbers that have died in any parish or place during certain periods of time, as in each week, month, or year; and are, accordingly, denominated weekly, monthly, or yearly bills. They also include the numbers of the baptisms during the same periods, and generally those of the marriages.

What has been advanced on this subject, under the head **MORTALITY, BILLS OF**, in the *Encyclopædia*, appears to have been taken from Dr Price's *Observations on Reversionary Payments*; and is designed principally, to explain the method of constructing *Tables of Mortality* from such *Bills*, which shall exhibit the law according to which human life wastes at every age, and shall enable us to determine readily, the probability of its continuance from any one age to any other; a subject which will be treated in this *Supplement* under the head **MORTALITY, LAW OF**.

Objects of this Article.

The objects of the present article are these:— First, to give a brief history of the principal things that have been done in this way, which may suffice for such as are not disposed to go further into the subject, and may, at the same time, indicate the best sources of information to those who take more interest in it.

As both mortuary registers and enumerations of the people are much more valuable when combined than when separate, we shall also notice some of the principal enumerations, the results of which have been published. We shall then point out some of the principal defects in most of the published registers and enumerations; and, lastly, shall submit some forms, according to which, if enumerations be made, and registers kept, they will be easily convertible to useful purposes.

History.

The ancients do not appear to have kept any exact mortuary registers, at least no account of any registers of that kind, with the ages of the deceased, have come down to us; and although, in the Roman *Census*, first established by **SERVIVS TULLIVS**, both the ages and sexes of the people were distinguished, we have no exact account of these particulars in any one of their enumerations.

Indeed, the principal object of the *census* among that warlike people, was the levying of men and money for the purposes of conquest; the duration of human life appears to have occupied very little of their attention, and their proficiency in the science of quantity was not sufficient either to show them what the necessary *data* were, or to enable them to draw just inferences from them, had they been in their possession.

A good account of what the ancient Romans did in this way, with references to the original authorities, may be found in the Italian translation of M. Demoivre's *Treatise of Annuities on Lives*, by Gaeta

and Fontana, which was published at *Milan*, in 8vo, in the year 1776. (*Discorso Preliminare, Parte 2.*) *Bills of Mortality.*

The keeping of parish registers commenced in England in the year 1538, in consequence of an injunction issued in that year by Thomas Cromwell, who, after the abolition of the Pope's authority in this kingdom, in the reign of Henry VIII., had been appointed the King's vicegerent in ecclesiastical affairs.

Some parish registers in Germany appear to have commenced with the sixteenth century; and in the *Göttliche Ordnung of Süsmilch* (T. 3. S. 23.), we are informed, that at the time of Lord Cromwell's injunction, they had already old registers of that kind, both at Augsburgh and Breslaw. However, the extracts he has given from the Augsburgh registers do not go back further than the year 1501, nor those for Breslaw beyond 1555. About the beginning of the seventeenth century, such registers appear to have been established in most parts of Europe; but it was not until the year 1662 that they began to attract public notice, and to be considered as the sources of valuable and interesting information. In that year, John Graunt, a citizen of London (afterwards an officer in the trained bands of the city, and a Fellow of the Royal Society), published his *Natural and Political Observations on the Bills of Mortality*, principally those for London. *Mr Graunt.*

The London bills, or accounts of baptisms and burials, appear to have been occasioned by the plague, and to have been begun in the year 1592, a time of great mortality. They were afterwards discontinued, but were resumed in 1603, after the great plague of that year. They have ever since been continued weekly, and an annual bill also has been regularly published. In 1629, the number of deaths by the different diseases and casualties, were first inserted in them, also the distinction of the sexes; and these have been continued ever since. But it is in the totals only of the baptisms and burials that the sexes are distinguished in these bills. They do not show how many of each sex died of each disease, neither have they, since 1728, when the distinction of the ages of the dead was first introduced, shown how many of each sex died in each interval of age, but only the total number of both sexes.

This book of Graunt's, although the first, is also one of the best that have been published on the subject. It contains many judicious observations on the imperfections of the bills, on the proportions of the deaths from different diseases and casualties, and on their increase and decrease, with the probable causes of such fluctuations. He also observed, that "the more sickly the years are, the less fecund or fruitful of children also they be."

Besides the London bills, he gave one for a country parish in Hampshire, in the first edition of his

Bills of Mortality. book; and, in an appendix to the later editions, two others, one for Tiverton, the other for Cranbrook in Kent, with a few observations on foreign bills. He almost always reasons justly from his data; but, as these were very imperfect, in his endeavours to draw more information from them than they could supply, he has sometimes fallen into error.

Even in this enlightened age, when a much greater proportion of the people devote a portion of their leisure to the acquisition of knowledge than in Graunt's time, subjects of this kind have but few attractions for the generality even of reading men, who cannot endure the fatigue of thinking closely for any length of time. The author, accordingly, expected his readers to be rather select than numerous, and was ambitious of that distinction, as appears by the motto he prefixed to his work,

— Non, me ut miretur Turba, laboro,
Contentus paucis Lectoribus. —

The book was, however, favourably received by the public, and went through five editions in fifteen years, the two first in 4to, the three others in 8vo; the last of them, published in 1676, two years after the author's death, was edited by his friend, *Sir William Petty*, who, in consequence of having sometimes spoken of this edition as his own, has by some writers been erroneously considered as the author.

Graunt's observations, like all others of a similar kind, by showing the usefulness of parish registers and bills of mortality, contributed to form a taste for these inquiries among thinking men; and, consequently, to improve both the registers and the bills derived from them; so that, from his time, the subject has been continually cultivated more and more. Parish registers, in most parts of Europe, have been kept with more care; and a succession of works of considerable merit have been published on the subject, containing an important part of the natural and political history of our species, and affording valuable materials for the science of political economy.

The principal of these works we proceed to give a short account of, in the order of their publication.

As the ages at which the deaths took place were not inserted in the London bills till 1728, Captain Graunt could not avail himself of that important information, but made a fruitless attempt to determine the law of mortality without it.

Dr Halley

The Breslaw bills appear to have been the first wherein the ages at which the deaths took place were inserted, and the most important information which Bills of Mortality can afford, was first drawn from them by Dr Halley; who, in 1692, constructed a table of mortality for Breslaw from these bills for the five preceding years, and inserted a paper on the subject in the *Philosophical Transactions*, No. 196.

Dr Davenant and Gregory King.

In 1699, Dr Davenant, in *An Essay upon the probable Methods of making a People Gainers in the Ballance of Trade*, published some extracts from *Natural and Political Observations and Conclusions upon the State and Condition of England*, by permission of their author, Gregory King, Esq. Lancaster Herald, who had completed them in 1696, though

they still remained in manuscript; and the whole of this very curious production was published by Mr Chambers at the end of his *Estimate* in 1802. Mr King derived his information from the poll-books; from actual observations in particular places; from the assessments on marriages, births, and burials; and from the parish registers. Many of his conclusions agree surprisingly well, considering the time he wrote, with those which are the results of a hundred years of further observations and inquiries. He had access to much better data than Graunt, and his conclusions are more accurate; but he does not explain so fully how he arrived at them.

Bills of Mortality.

From the publication of Davenant's essay, above M. Kerseboom mentioned, nearly forty years had elapsed without any thing further being done in this way, when M. Kerseboom published an essay, in the Dutch language, on the probable number of people in Holland and West Friesland, which he deduced from the Bills of Mortality (Hague, 1738, 4to); and two others in 1740 and 1742: an account of the first of these three essays may be seen in the *Philosophical Transactions*, No. 450, and of the two others in No. 468.

In 1742 was published the first edition of the celebrated work, entitled *Die Göttliche Ordnung in den Veränderungen des menschlichen Geschlechts aus der Geburt, dem Tode und der Fortpflanzung desselben erwiesen von Johann Peter Süssmilch*. The second edition appeared in 1761, enriched with the materials which had been laid before the public through various channels in the interim; the third in 1765, and in 1775 a fourth edition of the two volumes of Süssmilch was published by Christian Jacob Baumann, to which this editor himself added, in 1776, a third volume, consisting of additions to the other two, and remarks upon them, with many new tables, and a copious index. The last edition of this work was published in 1798, but it does not appear to have been augmented or improved since 1776. It contains long dissertations on every thing not mathematical connected with the subject, and, besides original information, includes the substance of all the other publications on it previous to 1776; with an immense collection of materials, which, when borrowed, are often better arranged and rendered more convenient for reference, than they will be found to be in the works they were extracted from; besides, the original sources of information are always referred to, and these advantages, with that of a full index, render it a valuable work for occasional reference. The three thick 8vo volumes contain upwards of 2300 pages, closely printed with a small type, and the tables alone occupy 330 pages.

In 1746 was published the *Essai* of M. Deparcieux, which has been already mentioned in the historical introduction to the article ANNUITIES in this Supplement: information much wanted on this subject, was there given in a very clear and popular manner, and the work no doubt contributed greatly to the advancement of the science. It probably had some influence in promoting the establishment of what is called the *Tabellvärket* in Sweden, which

Bills of Mortality.

Dr Short.

took place in 1749, and of which we shall have occasion to take further notice presently.

In 1750 appeared, in 8vo, *New Observations natural, moral, civil, political, and medical, on City, Town, and Country Bills of Mortality; to which are added, large and clear Abstracts of the best Authors who have written on that subject; with an Appendix of the Weather and Meteors*, by Thomas Short, M.D. which he had "had on the anvil" for eighteen years, as he informs us in the Preface to his *History of Air, Weather, &c.* This author, with incredible labour, collected extracts from the mortuary and baptismal registers in a great many market-towns and country parishes in England, chiefly in the northern counties, in almost every variety of soil and situation, and reduced them into tables in various ways, so as to enable him to draw useful inferences from them.

He informs us that Lord Cromwell's injunction in 1538 was but little regarded in many places till the year 1559, when another was issued for the same purpose by Queen Elizabeth; nevertheless, he had procured several exact country registers, commencing with 1538, and continued, without one chasm, for more than two hundred years; and the registers before 1644, he considered to be much more valuable than afterwards, on account of the increase of dissenters from that time. He likewise procured both the numbers of families and of souls in seven of the market-towns, and fifty-four of the country parishes, for which he had registers; and thus arrived at satisfactory information on several points, which, till then, had been very imperfectly understood. But the sexes were not distinguished in his enumerations; neither were the ages, in any of the enumerations or registers he has given accounts of, except in the London Bills of Mortality, and what he has taken from Dr Halley, respecting those for Breslaw.

Although Dr Short took so much trouble in collecting materials, and has generally reasoned well upon them, he has shown but little skill, and does not appear to have taken much pains in communicating his information to his readers; so that it costs them considerable labour to find what they want, especially in his tables; and when found, to understand it.

Mr Morris.

In 1751 was first printed a tract by Corbyn Morris, entitled, *Observations on the past growth and present state of the City of London*, with the most convenient and instructive tables of the London bills that have been printed: they contained the annual baptisms and burials from the year 1603, the number of annual deaths by each disease from 1675, and of each age from 1728; all brought down to the year 1750. This tract was reprinted in 1758, with a continuation of the tables to the end of 1757; these also contain useful annual averages and proportions. Mr Morris's observations are generally very judicious, but he was one of those authors who appear to have laboured under much misconception with regard to the evils to be apprehended from the mortality of London, and what they considered to be its baneful effects in drawing recruits from the country. These writers did not perceive, or did not sufficiently consider, that the natural procreative power is much

more than adequate to supply any waste of that kind, and that the real obstacle to the increase of the people, is the limited means of subsistence. This had been observed by Dr Halley in his *Further Considerations on the Breslaw Bills of Mortality* (*Phil. Trans.* 1693), though it there also appears, that he had not sufficiently considered the mode of its operation: this was first fully illustrated by Dr Franklin in his excellent *Observations on the Increase of Mankind, Peopling of Countries, &c.* written in Philadelphia in 1751, the same year in which Mr Morris's pamphlet was first published. The author also pointed out in that pamphlet, material defects in the Bills of Mortality, and proposed a better method of keeping them, not only in London, but throughout the kingdom. This gave occasion to a paper by Mr James Dodson, which was inserted in the *Philosophical Transactions* for that year (1751), wherein he showed the importance of their being so kept as to afford the means of valuing annuities on lives, and proposed other alterations which appeared to him calculated to fit them for the purpose.

Nicolaas Struyck of Amsterdam, who, in his *Introduction to General Geography*, published there in 1740, had inserted (*Gissingen over den staat van 't Menschelyk Geslacht*) *Conjectures on the State of the Human Species*; published at the same place in 1753, a quarto volume, the first half of which is astronomical, the other (216 pages) is entitled (*Nader Ontdekkingen noopens den staat van het Menschelyk Geslacht*), *Further Discoveries concerning the State of the Human Species*. It contains statements of actual enumerations of the people in many Dutch villages, principally in North Holland, wherein the sexes are distinguished, and the numbers in childhood, celibacy, marriage, and widowhood; but with respect to their ages, it is only stated for each sex, how many were under ten years, and how many of the unmarried were above that age; except in two instances, wherein the number of each sex is given in each interval of five years of age, from birth to the extremity of life: they amount altogether to 2728, of whom not one was above the age of 85, and only four above 80.

He generally gives, for each place, the names and professions or occupations of the persons who made the enumeration, and the precise day on which it was made; or if it occupied the parties more days than one, those on which it was commenced and completed are given; a practice which shows a laudable solicitude about particulars, and a title to our confidence, the want of which we have great cause to lament in too many other writers.

Extracts from many parish registers are also given; in these, too, the ages are seldom noticed; but in a few cases they are given very minutely, especially in that of Westzaandam, for which, the numbers who died in each interval of five years of age, from birth to the extremity of life, are given; also the number in each year of age under fifteen, the number in each month of the first year of age, even the number that died in the first hour from birth, in the first twenty-four hours, and in each day of the first week of their age. During a term of nineteen years, the whole number of deaths thus registered was 3328;

Bills of Mortality.

Mr Dodson.

Nicolaas Struyck.

Bills of
Mortality.

but the sexes were not distinguished under fifteen years of age, which Struyck himself lamented. The work also contains much information respecting the population and parish registers of *Amsterdam, Haarlem, &c.* with some accounts of other countries, and of other works on the subject.

Dr Birch.

In 1759 was published, at London, in 4to, *A Collection of the Yearly Bills of Mortality, from 1657 to 1758 inclusive, together with several other Bills of an earlier date*; to which were subjoined Captain Graunt's *Observations*; *Another Essay in Political Arithmetic*, by Sir William Petty; the *Observations of Corbyn Morris, Esq.*; and *A Comparative View of the Diseases and Ages, with a Table of the Probabilities of Life for the last thirty years*, by J. P. Esq. F. R. S. This is a valuable compilation, and has been generally attributed to Dr Birch, the Secretary and Historian of the Royal Society; the preface is very judicious, and contains a good deal of information. For the following history of this publication, the author of the present article is indebted to the kindness of Dr Heberden:—

“The bills were collected into a volume by his father, the late Dr Heberden. He procured likewise, observations from several of his friends, rectors of some large parishes, or others likely to give him information; particularly from Bishop Moss, Bishop Green, Bishop Squire, and Dr Birch. These, together with some of his own remarks, were thrown into the form of a preface; and the whole was committed to the care of Dr Birch. To make the calculations which appear at the end of the book, Dr Heberden employed James Postlethwayt, Esq. a very distinguished arithmetician.”

M. Messance.

In the year 1766, this branch of knowledge was enriched with new materials, of more value than all that had previously been laid before the public. These were contained in three publications, of which we shall first notice the *Recherches sur la Population des généralités d'Auvergne, de Lyon, de Rouen, et de quelques Provinces et Villes du Royaume*. Par M. Messance, Receveur des Tailles de l'Élection de Saint Etienne.

Most of the political writers in France, for some years previous to the date of this publication, had asserted confidently that the kingdom was depopulated, but without producing any proofs. The object of M. Messance was, to enable his readers to judge of the merit of such assertions, and to pronounce less vaguely on a subject in itself so interesting, the knowledge of which can only be obtained by a great number of facts and actual observations. The work, accordingly, is filled with tables, exhibiting the results of actual enumerations of the people, and of extracts from the parish registers. They show, for each sex, how many were under 14, or in celibacy above that age; those in the states of marriage and of widowhood; and the number of domestic servants. The numbers of families are also stated; and the enumerations of the ecclesiastics, properly classed, are given separately; but no other information respecting the ages of the living is given than that mentioned above. A great many statements are also inserted of the numbers that died in

Bills of
Mortality.

different parishes, and more extensive districts, under 5 years of age, between 5 and 10, and in each interval of 10 years, from thence to the age of 100; during different periods of from 10 to 40 years, or more, generally ending about the year 1760; but in these the sexes are not distinguished.

In all cases, he has given the general results of his tables, and the proportions they afford, very distinctly stated; and among these results, the increase of the population during the preceding 60 years, to which his researches were generally limited, is clearly ascertained.

The work also contains many interesting tables, in which the rate of mortality, and the produce of manufacturing labour, are compared with the contemporaneous prices of grain, in various places, generally for periods of 20 years each.

In the same year was published, at Yverdon, in M. Muret; 8vo, the work entitled *Mémoire sur l'état de la Population, dans le Pays de Vaud, qui a obtenu la prix proposé par la Société économique de Berné*. Par M. Muret, premier Pasteur à Vevey, et Secrétaire de la Société Économique de Vevey.

The Pays de Vaud contains 112 parishes, and the population at that time was about 118,000 souls. M. Muret wrote for information to all the clergymen in the country, who made him returns of the numbers of baptisms and burials in their respective parishes, for different periods, from 10 to 40 years, in many of which both the ages and sexes were distinguished; and from about two-thirds of them he obtained also the numbers of marriages and families actually subsisting; also the number of souls, “or at least of communicants,” in their parishes: but neither the ages nor sexes were distinguished in any of the enumerations of the living.

This performance does much credit both to the author's industry and judgment, but it has also material defects. He gave upwards of 50 tables, by which he intended to show the probabilities and expectations of life till five years of age, and at every fifth year after that, in different parishes and places, under various circumstances of soil and situation, and for people of different habits and occupations; also for the two sexes separately. These must have cost him a good deal of labour, and would have been extremely valuable had they been correct; but, unfortunately, he did not understand the construction of such tables, and they are not to be depended upon. He also took considerable pains to determine the rates of mortality among married and single women, considered separately, and thought he had proved that it was less among the married; but the proofs he adduced were not conclusive. Some of his observations on the state of the population, and the plans he recommended for increasing it, also show, that he did not understand the principle on which its progress depends.

It is with much reluctance that we make, on so respectable an author, remarks which apply equally to almost all his predecessors in these inquiries; but this we consider to be rendered necessary, by the *Mémoire* generally, and the Tables in particular, having been praised for their extreme accuracy, in a

Bills of Mortality.

very good abridgment of them, inserted in the second volume of a book, entitled *De Re Rustica, or the Repository*, 8vo, London, 1770.

The disadvantages of her soil and climate necessarily keep Sweden thinly peopled in comparison with the countries which, in these respects, are more happily circumstanced; and since the year 1748, the state of the population has been an object of anxious solicitude with the government; which, in 1749, established what, in this country, would probably be called a Board of Population (but is there denominated *Tabellväarket*), for reducing into convenient forms the extracts from the parish registers, and the returns from the magistrates of the numbers of the people, which the governors of the different provinces are required to state to the commissioners appointed for these purposes. The extracts from the registers are made and transmitted annually, but the enumerations only once in three years.

Printed forms, with proper blanks, distinguishing the ages and sexes, both of the living and the dead, with the diseases the deaths were occasioned by, are distributed throughout the country, to enable the people to make these returns correctly and uniformly; and the information thus acquired, respecting the state of population and mortality, is much more correct and satisfactory than what has been obtained in any other place of considerable extent; but from causes which we have not room to explain here, the results were not laid before the public until some years after the returns were made.

M. Wargentin.

M. Wargentin, who was one of the Commissioners of the *Tabellväarket*, inserted in the *Transactions of the Royal Academy of Sciences at Stockholm, for the years 1754 and 1755*, papers on the usefulness of annual registers of births and deaths in a country; which, like all his other productions, were written with much judgment and modesty; but, to illustrate the subject, he was generally under the necessity of borrowing materials from the writings of others; as, at that time, he was only in possession of the results of the Swedish returns for the single year 1749. In the same *Transactions*, for the year 1766, he inserted a paper on the mortality in Sweden, wherein he gave tables exhibiting the number of the living of each sex in each interval of age, in the years 1757, 1760, and 1768; also the number of annual deaths of each age and sex during a period of nine years, commencing with 1755, both for all Sweden and Finland, and for Stockholm separately; with other interesting results of the registers and enumerations, and many judicious observations upon them.

This paper of M. Wargentin's is more valuable than all that had previously been published on the subject; it is also to be found in the French abridgment of the *Stockholm Transactions*, in the eleventh volume of the *Collection Académique (partie étrangère)*, which abridgment was also published separately, at Paris, in 1772.

In 1767, Dr Short published, in 4to, *A Comparative History of the Increase and Decrease of Mankind*, in which the tables are printed more intelligibly, and there is more information respecting foreign Bills of Mortality, than in his *New Observations*.

Dr Price.

The first edition of Dr Price's *Observations on*

Reversionary Payments appeared in 1771, and contained "observations on the expectations of lives, the increase of mankind, the number of inhabitants in London, and the influence of great towns on health and population," which had been published in the *Philosophical Transactions* for 1769, and added considerably to the information on those subjects which had been previously before the public; also observations on the proper methods of constructing tables of mortality, mentioned at the commencement of this article, and which we shall have occasion to notice again.

In the *Philosophical Transactions* for the years 1774 and 1775, were inserted two excellent papers by Dr Haygarth of Chester, wherein he gave the Bills of Mortality for that city, for the years 1772 and 1773 respectively, in a form calculated to exhibit, at one view, the most useful and interesting information such bills can afford without calculation, and presenting to the calculator data that are essential to the solution of the most important questions respecting the state of the population. Three papers by Dr Percival (also of considerable merit) appeared in the same *Transactions* about this time, relating principally to the population of Manchester and its neighbourhood.

In 1778 was published, at Paris, in 8vo, the work M. Moheau, entitled *Recherches et Considérations sur la Population de la France*, par M. Moheau. This book is agreeably written, in a way entirely popular, and will probably be perused with more pleasure, therefore, also with more profit, by the generality of readers, than any other on the subject of population. It contains a great number of tables, for many of which he was indebted to other writers, especially to M. Messance; but he has also given many that are original, derived from the Bills of Mortality and actual enumerations of the people, though, without explaining in a satisfactory manner how he obtained his information, which, if it be correct, must have cost great labour. In his preface he says, "*il est tel page de ce livre qui a coûté nécessairement deux mois de travail, et un volume de chiffres.*"

The fourth edition of Dr Price's *Observations on Reversionary Payments* appeared in 1788, and contained much new and valuable information on these subjects, as has already been observed in the historical introduction to the article ANNUITIES in this *Supplement*.

In 1786 was published, at Petersburg, in the *Acts of the Academy of Sciences* there, for the year 1782, an essay by M. Krafft, on the marriages, births, and burials, at St Petersburg, during a period of 17 years, from 1764 to 1780, preceded by a general exposition of the uses such tables might be applied to, if the observations they record were extended over entire governments in Russia. This paper contains seventeen tables, which show the number of deaths at each age, and by each of the principal diseases, together with the numbers of marriages and baptisms; the numbers in each case, being given for each of the 17 years separately, as well as for the whole term; and the sexes are always distinguished; as are likewise foreigners from the native Russians.

Bills of Mortality.

Bills of Mortality.

These tables would have been rendered very valuable, had they been accompanied by statements of the numbers of the living of each sex in the different intervals of age; but for want of this information, it is difficult to apply them to any useful purpose, and many of the inferences M. Krafft has drawn from them are very uncertain.

Carlisle and its neighbourhood. M. Nicander was a Member of the Royal Academy of Sciences at Stockholm, also one of the Commissioners of the *Tabellvärket*, and their secretary. We are sorry to announce his death, which took place in the summer of 1815.

Dr Heysham.

During a period of nine years, commencing with 1779, and ending with 1787, Dr Heysham of Carlisle kept accurate registers of the births, and of the deaths at all ages, in the two parishes which comprehend that city and its environs; also the diseases or casualties which the deaths at each age were occasioned by; and the sexes were in all cases distinguished. These excellent registers were kept with great care and skill on the plan of Dr Haygarth above-mentioned, and included all dissenters within the two parishes. Dr Heysham published them from year to year as they were made, and accompanied them with valuable observations on the state of the weather and diseases in each year. Their value was greatly enhanced by two enumerations of the people within the two parishes, the one made in January 1780, the other in December 1787, in both of which the ages were distinguished, but not the sexes of each age, though the totals of each sex were. These documents, printed in convenient forms, with further information respecting them, and many useful tables deduced from them, may be found in Mr Milne's *Treatise on Annuities*.

In the year 1800 was published, at Paris, in M. Mourgue 8vo, under the title of *Essai de Statistique*, a memoir by J. A. Mourgue, on the births, marriages, and deaths, that took place in Montpellier during a period of 21 years, ending with 1792, with the ages at which the deaths happened, the sexes are also distinguished, and the population of the place appears to have been nearly stationary. The tables and observations of M. Mourgue appear to be more valuable than any others relative to the population of France, that have yet been published, except those of M. Deparcieux, which related only to select orders of the people. This memoir was read at a meeting of the French National Institute in 1795, and printed in the *Mém. des Sav. Etr. an. 14*.

Mr Barton;

In the third volume of the *Transactions of the American Philosophical Society*, published in 1798, were inserted *Observations on the probabilities of the duration of human life, and on the progress of population in the United States of America*, contained in a letter from Mr Barton, which had been read to the Society in March 1791; also a postscript to that letter, read in December following; the returns of an actual enumeration of the people in the United States having been made in the mean time. The information there given from the parish registers is of little value. In the enumerations, the sexes were distinguished, but not the ages, except the numbers of free white males under and above sixteen; but even that information with regard to the population of America is very interesting, whether we contrast the early with the more recently settled counties, or the whole of the United States with the population of Europe.

An enumeration of the people in Spain was made by royal authority in the years 1768 and 1769, and again in 1787; a minute account of this last was printed at Madrid, showing for each province separately, the numbers of parishes, cities, towns, villages, &c. &c. with the number of people in each class according to their ranks, professions, occupations, &c. and the monastic orders of both sexes were particularly distinguished: to these was prefixed a summary of the census of 1768 and 1769. In these two enumerations, the ages of the people were not distinguished with sufficient minuteness; they only showed how many were under 7, between 7 and 16, 16 and 25, 25 and 40, 40 and 50, and above 50. In both enumerations, together with the ages, the distinction of the sexes was given; in the first, the married were only distinguished from the single; but that of 1787 showed how many of each sex, and in each interval of age, were in the states of celibacy, marriage, and widowhood.

M. Nicander.

In the years 1799, 1800, and 1801, M. Nicander inserted eight different memoirs among those of the Royal Academy of Sciences at Stockholm, exhibiting the state of population and mortality in all Sweden and Finland, from the year 1772 to 1795 inclusive. These contain a great number of tables, which present the most interesting results of the *Tabellvärket* during that period; the ages and sexes, both of the living and the dead, are distinguished with sufficient minuteness, and the number of deaths of each sex by every disease is given. The information in these papers is much more complete and satisfactory than any other yet collected respecting the state of the population of a whole kingdom, or even of any particular part of it, if we except the observations of Dr Heysham, which were confined to

A third enumeration of the people in Spain and the Spanish possessions in Europe and Africa, including the Canary Islands, was made in 1797; and a full account of it, occupying nearly 50 large tables, was printed at Madrid in 1801. The distinction of the ages in this enumeration was still not sufficiently minute; under 40 it was the same as in the two preceding, but after that age, the number of the living in each interval of 10 years to 100 was given, and the number above 100.

No information from the parish registers in Spain was given in any of these cases; although satisfactory extracts from them all, distinguishing the ages and sexes of the deceased, or even from those only which could be most depended upon, during the ten years that intervened between the two last enumerations, would have rendered the results of these incomparably more valuable, provided that the population of the places for which correct registers were given, could be distinguished from the rest. Those to whom the superintendence of these measures were entrusted in Spain, seem to have been well aware of this, and to have actually entered upon the formation of these necessary supplements to the enumerations,

Bills of Mortality.

as appears by the following passage extracted from the introduction to the printed statement of the last census:—

“*Interin que se forman las tablas necrológicas, las de nacidos y casados, en que entiende el ministerio de Estado, y que son muy útiles para valuar casi geométricamente el total de la población del Reyno, debemos contentarnos con las noticias que nos proporcionen los censos executados por el método que el presente.*”

But the author of this article has not yet succeeded in his endeavours to procure further information as to these tables of births, deaths, and marriages.

Dr Heberden.

In 1801 were published (in 4to), *Observations on the Increase and Decrease of different Diseases, and particularly of the Plague*, by William Heberden junior, M.D. F.R.S. containing some tables, chiefly deduced from the London bills. In the advertisement prefixed to this valuable tract, we are informed that it had been intended to be subjoined to a new edition of the Bills of Mortality; which edition, however, was not published. We are also indebted to the same ingenious physician for other interesting observations on the mortality in London, inserted in the *Philosophical Transactions of the Royal Society* (for 1796), and in those of the *London College of Physicians*, Vol. IV.

Dr Willan.

In the same year (1801) was published (in 12mo) another valuable work, entitled, *Reports on the Diseases in London, particularly during the years 1796, 1797, 1798, 1799, and 1800*, by Robert Willan, M.D. F.A.S. part of which had been previously inserted in some periodical publications; the author's observations were made both on the Bills of Mortality, and on the cases that occurred in his own practice.

In reading the writings of the physicians who have treated these subjects, it is impossible not to regret, that they have been so little attended to by the medical profession in general, and that Bills of Mortality have not been more generally kept in such a way, as to throw the lights which they alone can, on the causes of the increase and decrease of different diseases, and of the great differences that are found between the degrees of mortality in different situations, and among different classes of the people. The information of this kind already before the public clearly shows, that the general causes which tend to shorten life do also embitter it; and that where the people are the most happy, useful, and respectable in their several stations, there also, *cæteris paribus*, they are the longest lived. And these inquiries, we think, are of more importance to governments, and better worth their attention, than statesmen are generally aware of.

In the sixth volume of the *American Philosophical Transactions*, published in 1809, two tables were given, showing the number that died of each disease in each interval of age, during the years 1807 and 1808 separately, in the city and liberties of Philadelphia, which were communicated by the Board of Health; the numbers both of adults and of children who died in each month of each of these two years, are also given; and it is modestly added, that any suggestions for further improvements will be thankfully received. We therefore beg to suggest, that

Bills of Mortality.

the distinction of the sexes, which has not been made, would be a material improvement; and it might also be useful to state, what year the Board consider to be the limit between childhood and adulthood. If, in addition to this, the number of the people in each interval of age within the city and liberties, be determined at regular intervals, as every 5th or 10th year, and the registers of deaths, with the diseases and ages, be regularly continued for several such periods, the annual births of each sex being also given, they cannot fail to become very valuable.

In pursuance of an act of Parliament (41st Geo. III. cap. 15.), an enumeration of the people in Great Britain was made in 1801: also returns of the baptisms and burials in England and Wales, during the year 1700, and every tenth year after that till 1780, then for every year to 1800 inclusive, with the number of marriages in each year from the commencement of 1754 to the end of 1800. Large and clear abstracts of the answers and returns to this act were printed by order of the House of Commons in 1802, and occupy more than 1000 pages folio. In 1811; another act (51st Geo. III. cap. 6.) was passed, “for taking an account of the population of Great Britain, and the increase or diminution thereof;” in consequence of which, returns were that year made to Parliament, of the number of persons in every part of Great Britain; also of the numbers of baptisms, burials, and marriages in England and Wales, during each of the preceding ten years; very satisfactory abstracts of these were also printed by order of Parliament, in 1812, with some preliminary observations, in which corrections of the preceding returns are given.

Observations on the British Population Acts.

The sexes were distinguished both in these enumerations and extracts from the registers, but the ages in none of them; and the proportions of males to females among the living are not to be depended upon, a number of males in the army and navy, which it is difficult to estimate, not being natives of Great Britain, nor usually resident there. The returns of baptisms and burials were also defective, but few registers of dissenters having been included in them.

These abstracts are, however, with respect to the objects they extend to, more minute and satisfactory, than any other accounts of the same kind that have been published; and it is very desirable that such returns should continue to be made, and abstracts of them printed at regular intervals; for nothing is so well calculated to show the influence of different causes on the prosperity of a nation, as the comparison of the different states of the population, and the rate of its progress or declension, under different circumstances: besides, the value of the abstracts we already have, will be much enhanced by the publication of others of a similar kind hereafter.

It is much to be regretted, that no information as to the ages of the living, or those at which the deaths took place, was required by either of the acts above referred to; nor any encouragement or facility afforded to those who might be disposed to collect such information; and, consequently, that none was given in the returns.

Without better regulations for the keeping of mortality registers than those at present in force, with-

Bills of Mortality.

out such as should extend to dissenters of every denomination, it would probably be better not to require returns of the ages of the deceased from all parts of the kingdom; for defective or inaccurate returns would only mislead, and, not to mention the difficulty and expense of procuring returns of the ages of all the living, they would be comparatively of little use, where those of the dead were wanting.

But if government were to print forms for making returns both of the numbers of the living and of the annual deaths in proper intervals of age, throughout the extent of life; only sending such forms along with those now in use, to such as should apply for them,—then, persons who take an interest in such inquiries, and have the means of making correct returns, might do so with advantage. And a summary of all of that kind made from different parts of the kingdom, would convey much important information. Returns also, from such places only as were similarly circumstanced, might be collected into as many summaries as there were material varieties in the circumstances; and thus would afford the means of determining the different modifications of the law of mortality, which different circumstances produce. If the diseases that occasioned the deaths were also inserted, the greater prevalence of particular diseases in some circumstances than in others, would be apparent, with their effects, and the probable means of preventing them, or lessening their mortality.

But, the population enumerated must always be precisely that which produces the deaths registered; the grand desideratum being, to determine the number of annual deaths at each age, which takes place among a given number of the living at the same age.

Mr Milne.

Mr Milne's *Treatise on Annuities and Assurances* was published in 1816, and contains clear abstracts of the most important statements of this kind that have been published since Dr Price's time; these will, we believe, be found to be much more valuable than any thing of the kind that was extant when that ingenious author wrote, whose work has been generally referred to for the best information on such subjects.

Observations on the Forms of Bills of Mortality.

Of all the statements derived from bills of mortality and enumerations of the people, which we have mentioned, only those for Sweden and Finland, and Dr Heysham's for Carlisle, have been given in the proper form, and with sufficient correctness to afford the information, which is the most important object of them all,—that which is necessary for determining the law of mortality.

To effect this, it is only necessary to know the mean number of the living and of the annual deaths, in sufficiently small intervals of age, throughout the extent of life, for a period of time sufficient to allow of the accidental fluctuations arising from more or less fruitful years, and other causes, compensating each other: such periods, probably, should not be less than eight or ten years; but the necessary length will depend upon the climate, the number of the people; their general modes of life, and their political circumstances.

These data being obtained, it is not difficult to determine the proportion of the annual deaths to the number of the living in each year of age. Then,

Bills of Mortality.

assuming any number of births, as 1000 or 10,000, it is easy to show how many would die in each year of their age; and, consequently, how many would survive that year; which numbers of survivors and of annual deaths, when arranged in the order of the ages, constitute the desired table of mortality, by which all the most important questions respecting the duration of human life may be easily resolved.

For want of understanding the principles upon which the proper construction of such tables depends, most of the writers on this subject, many of them men of great merit and industry, have taken much pains to little purpose, and after excessive labour, have arrived at false conclusions. Hardly any of them appear to have been aware of the necessity of obtaining the number of the living, as well as of the annual deaths in each interval of age, or that that would greatly enhance the value of Bills of Mortality, by extending their useful applications.

Dr Price's *Essay on the proper Method of constructing Tables of Mortality*, already twice mentioned in this article, was intended to show how such tables might be constructed from registers of the deaths only at all ages; but the hypotheses he proceeded upon can hardly obtain in any real case; and even if they did, his method would only determine the number of the living in the place, at every age; therefore, if it could be put in practice (which it never can), it would only supersede the necessity of actual enumerations; and, with the numbers so obtained, we should have to proceed as above.

That *Essay* of Dr Price was an amplification of what Mr Simpson had previously advanced on the subject, with his accustomed accuracy, and contains many just observations on the defects of the tables of mortality that had previously been published; but so far as it contributed to induce a belief that the determination of the number of the living in every interval of age, by actual enumeration, was not necessary to the construction of accurate tables, it must have done harm. What is here stated will be found demonstrated in the third chapter of Mr Milne's *Treatise on Annuities*.

We come now to the

FORMS SUBMITTED

FOR BILLS OF MORTALITY AND FECUNDITY.

It is desirable that a bill should be published for each year separately, to show how the rates, both of mortality and fecundity, vary with the circumstances of the people in different years; and, from these yearly bills, nothing is more easy than to derive others for longer periods.

According to the form A, the births of both sexes in each year will be distinguished, and the born alive from the still-born; the number of marriages will also be given.

In this, and all other cases where those who undertake the formation of such bills are either unable or unwilling to distinguish all the particulars indicated, the reasons for the omissions should be inserted in the spaces set apart for the numbers omitted. But,

BILLS OF MORTALITY:

Bills of Mortality.

where the still-born are not distinguished as such, they should be omitted entirely, and the number of births stated should be that of the children born alive.

The numbers of deaths of the two sexes in each interval of age, during any year, may, as they are collected from the registers, be conveniently disposed according to the form B; the intervals between 5 years of age and 100, being each 5 years; and the number dying at each age above 100 should be particularly specified. It would, indeed, be much better to give a separate statement of the number of each sex dying in each year of age above 90; for the whole number is never very great, and any error committed at the greater ages, in constructing a table of mortality, affects all the preceding numbers in the table.

But some persons, who would not take the trouble of forming bills of mortality in which the ages are to be so minutely distinguished, might yet be willing to furnish them with the requisite care, according to the form b, which might still be very useful; and, indeed, from 20 to 60 years of age, intervals of 10 years each might do very well.

The value of Bills of Mortality would be greatly enhanced, by inserting in them the contemporaneous wages of labourers in agriculture, and of the workmen employed in the more common kinds of trade and manufacture carried on among the people they relate to; also the prices of the necessaries of life which persons of these descriptions consume the most of; together with any thing uncommon in the seasons or the crops, and every material change in the circumstances of the people.

ENUMERATIONS.

The number of the people in the several intervals of age, which we have stated above to be of so much importance, may be disposed in tables exactly similar to B or b, recommended for the deaths; but it is not necessary that the duration of life should be divided into the same intervals for the living as the dead. It is always desirable that the intervals should, in both cases, be small; but yet not so small, as, by the increase of labour, to occasion the numbers being determined with less exactness, or to deter many from engaging in the work. Such intervals should not, however, exceed ten years.

When the bills are given for a certain period, if there be but one enumeration of the people, it should be made at the middle of the period; if two, at its extremities; and if more than two, it is desirable that they should be made at equal intervals of time throughout the period.

We give no forms here of Bills of Mortality and Fecundity, designed to distinguish legitimate from illegitimate children, or the mortality or fecundity of each month of the year, nor the number of women delivered annually at the different periods of life, nor the diseases the deaths were occasioned by. Neither are the forms here recommended for enumerations

of the people, calculated to distinguish the numbers in the different states of childhood, celibacy, marriage, or widowhood; nor the ranks, or professions, or occupations of the people. All these things are curious, and of some use, although, if we except the diseases which the deaths of each sex at the different ages were occasioned by, they are of little value in comparison with the information the forms here given are calculated to convey. And it is of so much importance that that information should be given correctly, that we would willingly forego these minor objects, to avoid dividing and fatiguing the attention of those who undertake the more important part of the task, which is of itself sufficiently laborious.

And those who may be disposed to keep registers, and form bills and enumerations, on a scale so much extended as to include all these particulars, or most of them, and have also the requisite qualifications, will find no great difficulty in preparing the most convenient forms of tables for the purpose. Several forms of that description, with references to others, will be found in Mr Milne's *Treatise on Annuities*

Bills of Mortality.

A.

During the year 18 .	Males.	Females.	Both.
Born alive, - -	449	431	880
Still-born, - -	13	9	22
Whole number born,	462	440	902
Number of Marriages, 261.			

B.

	Between the							Ages of			Totals.
	0 & 1	1 & 3	3 & 5	5 & 10	10 & 15	15 & 20	20 & 25	90 & 95	95 & 100	above 100	
Males	210	152						7	4	0	881
Fem.	180	149						18	10	2	959
Both	390	301						25	14	2	1840

b.

	Between the Ages of											Totals.		
	0 & 5	5 & 10	10 & 20	20 & 30	30 & 40	40 & 50	50 & 60	60 & 70	70 & 80	80 & 90	90 & 95		95 & 100	above 100
Males	417	42									7	4	0	881
Fem.	395	47									18	10	2	959
Both	812	89									25	14	2	1840

See MORTALITY, LAW OF, in this Supplement. (v.)

Black Sea. BLACK SEA, or *Euxine Sea*, *Pontus Euxinus* of the ancients, is a large inland sea, bounded on the west by Roumelia, Bulgaria, and Bossarabia; on the north by Russian Tartary; on the east by Mingrelia, Circassia, and Georgia; and on the south by Anatolia. It is entered from the Mediterranean through the channel of the Dardanelles, the ancient *Hellespont*, the Sea of Marmora, *Propontis*, and the channel of Constantinople, *Thracian Bosphorus*; and it is connected with the Sea of Azoph, *Palus Mæotis*, by the strait between the Crimea and the isle of Taman, the ancient *Cimmerian Bosphorus*, known by the various modern names of the Strait of Caffa, of Yenikale, and of Taman.

Progressive Geography. Till within the last thirty years, the extent of the Black Sea, and the position of several of its principal capes, gulfs, and ports, were very imperfectly ascertained. Soon after the commencement of the French Revolution, the National Institute sent M. Beauchamp to examine this sea, and especially its southern shores. In this enterprise he was much impeded by the jealousy of the Turks; nevertheless, he ascertained that Cape Kerempe, *Carambis*, was placed in the charts too far to the south; that the Gulf of Sansoun, *Amisenus Sinus*, was deeper than represented; and that Tribizonde, Tarabagan of the Turks, *Trapezus*, was five or six leagues further to the west than it appeared in the charts. Recent travellers have discovered that even the Parisian charts are inaccurate. According to Dr Clarke, the Isle of Serpents, Ulan-Adassi of the Turks, Fidonisi of the modern Greeks, the ancient *Leuce*, lies 15 minutes, and the port of Odessa 27 minutes, too far towards the north (Clarke's *Travels*, I. 653); and Mr Macgill ascertained, from two very good observations of his own, compared with those of some captains who had navigated this sea, that, in the French charts, even Cape Kerempe is not accurately placed, it being set down 15 miles too far north, while Cape Aria, or Careza, *Criu-Metopon*, in the Crimea, is placed 22 miles too far south. This, of course, makes a difference in the width of the sea at this place of 27 miles (Macgill's *Travels*, I. 195).

Extent. According to the best authorities, which Mr Arrowsmith has followed in his maps of this sea, it lies between 41 and 46½ degrees of north latitude, the bottom of the bay of Sansoun penetrating nearly to the 40th degree, and Cape Kerempe stretching out nearly to the 42d; and between 28 and 41½ degrees of east longitude from Greenwich. This will give for its breadth, from Cape Baba in Anatolia to Odessa, about 380 miles; and for its length, from the coast of Roumelia to the mouth of the Phasis, 932 miles. The Black Sea, however, may be considered as divided into two parts, by Cape Aria on the south of the Crimea, and Cape Kerempe on the coast of Paphlagonia, the former lying in about 44½, and the latter in about 42 degrees of latitude. Both these capes being high land, vessels sailing between them can discover the coast on either side. The circumference of the Black Sea is about 3800 miles.

Name. It derives its modern name either from the dense fogs which frequently cover it, or from the dangers of its navigation arising from these fogs; the sudden

and violent storms to which it is exposed; and the shallows hitherto unnoticed in any chart. The origin of its ancient name is given in the *Encyclopædia*, under the article *EUXINE*.

The opinion of the ancients, that the Black Sea was formerly much more extensive than it is at present, and that it did not originally communicate with the Mediterranean, is embraced by many modern authors of note, particularly Tournefort, Buffon, Pallas, and Dr Clarke, and seems to be confirmed by several circumstances. Immense strata of limestone, consisting almost entirely of mineralized sea-shells, may be traced the whole way from the Black Sea towards the north, as far as the 48th degree of latitude; and Pallas, in the third and seventh volumes of his *Travels*, has pointed out traces of its former extent over all the desert of Astracan and Jaik. The evidences derived from the appearance of the present coast of this sea, are still less equivocal in support of the diminution of its waters. Pliny expressly states, that *Taurica*, the Crimea, was not only once surrounded by the sea, but that the sea covered all the champaign part of it. Now, there are layers of marine shells all the way from the mouths of the Dnieper to those of the Don; and if we suppose the waters of the Black Sea to be restored only to the level of these layers, the Crimea will appear again an island. The alluvial nature of more than three-fourths of the soil of Crimea Proper to the north, the numerous salt lakes and marshes, and the remains of marine productions of various kinds which are found there, sufficiently confirm the latter part of Pliny's statement.

The ancients believed that the communication between the Black Sea and the Mediterranean, and the consequent diminution of the waters of the former, was effected by the bursting of the Thracian Bosphorus, at the period of the deluge which inundated Greece; and this tradition is confirmed by a reference to existing natural phenomena. The cliffs and hills at the mouth of the Bosphorus, are composed of enormous pebbles, which appear to have undergone the action of fire, and afterwards to have been rounded by long contact in water. On the points of the European light-house, there are immense rocks of hard and compact lava; and the rock of which the Cyanean Isles consist, appears to have been more or less modified by fire, and to have been cemented during the boiling of a volcano. On the Asiatic side of the strait, a little to the east of the Anatolian light-house, there is a range of basaltic pillars, exhibiting very regular prismatic forms. From the consideration of all these observations, and comparing events recorded in history with the phenomena of nature, Dr Clarke considers it more than a conjectural position, "that the bursting of the Thracian Bosphorus, the deluge mentioned by Diodorus Siculus, and the draining of the waters, which once united the Black Sea to the Caspian, and covered the great oriental plain of Tartary, were all the consequence of earthquakes caused by subterranean fires, described as still burning at the time of the passage of the Argonauts, and whose effects are visible even at this hour." (I. 680.) It is proper to mention,

Black Sea. that Olivier does not coincide with other naturalists respecting the former extent of the Black Sea, or the bursting of the Thracian Bosphorus.

Changes in its Coasts. The north and west coasts of this sea have undergone, and are still undergoing, considerable changes: the southern coast, consisting chiefly of calcareous rocks, is nearly in the same state in which it was in the time of the ancients. According to Valerius Flaccus, the gulfs and bays in the north and west coasts were extremely deep; most of these are now all either entirely filled up, or much contracted. In proof that the Black Sea and the Sea of Azoph are still sustaining a diminution of their waters, it may be stated, that ships which formerly sailed to Taganrock and the mouths of the Don, are now unable to approach either the one or the other; that the Sea of Azoph has become so shallow, that, during certain winds, a passage may be effected by land from Taganrock to Azoph, through the bed of the sea; and that the isthmus connecting the Cyanean Isles with the Continent, which does not appear to have existed in the time of Strabo, appears to be increasing. On the southern coast of the Black Sea, there is, as far as we know, only one instance of a recession of the waters: the channel which formerly divided the village of Amasrah, *Amastris*, is now filled up, and forms a low isthmus.

Currents. A rapid current, which generally flows at the rate of a league an hour, the influence of which is felt at the distance of ten miles from land, when it begins to take another direction, sets from the Black Sea into the Bosphorus. Sometimes, however, the long continuance of a strong south-west wind effectually counteracts this current. The Black Sea, from its particular form, being like a basin, into which many large rivers pour their streams, is full of currents, particularly in summer, when the rivers are increased by the melting of the snows: when strong winds act against these currents, a high sea is produced. North-east winds prevail from June to August inclusive; the most prevalent winds, at other seasons of the year, are from the south and south-west. The general climate of the Black Sea is cold and humid; the winters are long and frequently very severe, but the navigation is free of impediment from ice till the beginning of November, and often much later. The quantity of fresh water conveyed into this sea renders it brackish, and liable to freeze with a moderate degree of cold. It is calculated by some authors, particularly Tournefort (II. 404), and the Abbé Barthelemy (*Voyage d'Anacharse*, Tom. I. c. 1), that what it receives is much more than what it discharges into the Mediterranean. Dr Clarke, however, is of opinion, that the rivers which fall into the Black Sea and the Sea of Azoph, do not communicate more water than flows through the canal of Constantinople; hence he concludes, that, admitting the effect of evaporation, the level of the Black Sea insensibly falls (I. 628).

Rivers. The Black Sea receives a considerable portion of the fresh waters of Europe, as well as of Asia Minor. The Danube collects the waters of a great part of Germany, Hungary, Bosnia, Servia, &c. The Dniester, Bog, Don, and Dnieper, discharge

into it those of a part of Russia and Poland. The Black Sea. Phasis collects those of Mingrelia; and the San-garis, and Kisil Irmak, *Halys*, part of those of Anatolia.

In the Black Sea are found the tunny fish, which enters it to spawn; sturgeon, sterlet, porpoise, mac-karel, soal, turbot, whiting, &c. It abounds with a species of sea-worm, four or five inches long; its head is like an arrow, and its body consists of a whitish mucilage: these worms are very destructive to ships.

We shall begin our survey of the coasts and ports of this sea, at its entrance from the Bosphorus, and proceed along its western shores. Off each point of the entrance of the Bosphorus from the Black Sea is a group of rocky islets, which retain their ancient name, Cyanean Islands. These have been already described. From the Bosphorus to Kara-Kerman, which lies within a few miles of the southernmost branch of the Danube, the coast is lined by the mountainous ridge of Balkan, *Hæmus*, which terminates at Cape Emeniah, *Hæmi extrema*. The valleys between these mountains form little coves, where vessels are laden with the timber of *Hæmus* for Constantinople. The forest of Belgrad, which takes its name from a village near Constantinople, extends along the south-west corner of the Black Sea, for about 100 miles. Incada, *Thenias*, lies on this coast in 41° 52' north latitude. On the north side of the harbour there is good anchorage; it is only exposed to winds from the east and south-east, and is sufficiently spacious to contain a fleet; a heavy sea, however, enters it, when those winds blow to which it is exposed: Its chief export is charcoal to Constantinople. At the head of the Gulf of Foros, which is bounded on the south by Cape Emeniah, is four or five leagues wide, and runs into the land nearly the same distance, is Burgos, which exports a considerable quantity of wool, iron, corn, butter, cheese, &c. to Constantinople. There are several roads in this gulf fit for the largest ships.

On the coast of Bulgaria is Varna, at the mouth of a river, which forms a large lake and extensive marshes; hence provisions are sent to Constantinople. Kara-Kerman, *Istropolis*, is a large village on the beach; several shoals lie off it, which oblige vessels to anchor a league to the south. Its principal export is corn.

From Kara-Kerman to Actiar, in the Crimea, the coast is very low, and the shoals formed by the rivers run off a considerable distance. The Danube empties itself into the Black Sea, between Bulgaria and Bossarabia, by seven mouths, among swampy islands and shifting banks. The most frequented mouth is 100 fathoms wide and 3 fathoms deep; its stream runs out at the rate of three miles an hour. So great is the extent over which the waters of this river diffuse themselves, from the shallowness of the sea, that at the distance of three leagues from its mouth the water is almost sweet, and within one league it is perfectly fit for use. A very singular appearance takes place in the mouths of the Danube;—the porpoise, which every where else exhibits a dark colour, is there perfectly white; hence, as soon as the Greek mariners descry the white por-

Black Sea. poise, they have no doubt that they are in the current of the Danube, although in 30 fathoms water, and many leagues distant from its mouth. Opposite the mouths of this river is Serpents Island, already noticed. Kilia-nova, belonging to Austria, is a port of small consequence, at one of the mouths; it might, however, be rendered highly important, by vending the productions of Hungary, if the navigation of the river were not obstructed by the jealousy of the Turks.

Serpents Island.

Coasts and Ports of Cherson.

Odessa.

The Russian province of Cherson is divided from Bessarabia by the Dniester Tyras. A bank before it forms two channels; that on the west, called the channel of Constantinople, is 150 fathoms broad; and that on the east, called the channel of Ockzakoff, 80; neither have more than eight feet water. Akerman, on the south bank of this river, has some export trade in corn, wool, wine, wood, hides, and butter. Between the Dniester and Dnieper stands Odessa, the most flourishing port in the Black Sea. It owes its prosperity, not so much to any natural advantages, as to the wise administration of the Duke of Richelieu, while he was governor of this province. It is situate close to the coast, which is here very lofty, and much exposed to the winds, especially to the east. In order to render it a safe and commodious port, the Duke caused a harbour to be formed, in which ships of no small burden may ride secure from every storm. He also built a large mole, extending half a werst into the sea; several smaller ones, and a handsome quay, one werst and a half long. The roads without the port are safe in summer, and the anchorage good. Odessa labours under the want of a navigable river, and a great scarcity of fresh water. In the year 1805, 595 vessels were entered at this port, of which 27 were under the English flag; 264 were Austrians, owned by the merchants of Trieste, but employed as the carriers of Spain and Portugal. In the year 1816, up to the 28th of June, 498 ships had entered Odessa, bringing merchandize to the value of one and a half million of rubles, besides a very large quantity of specie. During the same period, there sailed 246 ships laden with Russian produce, to the amount of 15,220,000 rubles, including above 324,000 quarters of wheat. The principal imports are wine, chiefly French, some rum, raw silk, coffee, sugar, oil, soap, sulphur, fruit, linen cloth, &c. but all in very limited quantities. The great article of export is wheat, which, however, in the opinion of Mr Macgill, is very far inferior to that of Taganrock, being soft, and apt to heat; besides this, grain, rye, barley, oats, tallow, and tallow candles, beeswax, iron, hemp, &c. are exported.

The Dnieper.

The Bog.

Ockzakoff.

The Dnieper, *Borysthene*s, which separates the Russian provinces of Cherson and Taurida, forms, near its mouth, a shallow and marshy lake, two and a half miles broad, a-breast of Ockzakoff, but more at the confluence of the Bog. The entrance is almost closed by shifting sand banks, between which, there is seldom more than five feet water. The Bog, *Hypanis*, falls into the gulf of Leman, or estuary of the Dnieper. There is a very small island opposite the mouth of the latter river, almost inaccessible on account of its perpendicular cliffs of rock and clay. Ockzakoff is a small port, lying at the junction of

these rivers; its harbour is perfectly secure, but the little trade it formerly possessed, has been drawn away to Odessa. Opposite to Ockzakoff is Kinburn, which, before the building of Cherson, was intended by the Russians as the principal depôt for the merchandize sent from the provinces bordering on the Dnieper. The extension of the Russian dominions on the west, has caused even Cherson, on the right bank of the Dnieper, to be superseded by Odessa. Yet corn, hemp, and other articles of exportation, are so much cheaper, and more plentiful here, that many foreign vessels still prefer this port, though they are obliged first to perform quarantine, and unload their cargoes at Odessa. The Dnieper is five miles wide at Cherson, but only vessels that draw six feet can ascend to it. The Russians, however, have a large arsenal here, and build line-of-battle ships, which are floated down the river on machines, and afterwards conveyed to Ockzakoff to be equipped. Nicolae, on the Bog, a fine river, without bar or cataract, with deep, still water, is the station for vessels when built, and here they are laid up to be repaired. It has extensive marine arsenals, being the seat of the Russian marine administration on the Black Sea.

Black Sea.

Cherson.

South Coast of the Crimea.

The southern coast of the Crimea is lofty and precipitous; the mountains beginning at Balaclara, *Symboli*, and extending to Caffa, *Theodosia*. Some of these are celebrated in antiquity, and are no less remarkable for their formation and appearance. The mountain Tchedirdagh, *Trapezus*, rises rapidly from the coast about Alusta to the height of 1200 or 1300 feet; it exhibits a mass of limestone very compact, of a grey colour, and according to Pallas, upon friction, slightly foetid. The remarkable headlands of the Crimea are Cape Tarchanokoi, called by the Tartars Aya-Burun, or the Sacred Promontory, probably the *Parthenium* of Strabo; one of the loftiest mountains in the Crimea, terminating abruptly in the sea, and forming the west point of the Peninsula. It consists of marble. On the south point is Cape Aria, *Criu-Metopon*, formerly noticed.

The first port of note on the west coast of the Crimea is Kosloff, or Eupatoria, from which, in 1793, 176 vessels were freighted with corn, salt, and leather; but at present, its commerce is nearly annihilated. Sevastopol, formerly Actiar, *Ctenus*, is the chief station of the Russian Black Sea fleet, no merchant ship being allowed to enter it, except in distress. The natural advantages of this harbour are very great. The largest vessels lie within a cable's length of the shore. The harbour is divided into three coves, something resembling that of Malta. The principal branch runs east, and is terminated by the valley and little river of Inkerman. Here the fleets of the world might ride secure, and have convenient anchorage; and in any of the ports, vessels find from 21 to 70 feet depth of water, and good anchorage. On a tongue of high land between the two southern creeks stands the Admiralty and storehouses. The great bay of Actiar also bears the name of the Roads, and here the Russian fleet is frequently at anchor. The port of Balaclara is separated from that of Actiar by a narrow peninsula. It

West Coast of the Crimea.

Balaclara

Black Sea. is one of the most remarkable in the Crimea, appearing from the town landlocked by high precipitous mountains. Its entrance is so extremely narrow, that only one ship can pass at a time; but within the port, it is three quarters of a mile long, and 400 yards broad; it is secure in all weather from storms; and ships of war of any burden may find in it sufficient depth of water. The mountains which surround it are of red and white marble, and the shore in some parts is covered with gold coloured mica, in a state of extreme division. This port is closed against the vessels of all nations, not excepting Prussians, to prevent smuggling. Caffa lies on a bay, capable of containing several hundred merchant vessels, but exposed to the east and south-west. It formerly carried on the most extensive trade in the Black Sea; but it is now of very little consequence. Kertchi, *Ponticapium*, on a peninsula, *Chersonesus Cimmerica*, stretching into the strait of Taman, and Yenikale, at the extremity of the same peninsula, are small ports chiefly inhabited by fishermen.

Caffa.

Coast of
Anatolia.

The coast of Anatolia, on the Black Sea, extends to the Kesil-Irmak, which falls into this sea a little to the west of the Gulf of Sansoun. It is lined by high mountains, terminating in lofty promontories. It is steep and clean, with numerous little coves, into most of which small rivulets fall. The most remarkable headlands are Cape Kili-Mili, east of Erekli; Cape Kerenipe, the north point of Asia Minor, very high land, with breakers off it; and Cape Indjee, a low point to the west of Sinope. The principal rivers on this coast, besides the Kisil-Irmak, *Halays*, and the *Sakaria*, *Sangarius*, already noticed, are the *Falios*, *Bettaus*, and the *Barthin*, *Parthenius*. The only port of consequence is Sinope, strongly situated on the narrow and low isthmus of a rocky peninsula. The mole which formed its port is nearly in ruins. The depth of water is 12 feet. There is, however, a good road for the largest ships; and Turkish vessels of war are built here. Sinope is the nearest port on the Black Sea to Angora, the only place hitherto known that supplies the fine goats' hair.

Coast of
Roum;

The coast from the Kisil-Irmak to Vona is named Roum by the Turks. The chief places are Sansoun, *Amisus*, on the Jekyl Irmak, which falls into the deep Gulf of Sansoun. *Fatsa*, *Polemonium*, at the mouth of the *Sidemus*, *Budjiah* and *Vona*, *Boona*, on the Cape of the same name.

of the La-
ziens.

From Vona, the coast takes the name of the tribes that inhabit it. The *Laziens*, *Lazi*, occupy the coast from Vona to the *Batouni*. The principal port on this coast is *Trebizond*. Though it can receive only small vessels, it has a considerable trade. One hundred and fifty or two hundred small craft annually sail to *Taganrock*, with *nardak*, a marmalade of grapes, and *beckmiss*, a syrup made for the use of the distilleries there.

Coast of the
Gurions.

Next to the *Laziens*, the *Gurions* occupy the coast, as far as the *Rioni*, *Phasis*. At its mouth this river is 60 fathoms deep, and half a league broad, but a small island lies in the midst of its channel. The only port in the country of the *Gurions* is *Poti*, to which the merchants of Georgia re-

sort; the *Mingrelians* occupying the country of the ancient *Colchi*. In this tract there is no port of consequence. The *Abasses* occupy the coast from *Isgarur* to the Strait of *Yenikale*, as far as *Anaffa*. This coast is very elevated, the *Caucasian* mountains approaching close to the sea. Near *Sondjuk* is a very lofty promontory called *Varda*. From *Anaffa* to the Straits, the coast is low. Some small vessels are built at *Anaffa* by the Turks. The *Kuban*, *Hypanis*, receives most of the waters of the western side of *Caucasus*. Near its mouth it divides into two branches, one of which falls into the Sea of *Azoph*, and the other into the *Black Sea*. The marshy isle of *Taman* is formed by it. On this island is *Fana Jona*, a place of some trade.

Coast of
Mingrelia.

The Kuban.

The commerce of the Black Sea, in ancient times, was successively in the possession of the *Phœnicians*, *Egyptians*, *Greeks*, and *Romans*. From the last it passed to the *Greeks* of the *Lower Empire*; from them to the *Venetians* and the *Genoese*. *Caffa* was the principal city of the commerce of the *Genoese* with the east; and the port at which was deposited all the merchandize which had been transported to the *Black Sea*. By the capture of *Constantinople* in 1453, this commerce was nearly destroyed; and by the capture of *Caffa*, in 1476, it was completely annihilated. One of the favourite objects of *Peter the Great* was to obtain a share in the commerce of this sea, which the subjects of the *Porte* alone were permitted to navigate. In 1699, he succeeded in subduing *Azoph* and the country round it; but, by the unfortunate battle of *Pruth*, in 1711, he was compelled to relinquish his conquests. His successors, and especially *Catherine II.* aimed at the same object. This enterprising sovereign, by the treaty of *Kainardgy*, in 1774, and afterwards by the treaty of *Jassy*, in 1791, completely accomplished her object; the *Turks* being obliged to surrender a part of *Lesser Tartary* and the *Crimea*, to allow the *Russians* to establish a navy in the *Black Sea*, and to permit their flag a free passage through the *Dardanelles*. In 1784, the *Porte* granted the privilege of navigating the *Black Sea* to the *Court of Vienna*. No other European nation obtained this privilege, though the *French* carried on a considerable trade under the *Russian* and *Imperial* flags, till after the conquest of *Egypt* by the *French*, when a treaty was concluded between the *French* government and the *Porte*, by which the latter granted the free navigation of this *Sea*. At the peace of *Amiens*, the navigation was opened to the *Prussian*, *Spanish*, *Neapolitan*, *Dutch*, *Ragusan*, and *English* merchant flags; and all these nations were allowed to have resident *Consuls* in the *Turkish* ports of this *Sea*. The *English*, however, by secret treaties with the *Turks*, in the reign of *James I.* and *Charles*, were granted the navigation of this *Sea*; and, in 1799, it was again granted.

History of
the Com-
merce of
the Black
Sea.

Soon after the peace of *Amiens*, the commerce of this *Sea* increased considerably: so that, in 1808, 815 vessels entered the *Russian* ports from the *Mediterranean*. Most of them came in ballast, and returned with corn. Of these 815 vessels, there were,

Black Sea.	Flags.	Loaded at.	Destination.
421	Austrians	552 Odessa	186 Trieste
329	Russians	210 Taganrock	144 Messina
18	Ragusans	23 Caffa	103 Caphalonia
16	Ionian Islands	19 Kosloff	72 Genoa
15	French	7 Serastopil	57 Leghorn
7	English	4 Cherson	26 Corfu
6	Hydriots	—	24 Barcelona
3	Spaniards	815	19 Marseilles
—	—	—	10 Naples
815	—	—	8 Malta
—	—	—	7 Tchasmé
—	—	—	4 Zante
—	—	—	155 sailed with-
—	—	—	out de-
—	—	—	815 claring
—	—	—	their des-
—	—	—	tination,
—	—	—	on ac-
—	—	—	count of
—	—	—	the war.

From these 815, the 210 which loaded at Taganrock ought to be deducted, in order to give an accurate view of the commerce of the Black Sea at this period.

The Russian exports from and imports to this Sea were, in

	Exports.	Imports.
1802	3,000,000 rubles	2,055,000
1804	5,000,000	4,200,000
1805	7,400,000	5,356,000

In the year 1802, 36 vessels, and 266 small craft, were employed by Russia, in the coasting trade of this Sea. There is also a considerable trade between the Russian ports and Constantinople and Smyrna, carried on entirely by Greek vessels under Russian colours.

In 1807, the Russian Black Sea fleet consisted of 12 sail of the line, 4 frigates, 7 brigs and cutters, and 18 small craft; and the Black Sea flotilla consisted of 40 gunboats and 80 falconets.

The principal articles of commerce afforded by the countries on the Black Sea, are wheat, rice, tobacco, hides, tallow, iron, hare-skins, honey, wax, and yellow grains for dyeing, from Roumelia and Bulgaria, by the ports of Varna and Burgos. The same articles, with the addition of wool, butter, hemp, masts, ship-timber, and pitch, from Moldavia and Wallachia, by Rudjuk and Galatz on the Danube. From Bessarabia, by Ovidopel, and from the province of Cherson, by Odessa, Akerman, and Cherson, corn, oak-timber, hides, tallow, tar, shagreen, wax, honey, hemp, sail-cloth, and wool. From the Crimea, by the ports of Actiar, Kosloff, and Caffa, corn, wool, wax, honey, dried and salted hides, deer-skins, morocco-leather; sheep-skins, salted and dried fish, potash, felt, caviar, wine, silk, and saltpetre. From Anatolia, by the ports of Erekli, Amasrah, and Sinope, hides, dried fruits, linens, linen-thread, wax, honey, hemp, copper, and ship-timber. From the countries of the Lazians and Gurions, princi-

pally by Trebizond, all the above articles, except ship-timber. From Mingrelia, and the country of the Abasses, principally by Sudjuk and Anaffa, slaves, timber, box-wood, wool, silk, furs, butter, hides, wax, honey, &c. The trade to these coasts is entirely carried on by a few Greeks of Constantinople, and is very insignificant.

See *Essai sur le Commerce, &c. de la Mer Noire*, Paris, 1805; *Oddy's European Commerce*, p. 169; *Clarke's Travels*, Vol. I. 4to edition; *Macgill's Travels in Turkey, &c.* Vol. I.; *Coxe's Travels*, Vol. III. 8vo edition; *Tuckey's Maritime Statistics*, Vol. II.

BLASTING, is a term used by the Engineer and Miner, to denote the application of the explosive force of gunpowder, in opening or rending rocks, indurated clay, consolidated earth, and the walls of old buildings. In quarrying sandstone, consisting of regular layers, the work is performed chiefly by means of the *pick*, the *wedge*, the *hammer*, and the *pinch* or *lever*; recourse being seldom had to the more violent and irregular effects of gunpowder. But for many kinds of limestone, and for greenstone and basalt, blasting is always resorted to; and some of the rocks called *primitive*, such as *granite*, *gneiss*, and *sienite*, could scarcely be torn asunder by any other means.

At what period blasting with gunpowder was first resorted to as a *power in mechanics*, is uncertain. Gunpowder was applied to military engines in 1330, but there is reason to believe that its application to the peaceful arts is of a much later date. It may seem strange at this day to propose the *expansive or explosive force* of gunpowder as a new *mechanical power*; but when the lever and the wedge become ineffectual to the purposes of the artificer, he must naturally attach a high value, and be disposed to give an elevated term, to that instrument or means by which he is enabled, in a very simple manner, to effect his purpose, and overcome the greatest obstructions to his operations. One could almost, therefore, wish it dignified with such a title as the **EXPLOSIVE POWER**.

This agent is no less simple in its application, than it is powerful in its effects. It is considered as the result of the sudden extrication of a *permanently elastic fluid* by the ignition of the gunpowder, the extricated gas occupying perhaps 1000 times more space than the grains of the powder. Some authors are of opinion, that the powder contains only atmospheric air in a state of great condensation, and that, when this fluid is set at liberty, being at the same time highly rarified by the heat, from the inflammation of the powder, it produces the wonderful effects already mentioned. By others, it is supposed that the air contained in the nitre of the gunpowder is about 244 times denser than atmospheric air, and that, when exploded, it produces an effect proportioned to its condensation; the elastic fluid expanding with a velocity which has been calculated at the rate of about 10,000 feet *per second*; and its pressure or force, when thus expanding, having been estimated as equal to a *thousand atmospheres*, or as a

Black Sea
Blasting.

Russian
Fleet.

Principal
Articles of
Commerce.

Blasting. thousand times greater than the atmospheric pressure upon a base of the same extent. If we apply this product to the pressure of the atmosphere, or at the rate of $14\frac{1}{2}$ pounds to the square inch, we shall find that the elastic fluid of gunpowder, at the moment of explosion, exerts a force equivalent to $6\frac{1}{2}$ tons upon the square inch of surface exposed to its force; and that with a velocity which even the imagination can hardly follow. Count Rumford, indeed, estimated this force at 10,000 atmospheres; but we have rather followed the calculations of Hutton, whose opportunities of experiment, connected with the Military College of Woolwich, have been unquestionably great.

The progress of quarrying and blasting rocks has, of late years, made great advancement in this country. In Europe, the art of mining was long chiefly confined to Sweden and Germany; but, since the disappearance of our thickly wooded forests, and the universal introduction of pit-coal for fuel, and of cast-iron in the arts, Britain has made rapid strides to improvement in the art of Mining, and now rivals her Continental neighbours. Here we may allude to the Coalworks of Northumberland and Durham, of Cumberland and the western counties of England and Wales. We may also notice the great extent of the like works in the south-eastern and south-western districts of Scotland. Much of this kind of work is done with the pick and shovel; but without the aid of the expansive force of gunpowder, these operations must have been of a very limited extent. Other works, of no less magnitude than those of Coal Mines, have been executed in Great Britain, almost wholly by the force of gunpowder, particularly in Canal and Road-works. To illustrate more fully the use of gunpowder in mining operations, we may mention the extensive works in Tunnelling, for preserving the level of canals through mountainous districts of country, instead of forming Locks, or following a circuitous line of navigation. The bold attempt of blasting rocks, under such circumstances, was, in this country, reserved for Mr Brindley, Engineer upon the Duke of Bridgewater's canals. In 1776, this celebrated Engineer completed the first navigable tunnel, at Harecastle in Staffordshire, which is upwards of one mile in length. Since that period, many other works of a similar nature, and even of much greater extent, have been executed in various parts of Europe. By the art of blasting, immense excavations have been made upon the Great Canal in Sweden. In France, a tunnel of about seven miles in length has lately been made; and, in our own country, at Sapperton, on the canal joining the rivers Severn and Thames, and at Marsdenhill, there is a tunnel, upwards of three miles in length, forced entirely through rock, by the use of gunpowder. We may also instance the great national work of the Caledonian Canal. In all of these works, in road-making, and many others intimately connected with the prosperity of commerce, the extension of the arts, our domestic comfort, and national importance, it is most evident, that, but for the simple process of applying the expansive force of gunpowder, we must

have been deprived of innumerable advantages and accommodations. **Blasting.**

When a perforation or hole is to be made in a rock for the purpose of blasting with gunpowder, the prudent quarrier considers the nature of the rock, and the inclination or dip of the strata, and from these determines the calibre, and the depth and direction of the bore or recipient for the gunpowder. According to circumstances, the diameter of the hole varies from half an inch to $2\frac{1}{2}$ inches, the depth from a few inches to many feet, and the direction varies to all the angles from the perpendicular to the horizontal. The implements for the performance of this operation are rude, and so extremely simple and familiar, as hardly to require description; and the whole operation of boring and blasting rocks is so easily performed, that, in the space of a few weeks, an intelligent labourer may become an expert quarrier. The tools are few in number, and, as just said, are simple in their construction. The chisel, or *jumper*, as it is technically called, varies in its length and other dimensions according to the work to be performed, and its edge is more or less pointed to suit the hardness or tenacity of the rock to be bored. If the cylindrical hole to be drilled is of small diameter and of no great depth, or the work fixed to a confined position, as often happens, the operation of boring is performed by a single person; with one hand he manages the chisel or jumper, which he keeps constantly turning, and with the other he strikes the jumper with a hammer of 6 or 8 lb. weight. But when the hole is of larger dimensions, and of a depth exceeding a foot, it generally becomes the business of one man, in a sitting posture, to hold and direct the jumper,—to keep it constantly turning,—to supply the hole with water, and occasionally to clean it out; while two and even three men, with hammers of 10 or 12 lb. weight, strike successive blows upon the jumper, until the rock is perforated to the desired depth. To prevent annoyance to the quarriers from the squirting up of the water, a small rope of straw or hemp is simply twisted round the jumper, and kept resting on the orifice of the hole. When the perforations are to be made to a greater depth than about 30 inches, it is now common to use a chisel or jumper, varying in length from 6 to 8 feet, pointed at both ends, having a bulbous part in the middle for the convenience of holding it; it thus becomes a kind of double jumper, and is used without a hammer, with either end put into the hole at pleasure. When a bore of considerable depth is to be made, after the hole has been perforated a few inches with the common jumper, the quarriers lay it and their hammers aside, and collect round the *long jumper*, in a standing posture, and lay hold of it by the bulbous part, lifting and letting it drop into the hole by its own gravity; in this manner, by the successive strokes or falling of the long jumper, a hole to the depth of five feet and upwards is perforated, with much ease to the workmen, and with wonderful expedition. When the boring of the hole is completed, the *debris* and moisture are then carefully cleaned out, and a proper

Blasting. charge of powder is put into it. In practice, there is no very precise rule for the charge or quantity of gunpowder, this being regulated at the discretion of the quarrier, according to the tenacity and mass of the rock to be removed; and these circumstances having been previously considered, in the dimensions of the bore, it is customary to fill it in the proportion of about one half with gunpowder.

The charge being introduced into the cylindrical hole bored or drilled in the rock, a long iron called the *pricker* is inserted amongst the powder, to be afterwards withdrawn when the priming powder is introduced. While this rod remains, the process of *ramming* or *stemming* the hole is performed by forcing burnt clay, fragments of pounded brick, stone, or any other substance less liable than another to produce sparks of fire on being struck with iron. After a layer or stratum of such matter has been pressed down upon the powder, the remaining depth of the hole is filled with pounded stone or earthy matters of any kind, forced down with an iron punch or rammer of such dimensions that it nearly fills the hole, but having a groove in it to receive the pricker; the rammer being flat at the end which enters the hole, the fragments of stone are pounded by it round the pricker, which must be occasionally turned to prevent it from being too firmly fixed, and thereby prevented from being drawn. This wadding or matter, laid immediately over the powder, is gently forced down at first, to prevent, as much as possible, the danger of premature explosion; but as the hole is more and more filled up, the quarrier strikes down the stemmer with more violence and less care, and consolidates the wadding as much as possible, with a view to produce a greater effect by the shot. In this operation consists the chief danger attending the process of blasting with gunpowder; for it must be obvious, that, unless the utmost care be taken in forcing down the first portions of the wadding above the powder, there is great danger of such a collision taking place, between the stemmer and the pricker, or between either of these and the rock or sides of the hole, as may elicit a spark of fire, and produce unintentioned explosion. From this cause, indeed, the most unfortunate and distressing accidents have sometimes happened to quarriers. A recent case occurred under the notice of the writer of this article, from which an experienced workman lost the sight of both eyes, and had his legs and arms much shattered. It is necessary, as before noticed, frequently to turn the pricker during the process of stemming the shot, in order to prevent its being withdrawn; and it has been known that, by the friction produced in the mere act of turning it unguardedly, the shot has been fired off. To prevent accident in this way, copper prickers, or, to save expence, prickers composed partly of copper and partly of iron, have been introduced, instead of those formed wholly of iron. The copper pricker is certainly much less liable to accident; but notwithstanding that this fact is self-evident, and has been clearly established in quarries where copper and iron prickers have been used at the same time, yet, from the greater ex-

pence of the copper, and its being more liable to twist and break, it has by no means come into general use.

The hole being now fully charged with the powder and wadding, the pricker is drawn out. The small tubular space, which it leaves, is sometimes wholly filled with powder, but with a view to save that expensive article, it is now common to insert wheaten or oaten straws filled with powder. These straw tubes may be joined so as to reach any necessary depth; the lower straw always terminating in the root part where a natural obstruction occurs, or it is artificially stopped with clay, to prevent the powder from being lost. The lower part of the priming straw is pared quite thin, so as to insure the inflammation of the charge of powder in the hole. This being done, a *slow match*, consisting generally of a bit of soft paper, prepared by dipping it into a solution of saltpetre, is carefully applied to the priming powder. When this match is touched with fire, the quarriers give the alarm to all around, to retire to a sufficient distance, so as to avoid accident from the expected explosion. This commonly takes place in about a minute. The priming first explodes, attended only with flame; a short interval of suspense commonly ensues; the eyes of the bystanders being anxiously directed towards the spot; the rock is instantly seen to open, when a sharp report, or a detonating noise, takes place, and numerous fragments of stone are observed to spring into the air, and fly about in all directions, from amidst a cloud of smoke. The quarrier then returns with alacrity to the scene of his operations. When blasting with gunpowder is carried on in coal-pits or in sinking wells, where the workmen cannot get speedily out of the reach of the shot, or in any situation where adjoining houses, &c. may be in danger of being injured, it is common to load or cover up part of the rock to be blasted, with a quantity of furze or brushwood, to prevent the fragments of blasted rock from being driven to a distance.

The simplicity of this operation, so important to our means of quarrying or prying into the bowels of the earth, is, perhaps, one cause of so little attention having been paid to it by persons of science; while the personal risk attending it may have also operated, in some measure, to prevent particular inquiries regarding it. It was an extremely natural conclusion for the quarrier to suppose, that the more firmly the shot was rammed home, the more powerful would be the effect of the explosion. This, we know, was long the conviction of military Engineers; and was also a principle invariably adopted by miners, to the great personal hazard of the artificer. In many places, this notion still prevails, and we cannot enough lament the force, and stubbornness of custom in this instance; as it has been fully established, that a wadding of loose sand, or of any earthy matter in a dry state, answers all the purposes of the firmest ramming or wadding. Now, as it is in the operation of ramming, that accidents most commonly befall the quarrier, and which the use of the copper pricker cannot altogether prevent, it is not

Blasting. a little surprising, that the use of sand does not become universal.

To the common-labourer, indeed, it naturally seems somewhat paradoxical to say, that particles of loose sand can produce an effect equal to stemming a shot with an iron punch and hammer; but those who are better informed, should insist on the use of sand, whereby the person of the quarrier would be much less exposed, and much time and trouble would be saved. It may be noticed, that in several works this is observed, particularly at Lord Elgin's extensive mining operations at Charlestown in Scotland, where much attention is paid to the security and comfort of the artificer, as well as to every thing interesting to science. The practice of using loose sand instead of pounded stone rammed with force, has been in use at these works for several years (it is believed since about the year 1810). The writer of this article has also had considerable opportunities of trying the accuracy of these statements, as to the efficiency of sand, at the extensive quarrying operations which lately became necessary in cutting down a part of the Caltonhill, in forming the new approach to the city of Edinburgh, where upwards of 100,000 cubic yards of rocky matters were removed, and gunpowder to the value of nearly L. 1000 Sterling, was expended, chiefly in blasting rock, consisting of whinstone, or greenstone, much traversed by calcareous spar. The holes at this work were bored of various dimensions, both as to calibre and depth, and also at all the angles of inclination, from the perpendicular to the horizontal. Trials were here made with holes from three to seven or eight feet in depth, and of a diameter from an inch to two and a half inches in diameter; when it was invariably found, that when the powder was wadded with sand, the effect in tearing or blasting the rock was as great as when the more commonly followed method, of ramming with pounded stone was adopted. In the judgment of the Contractors, the fragments of rock had a greater tendency to fly to a distance when sand only was employed; but there was as great a bulk of the rock raised by the shot wadded with sand as by that which was rammed in the usual way; and in practice it was found that the shots with sand were not more liable to fail, or blow, without doing execution, than those which were rammed. It is a fact perhaps as curious and interesting as any connected with the subject, that in both ways the shots fail, and at times blow out, without producing any effect, or being occasioned by any apparent cause. Reasoning from the simultaneous effects of the sudden extrication of the elastic fluid of gunpowder, whether a wadding of loose sand or of firmly pounded stone be employed, trial was made of gunpowder without any wadding, but the effect produced by this method was rather to shake or rend the upper part, near the orifice of the hole or surface of the rock, than at the bottom of the hole. This fact, however, favours the conclusion that the explosive force of gunpowder is in proportion to the surface upon which it acts; and that the effect is so instantaneous, that it seems a matter not essentially connected with the operation, in what

Blasting. manner the wadding is effected, provided that the atmospheric air is not in immediate contact with the powder; as otherwise the fluid appears to divide, and its effects to be lost in space, without being applied chiefly at the bottom of the hole, where the greatest execution is wished to be done.

It may be noticed, that although the use of sand for blasting in mining operations is by no means general, yet so much of this practice has obtained, that the quarrier is now only at pains to ram an inch or two of the lower wadding firmly home; the upper parts are done loosely, with little attention either to the stuff employed, or to the ramming of it; he merely consolidates it in such a manner, that the broken particles shall not fall into the charge amongst the powder, when he withdraws the pricker. In so far, this is a saving of time; but unfortunately he still undergoes much personal risk, the chief danger being in ramming at first, or in the turning or withdrawing of the pricker, where the wadding is firm. When sand is used immediately above the powder, both the pricker and the rammer are wholly unnecessary; the primed straw being inserted into the powder, the sand is poured into the hole, and the shot is ready for the match. A difficulty occurs in the use of sand, which, though easily surmounted, it may be proper to notice in this place. When the hole or perforation in the rock happens to be horizontal, or at more than an angle of 45° from the perpendicular, the priming straw is apt to be injured in filling the hole with sand, an evil to which the pricker is not liable; but this is easily got over by inserting the priming straw into a small cylindrical tube of sheet-iron or copper, while the sand is gently pressed into the hole; the small tube which is open at both ends is afterwards withdrawn. By this means, the operation of the horizontal shot is rendered not less sure, and is attended with no more expence, and little more trouble, than when the bore is perpendicular.

It has been supposed by some, that a more complete inflammation of the powder would take place, if it were ignited at the bottom of the hole; but it has been found by experience, that this is not essential. It even appears from experiment, that gunpowder is more fully inflamed by applying the fire near the top, for in firing Ordnance, considerable quantities of the unflamed grains of the powder have been collected, by placing a piece of cloth at a distance from the gun, and allowing the shot to pass through it.

Quick-lime, suddenly slacked, has been suggested as a mode of rending rocks; but this process would in practice be found very defective. In some situations where the explosive effects of gunpowder could not be applied with safety, as in the interior of a building, or for such like purposes, this mode may be resorted to with good effect.

Blasting with gunpowder, under water, is necessarily performed in various operations of the Engineer, particularly in the excavation of the foundations of piers, and in deepening the entrances of harbours. This is performed by inserting the charge of powder into the perforated rock, by means of a

Blasting
Bleaching.

case or cartridge made of tin-plate. The lower part is made to fit the bore in the rock, as nearly as may be; from this a small pipe of the same metal is carried to the surface of the water, with the priming powder. Here wadding is unnecessary, the pressure of the water upon the tin case superseding the necessity of any; and the explosive effects are generally greater, in proportion to the charge, than those in the open air. It may here be observed, that explosions under water have, in some instances, been proposed as a mode of attack in marine warfare; and it is presumed, that explosions, at considerable depths, might occasion such an impression on the water, and so disturb the equilibrium of the atmospheric pressure, as to be capable of sinking large ships, or floating batteries.

Blasting
Screw.

It may also be mentioned, that a new instrument, called the *Blasting Screw*, has been lately applied with considerable success to the rending or splitting of large trees and logs of timber. It consists of a screw which is wrought into an auger-hole, bored in the centre of the timber; here the charge of powder is

Blasting
Bleaching.

inserted, and the orifice of the hole in the log is then shut up or closed with the screw, when a match, or piece of cord, prepared with saltpetre, is introduced into a small hole left in the screw for this purpose, by which the powder is ignited. The application of this screw to the purposes of blasting is not very obviously necessary, because, from what we have seen, it would appear that the auger-hole being charged with powder and sand, would answer every purpose. One great objection to the process of blasting applied to the rending of timber is, the irregular and uncertain direction of the fracture, by which great waste is sometimes occasioned. It may, however, be necessary to resort to this mode of breaking up large trees, when cut down and left in inaccessible situations, where a great force of men and of implements cannot easily be procured or applied.

See *Treatise of Artillery* by John Muller; *Hutton's Mathematical Dictionary*; and *Nicholson's Journal*, Vols. XII. and XIII. (H. H.)

BLEACHING.

BLEACHING is the art of whitening thread and cloth. It has been treated at considerable length in the *Encyclopædia*. Our business here is merely to supply the defects of that article. These are chiefly two; namely, 1. A very incomplete historical detail of the improvements in bleaching, at least as far as this country is concerned; and, 2. The omission of any description of the present mode of bleaching, as practised by the most enlightened manufacturers of Great Britain.

History.

I. The Ancients, especially in Egypt, where white linen was a common article of clothing, must at an early period have been acquainted with the method of bleaching that substance, but none of their writers have left us any details on the subject. We know, however, from Pliny, that different plants, and likewise the ashes of plants, which no doubt contained alkali, were employed as detergents. Pliny mentions particularly the *struthium* as much used for bleaching in Greece. This plant has been considered by some as the *gypsophila struthium*. But as it does not appear from Sibthorp's *Flora Græca*, published by Sir James Smith, that this species is a native of Greece, Dr Sibthorp's conjecture that the *struthium* of the Ancients was the *saponaria officinalis*, a plant common in Greece, is certainly more probable. Mr Parkes, in his *Essay on Bleaching* (*Chemical Essay*, Vol. IV. p. 7), says, that Theophrastus states that lime was used by the ancients in bleaching; and that a ship, partly loaded with linen, and partly with lime for bleaching it, was destroyed by the accidental access of water to the lime. We endeavoured, with some pains, to verify this quotation; and, for this purpose, turned over all the writings of

Theophrastus with which we are acquainted, without being able to find any thing bearing the least allusion to it. We have doubts whether lime could be employed as a detergent of linen, without injuring the texture of the cloth; and, on that account, it would have gratified us exceedingly to have found such a statement in so respectable and correct a writer as Theophrastus.

About sixty or seventy years ago, the art of bleaching was scarcely known in Great Britain. It was customary to send all the brown linen manufactured in Scotland to Holland to be bleached. It was sent away in the month of March, and not returned till the end of October, being out of the hands of the merchant more than half a year. The principal Dutch bleaching-grounds were in the neighbourhood of Haerlem; and the great success of their bleachings was ascribed to the superior efficacy of their water, which, according to the fashionable theory of the time, was sea-water filtered and rendered sweet, by passing through their sand-downs. Indeed, it was long a prejudice on the Continent, that no water was efficacious for bleaching but sea-water.

The Dutch mode of bleaching was to steep the linen for about a week in a potash ley poured over it boiling hot. The cloth being taken out of this ley, and washed, was next put into wooden vessels containing butter-milk, in which it lay under a pressure for five or six days. After this it was spread upon the grass, and kept wet for several months, exposed to the sunshine of summer.

In the year 1749, as we are informed by Mr Parkes (*Chemical Essays*, Vol. IV. p. 26), an Irishman, who had learned something of the art of bleaching, settled in the north of Scotland, and es-

Bleaching, published a bleaching manufactory. On applying to the principal Scotch makers of linen, they readily furnished him with a quantity of goods; but after keeping them a whole year, he failed in all his endeavours to bleach them, and the proprietors were obliged to send them to Holland to get the process completed. Next summer his efforts were not more successful; the linen was considerably injured, and even rendered tender by his management, but it was not whitened. Nevertheless, this man by perseverance became in a few years an excellent practical bleacher. He had the merit of introducing the art into Great Britain, and his descendants at this day figure among the higher ranks in the metropolis.

The bleaching process, as at that time performed, was very tedious, occupying a complete summer. It consisted in steeping the cloth in alkaline leys for several days, washing it clean, and spreading it upon the grass for some weeks. The steeping in alkaline leys, called *bucking*, and the bleaching on the grass, called *crofting*, were repeated alternately for five or six times. The cloth was then steeped for some days in sour milk, washed clean, and crofted. These processes were repeated, diminishing every time the strength of the alkaline ley, till the linen had acquired the requisite whiteness.

For the first improvement in this tedious process, which was faithfully copied from the Dutch bleach-fields, manufacturers were indebted to Dr Home of Edinburgh, who proposed to substitute water, acidulated with sulphuric acid, for the sour milk previously employed. This suggestion was in consequence of the new mode of making sulphuric acid, contrived some time before by Dr Roebuck, which reduced the price of that acid to less than one-third of what it had formerly been. It is curious, that when this change was first adopted by the bleachers, there was the same outcry against its corrosive effects as we have seen some years ago, when oxymuriatic acid was substituted for crofting. No allegation, however, could be worse founded, and it was completely destroyed by the publication of Dr Home (*Essay on Bleaching*), who demonstrated the perfect innocence and the superior efficacy and cheapness of sulphuric acid, when properly applied, over sour milk. Another advantage resulted from the use of sulphuric acid, which was of the greatest importance to the merchant. A souring with sulphuric acid required at the longest only twenty-four hours, and often not more than twelve; whereas, when sour milk was employed, six weeks, or even two months, were requisite, according to the state of the weather. In consequence of this improvement, the process of bleaching was shortened from eight months to four, which enabled the merchant to dispose of his goods so much the sooner, and consequently to trade with so much less capital.

The bleaching art remained in this state, or nearly so, till the year 1787, when a most important change began to take place in it, in consequence of a discovery which originated in Sweden about thirteen years before. In the year 1774, there appeared in the *Memoirs of the Royal Academy of Stockholm* a paper on manganese, by Mr Scheele. Among

other experiments to which he subjected this mineral, he mixed it with muriatic acid, put the mixture in a retort, and applied heat. He perceived a smell similar to that of aqua regia. This induced him to collect what came over in a receiver, and he found it to be muriatic acid, altered in a remarkable manner by the action of the manganese on it. Its smell was greatly heightened, it was become less soluble in water, and it possessed the property of destroying those vegetable colours on which it was allowed to act. M. Berthollet repeated the experiments of Scheele on this new acid in 1785, and added considerably to the facts already known. He showed that this new acid (called by Scheele *dephlogisticated muriatic acid*) is a gas soluble in water, to which it gives a yellowish green colour, an astringent taste, and the peculiar smell by which the acid is distinguished. When water, impregnated with this acid, is exposed to sunshine, it gradually loses its colour, while, at the same time, a quantity of oxygen gas is disengaged from the water. If the liquid be now examined, it will be found to contain, not the new acid, but common muriatic acid. This experiment Berthollet considered as exhibiting an analysis of the new acid, and as demonstrating that it is a compound of muriatic acid and oxygen. On that account, he gave it the name of *oxygenated muriatic acid*, which was afterwards shortened into *oxymuriatic acid*, an appellation by which it is still known among bleachers.

The property which oxymuriatic acid possesses of destroying vegetable colours, led Berthollet to suspect, that it might be introduced with advantage into the art of bleaching, and that it would enable practical bleachers greatly to shorten their processes. At what time these ideas first struck his mind, we do not exactly know; but at the end of a paper on dephlogisticated muriatic acid, read before the Academy of Sciences at Paris in April 1785, and published in the *Journal de Physique* for May of the same year (Vol. XXVI. p. 325), he mentions that he had tried the effect of the acid in bleaching cloth, and found that it answered perfectly. This idea is developed still farther in a paper on the same acid, published in the *Journal de Physique* for 1786. In 1786, he exhibited the experiment to Mr Watt, who, immediately upon his return to England, commenced a practical examination of the subject, and was accordingly the person who first introduced the new method of bleaching into Great Britain.

Mr Parkes, in his *Chemical Essays*, published in 1815, has mentioned some facts upon this subject, which it will be proper to state. In the early part of the year 1787, Professor Copland of Aberdeen accompanied the present Duke of Gordon to Geneva, and he was shown the discolouring property of oxymuriatic acid by M. de Saussure. Mr Copland was much struck with the importance of the experiment, and on his return to Aberdeen in July 1787, mentioned the circumstance, and repeated the experiment before some eminent bleachers in his own neighbourhood. These gentlemen were Messrs Milnes of the house of Gordon, Barron, and Company, Aberdeen. They immediately began the application of the process to the bleaching of linen on

Bleaching. a great scale; and Mr Parkes assures us that they were the first persons who applied the new process to practical bleaching in Great Britain.

New Process introduced into Britain by Mr Watt. But this statement, though it may appear plausible at first sight, is quite incorrect. The writer of this article took the liberty of applying to Mr Watt himself for information on the subject. Mr Watt has preserved copies of all his letters since the year 1782, taken by means of his copying machine. He allowed the writer of this article to peruse such of them as bore any reference to this subject. Now, two letters were found, which entirely set the matter at rest. The first of these is to his father-in-law, Mr Macgregor, dated Birmingham, March 19, 1787. In this letter he gives a particular detail of the new bleaching process, states its advantages, and says that he had sent Mr Macgregor a quantity of the whitening liquor. The second letter is to Berthollet, and is dated Birmingham, May 9, 1787. The following is a part of that letter, which we have transcribed verbatim: "Je ne sais pas si j'ai encore fait la liqueur acid si fort que vous avez fait, mais je vous donnerois les moyens de juger. Je trouve que 4 onces de mon acide melé avec la quantité nécessaire d'alkali de pearl-ash peut blanchir un gros de toile brune, telle comme j'ai vu chez vous. Il est vrai qu'il ne la fait tout a fait blanc; mais il le fait aussi blanc, que je puis le faire, meme en ajoutant une second dose d'acide. Je bouille la toile par avance dans une solution d'alkali faible; et à mi blanc, je la bouille une second fois. Je trouve que le savon est meilleur que l'alkali pur pour la second bouillon. J'ai blanchi toute à fait le coton, mais je ne suis encore parvenu à blanchir *parfaitement* la toile de lin." The reader will observe, that the date of both of these letters is some months before Mr Copland's return from the Continent. M. Berthollet had published his process in 1785, and as Watt had brought it to England in the end of 1786, and had put it in practice, and introduced it into Mr Macgregor's bleachfield, near Glasgow, in the month of March 1787, it is clear that Saussure has no claim to the original discovery, nor Mr Copland to the first introduction of the new process into Great Britain.

Dr Henry quotes a letter of Mr Watt, dated 1788, February 23, in which he says, "I have for more than a twelvemonth been in possession and practice of a method of preparing a liquor from common salt, which possesses bleaching qualities in an eminent degree; but not being the inventor, I have not attempted to get a patent or exclusive privilege for it." (*Annals of Philosophy*, VI. 423.) This letter alone is sufficient to show, that Mr Watt's experiments were of an earlier date than those of Messrs Milnes. He says, farther, that "at that very time 1500 yards of linen were bleaching by the new process, under his directions." This great experiment was conducted in the bleachfield of his father-in-law, Mr Macgregor, near Glasgow; where, as he wrote to M. Berthollet, soon after, 500 pieces were bleached by the new method, and Mr Macgregor was so satisfied of the importance of the new process, that he resolved to continue it. Mr Watt made several improvements in the method of M. Berthollet. Instead

Bleaching. of employing muriatic acid and manganese, as had been done by Scheele and Berthollet, he had recourse to the cheaper mode of a mixture of common salt, black oxide of manganese, and sulphuric acid. He made use of wooden vessels to hold the water, which was to be impregnated with the oxymuriatic gas, coating them within with a mixture of wax and pitch, which rendered the air light, and prevented the gas from acting on the wood. Mr Watt likewise contrived a test to indicate the strength of the water impregnated with oxymuriatic acid, as far as its bleaching effects were concerned. He took a determinate quantity of the infusion of cochineal, and ascertained how much of the bleaching liquor was necessary to destroy the colour. The strength of the bleaching liquor was obviously inversely as the quantity necessary to destroy the colour. But M. Welter hit upon another method about the same time, which has been considered as preferable, and has in consequence come into general use. He employed a solution of indigo in sulphuric acid instead of the infusion of cochineal. In other respects the two methods were the same.

Mr Thomas Henry of Manchester began his experiments on bleaching, by means of oxymuriatic acid, nearly as early as Mr Watt, and without any previous knowledge of what he had done. He was very assiduous, and very successful in his trials. At a meeting of the bleachers, held at Manchester, early in 1788, he exhibited half a yard of calico, bleached by the new method, which was considered as superior in whiteness to half a piece of calico, bleached by the same process by Messrs Cooper, Baker, and Charles Taylor. In consequence of this exhibition he was applied to by Mr Ridgway of Horwich, to be instructed in the new process. And the instructions which he accordingly received, were the first step of a series of improvements carried on by Mr Ridgway and his Son, with an ability and spirit of enterprise, which have raised their establishment to its present extent and importance. (See *Annals of Philosophy*, VI. 423.) These two gentlemen, Messrs Watt and Henry, had the chief merit of introducing the new mode of bleaching into Lancashire, and the neighbourhood of Glasgow.

In the year 1789, M. Berthollet published a memoir on the subject, in the second volume of the *Annales de Chimie* (p. 151). In this memoir, which constituted the first publication on the mode of bleaching by means of oxymuriatic acid, Berthollet gives a detail of the progress of his experiments, and states the attempts that had been made to introduce the new mode of bleaching into France. M. Bonjour, who had assisted him in his experiments, associated himself with M. Constant, a manufacturer of cloth at Valenciennes, to form a bleaching establishment in that city upon the new plan. But their project was prevented by the prejudices of the inhabitants, and by the jealousy of the bleachers, who were afraid of being injured by the introduction of any new improvements. M. le Comte de Bellaing, however, who approved of the project, granted a piece of ground possessed of all the requisite conve-

Bleaching. niences; but rather at too great a distance from Valenciennes. M. Bonjour applied to the Board of Commerce for the exclusive privilege of bleaching for some years, according to the new method in Valenciennes and Cambrai, and for two leagues around these places, offering at the same time to explain the new process in all its details to those who wished to make themselves acquainted with it. But the request was refused.

It does not appear, from Berthollet's account, that the new mode of bleaching had been able to establish itself in any manufactory in France, before the publication of his Memoir. One of the great difficulties in the way of applying oxymuriatic acid to bleaching was the very disagreeable and noxious odour which characterizes it, and which rendered it not only very offensive, but highly injurious to the health of the workmen. He describes, at considerable length, a vessel contrived for impregnating water with it, by M. Welter, and likewise the mode of preparing the gas from common salt, black oxide of manganese, and sulphuric acid. But his improvements, though considerable, were far from obviating the inconveniences complained of. Some method was wanted which should deprive water impregnated with this gas of its smell, without depriving it of its bleaching qualities. The first attempt to accomplish this object originated from M. Berthollet himself.

When he first began to bleach, by means of water impregnated with oxymuriatic acid, he employed that liquid as concentrated as possible; but he found that the texture of the cloth steeped in this liquid was considerably injured. To prevent this effect, he at first added a little alkali to the liquid, to saturate a portion of the acid. But he found afterwards that it was better to dilute the liquid with water. Before this last method occurred to him, he was requested to go to Javelle, to show the bleachers there, the method of preparing the oxymuriatic acid, and making the bleaching liquor. He went twice in consequence, prepared the liquor before the bleachers, and added some potash to prevent the acid from injuring the texture of the cloth. Sometime after the manufacturers of Javelle announced in the different journals that they had discovered a peculiar liquid which they called *Lessive de Javelle*, and which possessed the property of bleaching cloth immersed in it for a few hours. This liquid they prepared by dissolving potash in the water which they were going to impregnate with oxymuriatic acid. The consequence was, that the liquid absorbed a much greater quantity of gas, and might be diluted with a considerable proportion of water, without losing its bleaching quality.

Being disappointed in their attempts to introduce this liquor among the French bleachers, they came over to England, and applied to Parliament for the exclusive privilege of supplying the British bleachers with this liquid. The patent was to be given to MM. Bourbollon de Bonnueil and Company. In consequence of this application, a meeting of the bleachers of Lancashire was advertised, in the beginning of the year 1788. It was at this meeting

that Mr Henry exhibited the half yard of calico Bleaching. bleached according to the new method. Mr Watt had written a letter to Dr Percival on the subject, which was communicated to the meeting. He stated in it that he had been in possession of a new method of bleaching, by means of oxymuriatic acid, for above a year; that he had learned it from Berthollet, and that he had every reason to believe that the liquor of MM. Bourbollon de Bonnueil and Company, consisted of oxymuriatic acid, or of some proportion of it. In consequence of this meeting, the county members of Parliament were requested to oppose the intended monopoly. Mr Watt also exerted all his influence; and Mr Parkes informs us likewise, that one of the Messrs Milnes of Aberdeen, who had been informed of the use of oxymuriatic acid by Mr Copland, happened to be in the gallery of the House of Commons when this application in favour of these gentlemen was made. He took immediate measures to inform the principal members that this was not a new process; that he himself had long ago prepared an article equally advantageous, and that he was ready to substantiate the truth of his statement when required. (Parkes's *Chemical Essays*, IV. 62.) In consequence of the united exertions of all these different gentlemen, the bill was thrown out, and the monopoly prevented.

It seems to have been partly in consequence of this application of the French gentlemen that Mr Henry of Manchester was induced to attempt bleaching in the large way with oxymuriatic acid. His attention had been first drawn to the subject by the papers of Berthollet, published in the *Journal de Physique*, during the years 1785 and 1786. He was at that time engaged in a course of lectures on Dyeing, Printing, and Bleaching. An acquaintance with the properties of oxymuriatic acid, which he had repeatedly had occasion to exhibit in his course of lectures, and the general hints previously thrown out by Berthollet, led him to conclude, that the liquor of Bourbollon and Company could be nothing else than oxymuriatic acid, or some compound of it. His first operations on the large scale consisted in exposing the goods, in a moist state, in air-tight chambers, to the action of oxymuriatic acid gas. He likewise began to prepare for sale a bleaching liquor, in which the gas was condensed in a very weak solution of potash; which, as we learn from Berthollet, was the very same with the *Lessive de Javelle*. This liquid possessed two advantages over water simply impregnated with oxymuriatic gas. Its smell was less noxious, and it might be employed to whiten printed calicos without destroying the colours which had been dyed upon the cloth. But these advantages were much more than counterbalanced by equivalent disadvantages. It was found not to go nearly so far as water impregnated with oxymuriatic acid, and when kept for some time, it lost its bleaching properties altogether. The reason of this last alteration is now sufficiently understood; the oxymuriatic acid in the liquid was gradually destroyed, and converted into common muriatic acid and chloric acid; the water containing merely common muriate of potash and chlorate of potash. In some-

Bleaching. quence of these disadvantages, the addition of potash to the bleaching liquid was soon laid aside.

The next attempt to destroy the noxious smell of the liquid, without destroying its bleaching property, was the addition of lime to the liquid. Mr Henry of Manchester was one of the first persons who thought of this addition. On the floor of his air-tight chambers rested a stratum of thin cream of lime, through which the goods were passed by means of a wince; and were afterwards exposed, on quitting the liquor, to oxymuriatic acid gas. Hence the oxymuriate of lime was formed upon the cloth. But this method was objectionable in the case of some coloured goods, the colours of which were injured or destroyed by that earth. It admitted, therefore, of only a partial application.

Other persons made similar attempts, but none of them appear to have been attended with success. But Mr Tennant of Glasgow, after a great deal of most laborious and acute investigation, hit upon the method of making a saturated liquid of oxymuriate of lime, which was found to answer perfectly all the purposes of the bleacher. This was certainly a most important improvement. Without it, the prodigious extent of business carried on by some of our bleachers could not possibly have been transacted. To give some idea of the rapidity with which bleaching is conducted according to the new process, we may mention the following fact, which we state on what we consider as very good authority. A bleacher in Lancashire received 1400 pieces of grey muslin on a Tuesday, which on the Thursday immediately following were returned bleached to the manufacturers, at the distance of 16 miles, and they were packed up and sent off on that very day to a foreign market. The quick return of capital which is thus made is a benefit entirely to be ascribed to the new mode of bleaching.

In the year 1798, Mr Tennant took out a patent for his new invention, and offered the use of it to practical bleachers, for a fair and reasonable portion of the savings made by its substitution for potash, then in general use. Many of the bleachers, however, used it without paying him, and a combination was formed to resist the right of the patentees. In December 1802, Mr Tennant and Company brought an action for damages against Messrs Slater and Varley, the nominal defendants; but who, in fact, were backed and supported by a combination of almost all the bleachers in Lancashire. In consequence of this action, the patent right was set aside by the verdict of a jury and the decision of Lord Ellenborough, who used very strong language against the patentees. The grounds of this decision were, that the patent included a mode of *bucking* with quicklime and water, which was not a new invention. It was decided that, because one part of the patent was not new, therefore the whole must be set aside. Had the writer of this article constituted the jury, the verdict would have been very different. Lime was indeed used previous to the patent of Mr Tennant; but it was employed in a quite different manner from his, and he would have allowed all of them to continue their peculiar method without any

objection or injury to his emolument. If the very same process as that of Mr Tennant was employed before he took out his patent, there could be no doubt that the process originated with him, and that those who used it had been induced to do so from the information which they derived from him. In the opinion of the writer of this article, Mr Tennant was hardly used, and the words employed by Lord Ellenborough were quite inapplicable to him. But when a very powerful combination is formed against any individual, the sentiments with which they are actuated propagate themselves with rapidity, and it is difficult for the most upright jury to avoid being swayed by prejudices so much the more formidable, because their existence is not perceived.

In consequence of this decision, the use of liquid oxymuriate of lime in bleaching was thrown open to all, and appears now to be universally employed by all the great bleachers in Britain. Mr Tennant, thus deprived of the fruits of several years of anxious and laborious investigation, advanced a step farther, to what may be considered as the completion of the new method. This consisted in impregnating quicklime in a dry state with oxymuriatic acid. He had taken out a patent for this on the 13th of April 1799, and his right fortunately was not contested. He began his manufactory of solid oxymuriate of lime at first upon a small scale, which has been ever since gradually extending, and is now very considerable indeed. During the whole period of the duration of his patent, he laboured under great disadvantages. The oxymuriatic acid gas with which the lime was impregnated, was obtained from common salt. Now, his patent did not extend to Ireland, in consequence of which, manufactures of dry oxymuriate of lime were established in that kingdom. In Ireland, the manufacturer obtained his salt-duty free, while in Scotland Mr Tennant was obliged to pay a duty of 7s. 6d. per bushel. Such, however, was the superiority of the methods employed by Mr Tennant, that he was able to compete with the Irish manufacturers in their own country.

In the year 1815, in consequence of the joint application of the bleachers, the duty on common salt, formerly charged upon all bleachers and others who employed that article in the preparation of a bleaching liquid, was taken off, and they were henceforth allowed to use it duty free. But this act, while it affords great advantages to bleachers on a large scale, precludes those who only work on a small scale, from making their own oxymuriate of lime; the consumption of the powder, therefore, is likely to increase very much among the little bleachers and calico printers. Its use is also considerable in partially discharging the colour of Turkey red cloth. The method was originally a French invention; but a patent has been lately granted to Mr Thomson, a Lancashire bleacher, for the process, which, we believe, he imported from Iony. The method is this: An acid paste, consisting of citric acid, or any other acid thickened with gum, is first printed on the Turkey red cloth, which is then passed through liquid oxymuriate of lime. It becomes white only where the acid was applied. On this bleached part any

Bleaching.

Bleaching. other colour may be applied, and the combinations produced are exceedingly beautiful and striking.*

Such, as far as we are acquainted with the subject, is the history of the progress of the new method of bleaching in Great Britain. We have said nothing of the Irish bleachers, because we are not particularly acquainted with the progress of the new method in that country; though we believe that oxymuriatic acid was tried by the Irish bleachers almost as early as it was in Great Britain. Mr Parkes supposes that Mr Kirwan might have proposed the trial of the new reagent, in consequence of some suggestion from Scheele or Saussure. (*Parkes's Chemical Essays*, IV. 43.) But we have no evidence that this was the case. Indeed, it would be quite unreasonable to attempt, by such vague suspicions, to detract from the merit due to Berthollet for his original suggestion of the application of oxymuriatic acid to bleaching,—a merit which he has enjoyed without a competitor for 30 years. Scheele was dead before any one attempted to introduce the new acid into bleaching, either in Great Britain or Ireland. And there is every reason for believing that Saussure's knowledge of the bleaching qualities of oxymuriatic acid, originated from Berthollet's publications on the subject in 1785 and 1786.

There are three different ways of employing oxymuriatic acid in bleaching, still followed by different manufacturers; the first, the simplest, and we may add, the most economical and efficacious mode, is to impregnate water with oxymuriatic acid, and to use this liquid without any addition in a sufficiently diluted state. Mr Rupp, long ago, demonstrated the superior economy of this process, and even at present it is used by the great house of Oberkampf, Widmer, and Company, of Iony, near Versailles, who have contrived a very ingenious apparatus for its preparation. The only objection to this mode of using the gas, is its suffocating odour, which renders it injurious to the health of the workmen employed.

But the method universally employed by the great bleachers of Britain and Ireland, is to form a liquid oxymuriate of lime, and to immerse the goods in it. The gas is always obtained from common salt, by the joint action of sulphuric acid and black oxide of manganese. Various proportions of these ingredients have been recommended by different persons; but none of them seem to have founded their numbers on scientific considerations. Berthollet, in his dissertation on this subject, pub-

lished in 1789 (*Annales de Chimie*, II. 165), recommends the following proportions as the best:

6 parts of black oxide of manganese,
16 parts of common salt,
12 parts of sulphuric acid,
8 or 12 parts of water.

Boullon La-Grange, in his *Elementary Chemical work*, recommends

3 parts of common salt,
2 parts sulphuric acid,
1 part of black oxide of manganese,
2 parts of water.

Mr Rupp directed

3 parts of manganese,
8 parts of common salt,
6 parts of sulphuric acid,
12 parts of water.

Mr Tennant of Glasgow directs

3 parts common salt,
3 parts of manganese,
3 parts of sulphuric acid,
3 parts, by measure, of water.

The usual proportions in France are,

3 parts manganese,
10 parts common salt,
7 parts sulphuric acid,
9 parts water.

The numbers recommended by Mr Dalton, as agreeing with the atomic theory, are,

100 sulphuric acid of the specific gravity 1.850,
76 water,
40 common salt,
35 black oxide of manganese.

These numbers are founded on the supposition, that two atoms of sulphuric acid are requisite to disengage one atom of muriatic acid from common salt, which, at the common temperature of the atmosphere, or when the heat of boiling water is only applied, is probably true; though at higher temperatures we know, that one atom of sulphuric acid will drive off one atom of muriatic acid. If we consider the state of the common salt, as it is employed, and the frequent impurity of the oxide of manganese used, pro-

* We may notice here, what we consider as a very improper restriction in the new act of Parliament, which takes off the duty on the common salt used by bleachers. They are prohibited from using the rock-salt as it is dug out of the mine, but must employ what has been refined, and which, of course, amounts to four times the price. Surely the framers of the act might have easily seen that, if it was their object to prevent smuggling, it would have been answered much better by prohibiting the use of refined salt, than by restricting the bleachers to it. It would be impossible to smuggle rock-salt without actually refining it, which no bleacher could do without the certainty of detection. Indeed, such a smuggling trade could only be followed on a scale totally below the attention of a bleacher.

Since the preceding note was written, this absurd restriction has been withdrawn, and the use of rock-salt permitted.

ably the bleachers would find the following proportions the most economical and advantageous:

2 parts sulphuric acid,
2 parts water,
1 part common salt,
1 part black oxide of manganese.

At present there can be no doubt that the proportion of common salt used by the bleachers is too great. It is well known, that what remains in the stills after the process, contains still a considerable proportion of muriatic acid. Thus Mr Wilson found the salt which crystallized in the liquid residuum, after distillation, was composed of

Sulphate of soda,	55.47
Muriate of manganese,	26.79
Muriate of lead, -	1.52
Water, -	16.22
	<hr/>
	100.00

This residue was obtained from a mixture of

3 parts common salt,
1 part black oxide of manganese,
4 parts sulphuric acid of the sp. gr. 1.500.

See *Annals of Philosophy*, I: 365.

Dr Henry of Manchester found very large proportions of common salt and muriate of manganese in the residue left after distillation; and he informed the writer of this article, that he had known a bleacher, when in want of common salt, to work twice from the same ingredients, by adding fresh manganese and oil of vitrol. This is a sufficient proof that vastly too much common salt is employed. Indeed, the consumption of common salt by the bleachers is enormous. One bleacher in Lancashire, for example, uses, every six weeks, four waggon loads of common salt, each load containing 3 tons 13 cwt. This is almost at the rate of two tons and a half of salt per week. He employs, for his process, 22 leaden stills, each 22 inches deep, and about 2 feet 4 inches in diameter. Eleven of these are worked on alternate days.

The temperature of steam, under the pressure of the atmosphere, is sufficient to expel the whole of the oxymuriatic acid, and nothing is gained by employing a stronger heat. Accordingly, the stills are universally heated by steam. The calculation is, that 25 square feet of surface in the boiler, is sufficient to heat six stills of the dimensions given above, into each of which are put 112 lbs. of common salt. The gas is received into cream of lime, in which the lime is kept suspended by mechanical agitation. When the process is finished, the undissolved lime is allowed to subside, and the clear liquid is drawn off. Its specific gravity is, generally, about 1.0125. Liquid of this strength is usually mixed with five or six times its bulk of water, before the goods are immersed in it. It has been said, that muriate of lime always injures the texture of cloth immersed in it. But this is true only when the solution is concentrated, and when it is used boiling hot; but

by no means applies to the processes of the bleacher.

The third state in which the oxymuriatic acid is employed by bleachers, is combined with lime, constituting dry oxymuriate of lime. Hitherto the manufacture of this salt in Great Britain has been confined to Mr Tennant of Glasgow, the inventor of the process. But his patent being now at an end, other persons have begun to make it in the neighbourhood of Manchester. For the manufacture of this salt, leaden stills are employed similar to those used in making liquid oxymuriate of lime, and likewise cast-iron stills. The gas is conveyed into a close wooden vessel, on the bottom of which is spread some quicklime, newly slaked and sifted. As the gas passes over, it combines with the lime, and gradually forms the salt required. It is a soft white powder, possessing little smell. When heated it gives out oxygen gas; but if it be mixed with sulphuric acid, oxymuriatic gas is given out when the heat of a lamp is applied. It is partially soluble in water, and the solution gradually disengages bubbles of oxygen gas, while the salt is changed into common muriate of lime. This change appears to take place gradually, even when the salt is kept in a dry state. Mr Dalton has analyzed this salt, and found it composed of

Oxymuriatic acid,	23 or 1 atom,
Lime, -	38 or 2 atoms,
Water, -	39 or 6 atoms,
	<hr/>
	100

When the salt is dissolved in water, one-half of the lime is precipitated, so that the compound which was formerly a subchloride of lime, is now converted into a chloride. Its constituents are,

Oxymuriatic acid,	54.7 or 1 atom,
Lime, -	45.3 or 1 atom.
	<hr/>
	100.0

When a current of oxymuriatic gas is passed to saturation through water in which lime is suspended, a bichloride of lime is formed. It is composed of

Oxymuriatic acid,	70.7 or 2 atoms,
Lime, -	29.3 or 1 atom.
	<hr/>
	000.0

See *Annals of Philosophy*, I. 15, and II. 6.

From Mr Dalton's experiments, the oxymuriate of lime of commerce contains one-third of its weight of common muriate of lime; but this portion varies according to the age of the salt, always increasing, till at last the whole is converted into common muriate of lime.

II. In the article BLEACHING in the *Encyclopaedia*, Present very copious extracts have been given from Kirwan, Method of Berthollet, Decharmes, O'Reilly, Rupp, &c. with descriptions and drawings of the different apparatus recommended by them. But the reader of that article will be at a loss to form any idea of the method

Bleaching. of bleaching at present employed by the most enlightened bleachers in Great Britain. On that account, we conceive that it will be requisite to give a concise sketch of the different processes as they occur in a practical bleachfield. We shall omit most of the descriptions of apparatus, which would oblige us to repeat many things contained in the article to which this is a supplement. The bleaching apparatus is sufficiently simple to be easily conceived by the reader without many particular descriptions. Cotton being much more easily bleached than linen, it will be requisite (though the processes are nearly the same) to give the method of bleaching each separately, because the quantity of materials employed differ for each.

1. Bleaching of Linen.

It would appear from the new process of Mr Lee, who separates the woody matter from the fibre of flax without steeping it, by means of mechanical action, and then bleaches his flax by simply washing it in warm water, that the colouring matter is not chemically combined with the fibrous matter, while the plant is vegetating, or after it is pulled, but that the chemical combination takes place while the plant is steeped in water. The object of this steeping is to induce a fermentation, which loosens and destroys a cement which bound the fibres of flax to each other and to the wood. This fermentation weakens considerably the strength of the flax fibres, and even destroys many of them. Mr Lee's process, therefore, if it be practicable on a large scale, would be a prodigious improvement. It would render the flax fibres much stronger, it would increase their quantity, and it would save the expence of the materials employed in bleaching the linen. The writer of this article has been informed that Mr Lee's process has uniformly failed of success, when tried in Ireland. If this account be true, it is extremely difficult to explain it. We have seen Mr Lee's process performed by workmen under his own direction at Old Bow, near London, with the most complete success; not merely upon handfuls of flax, but upon whole fields of it. Indeed, the whole is so extremely simple, that we cannot well see how it should fail, if properly conducted. We cannot, therefore, help suspecting that the prejudices of the Irish, with which it would have to contend, have been too powerful for it; but that, as soon as it shall meet with fair play, it will be found just as practicable, and certainly much cheaper and better, than the methods at present in use.

It is during the steep, then, that flax acquires its permanent dark colour; and four processes, which we shall now briefly describe, are requisite to restore it to its original white colour, or to separate the colouring matter, which is chemically combined with the fibres of the flax.

1. When the flax is converted into thread, it is repeatedly moistened with the saliva of the spinner, which leaves attached to it a quantity of albumen. When the thread is woven into linen, it is covered with the weaver's dressing, which consists of a paste, made of flour and water. The first step of the bleacher's process is to remove these foreign bodies,

that the colouring matter of the flax itself may be laid open to his subsequent operations. For this purpose, the goods are immersed in warm water, or in a warm alkaline ley, which has already been used in the bleaching processes to be described immediately. In this situation they are allowed to remain till some degree of fermentation appears on the surface of the liquid with which they are covered. This appearance takes place sooner or later, according to the nature of the goods and the heat of the weather, and it is allowed to continue longer or shorter according to circumstances. The goods are then taken out, and well washed in pure water, which now removes all the foreign matter added during the spinning and weaving.

2. The second process consists in exposing the goods to the action of alkaline leys.

The alkali universally employed by the bleachers in Great Britain is Russian or American potash, which contains about two-thirds of its weight of caustic potash, according to the experiments of Vauquelin (*Annales de Chimie*, XL. 273). The other ingredients are sulphate of potash, muriate of potash, carbonic acid, and siliceous earth. It has been alleged that the potash of commerce is often adulterated artificially with common salt. This the bleacher should always ascertain before employing it. Indeed, every bleacher, who wishes to be exact, ought to be in possession of a mode of determining the exact quantity of potash which the alkali that he intends to use contains. There are two methods which may be employed for this purpose. The first is to dissolve a certain quantity of the potash in water, and to try how much acid of a known strength is requisite to saturate the alkali contained in this solution. Ample directions for reducing this method to practice, are contained in the dissertation of Vauquelin above referred to. The second mode of testing the alkali is more rapid; but would be less convenient for the bleacher, unless he were in possession of a mercurial pneumatic trough; but if he is supplied with this part of chemical apparatus, the method is very easy; and, perhaps, in the hands of persons not very conversant with chemical experiments, more to be depended on than the first described method. It is this. A glass tube of the capacity of 10 or 12 cubic inches, shut at one end, and flat at the other, so as to stand on the mercurial trough when filled with mercury, is to be graduated into cubic inches and tenths. The tube, when the strength of the alkali is to be tried, is to be filled with mercury, and placed inverted on the trough. Then let up 20 grains of the alkali to be examined, which will rise to the top of the tube. Add now about 50 grains of sulphuric acid. As soon as the acid comes in contact with the potash, an effervescence takes place, and the carbonic acid is extricated. Observe the number of cubic inches and tenths of this gas extricated, taking care to sink the tube so far in the trough that the mercury in the tube and trough are upon the same level. Multiply the bulk of the carbonic acid by the number 0.46318; the product is the weight of carbonic acid present in grains. Multiply this weight by 2.18; the product is the weight in grains of real potash contained in 20 grains of the pearl ashes under examination.

Bleaching. This last method is founded upon several chemical facts which have been sufficiently established. The potash, as it exists in American or Russian potash, is combined with carbonic acid in such a proportion, that one atom of acid is combined with one atom of alkali. An atom of carbonic acid weighs 2.750, and an atom of potash 6. The weight of a cubic inch of carbonic acid gas is 0.46313 grains. Hence, if we multiply the bulk of carbonic acid in cubic inches and tenths, by 0.46313, we obtain its weight in grains. The numbers 2.750 and 6, are very nearly to each other as 1 to 2.18. Hence, if we multiply the weight of carbonic acid, found by 2.18, we obtain the weight of potash with which it was combined. It is proper to know, that this method will give the proportion of potash rather below the truth, because, a little of the carbonic acid will be held in solution by the acid employed. If we add such a quantity of sulphuric acid, that, after the expulsion of the gas, the whole shall remain in a liquid state, the result will be almost perfectly exact, if the bulk of the liquid be added to that of the gaseous product, and the whole be considered as carbonic acid gas.

Formerly, the Irish bleachers were in the habit of using barilla instead of potash. But there are two objections to the use of this alkali. In the first place, the weight of real alkali contained in the same proportion of barilla, is much smaller than in pearl-ash; and, in the second place, the weight of an atom of soda being greater than that of an atom of potash, it is probable, that the second will go farther in bleaching than the former. When to this fact we add the difference of the price, which is always in favour of potash, there can be no hesitation in affirming, that no bleacher who studies the principles of economy, would make use of barilla if he can be supplied with pearl-ash. In trying the strength of barilla, the second of the two methods above described cannot be employed, because barilla contains both carbonate of lime and carbonate of magnesia. Hence the quantity of carbonic acid will always be much greater than it would be, if barilla contained only carbonate of soda. According to the experiments of Kirwan, a great proportion of the soda in barilla is in a caustic state. But if we attend to the way in which this substance is procured by burning the *salcola vermiculata*, we shall scarcely be induced to adopt this opinion. For, during the combustion of vegetable substances, carbonic acid is always evolved in considerable quantities, this acid would, of course, combine with the alkali, and the heat of the combustion is insufficient to decompose the carbonate of soda when once formed.

Two methods of applying pearl-ash to the purposes of bleaching, are generally followed. These methods are called *Boiling* and *Bucking*.

Boiling needs no description. The alkaline ley and the goods are put together into a boiler, and the whole kept at the boiling temperature for the requisite length of time.

Bucking is somewhat more complicated. It consists in making the alkaline ley, raised to a boiling heat, to pass repeatedly through the goods. Various modes of performing this process are followed in

VOL. II. PART II.

different bleaching-houses. But they may be all reduced to one or other of the following three: 1. The goods are placed loosely in a proper vessel, the heated ley is made to run upon them, and to pass through them. As it comes to the bottom of the vessel containing the goods, it is pumped back again into the boiler, where it is heated a second time, and then made to pass through the goods as before. This process is repeated as often as is thought requisite. 2. The alkaline solution is put into the bottom of a large boiler, having a platform of wood, with holes through it, placed a little way above the surface of the ley. Through the middle of this platform there passes a pipe of a convenient size, the lower end of which reaches nearly to the bottom of the boiler, being immersed deep in the ley, while the upper end rises as high as the mouth of the boiler. The goods are placed upon the platform, and round the tube within the boiler to a convenient height. When heat is applied to the boiler, the steam generated is prevented from making its escape by the wooden platform and the goods. It, therefore, acts upon the surface of the ley, and forces it to ascend through the tube. A kind of umbrella is suspended over the top of the tube, which assists in spreading the ley over the surface of the goods. By this contrivance, it is made to spread over and trickle down through the goods, till it gets again to the bottom of the boiler, to be heated and forced up by the steam as formerly. This method is more efficacious than simple boiling, because the temperature of the ley is heated some degrees higher than 212° , which has a considerable effect upon the goods.

The following are sections of the vessels used for these two different methods of bucking: This figure shows the vessels employed, when the ley is simply pumped back into the boiler. A is the boiler

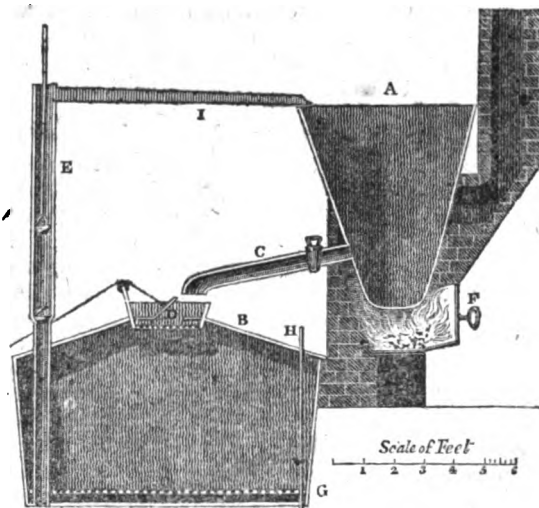

for heating the alkaline ley. B is the large wooden vessel in which the goods are placed. C the cock and pipe, by means of which the ley is conveyed upon the goods. D a square box designed for spreading the ley over the goods within the vessel B. E the pump for raising the liquor again out of the vessel B, from which it is conveyed by the

T t

Bleaching. spout I back again into the boiler. F is the furnace for heating the ley. G represents the false bottom of the wooden vessel, full of holes, for the passage of the ley when it has run through the goods. H is a round wooden staff, which completely fits a hole at the bottom of the bucking vessel. It is called a duck, and is intended to be pulled up whenever the spent alkaline liquor is to be run off.

This figure represents the second kind of bucking apparatus. A is a metallic boiler to be fixed in brick work, as in the preceding figure. BB is the top part of wood, called a crib, with the bottom full of holes. In this, the goods are placed one above another, often amounting to many hundred pieces at one operation. C is the pipe through which the leys boil up, and dd is the umbrella suspended over the pipe, for the purpose of spreading the ley more effectually over the goods.

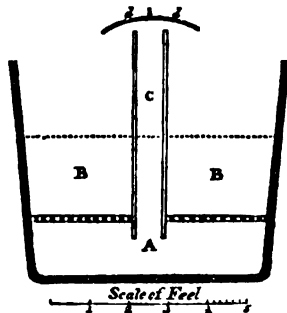

The third method of bucking is a modification of the second. It is considered as preferable, and is perhaps most generally used by experienced and extensive bleachers. The platform and its ascending pipe are placed, not in the boiler, but in a convenient tub or cistern. The requisite quantity of ley is put into the cistern below the platform. A tube passes into it, which conveys steam from a steam-boiler, in such quantity as first to heat up the ley to the boiling point, and then to force it up through the central tube, to be deposited over the surface of the goods, and to filter through them into the space below the platform. This method of bucking so nearly resembles the last, that the nature of the vessel employed will be easily understood without a figure.

The quantity of pearl-ash required for bleaching linen in general, amounts to $\frac{1}{10}$ th or $\frac{1}{12}$ th of the weight of the goods to be bleached. This quantity, however, is not to be used all at once; but is to be divided into six or eight portions, to be employed each in as many bucking processes. When the goods are boiled in an alkaline ley, the boiling is usually continued for four or six hours. In bucking, the process is generally continued till the liquor is so far evaporated, that the whole of it which remains is retained by the goods themselves. This generally requires from six to eight hours.

Heavy yarns for making ducks and similar fabrics are most advantageously bleached before being woven into cloth. These yarns are usually boiled with from 16 to 20 per cent. of their weight of pearl-ash, divided among two, three, and sometimes four boils, in proportion to the nature of the fabric, and the degree of whiteness required. When two boils are required, $\frac{1}{3}$ th of the weight of the goods may be used in the first, and $\frac{1}{6}$ th in the second boil. If the goods are difficult to bleach, or if a greater degree of whiteness be required, it is sometimes customary

to give them a third, or even a fourth boil, diminishing the allowance of potash each time. In the last boil, one-third or one-half of the potash is frequently kept out, and its place supplied by an equal quantity of soft soap. When the weather is favourable, the goods are sometimes exposed on the grass after each boiling.

3. The third process is to expose the goods to the action of oxymuriatic acid in some one of the three states described in a preceding part of this article,—namely, dissolved in water, combined with lime in the state of liquid oxymuriate of lime, or in the state of solid oxymuriate of lime. The first of these states is the most economical; but its very noxious odour renders its application scarcely practicable on a great scale. The second state consists of two atoms of oxymuriatic acid, combined with one atom of lime, or it is a bichloride of lime; and the third state, or the dry powder, is a compound of one atom of oxymuriatic acid and one atom of lime, or it is a chloride of lime. Of these two last substances there can be little doubt that the first, or the one made in the liquid way, is the most efficacious. But we shall suppose the dry chloride of lime to be the substance used; as its employment is likely to increase very much, especially among those bleachers who are the most likely to require instructions. Besides, it is not difficult to apply the observations made on chloride of lime to the liquid bichloride.

The quantity of oxymuriate of lime required for bleaching linen varies considerably, according to the nature of the linen operated upon,—according to the season of the year, and the degree of exposure on the grass,—and according to the whiteness required. But we may state the average quantity as varying between $\frac{1}{12}$ th and $\frac{1}{10}$ th of the weight of the goods employed. This quantity may be divided into three or four processes. If three processes be reckoned sufficient, $\frac{1}{2}$ ths of the oxymuriate may be expended on the first operation, $\frac{1}{3}$ ths in the second, and $\frac{1}{6}$ ths in the third. If four processes are considered as requisite, then $\frac{1}{4}$ ths of the oxymuriate should be used in the first operation, $\frac{1}{4}$ ths in the second, $\frac{1}{8}$ ths in the third, and $\frac{1}{8}$ ths in the fourth. Two wine pipes may be employed for the solution of the bleaching powder. They should be placed on one end, the other end being open; and a plug-hole should be made in each, about 10 or 12 inches above the bottom. From 20 lbs. to 100 lbs. of the bleaching powder is to be put into a small tub or bucket, where it is to be well bruised and mixed with a little water. This mixture is to be thrown into one of the wine pipes, more water is to be added, and the whole carefully stirred together for a few minutes. A cover is then to be put upon the pipe, and the whole is allowed to stand till the insoluble part of the powder, consisting of quicklime, subsides below the plug-hole. The clear solution, called *stock-liquor*, is now to be drawn off through the plug-hole, and may either be used immediately, which is most expedient, or it may be kept under a close cover till wanted.

Repeated portions of powder may, in this manner, be dissolved in the same pipe, till the sediment ac-

Bleaching. cumulate to the height of the plug-hole. When this happens, fresh stock-liquor must be prepared in the other pipe. But instead of using pure water, as in the first operation, the sediment in the first pipe should be repeatedly washed, by filling up the pipe with water,—stirring the sediment well,—allowing it to settle, and then drawing off the clear liquor by the plug-hole. These washings, as long as they show any bleaching power, are to be used in the second pipe, instead of pure water, for preparing stock-liquor. The sediment, in every future operation, should be exhausted in a similar manner.

The strength of this liquor is determined by means of the graduated glass tube, figured in the margin, which is known by the name of the *Test-tube*. The method is as follows: One part of the best indigo is dissolved in nine parts of strong sulphuric acid, and the solution is mixed with 990 parts of water, making a solution, $\frac{1}{1000}$ th part of which is indigo. Of this liquid a quantity is to be poured into the test-tube, so as to fill it up to 0, or the commencement of the scale. The bleaching liquor, whose power is to be tried, is then to be dropt gradually in and mixed with the blue liquor, by shaking the tube from time to time, till the blue is changed into a clear brown. As soon as this takes place, the degree of the scale to which the mixture reaches is observed, and the figure marked at that degree indicates the strength of the steep-liquor. The lowest on the scale is, of course, the strongest in bleaching power, being capable of destroying most colour. The liquor, whose strength is thus ascertained, is denominated Steep-liquor, of 1, 2, 3, 4, 5, and 6 degrees; the last of which is the weakest ever used for any kind of goods. By adding stock-liquor, when the steep-liquor is too weak, and water when too strong, this liquor may be obtained of any strength which is required.

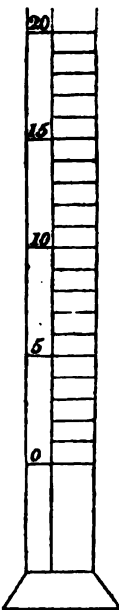

The bleacher's operations should go on in regular rotation. The whitest goods are put into the clean fresh steeps. As these goods do not exhaust the bleaching power of the liquor, its strength is restored after they are taken out, by the addition of fresh stock-liquor. It is then used for goods in a less advanced state of whiteness. If the second operation has not exhausted its bleaching powers, or rendered it foul, it may be used a third time by another addition of stock-liquor. But if it has been rendered very foul, and indicates only 12 or 15 degrees in the test-tube, it is not worth preserving or using.

One pound of the bleaching powder, as it is prepared by Mr Tennant and Company of Glasgow, is capable of forming from ten to twelve gallons of liquor of one degree.

The exposure of the goods to the action of the oxymuriate of lime should not commence till after the third boil or buck, if they are to be exposed three times to the action of this substance; and after the second, if they are to be exposed to four ope-

Bleaching. rations, with muriate of lime. These operations should alternate with the last bucks or boils. In all cases, the oxymuriate of lime must be dissolved in such a proportion of water as to allow the goods immersed in it to float loosely and easily in the solution, that the liquid may come into free contact with every part of them.

Though the method of immersion or steeping the goods in the solution of oxymuriate of lime is most generally used, yet, in some cases, great advantage is obtained by *wincing* the goods through the solution, instead of allowing them to rest for any length of time in it. When the method of wincing is followed, a solution of twice or thrice the ordinary strength may be safely used, and much time in consequence saved. When the goods are coarse and heavy, such as yarn for ducks, this last method is almost universally preferred. These heavy yarns require from $\frac{1}{12}$ th to $\frac{1}{15}$ th of their weight of oxymuriate of lime, divided into a number of operations corresponding to that of the boils, and following these boils, or these boils with exposure on the grass, when such exposures are employed. In the first oxymuriatic operation, they are winced through a strong solution, produced by adding about three or four ounces of dry oxymuriate of lime to each gallon of water. The yarns are hung over a roller fixed in the mouth of the trough or tub that contains the solution, which covers part of its surface. This roller being then turned rapidly round by means of a crank fixed on one of its ends, the yarn is made to pass rapidly and repeatedly through the liquor for the space of thirty or forty minutes. Fresh parcels of yarn are, in succession, passed through the liquor, its strength being restored by additions of oxymuriate when necessary, and the whole changed when exhausted of bleaching powers and foul. In this way, a very powerful bleaching effect is produced, and yarns which have undergone one process in this way, may receive the remaining oxymuriatic processes to which they are to be exposed in the ordinary way of immersion, which is less expensive in point of labour, though less efficacious.

The oxymuriatic process then is repeated three or four times, beginning after the second or third boil or buck, and alternating with every subsequent boil or buck. The time during which the goods are exposed to the oxymuriatic solution during each process, is from six to twelve hours.

4. The fourth process consists in steeping the goods in an acid solution. This is called the acid process. We have already observed, that the acid at first used for this purpose was sour milk; but that, when Dr Roebuck contrived his new method of preparing sulphuric acid, Dr Home proposed this acid as a substitute for sour milk; that it speedily came into general use, and very much improved and shortened the tedious bleaching processes at that time in general use. This steeping in sulphuric acid is repeated twice, and sometimes thrice, once after each of the last two or three immersions in the oxymuriate of lime. For this purpose, a quantity of strong sulphuric acid is taken, amounting to about $\frac{1}{10}$ th or $\frac{1}{15}$ th of the weight of the goods to be immersed. This acid is diluted with 60 or 80 times its weight

Bleaching of water, which reduces it to the specific gravity of about 1.015. Now, sulphuric acid of this specific gravity contains about $1\frac{1}{2}$ per cent. of its weight of real sulphuric acid. In this liquid they are steeped from eight to twelve hours. When linen fabrics are intended for printing, they require two or three additional processes in alkali, and one in acid, and the solution of the sulphuric acid is generally made one-third stronger when the goods are intended for the madder copper.

Such are the different processes at present followed by the practical bleachers in Great Britain. After each of them, whether boiling or bucking in an alkaline solution, immersion in oxymuriate of lime, or steeping in sulphuric acid, the goods must be carefully washed in pure water, either by machinery or otherwise, till all the materials employed are completely washed out of them. Upon this much of the economy and success of bleaching depends. It is likewise of great advantage to free the goods from the water which they contain after each washing, before subjecting them to the next operation. For this purpose, Bramah's press is employed in almost all the large bleaching-houses, and constitutes one of the greatest improvements introduced of late years.

2. Bleaching of Cottons.

Cotton is a kind of down which fills the seed pods of various species of plants, particularly the *Gossypium herbaceum*, *hirsutum*, and *arboreum*, from all of which it is extracted in considerable quantity for the purposes of manufacturers. This substance was known to the ancients, and made by them into thread and cloth. Cotton cloth appears to have been generally worn in Egypt and the neighbouring countries at a very early period; and no doubt the plant was cultivated in India and China for similar purposes before the time at which the history of these nations, as far as we are acquainted with it, commences. Pliny gives a short description of the *gossypium* which grew in Upper Egypt, which is sufficient to show us that it was the same with our cotton plant. "Superior pars Ægypti in Arabiam vergens gignit fruticem, quem aliqui *gossipion* vocant, plures *xylon*, et ideo lina inde facta *xylina*. Parvus est, similemque barbatae nucis defert fructum, cujus ex interiore bombyce lanugo netur. Nec ulla sunt eis in candore mollitiave preferenda." (*Plinii, Natur. Hist. Lib. xix. c. 2.*) The *byssus* mentioned in the same chapter was probably likewise a species of cotton; though the account of it given by Pliny is not sufficiently precise to enable us to make out the point with certainty.

Since the discovery and colonization of America and the West Indies, and our great connection with East India, cotton has become a very common article of clothing in Europe. The manufacture of cotton cloth in consequence has increased prodigiously, and in Great Britain constitutes one of the great branches of manufacturing industry. As it does not go through the complicated processes of flax and hemp, and is naturally (for the most part at least) of a lighter colour, the art of bleaching it is much more

easy and less expensive. The processes are nearly the same as those for linen; but it will be requisite to go over them shortly, in order to point out the difference in the proportions of the ingredients employed, and some other little circumstances which ought to be generally known.

1. The first, or fermenting process, is the same for cottons as for linens. This must be the case, because the weaver's dressing, which it is the object of the process to remove, is the same in both cases.

2. But there is a difference in the second process, which consists in exposing the goods to the action of alkaline leys.

Cotton goods are generally exposed to the action of lime diffused through water, so as to constitute what is called *milk of lime*. The liquid is heated to the temperature of 200° , and the cloth is kept in it from four to six hours. Two or three alkaline processes will be required after this, and the quantity of potash which ought to be used should amount to $\frac{1}{10}$ th of the weight of the goods. When the application is to be made at twice, the first of the operations should have $\frac{2}{5}$ ths, and the second $\frac{3}{5}$ ths of the whole potash. If three processes are to be gone through, the first and second should have $\frac{2}{5}$ ths each, and the third $\frac{1}{5}$ th of the potash.

When heavy cottons are bleached, either boiling or bucking may be employed, as described under the head of linens. When the cotton fabrics are light, or contain dyed colours, boiling is generally preferred, and the proportion of alkali diminished one-third, while a quantity of hard or soft soap, equal to the diminution of the alkali, is added to the ley.

3. The third, or oxymuriatic process, is nearly the same for cottons as for linens. The quantity of oxymuriate of lime used, should amount to $\frac{1}{30}$ th or $\frac{1}{40}$ th of the weight of the cotton cloth to be bleached. This quantity is divided among two or three operations, an oxymuriatic process following each alkaline process. When three operations are to be performed, the first must have $\frac{1}{2}$ ths, the second $\frac{1}{3}$ ths, and the third $\frac{1}{6}$ th of the whole oxymuriate of lime. When only two operations are to be performed, the first should contain two-thirds, and the last one-third of the whole. The duration of each steep should be from six to twelve hours, but not longer. If wincing through the solution be preferred, a stronger liquor may be used, and the operation may be finished in fifteen or twenty minutes.

4. The fourth, or acid process, is pretty much the same for cottons as for linens; the quantity of sulphuric acid should amount to about $\frac{1}{60}$ th or $\frac{1}{80}$ th of the weight of the cotton goods. It must be diluted with water till its specific gravity be reduced to 1.010. A steep in this diluted acid from six to twelve hours after each of the two last oxymuriatic processes is generally made use of.

When the fabrics are very light, or contain dyed colours, the souring is only once used, and the strength of the acid is reduced to 1.008. This souring is applied after the last oxymuriatic process. In this case thorough washing or rinsing in water, is most strictly to be attended to before exposure to the sulphuric acid in souring. When cotton fabrics

Bleaching. are intended for printing with madder colours, they require one or two additional bucks or boils, and the sours should be one-third stronger.

The intermediate washings in pure water, and the proper draining of the goods after washing, must be observed with as much care in bleaching cotton as in bleaching linen. It is only in the bleaching of those goods intended for printing, that any exposure to the light and air is now used, and that but seldom even in this case.

3. Bleaching of Rags for the Papermaker.

The rags to be whitened should be well washed in the engine, and when reduced to what is called half-stuff, the water should be run off, leaving just enough to allow them to be easily turned. While the rags are thus preparing, a solution of the bleaching-powder is to be got ready, by putting the powder into a pitcher or other convenient vessel, and pouring upon it two or three gallons of water, stirring and bruising it well, till every thing soluble is taken up. After it has stood some time to allow the insoluble sediment to fall down, it is fit for use, and the pure solution should be poured into the engine. The sediment may be repeatedly washed with fresh portions of water to exhaust any remains of soluble matter, which alone is useful in the whitening process. While this last operation is going on, the engine is to be kept moving, and to continue so for about an hour, which will generally be sufficient to produce the requisite degree of whiteness. The water may now be returned upon the engine, and the washing continued as usual till the process be completed. The quantity of powder usually allowed, is from two pounds to four pounds for every hundred weight of rags, in proportion to the whiteness required, and the difficulty of whitening the stuff.

Rags containing dyed colours, to be discharged, should be well washed and reduced to half-stuff. They are then removed from the engine and put into a puncheon, made water tight, but having a sufficient opening in the side to admit with ease the putting in and taking out of the stuff, and capable of being shut up so as to retain the water. Having put the stuff into this puncheon, take for every cwt. of the rags a solution containing from five to eight pounds of bleaching powder, according to the strength and fixedness of the colours to be discharged. Pour the solution into the puncheon among the stuff, allowing liquid enough to let the stuff float easily, and for each pound of powder used, add half a pound of sulphuric acid. Then shut up and secure the opening so as to make the puncheon air tight; then turn the puncheon round upon its axis, by means of a crank fixed at one end of it. Moving it in this manner gives facility and uniformity to the discharging process.

We have now finished the sketch which we proposed to give of the processes at present followed by the practical bleachers of Great Britain. For several

other applications of the same operations, we refer to the article BLEACHING in the *Encyclopædia*. But probably a few words will be expected from us on the theory of the art. Upon this subject, the following observations are all we have to offer:

The fibres of hemp, linen, and cotton, are naturally white; but, before bleaching, they are combined with a substance which gives them their grey or brown colour. The object of bleaching is to remove this substance. From the experiments which have been made upon the subject, it would appear that this substance is partly in the state of resin, and partly in a state analogous to that of the volatile oils. Resins dissolve readily in the alkalies, which they neutralize and convert into a species of soap. But this is not the case with the colouring matter, which is in a state analogous to that of volatile oil. After the weaver's dressing has been removed, the cloth is boiled or bucked repeatedly in alkaline leys, which dissolve and separate the whole of the colouring matter, which possesses the characters of resin. The alkaline ley, after this process, is turbid, has a brownish red colour, a strong smell, and has lost its alkaline properties. When muriatic acid is poured into it, a copious flocky precipitate subsides, consisting of the colouring matter. This substance, when properlyedulcorated, has a greenish grey colour, which it retains when separated from the water by the filter. But, when dry, it becomes blackish externally, though it retains internally its greenish tint. It is soluble in alcohol, insoluble in oil of turpentine, but dissolves readily in the alkalies. It tinges the strong acids, but does not readily dissolve in them. When thrown upon a red-hot iron, it burns with a yellow flame and a black smoke, leaving a charry residuum. These properties, for the knowledge of which we are indebted to Mr Kirwan,* are sufficient to show us that the substance which the alkalies separate from linen is analogous to the resins.

By repeated boiling in alkaline leys the cloth is rendered whiter. But it is not yet bleached; because a colouring matter still remains, which the alkalies are incapable of dissolving. The action of oxymuriatic acid, or exposure to the air and light, produces a change on this colouring matter, and renders it capable of being dissolved in alkalies. In short, by these processes it is converted into a resinous matter, similar to that which the alkalies had previously removed. There can be no doubt that this change is produced by the union of the colouring matter with oxygen. When the oxymuriatic acid is used, the oxygen is supplied by the water which is decomposed by the mutual action of the chlorine and the colouring matter. The chlorine combines with the hydrogen of the water, and is converted into muriatic acid; while the colouring matter combines with the oxygen of the water, and is converted into resin.

It would appear, that this change in the colouring matter renders it white; for linen will appear bleach-

* See his *Experiments on the Colouring Matter of Linen Yarn and its Solvents*, in the *Transactions of the Royal Irish Academy* for 1789.

Bleaching Blockade. ed if it be treated with a sufficient quantity of oxymuriate of lime. But this state of the colouring matter is not permanent. If it be allowed to remain in the cloth it speedily becomes yellow. Hence the reason why cloth, bleached with oxymuriatic acid alone, soon loses its white colour again. This happened to Berthollet, in his first trials to bleach in the large way, by means of oxymuriatic acid. It happened likewise, at first, to several bleachers in this country. It is requisite, that the colouring matter, now become soluble, should be removed by alkalies. Hence we conceive, contrary to the practice of bleachers, that the last process ought always to be boiling in an alkaline ley. In great towns, as in London, where linen cannot be exposed to the air and sun upon the grass, it would be a great advantage, if it were steeped, for some time before it is washed, in a solution of oxymuriate of lime. It might then be boiled in an alkaline ley. Linen or cotton, thus treated, would not become yellow by age, as is too often the case with linens in large towns.

The precise use of the steeping of the goods in sulphuric acid has not been ascertained; though it is known to be indispensable. It is supposed, that both linen and cotton contain a portion of iron, and that the acid removes this substance, which both renders the colour whiter and the cloth fitter for the subsequent processes of dyeing and calico-printing.

Bleaching Blockade. This explanation is not improbable, though we are not aware of any accurate experiments, by means of which, the presence of iron in the sulphuric acid solution, employed as a souring, has been ascertained. But, probably, the great use of the acid is to remove or neutralize the alkali, which, if allowed to remain in the cloth, would gradually injure its texture.

We have taken no notice, in the preceding article, of a proposal, made a good many years ago in Ireland, and, in support of which, a pamphlet was published by Mr Higgins of Dublin; we mean the substitution of the hydrogureted sulphuret of lime for the alkali. The reason of this omission is, that we are not in possession of any facts on the subject. But we consider the circumstance of no British bleacher having introduced this substitute into his work, as sufficient to entitle us to infer, that the substitute would not answer the purposes for which it was recommended. Several objections to its use will readily present themselves to those who consider the subject. Among others, we may mention, that if any metallic substance, as iron, were to come in contact with the goods which are under the influence of hydrogureted sulphuret of lime, this last substance would act as a mordant, and fix the metal on the cloth; from which it could not be again removed without some expence, and without the risk of injuring the strength of the substance. (J.)

Definition. BLOCKADE, in war, the shutting up of any place or port by a naval or military force, so as to cut off all communication with those who are without the hostile line.

There is, perhaps, no part of the law of nations which, in practice, presents so many perplexing questions, as that which concerns the respective rights of neutral and belligerent states. No definite line of distinction has yet been drawn between the privileges of war and peace; and the consequence has been, that, in all the wars which have been waged in Europe, the general tranquillity of the world has been endangered by the jarring of these two different interests. It has commonly happened, too, that all these important questions have been agitated during a season of war, when the passions of the contending parties were keenly engaged in the dispute,—when principles were already subverted,—and when the minds of men, exasperated by the glaring infraction of acknowledged rights, were not in a state to agree on any system of general equity, by which to regulate and reform the erring policy of states. In these circumstances, many points of international law, which appear to rest on the most obvious principles, and which are very clearly settled in the writings of civilians, have, nevertheless, been the occasion, in practice, of no small controversy, and have frequently involved nations in all the miseries of protracted war. This has been, in some measure, manifested in the case of the *Rights of Blockade*; respecting which, though no difference of opinion has ever prevailed among speculative

writers, a controversy arose during the late contests in Europe, which, along with other points, ultimately involved Great Britain in a war with the neutral powers. We propose, in the course of the subsequent observations, to state, 1st, The general principles from which the most approved writers have deduced the rights of blockade; and, 2d, To give a short account of the recent differences which have taken place between the neutral and the belligerent states, respecting the extent of those rights.

In regulating the respective privileges of the neutral and the belligerent, it has been generally held as a fundamental principle, by writers on the law of nations, that those rights, from the exercise of which less benefit would accrue to the one party than detriment to the other, should be abandoned; and in all cases where the rights of peace and the rights of war happen to come into collision, the application of this rule will decide which of the two parties must yield to the convenience of the other. Thus the neutral state is debarred from carrying on any trade with either of the belligerents in warlike stores. The general right to a free trade is modified, in this particular instance, by the paramount rights of the belligerent. To refrain, for a time, from trading with an individual state in warlike stores, can, at most, only impose a trifling inconvenience on the neutral power, while the continuance of such a trade might terminate in the destruction of the belligerent. The detriment occasioned to the one party, by the existence of such a trade, is;

Blockade. in this manner, infinitely greater than the loss suffered by the other from its abandonment. Warlike stores, and whatever else bears a direct reference to war, are, accordingly, proscribed as unlawful articles of trade, and made liable to seizure by either of the belligerents. To this inconvenience the neutral is exposed, to avoid the greater inconvenience and damage which might fall on the belligerent, by the licensing of such a trade. On the other hand, the neutral state enjoys the most unlimited freedom of trade in all other articles, with either of the powers at war; and though, by means of this beneficial intercourse, they may be both furnished with the means of carrying on a protracted contest, this is a contingent and incidental consequence of the trade, which, in its character, is substantially pacific, and which is attended with such great and immediate advantages, that they could not, with any regard to equity, be sacrificed to the remote convenience of the belligerent.

Applying these principles to a siege or to a blockade, it is evident, that the belligerent who had an expensive scheme of hostile operations of either kind in dependence, would be far more seriously injured by its interruption, than the neutral would be benefited by a free intercourse with the blockaded place. On this ground, therefore, a belligerent who has formed a siege or a blockade, has an indisputable right to debar the neutral from all intercourse with those who are included within his lines; and any attempt to penetrate the blockade for the purposes of trade, subjects those who attempt it to destruction, and their properties to confiscation. The very existence, indeed, of a siege or a blockade, as a lawful act of hostility, implies the right of enforcing it by an indiscriminate exclusion of all who seek access to the besieged.

But though this view of the nature of a blockade, and of the rights attaching to it, is clearly laid down by all writers on the law of nations, and though it has been acknowledged, in practice, by all civilized states, a question has been agitated in the late wars of Europe, between the neutral and the belligerent powers, as to the *degree* of restraint necessary to constitute a blockade, and, of course, to entitle the blockading party to all the rights consequent upon this scheme of operations; and it is this dispute which was, in a great measure, the occasion of a general war with the neutral powers.

The unexampled success which attended the naval operations of Great Britain, during her late wars with France, naturally suggested to her rulers the possibility of extending this species of annoyance, and of converting the all-powerful navy which they possessed, into an instrument of active hostility. With this view, in place of confining its efforts to the mere watching of the enemy's already ruined trade, it was resolved to give greater scope to such an immense engine of maritime power, by placing under blockade the enemy's ports,—the mouths of navigable rivers,—and even extensive tracts of his coast. Proclamations to this effect were, accordingly, issued,—the neutral trader was duly warned off, and prohibited, under the peril of detention, from

all intercourse with the interdicted coast. But the legality of these blockades by proclamation being disputed, both by the neutral powers and by the enemy, their execution was resisted by a counter-decree, which, on the plea of retaliation, placed under blockade the whole island of Great Britain, and subjected all neutral vessels to detention and capture, which should have been found touching at any of its ports. On the same plea of retaliation, several decrees, or Orders in Council, were issued by Britain, ordaining, that no neutral vessel should have any intercourse with France and her dependencies, except such vessel should first touch at a British port, where, in some cases, the cargo was to be landed, and was to pay certain duties to the British government. From this period the maxims of equity, and the rules of international law, were set aside, and the ocean became a scene of proscription and pillage. All this anarchy originating in a disagreement respecting the nature and extent of a blockade or siege, it becomes of importance to settle this important question.

The object of a blockade is to reduce the inhabitants of the blockaded town to such straits, that they shall be forced to surrender to the discretion of their enemies in order to preserve their lives; and the legality of every blockade, except with a view to capture, has been questioned. But without entering into this question, it seems obvious, that, in order to constitute the blockade of a town, either with a view to capture, or to temporary annoyance, the line by which it is surrounded should be so complete, as entirely to obstruct all access into the place. When a place is blockaded, with a view to capture, the task of maintaining a real blockade may be safely left to the blockading party. But when a port is blockaded, with a view to mere maritime annoyance, the case is widely different; because, in these circumstances, the belligerent will equally attain his end by maintaining the mere show of a blockade, while he is in possession of all its substantial rights. He may, to save himself expence and trouble, relax the blockade of his enemy's ports, while he enforces the exclusion of all neutrals, as rigorously as if he were maintaining an effectual blockade: and, in this case, his proclamations, while they are issued ostensibly for the blockade of the enemies' ports, would, in reality, amount to edicts for the suppression of the neutral trade. The urgent, immediate and obvious interests of the neutral would here be sacrificed to the remote, and in many cases, imaginary, convenience of the belligerent. The edict might be issued for the blockade of the enemies' ports, or for extensive tracts of his coast, round which no hostile line can ever be drawn so as to constitute a real blockade, and the whole trade of the neutral, with those interdicted parts of the enemies' territory, must be immediately given up at the arbitrary mandate of one of the belligerents. The neutral trade,—in place of being regarded as a matter of right,—in place of being regarded as a common benefit to the civilized world, and on this account to be cherished and encouraged, would, under such a system be looked upon in the light of a tolerated evil.

Blockade.

Principles according to which these rights ought to be exercised.

Questions arising from these rights.

Blockade
Bloch.

existing only by the sufferance of those who imagined they had an interest in obstructing and in crushing it. The law of nations is not a partial system, modelled to suit the convenience of one party. It is a system of general equity, and its edicts are founded on a comprehensive view of what is for the common advantage of all. In this view, then, the consequences to the neutral of those extensive and nominal blockades are sufficient to constitute them illegal. The damage to the neutral is infinitely greater than the benefit to the belligerent. The rights of blockade, and the limitation of those rights, must stand upon the same principle of justice and of public law; and their extension beyond this equitable principle, must terminate in universal confusion and anarchy.

In opposition to those arguments in favour of the neutral powers, it has been urged, that the new system of naval annoyance, introduced by Great Britain in 1806, was legal according to the strictest construction of the law of blockade, because the proclamations for interrupting all intercourse between the different parts of the French coast, were not issued until it was ascertained, by the most particular inquiries, that Great Britain possessed an effectual naval force to blockade the enemy's coast from Brest harbour to the mouth of the Elbe. It is solely upon this principle that the ministers of this country maintained the legality of those blockades, and any breach in the line of blockade, they admitted, would be sufficient to constitute them illegal. Such, then, is the present state of this important controversy, which seems to resolve itself into a mere question of fact, namely, whether the blockading power has actually carried into effect the blockade, of which notice by proclamation has been given to the neutral powers.

At the conclusion of the last treaty between Great Britain and America, no settlement took place of those disputed questions. The main war between the European belligerents, out of which the American dispute had incidentally sprung, being at an end, the controversy respecting rights, which could only be exercised in a state of war, had lost all practical importance. It had become a mere question of abstract right, the decision of which was wisely adjourned by the powers at war, and not suffered to clog the great work of a general peace. It is likely, however, that on the breaking out of any new war, this and other questions of a like nature would recur; and on this account it might be of importance to the future peace of the world, if, in the present interval of universal peace, while men's passions are at rest, these questions could be settled according to some acknowledged rule of equity or policy, and not left, in the case of another war, to the rude arbitration of force. (o.)

BLOCH (MARK ELEAZAR), an Ichthyologist and Helminthologist, born at Anspach, about the year 1730. He was of the Jewish nation, and his parents being indigent, his early education was much neglected; but, having entered into the employment of a surgeon at Hamburgh, he supplied the deficiency by his own exertions, and made great progress in the study of anatomy, as well as in the other departments of the medical sciences. He established

Bloch

himself as a physician at Berlin, and found means to collect there a valuable museum of the subjects of all the three kingdoms of nature, as well as an extensive library; and these objects often attracted to his house an assemblage of the most accomplished naturalists of his age and country.

He applied himself, however, more particularly to those parts of natural history which are the most connected with the practice of physic: and, on occasion of a prize question of the Academy of Copenhagen, he entered into a very elaborate examination of the different species of worms, which are found in the bodies of other animals. In his *Essay on this subject*, to which the prize was adjudged, he maintains, that the parasitical species are only found within the animal body; and since they often occur in the foetus, and in cavities which are completely inclosed, he infers that they must be generated in some unknown way, and not taken in with the food in the form of eggs. For the general remedy in cases of worms in the intestinal canal, he recommends large draughts of cold water, followed by cathartics. He has added to his *Essay* a complete classification and description of all the species of intestinal worms, accompanied by figures.

M. Bloch also published a variety of papers on different subjects of natural history, and of comparative anatomy and physiology, in the *Collections of the various Academies of Germany, Holland, and Russia*, particularly in that of the *Friendly Society of Naturalists at Berlin*. But his great work was his *Ichthyology*, which occupied the labour of a considerable portion of his life. His attention was first directed to the subject by receiving a present of a species of salmon, which he could not find described in the *Linnæan System of Nature*; and he discovered a number of similar omissions in *Artedi*, and in all former ichthyologists. He undertook to collect into one work every thing that was known respecting the natural history of fishes, and to give figures of all the species; and he passed several summers by the sea side, and among fishermen and their nets, comparing the descriptions of authors with nature, and taking bold sketches of the most interesting subjects, not uncommonly on board of the very boats which furnished them. His publication was encouraged by a large subscription, and it passed rapidly through five editions in German and in French. He made little or no alteration in the systematical arrangement of *Artedi* and *Linné*, although he was disposed to introduce some modifications into the classification, depending on the structure of the gills, especially on the presence or absence of a fifth gill, without a bony arch; a character which affords some useful subdivisions of several genera. To the number of genera before established, he found it necessary to add 19 new ones; and he described 176 new species, many of them inhabitants of the remotest parts of the ocean; and by the brilliancy of their colours, or the singularity of their forms, as much objects of popular admiration as of scientific curiosity.

In 1797, he paid a visit to Paris, where he was secure of finding a variety of collections of such subjects of natural history as had been inaccessible

Block
Machinery.

to him on the shores of the Baltic; and he returned to Berlin by way of Holland. His health, which had hitherto been unimpaired, began now to decline. He went to Carlsbad for its recovery, but his constitution was exhausted, and he died there the 6th of August 1799. (*Coquebert in Rapport de la Société Philomathique*, Vol. IV. 8vo, Par. 1800.) E. X.

BLOCK, an instrument or machine of wood, chiefly employed in the rigging and other parts of a ship, by means of which a facility is given to the hoisting up or lowering down the masts, yards, and sails, or to the moving of any great weight, as guns, anchors, bales, casks, &c. It is, in fact, a modification of the pulley, and the names may almost be considered as synonymous.

There is nothing in the appearance of a block which, to an unpractised eye, would seem to require any stretch of mental ingenuity or of manual dexterity to manufacture. It is a machine apparently so rude in its structure, and so simple in its contrivance, that the name was probably given to it from its general resemblance to a log of wood, as is obviously the case with a butcher's *block*, a barber's *block*, the *block* of the executioner, &c. Of the two constituent parts of a ship's block, the external *shell* and the internal *sheave*, every carpenter might make the one, and every turner the other; and yet, when blocks were made by the hand, it seldom happened that the several parts were adjusted to each other with sufficient accuracy, or that a strict uniformity was observed in the various sorts and sizes, without which they cannot be expected to work with that degree of ease and truth, which is so desirable, and even necessary in the important office they are designed to fulfil, in the rigging and other parts of a ship.

BLOCK-MACHINERY. To acquire a greater degree of accuracy and uniformity, as well as celerity in the making of blocks, Mr Walter Taylor of Southampton took out a patent in the year 1781, to secure to himself the benefit of some improvement he had made in the construction of the sheaves; he also shaped the shells, cut the timber, &c. by machinery, which was put in motion by water on the river Itchin, near Southampton, where he carried on so extensive a manufactory of blocks, as to be able to contract with the Commissioners of the Navy for nearly the whole supply of blocks and blockmakers' wares required for the use of the royal navy.

Mr Dunsterville of Plymouth had also a set of machines for making the principal parts of blocks, which was wrought by horses; his manufacture, however, of this article was not carried to any great extent; but the blocks made by this machinery, as well as those by Mr Taylor's, were said to be of a superior quality to those constructed by hand, though still deficient in many respects.

No objection, however, would probably have been made to the quality of the blocks furnished by Mr Taylor, and used in the navy. It would rather appear that the enormous quantity consumed in the course of a long protracted war first called the attention of the Admiralty or Navy Board to the possibility of some reduction being made in the expence of so indispensable and important an article in the naval service; and that it was not prudent to de-

pend entirely on a single contractor, whom accident or misfortune might disable from fulfilling his contract: A fire might destroy his wood-mills, in which case it would have been difficult to procure, in all England, an adequate supply of blocks for the navy.

On these considerations, it seems to have been the intention of government to introduce, among other improvements then carrying on in Portsmouth Dock-Yard, a set of machines for making blocks, at the new wood-mills erected in that yard in 1801. About this time, the improvements which had been introduced into private concerns were gradually finding their way into the great public establishments of the country. Still, however, an old maxim seemed to prevail, that government ought not to be its own manufacturer. This maxim, though perhaps generally just in political economy, is, we conceive, neither just nor wise when applied to those articles which are of the first necessity in the King's navy. Indeed, where the safety of so many thousand lives depends wholly, as is sometimes the case, on the strength of materials and goodness of workmanship, it is most desirable that the whole ship, and every part thereof, from the pin of a sheave to the sheet anchor, should be manufactured under the immediate superintendence of respectable officers in the King's service.

About this time, too, Mr Brunell, an ingenious mechanist from America, had completed a working model of certain machines for constructing, by an improved method, the shells and sheaves of blocks. This model was submitted to the inspection of the Lords Commissioners of the Admiralty, and by them referred to General Bentham, the Inspector-General of Naval Works, who represented that, as the making of blocks was one of the purposes for which a part of the force of the steam-engine, erecting at the wood-mills, was intended to be applied, he did not hesitate to recommend the new machine, as an invention which would enable the government to construct its own blocks with a greater degree of celerity and exactness than those which were then in use; and that it appeared to be well suited for manufacturing blocks of every description and size, with a degree of accuracy, uniformity, and cheapness, far beyond any of the methods hitherto practised. The adoption of Mr Brunell's machinery was the consequence of this opinion.

The advantages to be expected from blocks so made were stated by Mr Brunell to consist, first, in bringing the shape of the outside of the shell to certain determined dimensions, so that those of the same size should actually be so, and not differ from one another, either in the proportion of the mortices, or in the shape and dimensions of the outside. Secondly, in adding strength where it was wanted, by making the head and bottom more substantial, and less liable to split; and, thirdly, in leaving the wood between the two mortices thicker, so as to admit a sufficient bearing for the pins; all of which would be accomplished without requiring any dexterity on the part of the workman, but entirely by the operation of the machinery. The uniformity and exactness with which they were to be made, would be attended with another important advantage to the

Block-Machinery.

Block-Machinery.

public—the difficulty of counterfeiting them would act as a precaution against embezzlement. Another very considerable advantage would be derived from the employment of much waste wood in the dock-yard, usually sold for little or nothing, for firewood and other purposes.

The sheaves or shivers would, by this new machinery, be made so mathematically true, and so exact to each other in their thickness and diameters, that every rheave of any particular size would equally fit any shell of the size for which it was intended; and the inconvenience to which ordinary blocks are liable from the friction of the ropes against one or alternately both of the sides of the mortices, was intended to be removed, by placing a sheet of metal on the upper part of the mortice, bent to the proper shape by an engine adapted for the purpose. Brunell also proposed a new form for the *clue-line* and *clue-garnet* blocks so as to secure the sails from splitting, by preventing the points of the sails getting into the blocks, which has since been adopted and greatly approved of in the navy.

In the sheaves, instead of the double coak or cogue inserted in two halves, he substituted a mixed metal coak of a new and particular form, which will be described hereafter, of increased strength and durability. This coak was to be cast with a precision in moulds, and fitted by an engine with the greatest nicety; the pins or axes of the sheaves to be of wrought iron, case-hardened and coated with tin, which would preserve the iron from rust in the parts which are not kept free from it by friction; as it has been found by experience that, however tight the pin be forced into the shells, the water will insinuate itself and corrode the pin; when this is the case, the rust soon extends itself to the parts on which the sheave turns, and renders it unfit for use.

From the machines that were already completed for manufacturing blocks of certain dimensions, Mr Brunell was enabled to make a calculation of the saving as to the first cost compared with the contract prices, which would be effected by the adoption of his invention. It was as under:

	Blocks of 8 inch.		12 inch.		16 inch.		21 inch.	
	s.	d.	s.	d.	s.	d.	s.	d.
Brunell's prices,	1	8½	4	5	8	11½	18	1½
Contract prices,	2	3½	6	11½	13	6	27	0½
Saving in first cost,	0	6½	2	6½	4	6½	8	10½

These savings, if realized to the full extent, were probably not more important than the increased strength, durability, and facility of working, which have been gained by the adoption of the block-machinery.

Those parts of the machinery which Brunell had completed in London, under his patent, were transferred to Portsmouth, and, in the course of the year 1804, were in operation; but the increased number of machines, the improvements that suggested themselves to the ingenious inventor, the application of other machines for making dead-eyes, trucks, and all manner of block-maker's wares, besides circular and upright saws, lathes, engines for

turning pins, rivetting, polishing, &c. exercised his skill and ingenuity till the year 1808, when he considered the whole system to be complete in every part, and incapable, so far as he could judge, of further improvement. From that time to the present, the block-machinery has been in full and constant employment, without requiring the least alteration, and very little repair, beyond the unavoidable tear and wear of engines that are kept in almost constant motion; and, which is still more extraordinary, without requiring the aid of the inventor, though attended only by a few common workmen or labourers; but they are superintended by Mr Burr, the master of the wood-mills, who is considered as an able and ingenious machinist. The quantity of blocks of every description, manufactured by the machinery in Portsmouth wood-mills, is more than sufficient for the consumption of the whole navy and the Board of Ordnance, and if pushed to the utmost extent of the works, would also have been sufficient to supply a great part of the shipping employed in the transport service.

It may be a matter of some curiosity to know the results of this system of machinery. It is put in motion by a steam-engine of thirty-two horses' power, which, however, is applied to a great variety of other purposes at the same time, wholly independent of the block-machinery. It has been found by calculation, that four men with the machinery, as it now stands, can complete the shells of as many blocks as fifty men could do by the old method; and that six men will furnish as many sheaves as before required sixty; and that these ten men, in displacing the labour of one hundred and ten men, can with ease finish in one year from 130,000 to 140,000 blocks of different sorts and sizes, the total value of which cannot be less than L. 50,000; and this is stated to be the average number which has annually been made from the year 1808, to the conclusion of the war. This number is found to be fully sufficient for supplying the wear and tear of blocks, not only in the naval, but also in the ordnance department. The consumption, however, must depend on other circumstances besides the number of ships in commission, and will be greater or less according as ships have been employed on severe or easy service, in a good or bad climate, in fine or rough weather, &c. Nor will the number here stated appear to be enormous, when it is considered what a multitude of blocks are required for a thousand sail of ships, which, at one period of the war, were in commission at the same time. A ship of 74 guns, for instance, requires the following blocks for her equipment:

Single blocks from 5 to 26 inches,	No.	622
Double ditto from 7 to 26 ditto,	-	190
Various other blocks generally large, and several of them treble,	} 74	
For each of the 74 guns, 6 blocks,	-	444
Total,		1270
Besides dead-eyes, hearts, parrels, and puttock-plates, all manufactured at the mills,	} 160	
Of all kinds in a 74 gun ship,		1430

Block-Machinery.

Block-Machinery.

The average number of ships of the line in commission, appears to have been about 160; these would require 143,000; and allowing the remaining 900 ships and vessels to require only twice this number, there would be wanted for the first equipment of the 1000 ships of war, 429,000 blocks, which, at the ordinary rate of making them at the mills, would require three years in completing.

The different sorts and sizes of blocks used in the navy exceed two hundred, and they vary from four to twenty-eight inches in length. Those above eighteen inches are more sparingly used, and the shells of the largest kinds are made in parts, and fitted together by hand.

To the completion of this ingenious machinery, Brunell gave his whole attention from the month of September 1802 to June 1808, during which time he received no other compensation beyond the daily allowance of one guinea; but as it was now in full operation, and ascertained to be capable of making a sufficient number of blocks for the whole naval and ordnance departments, it became a question in what manner the author of the invention should be rewarded. It was suggested by General Bentham, and agreed to by Brunell, that the savings of one year, as compared with the contract prices, would be a fair and not an unreasonable remuneration for the time, labour, and ingenuity, bestowed on these extraordinary machines. It was no easy matter, however, to ascertain with precision what the actual savings amounted to.

Mr Brunell, by estimate, made them amount to	L. 21,174	0	0
Mr Rogers, clerk to General Bentham, by estimate	12,742	0	0

General Bentham, after going into every possible details of expence with the utmost minuteness that could be expected in a private manufacturing concern, calculated them at	L. 16,621	0	0
Add six years' allowance at a guinea a-day, about	2,400	0	0
For the working-model	1,000	0	0

Total amount received by Brunell, about	L. 20,000	0	0
---	-----------	---	---

Supposing, therefore, the whole cost of the buildings, steam-engine, machinery, interest of money, &c. to amount (which we understand to be about the mark) to L. 53,000, and the net compensation for profits to about L. 18,000, the whole expence of the concern was completely cleared in four years. The savings of L. 18,000 on one year's manufactured articles of the value of L. 50,000, amounts to somewhat more than Brunell had originally made it by computation.

It would occupy too much space to enter into a minute description, and require more time than we can spare, to prepare engravings in detail of the various complicated systems of machinery that are employed for the completion of a block; and, after all, they would afford but little use or instruction, excepting perhaps to a professed machinist; and perspective views of the several systems would tend rather

Block-Machinery.

to mislead or confuse, than to inform the general reader. But as every body who happens to inspect Portsmouth dock-yard, makes a point of visiting the block-machinery, we think it may be of some use, in conveying a general idea of the most striking parts of the machinery, by following the process of making a block from the rough unsided tree, till the last finish is given to it.

We have stated, that the original intention of the building was that of a wood-mill, in which all manner of sawing, turning, boring, rabbetting, &c. was to be performed, and that the block-machinery was superadded to the first design, with which, however, it has interfered so little, that, in addition to the immense number of blocks manufactured at the mill, upwards of a hundred different articles of wood work are made by other machinery—put in motion by the same steam-engine, from the boring of a pump of forty feet in length, to the turning of a button for the knob or handle of a drawer. (See DOCK-YARD, PORTSMOUTH.) Lest, however, the engine, with such a variety of work, might be overloaded, a second engine has been added, to assist, if found necessary, or to substitute in the event of accident happening to the other. Among the many ingenious machines belonging to the wood-mills, exclusive of those for making blocks, one of very great effect, and, at the same time, great simplicity, is a circular saw for cutting rabbets in the edges of deal planks, invented by Mr Burr, the superintending master of the wood-mills.

The whole of the machinery in these mills is put in motion by straps passing over drum-heads, by which the several movements, numerous as they are, are carried on without the least noise; and all the engine-work, and every part of the machinery, are so truly made, and so firmly put together, and work with such accuracy in all their motions, that, though the spectator is surrounded on all sides with movements in every possible direction, and some most rapid and violent, the only noise that disturbs him arises from the cutting, boring, turning, polishing, and other instruments which are actually in contact with the work that is under execution, and none of it from the working of the machinery. All the iron work, of which it is chiefly composed, was made by Mawdsley; and there is but another workman, perhaps, in the United Kingdom, who could have finished the engines in a manner so worthy of the invention.

The first wing of the building is chiefly occupied by upright and circular saws, used for a variety of purposes not immediately connected with the making of blocks. The only operation for this department is that of converting the rough timber, which is generally elm or ash, most commonly the former, into its proper scantling; that is to say, squaring it by the upright or straight-cutting saw, and then, by a circular saw, cross-cutting it into a certain number of parallelo-pipedons, whose lengths may bear the required proportion to the thickness of the log. Some of these pieces are again cut longitudinally, according to the thickness that may be required for the shell of the block, especially those for single and double blocks, which of course are thinner than three and four-

Block-Machinery.

fold blocks. This operation is performed by what is called a ripping-saw. The logs thus cut out are then taken into the second wing of the wood-mills, where the machinery peculiar for the construction of blocks is erected; and here the first process may be said to commence in making the SHELL.

This operation is performed by the *Boring-Machine*, which, by means of a centre bit applied to the middle of the shell, bores a hole for the centre pin of the sheave, while another bores one, two, or three holes, at right angles to the direction of the first, to admit the first stroke of the chisel, and, at the same time, to serve for the head of the mortice or mortices, according as the intended block is to contain one, two, or three sheaves. When thus bored, the log is carried from hence to the

Morticing-Machine, which is an ingenious and striking piece of mechanism. The block being firmly fixed on a moveable carriage, the latter is so contrived as to be made to advance to the cutting chisels, which are set fast in a moveable frame. Every time the frame, with the chisels, ascends, the block in its carriage advances a little, so as to present to the chisels a fresh surface of wood to be acted upon at each stroke of their descent; and this up and down motion is continued with such rapidity, that the chisels make from one hundred to one hundred and thirty strokes in a minute, until the prescribed length has been morticed out; when, by raising a handle, which is done by a boy, the machine is stopped precisely when the chisels stand at their greatest elevation; and are thus left in the proper position, ready to commence a second operation. No harm, however, would happen either to the block or the machinery, should the attending boy neglect to stop the work at the proper time, or even to fall asleep, notwithstanding the force and rapidity of the stroke; for, by a particular contrivance, the farther advance of the block is stopped, and the chisels, therefore, act in full space, and cut only the air. It is, indeed, a general characteristic of Brunell's machinery, to be so constructed as to carry with it a defence or protection against its own operations, and to counteract all ill effects that might otherwise arise from any neglect or inattention of the workmen.

The chips cut by the chisels are thrust out of the mortice by small pieces of steel attached to, and projecting from, the back of each chisel. They are each of them, besides, armed with two cutters placed at right angles to the edge, called *scribers*, which mark out the width of the chip to be cut by the chisel at each stroke. These sscribers answer another purpose; their cutting is so true as to leave the two sides of the mortice so perfectly smooth, as to require no further trimming or polishing.

The next process is to remove the block from the morticing machine to a circular saw, in order to have the four corners taken off, by which operation it is reduced to an octagonal shape. This saw being fixed into a table or bench, the workman has nothing more to do than to slide each log along the surface of the table, in the direction of the line marked out for the saw to cut it.

The next operation is to place the block upon the *Shaping Machine*. This is perhaps one of the most

ingenious and most effective contrivances in the whole machinery of the wood-mills. It consists principally of two equal and parallel circular wheels moving on the same axis, to which one of them is firmly fixed, but on which the other is made to slide; so that these two wheels may be placed at any given distance from each other, and blocks of any size admitted between their two rims or peripheries. For this purpose, both rims are divided into ten equal parts, for the reception of ten blocks, which are firmly and immovably fixed between the two wheels. When the double wheel with its ten attached blocks is put in motion, the outer surfaces of the blocks, or those which are farthest from the centre, strike with great violence against the edge of a chisel or gouge fixed in a moveable frame, which, being made to slide in a curved direction in the line of the axis, cuts those outward faces of the blocks to their proper curvature, which can be altered in any way the workman pleases, by a contrivance attached to the cutting tool. As soon as the tool has traversed the whole length of the block, or over the space contained between the two peripheries of the wheels, the machine is thrown out of the gear, and its prodigious velocity checked by a particular contrivance. The ten blocks are then, by a single operation, and without removing them, each turned one fourth part round, and another fourth part of their surface brought outwards, which, being exposed to the cutting instrument traversing in the same direction as before, have the same curvature given to these new surfaces. A third side is then turned outwards, and, after that, the fourth and last side, when the whole ten blocks are completely shaped, and ten other octagonal logs applied to the peripheries to undergo the same operation.

The immense velocity with which the wheels revolve, and the great weight with which their peripheries are loaded, would make it dangerous to the workmen or bystanders, if, by the violence of the centrifugal force, any of the blocks should happen to be thrown off from the rim of the wheels; to prevent the possibility of such an accident, an iron cage or guard is placed between the workman and the machine.

The shell of the block being now mortised and completely shapen, the last operation is performed by the *Scoring Machine*, which, by means of cutters, scoops out a groove round the longer diameter of the block, deepest at the ends and vanishing to the central hole for the pin on which the sheave turns. The intention of this groove or channel is to receive the hempen or iron strap which surrounds the block. The only thing that now remains for completing the shell, is the removal of the little roughnesses from the surface, and giving to it a kind of polish, which is done by the hand.

The SHEAVES. The wood generally used for making sheaves is *lignum vitæ*; but iron or bell-metal have occasionally been substituted for this wood. An attempt was made to introduce sheaves of a kind of porcelain, which answered well enough for some particular purposes, but were not to be trusted in situations where they were liable to sudden jerks and irregular motions. In the navy they are almost invariably of *lignum vitæ*, a few perhaps of ebony. The machinery employed for making this

Block-Machinery.

Block-Machinery.

part of the block, consists of a *Circular Saw* by which the log is cut into plates of the thickness required for the sheaves, according to their several diameters. These plates are next carried to a *Crown Saw* which bores the central hole, and, at the same time, reduces them to a perfect circle of the assigned diameter. The sheave, thus shaped, is next brought to the *Coaking Machine*, a piece of mechanism, not inferior in ingenuity to the *Shaping Machine*, for the shells. It would be useless to attempt to describe, by words, the movements of this engine, but the effect of the operation is singularly curious. A small cutter, in traversing round the central hole of the sheave, forms a groove for the insertion of the coak or bush, the shape of which is that of three semicircles not concentric with each other, nor with the sheave, but each having a centre equally distant from that of the sheave. The manner in which the cutter traverses from the first to the second, and from this to the third semicircle, after finishing each of them, is exceedingly curious, and never fails to attract the particular notice of visitors. So very exact and accurate is this groove cut for the reception of the metal coak, and so uniform in their shape and size are the latter cast in moulds, that they are invariably found to fit each other so nicely and without preparation, that the tap of a hammer is sufficient to fix the coak in its place. The coaks are cast with small grooves or channels in the inside of their tubes, which serve to retain the oil or grease, without which it would soon ooze out, and the pin become dry.

The sheave, with its coak thus fitted in, is now taken to the *drilling-machine*, which is kept in constant motion. In casting the coaks a mark is left in the centre of each of the three semicircles. This mark is applied by a boy to the point of the moving drill, which speedily goes through the two coaks and the intermediate wood of the sheave. A copper pin, cut from wire, of the proper length and thickness, is inserted into the holes thus drilled. And the sheave is then taken to the *rivetting-hammer*, which is something like a small tilt-hammer, and can easily be made to strike on the pin with greater or less velocity, according as the workman presses with more or less force on the treadle. The rivetting being performed, the next operation is that of broaching the central hole on which the sheave turns, by means of a steel drill or cutter.

The last process is that of turning a groove for the rope to run in round the periphery of the sheave, and this operation is performed by a lathe, which is so constructed, that while this groove is cutting round the rim of the sheave, another part of the engine is turning smooth the two surfaces or faces of the sheave; and this lathe can be made to adapt itself to sheaves of different diameters.

The shell and the sheave being now completed, there remains only the iron pin, which, passing through the two sides of the former, serves as the axis on which the latter turns within the mortice. These pins are also made, turned, and polished by engines for the purpose, so that, with the exception of strapping by rope or iron, the whole block is completed at the wood-mills. It may here be remarked, that the French, in the dock-yard of Brest,

have long been in the practice of making blocks by machinery; but they have not attempted anything like a *Shaping-Machine*, nor any substitute for it; the external shape of the shell being made entirely by hand; nor have they such a *Coaking Machine* as that invented by Brunell. The machinery at Brest is put in motion by horses. (See DOCK-YARD.)

BLOW-PIPE, an instrument for directing the flame of a lamp or candle horizontally, so as to communicate an intense heat to small bodies placed in the flame. This is effected by impelling through a small aperture, against the flame, a stream of air moved with velocity, by means of the muscles of respiration and the mouth, or by a bellows. The Blow-pipe is used in soldering, by the jeweller and goldsmith, and other artists, who fabricate small objects of metal; by the glass-blower, in making thermometers and barometers, and other instruments made from the tubes which are got from the glass-house; by the enameller; and in glass-pinching, which is the art of forming glass in a mould fixed on a pair of pincers, into the ornamental pendants for glass lustres. This is one of the many ingenious processes carried on at Birmingham. The glass-blower, the enameller, and the glass-pincher, work their blow-pipe with the blast from a pair of bellows. As the process of soldering requires a shorter continuance of the blast, the blow-pipe for this purpose is blown by the mouth. By the mineralogist and chemist, the blow-pipe is used as an instrument for extemporaneous analysis in the dry way.

Fig. 1. Plate XXXIV. is the common blow-pipe used in soldering; it is of brass. Fig. 2. is Dr Wollaston's blow-pipe, which is composed of three tubes of brass, of an elongated conical form, which are made to fit stiff and air-tight into each other when in use, and the two smaller pack into the largest; so that the instrument, when not in use, occupies a very small space, and may be carried in the pencil-case of a common pocket-book. This, with a piece of platina-foil, two or three inches long, to hold the object of experiment to the flame, constitutes a commodious domestic apparatus for the travelling mineralogist. The three parts of the tube are represented, packed the one within the other, at A, separate at B, and put together ready for use at C, fig. 2.

A second division of blow-pipes consists of those which have a cavity for the purpose of retaining the humidity of the breath, which, without this precaution, collects into drops when the blowing is continued long, and is at last driven upon the matter under operation so as to cool it. They are of various forms; see figures 3, 4, 5, 6, 7; and have been contrived for the purposes of the chemist and mineralogist. Fig. 3. is of glass or of metal. Fig. 4. is of brass or of silver, containing no alloy of copper, so that it may not be subject to green rust. This is the form recommended by Bergman in his treatise on the application of the blow-pipe to the purposes of the mineralogist, which is contained in the collection of his works. (See *Bergmani Opuscula*, Vol. II.) For the facility of cleaning, it is in three pieces, which fit in stiff at A and B. Fig. 5. is of tin, that is to say, tinned iron; the small pipe A is of brass, and has two or three caps that fit on stiff; each cap is pierced with a hole of a different diameter, and as the blast

Block-Machinery
Blow-pipe.

Different Forms of Blow-pipe.

Bulbed Blow-pipes.

Blow-pipe. issues through this hole, the force of the blast may be varied by changing the cap: this is called Dr Black's Blow-pipe. Fig. 6. is of silver; the adjutage, which is of platina, turns on an axis at right angles to the main tube at A, so that it may be made to form different angles with the main tube; the prolongation B, serves to receive the condensed vapour of the breath. Fig. 7. is of brass; A is cylindrical, the axis of the cylinder being at right angles to the axis of the blow-pipe. A consists of two pieces, one of which fits air-tight into the other, and may be turned on its axis, so that the pipe of issue may be made to form different angles with the axis of the blow-pipe, as the position of the matter under experiment may require.

Flame.

Flame consists of vapour in a state of incandescence. Many substances, both of the vegetable, animal, and mineral kingdoms, have the quality of giving out this incandescent vapour. For domestic uses, and for the arts, organized bodies of the vegetable and animal kingdom alone are employed to produce it; such as oils, some of which are solid, others fluid, at the usual temperature of the air, alcohol, ether, wood, and pit-coal. This latter, though found amongst minerals, is composed of organized matter, changed and rendered bituminous by a particular process of decomposition. The blow-pipe, by directing the incandescent particles of which the flame consists, so as to strike against and surround a small body, produces the effect of heating the body considerably. The flame used with the blow-pipe, may either be the flame of an oil or spirit lamp, or of a candle; the flame of the carbonated hydrogen gas proceeding from the distillation of pit-coal, is also found advantageous for this purpose.

Mode of Blowing.

In order to use the blow-pipe, the breath impelled through it is to be directed across the flame of a lamp or candle, applying the orifice from which the air issues a little above the upper end of the wick; a jet of flame is thus formed, as represented at fig. 8. This jet is made to fall on the body to be heated. The operation may be continued for a considerable length of time; an uninterrupted blast is kept up by the muscular action of the cheeks, whilst the ordinary respiration goes on through the nose: a little practice is sufficient to enable the operator to succeed. The jet of flame is conoidal, internally blue, and externally yellow, by more or less immersion in this jet of flame. The subject of operation receives a greater or less degree of heat, and becomes oxidated in a greater or less degree. If a bead of borax, containing oxide of manganese, be kept fused for some time in the inner flame, the bead becomes colourless; when it is afterwards kept fused in the outer flame, the manganese acquires more oxygen, and the bead becomes of a violet colour. This violet colour may be made to appear more speedily, by adding a particle of nitre.

Use in Mineralogy.

The first who applied the blow-pipe to the analysis of minerals was Swab, Counsellor of the College of Mines in Sweden, in 1738. Its application to the science of Mineralogy was afterwards farther improved by Cronsted, Rinman, Gahn, Scheele, and Bergman, and by other men of science since their time.

The blow-pipe is useful to the mineralogist and chemist, as affording a ready method of knowing what the component parts of bodies are. Trials with the blow-pipe are generally made by the chemist in order to know the nature of the constituent parts, before he proceeds to the other steps of dry or humid analysis, which are requisite for ascertaining the quantities of the constituent parts. Then recourse is had to other means than the blow-pipe; for, in order to come at a knowledge of the proportions of the constituent parts, it is necessary that the quantity of each constituent part be large enough to be weighed in a balance, and, for this purpose, the quantity of the substance employed must be larger than what can be managed with the blow-pipe.

In experimental mineralogy, with the blow-pipe, the small fragment of the body, subjected to trial, should not exceed the size of half a peppercorn; if larger, it cannot be sufficiently heated. It is placed in a lenticular cavity, made with a knife, in a piece of well burnt charcoal of wood, free from cracks, and not too porous, and of the length of four or five inches, so as to be held conveniently in the left hand. Some blow-pipes have been made with a stand, to which they are connected by a ball and socket joint; the stand is fixed to the table by a clamp; this construction leaves the right hand at liberty. In reducing fragments of metallic ores by the blow-pipe, charcoal should be used as a support, as the charcoal attracts the oxygen from the metallic oxide, and reduces it to a metallic form; and when thus reduced, the metal may be kept fused on the charcoal, which prevents or retards its again attracting oxygen. The charcoal support has likewise the advantage of increasing the heat by its incandescence. For both these reasons, to prevent oxidation, and to increase and reverberate the heat proceeding from the jet of flame, the goldsmith who solders his small work by the blow-pipe, attaches his work to a piece of charcoal, by means of wires, in the process of soldering.

When it is required that the fragment of a mineral should be heated, without the contact of charcoal, the fragment is exposed to the flame in a small spoon of platina, with a wooden handle; the cavity of the spoon is a hemisphere of three-tenths of an inch in diameter; or on a thin lamina of platina two or three inches long, and half an inch broad, and of the thickness of common writing paper; or it is held by a forceps, three inches long, made of thin platina. Bergman, who published his treatise on the blow-pipe in 1780, before the working of platina had come into use, employed a small gold spoon, as that metal has the quality of remaining pure and uncontaminated, whilst in contact with many of the chemical agents; but platina is preferable, for, besides possessing the quality of resisting the action of many chemical agents, it has likewise the advantage of difficult fusibility. It has now, for a good many years, been wrought into various instruments both in London and Paris; when wrought, it is sold at the price of about a guinea the ounce, which is one quarter the price of gold. Some platina workers, as Jeanetti of Paris, who was one of the first, form the

Blow-pipe. crude granular platina into masses, by melting it with arsenic, and subsequent heating and forging; others dissolve the crude platina in nitro-muriatic acid, and reduce the nitro-muriate of platina to a metallic state by heat. Platina, however, although infusible alone by the heat of the common blow-pipe, will be dissolved and melted, if heated along with some of the metals. Platina supports, therefore, should not be used where they are liable to be in contact with a fused metal. These effects are notable in the case of tin; when tin is melted in contact with a vessel of platina, the tin enters into a combination with the platina, corrodes and renders it brittle, so that pieces of the platina vessel come off on the application of a small force, and the vessel is thus rendered useless. Platina vessels also become unserviceable by frequent and continued exposure to great heat. Platina crucibles that are much used become brittle, and crack at the edges; and care should be taken to cool these vessels gradually, that they may last as long as possible. A platina vessel, in which sulphuric acid was boiled, for a long time, at last became perforated and unserviceable.

Fluxes. Borax (borate of soda) is used along with the fragment of mineral in many cases. When exposed to the flame, it becomes opaque, swells and ramifies much, in consequence of parting with its water of crystallization; afterwards it fuses into a colourless and transparent bead. It is convenient to use calcined borax, which is borax deprived of its water of crystallization by heat in a crucible; this melts into a bead on the charcoal at once. The solubility of a mineral in borax, with effervescence, or without effervescence, and the colour that the mineral communicates to the borax, are the chief distinctive characters obtained by treating a mineral with that substance. Phosphate of ammonia is also sometimes used as a flux in the same manner as borax, and carbonate of soda; but both these, especially the latter, have the inconvenience of sinking into the charcoal, which borax is free from.

Characteristic Phenomena of Minerals, treated by the Blow-pipe. Mention may be made here of a few of the most prominent phenomena, characteristic of different mineral substances when treated by the blow-pipe. Some minerals are fusible alone, such as garnet and felspar; this last is rather difficult to fuse. Some are infusible and change colour; bituminous shale loses its black colour, and becomes white, green, and dark; coloured steatite become white. Some dissolve in borax without effervescence, as agate, quartz, felspar, amiantus, garnet. Some dissolve in borax with effervescence; this is the case with carbonate of lime; it forms with borax a globule transparent whilst in fusion, but in cooling it, the globule becomes opaque, the lime being no longer held in solution by the borax; in like manner, as the watery solutions of certain salts, saturated when hot, deposit a part of the salt on cooling. Some of the metals communicate peculiar colours to borax. Copper, in certain proportions, and at a certain degree of oxidation, gives a brown colour to borax when heated by the blow-pipe. Cobalt gives a deep blue tinge. Manganese a violent colour. Iron tinges borax brown, and if in greater quantity black. These colours are produced by the metals in a state

of oxide. The smell emitted by some minerals, when heated by the blow-pipe, is another character serving to distinguish them. That of minerals containing sulphur, is the peculiar suffocating smell of sulphureous gas; minerals that contain arsenic, emit, when heated, a smell like that of garlic. The nature of some minerals is recognised by the particular form of crystallization which they assume in cooling; this is the case with phosphate of lead, which, after being fused, cools on the charcoal into an opaque white spheroidal polyhedron. Some ores are reduced to a metallic globule, with great ease, on the charcoal; thus the native sulphuret of lead, called Galæna, being heated by the blow-pipe, the sulphur is driven off, and the lead remains in its metallic state. A small particle of silver may be melted by the blow-pipe, likewise gold, copper, and, Bergman says, cast-iron. Metallic zinc, when exposed to the flame of the blow-pipe on the charcoal, melts and burns with a bluish green flame, and becomes covered with oxide, which flies off and floats in the air in light white flocks. Metallic antimony becomes red hot, and melts on the charcoal; and if the operator ceases to blow, a white fume rises, and oxide of antimony forms upon the globule, in whitish crystalline spiculæ: if the globule, in a state of fusion, be thrown upon a brick floor, it runs along for a considerable way, rebounding several times, and leaving a trace of white oxide of antimony.

Some substances communicate colour to the flame of the blow-pipe. Muriate of copper, whose crystals are green, communicate a vivid green to the flame; sulphate and nitrate of copper, whose crystals are blue, likewise impart a green colour to the flame when they are exposed to its action. Some of the salts of strontian give a purple tinge to the flame.

What precedes relates to the blow-pipe worked by the breath. When it is required to continue the use of the blow-pipe, so long as would be fatiguing if the breath merely were employed, the glass-blowers' table, fig. 9. Plate XXXIV. is used. It consists of a double bellows, so fixed as to be worked by the foot, and to impel a current of air through a tin blow-pipe, against the flame of a lamp fixed on the table. For the sake of durability, the blow-pipe is sometimes of brass, on which is screwed a nozzle of platina. The blow-pipe may have a stop-cock, as in fig. 9. serving to regulate the blast. The lamp has a cotton wick of nearly an inch in thickness; the wick is kept together by a tin wick-holder, which is soldered to the lamp; melted tallow fills the lamp, and feeds the wick with fuel. In order to get rid of the smoke, which is in considerable quantity, there may be placed, at a convenient distance above the flame, a tin funnel ending in a tube, which conveys the smoke out of the room. A convenient method of carrying away the smoke from the glass-blowers' lamp, is represented in fig. 13. It consists of a cover of thin sheet copper, which is placed on the table, covering the lamp and nozzle. The fore-part of this cover is open, so as to allow the jet of flame to pass freely. From the upper part of the cover two tubes go upwards for the exit of the smoke; between

Blow-pipe. these two tubes the glass-blower has a view of the object he is at work upon, whilst his eyes are screened from the light of the flame. The two tubes join above in one short tube. Over the open end of this short tube, at a small distance above, is a tube suspended from the ceiling by wires, which conveys the smoke into the chimney of the room. By a handle attached to the cover, the cover with its tubes is removed when it is necessary to trim the wick. The flame of gas from pit-coal may be used instead of a lamp, with a bellows of this kind.

Water-pressure Apparatus.

The regularity of the blast in the double bellows, is effected by means of a weight pressing on the air contained in the second compartment of the bellows; just in the same way as a stream of air is made to issue regularly from a tube fixed in the mouth of an inflated bladder, when a weight is placed on the bladder. A regular stream of air may also be obtained, by subjecting inclosed air to the pressure of a column of water, mercury, or some other liquid. If a vessel containing air, and open at the mouth, be plunged into water with the mouth downwards, and if the water on the outside of the vessel rise higher than the surface of the water within the vessel, then the column of water, whose height is the difference of level, exercising its pressure, as all liquids do, in every direction, acts upwards on the inclosed air; and the inclosed air will be pressed and more condensed than the external air, and will escape in a current, by a stop-cock opened on the top of the vessel for its issue; this issue will continue till the surface of the exterior and interior water come to a level; for then the air in the vessel is come to have the same density as the external air. The force with which the inclosed air is pressed, is equal to the weight of a volume of water whose height is the difference of levels, and its base the surface of water exposed to the inclosed air. The gasometers used by Lavoisier, to afford a stream of oxygen gas and a stream of hydrogen gas, for accomplishing the composition of water, are constructed upon this principle. An apparatus of the same nature has, for many years, been employed in the great way, in different parts of Britain, to regulate the most powerful blast used in the arts,—that for reducing ironstone to the state of cast-iron. In blast-furnaces upon this construction, the blast is raised by means of a large cast-iron cylinder which acts as a bellows, having a valve in the bottom that opens inwards, and that admits the air during the ascent of the piston; when the piston descends, the valve shuts, and the air is driven into a large parallelepipedal vessel, less in height than in the other dimensions, immersed in water, and having its under surface closed only by the water. In this vessel the air is pressed by the column of water, whose height is the distance between the surfaces of the exterior and interior water; a pipe of issue terminating in a nose-pipe, conducts the blast to the furnace.

Melograni's Blow-pipe.

The blow-pipe of the Abbé Melograni of Naples, for the use of the mineralogist, operates by the pressure of water. It is composed of two hollow globes, the upper filled with water, which, by running into the lower, forces the air contained in the lower to

issue through a nozzle. This apparatus is described by Mr Greenough, in *Nicholson's Journal*, Vol. IX. p. 25 and 143. It has some inconveniencies, and does not appear ever to have come into much use.

The water-pressure apparatus, applied to the blow-pipe, of which a section is given at fig. 10, was contrived by Mr Tilley, an ingenious fancy glass-blower. It consists of a tin box with a partition in it, reaching within half an inch of the bottom; water is poured in equal in bulk to three-fourths of the capacity of the box. The water in the cavity DE is open, and subject to no other pressure but that of the atmosphere, being only covered by the lid of the vessel; the apartment F is closed at top, so as to be air-tight, and the water in it is pressed by the elasticity of the air confined in its upper part. The tube C has its lower extremity always plunged in water, so that, when air is blown in through it, the return of the air by that tube is prevented. Before the apparatus is set to work, the surface of the water in both compartments is at the same height, both being pressed by air of the density of the surrounding air; but, when air is blown in through C, the air rises through the water to the top of the compartment F; and as the only issue for the air is through the small aperture of the blow-pipe, by which it cannot escape nearly so fast as it is blown in, the air consequently becomes condensed in the upper part of the compartment F; and this condensed air pressing on the water in F more strongly than the atmosphere does on the water in DE, depresses the surface of the water in F, and causes it to rise in DE, which is effected by a portion of the water passing under the partition into the open compartment DE. Thus the pressure exerted by the column of water whose height is the difference of level of the water in DE, and of the water in F, forces the air from the compartment F through the blow-pipe *a*, which is directed against the flame of a lamp; and this pressure keeps up a constant blast till the water in the two compartments comes nearly to the same height. The degree of condensation of the inclosed air, and the height of the column of water pressing on the condensed air, are measures of each other, when much air is blown in, so as to occasion a considerable degree of condensation. The difference of level resulting is considerable; and the column of water, which is always reacting with an equal and contrary pressure on the condensed air, causes it to issue with greater velocity from the blow-pipe: when the condensation diminishes, so does the column of water, and the velocity of the issuing stream of air. More air is to be blown in with the mouth through the tube C, from time to time, so as to keep the blast regular. Mr Tilley is of opinion that this apparatus produces a more regular stream of air than a double bellows, and it has likewise the advantage that the operator is free from the trouble of moving a pedal. The dimensions of the vessel AA, which is either of tinned iron or of tinned copper, are 17 inches in height, 5 inches in width, and 9 in breadth; the lid of the vessel opens and shuts on hinges, and supports the tallow lamp B. The bent glass tube *a*, which terminates in a

Blow-pipe. small hole, is fitted air-tight into a tin tube, which is made conical, and which forms the issue from the top of the copartment F; for this purpose, paper is wrapped round the glass tube, and then cotton wick yarn, in a conical form, so that the glass tube thus clothed may fit tight into the socket, and may nevertheless be moved round, that the blast may act properly on the flame. The bent metal tube C is also fixed into its socket in the same manner; its junction with the socket is seen in fig. 10. There is a screen formed of a tin plate sliding vertically in grooves between two upright pieces of tin; the edge of this is seen at S, in fig. 10. It is intended to protect the eyes of the operator from the light of the lamp, whilst, at the same time, he can see the subject of his operation over the top of the screen. This screen is not soldered to the vessel, but is held fast by its foot being placed between the lid of the vessel and the top of the close chamber F. Two rests for supporting the operator's arms project one from each side of the vessel; upon these the arms are placed when any substance is held to the flame. These rests are wrapped round with woollen list or leather, so as to be more convenient for leaning upon. The whole of the apparatus, including the lamp and case, weighs only three pounds and a half. When it is to be used, the vessel is fixed to a table or bench, by means of a leather strap buckled to two loops, which are on the sides of the vessel opposite to each other; the strap is passed under the table or bench. The long flat cotton wick is preferred by some glass-blowers to the usual round cotton wick. The lamp is filled with tallow, which melts after the lamp has been lighted for some time, and then it burns as freely as oil, and with a less offensive smell. When not in use, the tallow becomes solid, and is more conveniently carried about than oil: hogs' lard also does well for burning in this lamp. Some glass-blowers mix cocoa-nut oil, which is solid, at the temperature of the climate of Britain, with hogs' lard, and find it to answer well in the lamp. The lamp is placed within another vessel, marked K, which supports it at a proper height, leaving a space between all round, to receive any tallow that may run over the edge of the lamp. A wire bent at the end is convenient for trimming the wick, and forming it into a channel through which the stream of air is to be directed. It is convenient to have several lamps with wicks of different thicknesses, namely, one to hold two flat cottons of about one inch and a quarter broad, another to hold four, a third to hold six, or as much common wick-yarn as is equal to those wicks in bulk, and glass adjutages of different sized apertures to suit the different sized wicks. See *Transactions of the Society for Encouraging Arts*, Vol. XXXI.

Eolipile.

The Eolipile, fig. 11., Plate XXXIV. has been applied to act as a blow-pipe. It is a hollow vessel of brass, sometimes made in form of a small kettle, sometimes in form of a ball of two inches in diameter, with a tube of brass that screws into it. The tube is to be screwed off in order to pour in alcohol by a small funnel; and then the tube being replaced, and heat applied to the bulb, the vapour of the alcohol issues

from the small aperture of the tube, and being directed against the flame of a lamp, the flame is driven in a horizontal stream, such as the blow-pipe produces. The instrument has a safety-valve (S) to prevent the danger of explosion, which might happen if the nozzle were stopped. The same wick that heats the bulb may serve to furnish the jet of flame, as is the case in the eolipile represented in fig. 11. This instrument has been proposed to be applied to the purposes of the mineralogist; but it does not appear to be either so readily put in action, or so efficacious as the common blow-pipe, which is also simpler in its construction, less bulky, and more easily carried about.

Mr Newman, philosophical instrument maker of Newman's Lisle Street, London, having observed that air, condensed in a cavity, required a considerable time to escape through a small aperture made to give it issue, contrived the apparatus represented at fig. 12., which acts as a blow-pipe. This apparatus consists of a strong plate copper box perfectly air-tight, three inches in width and height, and four in length, a condensing syringe to force air into the box, and an adjutage with a stop-cock at one end of the box, by which the issue of the air is regulated. The piston rod of the condensing syringe works through collars of leather in the cap, which has an aperture in the side, and a screw (N) connected with a stop-cock, which may be made to communicate with a jar, bladder, or gazometer, containing oxygen, hydrogen, or other gases. When this communication is made, and the condenser worked, the gas contained in the jar or bladder is thrown into the box, and issues through the adjutage upon the flame of a lamp placed near it. When the apparatus is worked with common air, a few strokes of the piston fills the chamber with compressed air. When the cock of the adjutage is opened, the air issues with great velocity in a small stream, and when directed on the flame of a lamp, produces a jet of flame as the common blow-pipe does, but with more precision and regularity. The force of the stream of air is easily adjusted by opening more or less the stop-cock of the adjutage; and, when the box has been moderately charged, the stream will continue to issue uniformly for twenty minutes; when the strength of the blast begins to decline, it will be restored by working the syringe. The apparatus is very portable, and not liable to injury. It is made by Mr Newman, the inventor, with a lamp adapted to it, so as to pack up in a box not more than six inches in length, and four inches in width and height, enough of space being left for other small articles: others he makes in boxes somewhat larger, so as to contain also a selection of chemical tests. See *Journal of Science*, edited at the Royal Institution, No. 1.

Sir Humphrey Davy having discovered that the explosion from oxygen and hydrogen gases would not communicate through very small apertures, Mr Children proposed to him to employ Newman's blow-pipe for effecting a combustion of a mixture of oxygen and hydrogen gas, issuing from a small aperture. This Sir Humphrey did, and found that the flame produced the most intense heat, which instantly fused bo-

Blow-pipe. dies of a very refractory nature. Dr Clarke, Professor of Mineralogy at Cambridge, having consulted Sir Humphrey on the subject, proceeded to expose a great variety of mineral substances to the flame, for the purpose of observing its effects upon each of them. The tube of glass through which the mixture of the two gases is to issue, is cemented on the pipe of issue of Newman's blow-pipe. The tube at first used by Dr Clarke was 3 inches in length, and the diameter of its cavity $\frac{7}{10}$ th of an inch. The end of the tube was constantly breaking during the experiments, owing to the sudden changes of temperature, until at last he usually worked with a tube only one inch and three-eighths in length. When the current of gas is feeble, from the gas in the reservoir having come nearly to the same degree of density as the surrounding air, or from the current being suppressed in the beginning of an experiment, then the flame has a retrograde movement, passing up the capillary cavity of the tube about half an inch, and, after splitting the end of the glass tube, the flame goes out of itself; so that, even in this case, there is no danger of explosion. In order to try the effects of an explosion, four pints of a mixture of the two gases were condensed into the chest, which was all that the syringe could force into it. The glass tube was taken off, so that the diameter of the nose-pipe, by which the gas was to issue, was about one-eighth of an inch. A burning spirit-lamp was placed at this aperture, and the stop-cock being opened by means of a long string attached to it, the whole gas exploded with a report like that of a cannon; the chest was burst, the stop-cock driven out, and one end of the chest was torn off and thrown against the wall of the room. This shows the danger of using the apparatus with too large an aperture, and the necessity of employing a capillary tube.

**Dr Clarke's
Experiments.**

When the mixture of the two gases is to be employed in Newman's blow-pipe, the chest is first exhausted of air, and then the gaseous mixture in a bladder, screwed on at N, is to be forced into the chest by the condensing syringe. The proportions of the two gases, which Dr Clarke found to produce the greatest heat, are, two volumes of hydrogen and one of oxygen gas. The intensity of the heat is much greater when the gases are pure; the oxygen procured from manganese does not produce nearly so great a heat as that got from the hyper-oxy muriate of potass. The intensity of the heat may be regulated, by allowing the gas to issue in a more or less copious stream, which is done by turning the stop-cock. The heat, Dr Clarke thinks, is greater than that produced by the largest galvanic batteries. Most substances hitherto tried, are fused by it, so that it is difficult to find supports for holding the subject of experiment to the flame. The supports employed by Dr Clarke were, charcoal, platina, a piece of tobacco-pipe, black lead. Lime, strontian, and alumine, were fused. The metal of strontian was got, and retained its lustre for some hours. The alkalis were fused and volatilized almost the instant they came in contact with the flame. Rock-crystal fused into a transparent glass full of bubbles. Quartz gave the same result. Opal fused into a pearly

white enamel. Flint fused rapidly into a white frothy enamel. Blue sapphire melted into greenish glass balloons, ramified singularly. Foliated talc fused into a greenish glass. Peruvian emerald melted into a transparent and colourless glass, without bubbles. Lapis lazuli fused into a transparent glass with a slight tinge of green. Pure foliated native magnesia, from America, is the substance the most difficult of fusion; it is, however, at last reduced to a white opaque enamel. Agalmatolite of China fuses into a limpid colourless glass. Iceland spar is next in difficulty of fusion to the native magnesia; it does at last melt into a limpid glass, and, during the process, gives an amethyst-coloured flame as strontian does; the fusion of pure lime and of all its compounds, is attended with a flame of the same colour. Diamond first became opaque, and then was gradually volatilized. Gold fused along with borax, on a piece of tobacco-pipe, was nearly all volatilized. Platina wire, $\frac{7}{10}$ th of an inch diameter, melted the instant it was brought into contact with the flame of the gas; the melted platina ran down in drops, and the wire burnt as iron wire does in oxygen gas. Brass wire burnt with a green flame, differing from the green flame that salts of copper give. Copper wire melted rapidly without burning. Iron wire burnt with brilliant scintillation. Plumbago melted into a bead which was attractable by the magnet. Blend or native sulfuret of zinc melted, and metallic zinc appeared in the centre of the melted mass. Metalloid oxide of manganese, crystallized in prisms, was reduced to a metallic state.—See Dr Clarke's *Account of his Experiments, in the Journal of Science*, edited at the Royal Institution, October 1816. (y.)

BLOW-PIPE, IN ANATOMY, a straight hollow tube of brass, of an elongated conical form, six inches in length, and open at both ends. The aperture of the large end is three-tenths of an inch in diameter, that of the smaller end is of the size of a needle's point. It is used for blowing air into the collapsed vessels of the dead subject, in order to know the course of these vessels. (y.)

BLOWING of a Fire-Arm, is when the vent or touch-hole is run or gullied, and becomes wide, so that the powder will flame out.

BLOWING-MACHINES, in the arts and manufactures, and in domestic economy, are instruments for producing a continued current of air, principally for the purpose of facilitating the combustion of fuel. The first idea of such a machine was doubtless derived from the lungs, which we are constantly in the habit of using for the purpose of blowing, but more especially in the simple and useful application of the blow-pipe.

Of these different machines, the common bellows Common Bellows bears the greatest resemblance to the lungs, and was, in all probability, the first contrivance for artificial blowing. In the first instance, this instrument might be a simple bag, capable of distension by a mechanical force, the air being drawn in and pressed out of the same aperture in the manner of breathing. The first improvement upon this simple form would be, to admit the air by a valve opening inwards when the bellows were distended, the blast outwards being

Fig. 1.



Fig. 3.

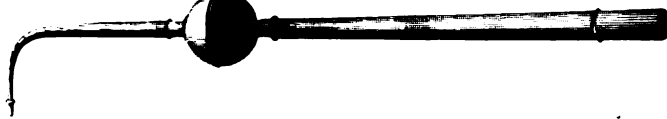

Fig. 2.

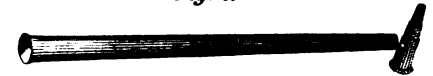

Fig. 6.

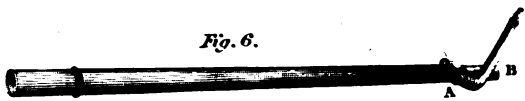

Fig. 4.

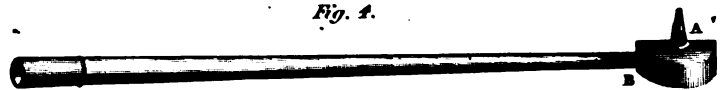

Fig. 7.

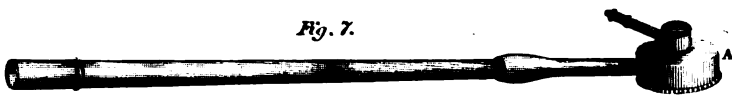

Fig. 9.

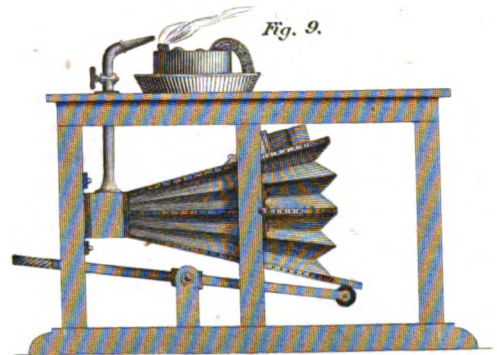

Fig. 11.

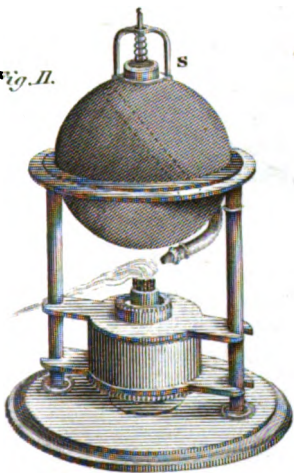

Fig. 6.

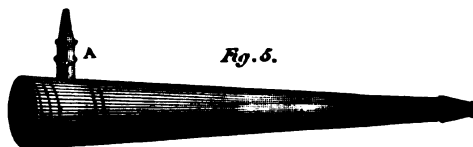

Fig. 13.

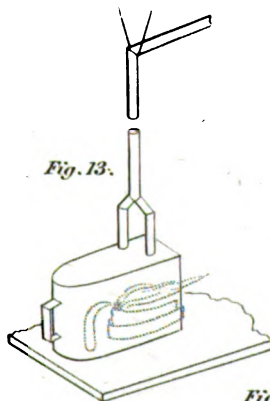

Fig. 12.

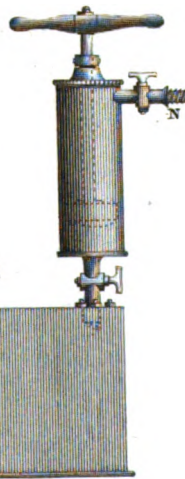

Fig. 8.

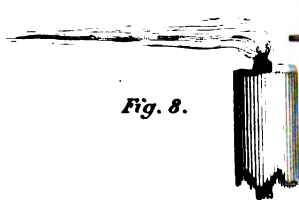
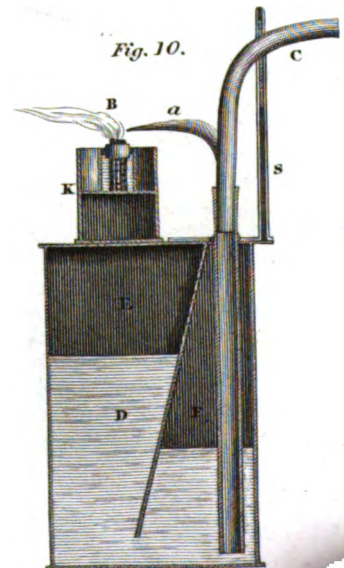

Fig. 10.



Blowing-Machines. from another aperture. This improvement consists in the air being admitted at a wider aperture, which fills the bellows in less time than would be performed through the small pipe through which the air should escape. The blast, in this state of the machine, is not continuous, but in puffs, at intervals of time required for the air to enter the bellows through the valve; the blowing interval being to the filling interval as the areas of the apertures. This irregular blast was for some time remedied by employing two bellows which blew alternately, the blowing on one taking place while the other was filling. This inconvenience was but partially remedied by this contrivance. The invention of what are called double bellows must have been considered a valuable acquisition in the art of blowing. Previous to describing these, it will be necessary to give a description of single bellows above mentioned.

Single Bellows. It will be needless, however, to say more than refer the reader to common domestic bellows, which are in every respect the same as the single bellows first used. The leather nailed to the upper and lower boards is prevented from collapsing, when the boards are separated by a hoop of wood contained within, performing the office of the ribs in the sternum of animals, without which the breathing would not be performed. The lower board contains the valve which admits the air. When the two boards are separated, the air lifts the valve in entering the cavity. When full of air, the closing of the boards causes the air within to close the valve to prevent its return in that direction, and compels it to escape at the pipe, the mouth of which is called the nozzle or nose-pipe.

Double Bellows. In order to conceive the construction of the double bellows, we have only to take a third board exactly of the shape of the other two, and connect it with the lower board by a piece of leather similar to that of the single bellows, making two cavities exactly similar, and separated by the lower board of the single bellows, which now becomes the middle board of the double bellows. The third board we shall now call the lower board. This latter has a valve in it exactly similar to the first, which still retains its place in the new construction.

The middle board is now fixed in a horizontal position, the pipe being placed to the fire to be blown. The lower board is held down by a weight, which keeps the lower cavity constantly full of air. The top board has a weight laid upon it which presses all the air out of the upper cavity through the pipe.

The machinal action by which the blowing is performed, is, first, to lift up the lower board. This forces the air from the lower into the upper cavity, the valve in the middle board preventing its return. The weight on the upper board now presses the air with a uniform blast through the pipe. During this time the lower board descends, which fills the lower cavity with air from the atmosphere. This again rises, and gives its contents to the upper cavity, and thence through the nose-pipe. Hence we see that irregular puffing blast which belongs to the single bellows is here confined to the lower board only, which sup-

plies air to the upper cavity, while the upper board is constantly pressing uniformly upon the air in it. Although this is a considerable improvement upon the single bellows, it does not completely obviate the irregularity of the blast. So long as the lower board is not in action, the pressure on the upper board being uniform, the blast is the same. Every time, however, the bottom board rises to force the air into the upper cavity, an extra pressure is given to the air in the upper cavity, and a temporary puff is produced. In the application of bellows to the smith's forge, the continued blast was of less importance than in the blast-furnaces applied to the smelting or refining of ores. The single bellows are at present almost exclusively employed by anchor-smiths and cutlers, while the blacksmith and most others use double bellows, which are doubtless better for all purposes.

Wooden Bellows. In France and other parts of the Continent, bellows have been formed entirely of wood, instead of the flexible sides of leather, which serves to increase and diminish the capacity. The wooden bellows consist of two boxes, each open on one side, the one being just capable of containing the other; the outer box being placed with the mouth upwards, the other is made to descend into it, with the mouth downwards; the latter being capable of moving up and down, while the other remained fixed. In the bottom of the fixed box is a valve like the common bellows, and a pipe on the same level, to let out the blast. The change of capacity, by the motion of this box, causes the blast, and with less waste of power than that occasioned by the bending of the leather in the common bellows. This advantage is, however, probably more than compensated by the loss of air, from the box not fitting on the sides. See a description of this and some other blowing-machines, under PNEUMATICS, in the *Encyclopædia Britannica*.

The common smith's bellows have lately been constructed of a circular form. The boards of these bellows are round, and the moveable boards parallel to the horizon and to each other. We have given a view of this construction in Plate XXXV. figures 4. and 5. A is the blast-pipe, B the moveable lower board, C the fixed board, into which the pipe is inserted, and D the upper moveable board, on which is placed a weight, to regulate the strength of the blast. Motion is given to the lower board by the lever L, and the chain H working on the roller R.

The form of these bellows being cylindrical, the weight required to give a given pressure and strength of blast will be easily determined. If the diameter be 1 foot, the area will be 113.19 inches. The most convenient and proper blast for smith's bellows is about $\frac{3}{4}$ lb. upon the inch, or from that to $\frac{1}{2}$ lb. The upper board, in this case, would require a weight of 56.5 to give a blast equal to half a pound upon an inch. This pressure would give a velocity equal to about 207 feet a second. If the diameter of the nose-pipe be changed, the number or length of the strokes, or both, must be changed, in order that the pressure and the corresponding density of the blast

Blowing-Machines.

may remain the same. If the number and length of the strokes were kept up, and the aperture diminished, at the same time that the capacity of the bellows will not admit of enlargement, the pressure and density of blast will be increased, although no additional weight is laid on. This frequently happens in the smith's bellows when he makes an increased effort to blow after the upper cavity is full. It is much better, however, not to exert the bellows in this way when a stronger blast is required, but to produce the effect by an additional weight. A very strong blast is found to be very injurious to the iron when welding heats are required, and still more so in working steel. It is much better that an increase of air, which is frequently wanted, should be furnished by increasing the aperture, supposing the power to be at the time adequate to keep up the increased supply. Bellows should therefore be so constructed that the pressure may be uniform, and not immediately under the control of the workman. When he wishes to quicken his heat, he should have the means of increasing the aperture by a circular plate turning on an axis at right angles, to the length of the pipe, as seen in fig. 9. When in the position *ab*, the whole area is filled; when in that of *cd*, the air passes in its full quantity. The index being placed at any intermediate points, *ef*, will let in any proportionate quantity required.

The aperture might be changed, by the increase of power upon the machine, and thus made to regulate itself. Several simple contrivances of this kind may be applied by any one skilled in machinery.

New Blowing-Machines.

These improvements would render the common leather bellows, of the form above given, very useful for smiths. The irregular blast occasioned by their present construction is found to be very injurious to the iron, both as to its quality and economy. This is abundantly shown in the use of some blowing-machines lately invented, which have the advantage of a uniform blast, and at the same time much softer, being produced by a small pressure.

These blowing-machines are also found to answer very well for melting cast-iron, the soft blast having less tendency to destroy the carbon the quantity of air being compensated by increasing the aperture.

One of these machines is the invention of Mr Street, for which he has taken out a patent. It consists of a barrel-shaped vessel, from 4 to 5 feet in diameter, and of a length more or less proportionate to the work it has to perform.

This cylinder is supported on two bearers by the two ends of its axis like a barrel churn. The cylinder is divided into two equal parts by a plane in the direction of its length, fitting the two ends and the upper side, water-tight, and extending downward to a small distance from the opposite side. This septum is in a perpendicular position when the cylinder is at rest. When this vessel is partly filled with water, and is made to pass through a certain space on its axis, the air which occupies the upper part of the vessel will be compressed on one side by the water, which flows from one side of the septum to the

other, and will become in the same degree rarified on the other, from a contrary cause. If, however, in this situation, a valve be made to open inwards from the atmosphere on the rarified side, and another to open outwards on the condensed side, two equal and contrary currents will be established, one inwards, and the other outwards. On the returning stroke both these valves will shut, and the other two sides will be put in the same situation with the first cavities. If, now, two similar valves to the last be introduced, two similar currents will be produced. If the two valves at which the air escapes from the machine, one on each side the septum, be made to communicate with one cavity from which a nose-pipe proceeds, while the other two valves communicate with the atmosphere, every stroke will discharge a quantity of air through the nose-pipe from one cavity, and introduce the same volume of air from the atmosphere into the other cavity. These strokes are produced by the oscillating motion of the machine, the limit of its vibrations being about a quarter of the circle or 90°.

These alternate puffs of air are first propelled into a vessel containing water to regulate the blast. This vessel is divided into two portions by a septum, which passes from the close cover at the top nearly to the bottom. When the air is forced into the cavity, which is close at the top, it expels the water under the septum at the bottom into the open cavity, so as to keep a constant head in the latter, compressing the air in the former. From this air-chest, a nose-pipe proceeds to the fire, and the air escapes from it with a uniform velocity so long as the same column of water in the chest is preserved. This description answers to the first machine of the inventor; he has since taken out a second patent; the specification of which is given in the *Repository of Arts*, Vol. XXVIII. p. 193. We shall here give a description of this machine, with the patentee's improvements. See Plate XXXV. figs. 1, 2, and 3.

Fig. 1. is a longitudinal section of this machine, AB is the cylinder resting upon the axis *ab* and *cd*, which are supported on the uprights *gg*. The oscillating motion is given to it by a rod working upon the pivot *p*, the other end of which is connected with a crank of such a length as to cause the cylinder to move through an arch of 90 degrees. The vessel is filled with water to the height *ws*.

The part CBD (fig. 2.) is cut off from the rest of the cylinder by two planes meeting at *c*, and continuing down to the axis *x*, so as to work upon its convex surface. These planes extend the whole length of the cylinder, and are then divided transversely into three cavities GHI, as seen in fig. 1. The cavity G is for the reception of the external air, and is called by the patentee a receiving box. The cavity H is open to the atmosphere, the periphery of the cylinder being removed in that part. The cavity I is appropriated to the air which is driven out of the machine, through the valves *tt* and *qq* (fig. 3.), which open alternately on each side. The cavity G is divided longitudinally in the middle, forming two cavities, *m* and *n*, fig. 2., two valves, *e* and *f*, fig. 1.,

Blowing-Machines.

open into each, one from the end of the cylinder, and the other from the cavity H. Each of the cavities *m* and *n* communicate with the body of the cylinder by the holes *hh* in the dividing planes. The cavity I has no division, as it receives the air from both sets of exit valves, which escapes at the pipe P.

The axis *av* works within the axis *ab* and *cd*, and is rendered air-tight by a stuffing-box within the latter. This axis will have the effect of remaining at rest, while the cylinder is in motion, there being no other force exerted to turn it than the friction of the stuffing-box. The use of this axis is to support and turn a swing valve MV, which is made of rolled iron, strengthened by ribs connected with the axis. This valve is a plane, which would exactly sweep the interior surface of the cylinder without touching it. If the axis *av* be held fast, the valve will retain its perpendicular position, while the cylinder performs its vibrating motion. The water would also remain at rest, with the exception of the motion which its friction and the compression of the air occasions. When the machine moves from D (fig. 3.), till the plane DC comes very near to the surface of the water *ws*, the valves *qq* open, and a volume of air equal to the space DCS will be expelled through the cavity I (fig. 1.), along the pipe P, during the time the valves in the cavity *m* (fig. 2.) have opened to admit the same volume of atmospheric air on the returning stroke. The point B is carried the contrary way, by which another portion of air opens the valves *tt* to pass through the pipe P, while the same volume of air from the atmosphere enters the cavity *n*, which in its turn is forced through the exit valves *tt*.

The use of the swing valve MV will now be obvious. If it did not exist, every time the air was compressed on one side, the water would be depressed on that side, and the compression of the air would be limited by the increased column of water on the other side. This valve, however, prevents the water from immediately changing its situation, no more escaping from one side of the valve to the other than what can pass between the edges of the valve and the cylinder, which, in the short space of one stroke, can be only a very small quantity. This may be considered as a great improvement upon the first machine, which we have before described. The patentee further intends occasionally to give to this swing valve a contrary motion to that of the cylinder, and thus still more increase the blast. Or, in the use of a very small blast, the valve may be left at liberty, and merely prevent the too great agitation of the water, which, in the original machine, was considered as an objection. Two of these machines are frequently used together, and worked by cranks, which make an angle of 45° with each other, to make the strong part of the blast of the one to occur with the weak part of the other.

The part I of the exit pipe PL, must be precisely in the centre of motion. The part L works in a stuffing part, or a ground socket connected with the pipe LN. The latter should communicate with a regulator which the patentee does not describe, but recommends one of water. This may be a vessel at

Blowing-Machines.

least of the capacity of the cylinder, inverted in a reservoir of water, and stand near to the bottom. The pipe N is inserted into the bottom, which is now uppermost; the height of the water in the reservoir must be equal to giving the required pressure to the air.

When the air is forced into the inverted vessel by the machiner, the water descends in this, and rises in the reservoir, which now gives a pressure to the continued air equal to the difference of the height of the water in the inverted vessel and the reservoir. The surface of the reservoir should be the greatest possible, in order that it may be raised in the least degree by the water which comes from the inverted vessel, which will have the effect of keeping the blast more uniform.

The water regulator is certainly the best for smiths' bellows, for refineries, forges, and perhaps the common melting furnace, but they have been found very objectionable in the blowing of large blast-furnaces. The air in the common blowing-engine, which has been already described under PNEUMATICS in the *Encyclopædia*, undergoes a great increase of temperature, during its passage through the machine, often as much as 40 or 50 degrees. The heated air has the effect of carrying a greater quantity of water along with it into the furnace, which destroys a larger quantity of carbon than the same bulk of common air, without producing an adequate portion of heat. A great part of the heat of the air is doubtless produced by the friction of the piston of the blowing cylinder, which, in this construction, has a very tight wadding. In the blowing-machine above described, the water would doubtless be an objection in blast-furnaces, but, as its little friction would not heat the air like the common blowing cylinder used in blast-furnaces, the objection would be less formidable. Air must doubtless give out some heat by its decrease of volume, just as it will absorb the heat by rarification, as is experienced in exhausting the receiver of an air-pump. The converse of this is equally shown in the little instrument employed to kindle tinder by condensing the air within it.

The heat by the friction of this piston, is probably much more than by the condensation of the air; the latter is obviated in the machine above described, and in another blowing-machine lately introduced, of which we shall give a description.

This machine, in its general appearance, does not seem to have any advantage over the common blowing cylinder, but in practice it is found superior.

It resembles in some degree the common smith's bellows of the Chinese, which consists of a square wooden trunk, in the form of a parallopipedon. A board is made to fit its cross section, pretty nearly, to which is attached a long rod by which the board is pushed backwards and forwards like a piston. At one end of the trunk is a valve opening inwards to admit air, and at the same end is a pipe with a valve opening outwards.

The machine above alluded to having some resemblance to this, is the invention of a Mr Vaughan, who has fitted up several of them for founderies, and which are much approved. The writer of this ar-

ticle has taken a drawing from one of these machines employed to melt cast-iron at the Phoenix Foundry in Sheffield.

Figs. 6. and 7. are two views of the machine. ABCD is a square box formed of pieces of cast metal, screwed together by hinges. Two of these are placed side by side, as may be seen in the end view, fig. 7. MQ is a piston fitting the square box, which is drawn backward and forward by the rod EF, which works horizontally on the wheels wx by the spear G, which communicates with the crank of a wheel at a distance.

The piston MQ, which is the most ingenious part of this machine, is enlarged in fig. 8. to render it clearer. The body of the piston is a cast-iron plate about one-half inch thick, with a socket in the middle to receive the rod. The diameter of this plate is about one-fourth of an inch less than that of the box. Two pieces of wood, $v n$, are cut diagonally, in order to place the pieces of leather, $l l$, between them. These leathers, with the wood, are firmly fastened to the plate by bolts, such as $g h$.

This leather extends about two inches beyond the wood: their slight elasticity keeps them in contact with the metallic surface, which is not required to be very smooth. When the piston moves towards the end of the box, towards which the leather projects, the leather claps close to the surface, rendering it air-tight, while the leather on the other side of the piston becomes loose, and has no friction. These leathers will be contrarily acted upon, when the piston acts the contrary way. The projecting curved pipes, HI, form a communication between the box where the piston works, and the air-chest N. When the piston moves from B to D, the valves F and V open, while L and S are shut. The air contained in the box is now forced through the valve R into the chest N, and from thence along the blast-pipe P.

In the returning stroke, which is the whole length of the box, the valves R, V, and K, are shut, while L and S open. The air is forced through H to N, and then through P.

Two of these work at the same time by two cranks, which cause one to be in full blast at the time the other is returning the stroke; so that, with due management, the four puffs produced by two double strokes may be made to succeed each other at equal intervals, which almost amounts to a steady blast. The inventor recommends four of these boxes all to work together, which would produce eight puffs in the time of one double stroke, which, if divided into equal intervals, would produce a sufficiently uniform blast for any purpose.

When the leathers of the piston are rubbed with black lead, the friction almost amounts to nothing. The leather acts so easy to the surface, and is so flexible, that it may be very easily raised with the fingers. This could not be the case, if it were applied in the same way in a cylinder; and this is a sufficient reason for using the square box instead of the cylinder.

This machine makes 70 strokes in one minute; the nose-pipe, where the blast enters the furnace, is $2\frac{1}{2}$ inches in diameter. When the length of stroke

is the greatest, at the above speed, it furnishes about 1200 cubic feet per minute.

This machine steers clear of the objection of the water, and, from its small friction, will have less tendency to heat the air. Its original cost is also less than any other machine yet constructed. In the situations where it has been adopted, it gives the highest satisfaction. The first construction of Street's bellows, above described, was only fitted for some smiths' fires, where a very soft blast was required. In their improved state they may be employed for most purposes.

All the calculations relative to bellows will be easily made, by the following rules and formula:

First, get the space or capacity formed by one stroke of the machine, call this c , cubic feet.

Then get the number of strokes per minute, which call n .

The area of the nose-pipe, in feet, call (a) .

The pressure on the air to be discharged, whether by a column of water or by a weight, call p .

v = the velocity which the air escapes with.

r = the resistance, in pounds, which the blast will give.

Then $cn = q$ the quantity discharged in one minute; and $v = \frac{cn}{a}$ in one minute, or $= \frac{cn}{60a}$ for one second.

Then since the resistance is equal to a column of the fluid of the area a , and twice the height to

give the velocity, $\frac{v^2 a}{32 \times 14} = p$. The weight of 14 cubic feet of air being equal to 1 lb.

The energy of air in blowing fires, is as the quantity, and inversely as the space it occupies. For if the same quantity of air be consumed in half the space, the intensity of the heat, or the temperature of that particular place, will be double. Hence it is found, that the same quantity of air, by weight, in winter, will produce a greater effect on a blast-furnace than in summer, merely from the difference of density. The great difference in produce of iron in the cold and hot seasons of the year, is a fact notorious with iron masters. (T.)

BOGALCUND, a district of the province of General Gundwana in Hindostan, in the 25th degree of north latitude, and 82d of east longitude; bounded on the west by the British possessions in Bundelcund; on the east by the small territory of Manwas; and watered by the rivers Soane, Bichanuddy, and Behenuddy.

The exact dimensions of this country, so far as we know, are not ascertained, but they appear to be considerable. Part of it is fertile and well cultivated; the chief crops are wheat, barley, and different kinds of pease, all in tolerable quantity: nevertheless, very little grain, exceeding their own necessities, is raised by the natives. They have also numerous herds of black-cattle, and large flocks of sheep. The whole surface is traversed by good roads. Its access from Allahabad, to which it was annexed by Aurengzebe, is by a pass called Sohagee Ghaut, long, steep, and difficult, having at its extremity a redoubt in a strong position. From hence Bogalcund appears

Fig. 6.

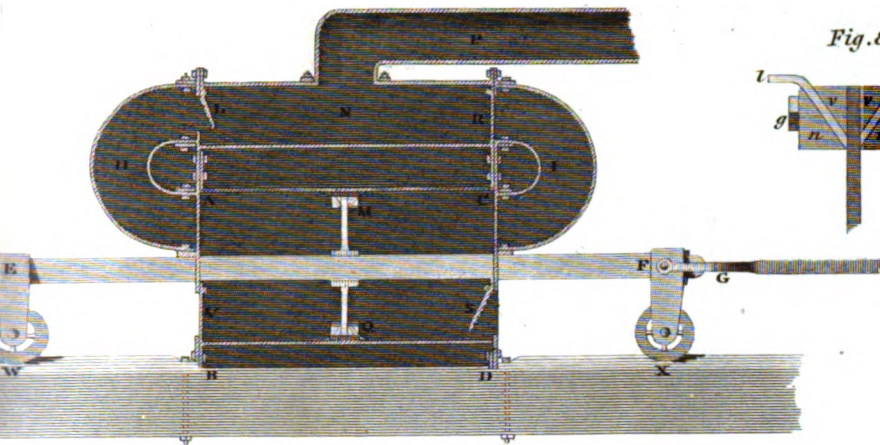

Fig. 8.

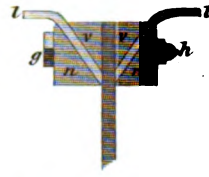

Fig. 7.

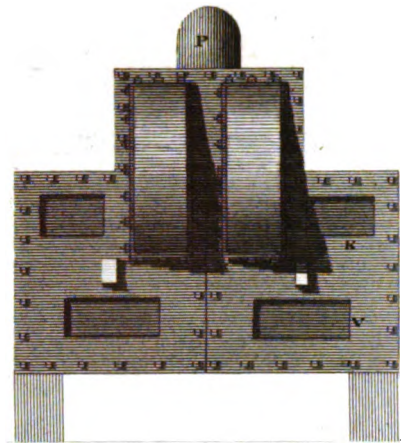

Fig. 1.

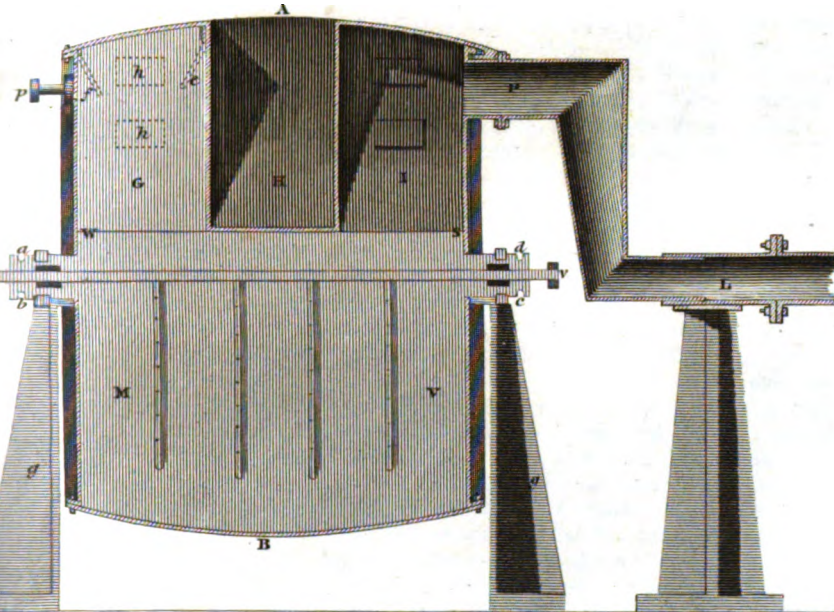

Fig. 2.

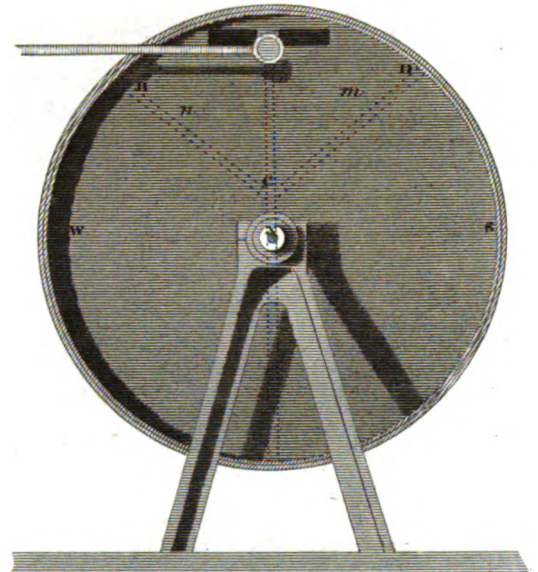

Fig. 3.

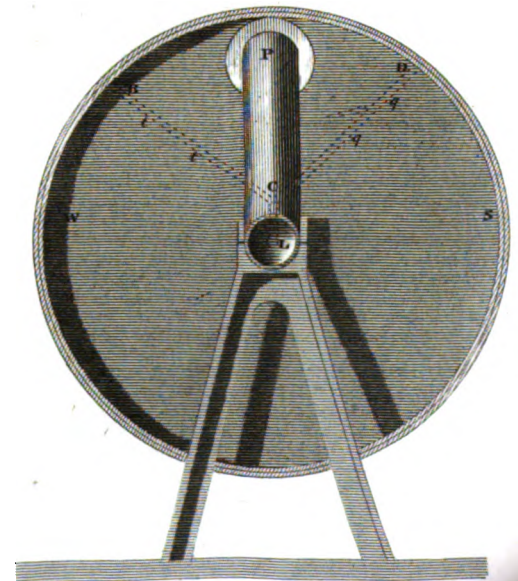

Fig. 4.

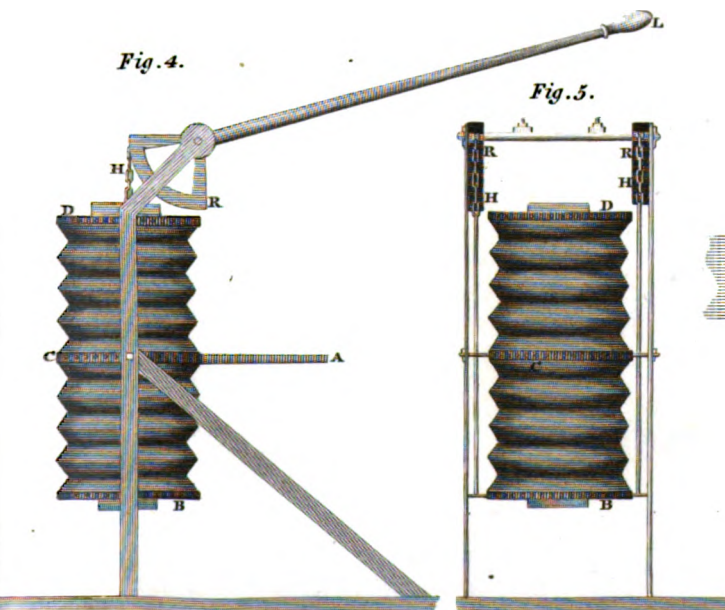

Fig. 5.

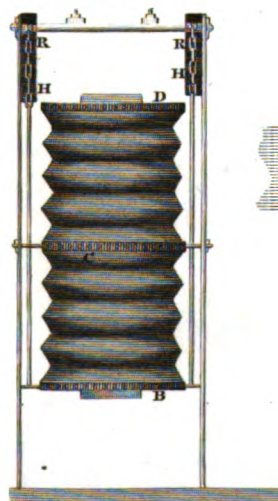

Fig. 9.



Bogalcund like a great table and, without any descent, and the traveller is conducted by a good road to the capital.

Inhabitants. Gundwana is inhabited by various tribes, who seem to receive the generic name of Goands. Their manners and civilization are different, and in various stages of advancement; some, particularly the mountaineers, are rude and savage. They go almost naked, if not entirely so; practise gross superstitions; and dwell in villages consisting of a few huts in places almost inaccessible. But those in the lower and fertile parts of the country are more cultivated, and sufficiently courteous to strangers. The inhabitants of Bogalcund are called Bogals, Bogheleis, or Boghels, synonymes used indifferently; but it is not evident whether they should be considered a distinct race from the Goands of Gundwana. They are reported to have migrated hither from Guzerat many centuries ago, and gradually enlarging their confines by an encroachment on those of their neighbours, expelled a tribe of mountaineers from Shewah, which their chief was induced, by the excellence of its situation, to select for his own residence. It is not unlikely they are of Tartar origin. As this is one of the northern countries of India, whose history and statistics are extremely obscure, very little can be said of the manners, customs, and conditions of its inhabitants. They consist of five different tribes, acknowledging the same government, but without admitting an equal control, or paying the like obedience to it. Part, or the whole, profess the Mahometan religion, and many temples are to be seen in the territory. Three of the tribes follow a practice, too general in the east, of destroying their infant daughters, which must inevitably restrict the population.

The Bogals are skilful in agriculture; and they have many fine tanks, or artificial ponds, conveniences of greater importance in India, and of infinitely greater size than Europeans are wont to conceive. These are generally situate on a declivity, three sides being built up with much art and labour, and the fourth serving as a natural embankment. The agricultural skill of the inhabitants results, in a great measure, from the nature of the government. Here the feudal system prevails, and many of the lands are held by military tenure. The forces have no pay, but, in lieu of it, certain lands are assigned for their subsistence. Their influence is thence very great, and there is not an officer among them without one or two villages for his support. The country is thus partitioned among innumerable feudatories, who find it their interest to promote agriculture in order to provide more amply for their own subsistence. It is common with the peasantry to change their abode at intervals of three or four years, for the purpose of tilling the ground whereon their cottages stood. The traces of villages recently abandoned are, therefore, frequently to be seen, and would indicate declining prosperity, did not their renewal in other places, as often presented to view, prove the reverse.

The chief town of Bogalcund is Rewah, which is large and populous. It is situate on the small river

Bichanuddy, rising twenty miles to the east, and joined by the Behanuddy just above the town. The united stream runs immediately under a large fort in the capital, which includes the houses of the most wealthy and respectable inhabitants, and where the Rajah resides. In the neighbourhood are some memorials of the slain, who lately fell in a great battle, wherein the Bogals were victorious against an invading enemy. Rewah stands in lat. $24^{\circ} 37'$ north, and $81^{\circ} 25'$ east longitude; distant 126 miles north-east of Benares.

This district is under the government of an independent Rajah, who is said to be the Maher-Rajah, or sovereign of several neighbouring territories; and although the Rajah of Bundelcund is himself quite independent, and infinitely the more powerful of the two, it is necessary for him to be invested by the Rajah of Bogalcund, wherein we find another analogy to feudal principles. His revenues are very small, principally owing to the subdivisions of the district; for it has sometimes excited astonishment that the sovereign of so fertile a territory should be so poor. He receives an inconsiderable tribute from the Rajahs acknowledging his superiority, land-rents, and customs on merchandise passing through the capital.

Ali Bahauder, a Mahratta chief who holds a powerful command in the army of the Peshwa, or Head of the nation, threatened Bogalcund with invasion about the year 1794 or 1795, to levy contributions from the Rajah, which he was little enabled to afford. But he was beloved by his subjects, and Ali Bahauder having put his menaces in execution, he raised an army of about 3000 men to oppose him. The enemy advanced with 6000 men, carrying every thing in his course, until arriving within two miles of the capital. There he was encountered, and totally defeated by the Rajah, with the loss of his General and his cannon. The invader vowed to revenge the destruction of this army, and the death of his General. He again collected a powerful force, and invaded Bogalcund a second time, in the year 1795; but the Rajah, then aged and incapable of the exertion necessary to resist so active an enemy, purchased peace by concessions. Either at this time or previously, he engaged to pay Ali Bahauder L. 14,500 Sterling,—a stipulation which he proved totally unable to perform, and a neighbouring Rajah, who had become security for the payment, and required hostages for his indemnification, afterwards obtained the cession of a valuable district in Bogalcund, probably from having been obliged to fulfil his part of the engagement. But this was not the only calamity; for a supervening scarcity in the succeeding season followed the depredations of Ali Bahauder's troops. The natural fertility of the soil, however, and importation of various commodities from Misapour, contributed to relieve the inhabitants, and the country began to recover speedily from the disasters it had been exposed to. Nevertheless, its dismemberment, at no distant period, was anticipated, from the growing poverty and declining power of the Rajah, though the nature of the soil, and the state of agriculture, were both suf-

Bogalcund sufficient to support a numerous population. Formerly, the influence of the Rajahs of Bogalcund was very considerable in Indian affairs, and they have been known to afford an asylum to powerful Princes, whom temporary adversity exiled from their own dominions. Here the illustrious Emperor of the Moguls, Ackber, was born in the year 1542. On occasion of a usurpation of the empire, his father, Humayoon, retired from Delhi; and his mother, when pregnant, was, for greater security, sent to a strong fortress, where, tradition reports, she was almost immediately taken in labour. But the Astrologers of the day having previously determined that future felicity would attend the child who should be born at a certain moment, she was suspended, during two hours, by the legs, in order to retard the period of delivery, and then being taken down, the great Ackber saw the light. More recently, when his descendant, Shah Aulum, was dispossessed of the throne of Delhi, in the course of last century, by the invasion of another potentate, he sought refuge with Ajet Sing, the Rajah, of whom we have already spoke; and here, also, between the years 1750 and 1760, one of his wives was delivered of a prince, whom she called Aekber, in commemoration of his ancestor, and who lately survived at the capital, Delhi, which was restored to him. But the future greatness of the latter Prince being of less importance, his mother probably escaped the cruel experiment to which the parent of Ackber was subjected. (s.)

BOHADDIN, or, more properly, BOH-A-EDDYN, an eminent Arabian Writer and Statesman; is better known in the East under the appellation of Ibn-Sjeddad, the son of Sjeddad. He was born at Mossul, in the year 539 of the Hegira. (1145 A. D.) He early became eminent in the study of the Koran, and of the traditions and controversies founded on it, as well as that of Jurisprudence. At twenty-seven, he obtained the place of Repeater or Lecturer at Bagdad; and, soon after, a Professor's chair, in a College, founded at Mossul. In 1187, he made the pilgrimage to Mecca, and then proceeded to visit Jerusalem and Hebron. In passing through Damascus, he was sent for by Saladin, who was then employed in the siege of Kancab. The Sultan seems to have been pleased with the interview; and, his Secretary Omad-Eddyn-Isfahamy, a man of great learning and eloquence, advised him, after completing his pilgrimage, to present himself again before Saladin. Our author had observed, as he himself mentions (*Vita Saladin*, ch. v.), that the whole soul of the Monarch was engrossed by the war which he was then waging against the enemies of the faith; and, that the only mode of acquiring his favour was, by urging him to its vigorous prosecution. He, therefore, composed a treatise on the *Laws and Discipline of Sacred War*; and made a collection of all the passages in the Koran and the books of traditions, in which, the extermination of infidels was recommended and enforced. This work, on his return, he presented to Saladin, who received both it and the author with peculiar favour. Bohaddin, from this time, remain-

ed constantly attached to the person of the Sultan, and was employed in various important embassies and departments of civil government. That Prince seems also to have sought, by the friendship of so eminent a doctor, to exalt the reputation for sanctity, of which he was extremely ambitious. Often while riding through the ranks, Bohaddin rode by his side, and read to him passages out of the Koran or its interpreters, to which Saladin lent more apparent attention than to the arrangements of the army. Our author was now appointed to two important posts; those of Judge of the Army, and Judge of Jerusalem. In this latter capacity, an incident occurred, which he adduces to prove the impartial justice exercised by the Sultan. A merchant presented himself at the tribunal of Bohaddin, and complained, that he had been unjustly deprived of a large sum of money. On being asked the author of the injury, he replied, "the Sultan himself." Here the Judge deemed it expedient to suspend proceedings, until the case was laid before the royal defendant. Saladin, on learning the circumstances, denied the truth of the charge; but said, that the man should have justice. Accordingly, he was introduced into his presence; the Sultan descending from his throne, placed himself in the posture of a defendant; and each pleaded his own cause before Bohaddin. The latter decided (on just grounds as he alleges) in favour of Saladin; and even hinted, that the temerity of the plaintiff merited some portion of chastisement. The Sultan, however, dismissed the person not only unpunished, but with the present of a handsome robe, and a large sum of money.

Bohaddin continued in favour with Saladin during the whole of that Monarch's life, and boasts, that he often obtained ready admission, while the principal officers and generals were waiting in vain for an audience. After the Sultan's death, he was active in securing the throne to his son, Melik-al-Dhaker. That prince created him Cadhi of his capital, Aleppo, which gave Bohaddin an opportunity of founding in that city a College, of which he himself was the principal Professor. Under his auspices, the sciences, which had greatly declined in Aleppo, soon rose to more than their former lustre. Melik-al-Dhaker dying, left his son, Melik-al-Aziz, a minor, and Bohaddin obtained the principal sway in the Regency. This gave him an opportunity of introducing learned men at court, and loading them with honours. As the prince, however, approached to manhood, he attached himself to more youthful counsellors; Bohaddin, then, though he still retained his offices, found it expedient to retire from court, and devote himself entirely to the pursuits of learning. Even after he was unable to go to college, he continued to give lectures in his own house; and he persevered in these learned labours till the age of ninety, when he died, on the 29th October 1235. (Hegira 633.)

Bohaddin wrote several works on Jurisprudence and Moslem Divinity; but, the only one that can be interesting to us is his *Life and Actions of Saladin*; which, with several other pieces connected with the

Bohaddin same subject, was published by Albert Schultens, at Leyden, in 1732, accompanied by a somewhat inelegant Latin translation; also by notes, and a Geographical Index. This work affords a favourable specimen of the historical compositions of the Arabs. Neither Bohaddin, however, nor any of his contemporaries, can enter into competition with those great historians, who have adorned the better ages of European literature. They display no philosophical views nor accurate discrimination of character; but confine themselves chiefly to a mere chronological record of events. The work of Bohaddin is written with some spirit, and, at the same time, is free from that verbose and empty inflation which deforms the composition of some of his contemporaries. Whatever relates to Saladin, breathes, of course, the highest tone of panegyric; yet, the enthusiasm with which every thing about him is narrated, and the anecdotes which the author, from his own personal knowledge, is able to communicate respecting that extraordinary character, give his work a great degree of interest. (A.)

BOMBAY. The account of Bombay in the *Encyclopædia*, contains several interesting particulars relative to its soil, climate, and the manners of its inhabitants, and we propose, in the present article, to add such farther information as we have collected from the works of recent observers.

Island.

The Island of Bombay, which is the seat of Government for the western part of India, is situated in lat. 18° 56' N. and lon. 72° 56' E. Its length, from north to south, is 6½ miles, and its breadth, near the fort, is about a mile. It is separated from the mainland by an arm of the sea, and it forms, in conjunction with the adjacent islands of Colabah, Salsette, Butcher's Island, Elephanta, and Caranjah, a large, commodious, and well sheltered harbour. The north side of the harbour is partly formed by the Island of Colabah, which is separated from Bombay by a small creek, fordable at low water, and is about 2½ miles long. Near its southern extremity stands the light-house,—a building of a circular form, rising from the sea to the height of 150 feet, and shewing its light at the distance of 21 miles. The Island of Salsette, which is about 20 miles long and 15 broad, is separated from Bombay by a narrow arm of the sea. Over this strait a causeway was constructed in 1805, which, by improving the communication with the mainland, is of infinite service to the surrounding country, with the produce of which Bombay is supplied; but it is said to have had a prejudicial effect on the harbour. Butcher's Island is nearly opposite to Bombay Castle, at the distance of three miles; and about two miles from this, and still fronting the fort, is the inconsiderable, but celebrated, Island of Elephanta. The two small Islands of Henery and Kenery, lie at the entrance of the harbour.

Town of Bombay.

The town of Bombay is nearly a mile in length, from the Apollo Gate to that of the Bazar, and about a quarter of a mile broad in the widest part, from the Custom-house across the green to Church Gate, which is nearly in the centre, between the Apollo and the Bazar Gates. There are likewise two gates towards the sea, having commodious

wharfs, and cranes built out from each, with a landing-place for passengers. Between these gates is Bombay Castle,—a regular quadrangle, built of hard and durable stone, and having the advantage, in one of the bastions, of a large reservoir of water. The fortifications are numerous, and they have been improved in proportion as the place has risen into greater importance from its increasing trade. They have lately received a considerable accession of strength from Dunganee Hill, which commanded the town, having been included within the fort; and towards the sea they are extremely strong, the harbour being completely commanded by ranges of batteries placed one above another. But on the land side, its means of resistance are not so formidable; nor is this of much moment, as an enemy once landed, would find no difficulty in possessing himself of the place. A bombardment would, in a few hours, lay the town in ashes; and were the houses, which are lofty and made of combustible materials, once on fire, the troops could no longer preserve their station on the ramparts. Indeed, it is probable, that the destruction of the magazines would be the consequence of the conflagration of the adjacent buildings.

In the centre of the town is a large open space, called the Green, around which are many large and well-built handsome houses. Here is also the church, which has an extremely neat and light appearance; and, on the left of the church-gate is the Government-house, which is a showy edifice, but liable to the inconvenience of having the largest apartments in both floors a passage-room to the others. On the right of the church-gate is the Bazar, which is crowded and populous. Here the native merchants reside, and at the entrance to the street stands the Theatre, which is a handsome building. In the year 1803, this part of the town was greatly injured by a destructive fire, which destroyed nearly three-fourths of the Bazar, together with the barracks, custom-house, and many other public buildings, besides property of immense value belonging to native merchants. The flames spread with such rapidity, that the magazine was endangered; and, in order to preserve the town from total destruction, many houses in the neighbourhood of the castle were battered down with artillery. Since this period, the town has been rebuilt on an improved plan, at the expence of the Company.

Bombay is the only principal settlement in India where the rise of the tides is sufficient to admit the construction of docks on a great scale. The highest spring tides rise to the height of 17 feet, and the height of the ordinary tides is 14 feet. In consequence of these natural advantages, the dry-dock of Bombay has scarce its equal for size and convenience; having three divisions, with a pair of strong gates to each, so that it is capable of receiving three ships of the line at the same time. Near this dock is a convenient place to heave down several ships at once, and this operation is well executed, and with great expedition, by the Persees, who are generally accounted excellent ship-carpenters. Here is an excellent rope-walk, equal to any in England, with the exception of the King's yard at Portsmouth,

Y. Y.

Bombay. where cables and all sorts of lesser cordage are manufactured. It has also a covering, to protect the workmen from the heat or inclemency of the weather. The dock-yard is large and well contrived, having ample supplies of naval stores deposited in the warehouses, together with large quantities of timber, for repairing and building ships, and forges for all kinds of smith's work. With all these advantages, Bombay claims a distinguished rank as a naval arsenal, and within these few years many merchant ships of from 600 to 1300 tons, partly for the country trade and partly for the service of the Company, have been built in its docks, which, in beauty of construction, good workmanship, and durability, are superior to any other class of merchant ships in the world. Bombay is the only port in any of the British possessions out of Europe at which a ship of the line was ever built; and it deserves to be recorded that the *Minden*, a 74 gun-ship, was launched from its dock-yards in 1810. It has also added several frigates to the British navy. All these vessels are built of Malabar teak, which is esteemed superior to any in India. The Teak forests, from which supplies of wood are derived, lie along the western side of the Ghaut mountains, and other contiguous ridges on the north and east of Basseen; the numerous streams which descend from them affording water-carriage for the timber. The docks belong to the Company, and the King's ships pay a monthly rent for repairs. They are entirely occupied by *Persees*, who are esteemed remarkably skillful and assiduous. Bombay, thus possessing, in the skill of its workmen, the excellence of its timber, and the superiority of its docks, all that is necessary for a naval arsenal, may be considered as a station of the first importance to the British power in India.

Commerce. From its position, Bombay commands an extensive commerce with the countries situate in the Persian and Arabian gulfs, and with the western coast of India. It carries on, also, a valuable trade with the eastern parts of India, the Islands in the eastern ocean, and with China. Of the trade with China, the staple commodity is cotton-wool. The other articles consist of sandal-wood and pepper, the produce of Malabar and other adjacent countries; gums, drugs, and pearls, from Arabia, Abyssinia, and Persia; elephants' teeth, cornelians, and other produce of Cambay; sharks' fins, birds' nests, and other articles from the Maldivé and Lackadive Islands. The ships generally arrive at Canton in June or July, and lie there until December or January. In 1808, the quantity of cotton brought to Bombay for re-exportation amounted to 85,000 bales, of 375 pounds each, which is partly procured from the country on the Nerbuddah, and from Gujrat and Cutch. The quantity, however, is not usually so large; and in this trade, Bombay has been lately rivalled by the competition of the merchants of

Bombay. Bengal and Madras, who, having adopted a different method of cleaning their cotton, have sold it to greater advantage in the market of Canton than the merchants of Bombay; and unless the latter adopt the same method of preparing their commodity, it is probable that this lucrative branch of trade will decline. It is about thirty-five or forty years since the cotton-trade from Bombay to China was first established. At that period, a great scarcity of provisions having occurred in China, the cultivation of cotton was restricted by an edict of the government, and grain was ordered to be raised in its stead. Hence a great demand arose in the Chinese market for cotton, which has continued ever since to increase. But the general inattention of the Bombay merchants to the quality of the commodity, and the many frauds which have been practised upon the Chinese, have induced them to resume the cultivation of cotton, for the purpose of having within themselves the necessary supply of this useful article. On this account the demand from China may be rather considered as precarious. In stowing and packing the cotton, great dexterity is displayed. It is pressed down by means of a screw, worked by a capstan, to each bar of which there are 30 men, amounting on the whole to 240 to each screw. Hemp is packed in the same manner, but it requires to be carefully laid in the press; its fibres being liable to be broken if they are bent.

Bombay carries on a considerable trade with Europe, and with different parts of America. The imports from Europe are principally articles for the use of the natives and Europeans; consisting mostly of the finer articles of European manufacture; the produce of other countries for re-exportation, piece goods, and treasure. The value of goods imported from London, from May 1811 to April 1812, was 20,58,942 rupees, equal to L. 231,630. The value of the following exports to London, during the same period, was 15,37,800 rupees, equal to L. 173,000, viz.

	<i>Sicca Rupees.</i>
Surat manufactures	3,183
Produce of Madeira	39,880
———— Mozambique	15,834
———— Bengal	62,957
———— Penang and Eastwards	54,142
———— Malabar and Canara	81,169
———— Persian Gulf	14,678
———— Arabian Gulf	4,01,603
———— Cashmere	12,683
———— Gujrat	49,450
———— Piece-goods	1,10,650
	<hr/>
	9,41,282
Treasure	5,89,018
Horses	7,500
	<hr/>
	15,37,800*

* A Lack is 100,000, which, at 2s. 3d. per rupee, is L.50,000 Sterling. When any sum amounts to more than 100,000 rupees, the usual mode of numeration is to divide the lacks from the remaining part of the sum, thus, 15,37,800, which is 15 lacks, thirty-seven thousand eight hundred rupees.

Bombay.

Bombay.

The following is a TABLE of the estimated Value in Rupees of the Exports and Imports to and from other places.

Imports.	Sicca Rupees.	Exports.	Sicca Rupees.
From Madeira	70,360	To Brasils	43,334
From Brasils (of which there was treasure to the amount of 13,57,650)	15,18,400	To the Isle of France	2,63,403
From the Isle of France, of which cloves composed two-thirds	5,34,183	To China	37,17,522
From China, consisting of articles for the use of the natives and Europeans, manufactures, piece-goods, treasure	40,64,654	To Manilla	78,837
From Manilla, half of which consisted of sugar	2,29,350	To Pegu	6,458
From Pegu		To Prince of Wales Island	7,54,560
From Prince of Wales Island, and the Islands to the Eastward	4,99,886	To Bengal	4,25,615
From Bengal, consisting of raw silk, piece-goods, sugar, groceries, grain	27,70,051	To Coast of Coromandel	1,87,464
From the Coast of Coromandel	80,771	To Ceylon	67,048
From Ceylon	1,14,331	To Malabar	17,66,193
From Malabar and Canara, grain, manufactures, piece-goods	30,01,139	To Goa and Concan, consisting generally of the produce imported from other countries	51,29,222
From Goa and the Concan, grain, manufactures, piece-goods	20,40,364	To Bassein, &c.	2,96,179
From Bassein and adjacent villages	3,63,682	To Cutch and Sinde, consisting chiefly of Chinese goods	11,11,227
From Cutch and Sinde	3,26,668	To the Persian Gulf, merchandise imported from other countries	19,48,205
From Persian Gulf, grain, manufactures, piece-goods, treasure, horses	21,40,740	To the Arabian Gulf, merchandise and European goods	3,64,731
From Arabian Gulf, merchandise, treasure, horses	9,44,292	To the East coast of Africa	46,449
From East coast of Africa	1,37,386	To Surat, manufactures of other countries, treasure	19,07,032
From Surat, grain, manufactures, piece-goods, treasure	10,30,336	To Gujrat	39,53,572
From Gujrat, &c. piece-goods, treasure,	51,11,696		
The whole value of the imports for 1811-12, amounted to	16,970,626	The whole value of exports, for 1811-12,	
Treasure	3,737,084	Merchandise	14,550,642
Horses	239,875	Treasure	3,027,963
	20,947,585	Horses	229,473
		Rupees	17,808,100

In pounds Sterling, these imports amount to L.2,356,603

In pounds Sterling, these exports amount to L.2,003,411

Inhabitants. Bombay is estimated to contain 220,000 inhabitants, of whom nearly three-fourths are Hindoos. The other fourth is composed of persons from almost every Asiatic nation. The number of Persees is estimated at 8000, there is nearly the same number of Mahometans, and there are 4000 Jews. The Portuguese are also to be found in considerable numbers. The Persees rank next to the Europeans, and carry on, many of them, extensive commercial transactions. They are the brokers and factors of Europeans, and have a concern in most of the foreign speculations of European mercantile houses. They are a rich, industrious, and active body of men, and contribute greatly to the prosperity of the settlement, and are treated by the government with great favour and indulgence. For the protection which they enjoy, they are exceedingly grateful, and openly express their conviction that they could not

obtain the same advantages in any other part of the East. They are the descendants of the ancient Persians, who fled from the persecution of Shah Abbas in the sixteenth century, when he expelled the worshippers of fire from his dominions, and compelled them to seek an asylum in other countries. The Persees at Bombay appear to be quite domesticated in their new residence, in which they have purchased valuable properties. Besides the Persees, many considerable Portuguese, American, and Hindoo merchants reside at Bombay, who have acquired valuable property, and have the reputation of great integrity. There are likewise some Bonah merchants, or Mahometan Jews, who carry on a great trade with Guzzerat, and other places to the northward. All those different classes of inhabitants live happily together, and enjoy great prosperity under the mild and equitable rule of the British government.

Bombay. The Company's naval force at Bombay consists of fifteen fighting vessels, besides armed boats, advice-boats, and other craft; and to man this navy, a regular establishment of officers and seamen is maintained. The western coast of India, from the shores of the Persian Gulf to Goa, is infested by swarms of pirates, who are distinguished, particularly those in the northerly tracks, by courage, address, and by habits of extreme ferocity. It is to protect the country trade against the depredations of these banditti, who have haunted those seas since the time of Alexander the Great, that the Company finds it necessary to maintain this naval force. Out of 104 marine covenanted servants of the Company, Bombay employs 93.

Company's Naval Force.

Army. In 1811, the regular army of the Company at Bombay, including all descriptions of force, amounted to 20,988 men. The officers amounted in number to 549, and their pay and allowances to L. 171,450. In the same year, the civil servants of the Company on the Bombay establishment, amounted to 74, and their pay and allowances to L. 174,238.

Productions of the Island. The Island of Bombay scarcely produces any articles of food, which have to be imported from various parts of India, and which are consequently much dearer here than in the other presidencies. Considerable quantities of rice and other grain are annually imported. The prices are continually fluctuating, from the state of the market, which is under the superintendence of the police. Potatoes, which, though recently introduced, are now produced in the greatest abundance in this quarter of India, are brought to the Bombay market from Gujrat, from which also is procured cheese, which is hard and ill-flavoured. The only vegetable for which Bombay is celebrated is the onion, which is esteemed excellent. All other vegetables are scarce and dear.

The Bazar mutton is, when well fed, thought to be as good as the English. Kid is always good, and there is abundance of poultry, which is not good, however, unless it is fed on purpose. The fish are excellent, but those of a larger size are not plentiful. The prawns are uncommonly fine; and though the Island is too small to furnish great abundance of game, the red-legged partridge is not uncommon, and snipes are sometimes seen. The frogs here are large, and are sometimes eaten by the Chinese and Portuguese.

Court of Justice. A court of justice is held at Bombay by a single Judge, with the title of Recorder. Its cognizance extends to all British subjects, and generally to all the inhabitants of Bombay. But it is allowed no cognizance over the land revenue. The Judge is directed, in all suits to which the natives are parties, to respect the usages of the country, and in matters of inheritance or contract, the law acknowledged by the respective litigants is to be the rule of decision. Criminal offences are tried by a jury, consisting exclusively of British subjects. The law practitioners of this court are three barristers, and eight attorneys.

Buildings. The same passion for country-houses prevails at Bombay as at Madras. These houses are generally comfortable and elegant; and if they have not the splendid Grecian porticos of Calcutta and Madras,

they seem to be better adapted to the climate, and have the advantage of the most beautiful and picturesque views; the Island of Bombay being broken by several beautiful hills, either covered with coconut tree groves, or villas of the inhabitants. The only English church in Bombay is in the fort. There are numbers of Portuguese and Armenian churches both within and without the walls, and there are three or four synagogues, with many temples and mosques.

Climate. Bombay, from its situation, might be supposed to be healthy, but this is said not to be the case; the liver complaint being more fatal and frequent here than in any part of India. A land breeze sets in every evening, which is described as being peculiarly noxious, and is frequently followed by a fever, and by a loss of the use of the limbs. This breeze is mentioned by Lord Valentia, to have been chillingly cold at the time he visited Bombay. But he attributes its deleterious effects not merely to this cause, but to the noxious vapours with which it is tainted in its passage over the rank vegetation which springs up in the marshy parts of the bay immediately after the rains. Moderate living affords the best security for health; the extremes of intemperance and over abstemiousness being equally injurious.

The travelling distance from Bombay to Calcutta is 1800 miles; to Delhi 965; to Hyderabad 480; to Madras 770; to Poonah 98; to Seringapatam 620; and to Surat 177 miles.

History and Settlement. Bombay was first settled by the Portuguese, to whom it was ceded in 1530; having been before dependent on one of the native chiefs. In 1661, it was ceded by the Crown of Portugal in full sovereignty to Charles II. by the treaty of marriage concluded with that power, when he espoused the Infanta. In order to take advantage of this acquisition, and to make it a profitable dependence on the Crown, a fleet was dispatched under the command of the Earl of Marlborough in 1662, to receive formal possession of the Island and its dependencies. Some doubts arising, however, as to the construction of the treaty, the Viceroy refused to surrender the Island, on which the Earl of Marlborough returned to Europe, after having left the troops, amounting to 500 men, in the Island, where most of them died. In 1664 a treaty was concluded by this nobleman's successor with the Viceroy of Goa, in which the former renounced all pretensions to the dependencies of Bombay, and accepted of the cession of the Island alone, which the English accordingly received in 1665; the troops who had survived the ravages of disease, only mustering 119 rank and file.

It was soon discovered that the revenues of the Island were not equal to the expence of retaining it, and that the East India Company were much injured by a contraband trade carried on by persons in the King's service. In consequence of these and other reasons, the sovereignty of the Island was, in 1688, transferred to the East India Company. The Company's servants made every exertion to place this new acquisition in a respectable state of defence, and to encourage settlers; and, in 1675, the Island of Bombay, from being almost a desert, had become the centre of the Company's trade, protected by fortifications with 100 pieces of cannon mounted, and a suit-

Bombay. able garrison. In 1676 letters-patent were obtained from the King to establish a mint at Bombay, at which they were empowered to coin rupees, and other smaller pieces. At this period Bombay continued to be of very little importance, which partly proceeded from the vigorous government of Aurangzebe, and the rising power of the Mahrattas. These two powers contended for the possession of the Island of Kener, which was seized on by the troops of both, the Bombay government not daring to oppose either party, but trembling for its own safety amid these formidable contentions. Bombay was soon afterwards, in consequence of the capture of Bantam by the Dutch, constituted an independent English settlement, and the seat of the English power in the East Indies.

In 1678, the Company, finding it necessary to retrench the expences of the establishment, proceeded to reduce the salaries and to lower the rank of their military officers, which produced general discontent, and, finally, a serious revolt, which threatened the most alarming consequences to the Company's affairs. This insurrection was headed by Captain Richard Reigwin, Commander of the Garrison, who seized the Governor and such members of the council as still adhered to him, and having assembled the troops and militia, annulled the authority of the Company by proclamation, requiring the inhabitants to renounce obedience to their authority, and to take the oaths of allegiance to the King. The whole inhabitants and all the troops immediately complied with the terms of this proclamation; and all the exertions of the Governor of Surat to persuade the revolted to return to their duty were in vain. The mutiny was at length quelled by the prudence of Sir Thomas Grantham, who arrived from Surat with a commission from the King, and had a conference with Reigwin, in the course of which the latter agreed to deliver up the fort, on condition of receiving a free pardon for himself and his associates.

Since this period, the settlement of the English East India Company at Bombay, has been frequently in a very precarious condition, sometimes from the unhealthiness of the climate, and, at other times, from the jealousy of the native powers. But, after the power of the Company became more firmly rooted in India, it has continued gradually increasing in wealth and consequence, and may now be accounted one of the most important and durable possessions of the British in India.

The Government of Bombay and its dependencies, is by law vested in a Governor and three Counsellors, who are placed under the control of the supreme government of Bengal, and are in all cases to obey such orders as they may receive, provided they have no different instructions in their possession from the Court of Directors, of which they are bound to send immediate notice to the Bengal Government. The Court of Directors appoint the Governor and members of the Council, and likewise the Commander in Chief of the forces, who is not officially a member of the Council, but may receive such an appointment from the Directors, and, in that case, he takes precedence of all the other members.

It is difficult to fix with precision the extent of the territories included within the Presidency of Bombay,

as some districts belonging to the native powers are intermingled with them. On a general estimate, however, they may be calculated to comprehend 10;000 square miles, and to contain a population exceeding altogether two millions and a half, which may be supposed to consist of one Mahometan to fifteen Hindoos. Of the Persees no exact estimate has ever been made.—See Milburn's *Oriental Commerce. Voyages and Travels* of Lord Valentia. Hamilton's *East India Gazetteer*. (o.)

BORDA (JOHN CHARLES), a Mathematician and Nautical Astronomer, celebrated for his improvements in the theory of Hydraulics and Pneumatics, and in the construction of instruments for observation. He was born at Drax, the 4th of May 1733, and was originally destined for the bar, but abandoned the pursuit of the law in favour of a military life, which he considered as better calculated to afford him opportunities for the cultivation of his mathematical talents, and, for the application of the results of his studies to practice. His acquirements in science had very early attracted the attention of D'Alembert, who predicted his future eminence, and warmly recommended his turning his thoughts to the occupation of a place in the Academy. He obtained a commission in the Light Cavalry, and was appointed Teacher of Mathematics to the corps; and, in 1756, he presented to the Academy of Sciences (A.) *A Memoir on the Paths of Bombs*, which was ordered to be printed in the collection of the *Savans Etrangers*, but which has not excited much attention. He was elected in the same year a member of the Academy; and in the next he was present at the battle of Hastinbeck, in the capacity of Aide-de-Camp to the celebrated General Maillebois, to whom he looked up as a great master in the art of War.

He was afterwards admitted into the corps of Engineers, without the usual form of examination into his qualifications; and, being stationed at a seaport, the occurrences of the place naturally directed his attention anew to the phenomena of the resistance of fluids. He published, in 1763, a detailed memoir on this subject (*B. Mém. Ac. Par.* 1763, p. 358), in which he relates a variety of experiments, showing, that the resistance of the air is actually proportional to the square of the velocity, as had commonly been supposed from theoretical considerations. He also determines, by other experiments, the magnitude of the resistance to the motion of a sphere, and proves, that nothing can be more erroneous than the supposition, that the resistance to an oblique surface decreases as the square of the sine of the angle of incidence. He also finds, that the resistance to the motion of a cube, in the directions of the diagonal of its base and of one of the sides, are as 21 to 16, while the calculations of former theorists had made the resistance greatest in the direction of the side.

In 1766, he published an Essay on the discharge of fluids through the orifices of vessels (*C. Mém. Ac. Par.* 1766, p. 579), in which he first states the objections to considering the different strata of a fluid as descending in all cases very nearly in parallel directions; he examines the contraction of the jet after its escape from the orifice, and determines some

Bombay
Borda.

Borda.

of the effects of abrupt changes in the velocity of the fluid passing through pipes or apertures of different forms.

He contributed, in 1767, to the publications of the Academy, an important *Memoir on Water Wheels* (D. p. 270), which has escaped the notice of his able Biographer M. Lacroix. He observes, in this paper, that the simple hypothesis of a resistance varying as the square of the velocity, which is so near the truth in common cases, where a number of particles, proportional to the velocity, strikes, in a given time, upon a small exposed surface with a force also proportional to the velocity, is totally inapplicable to the action of a confined stream upon the floatboards of a wheel, since, in this instance, the number of particles concerned cannot vary materially with the velocity, the whole stream being supposed to operate in all cases upon the successive floatboards; so that the analogy would require us to suppose the force in this case nearly proportional to the simple relative velocity; a conclusion which agrees remarkably well with the experiments of some practical authors.

The same volume contains a continuation of M. Borda's researches relating to the resistance of oblique surfaces (E. *Mém. Ac. Par.* 1767, p. 495), with a statement of experiments still more conclusively confuting the received hypothesis, respecting oblique impulse, than his former investigations had done. We also find in it an Essay on isoperimetrical problems (F. p. 551), in which it is shown, that Euler's method of treating them, which had been in great measure abandoned by its equally profound and candid author, in favour of the more general and more elegant calculations of Lagrange, was still capable of affording all the results that had been derived from the method of variations; and he even pointed out some deficiencies in the first Memoir of Lagrange, which contained the detail of his ingenious invention. These investigations of M. Borda afford collateral evidence of the strict truth of the demonstrations of both his great predecessors; and though they have been little employed by later Mathematicians, yet it must be admitted to be of some importance, in enabling us to appreciate the value of a new mode of calculation, to determine whether its results are or are not such, as might be obtained, with almost equal convenience, by methods before in use.

His memoir, inserted in the collection of the Academy for 1768 (G. *Mém. Ac. Par.* 1738, p. 418), is devoted exclusively to the theory of pumps; and he considers especially the effect of the passage of the fluid through valves and other contracted parts, in diminishing the quantity of the discharge. His results are derived from the principle of the preservation of the living force or energy of a system of bodies, throughout all the vicissitudes of its motions, which had before been employed with success by Daniel Bernoulli in problems of a similar nature; but it was not until the experiments of Buat had afforded sufficient grounds for the determination of the friction of fluids, that cases of this kind could be submitted to exact calculation.

In his Essay on the curve described by cannonballs, published among the Memoirs for 1769 (H. *Mém. Ac. Par.* 1769, p. 247), he has greatly simpli-

Borda.

fied the practical theory of projectiles, which had been treated in a satisfactory, though very general manner by John Bernoulli, and had been reduced into a much more convenient form by Euler. M. Borda has substituted some approximate expressions for the true value of the density of the air, and has thus been enabled to integrate equations which, in their more strictly correct form, had resisted the powers of Euler himself; and he has justified the adoption of the formulas thus obtained by a comparison with experiment.

In the meantime his talents were very actively employed in the naval service of his country, which he entered in 1767, by the nomination of M. Praslin. The time-keepers of Le Roy and Berthoud were beginning to rival those of the English artists, and the French Government ordered several vessels to be fitted out for cruises, in order to examine the accuracy of these time-keepers. M. Borda was appointed a Lieutenant on board of the *Flore*, and acted jointly with M. Pingré as a delegate of the Academy of Sciences for the purposes of the expedition. The voyage occupied about a year, and extended to the Canaries, the West Indies, Newfoundland, Iceland, and Denmark. M. Borda had a considerable share in the account which was published of the observations; and the formula, which he has here given, for the correction of the effects of refraction and parallax, is considered as equally elegant and convenient. He also presented to the Academy a separate Memoir on the results of the expedition. (*l. Voyage pour éprouver les montres de Leroy. 4. Paris.* (K. *Mém. Ac. Par.* 1773, p. 258.) After an interval of six weeks, these watches were found capable of determining the longitude within about fifteen minutes of the truth.

In order to supply some deficiencies in the observations made at the Canaries, Borda was sent out a second time, with the *Boussole* and the *Espiegle*, and he published, after his return, (L.) a very correct and highly finished map of these islands. He was soon afterwards promoted to the rank of Captain, and served under the Count d'Estaing as a Major-General, an appointment nearly similar to that of our Captains of the fleet. In this capacity, he observed the inconvenience of too great a variety in the sizes of the vessels constituting a fleet, and proposed to abolish the class of 50 and of 64 gun ships, as too small for the line of battle, and to build ships of three rates only, the lowest carrying 74 guns, so that a smaller quantity of stores should require to be kept ready for use in the dock-yards, than when ships of more various dimensions were to be refitted. In 1780, he had the command of the *Guerrier*, and in 1781 of the *Solitaire*, which was taken, after a gallant resistance, by an English squadron. He was thus compelled to pay a visit to Great Britain, but was immediately set at liberty upon his parole.

He proposed to the Academy in this year (M. *Mém. Ac. Par.* 1781), a mode of regulating elections, which was adopted by that body. Its peculiarity consisted in having the names of the candidates arranged by each voter in a certain order, and collecting the numbers expressing the degrees of preference into separate results, so that the simple majority of voters did not necessarily establish the

Borda. claim of any individual, if he was placed very low in the list by any considerable number of those who voted against him. But, it must be allowed, that this mode of election is by no means wholly objectionable.

M. Borda appears to have rendered an essential service to the cultivators of Practical Astronomy, by the introduction and improvement of the repeating circle, although this instrument has probably been less employed in Great Britain than elsewhere, on account of the greater perfection of those which were previously in common use. It had been suggested by Mayer, in 1767, that a circle with two moveable sights, would enable us to observe a given angle a great number of times in succession, and to add together the results, without any error in reading them off, and thus to obtain a degree of precision equal to that of much larger and better instruments of a different construction; but the proposal had been little noticed until ten years afterwards, when Borda pursued the path pointed out by Mayer, and trained Lenoir, then a young and unlicensed artist, to the execution of the improved instrument, notwithstanding the opposition of the rival opticians, and the want of encouragement from the opulent public. He published, in 1787 (N.) his *Description and Use of the Reflecting Circle, with different Methods for Calculating the Principal Observations of Nautical Astronomy*; but the officers of the French navy, for whom this work was intended, appear to have profited but little by his instructions. His instrument was, however, much employed in the operations for determining the length of the terrestrial meridian, and he himself took charge of the experiments required for ascertaining the length of the pendulum, and for the comparison of the different standards with each other. He invented some very ingenious methods of overcoming the difficulties which present themselves in the pursuit of these objects; but he was interrupted in his researches by the horrors of the Revolution, nor did he live to see the whole of the operations completed. He endeavoured, also, to promote the introduction of the new mode of subdividing the circle, by the laborious computation of *Tables of Logarithms* (O. 4to, Par. 1801), adapted to decimal parts of the quadrant,—a work in which he was assisted by M. Delambre. From the increasing indisposition of M. Callet, who had undertaken to correct the proofs of these tables, some very material errors had been committed in the first half of the tables, and M. Borda thought it necessary to cancel a great number of the pages; and in order to meet the expence thus entailed on him, he was obliged to dispose of an estate which he had lately acquired in his native place. He was also engaged, towards the close of his life, in the measurement of the force of magnetism, and in the calculation of astronomical refraction. His health had been threatened for several successive winters, and he died the 10th of March 1799.

In his manners he was animated and unaffected: he avoided those who sought his acquaintance merely from the vanity of being intimate with a man of talents, whatever pretensions to importance they

might derive from their casual relations to general society. He never married; and he was too much absorbed in the pursuit of science, to associate with a very extensive circle even of private friends. Though not a man of learning, he was not deficient in literary taste, and he was, in particular, a passionate admirer of Homer. He seems to have possessed a considerable share of that natural tact and sagacity, which was so remarkable in Newton, and which we also discover in the works of Daniel Bernoulli; enabling them, like a sort of instinct, to elude the insurmountable difficulties with which direct investigations are often encumbered; while Euler, on the contrary, as M. Lacroix most truly observes, seems to have taken pleasure in searching for matter which would give scope to his analytical ingenuity, although wholly foreign to the physical investigations which had first led him to the difficulties in question. It would have been fortunate for the progress of science, if some of the most celebrated of M. Borda's countrymen had profited by his example, in studying to attain that unostentatious simplicity which is the last result of the highest cultivation. (Lacroix in *Rapport des Travaux de la Société Philomathique*. Vol. IV. 8. Par. 1800.) (AL.)

BORING, generally speaking, is the Art of perforating a solid body. In the present article, we propose to give some account of the Boring of CANNON, of CYLINDERS, of MUSKETS, of PORTLAND STONE, of ROCKS, and of WOODEN PIPES.

1. Boring of CANNON is performed by placing the cannon on an axis which is turned by a very strong power, whilst a steel cutter, in form of a drill, is pressed against the metal, and excavates the cylindrical cavity which is required. Boring may be considered as a branch of the art of turning; which, in general, is the formation of cones, cylinders, and other figures that have an axis, by making a straight line or curve revolve round the axis on which the material is fixed, or by making the material revolve whilst the generating line remains at rest. In turning bodies of no great degree of hardness, and where it is required to take off only a small portion of the surface at once, a small power is sufficient to put the turning machine in motion; and the longer the edge of the cutter which is applied to the metal is, and the harder the metal, the greater force is required to turn the machine.

Cannon, at first, were frequently made of bars of malleable iron, placed longitudinally, and these bars covered with iron hoops, the whole welded or brazed together. Ordnance of this construction was not sufficiently strong to resist the explosion of the powder, and did not admit of the cylindrical cavity being formed with much accuracy. Its use was, therefore, gradually laid aside, and guns of cast metal were employed. And before the casting of cannon became general, guns of cast metal were reserved for the most important situations; thus the ships of the Admiral and Vice-Admiral alone had cast-metal cannon, the other ships of war being armed with wrought-iron guns only.

Copper, without mixture, has been employed to cast guns, as appears from two large cannon made in the time of Henry VIII. and bearing his name, in

Borda

Boring.

Cannon.

Cannon. the armoury of the Tower of London. But the only two materials now used for cannon are bronze, which is a mixture of copper and tin, and cast-iron. In modern times, the use of cast-iron cannon has become more general, as that metal has the advantage of not being softened by the heat of the inflammation of the powder; whereas brass guns, when fired many times in rapid succession, become heated so nearly to the melting temperature of the metal, that the muzzle of the gun droops.

The first cannon made of cast-metal were cast hollow, with a cavity as nearly cylindrical as could be executed by casting. The surface of this cavity was then smoothed on a boring machine by steel cutters set in a copper head, and disposed so as to describe a cylinder terminated by a half spheroid. These cutters (in French *alézoirs*, and the operation *alézer*) are represented in the French *Encyclopédie*—Planches—*Fonte*. This method of making guns has been long laid aside on account of the holes and inequalities in the cavity thus formed, and the difficulty of casting the cavity so as that its axis shall coincide with the axis of the piece. Cannon are now always cast solid, and the cylindrical cavity is formed by boring in this solid mass.

The power employed for boring cannon ought to be in proportion to the hardness of the metal of which they are composed, and to the size of the pieces. For the boring of guns of brass, as it is called, that is, a metal composed of ten parts of copper, one of tin, and two of brass, or of these metals in other proportions, a metal softer and more easily bored than cast-iron, horses are frequently employed as a moving power; but the strong moving powers of water or steam must be had recourse to for boring large guns of cast iron, which is the material used for making the largest guns now in use, and is also the hardest substance used in their manufacture. Indeed, some kinds of cast-iron are too hard to admit the action of the borer; and for the making of guns it is necessary to melt pig-iron of different qualities together, in order to have a metal that shall possess no more than the required degree of hardness.

The quality of pig-iron is known by the appearance of its surface, but more decisively by the appearance which its fracture presents. To obtain this fracture, a man takes one end of a pig in each hand, and lifting it as high above his head as he can, throws it with force, so that the middle of the pig shall fall across another pig placed on the ground; in this way the pig thrown down is broken. Soft or grey pig-iron, which is the most valuable, breaks with difficulty, and the surface of its fracture is of a grey colour, composed of pretty large crystalline grains. Hard or white pig-iron breaks easily; the surface of the fracture is white, and not sensibly granulated, the grains that compose it being small. The pig iron here spoken of is that smelted by the coak of pit-coal. Pig-iron smelted with charcoal of wood has a fracture of a different appearance, sometimes lamellar, like the fracture of a metallic bismuth. Formerly guns used to be cast from the blast-furnace; that is to say, immediately from the ironstone. This was attended with uncertainty in

Cannon. respect to the nature of the metal; for the nature of the metal given by the blast-furnace varies frequently and suddenly, from causes either unknown, or not under the command of the iron-master. For this reason guns are no longer cast from the blast-furnace, but pig-iron already formed is taken, of such qualities, and in such proportions, as to form a metal neither too soft nor too brittle and hard for guns. The different kinds of pig-iron thus selected are melted together in a furnace called, in iron manufactories, an *air-furnace*, and by some writers a *reverberatory furnace*, by the flame of pit-coal; the flame being impelled by a strong current of air produced by the rarefaction of the air in a chimney of thirty or forty feet in height, the column of the atmosphere of which the air in the chimney makes a part, being lighter than the unrarified columns of the atmosphere next it, its equilibrium with these columns is destroyed; the neighbouring columns therefore rush through the grate of the furnace, which is the only aperture by which they can attain the bottom of the rarified column, and they carry the flame of the coal against the pig-iron, which is thereby brought into fusion. From the iron thus fused only one large gun is cast at one time, the furnace not being capable of melting more metal than is requisite for that purpose.

The gun is cast with two appendages, which are to come off before it is finished and ready for use: The one is a square piece beyond the cascabel, for fixing the gun so as to revolve with the axis of the boring-mill; the other is the head.

The head in cast-iron cannon is a mass of cast-iron two or three feet long, somewhat bell-shaped. It is a prolongation of the mass of metal beyond the muzzle ring, and in the position in which the gun is cast, the head is the top of the whole mass, the square beyond the cascabel being the lowest part. After the metal has cooled, the upper surface of the head is cavernous, as is the case with the surface that is uppermost during the casting and cooling of any large body of cast iron: the sides of the cavities in the head are frequently formed of cast iron crystallized in a fern-leaf form. The intention of the head is to prevent these cavities, which are formed most abundantly at the upper surface of the cooling cast iron, from forming in the gun itself. But, notwithstanding the precaution of casting the gun with a large head, and of mixing proper kinds of cast iron in the air-furnace, it frequently happens that small cavities occur in the guns.

The gun with its head being cast and allowed to cool, is taken to the boring-mill, where the head is to be taken off, the cylindrical cavity or bore is to be formed, and the outside of the gun is to be turned. Formerly the boring of guns was done in an upright position; the gun being placed above the boring-bar was fixed in a frame sliding vertically in grooves; this frame was suspended on each side by a block and tackle, and the end of each of the two ropes was wound round a windlass. By turning these windlasses, the gun might be raised or lowered, and by this means might be allowed either to press with its whole weight on the boring-bit, or

Cannon. with any part of its whole weight. A figure of this apparatus may be seen in the French *Encyclopédie—Planches—Fonte*. Another vertical apparatus for boring cannon is represented in Rinman, *Bergwerks Lexicon*, Stockholm, 1789, Tab. IV.

Horizontal Boring. The practice which has long been followed in this country, is to place the gun horizontally in the boring-mill; and it is fixed on the axis of the mill by means of the square piece at the cascabel.

In a boring-mill constructed by Smeaton, one gun is placed on the horizontal axis of the water-wheel itself, and, consequently, revolves with the same velocity. On this same axis is a toothed wheel with 78 teeth, which works two wheels, one placed on each side of it, and each having 29 teeth; on the axis of each of these a gun is placed; their power is $\frac{1}{10}$ th of the power of the centre wheel. (See Smeaton's *Reports*, Vol. I.) On the axis where the power is least, smaller sized guns are bored; on the axis of the greatest power, the large guns are bored. A crane moveable on a vertical axis, with a sweep that extends over all the carriages, with a tackle hanging from its beam, and wrought by a windlass, serves to place the gun on the carriage where it is to be bored, or to remove it from one carriage to another if required; and afterwards, when the gun is bored and turned, the crane serves to remove the gun from the boring-mill.

The gun, when placed on the machine, has the square at the cascabel fixed in a square iron box (G, Plate XXXVI. fig. 5.), on the axis. This box has a screw passing through each of its sides, and by the operation of these screws, the square of the gun is adjusted, centered, and fixed; the chace of the gun is also fixed in a collar N, in which it is to revolve. (The collar in the figure is represented too near the muzzle ring.)

The axis on which each gun is fixed, may be set in gear or put in connection with the revolving axis of the machine, so as to move round with it, or taken out of gear, so as to remain at rest, although the other parts of the machine continue in movement. There are various methods of doing this; one is given by Smeaton in the work above cited. After the gun is fixed on the axis, and before beginning the operation of boring, the head, which has been described above, is cut off near the muzzle ring: for this purpose, the gun is set in gear so as to revolve on its axis with the moving power; and a bar of steel, in shape and size like the coulter of a plough, is applied at right angles to the axis of the gun; the narrow side of this bar is sharpened to a cutting edge, so that it has the form of one tooth of a very large saw; and this cutting edge is opposed to the direction of the revolving motion of the gun, and held strongly on to the gun by a screw pressing on the bar; the cutter takes off an angular portion at right angles to the axis, till the cylindrical part connecting the head with the gun is so much diminished, that the head is made to fall off by the blow of a hammer applied on it. In brass guns, cast with a core, the head was sawed off by hand with a blade of steel, whose edge was toothed as a saw, and the sides toothed as files. See the French *Encyclopédie—Planches—Fonte*.

VOL. II. PART II.

Cannon. A great degree of heat is generated by the violent friction of the steel-cutter on the cast-iron, during the operation of cutting off the heads of guns. The quantity of this heat has been estimated by Rumford in one of his *Essays on Heat*.

After the head is taken off, the workmen proceed to bore the gun. This is done by exposing the revolving gun to the action of a steel-cutter, fixed on the end of a bar, which bar is placed on a carriage, and impelled continually towards the gun. The operation of boring is done on the same axis on which the head was cut off, if the power be sufficient; if not, the gun is removed, by means of the crane, to an axis, where it is made to revolve by a stronger power.

The boring-bar is fixed on a carriage, sliding in iron grooves, which are truest when made triangular. The carriage, which, in the apparatus represented at fig. 5. consists merely of the bar on which the rack is, is pressed forward by a pinion P, whose gudgeons are on a fixed frame BB: this pinion works into a rack R. The axis of the pinion has mortise holes in it, through which one end of a lever L is passed; the other end of this lever is loaded with a weight W, which causes the pinion to propel the carriage and boring-bar towards the gun. In many boring-machines there are two pinions on the same axis, acting on two racks; in others, the carriage is propelled by two upright levers, on the end of one of which acts a weight, hanging from a rope, that passes over a pulley; the lower end of the upper lever acts on the upper end of the lower, whilst the lower extremity of the lower lever presses forward the carriage. This method, which is free from any inequalities that may arise from the teeth of the rack, is figured by Smeaton in his *Reports*, Vol. I. p. 396. Another method of propelling the carriage of the boring-bar, is by a screw acting on the end of the carriage. See Meyer in the *Transactions of the Acad. of Stockholm*, 1782, Tab. IX.

The boring-bar is a strong piece of wrought iron, of less diameter than the intended calibre of the piece, in order that the boring dust or shavings, detached by the cutter, may be got out. The boring-bar is increased in diameter near the end, for some inches; see fig. 6. B; in this part there is a superficial groove for receiving the sides of the steel-cutter or bit, which is to be firmly fixed in the bar. The bit T, fig. 6. is made from a rectangular piece of a steel bar, in which the two diagonally opposite upper angles are cut off obliquely, so as to form two cutting edges like an obtuse angled drill; the side of the rectangle, opposite to the point of the drill, is hollowed out in the form of a pigeon hole; this hollow fits into, and embraces, the solid part of the boring-bar, whilst the sides of the pigeon hole fit into the grooves of the bar. The point of this obtuse angled bit is pressed against the revolving metal of the gun, by the force which propels the boring-bar; and the edges coming in contact with the revolving metal, a conical cavity is produced; and by taking off successively a multitude of similar shells or shavings, the cylindrical bore, with a conical

z z

Cannon.

cal termination, is formed. The diameter of the pointed bit first used, must be less than the intended calibre of the piece, as the boring is to be repeated again at least once, in order to make the internal cylindrical surface as smooth as possible, by taking off any inequalities that have been left by the first cutter. In finishing the bore, a cross bit may be employed. It is a rectangular piece of steel, ground to a cutting edge at each end, and put through a hole in the boring-bar, in which it is fixed. The edges of this cutter, in revolving, describe a cylindrical surface. After the cylindrical surface of the bore is made sufficiently true, and of the required calibre, a bit without a point, and rounded off to the desired curve, is used to form the bottom of the chamber.

Some recommend, that the boring bit for cast-iron should have its cutting edges brought to an acute angle, by being filed hollow; but in this case the two edges cannot be brought into one point; but the obtuse angled edge formed by the thickness of the metal of the bit, joins the two cutting edges crossways, and forces itself forwards by being near the centre, requiring, however, a considerable pressure. These hollow edged bits are not so well adapted to continuance of grinding, as the plain ones, but they make amends by their much less frequently wanting sharpening. It does not appear, however, that these hollow edged bits have been found advantageous in gun boring.

The howitzer appears to have had its origin in Germany. This piece of ordnance, the mortar, and the carronade, in all of which the diameter of the chamber for the powder, is smaller than the diameter of the rest of the bore, are first bored all through, nearly to the intended calibre of the chamber, and then that part of the bore that requires it is enlarged.

The cutters, in gun boring, become magnetic, in consequence of being continually rubbed in the same direction, so that the boring dust is seen adhering and hanging from their edges, when they are withdrawn from the gun.

It is required, that the bore shall be a cylindrical cavity, whose axis coincides with the axis of the gun; for this purpose, care must be taken to place the axis of the boring-bar, and that of the gun, both in one horizontal line, and it is requisite that these two lines continue in this position during the whole operation of boring. The centering of the boring-bar for this purpose, requires to be done by an experienced workman, and an accurately constructed boring-machine is necessary for the continuance of the right position.

Whilst on the axis of the mill, the gun has a smooth outer surface given it by turning tools, which are applied in the way usual in turning metals; a wooden gauge, or cut-out profile, of the gun, with its intended mouldings, being applied to know when the turning has been continued to a proper depth. When this is done, the gun is taken out of the boring-mill,—the square, at the cascabel, is cut off by the chisel,—and the trunions, and other parts which are not susceptible of being turned, are dressed by

Cannon.

the chisel. The cyphers and arms which had been cast on the gun, are finished by the chisel.

A cannon is said to be the *ultima ratio regum*,—the last argument that governments have recourse to; and even this severe kind of argument has sometimes been embellished. Amongst ornamented cannon, the brass three-pounder in the Tower, brought from Malta, is a masterpiece: it is covered with carving in a good taste, by a sculptor of Rome.

The touch-hole is drilled by stock and bit, or by drill and bow; the drill being propelled by a lever placed on a carriage, moveable on wheels. A figure of this apparatus is given in the *Encyclopédie—Planches—Fonte*. Another apparatus for this purpose is figured in Rinman, *Bergwerks Lexicon*, Tab. XIV. fig. 9, 10. See also Monge, *Description de l'Art de Fabriquer les Canons*, in 4to, Paris, 1794. This work was published by order of the revolutionary government, and distributed to the Ironmasters and Founders, in different parts of France, for their instruction. It contains, amongst others, figures and descriptions of two kinds of vertical boring machines,—of three kinds of horizontal boring machines,—of a machine for turning the trunions,—of two different machines for boring the touch-hole,—of a machine for putting copper bushes in brass guns,—and of various instruments for examining and proving guns.

Before the gun is sent off, it is examined and proved in various ways. And first to ascertain whether the bore is free from holes, an instrument is employed, consisting of several elastic steel prongs disposed in a circle, and with their sharp points turned outwards; this being fixed on a hole, is introduced into the bore of the gun, and drawn to and fro; the points of the prongs press against the sides of the bore, and the presence of a hole is known by one of the prongs getting into the hole, and preventing the instrument from being drawn out directly, unless by the use of a ring that is pushed over the prongs to unbend them.

There is another instrument, composed of a board twice as long as the bore of the piece; along the middle is a groove proceeding in a straight line. In this groove a button is moveable, and on the button as a centre are fixed two radii or arms; the two ends of these arms within the gun describe a line on the inside of the bore when the button is pushed inwards, whilst the extremities of the arms on the outside describe two lines similar on the part of the board that is situate without the bore: in this way the outline of a longitudinal section of the bore is described, and its sinuosities or deviation from the axis are rendered sensible. This instrument is seldom used: it requires to be made by a workman skilled in the construction of mathematical instruments, or in watchmaking.

A lighted wax-candle is introduced into the gun for the purpose of seeing any defects there may be in the box, or the light of the sun is reflected into the box by a mirror. The strength of the gun is proved by firing it with a large charge of powder; and by forcing water into the bore by a powerful forcing pump, the touch-hole being stopped, and the

Cylinders. mouth of the piece, so that water forced in by the mouth cannot return that way.

2. BORING OF CYLINDERS for steam-engines, and for blowing machines, and the boring of the working barrels of large pumps, and other hollow cylinders in which pistons are to work, is performed by making the steel-cutters describe a cylindrical surface on the inside of the cylinder, whilst the cylinder remains fixed. The first steam-engine cylinders in this country were of brass, or of a mixture of copper and tin; this was the case with the cylinder of the steam-engine, erected in the early part of the eighteenth century, for lifting water from the colliery of Elphinston in Stirlingshire. But, since that time, the construction of steam-engines, and the manufactory of cast-iron, have been greatly improved; the uses of both have been much extended; and cast-iron has now for a long time been the only material employed in making cylinders for steam-engines, and other large cylinders in which pistons are to move.

In the boring of cylinders, the steel-cutters are fixed in a cutter-head, which revolves with the boring bar at the same time that it is impelled along the interior surface of the cylinder by a rack, with a pinion moved by a lever and weight as already described. The axis or boring-bar, employed for cylinders, is a hollow tube of cast-iron, and has a groove passing through it: the length of this groove is proportioned to the length of the cylinder to be bored. The cutter-head consists of two cast-iron rings, the first of which is accurately fitted on the boring-bar, which is turned truly cylindrical, so that this ring may slide along the boring-bar; the second ring is fixed round the first by wedges; its diameter is proportioned to the diameter of the cylinder to be bored; on its circumference are eight notches to receive the steel-cutters, which are fixed in by wedges. The first ring is fixed on the boring-bar, so as to make the whole cutter-head move round with the boring-bar, by means of two small iron bars, which go through notches in the first ring, and pass through the groove of the boring-bar. These small bars have each a round hole in the part which passes through the geometrical axis of the boring-bar; through these round holes there passes a bolt, which forms the end of the rack; a key is put through the end of the bolt, which prevents the rack from being drawn back by the lever and weight; and by this means, the rack impelled by the lever and weight pushes forward the cutter-head, which is at the same time revolving with the boring-bar: the connection of the rack and cutter-head being round, and in the axis of motion, the rack is thereby free from the circular motion of the cutter-head. This mode of constructing the boring-bar was invented in the works of Mr Wilkinson, at the time when accurately bored cylinders came to be required in consequence of Mr Watt's improvements in the steam-engine. In the machines about to be mentioned, the cutters are made to advance by a train of wheels deriving their motion from the power that turns the boring-bar.

Billingsley's Machine. An apparatus of great merit was contrived and described in 1802 by Mr Billingsley, Engineer of the

Bowling Iron-works, near Bradford. (See *Repertory of Arts*, second series, Vol. II. p. 322.) In this method, the cylinder is placed with its axis perpendicular to the horizon. The object of which is, first, that the boring-dust may fall out, and not remain on one side of the cylinder, wearing the cutters; so that in this way the cylinder may be bored through without changing the cutters, by which means a more regular bore is obtained. Secondly, That the cylinder may not deviate from its cylindrical form by its own weight, a deviation which is found to take place in large and slender cylinders when laid on their side; the vertical diameter being then less than the horizontal diameter. A similar loss of shape may happen to cylinders that are improperly wedged and strapped down for the purpose of being bored. In this method, the cylinder is fixed with screws by the flanges, where it is most capable of resistance, and the screws are disposed so as to press the cylinder equally all round. Thirdly, That the operation may be sooner completed, which is effected in consequence of less time being employed to fix the cylinders in this method. In the usual mode of propelling the cutters described above, the attendance of a man is necessary to change the position of the bar on the axis of the pinion, and to raise the weight. This attendance is dispensed with in the machine under consideration, the mechanism for propelling the cutters being as follows. A leather strap passing over the boring-bar, communicates the revolving motion of the boring-bar to a wheel, which communicates a slow motion by a train of wheels and pinions to an axis, bearing two pinions which work into two racks; these racks push the boring-head and cutters slowly forward on the boring-bar, at the same time that the boring-head is revolving with the boring-bar. The velocity with which it is required that the cutters shall advance, varies as the diameter of the cylinder varies, the moving power remaining the same. And by altering the train of wheel-work, the cutters may be made to advance with any velocity required.

Figs. 1, 2, 3, and 4, Plate XXXVI., are different views of the machine for boring cylinders, invented by Mr Murray of Leeds. Fig. 1. is an elevation, and fig. 2. a plan of the machine. W fig. 1. and 2. is the spur wheel, deriving its motion from water or steam, and communicating a revolving motion to the boring-bar. The toothed wheel A fig. 1. moves round with the boring-bar B on which it is fixed; it gives motion through the wheels D and E, and to the screw S, whose threads act on the two racks, which racks are fixed to the cutter-head H, and revolve with it. The velocity with which the cutter-head is impelled along the cylinder, depends upon the number of threads of the screw in a given length, and on the proportions of the wheels A, C, D, and E to each other. By varying the velocity of the screw, the cutter-head may be made to move in either direction, up or down the cylinder. F is a pinion, whose axis ends in a square, which may be wrought by a key, so as to bring the cutter-head out of the cylinder, or push it home by the hand when that is required.

The cylinder is fixed in its bed by screws passing through two iron rings, as represented at fig. 4.; in

Cylinders
Muskets.

this way the cylinder is equally pressed in the different parts of its circumference.

Fig. 3. is a transverse elevation of the collar in which the end of the bar at A, fig. 1. turns; X is the gudgeon in which the spindle X, fig. 1. turns. In fig. 3. are also seen the two apertures through which the two racks pass.

By this machine also, the flanges are turned truly plane, so that the lid of the cylinder may fit on exactly.

Murdoch's
Patent.

The patent granted in 1799 to Mr Murdoch, Engineer, Redruth, for new methods of constructing steam-engines (See *Repertory of Arts*, Vol. XIII.), contains some articles relative to boring. He employs an endless screw, turned by the moving power; this screw works into a toothed wheel, whose axis carries the cutter-head; and this method, he says, produces a more smooth and steady motion than the usual mode of fixing the boring-bar immediately on the axis turned by the moving power.

Another article in Mr Murdoch's patent that relates to boring, is his method of forming the cylinder and steam case. He casts them of one solid piece, and then bores a cylindrical interstice, by means of a boring tool, made of a hollow cylinder of iron, with steel-cutters fixed to its edge, and acting like a trepan.

The chambers of brass pumps, whose diameter does not exceed a few inches, are fixed within iron rings, by means of screws, in the manner described above when speaking of Mr Murray's apparatus. The rings are made accurately cylindrical by turning, as is also the boring-bar. The boring-bar has four cross arms on its outer extremity, to one of which a handle is fixed, whereby a workman makes the boring-bar revolve. The cutter-head is made to advance along the boring-bar by a screw.

Muskets.

3. BORING THE BARRELS OF MUSKETS AND OTHER SMALL ARMS. Rectangular pieces of iron are forged of a proper length and breadth; these are heated in the fire, and the two long edges, which had been previously thinned off, are welded together on a mandril. The barrel thus formed, is fixed by a screw on a carriage that moves in iron grooves; this carriage is propelled towards the boring-bar by a rope which passes over pulleys, and has a weight hanging from its end. The boring-bar is turned by the power of the same mill that turns the grinding-stones for polishing the outside of the barrels. (See *Encyclopédie—Planches—Arquebusier*; and Rozier, *Introduction aux Observations sur la Physique*, Tom. I. p. 157.) Water is thrown on the barrels whilst boring from a trough placed underneath. After the barrel is bored, the interior surface of the bore is polished by the action of the boring-bar. The barrel is tried during the operation, by an iron gauge of an inch and a half in length, and of a diameter equal to the intended diameter of the musket. When the barrel is bored, it is held to the light and looked through, and if it contains any flaw, the place of that flaw is marked on the outside with chalk, and the barrel is put on the mandril again, and the defective place heated and hammered; the workman also examines with a gauge, whether the barrel is crooked. When the bore has no flaws, the

barrel then undergoes the operation of the grinding-mill, to the effect of polishing its exterior surface.

Muskets
Portland
Stone.

Rifled-barrels are put on a bench twelve feet long. The boring-bar is guided by a matrix or female-screw, whose spiral curve is similar to the spiral of the rifles intended to be made; the boring-bar being fixed to a male-screw, which passes through the female-screw, and fits it exactly. The female-screw is fixed to the bench, and has four threads and as many furrows; these threads, in general, return to the point of the circumference from which they set out, or make a revolution in the length of two feet. The male-screw, which fits into the female-screw, has at one end an iron bar attached to it, by which it is put in motion; at the other extremity is fixed the boring-bar, which passes through the barrel to be rifled; the boring-bar has a cutter fixed in it, which forms a spiral furrow in the barrel when the screw is turned by the handle. The number of spiral threads in rifle-barrels is from three to twelve. Sometimes the threads and furrows of the rifle-barrel are required to be in straight lines; in this case a straight lined matrix is used. In order that the threads may be placed at an equal number of degrees of the circumference from each other, the bench is furnished with a brass plate, divided in the same way as the plate of the machine for cutting the teeth of clock-wheels.

4. BORING OF PORTLAND STONE, so as to form ^{Portland} pipes. That kind of calcareous stone, called by ^{Stone.} Geologists oolite, which is quarried for building at Portland, Bath, in the neighbourhood of the city of Paris and other places, admits of being cut with an iron blade, with sand and water, acting as a saw. The more compact limestones and marbles are also cut in this way, but not so easily. The other kinds of stone that can be squared for building, namely sandstone and granite, do not yield to the saw, but are formed into the desired shape by the chisel and hammer. A modification of this mode of working Portland Stone, consists in forming it into pipes. The method of Sir George Wright, proposed in 1805, is as follows: A hole is drilled through the block of stone, in which a long iron bolt is inserted for the saw to work round as a centre; this bolt forms the axis of the cylinder which is to be taken out, and projects considerably beyond the block at both ends. Another hole is drilled in the intended circumference; into this the blade of the saw is introduced. The frame of the saw is so disposed, that when it is wrought to and fro, the blade is guided by means of the centre bolt so as to describe the intended cylindrical circumference. In this way a solid cylindrical core of stone is detached, and a cylindrical cavity or pipe left in the block. Or the saw may be made to describe a circle without drilling a hole in the centre, by drilling a hole in the circumference, and fixing on the surface of the stone two metallic concentric rings, so that the hole shall be included in the interstice between the rings. The saw is then introduced into the hole, and being worked, it cuts in the circular path formed by the interstice of the rings. See *Repertory of Arts*, second series, Vol. VIII.

Mr Murdoch's method, for which he obtained a

Portland
Stone
Rocks.

patent in 1810, is preferable in practice to the above mentioned method. He employs a cylindrical saw to form the pipe. A plug of wood is inserted in the centre of the intended pipe; this plug receives the lower end of a vertical spindle, longer than the intended pipe; this spindle is square, and has sockets sliding on it. On the upper part of the spindle is a pulley or toothed-wheel, by which the spindle is made to revolve. Near the lower end of the spindle is a wheel, having a circumference like a hoop, three inches broad. The diameter of this wheel is somewhat less than that of the pipe to be bored. It regulates the motion, and fits in the inside of a tube of metal attached to the spindle. The diameter of the tube is nearly equal to that of the intended pipe; its length is greater by two feet. On the lower edge of the tube is a rim of metal, so much thicker than the tube, that the groove cut in the stone by the rim, may admit the tube to move freely in it. This rim has an edge like that of a stone-cutter's saw, and performs here the office of a saw. The tube is caused to make a reciprocating circular motion round the spindle. There is a cistern placed above the tube, for the purpose of conveying a mixture of sand and water into the cylindrical groove formed in the stone, whilst the machine is working.

Stone pipes, made in the above described way, have been tried for conveying water in London. They were joined by means of Parker's cement, which consists of clay ironstone, burnt, and ground to a fine powder. This was the best material that could be got for forming the joints; but these joints cracked, and allowed the water to escape in consequence of the motion of the carriages on the streets under which the pipes were laid; and the adventurers found that they "had hewed out unto themselves broken cisterns, that could hold no water."

Rocks.

5. BORING OF ROCKS, for the purpose of splitting them by means of gunpowder. We have already treated this subject under **BLASTING**, and shall only add here the mode of boring for this purpose practised in the mines of Germany.

A boring bar of steel is applied to the stone by its lower end, whilst its upper extremity is struck with a hammer of two pounds in weight. The form of the lower end of the boring-bar is various; some were formed like a swallow's tail, ending in two points; this form is no longer in use. Another kind has the end formed by the intersection of two wedge-shaped edges, with a point at each corner, and one in the middle. A third kind has the end composed of four pyramidal points, with cavities between them. A fourth kind, and which is that most frequently used, has the end in form of a wedge. See Rinman, *Bergwerks Lexicon*. Stockholm, 1789, Tab. II. Three sizes of boring bars are employed to make one hole; the first is the shortest and thickest, the second is longer and less in diameter, the third is the longest, and the least in diameter. When a hole is to be made, a small opening is first formed with a pick in the place where the boring-iron is to be applied; and all pieces of the rock are removed that might impede the action of the powder. Then the workman uses the first boring-iron, which he drives with blows of the hammer till this boring-iron

can reach no farther; he then employs the second and third boring-bars in like manner; after each stroke of the hammer, the boring-bar is turned round a portion of the circumference. The stone, pulverized by the action of the boring-bar, as it hinders the progress of the operation, must be removed from time to time by means of an iron rod, terminated at right angles by a small round plate. From the different diameter of the boring-bars, it follows that the end of the hole is of a smaller diameter than the beginning. The depth to which the hole is bored is proportioned to the nature of the rock. It varies from 10 to 15 and 20 inches. When the rock is solid a great way round, a deep hole is not used, because the resistance at a considerable depth, in such a situation, is too great; so that the explosion does not split the rock round the powder chamber, but acts upwards against the ramming, where it meets with less resistance. But if the rock be laid bare on one side, a deep hole is advantageous. Water is poured into the hole during the operation, to facilitate the action of the boring-iron. When the hole is perpendicularly downwards, it is kept full of water; when the hole is driven from below upwards, no water can be used. The water must be taken out, and the hole dried, before the cartridge is introduced. The most frequent case is, that one man performs the work, holding the boring-iron in his left hand, and striking on it with the two pound hammer in his right. Sometimes two men are set to do the work, one holding the boring-iron, whilst the second strikes it with a hammer of 4 or 5 pounds; this is done where it is required to make the hole 30 or 36 inches deep. When a still deeper hole is wanted, two men strike alternately with heavier hammers.

Rocks
Wooden
Pipes.

6. BORING OF WOODEN PIPES, is done by means of a long auger, beginning with one of small diameter, and proceeding to employ successively spoon-formed augers of larger diameter. Notwithstanding the frequent employment of cast-iron pipes, some wooden pipes are still used for conveying water in London; they are of elm, which is the kind of tree most frequent in the neighbouring country. A pipe is bored out of one trunk of elm, and the bark is left on. When a tree is to be bored, it is fixed on a carriage, with a rack on the under part. This rack fits into a pinion, whose axis passes through gudgeons on a fixed frame. On the axis of the pinion is a ratchet wheel, moved by two catches, which derive their motion from the wind or water power that turns the auger; and the pinion is moved in a direction that brings the tree towards the auger. See a figure in the *Encyclopædia Britannica*, Plate CCCXIX; and in Belidor, *Architecture Hydraulique*, I. 1, 341. This apparatus is the same as the one employed in saw-mills. In the boring of pipes for the water-works in London, the tree is made to advance by ropes, which pass over a windlass wrought by men, whilst the auger is turned by a horse-mill. Wooden pipes are frequently bored by an auger having at its outer end a wooden drift or handle, which is put in motion by the workman. The trees are placed on tressels, and there are also tressels of a convenient height that support the auger; there is also a lathe

Boring
Bora.

to turn one end of the tree conical, so as to fit into a conical cavity in the end of the adjoining tree, and thus form a joint water-tight. The end of the tree, which receives the adjoining pipe within it, has a surface at right angles to the axis of the pipe. Into this surface is driven an iron hoop, whose diameter is some inches greater than the diameter of the aperture of the pipe. This precaution prevents the tree from splitting when the conical end of the next tree is driven home. When the tree is crooked, a bore is driven in from each end, and the two bores meet, forming an angle. An auger, whose stalk is formed spirally for some way up, is figured in Bailey's *Machines of the Society of Arts*. The object of this is that the chips may be delivered without taking the auger out of the hole.

There is a patent granted in 1796 to Mr Howell, Coalmaster, of Oswestry, for boring wooden pipes by a hollow cylinder, made of thin plates of iron, about an inch less in diameter than the hole to be bored. To one end of this cylinder is fixed a flange about a quarter of an inch in breadth, and one part of this flange is to be divided, so that, being of steel, a cutter is formed thereby. The object of this method is to bore out a solid cylinder of wood, capable of being converted into a smaller pipe, or of being applied to some other use in carpentry. (*Repertory of Arts*, Vol. IX.) This kind of borer is like the trepan, which is a hollow cylinder of steel, saw-toothed on the edge, and, when made to revolve rapidly on its axis, in the hand of the surgeon, it saws or bores out circular pieces of the flat bones of the head. (v.)

BORN (IGNATIUS) BARON VON, Counsellor in the Aulic Chamber of the Mint and Mines at Vienna; of considerable eminence in the scientific world as a Mineralogist and Metallurgist, and a promoter of science; was born of a family that had the rank of nobility, at Karlsburgh in Transylvania, in 1742; and died in 1791. He was educated in a College of the Jesuits at Vienna, and afterwards entered into that order, but continued a member only during sixteen months. He then went through a course of study in law at Prague, and afterwards travelled into Germany, Holland, and France. On his return to Prague, he engaged in the study of Mineralogy.

The mines in the dominions of the house of Austria are very important, and give livelihood to a numerous population, more particularly in Hungary, Transylvania, and the Bannat, and in Styria and Carinthia. Idria produces mercury; Bohemia, tin and cobalt; and the other metals are got in sufficient abundance, not only to supply the internal trade of the nation, but also for export, either in the form of raw metal, or manufactured into various instruments. A revenue accrues to the public Treasury from the mines in various ways. Some, as those of Schemnitz, Cremnitz, and Idria, are wrought on account of government. A tenth part of the produce of all mines wrought by private adventurers goes to Government as a royalty. Government has a right of pre-emption of all metals, and an exclusive right of buying all gold and silver, the produce of the country, at a stated price. The annual quantity of gold and silver got from the mines of Hungary and Transylvania, and coined into money at the Mint,

during the reign of Maria Theresa, amounted in value to about L. 300,000 Sterling. The mines in other parts of the dominions produced likewise a considerable quantity. Maria Theresa, seeing their importance, did much for the regulation of the mines; and, with a view of diffusing the knowledge of Mineralogy amongst the nobles, many of whom were proprietors of mines, she had lectures on that science delivered in the Universities. The administration of the revenue arising to Government from this source, is conducted by a Board composed of Managers, Overseers, Assayers, and other Officers, who are brought up in the knowledge of Metallurgy and Mineralogy, and reside at the mines. The operations of these functionaries are under the control of the Aulic Chamber of the Mint and Mines at Vienna, which keeps a set of books where all the transactions relative to the mines, and their situation and state, are digested and registered. An administration thus constituted offers a field of some preferment. Von Born chose to devote himself to this line of life, and was received into the department of the Mines and Mint at Prague in 1770.

About this time he met with an accident which nearly proved fatal. In the course of a mineralogical journey through Transylvania, he came to Felső-Banya, where, the gang is rendered brittle and detached from the rock, by exposing it to the flames of wood heaped up in the mine and set on fire. Having gone into the mine soon after the combustion had ceased, and whilst the air was hot, and charged with arsenical vapour, and returning through a shaft which was occupied by a current of this vapour, he was deprived of sensation for fifteen hours, and, after recovery, continued long to suffer from a cough and general pain. Some time after this accident, he was affected with violent colics, which a large dose of opium removed, but left him with a numbness of the lower extremities, and lame in the right leg. In the latter part of his life he was deprived of the use of his legs. All these calamities, which, however distressing, did not repress the activity of his mind, were considered as the consequences of the arsenical fumes he had inhaled at Felső-Banya.

One of the chief objects of his exertion was to introduce amalgamation in Hungary, in place of smelting and cupellation heretofore used in that country, for extracting silver from the ores. Pliny and Vitruvius speak of the use of mercury in collecting small disseminated particles of gold. On the arrival of the Spaniards in America, the Peruvians extracted the silver from the ore by smelting-furnaces, exposed to the wind on the tops of hills. The quicksilver mines of Guancabellica in Peru were discovered in 1563, and three years thereafter the Spaniards began to employ amalgamation. Alonzo Barba, an Andalusian, farther improved the process by the addition of heat. Amalgamation had been practised in Europe for collecting silver and gold when they existed in visible metallic particles, but not in the case of ores where the gold and silver are invisible, even with the aid of a microscope. Soon after its application to ores in America, an attempt was made by a Spaniard to introduce this operation

Fig. 1.

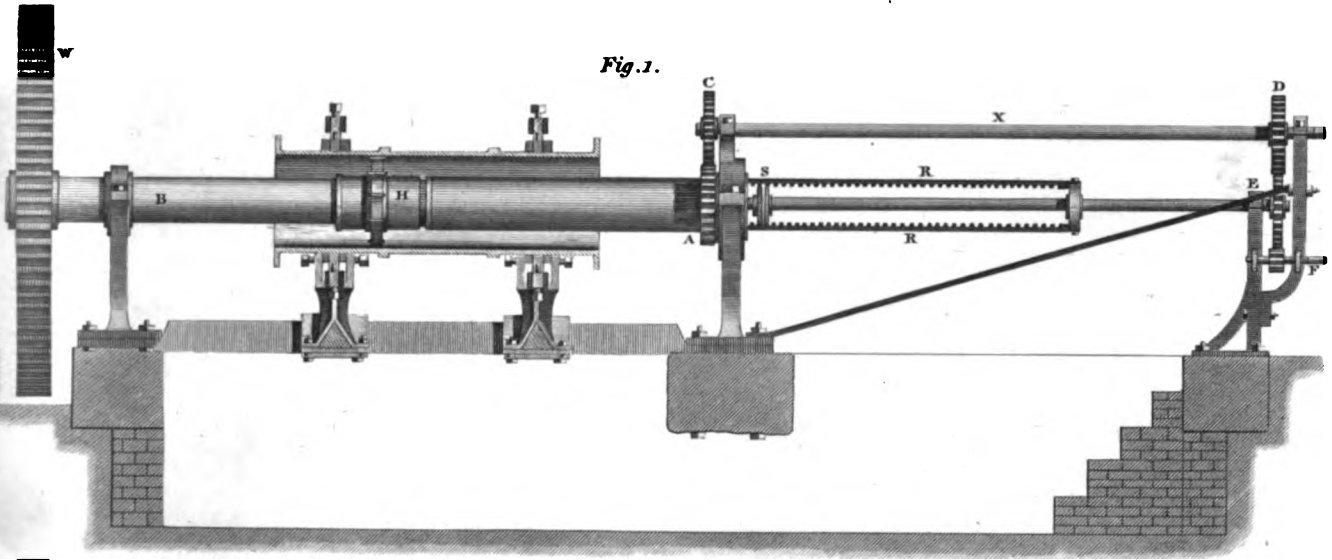

Fig. 2.

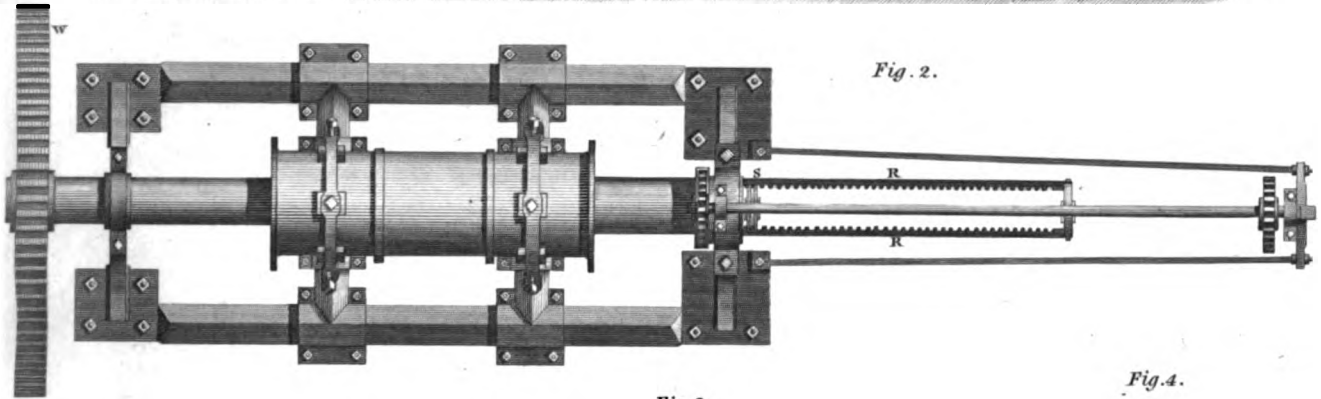

Fig. 3.

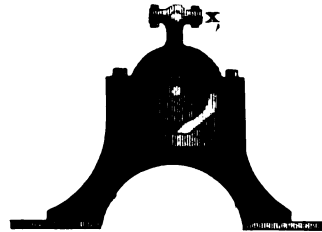

Fig. 4.

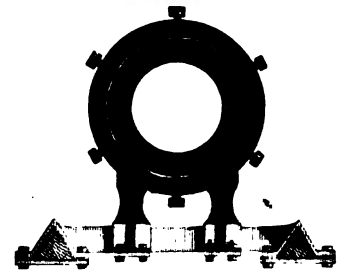
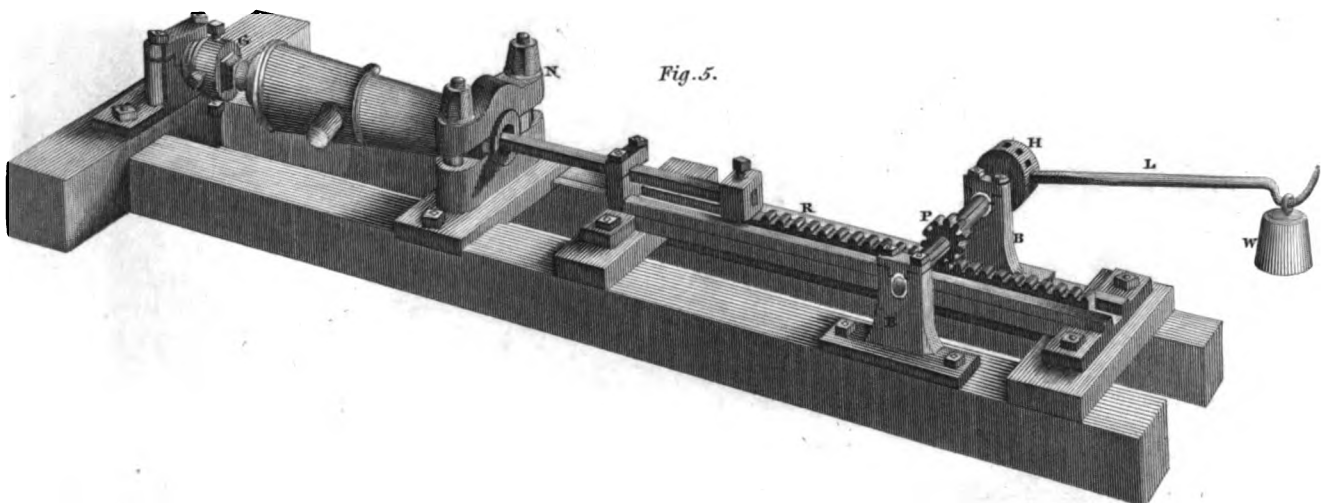

Fig. 6.



Fig. 5.



Born. for extracting silver from the ores in Bohemia, but without success. Gellert, Walerius, and Cramer, had written against the use of Amalgamation when applied to ores. But Von Born, seeing its advantages, particularly in the saving of fire-wood, which had become scarce in many parts of Hungary, set about examining the accounts given by authors of the different processes used in Mexico and Peru; repeated these processes experimentally, first in the small way, leaving out the ingredients that a knowledge of the chemical action of bodies showed to be unnecessary; afterwards he had the process carried on in the great way for several months near Schemnitz, under the inspection of Ruprecht. At this time he published his book *On Amalgamation*. It contains a history of Amalgamation, and extracts from different authors describing the South American methods. This occupies nearly one half of the volume. He then gives the chemical theory of operation in its different steps, describes the method he had adopted at Schemnitz, and gives figures of the machinery employed.

Von Born met with much opposition in his attempts to introduce Amalgamation. He says that some book-learned Chemists, who never had handled a retort, and some Mine-Overseers, when he first set about his experiments, declared that it was impossible to obtain silver by that method. After he had succeeded in getting silver from the ore publicly at Vienna, his detractors came forward with doubts and long calculations, showing that the process was inferior to that already in use. At last his process was tried successfully in the great way by orders of Joseph II. at Schemnitz; and then the calculators and doubters shrugged up their shoulders, saying, "It is only the old Spanish process of Amalgamation."

He obtained from the Emperor an order that his method should be employed in some of the mines belonging to Government, and that he should receive a third part of the savings arising from the improvement during the first ten years, and four *per cent.* of this third part of the savings for the next twenty years.

He was a Satirist, without possessing the qualities of style that are necessary to attain a high rank in that class of writers. The *Staats Peruche*, a tale, published without his knowledge in 1772, and an attack on Father Hell, the Jesuit, and King's Astronomer at Vienna, are two of his satirical works. The satirical description of the *Monastic Orders*, written in form of an academic inaugural dissertation, entitled *Monachologia*, is generally ascribed to Von Born. In this piece the Monks are described in the technical language of natural history. Von Born, however, was not deeply versed in the phraseology of Linnæus; and it is the opinion of some good judges of the subject, that the language at least was furnished by Hermann, Professor of Medicine in the University of Strasburg, and author of the very ingenious work on the mutual affinities of animated beings, entitled, *Tabula Affinitatum Animalium Commentario illustrata*. But although the technical language may not be Von Born's, the sentiments are such as he was known to profess; for the to-

Boin. pic was so great a favourite with him, that he found room for invectives against the monks even in his book *On Amalgamation*. The Monks in the Austrian dominions were not then in a situation to obtain redress against this lampoon; for it was published in 1783, when Joseph II. had suppressed many of the Monasteries in different parts of his dominions, and transferred their property into his treasury, allowing but a scanty sum for the subsistence of the members of these communities.

Von Born was well acquainted with Latin, and the principal modern languages of Europe. He also possessed information in many branches of science not immediately connected with Metallurgy and Mineralogy, which were his professed pursuits. He had a good taste in the graphic arts, and his printed works are ornamented in a neat manner with vignettes illustrative of the subject.

His inclination led him to engage in politics; and, in particular, he took an active part in the political changes in Hungary. After the death of Joseph, the Diet of the States of Hungary passed a great many acts, rescinding the innovations of that scheming Ruler, which tended to force upon them German Governors and laws, and even the German language. This Diet conferred the rights of denizen on several persons of distinction who had been favourable to the cause of the Hungarians, and, amongst others, on Von Born. At the time of his death, he was employed in writing a historical work in Latin, entitled, *Fasti Leopoldini*, probably relating to the prudent conduct of Leopold II., the successor of Joseph, towards the Hungarians.

He was of a middle size, slender made, and dark complexion; his eye was penetrating and his countenance agreeable. His constitution was delicate even before his accident. He was a pleasant companion and fond of society. He lived in splendour, and his house at Vienna was resorted to by scientific men of all nations. It is likely, that his profits from the process of amalgamation were not considerable; at least, they were not sufficient to put his fortune to rights, as his affairs, at his death, were in a state of insolvency. His family consisted of a wife and two daughters, who survived him. See Townson's *Travels in Hungary*, and Pezzil, *Osterreich Biographien*, 1792.

The following is a list of his published writings, and of the works of others which he edited:

Lythophylacium Borneanum, 1775, 8vo. This is a Catalogue of his collection of minerals, which collection he afterwards sold to Mr Greville, and it forms a part of the magnificent Greville Collection of Minerals, purchased from the heirs of that gentleman by Parliament, and deposited in the British Museum. This Catalogue is arranged according to the system of Cronstedt, with the nomenclature of Linnæus.

Index rerum naturalium Musæi Cæsarei Vindobonensis. Pars. I. *Testacea*. Vindob. 1778, fol. maj. This splendid volume, which contains the description and figures of the shells in the Museum at Vienna, was composed by order of the Empress Maria Theresa. The shells are arranged according to the

Born.

method of Linnæus. Von Born's knowledge in this department of Natural History was not profound, so that, he needed some assistance in composing the work. The shells only are described; of the animals to which they belong little is said. Joseph II. coming to the throne, and being fully occupied with a multitude of innovations and vast schemes for the aggrandizement of the House of Austria, the project of continuing the work, so as to form a description of the whole Museum, was laid aside.

On the Amalgamation of Ores containing Gold and Silver, in the German language, published in 4to, in 1786. Of this work something has been already said above. There is a translation of the work into English, by Raspe, a Hanoverian, once Professor at Hesse Cassel; and who afterwards resided in Britain, where he was sometimes employed as a viewer of mines.

Catalogue methodique et raisonné de la Collection des Fossiles de Mademoiselle Eleonore de Raab, à Vienne, 8vo, 1790. This catalogue is drawn up so as to form a system of mineralogy, each species of mineral being carefully described, and arranged systematically. It was well esteemed, and cited by mineralogical writers in its time, but has been superseded, like other treatises, by more recent works, on account of the great additions that have been continually making to the science.

He edited the Jesuit Poda's description of the machines used in the mines of Schemnitz.

Ferber's Letters from Italy; were written to and edited by Von Born. Ferber and he were in habits of great intimacy; and, Ferber in return, published the letters that Von Born addressed to him, during his excursion in Transylvania, &c. in 1770; entitled *Briefe über mineralogische gegenstände auf seiner reise durch das Temeswarer Bannat, Siebenburgen, Ober und Nieder Hungarn*. Frankf. 1774. To this work is prefixed a well engraved portrait of Von Born. There is an English version by Raspe, and a French one, with notes, by Monnet.

He lent his assistance to the first three volumes of a work published in German, entitled *Portraits of Learned Men and Artists, natives of Bohemia and Moravia*.

There are some papers of his in the *Abhandlungen der Böhmischer gesellschaft den Wissenschaften*.

The Transactions of a Private Society at Prague, in Bohemia, for the improvement of Mathematics, Natural History, and the Civil History of the country, contains several papers written by him. He was the founder of this society.

He published an annual periodical work in German, entitled *The Philosophical Transactions of the Masons' Lodge of Concord at Vienna*. This masons' lodge, of which Von Born was the founder and patron, employed a part of its meetings in scientific pursuits. This, as well as other societies of a similar nature, was tolerated by Joseph II. for some time; but he afterwards imposed restraints that caused its dissolution. Von Born was also a zealous member of the Society of Illuminati; and when the Elector Palatine of Bavaria suppressed the masonic societies in his dominions, Von Born being a member of the Academy

of Sciences of Munich, was required to declare, within eight days, whether he would withdraw from the masonic societies. He returned an answer, in which he praised the principles of the free-masons, and resigned his place in the Academy, by sending back his diploma.

He wrote some articles in the German work published by Trebra, mine-director at Zellerfeld in the Hartz, entitled, a *System of Instruction in the Art of Working Mines*, 4to. Also, *Observations in support of the Metallization of the Alkalis*, in Crell's *Annals*; 1790, 1791. Ruprecht and Tondi thought at that time that they had reduced the alkalis and barytes to a metallic state, by the strong heat of a furnace urged by bellows; but it was afterwards found that the metallic substance thus obtained was phosphate of iron, proceeding from their crucibles and fluxes. Sir Humphry Davy was the first who obtained any of the alkaline class of bodies in a metallic state; and this he accomplished by the intense heat excited by a galvanic battery, many years after the time heré spoken of.

Relatio de Aurilegio Daciæ Transalpinæ, 1789, in the *Nova Acta Academiæ Naturæ Curiosorum*, Tom. VIII. p. 97. This is an account of the method employed in Transylvania in collecting gold from the sand of the rivers. The auriferous sand generally contains iron, attractable by the magnet. It is washed on a sloping board seven feet long and three feet broad, covered with a woollen cloth, having a dish-shaped cavity at the upper end, and inclined to the horizontal plane at an angle of 20 or 25 degrees. Only a very scanty livelihood can be gained by this employment. It is carried on by the poorer classes of the country people, and in some districts by bands of the people called Gipsies. The King's Collectors buy the gold from the gold washers at a stated price, to the amount of more than 800 pounds weight annually. (x.)

BORNEO, an Island forming part of the Great East Indian Archipelago. Next to New Holland, which may be considered as a species of continent, it seems indisputably the largest in the known world. It reaches from about 7° north to 4° south latitude, and from 109° to 118° east longitude. Its length may be estimated at 750 miles, its greatest breadth at 600, and its average breadth at 350. It exhibits the usual insular structure, a mass of lofty mountains in the centre, sloping gradually down to level and alluvial tracts along the sea shore. It is watered by many fine rivers, of which those of Borneo Proper, Banjar Massin, and Passir, are navigable for more than fifty miles above their junction with the sea. All these rivers are understood by Dr Leyden to be derived from an immense lake in the interior, called the Sea of Manilla. It is more probable that they all rise from the mountainous district of greatest elevation. The interior of Borneo is covered with immense forests, filled with wild animals, particularly oran-outangs. A great part of the coast is marshy, so that it is in portions only that it displays the exuberance of tropical fertility. Of all the East Indian Islands, Borneo ranks lowest as to civilization and improvement. Nothing, perhaps, has tended so powerfully to check its progress as the

Born
Borneo.General
Description

Borneo. solid and unbroken form of its coasts, destitute of those large bays or inland seas, which have always proved the nursery of commerce.

The Portuguese discovered Borneo in 1526, though the superior wealth promised by the Spice Islands made it attract comparatively little attention. Yet they, as well as the Spaniards, the Dutch, and the English, formed establishments on different parts of the coast; but the small force defending them, and the fierce animosity of the natives, made their tenure generally of very short duration. The physical structure of Borneo, the vast forests, mountains, and jungles of the interior, obstruct communication between the different parts of its coast, as completely as if an extent of sea had intervened. It is thus split into a number of petty districts, entirely detached from each other, and which cannot be satisfactorily described, unless in detail. We shall consider, therefore, in this manner, the principal states, beginning with Borneo Proper, and thence making the circuit of the Island; after which, we shall attempt some general views of its population and commerce.

Northern Coast.

Borneo Proper occupies the northern coast, and is reckoned a state of great antiquity. The soil is comparatively fertile, supplying rice sufficient for the consumption of the inhabitants, as well as most of the camphire for which the Island is celebrated. The city, called also Borneo, is built upon alluvial ground, about ten miles above the mouth of the river of the same name. It is compared to Venice: canals are conducted through every street, and all business is conducted in boats, usually rowed by women. The houses are built upon posts, and ascended to by ladders. The river is navigable for large vessels considerably above the town; but there is a bar at its entrance, over which there is scarcely a depth of seventeen feet at high water. The Sultan is treated with those marks of peculiar respect which in this part of the world usually indicate an ancient dynasty; but the chief power rests in the council of the nobles. This state has little communication with Europeans; the English, who were accustomed to deal to a small extent in piece-goods, have in a great measure discontinued this traffic. The commerce of this city and district is almost entirely engrossed by the Chinese, who bring annually from Amou four or five junks, of about 500 tons burden. As the neighbourhood abounds in excellent timber, they frequently build their junks here, and carry them away loaded with the commodities of the country.

Eastern Coast.

On the eastern coast of Borneo, Mangedava and Pappal are populous, fertile, and well watered districts. Malloodoo possesses these advantages in a still superior degree, and grows also a large quantity of rattans. Tiroon produces sago in abundance, and birds' nests more copiously than any other part of the eastern Archipelago. None of these states, however, are much frequented by, or known to, Europeans.

The chief state on the eastern coast is Passir, situate about fifty miles up a river of the same name. This district is very low and flat; and, were it not cooled by the sea breezes, would be intensely hot. Being marshy and filled with woods, it is extremely unhealthy. The town is said not to contain above

300 wooden houses, which are built along the river. The Sultan has a palace and wooden fort, along the northern bank. The people of Passir have an extremely bad reputation as to their conduct in mercantile transactions. They use false weights and measures,—manufacture counterfeit articles,—and embrace, in short, every opportunity of cheating that offers. The English East India Company made an attempt, in 1772, to establish a factory here, but it did not succeed.

Borneo.

Banjar Massin is the principal state on the south-^{Southern} coast of Borneo; like the others, it owes its prosperity to a large river, on the banks of which it is situate. This river is five or six fathoms deep; but, unfortunately, the bar does not allow above 12 or 18 feet of water, and requires the aid of the tide to produce even that depth. Ships, however, may anchor in the port of Tombangou or Tombornio, near the mouth of the river, where they are well supplied with water and provisions. Banjar Massin, in 1780, was estimated to contain a population of 8500 Mahomedans, chiefly Javanese, with a considerable proportion of Bugis, Macassars, and Malays. The Chinese are also pretty numerous. The Sultan resides at Martapura, about three days' journey up the river, to which he is attached, by the circumstance of its being an uncommonly fine hunting station.

The district of Banjar produces gold and diamonds, both of superior quality to those found in other parts of the Island. Pepper is so abundant, that, in a commercial view, it may be considered as the staple commodity. The iron is very excellent, and peculiarly fit for steel; though Dr Leyden asserts, that the inhabitants do not, themselves, understand the art of manufacturing it.

In 1700, the English East India Company formed a settlement at Banjar Massin. A rage then prevailed for multiplying establishments, and the present one was soon so far extended, as to equal that of Calcutta. But the expectations of extensive trade, which prompted to such an enlargement, were, in a great measure, illusory; a thousand tons of pepper being the most valuable article drawn from the settlement. Before, however, the Company could be fully aware of its unproductive nature, this settlement was brought to a premature end. An attack was made by the natives on so great a scale, and with such fury, that, though repulsed, it seemed to leave no choice, but the immediate evacuation of the factory, without even removing the stores. The damage sustained on the occasion is estimated at 50,000 dollars.

Succadana, or, as Dr Leyden calls it, Sacadina, ^{Western} Coast. was anciently the most powerful state on the western coast of Borneo. The Dutch began to trade there in 1604, but they soon after attached themselves, in preference, to Sambia. In 1623, they abandoned their factory at Succadana. In 1786, they united with the Sultan of Pontiana in an expedition against this place, which they took and entirely destroyed. It appears to have been since rebuilt, but is entirely in the hands of the Malays, and scarcely ever visited by Europeans.

Pontiana is a state of very recent origin, but it now exceeds, in wealth and power, all others upon

Borneo.

the western coast of Borneo. This distinction it owes to the wisdom of the Arab Prince by whom it was founded. He renounced, from the first, the pernicious policy, almost universal in these petty states, of embarking in trade, and monopolizing its principal articles. He confined himself to his proper functions, of dispensing justice, and securing protection to all, of whatever country or religion, who resorted to his dominions. Under this salutary policy, Pontiana soon rose to be the greatest emporium in those seas. It is situate on a large river, called, formerly, Laua, and the country behind produces diamonds the most abundantly of any district in Borneo. The Dutch established a factory here in 1776, and maintained ever after a good understanding with the Sultan. In 1813, after the British force had taken possession of Batavia, that Prince, dreading an attack from Sambas, solicited the protection of a British garrison, which was immediately sent; and he afterwards assisted our troops in the reduction of Sambas.

Momparwa, situate a little to the north of Pontiana, is the best market for opium upon this coast. The city lies 19 miles up the river; the entrance of which is obstructed by a bar, and by several small Islands. This is probably the same district called Mattan by Dr Leyden, who says, that the King possesses the finest diamond in the world, for which a high price was offered by the Dutch, which he refused to accept.

Sambas is situate about 30 miles up the river of the same name. Like most other towns in Borneo, it is built of timber and bamboos, and raised by stakes above the swampy foundation. Sambas has been always a powerful state, but for sometime past, has devoted itself so entirely to piracy, as to render its existence scarcely compatible with that of its civilized neighbours. Upon this principle, the British, in 1812, undertook an expedition against it; but they were repulsed with great loss in the attack, and suffered still more from the malignant influence of the climate. In the following year, however, a new expedition was undertaken under Colonel Watson, who, on the 3d of July, carried the fort by storm, and obliged the Rajah to retire into the interior of his dominions. We presume, however, that both Sambas and Pontiana have been evacuated by the British troops, in consequence of the recent treaty with Holland.

Population
and Man-
ners.

On a general view of the state of culture and civilization in Borneo, Mr Hamilton estimates the population at 3,000,000, which we should suppose to be rather above than under the truth. The interior is entirely occupied by a native race, called variously, according to the parts of the Island which they inhabit, Dayak, Idan, and Tiroon. Those which subsist by fishing, are commonly called Biajoes. The appellations of Horaforas and Maroots, have also been applied to these races. The whole may be considered as one, almost savage, and nearly similar to that which occupies the interior of Sumatra. Some, indeed, cultivate the ground,—some display considerable industry in fishing,—and a few employ themselves in collecting gold; but their institutions, in general, indicate the very rudest state of human

Borneo.

society. It has been strongly reported, that they devour the flesh of their enemies; an assertion not noticed by Dr Leyden, and which has, in many instances, been made without foundation. All accounts agree, however, as to the existence of another truly savage custom, by which every man is debarred from the privilege of matrimony, till he has, with his own hand, cut off the head of an enemy. Those, therefore, who are desirous of entering into that state, form themselves into what Dr Leyden calls *head-hunting* expeditions. They make an inroad into the territories of a neighbouring tribe, and if their strength appears sufficient, endeavour to effect their object by force; if otherwise, they conceal themselves behind thickets, till an unfortunate individual passes, whom they can make their prey. Some are also said to immolate human victims on the altars of their divinities.

The inhabitants of the towns along the coast consist chiefly of that race so universally diffused through the Indian Islands, under the name of *Malays*. This name, to an European ear, has usually suggested every extreme of perfidy and atrocity. We have perused, however, a very different estimate of their character, formed by an intelligent gentleman, who spent several years in this part of India. He describes them as honest, frank, simple, and even gentle in their manners, decidedly superior, in a moral view, to the degenerate Hindoos. The sanguinary deeds, which have exposed them to so much reproach, he ascribes to a proud and almost chivalrous sense of honour, which makes them regard blows, or any similar personal insult, as an offence only to be expiated by blood. The coarse and unfeeling treatment which they often experience from Dutch and Chinese masters, drives them to these dreadful extremities. Piracy, however, is a vice of which this race cannot be acquitted; and the western coast of Borneo, situate on the great naval route to China, may be viewed as the grand field for its exercise. To a poor and hardy race, who see half the wealth of Asia passing along their shores, the temptation is almost irresistible. Like the Arabs, they have formed for themselves a code of morality, in which plunder is expunged from the list of vices. Yet, though individually brave, they possess no skill or discipline, which could render them formidable to an European crew. The cowardice of the Lascars, by whom Indian trading vessels are usually navigated, is the only circumstance which has made our trade suffer so severely from their ravages.

Next to the two classes above enumerated, the most numerous are the Chinese. These, by the gentleman above alluded to, are considered as the most valuable subjects whom an uncivilized state can receive into its bosom. The difficulty of finding subsistence in their own country, has led them to emigrate in vast numbers into Borneo. Nothing, perhaps, except the law which prohibits females from leaving the empire, could have prevented this almost unoccupied Island from being entirely filled with a Chinese population. From this circumstance, however, the colonists are composed entirely of men in the vigour of life, and of the most enterprising and industrious character. Their chief settlement

Borneo is at Sambaa, on the western coast, where the numbers cannot be estimated at less than 30,000, composing a sort of independent state. Their almost sole occupation is that of extracting the gold, which abounds upon this coast. It is found in alluvial soil, and is purified by the simple process of passing a stream of water over the ore. The processes employed for this purpose are daily improving, and it is conceived that the produce here and at other quarters, will be sufficient to remove all future apprehensions of the East proving a drain upon the gold of Europe.

Commerce. The Commerce of Borneo, though not equal to its extent and natural capacities, is by no means inconsiderable. Gold is its principal export. Mr Milburn estimates the annual quantity exported at 200 peculs, or 26,000 lbs. avoirdupois, which would coin into upwards of 900,000 guineas. Like some other commodities, it is divided, by a grotesque scale, into three kinds, called the head, the belly, and the feet; the first being the best, and the two others gradually diminishing in value. Camphire is exported to the extent of 30 peculs (3990 lbs.), all to China, where it is more esteemed than that of Sumatra. The singular Chinese luxuries of *beech de mer*, or sea slug, and edible *birds' nests*, are found in Borneo, as over all the Indian archipelago. Pepper to a considerable amount, canes and rattans of various descriptions, sago, and a little tin, complete the list of exports. The chief import is opium to a very great extent, with piece-goods, hard-ware, coarse cutlery, arms, and toys. By far the greater proportion of the trade is in the hands of the Chinese.

Leyden's *Description of Borneo*, in the *Asiatic Journal*; Hamilton's *Gazetteer*; Milburn's *Oriental Commerce*; MS. of a Gentleman long resident in India. (B.)

BORROMEAN ISLANDS. Not far from the south-east termination of the Alps, there is a lake called Lago di Locarno, or Lago Maggiore, extending above fifty miles in length, by five or six in breadth. It contains several islands, among which are, the Isola Bella and Isola Madre, situate in a large bay towards the west, and designed the Borromean Islands. Towards Switzerland, the lake terminates in a canal, which is of much utility for commercial purposes; and near Cesti, which is ten leagues from the city of Milan, it discharges itself into the river Ticino, with a current rapid and dangerous to the navigation of small vessels. The Borromean Islands lie about fifteen miles distant by water from Cesti, and the passage to them displays a succession of curious and interesting objects, some of which are connected with their own history. Among these may be named a colossal bronze statue of San Carlo Borromeo, above the small town and port of Arona, which is sixty feet in height, and stands on a pedestal of proportional dimensions. This gigantic image was cast at Milan, and brought hither in pieces. The Borromean Islands are of inconsiderable size, but the artificial decoration they have received, has been the admiration of spectators since the middle of the seventeenth century, when both were barren and unprofitable rocks. About this time Vitaliano, Count Borromeo, a nobleman of illustrious descent,

and Master-General of the Ordnance to the King of Spain, resolving on their embellishment, directed that they should be covered with earth from the neighbouring banks of the lake. His injunctions were fulfilled, and, at an immense expence, the Islands were converted into two gardens. Isola Madre appears in ten successive terraces, rising one hundred and thirty feet above the level of the water, each regularly decreasing in size from the base to the summit, which is an oblong surface, seventy feet by forty in extent, paved and surrounded by a balustrade. The whole are environed by gigantic marble statues of gods, goddesses, and horses, or other figures; and the walls are clothed with the finest fruit trees and evergreens, many of which belong to the southern climates. There is, besides, a magnificent palace towards the west end of the Island, close to the lake, which almost washes its walls. It is built on arches, which are formed into grottos, with a floor of Mosaic, representing various objects, and decorated also with shell-work and marble. The palace itself, contains a profusion of marbles and paintings, and some flower-pieces, executed on marble, have been particularly admired; as also busts and statues. At the angles of the garden, which has a southern exposure, there are two round towers with lofty chambers adorned with red and white marble; and in the vicinity are groves of laurels, orange-trees, lofty cypresses, and other odoriferous plants, rendering it a delightful retreat. But much of the embellishment is lost by the immediate neighbourhood of a miserable hamlet.

Isola Madre, which is the larger of the Islands, is between one and two miles from Isola Bella; it consists of a superstructure of seven terraces, apparently lower, but not less beautiful than the other. However, it is of equal height in reality; the base being a perpendicular rock, rising considerably out of the water, and on that account not having required so much covering. Here also there is a palace embellished with paintings and different ornaments; and in the gardens are groves of citrons, cedar, and orange-trees, besides a summer-house close to the lake. But all the decorations, as before, are necessarily on a limited scale from the size of the Island; and it excites the wonder of the spectator, that in a space so restricted, so much has been done. Pheasants were formerly bred in this Island, as they were deterred by the vicinity of the water on all hands from attempting to escape. There were some hydraulic exhibitions in Isola Bella, and large cisterns or reservoirs to preserve them in action. When any foreign Prince visited these Islands in the night, or resided upon them, they were illuminated with various coloured lights. Their decorations were not only completed at an enormous expence, but to keep them in the same state since 1671, about which time they seem to have been finished, the charge has proved equally great. They are frequently called the "Enchanted Islands." Keyser, a learned traveller, says, "these two Islands can be compared to nothing more properly than two pyramids of sweetmeats, ornamented with green festoons and flowers." And a later tourist, Coxe, who borrows largely from him, in speaking of the Isola Bella, observes, "if anything

Borromean
Islands.

Borromeo
Islands
|
Boswell.

justly gives this Island the appellation of enchanted, it is the prospect from the terrace. The gradual diminution of the mountains, from the regions of eternal snow to the rich plain; the sinuosity of the lake; its varied banks; the bay of Marzozzo, bounded by vast hills; the neighbouring borough of Palanza, and more distant view of Laveno, the numerous villages, the Isola Madre, and another Island sprinkled with fishermen's huts, form a delightful assemblage."

These Islands, after passing from the family of Borromeo, appear to have come into possession of the Emperor of Germany. More recently, both of them, together with the western coast of the bailliage of Locarno, are said to have been ceded by the Empress Maria Theresa to the King of Sardinia, in consideration of the assistance she had derived from him. The whole lake is environed by hills, covered with vineyards, and interspersed with summer-houses; beautiful rows of trees traverse its banks, and the scene is still farther embellished by cascades falling from the mountains. (s.)

BOSWELL (JAMES, Esq. of Auchinleck, in the county of Ayr), whose life of Dr Samuel Johnson entitles him to a place among those who have contributed to the great stock of intellectual wealth, was the eldest son of Alexander Boswell (styled Lord Auchinleck), one of the Judges of the Supreme Courts of Session and Justiciary in Scotland. He was born in the year 1740; and, having received the rudiments of his education, partly in his father's house, and partly at Mr Mundell's school in Edinburgh, successively prosecuted his studies at the Universities of that city and of Glasgow. He was destined by his father for the Scottish bar; a pursuit with which his own inclinations did not much accord, and in place of which, he would gladly have substituted one of greater activity and enterprise. His father's wishes, however, and his own sense of filial duty, prevailed; and, as the study of Civil Law, at one of the foreign Universities, was then included in the most liberal plan of education for a Scottish Advocate, it was determined that Mr Boswell should repair, for that purpose, to Utrecht; with a permission, before his return, to make the tour of Europe.

Already, however, those traits of character might be observed, which gave the peculiar direction to his after life. He was, very early, ambitious of being admitted into the society and friendship of men distinguished by talent and public estimation, more especially those of eminence in the literary world; and his natural urbanity, as well as gaiety of disposition, rendered it no difficult matter to gratify his propensity. While at the University of Glasgow, he had formed a particular intimacy with Mr Temple, the friend of Gray, afterwards Vicar of St Gluvias in Cornwall; and he was known to many of the conspicuous characters at that time in Scotland, among others, Lord Kames, Lord Hailes, Dr Robertson, and Dr Beattie. But the most remarkable acquisition which he made of this kind was his acquaintance with Dr Johnson,

which commenced in 1763, and was to prove at once the principal era in his own life, and the means of adding not a little to the fame of the philosopher. Boswell.

Mr Boswell had visited London, for the first time, in 1760, when he accidentally became acquainted with Derrick, afterwards King Derrick, as the Master of Ceremonies at Bath was then fantastically titled; and by him was initiated into the arcana of London life. In 1763 he proceeded to Utrecht. Having passed a year at that university, he travelled into Germany and Switzerland, was entertained by Voltaire at his castle of Ferney, and conversed with Rousseau in the solitudes of Neufchatel. He continued his route to Italy; but, led by his natural enthusiasm, forsook the common roads of travel, and passed over to Corsica, which, after a contest of more than thirty years, was still struggling for independence with the republic of Genoa. He thus describes his feelings while he approached the island: "As long as I can remember anything, I had heard of the malecontents of Corsica; it was a curious thought that I was just going to see them." Rousseau had given him a letter of introduction to the romantic Paoli; and his tide was suddenly at the full. In the small court of this simple but dignified Chieftain, he found everything to gratify his taste for the virtuous and sublime in natural character. He became a favourite, too, in his turn; was caressed by the islanders, admitted at all times to the society of their leader, and not only witnessed the movements of their political machinery, but appeared to be himself an actor in the scene. Of his visit to this island, he published a narrative on his return to Scotland, entitled, *An Account of Corsica, with Memoirs of General Pasquale de Paoli*, printed at Glasgow in 1768. This book was translated into the Dutch, German, French, and Italian languages. He likewise printed, in the following year, a collection of *British Essays in favour of the Brave Corsicans*; and made such attempts as he could to interest the British Government in favour of that people, before they were finally crushed by the pressure of the French arms. His acquaintance and friendship with General Paoli were afterwards renewed in London, when that chief, having escaped with difficulty from his native isle, found an asylum in the British dominions.

From Corsica Mr Boswell repaired to Paris; and, returning to Scotland in 1766, was admitted to the bar. Soon after he published a pamphlet, under the title of *Essence of the Douglas Cause*; written while that great suit was depending in the Court of Session, with a view to excite the public interest in favour of Mr Douglas. In 1769 he was married to Miss Montgomery, daughter of David Montgomery, Esq.; an accomplished lady, in whose society he enjoyed every domestic happiness.*

In the year 1773 Mr Boswell was admitted into the Literary Club, which then met at the Turk's Head in Gerard Street, Soho, and of which Dr Johnson had been an original member. Here he

* He had a family by her of two sons and three daughters. Mrs Boswell died in 1790.

Boswell. had the pleasure of associating, among others, with Burke, Goldsmith, Reynolds, and Garrick.

Dr Johnson had long projected a tour to the Hebrides; and Mr Boswell at last prevailed upon him, in the course of this year, 1773, to put the plan in execution, and became the companion of his journey from Edinburgh. During this excursion, they saw whatever was most remarkable in the Western Highlands and Isles; and here Mr Boswell was again at large in his natural element. Conscious of the advantages which he enjoyed, and aware of their value, he improved every opportunity of knowledge and remark, and has preserved a faithful record of all. His feelings were like those which Dante ascribes to the pilgrim, who, having paid his vows,

“ Long gazes on the holy fane, and thinks
How he shall paint it when he reaches home.”

Both travellers gave the world an account of this tour. Mr Boswell's *Journal* was published in 1785. In the course of this work, he has given a simple and very interesting narrative of some minute circumstances attending the escape of Prince Charles Edward after the battle of Culloden, collected from the information of persons on the spot, and privy to his concealment; particularly from the celebrated Flora Macdonald, whom they visited at Kingsburgh, in Sky, and from Malcolm Macleod, who had been the faithful and intelligent companion of the Wanderer's flight.

Lord Auchinleck died in 1782; and, a few years after (1786), Mr Boswell, giving up his law pursuits at Edinburgh, removed with his family to London, towards which, as a great emporium of literature and theatre of varied life, his inclinations had always tended. He had recently before been called to the English bar. He did not, however, prosecute the profession, but gave himself up to his natural bent for society and letters. After Dr Johnson's death, in 1794, he was occupied for several years in collecting and arranging, with indefatigable diligence, the materials for a narrative, which he had long projected, of that eminent man's life.*

Besides the works which have been already mentioned, he was the author of two Letters addressed to the People of Scotland; being his only productions of a political character. In the first of these, which was published in 1784, he appeared as an advocate for the new administration, then recently formed. The second Letter, written in 1785, was a strenuous appeal against a measure brought forward under the sanction of the same ministry, for effecting a reform in the Court of Session in Scotland, by reducing the number of the Judges.

Mr Boswell died on the 19th June 1795. In his private character, he was loved by his friends, as well as a favourite in the circles of social life; and, if his attachments were often suddenly formed, they were not less durable on this account. Whatever

he has written is favourable to virtue; and, during a course of living which naturally dissipates the mind, his moral principles remained entire, and his religious faith unshaken. “ Few men,” says his friend Sir William Forbes, in a Letter published in his *Life of Dr Beattie*, “ possessed a stronger sense of piety, or more fervent devotion—perhaps not always sufficient to regulate his imagination, or direct his conduct, yet still genuine, and founded both in his understanding and his heart.” His talents would probably have been rated higher, if they had not been obscured by certain eccentricities of character. Yet his writings bear sufficient testimony to his natural abilities, and to the delicacy as well as aptness of his intellectual touch. He has described himself as being of a temperament inclined to melancholy; but in society he was remarkable for the gaiety of his disposition, and his life was full of activity and stir. To be distinguished was his ruling passion, and he indulged it freely. He sought those whom the world, on whatever account, held in honour; and was desirous of being known as one with whom they assorted, and who possessed their friendship. He was fond of his pedigree and family connections, and he aspired after literary fame. While some of these propensities have been common to the great and good in every age, others, it must be confessed, are more frequently harboured than avowed. Mr Boswell adopted the latter and more unusual course. † He fairly owned his passion, and, if not thus secured from attack, had all those advantages, at least, which are gained by meeting an enemy in the field. But, in reality, he has dealt so openly, and with such candour, on every occasion which touches himself as well as others, that he wins not only our forgiveness but our affection, and maintains, by ingenuousness and complete truth of character, a kind of superiority over any person who should feel desirous of assailing him. Nor was evidence of a substantial sort wanting to show the independence of his mind. For, however attached to individuals of extensive influence, and however ambitious of exalted patronage, he was neither an instrument of party, nor a server of the time. What he gave in attention, he received back in kindness; and, while he associated with the learned and the philosophical, he contributed his share to the general stock of enjoyment. Of Dr Johnson's sincere attachment to him, there are many and unequivocal proofs in their correspondence.

But it is not on account of his private character, or of a certain domestic celebrity which he enjoyed during his life, that he is to be distinguished in a work of this kind. We commemorate him as an author, and particularly as a writer of Biography. Here he is almost an inventor; he has, at least, carried this species of composition to a degree of accuracy and detail formerly unattempted. Other writers, as the Abbé de Sade, in his *Memoirs of Petrarch*, and Mason, in his *Life of Gray*, had conducted the

* *Life of Samuel Johnson*, LL.D. 2 vols. 4to. London, 1791.

† “ Egotism and vanity,” says he, in his Letter published in 1785, “ are the indigenous plants of my mind: they distinguish it. I may prune their luxuriancy, but I must not entirely clear it of them; for then I should be no longer as I am, and perhaps there might be something not so good.”

Boswell. course of their narratives partly by means of original letters. But Mr Boswell has, more than any preceding Biographer, made use of all the varied means by which such a history admits of being dramatized. He paints the whole man, presents the incidents of his life in their actual order of succession, and preserves him as it were entire; fulfilling in the history of the moral, what Bacon has assigned to Philosophy as her genuine work in that of the natural, world, faithfully to return its accents and reflect its image, neither to add any thing of her own, but iterate only and repeat.

The plan of keeping a Miscellaneous Journal had been recommended to him by Dr Johnson, on their first acquaintance; and he appears very early to have followed it, so far as writing down what was remarkable in the conversation of those whom he admired. From his frequent allusions to the discourses of Selden, commonly called his *Table Talk*, as preserved by Lilward, it is probable that he had the example of that work in his view; and by long use he acquired a great facility in this process. Of his first publication, containing an account of Corsica, the Journal of his residence with General Paoli is by far the most interesting part. It is a sketch remarkable for life and natural colouring; and is one of those productions which, though enhanced by their occasion, do not depend on this circumstance alone for the attraction which they possess. In his *Journal of a Tour to the Hebrides*, he pushed to a still greater extent, and even beyond its just limits, his favourite style of writing. Carried away by his natural enthusiasm, and delighting "to pour out all himself, like old Montaigne," he indulged in a more ample and unqualified disclosure, both of his own sentiments and of the opinions of others, than is consistent with a salutary prudence, or necessary for the purposes of instruction. Of this he himself became sensible, on cooler reflection, and not only acknowledged it with candour, but in his subsequent and more laboured compositions, profited by the general opinion, and imposed a greater restraint upon his pen.

For the task of writing Johnson's life he was in many respects peculiarly qualified. He had lived in habits of intimacy with the Sage for a period of twenty years, had early conceived the plan of such a work, and received from Johnson himself, to whom his intention was known, many particulars of his early life and personal history. As the writer was thus furnished for his undertaking, so there has seldom been a more fertile or interesting subject for the Biographer. Johnson was not a mere scholar, "deep versed in books, and shallow in himself," nor was he one of those unprofitable misers who hoard without expending. He was a general and a minute observer, and, while he possessed in a degree seldom equalled "the strenuous use of profitable thought," his talent for communicating knowledge was more remarkable even than the large capacity of his mind, or the accumulation of his learning.

According to Baker's character of King James, in

that passage which Mr Boswell happily prefixed to his *Journal*, "he was of an admirable pregnancy of wit, and that pregnancy much improved by continual study from his childhood, by which he had gotten such a promptness in expressing his mind, that his extemporal speeches were little inferior to his premeditated writings. Many, no doubt, had read as much, and perhaps more than he, but scarce ever any concocted his reading into judgment, as he did." Johnson's conversation, accordingly, is the matter and substance of the book; and, as the Philosopher did not, in the midst of his studies, forget to cultivate his friends, nor gave up the advantages and comfort of society, there was in his discourse a range and diversity of subject not often found in combination with classical knowledge and habits of profound thinking. Nor does this work exhibit a series merely of witty and sententious sayings; it is interspersed alike with miscellaneous narrative and criticism; and, which constitutes its principal feature, it contains a mass of opinions on subjects of a more common nature, where the powers of reasoning and illustration are applied to familiar topics, and the ordinary occurrences of life. Valuable as a deposit of literary anecdote, it is still more so as a collection of ethical discourses, to which its popular form gives a singular currency and effect; so that there are few books extant where the religious and social duties, as well as the love of science, in its largest acceptation, are impressed more agreeably, or with greater force, upon the mind.

Among the many circumstances which have conspired to heighten our interest in this narrative, is the exhibition which it affords of illustrious characters in different walks of life. The period was distinguished by an unusual measure of genius and talent; and we are not only introduced to the closet of the Philosopher, but carried with him also into assemblages of the brilliant and the wise, with whom he associated. The tone of this society, moreover, is highly pleasing, and in harmony with our best principles and feelings; in which respect, it is impossible to avoid contrasting it with those more boasted Parisian societies during the same period, which were supposed to be the centre of French literature and wit, as they are displayed to us by some of the chief actors in that scene.* Mr Boswell's work has not yet, indeed, acquired all its interest; the period is still too recent; but, to estimate its value in after times, we have only to consider what we ourselves should have gained, if such a volume had been preserved to us from the rolls of ancient life.

In the great attainments of a Biographer, which are the truth and minuteness of his relation, Mr Boswell has been eminently successful. If, in this species of writing, an author is exempted from the formality, as well as comprehensive research, necessary in the higher classes of historical composition, it is well known that he has his peculiar difficulties to encounter; difficulties, too, which are the greatest where, by his intimate knowledge of the subject, he is best qualified for the task of writing. Nor does

* Particularly in the *Correspondence of the Baron de Grimm*, and the *Memoirs of Marmontel*.

Boswell.

the partialty to which he is himself exposed constitute his only danger; since he is no less apt to be led away by the expectation of gratifying his readers. We are fond of seeing the picture of character completed according to our fancy; and, whatever be the feeling which has commenced, are impatient of any interruption to its train. In the case of those whom we respect and love, the disappointment is doubly ungrateful; we dislike being told of their frailties, because we are unwilling to believe that they were frail. But such is not the colour nor the tissue of human characters; and the artist who would represent them truly, must do perpetual violence to his inclination. The fidelity of Mr Boswell's portrait may be ascribed, in a great measure, to the form and method of his composition. Had he given us only the results of his observation, the effort at impartiality could scarcely have been preserved; but he has presented us with the whole materials as he found them, and allows us to work them up for ourselves.

In the other distinguishing quality of a Biographical work, namely, the minuteness of its information, he is so little deficient, that his observance of this requisite has been converted into an accusation against him. And it is certain, as already observed, that, in his early productions particularly, he left some room for such a charge; and that, while his veracity and candour were unimpeached, his prudence was not on all occasions equally conspicuous. Yet it must be remembered, that the great use of Biography is to bring instruction home; to give us examples, not of individual actions and conduct merely, but of that conduct as displayed in the common paths of life. The history of nations is too often a species of heroical romance. Its lessons are, at all events, of a different nature from those now in question, and its moral is far too remote to answer the necessities of individuals. General precepts, again, when delivered without the aid of story, commonly fail to produce their effect, either because they fail to excite attention, or because the power of applying them to particular cases remains difficult as before. Nor do works of fiction, however excellent, and even where the scene is laid as it were at home, and the characters are those of a private station, leave any very permanent impressions on the mind. They do not carry with them a sufficient presence and authority; for, the writer's first object is, not to instruct but to please; and, above all, they want that great requisite, truth, for which, in the time of need, all others are abandoned and forgot. A manual of instruction for human conduct, which, instead of being couched in general maxims, or calculated for situations of unusual occurrence, should

Boswell.

descend to particular cases, and to the ordinary emergencies of private life, would certainly be one of the most valuable presents which Philosophy could offer to the bulk of mankind. Biography makes the nearest approach towards the compilation of such a code; and, as a commentary on moral duties, it is, when faithfully executed, invaluable. But it is so in proportion only to the closeness of the resemblance, and the exactness of the detail. Minuteness, therefore, is the characteristic and soul of biographical writing, if its proper uses are considered.

That such a plan of delineation may be carried to excess, indeed, is undeniable. He who is accustomed to set down whatever he sees and hears, may become indiscriminate in his choice, and forget the value of his store, in the pleasure of collecting it. To ascertain the just medium in this respect, is one of the many things for which rules are ineffectual. A sound judgment alone can determine the limits. As to the licence of publication, the Biographer is under one common restraint with authors of every class. He violates the due boundary, if he introduces into his work what is injurious to virtue, or, if he discloses, for the purposes of general information merely, anything which may probably affect the interests, or wound the minds, of the living. When that period has arrived which secures against dangers of the latter description, even individual characters become, to a certain extent, the property of mankind at large, and may be employed as a vehicle for instruction, if exhibited with fidelity. On this score, Mr Boswell, notwithstanding his natural promptness and want of reserve, has, in his latest and principal work at least, given little ground for animadversion. His habitual quickness of feeling and liveliness of fancy appear to have been corrected, where others were concerned, by his love of justice, and a general benevolence of mind.

With regard to his style of writing, a progressive improvement in it may be discovered through his different productions. It is, in general, well suited to his matter, is animated and easy where he is himself the narrator, and bears evident marks of being true to the original, where, as commonly happens, he is a reporter merely. On the whole, whatever blemishes may be found in it as a literary composition, his *Life of Johnson* is a very valuable work, fraught with information at once useful and pleasing. There are few books which present learning in a more attractive form; and few where the seeds of knowledge are scattered more profusely.

See the *Gentleman's Magazine*. Chalmers's edition of the *Biographical Dictionary*, 1812; and the writings of Mr Boswell, *passim*. (xx.)

BOTANY.

Botany.

THE Linnæan System of Botany, the principles upon which it is founded, with its application to practice, have all been amply elucidated in the fourth volume of the *ENCYCLOPÆDIA BRITANNICA*. The reader will there find a general view of this celebrated system, including the generic characters, as well as some of the specific differences, of most plants hitherto discovered, with their qualities and uses. The terminology of Linnæus is explained; his arguments for the existence of sexes in flowers are detailed; his ideas of a natural method of classification, and of its utility in leading to a knowledge of the virtues of plants, are subjoined to a compendious history of Botanical Science.

Objects of this Article.

The writer of the present supplementary article proposes to take a different view of the subject. This study has, within twenty or thirty years past, become so popular, and has been cultivated and considered in so many different ways, that no dry systematic detail of classification or nomenclature is at all adequate to convey an idea of what Botany, as a philosophical and practical pursuit, is now become. The different modes in which different nations, or schools, have cultivated this science; the circumstances which have led some botanists to the investigation of certain subjects more than others; and the particular success of each; may prove an amusing and instructive object of contemplation. In this detail, the history of scientific Botany will appear under a new aspect, as rather an account of what is doing, than what is accomplished. The more abstruse principles of classification will be canvassed; and the attention of the student may incidentally be recalled to such as have been neglected, or not sufficiently understood. The natural and artificial methods of classification having been, contrary to the wise intention of the great man who first distinguished them from each other, placed in opposition, and set at variance, it becomes necessary to investigate the pretensions of each. The natural method of Linnæus may thus be compared with his artificial one, and as the competitors of the latter have long ceased to be more than objects of mere curiosity, we shall have occasion to show how much the rivals of the former are indebted to both. In the progress of this inquiry, the writer, who has lived and studied among the chief of these botanical polemics, during a great part of their progress, may possibly find an occasional clue for his guidance; which their own works would not supply. No one can more esteem their talents, their zeal, and the personal merits of the greater part, than the author of these pages; but no one is more independent of theoretical opinions, or less dazzled by their splendour, even when they do not, as is too often the case, prove adverse to the discovery of truth. Nor is he less anxious to avoid personal partiality. *In corruptam fidem professis, nec amore quisquam, et sine odio, dicendus est.*

About the end of the seventeenth century, and the

beginning of the eighteenth, the necessity of some botanical system, of arrangement as well as nomenclature, by which the cultivators of this pleasing science might understand each other, became every day more apparent. Nor was there any deficiency of zeal among the leaders and professors of this science. Systems, and branches of systems, sprung up over the whole of this ample field, each aspiring to eminence and distinction above its neighbours. Many of these, like the tares that fell by the way side, soon withered for want of root; others, like the *herba impia* of the old herbalists, strove to overtop and stifle their parents; and all armed themselves plentifully with thorns of offence, as well as defence, by which they hoped finally to prevail over their numerous competitors. This state of scientific warfare did not, in the mean while, much promote the actual knowledge of plants, though it prepared the way for a final distribution of the numerous acquisitions, which were daily making, by the more humble, though not less useful, tribe, of collectors and discoverers. The success of the Linnæan artificial system is not altogether, perhaps, to be attributed to its simplicity and facility; nor even to the peculiar attention it commanded, by its connection with the striking phænomenon, brought into view at the same time, of the sexes of plants. The insufficiency, or at least the nearly equal merits, of the many other similar schemes that had been proposed, began to be most strongly felt, just at the time, when the great progress and success of practical botany, rendered the necessity of a popular system most imperious. While the cause of system was pending, some of the greatest cultivators of the science were obliged to have recourse to alphabetical arrangement. This was the case with Dillenius, the man who alone, at the time when Linnæus visited England, was found by him attentive to, or capable of understanding, the sound principles of generic distinction. These he probably understood too well to presume to judge about universal classification. It was the fashion of the time however for every tyro to begin with the latter; and the garden of knowledge was consequently too long encumbered with abortive weeds.

Linnæus had no sooner published and explained his method of arranging plants, according to that which is generally termed the Sexual System, than it excited considerable attention. His elegant and instructive *Flora Laponica* could not be perused by the philosopher or the physician, without leading its readers occasionally aside, from the immediate objects of their inquiry, into the paths of botanical speculation, and awakening in many a curiosity, hitherto dormant, on such subjects. But the scope of that limited Flora is by no means sufficient to show either the necessity or the advantages of any mode of arrangement. Linnæus may be said to have grasped the botanical sceptre, when, in the year 1753, he published the first edition of his *Species*

Necessity of a Botanical System.

Services rendered by Linnæus.

Botany, *Plantarum*; and the commencement of his reign must be dated from that period. The application of his system to universal practice, in this compendious distribution of all the known vegetables of the globe; his didactic precision; his concise, clear, and certain style of discrimination; his vast erudition displayed in synonyms; and, perhaps as much as any thing else, the fortunate invention of trivial or specific names, by which his nomenclature became as evidently commodious, and indeed necessarily popular, as any part of his performance; all these causes co-operated to establish his authority. An immediate impulse was given to practical botany. The vegetable productions of various countries and districts were marshalled in due array, so as to be accessible and useful. A common language was established throughout the world of science; a common stock of knowledge and experience began to accumulate, which has ever since been increasing, and can now never be lost. Of these partial Floras to which we allude, those of Lapland and Sweden, the productions of Linnæus himself, were the models of most of the rest, and have never, on the whole, been excelled.

Linnæan School

Hence arose the Linnæan school of Botany, which though founded in Sweden, extended itself through Holland, Germany, and more or less perfectly in other parts of Europe, though not without impediments of which we are hereafter to speak. In Britain it was firmly established, by the influence of some of the most able pupils of Linnæus, and strengthened at length by the acquisition of his literary remains. But these are adventitious supports. The strength of philosophical, like political, authority is in public opinion, and the cement of its power is public good.

As we proceed to trace the practical influence of the Linnæan system, or rather of the facility which it afforded, in botanical studies, it will be useful at the same time to observe the effects of adventitious circumstances, which render botany almost a different sort of study in different parts of the habitable globe.

Botany of the North.

In those northern ungenial climates, where the intellect of man indeed has flourished in its highest perfection, but where the productions of nature are comparatively sparingly bestowed, her laws have been most investigated and best understood. The appetite of her pupils was whetted by their danger of starvation, and the scantiness of her supplies trained them in habits of economy, and of the most acute observation. The more obvious natural productions of such climates are soon understood and exhausted. But this very cause led Linnæus to so minute a scrutiny of Swedish insects, as had never been undertaken before in any country; in consequence of which a new world, as it were, opened to his contemplation, and the great Reaumur declared that Sweden was richer in this department than all the rest of the globe. Such indeed was its appearance, because it had been more carefully examined. When the ardour and acuteness of the pupils of the Linnæan school first sought matter of employment for their talents, some few had the means of visiting distant, and scarcely explored, countries; but this

VOL. II. PART II.

Botany. could not be the lot of many. The greater part were confined to their native soil; and it is remarkable that those who were longest so confined, have displayed in the sequel the greatest abilities, and have rendered the greatest services to science, independent of the accidents which made the labours of others imperfect or abortive. Such men as Ehrhart and Swartz were not to be satisfied with the general productions of the fields or gardens to which they had access. They had no resource but in the recondite mysteries of cryptogamic botany, in the first instance. To these they directed their microscopic eyes, and more discriminating minds, with the happiest success. When they had derived from hence Ehrhart an ample harvest, Ehrhart, limited in circumstances and opportunities, hindered moreover perhaps, in some degree, by a singularity and independence of character, not always favourable to worldly prosperity, opened to himself a new path. The native trees of the north, and especially the hardy shrubs and arborecent plants of the gardens, had not, as he judiciously discovered, received that correct attention, even from his master Linnæus, which was requisite to make them clearly understood. Difficulties attending the study of these plants, the various seasons in which they require to be repeatedly scrutinized, and the obscurity or minuteness of the parts on which their differences depend, were by no means calculated to deter this laborious and accurate inquirer. He submitted the supposed varieties of the shrubbery, the kitchen garden, and even of the parterre, to the same rigorous examination, and, for the most part, with the happiest success. His discoveries have not received the notice they deserve, for his communications were deformed with asperity and pedantry, and he did not always keep in mind the concise and sober principles of definition, which his preceptor had both taught and practised, and to which he owed so large a share of his well-merited fame. Ehrhart died prematurely, but his name ought to be cherished among those whose talents have advanced science, and who loved Nature, for her own sake, with the most perfect disinterestedness.

The fate of Swartz has been far more propitious Swartz: to himself and to the literary world. Having thrown more light upon the cryptogamic productions of Sweden and Lapland than they had previously received, and which has only been exceeded by the more recent discoveries of the unrivalled Wahlenberg, he undertook a botanical investigation of the West Indies. Carrying with him, to this promising field of inquiry, so great a store of zeal and practical experience, his harvest was such as might well be anticipated. Whole tribes of vegetables, which the half-learned or half-experienced botanist, or the superficial gatherer of simples or flowers, had totally overlooked, now first became known to mankind. Tropical climates were now found to be as rich as the chill forests and dells of the north, in the various beautiful tribes of mosses; and the blue mountains of Jamaica rivalled its most fertile groves and savannas in the beauty, variety and singularity of their vegetable stores.

Nor must we pass over unnoticed the discoveries Thunberg.

3 B

Botany. of another illustrious disciple of Linnæus, the celebrated Thunberg, who has, now for many years, filled the professorial chair of his master, with credit to himself and advantage to every branch of natural science. The rare opportunity of examining the plants of Japan, and of studying at leisure the numerous and beautiful productions of the Cape of Good Hope, as well as of some parts of India, have thrown in the way of Professor Thunberg a greater number of genera, if not species of plants, than has fallen to the lot of most learned botanists; except only those who have gone round the world, or beheld the novel scenes of New Holland. These treasures he has contemplated and illustrated with great advantage, so far as he has confined himself to practical botany. We lament that he ever stepped aside to attempt any reformation of an artificial system. It is painful to complain of the well-meant, though mistaken endeavours of so amiable and candid a veteran in our favourite science; but what we conceive to be the interests of that science must form our apology. We cannot but be convinced, and the experience of others is on our side, that discarding those principles of the Linnæan system which are derived from the situation of the several organs of impregnation, and making number paramount, has the most pernicious and inconvenient effect in most respects, without being advantageous in any. This measure neither renders the system more easy, nor more natural, but for the most part the reverse of both. We have elsewhere observed, (*Introduction to Botany*, ed. 3. 358,) that the amentaceous plants are of all others most uncertain in the number of their stamens, of which Linnæus could not but be aware. "Even the species of the same genus, as well as individuals of each species, differ among themselves. How unwise and unscientific then is it, to take as a primary mark of discrimination, what nature has evidently made of less consequence here than in any other case!" When such plants are, in the first place, set apart and distinguished, by their monoecious or dioecious structure, which is liable to so little objection or difficulty, their uncertainty with respect to the secondary character is of little moment; their genera being few, and the orders of each class widely constructed as to number of stamens. Linnæus, doubtless, would have been glad to have preserved, if possible, the uniformity and simplicity of his plan; but if he found it impracticable, who shall correct him? Such an attempt is too like the entomological scheme of the otherwise ingenious and able Fabricius. The great preceptor having arranged the larger tribes of animals by the organs with which they take their various food, and which are therefore accommodated to their several wants, and indicative of even their mental, as well as constitutional, characters, Fabricius his pupil would necessarily extend this system to insects. But nothing can be more misapplied. Feeding is not the business of perfect insects. Many of them never eat at all, the business of their existence through the whole of their perfect state, being the propagation of their species. Hence the organs of their mouth lead to no natural distinctions, and the characters deduced therefrom prove, moreover, so difficult,

that it is notorious they could not generally be applied to practice by Fabricius himself, he having, in the common course of his studies, been chiefly regulated by the external appearance of the insects he described. This external appearance, depending on the form and texture of their wings, and the shape of their own peculiar organs, the *antennæ*, affords in fact the easiest, as well as the most natural, clue to their arrangement and discrimination.

As we presume to criticise the systematic errors of great practical observers, it cannot but occur to our recollection how very few persons have excelled in both these departments. Ray, Linnæus, and perhaps Tournefort, may be allowed this distinction. We can scarcely add a fourth name to this brief catalogue. The most excellent practical botanists of the Linnæan school have been such as hardly bestowed a thought on the framing of systems. Such was the distinguished Solander, who rivalled his preceptor in acuteness of discrimination, and even in precision and elegance of definition. Such is another eminent man, more extensively conversant with plants, more accurate in distinguishing, and more ready in recollecting them, than almost any other person with whom we have associated. Yet we have heard this great botanist declare, that however he might confide in his own judgment with regard to a species, or a genus of plants, he pretended to form no opinion of classes and orders. Men of so much experience know too much, to be satisfied with their acquirements, or to draw extensive conclusions from what they think insufficient premises. Others, with a quarter of their knowledge, find no difficulty in building systems, and proceed with great alacrity, till they find themselves encumbered with their own rubbish; happy if their doubts and uncertainties will afford them a tolerable screen or shelter! But we here anticipate remarks, which will come with more propriety hereafter. We return from the consideration of the labours of particular botanists, to that of the diversities of nature and circumstance.

While it is remarked that in the cold regions of the north, the skill of the deep and learned botanist is chiefly exercised on the minute and intricate cryptogamic tribes, we are not to infer that Nature is not every where rich in beauty and variety. Mosses and Lichens afford inexhaustible amusement and admiration to the curious inquirer, nor are more gorgeous productions entirely wanting. Even Lapland boasts her *Pedicularis Sceptrum*, never seen alive out of her limits, and Siberia offers her own beautiful crimson *Cypripedium*, to console for a moment the miserable banished victims of Imperial caprice. Kotzebue, though ignorant of botany, did not pass this lovely plant unnoticed, even in the height of his distress. The authoress of the pleasing little novel called "Elizabeth," has represented in a just light the botanic scenery of that otherwise inhospitable country; yet it must be allowed that its rarities are not numerous, except perhaps in those microscopic tribes already mentioned.

Let us in imagination traverse the globe, to a New ^{the} land. country where the very reverse is the case. From the representations, or accounts, that have been given of New Holland, it seems no very beautiful or pic-

Botany. turesque country, such as is likely to form or to inspire a poet. Indeed the dregs of the community which we have poured out upon its shores, must probably subside, and purge themselves, before any thing like a poet, or a disinterested lover of nature, can arise from so foul a source. There seems however to be no transition of seasons, in the climate itself, to excite hope, or to expand the heart and fancy; like a Siberian or Alpine spring, bursting at once from the icy fetters of a sublime though awful winter. Yet in New Holland all is new and wonderful to the botanist. The most common plants there are unlike every thing known before, and those which, at first sight, look like old acquaintances, are found, on a near approach, to be strangers, speaking a different language from what he has been used to, and not to be trusted without a minute inquiry at every step.

Cape of Good Hope. The botany of the Cape of Good Hope, so well illustrated by Thunberg, and with whose treasures he scattered a charm around the couch of the dying Linnæus, most resembles that of New Holland. At least these countries agree in the hard, rigid, dwarfish character of their plants. But the Cape has the advantage in general beauty of flowers, as well as in a transition of seasons. After the dry time of the year, when every thing but the *Aloe* and *Mesembryanthemum* tribes is burnt up, and during which innumerable bulbs are scattered by the winds and driving sands, over the face of the country, the succeeding showers raise up a new and most beautiful progeny from those bulbs. The families of *Ixia*, *Gladiolus*, *Iris*, *Antholyza*, *Oxalis*, and many others, then appear in all their splendour. Some of them, the least gaudy, scent the evening air with an unrivalled perfume, whilst others dazzle the beholder with the most vivid scarlet or crimson hues, as they welcome the morning sun.

Alpine and Tropical Botany. The lovely Floras of the Alps and the Tropics contend, perhaps most powerfully, for the admiration of a botanist of taste, who is a genuine lover of nature, without which feeling, in some degree of perfection, even botany can but feebly charm. Of one of these the writer can speak from experience; of the other only by report; but he has had frequent opportunities of remarking, that the greatest enthusiasts in the science, have been alpine botanists. The expressions of Haller and Scopoli on this subject go to the heart. The air, the climate, the charms of animal existence in its highest perfection, are associated with our delight in the beauty and profusion of nature. In hot climates, the insupportable languor, the difficulty of bodily exertion, the usual ill health, and the effects of unwholesome instead of salutary fatigue, are described as sufficient to counterbalance even the pleasure which arises from the boundless variety, and infinite beauty, of the creation around. The flowery trees of a tropical forest raise themselves far above the human grasp. They must be felled before we can gather their blossoms. The insidious and mortal reptile twines among their boughs, and the venomous insect stings beneath their shade. We who enjoy the productions of these climates in peace and safety in our gardens, may well acknowledge our obligations to

Botany. the labour and zeal of those who, by arduous journeys and painful researches, supply us with the riches of every country in succession. We do not, indeed, enjoy them in perfection, but we can study and investigate at leisure their various beauties and distinctions. We can compare them with our books, and profit by the acuteness of former observers. We can perpetuate, by the help of the pencil or the pen, whatever is novel or curious. We can preserve the plants and flowers themselves for subsequent examination, and return to them again and again in our closet, when winter has fixed his seal on all the instruction and pleasure afforded by the vegetable creation abroad. Yet let not the sedentary botanist exult in his riches, or rejoice too heedlessly in the abundance of his resources. A plant gathered in its native soil, and ascertained by methodical examination, is more impressed on the memory, as well as more dear to the imagination, than many that are acquired with ease, and named by tradition or report. The labours of its acquisition and determination enhance its value, and the accompaniments of delightful scenery, or pleasing society, are recollected, when difficulties and toils are forgotten.

The western continent is, with respect to Botany, America, almost a world in itself. There exists, indeed, a general affinity between the plants of North America and those of Europe, and many species of the arctic regions, are the same in both; but there are few common to the more temperate climates of each. A considerable number communicated by Kalm to Linnæus, which the latter considered as identified with certain well-known plants of our quarter of the world, prove, on more accurate examination, to be corresponding, but distinct species. Instances occur in the genera of *Carpinus*, *Corylus*, *Quercus*, as well as in the *Orchis* tribe, and others. These points of resemblance are found mostly among the vegetable productions of the eastern regions of North America. Mexico, and what little we know of the intermediate space, abound with different and peculiar productions. So, in South America; Peru, Guiana, Brasil, &c. have all their appropriate plants, of which we know as yet enough to excite our curiosity, rather than to satisfy it. Whatever has hitherto been given to the world respecting American botany has had one considerable advantage. Each *Flora* has been founded on the knowledge and experience of some one or more persons, long resident, and in a manner naturalized; in the countries illustrated. Those regions commonly comprehended under the name of North America, have afforded materials for the *Flora Boreali-Americana* of Michaux, and the more complete and correct *Flora Americæ Septentrionalis* of Pursh. Michaux, Wangenheim, and Marshall, have particularly illustrated the trees of those countries. But all these works have been enriched by the communications and assistance of men who had much more extensive and repeated opportunities of observation than their authors, except Mr Marshall, could have. Such are the venerable John Bartram, the Reverend Dr Muhlenberg, Messrs Clayton, Walter, Lyon, &c. The Mexican *Flora* has received, for a long course of years, the attention of the able and learned Mutis, who long

Botany. corresponded with Linnæus, and whose countrymen have prepared the sumptuous *Flora Peruviana*; each of the authors of which has repeatedly traversed, at various seasons, the rich and interesting regions, whose botanical treasures make so splendid and novel an appearance in those volumes. Of those treasures, we have still more to learn from the unrivalled Humboldt. The French botanist Aublet, after having gained considerable experience in the Mauritius, resided for many years in Cayenne and Guiana, for the purpose of studying the plants of those countries, of which his work, in four quarto volumes, gives so ample a history and representation.

All the writers just named have been practical botanists. They have generally excelled in specific discrimination, nor have they neglected the study of generic distinctions. Any thing further they have scarcely attempted. It is remarkable that they have all followed, not only the Linnæan principles of definition and nomenclature, but the Linnæan artificial system of classification. This same system was chosen by the veteran Jacquin, in his well-known work on West Indian plants, entitled *Stirpium Americanarum Història*, as well as by Browne in his *History of Jamaica*; not to mention Swartz, in his *Flora Indiæ Occidentalis*, who only wanders a little out of the way, to adopt some of Thunberg's alterations. We cannot but observe, that in the very department of botany in which he has most signalized himself, and with which he is most philosophically conversant, the *Orchideæ*, he totally rejects the ideas of Thunberg.

East Indies. If we now turn our eyes to the oriental world, we shall find that the seeds of Linnæan botany, sown by Koenig, have sprung up and produced successive harvests among the pious missionaries at Tranquebar, who still continue to interweave a sprig of science, from time to time, among their amaranthine wreaths which are not of this world. India too has long possessed a practical botanist of indefatigable exertion and ardour, who has thrown more light upon its vegetable riches, with the important subject of their qualities and uses, than any one since the days of Rheede and Rumphius. It is scarcely necessary to name Dr Roxburgh, whose recent loss we deeply lament, and whose acquisitions and learned remarks are given to the world by the munificence of the East India Company, in a style which no prince has ever rivalled. That enthusiastic admirer of nature, Colonel Hardwicke, and the learned botanist Dr Francis Buchanan, have also contributed greatly to increase our knowledge of Indian botany. The latter has enjoyed the advantage of investigating, for the first time, the remote and singular country of Nepal; so prolific in beautiful and uncommon plants, that few parts of the world can exceed it, and yet meeting, in several points, not only the Floras of the lower regions and islands of India, but those of Japan, China, and even Siberia. The only systematic work on East Indian plants, is the *Flora Indica* of Burmann, which is classed according to the Linnæan artificial method. We cannot but wish it were more worthy of the system or the subject;

Botany. yet, as a first attempt, it deserves our thanks. In speaking of Indian botany, shall we withhold our homage from that great and sublime genius Sir William Jones? who honoured this study with his cultivation, and, like every thing else that he touched, refined, elevated, and elucidated it, with a beam of more than mortal radiance. No man was ever more truly sensible of the charms of this innocent and elegant pursuit; and whenever he adverted to it, all the luminous illustrations of learning, and even the magic graces of poetry, flowed from his pen.

But we must extend our view beyond the utmost bounds of India, and of the then discovered world, to trace the steps of those adventurous circumnavigators who sought out, not only new plants, but new countries, for botanical examination. The names of Banks and Solander have, for nearly half a century, been in every body's mouth. Their taste, their knowledge, their liberality, have diffused a charm and a popularity over all their pursuits; and those who never heard of botany before, have learned to consider it with respect and admiration, as the object to which a man of rank, riches and talents, devotes his life and his fortune; who while he adds, every season, something of novelty and beauty to our gardens, has given the Bread-fruit to the West Indies, and is ever on the watch to prompt, or to further, any scheme of public advantage. With the recollection of such men must also be associated the names of the learned Forsters, father and son, of Sparrmann, and of Menzies, who have all accomplished the same perilous course, and enriched their beloved science. The cryptogamic acquisitions of the latter in New Zealand, prove him to have attended to that branch of botany with extraordinary success, and at the same time evince the riches of that remote country. Indeed, it appears that any country proves rich, under the inspection of a sufficiently careful investigator. The labours of these botanists have all been conducted according to the principles and classification of Linnæus. Forster, under Sparrmann's auspices, has judiciously pointed out, and attempted to remedy, defects that their peculiar opportunities enabled them to discover, but with no invidious aim. They laboured, not to overthrow or undermine a system, which they found on the whole to answer the purpose of readily communicating their discoveries, but to correct and strengthen it for the advantage of those who might come after them. It is much to be lamented that, except the *Nova Genera Plantarum*, we have as yet so short and compendious an account of the acquisitions made in their voyage. To the technical history of these, however, the younger Forster has commendably added whatever he could supply of practical utility, and has thus given us all the information within the compass of his means.

Long since the voyages of these celebrated naturalists, the same remote countries have been visited, in our own days, by two learned botanists more especially; these are M. La Billardiere, and Mr Brown, Librarian of the Linnæan Society. The former has published an account of the Plants of New Holland, in two volumes folio, with fine en-

Botany. gravings; the latter has favoured the botanical world with one volume of a most acute and learned *Prodromus* of his discoveries. As his voyage was made at the public expense, we may trust that the government will consider itself bound to enable him to publish the whole of his acquisitions, in such a manner as to be generally useful. His own accuracy of observation, illustrated by the drawings of the inimitable Bauer, cannot fail to produce such a work as, we will venture to pronounce, has never been equalled. M. La Billardiere has disposed his book according to the system of Linnæus, a rare example in France, where any thing not French usually comes but ill recommended. Mr Brown, on the other hand, has written his *Prodromus*, at least, on the principles of classification established by the celebrated Jussieu, the great champion of a natural system of his own. On this subject we postpone our remarks for the present. Before we can enter on the subject of natural classification, it is necessary to consider the state and progress of botany, for some years past, in the schools, and among the writers, of Europe.

and while in France, he almost planted, or at least greatly advanced, a Linnæan school in that kingdom. He had scarcely resumed his professorial office at home, when he was unexpectedly taken off, by an acute disease, in his forty-second year. Of the talents and performances of his successor Thunberg, who still with honour fills the chair of the Rudbecks and the Linnæi, we have already spoken. Dr Swartz is the Bergian professor of Botany at Stockholm. The *Transactions* of the Upsal Academy, founded by the younger Rudbeck, are continued occasionally; and those of the Stockholm one, whose foundations were laid by Linnæus, are published regularly. Both are from time to time enriched with botanical communications, worthy of the pupils of so illustrious a school. A veteran in botanical science, Professor Retzius, still presides at the University of Lund. The worthy and accurate Afzelius, well known in England, who accomplished a hazardous botanical expedition to Sierra Leone, is the coadjutor of Professor Thunberg; and the difficult subject of Lichens, under the hands of Dr Acharius, is become so vast and so diversified, as to be almost a science of itself.

Botany.

Botanists of Sweden; Sweden has continued to maintain her long established rank in the several departments of natural science, nor has Denmark been behind-hand with her neighbour and ancient rival. The son and successor of the great Linnæus endeavoured to follow his father's steps, and was ambitious of not being left very far in the rear; a commendable aim, which his short life, to say nothing of his talents or experience, disabled him from accomplishing. He completed, and gave to the world, the unfinished materials which his father had left, for a Supplement to his *Species Plantarum* and *Mantissæ*, and having enriched the book with many communications of Thunberg and others, as well as a number of original remarks, he felt a strong desire, not altogether unpardonable, of being thought the principal author of the work. All uncertainty on this subject, wherever other helps fail, is removed by the original manuscript of the *Supplementum Plantarum* in our possession. Ehrhart superintended the printing of this work, and made some alterations in the manuscript, traces of which are perceptible in the affected Greek names, given to some species of *Carex*, *Mespilus*, &c., as well as in their sesquipedalian specific characters. But he had introduced his own new genera of Mosses; which the younger Linnæus thought so alarming an innovation, that he ordered the sheet which contained these matters to be cancelled. We are possessed of a copy, which shows the genera in question to be almost all well founded, and what are now, under Hedwig's sanction, generally received, though by other names. The descriptions of Ehrhart are precise and correct, though his terminology is exceptionable, full of innovations, and crabb'd expressions. Two years, almost immediately preceding the death of the younger Linnæus, were spent by the latter in visiting England, France and Holland, and were employed to very great advantage, in augmenting his collection of natural productions, as well as his scientific skill. During this tour, he attached himself strongly, through the medium of his old friend Solander, to Sir Joseph Banks;

Denmark has always possessed some acute and learned botanists, and has, more than most other countries, been supplied with dried specimens of plants, as an article of commerce, from her West or East Indian establishments. Oeder, the original author of the *Flora Danica*, and Muller its continuator, have distinguished themselves; but their fame is inferior to that of the late Professor Vahl, who studied under the celebrated Linnæus, and who is the author of several excellent descriptive works. He undertook no less than a new *Species*, or, as he entitled it, *Enumeratio Plantarum*, an admirable performance, cut short by his death at the end of the second volume, which finishes the class and order *Triandria Monogynia*. It is almost superfluous to mention, that Afzelius and Retzius, as well as Vahl, in all they have given to the world, have followed the system of their great master. The *Flora Danica*, chiefly a collection of plates, with few synonyms and no descriptions, has come forth, from time to time, for above fifty years past, in fasciculi, without any order, and is still incomplete. It was undertaken by royal command, and, in a great measure, at the sovereign's expense; though regularly sold, except some copies presented to certain distinguished men, as Linnæus.

of Denmark;

After the example of Denmark, Sweden, &c. Russia has been desirous of promoting, throughout its vast dependencies, an attention to natural knowledge. Nor was any country ever more fortunate in the possession of an active and intelligent naturalist. The celebrated Pallas successfully devoted a long life to these pursuits, and to the communication of his discoveries and observations. He prompted the Empress Catharine to offer an unlimited sum for the museum, library, and manuscripts of Linnæus; but, fortunately for their present possessor, the offer was made too late. A *Flora Rossica*, on the most magnificent scale, was undertaken by Pallas, his Imperial mistress proposing to defray the cost of the whole undertaking, not merely for sale, but for gratuitous

Botany.

presentation, on the most princely scale, to all who had any taste or ability to make use of the book. This well-intended munificence was the cause of the ruin of the project. Half of a first volume was bestowed as the Empress intended. But the second part, instead of following the destination of the first, got into the hands of interested people, who defeated the liberal designs of their sovereign, misapplied her money, and by the disgust and disappointment which ensued, prevented the continuance of the work. Those who wished to complete their sets, or to obtain the book at all, were obliged to become clandestine purchasers, buying, as a favour, what they ought to have received as a free gift; and were moreover, like the writer of this, often obliged to put up with imperfect copies. In like manner the intentions of the great Mr Howard, respecting his book on prisons, were rendered ineffectual, by the disgraceful avarice of certain London booksellers, who immediately bought up, and sold at a greatly advanced price, the whole edition, which its benevolent author had destined to be accessible to every body at an unusually cheap rate. These examples, amongst others, show that it is the most difficult thing in the world to employ patronage, as well as gratuitous charity of any kind, to real advantage, except under the guidance of the most rigorous discretion. "All that men of power can do for men of genius," says Gray, if we recollect aright, "is to leave them at liberty, or they become like birds in a cage," whose song is no longer that of nature and enjoyment. The great and the affluent may foster and encourage science and literature, by their countenance, their attention, and a free, not overwhelming, liberality. But when princes become publishers of books, or directors of academies, they generally do more harm than good. They descend from their station, and lose sight perhaps of their higher and peculiar duties, which consist in promoting the general prosperity, peace, and liberty of their subjects, under the benign influence of which, every art, science, or pursuit, that can be beneficial to mankind, is sure to flourish without much gratuitous assistance.

of Germa-
ny;

Several of the immediate scholars of the illustrious Swedish naturalist were planted in different parts of Germany. Murray, to whom he entrusted the publication of that compendious volume, entitled, *Systema Vegetabilium*, and who printed two successive editions of the work, was seated as Professor at Gottingen. Giseke was established at Hamburgh, and, after the death of Linnæus, gave to the world such an edition as he was able to compile, from his own notes and those of Fabricius, of the lectures of their late preceptor, on the Natural Orders of Plants. His ideas on this subject Linnæus himself always considered as too imperfect to be published, except in the form of a sketch or index, at the end of his *Genera Plantarum*. The venerable patriarch, Professor Jacquin, still survives at Vienna, where he, and his worthy son, have enriched botany with a number of splendid and useful works. They have given to the public several labours of the excellent practical botanist Wulfen, and others, which might, but for their encouragement, have been lost. The highly valua-

Botany.

ble publication of Host on grasses, is conducted on the plan of Jacquin's works. His *Synopsis* of Austrian plants is an excellent *Flora*, disposed according to the Sexual System, as is the more ample *Tentamen Floræ Germanicæ* of the celebrated Dr Roth, one of the best practical European botanists, and more deeply versed than most others in cryptogamic lore. The best Linnæan *Flora*, as far as it goes, that the world has yet seen, we speak it without any exception, is the *Flora Germanica* of Professor Schrader of Gottingen, the first volume of which, comprising the first three classes of the sexual system, was published in 1806. The correct distinctions, well-digested synonyms, and complete descriptions of this work, are altogether unrivalled. If the whole should be equally well executed, for which the longest life would be scarcely sufficient, it must ever be the standard book of European botany. Its descriptions of grasses are worthy to accompany the exquisite engravings of the same tribe from the hand of Leers, published at Herborn in 1775, which excel every other botanical representation that we have examined. They will bear, and indeed they require, the application of a magnifying-glass, like the plants themselves. The purchaser of this little volume must however beware of the second edition, whose plates are good for little or nothing. The name of Schrader has long been distinguished in Cryptogamic Botany. In this pursuit, the industrious and accurate botanists of Germany, shut out from extensive opportunities of studying exotic plants, have had full scope for their zeal and abilities. In this field the Leipsic school has distinguished itself. Here the great Schreber first began his career with some of the most perfect cryptogamic works, especially on the minute genus *Phascum*. Here the same author published his excellent *Flora Lipsiensis*, his laborious practical work on Grasses, and finally his improved edition of the *Genera Plantarum* of his friend Linnæus. But, above all, Leipsic is famous for being the residence of Hedwig, whose discoveries, relative to the fructification and generic characters of Mosses, form an era in botanic science. Under the hands of such an observer, that elegant tribe displays itself with a degree of beauty, variety and singularity, which vies with the most admired herbs and flowers, and confirms the Linnæan doctrine of impregnation, which the more obvious organs of the latter had originally taught. Nor must we, in speaking of cryptogamic plants, neglect here to record the names of Weis, Weber, Mohr, Schmidel, Esper, and especially Hoffmann; the plates of the latter, illustrating the Lichen tribe, are models of beauty and correctness. His *Flora Germanica* is a most convenient and compendious manual, after the Linnæan system. *Fungi* have been studied in Germany with peculiar care and minuteness. The leading systematic author in this obscure tribe, Persoon, was indeed born, of Dutch parents, at the Cape of Good Hope; but he studied and published at Gottingen. Two writers, of the name of Albertini and Schweiniz, have published the most minute and accurate exemplification of this natural order, in an octavo volume, at Leipsic, in the year 1805, comprising the *Fungi* of the district of Niaki in Upper Lusatia. If their fi-

gures are less exquisitely finished than Persoon's, or less elaborately detailed than Schrader's, their descriptions make ample amends.

The German school of botany has, for a long period, been almost completely Linnæan. This however was not always the case, for, in the earlier part of his career, the learned Swede was attacked more repeatedly and severely from this quarter of the world than any other; his ridiculous critic Siegesbeck of Petersburg excepted, who would not admit the doctrine of the sexes of plants, because the pollen of one flower may fly upon another, and his purity could not bear the idea of such adultery in Nature. Numerous methods of arrangement appeared in Germany, from the pens of Heister, Ludwig, Haller, and others, and even Schreber adopted a system like some of these in his *Flora* above mentioned. It would be to no purpose now to criticise these attempts. They cannot rank as natural systems, nor have they the convenience of artificial ones. Part of their principles are derived from Linnæus, others from Rivinus. Their authors were not extensively conversant with plants, nor trained in any sound principles of generic discrimination or combination. They set off with alacrity, but were soon entangled in their own difficulties, and were left by Linnæus to answer themselves or each other. We here mention these learned systematics, for learned they were thought by themselves and their pupils, merely because they will scarcely require animadversion, when we come to canvass the great question of natural and artificial classification, they having had no distinct ideas of a difference between the two. Hedwig used frequently to lament, that his preceptor Ludwig had never perfected his system of arrangement; but from what he has given to the world, we see no great room to suppose he had any thing very excellent in reserve. Unexecuted projects are magnified in the mists of uncertainty. We have ventured elsewhere, in a biographical account of Hedwig, to remark, that even that ingenious man "did not imbibe under Ludwig, anything of the true philosophical principles of arrangement, the talents for which are granted to very few, and are scarcely ever of German growth. We mean no invidious reflections on any nation or people. Each has its appropriate merits, and all are useful together in science, like different characters on the theatre of human life."

Germany may well dispense with any laurels obtained by the very secondary merit of speculative schemes of classification, when she can claim the honour of having produced such a practical observer as Gærtner. This indefatigable botanist devoted himself to the investigation of the fruits and seeds of plants. Being eminently skilled in the use of the pencil, he has, like Hedwig, faithfully recorded, what he no less acutely detected. The path he struck out for himself, of delineating and describing in detail, with magnified dissections, every part of the seed and seed-vessel of each genus within his reach, had never been explored before in so regular and methodical a manner. Botanists of the Linnæan school are justly censurable for having paid too little attention to the structure of these important parts,

in their generic characters. Indeed it may be said, that if they were able to establish good genera without them, and, after the example of their leader, merely preferred the more obvious and distinct organs, when sufficient for their purpose, their conduct was justifiable. If generic principles be natural and certain, it matters not on what parts of the fructification they are founded; nor is the inflorescence, or even the herb or root, rejected by sound philosophers, but because they are found to lead only to unnatural and uncertain characters. It is therefore extremely to the honour of Linnæus, Gærtner and Jussieu, that their conceptions of genera are almost entirely the same. They meet in almost every point, however different the paths by which they pursue their inquiries. Their labours illustrate and confirm each other. Even Tournefort, who conceived so well, on the whole, the distinctions of genera, which he could but ill define, receives new strength from their knowledge, which does not overturn his imperfect performances, but improve them. The accurate student of natural genera cannot fail to perceive, that where Gærtner differs from Linnæus, which is but in a very few material instances, such as his numerous subdivision of the genus *Fumaria*, and his distribution of the compound flowers, it arises from his too intent and exclusive consideration of one part of the fructification, instead of an enlarged and comprehensive view of the whole. In other words, he neglects the Linnæan maxim, that "the genus should give the character, not the character the genus." Such at least appears to us the case in *Fumaria*. In the syngenesious family, being so very natural in itself, the discrimination of natural genera becomes in consequence so difficult, that Gærtner and Linnæus may well be excused if they do not entirely agree, and they perhaps may both be satisfied with the honour of having collected materials, and disposed them in different points of view, for the use of some future systematic, who may decide between them. However exact Gærtner may have been in discriminating the parts of seeds, we believe him mistaken in distinguishing the *visellus* as a separate organ, distinct in functions from the *cotyledons*. His readers will also do well, while they profit by his generally excellent principles, not to admit any of his rules as absolute. They may serve as a clue to the intricacies of Nature, but they must not overrule her laws. Still less is our great carpologist to be implicitly followed in physiological doctrines or reasonings; witness his feeble and incorrect attack on Hedwig's opinions, or rather demonstrations, respecting the impregnation of Mosses. His criticisms of Linnæus are not always marked with that candour which becomes a disinterested lover of truth and nature, nor can we applaud in general his changes of nomenclature, or of terminology; especially when he unphilosophically calls the *germen* of Linnæus, the *ovarium*, a word long ago rejected, as erroneous when applied to plants. These however are slight blemishes, in a reputation which will last as long as scientific botany is cultivated at all. Botanists can now no longer neglect, but at their own peril, the parts which Gærtner has called into notice, and to the scrutiny of which, directed by his faithful guid-

Botany.
of Prussia;

ance, the physiologist and the systematic must often, in future, recur.

We shall close this part of our subject with the mention of the Berlin school, where Gleditsch, who, in 1740, repelled the attacks of Siegesbeck on Linnæus, was Professor, and published a botanical system, founded on the situation, or insertion, of the stamens; the subordinate divisions being taken from the number of the same parts; so that it is, in the latter respect, a sort of inversion of the Linnæan method. In the former, or the outline of its plan, the system of Gleditsch is in some measure an anticipation of that of Jussieu. Berlin has of late been much distinguished for the study of natural history, and possesses a society of its own, devoted to that pursuit. Its greatest ornament was the late Professor Willdenow, who if he fell under the lash of the more accurate Afzelius, is entitled to the gratitude of his fellow-labourers, not for theoretical speculations, but for the useful and arduous undertaking of a *Species Plantarum*, on the Linnæan plan, being indeed an edition of the same work of Linnæus, enriched with recent discoveries. This book, left unfinished at the end of the first order of the *Cryptogamia*, by the death of the editor, wants only a general index to render it sufficiently complete. The *Musci*, *Lichenes*, and *Fungi*, are systematically treated in the separate works of writers devoted to those particular, and now very extensive, subjects, from whom Willdenow could but have been a compiler. With the *Filices*, which he lived to publish, he was practically conversant. His insertion of the essential generic characters, throughout these volumes, is an useful addition, and now become necessary in every similar undertaking.

of Holland; Little can be said of Holland in this review of the botanical state of Europe for a few years past. The Leyden garden has always been kept up, especially during the life of the late Professor David Van Royen, with due care and attention; we know little of its fate in the subsequent convulsed state of the country. Botany has long been on the decline at Amsterdam, though we are indebted to that garden for having first received, and afterwards communicated to other countries, such acquisitions of Thunberg in Japan as escaped the perils of importation.

of Switzerland;

The botany of Switzerland may, most commodiously, be considered in the next place. Here, in his native country, the great Haller, after a long residence at Gottingen, was finally established. Its rich and charming *Flora* has been illustrated by his classical pen, with peculiar success. Every body is conversant with the second edition of his work, published in 1768, in 3 vols. folio, and entitled, *Historia Stirpium Indigenarum Helvetiæ*, with its inimitable engravings, of the *Orchis* tribe more particularly. But few persons, who have not laboured with some attention at the botany of Switzerland, are aware of the superior value, in point of accuracy, of the original edition of the same work, published in 1742; under the title of *Enumeratio Methodica Stirpium Helvetiæ Indigenarum*. This edition is indispensable to those who wish fully to understand the subject, or to appreciate Haller's transcendent knowledge and abilities. These works are classed after a system of his

Botany.

own, intended to be more consonant with nature than the Linnæan sexual method. We can scarcely say that it is so, on the whole; nor is it, on the other hand, constructed according to any uniformity of plan. The number of the stamens, compared with that of the segments of the corolla, or its petals, regulate the characters of several classes, and those are artificial. Others are assumed as natural, and are for the most part really so, but their characters are frequently taken from Linnæus, even from his artificial system, as the *Cruciatae*, and the *Apetala*. Lord Bute has well said, that Haller was a Linnæan in disguise. His classification however merely intended to answer his own purpose, with respect to the Swiss plants; for he was not a general botanist, nor had he a sufficiently comprehensive view of the subject to form a general system, or even to be aware of the difficulties of such an undertaking. He ought not therefore to be obnoxious to criticism in that view. His method has served for the use of his scholars, as the Linnæan one serves English botanists, by way of a dictionary. Some such is necessary; and those who should begin to decide on the merits of a system, before they know plants, would most assuredly be in danger of appearing more learned to themselves than to others. We cannot exculpate Haller from some degree of prejudice in rejecting real improvements of Linnæus, which are independant of classification; such as his trivial or specific names, by which every species is spoken of at once, in one word, mostly so contrived as to assist the memory, by an indication of the character, appearance, history, or use, of the plant. What did the great Swiss botanist substitute in the place of this contrivance? A series of numbers, burthensome to the memory, destitute of information, accommodated to his own book only, and necessarily liable to total change on the introduction of every new-discovered species! At the same time that he rejected the luminous nomenclature of his old friend and fellow-student, who had laboured in the most ingenious terms to deprecate his jealousy, he paid a tacit homage to its merit, by contending that the honour of this invention was due to Rivinus. In this he was not less incorrect than uncandid, the short names of Rivinus being designed as specific characters, for which purpose Haller knew, as well as Linnæus, they were unfit. Useful specific characters he himself constructed on the plan of Linnæus, with some little variation, not always perhaps for the better, as to strictness of principle, but often strikingly expressive. Here, as in every thing connected with practical botany, he shines. The most rigid Linnæan, whose soul is not entirely shrivelled up with dry aphorisms and prejudices, must love Haller for his taste and enthusiasm, and the *Flora* of Switzerland as much for his sake as its own. No wonder that his pupils multiplied, and formed a band of enthusiasts, tenacious of even the imperfections of their master. The line of demarcation is now no longer distinctly drawn between them and the equally zealous scholars of the northern sage. The amiable and lamented Davall strove to profit by the labours of both. The Alpine botanists of France and Italy have served to amalgamate the Swedish and

Botany. the Helvetian schools. The Flora of Dauphiny by Villars is nearly Linnæan in system, and the principles of the veteran Bellardi of Turin are entirely so; though he has been, in some of his publications, obliged to conform to the method of his late preceptor, the venerable Allioni, who in spite of all remonstrance, had the ambition of forming a system of his own. His *Flora Pedemontana* is disposed according to this system, an unnatural and inconvenient jumble of the ideas of Rivinus, Tournefort, and others. This work is also faulty in the neglect of specific definitions, so that its plates and occasional descriptions are alone what render it useful; nor would it perhaps, but for the uncommon abundance of rare species, be consulted at all.

of Italy We may glance over the botany of Italy, to whose boundaries we have thus been insensibly led, as the eye of the traveller takes a bird's-eye view of its outstretched plains from the summits of the Alps. We may pass from Turin to Naples without meeting with any school of distinction. The northern states are not without their professors and patrons of botany, nor are their nobles destitute of taste, in various branches of natural knowledge. The names of a Castiglione of Milan, a Durazzo and Dinegro of Genoa, and a Savi of Pisa, deserve to be mentioned with honour, for their knowledge and their zeal. The unfortunate Cyrillo, and his friend Pacifico, at Naples, were practical botanists. There is also a rising school, of great promise, at Palermo. But since the time of Scopoli, Italy has contributed little to our stock of information; nor are the latter publications of this eminent man, while he resided at Pavia, commensurate in importance or merit with those earlier ones, the *Flora*, and *Entomologia Carniolica*, which have immortalized his name. Scopoli, who at first adopted a system of his own, had the sense and liberality, in his second edition, to resign it, in favour of what his maturer experience taught him to prefer, the sexual system of Linnæus.

of Spain and Portugal. Spain and Portugal claim our attention; the former for being the channel through which the gardens of Europe have been, for some years past enriched with many new Mexican and Peruvian plants; and likewise as the theatre of the publication of some important books, relative to the botany of those countries. In speaking of American botany, we have mentioned the *Flora Peruviana*, whose authors, Ruiz and Pavon, rank deservedly high for their industry and knowledge. The late Cavanilles, resident at Madrid, has also communicated to the learned world much information, from the same source. Spain seems anxious to redeem her reputation, which suffered so much from the neglect, or rather persecution, of the truly excellent but unfortunate Dombey, who, like many other benefactors of mankind, was allowed to make all his exertions in vain, and finally perished unknown, in the diabolical hands of English slave-dealers at Montserrat. Portugal is most distinguished at home by the labours of a learned benedictine, Dr Felix Avellar Brotero, author of a *Flora Lusitanica*, disposed after the Linnæan method, reduced entirely to principles of number; and abroad by the valuable work of Father Loureiro, entitled *Flora Cochinchinensis*, in which the plants

Botany. of Cochinchina, and of the neighbourhood of Canton, are classed and defined in the Linnæan manner, with valuable descriptions and remarks. It is undoubtedly a disgrace to the possessors of such a country as Brasil, that they have not derived from thence more benefit to the world, or to themselves, from its natural productions. But they are satisfied with what the bowels of the earth afford, and they neglect its more accessible, though perhaps not less valuable, treasures. The jealousy, and innumerable restrictions of their government, render what they possess as useless to all the world as to themselves. A genius of the first rank in natural science, as well as in every thing which his capacious mind embraced, has arisen in Portugal, and has been domesticated in the schools of Paris and London, the amiable and learned Correa de Serra, now a traveller in the United States of America. What little impulse has been given to literature in Portugal, and particularly the foundation of a Royal Academy of Sciences, is owing to him; and though his name has chiefly appeared in the ranks of botanical science in an incidental manner, no one possesses more enlarged and accurate views, or more profound knowledge, of the subject.

In the extensive, though incomplete, review which English and we have undertaken of the recent history of botanical science, the individual merits of particular writers have chiefly hitherto been detailed and compared. The most difficult part of our task perhaps still remains; to contrast and to appreciate the influence and the merits of two great and rival nations, in the general school of scientific botany; to consider the causes that have led to the particular line which each has taken, and to compare the success, as well as to calculate the probable future consequences of their respective aims. England and France have, from the time of Ray and Tournefort, been competitors in botanical fame, because each was ambitious of supporting the credit of the great man she had produced. This contest, however, as far as it regarded theoretical speculations, has entirely subsided on the part of Ray's champions. In practical science, likewise, the admirers of Ray and of Tournefort have shaken hands, like those of every other school. On the subject of system, the question is greatly changed; for though a phoenix has arisen from the ashes of Tournefort, its "star-like eyes," darting far beyond all former competition, have been met, if not dazzled, by a new light, rising in full glory from the north; a polar star, which has been hailed by all the nations of the earth.

The Linnæan system of classification, with all its **English.** concomitant advantages of nomenclature, luminous technical definition, and richness of information, was planted, like a fresh and vigorous acyon, in the favourable soil of England, already fertilized with accumulations of practical knowledge, about the middle of the last century. If we may pursue the metaphor, the ground was entirely cleared for its reception; for all previous systems had been of confined and local use; the alphabetical index having become the resource of even the most learned; and the pupils of Ray, being held to his method of classification,

Botany.

rather by their gratitude for his practical instruction, than any other consideration. Accordingly we have, in our own early progress, before they were all, as at present, swept off the stage, found them rather contending for his nomenclature, imperfect as it was, because they were habituated to it, than for his system, of which, it was evident, they had made little use. Hence the first attempt in England, to reduce our plants to Linnæan order, made by Hill, was chiefly a transposition of Ray's *Synopsis* into the Linnæan classes, the original nomenclature being retained, while the specific names of the *Species Plantarum* were rejected.

Norwich.

Hill's imperfect performance was superseded, by the more classical *Flora Anglica* of Hudson, composed under the auspices and advice of the learned and ingenious Stillingfleet, in which the botany of England assumed a most scientific aspect, and with which all the knowledge of Ray was incorporated. At the same time, the principles of theoretical botany, and the philosophical writings of the learned Swede, were studied with no ordinary powers of discrimination and judgment, in a small circle of experienced observers at Norwich. A love of flowers, and a great degree of skill in their cultivation, had been long ago imported into that ancient commercial city, with its worsted manufacture, from Flanders; and out of this taste, something like the study of systematic botany had sprung. These pursuits were mostly confined to the humblest of the community, particularly among the then very numerous bodies of journeyman weavers, dyers, &c. Towards the middle of the eighteenth century, several of the opulent merchants seem to have acquired, by their intimate connection with Holland, not only the above-mentioned taste for horticulture, but likewise an ambition to be distinguished by their museums of natural curiosities. The former sometimes extended itself, from the flowery parterre, and the well-arranged rows of tulips, hyacinths, carnations, and auriculas, into no less formal labyrinths, or perhaps a double pattern of angular or spiral walks, between clipped hedges, exactly alike on each side of a broad gravel walk. Such was the most sublime effort of the art within the compass of our recollection. "Grove" could by no means be said to "nod at grove," for the perpendicular and well-trimmed structure was incapable of nodding; but that "each alley should have a brother" was an indispensable part of the design. Greenhouses of exotic plants, except oranges and myrtles, were at this time scarcely known; and the writer well recollects having seen, with wonder and admiration, above forty years ago, one of the first African Geraniums that ever bloomed in Norwich. If, however, the progress of natural science was slow in this angle of the kingdom, the wealthy manufacturers, become their own merchants, found it necessary to acquire a knowledge of various foreign languages, in order to carry on their wide-extended commerce. In learning French, Italian, Spanish, Dutch, and German, they unavoidably acquired many new ideas. Their sons were sent to the continent, and it were hard, indeed, if many of them did not bring home much that was worth learning. The society of the place,

aided by some concomitant circumstances, and the adventitious acquisition of two or three men of singular talents and accomplishments, became improved. A happy mixture of literature and taste, for many years distinguished this city, above its rivals in opulence and commercial prosperity. Such Norwich has been in our memory, and if its splendour be gone by, a taste for mental cultivation, originating in many of the before-mentioned causes, still remains, and is fostered by the novel pursuits of chemistry and natural history, on which some arts, of great importance in the manufactory of the place, depend for improvement. We trust the reader will pardon this digression from the subject more immediately before us, to which we shall now return.

Some of the more learned students of English plants, among the lovers of botany in Norwich, had long been conversant with the works of Ray, and even the *Historia Muscorum* of Dillenius. They were prepared therefore to admire, and to profit by, the philosophical writings of Linæus. Hence originated the *Elements of Botany*, published in 1776, by Mr Hugh Rose; who was aided in the undertaking by his equally learned friend, the Reverend Henry Bryant, of whose acuteness and botanical skill no better proof is wanting, than his having found and determined, nine years before, the minute *Tillæa muscosa*, for the first time in this island. Numerous pupils were eager to improve themselves by the assistance of such masters, and amongst others the writer of these pages imbibed, from their ardour and their friendly assistance, the first rudiments of a pursuit that has proved the happiness and the principal object of his life.

London became, of course, the focus of this science, as well as of every other. Of the English Universities, Cambridge most fulfilled its duty, in rendering its public establishments useful to the ends for which they were founded and paid. The names of Martyn, both father and son, have long maintained a distinguished rank in botany, and the latter, for many years, has inculcated the true principles of Linnæan science, from the professor's chair. A botanic garden was established, by a private individual, Dr Walker, about the period of which we are speaking. A Linnæan *Flora Cantabrigiæ*, by Mr Rehan, has renewed the celebrity of that field, in which Ray had formerly laboured; and there has always existed a little community of Cambridge botanists, though fluctuating and varying, according to circumstances. At Oxford, botany, so vigorously established by Sherard and Dillenius, slept for forty years under the auspices of the elder Professor Sibthorp, at least as to the utility of its public foundations. Yet even there the science had many individual cultivators, and if others were forgotten, the name of a Banks ought to render this school for ever celebrated. The younger Professor Sibthorp well atoned for the supineness of his father and predecessor. He published a *Flora Osoniæ*, and extended his inquiries into the classical scenes of Greece, finally sacrificing his life to his labours, and sealing his love of this engaging study by a posthumous foundation, which provides for the publication of a sumptuous *Flora Græca*, and the subsequent ac-

Botany.

London, Cambridge, and Oxford.

Botany. establishment of a professorship of Rural Economy. Edinburgh, under the auspices of the late worthy Professor Hope, became distinguished for the cultivation of botany; as a branch of medical education. The physiology of plants was there taught, more assiduously than in almost any other university of Europe; and the Linnæan principles were ably enforced and illustrated, not with slavish devotion, but with enlightened discrimination. Nor must the dissenting Academy at Warrington be forgotten, where the distinguished circumnavigator Forster, of whom we have already spoken, was settled. Here many young naturalists were trained. The neighbouring family of the Blackburnes, possessed even to this day, of one of the oldest and richest botanic gardens in England, have steadily fostered this and other branches of natural knowledge. The same taste has spread to Manchester, Liverpool, and the country around. Westmoreland, Northumberland and Durham have their sequestered practical botanists, in every rank of life. Scenes celebrated by the correspondents of Ray are still the favourite haunts of these lovers of nature and science, who every day add something to our information, and to the celebrity of other parts of the same neighbourhood.

London
School.

We must now concentrate our attention to the London school, which, for about forty years past has maintained a rank superior to most other seats of botanical science; the more so perhaps for its being founded in total disinterestedness, both with respect to authority and emolument. Truth alone, not system, has been the leading object of this school; unbiassed and gratuitous patronage its support; and a genuine love of nature and of knowledge its bond of union, among persons not less distinguished from each other by character and opinion, than by their different pursuits, and various ranks of life. The illustrious Banks, from the time when, after his return from his celebrated and adventurous voyage, he devoted himself to the practical cultivation of natural science for the advantage of others, as he had long pursued it for his own pleasure and instruction, has been the head of this school. Here he fixed the amiable and learned Solander, for the remainder of his too short life. The house of this liberal Mæænas has ever since been, not only open, but, in a manner, at the entire command of the cultivators and admirers of this and other branches of philosophy; inasmuch as his library and museum have been devoted to their free use; and his own assistance, encouragement and information are as much at their service, as if his fortune and fame had all along depended on their favour. With such an establishment as this, aided by the perpetual resources of the numerous public and private gardens around, botany might well flourish. The liberal spirit of the leaders of this pursuit, gave a tone to the whole. The owners of nurseries, though depending on pecuniary emolument for their support, rivalled each other in disinterested communication. The improvement of science was the leading object of all. One of this latter description took his rank among the literary teachers of botany. Lee's *Introduction* was much approved by Linnæus, whose system and principles it ably exemplifies, and who became the friend and correspondent of its

author. Travelling botanists were dispatched, under the patronage of the affluent, to enrich our gardens from the Alps, the Cape of Good Hope, and the various parts of America. Every new acquisition was scrutinized, and received its allotted name and distinction, from the hand of the correct and classical Solander, who one day was admiring with Collinson, Fothergill, or Pitcairn, the treasures of their respective gardens, and another labouring with the distinguished Ellis, at the more abstruse determination of the intricate family of marine productions, whether sea-weeds, corallines or shells. His own acquisitions, and those of his friend and patron, in the fairy land of the South-Sea Islands, the hazardous shores of New Holland, or the nearly fatal groves and swamps of Java, were at the same time recorded by his pen, as they were gradually perpetuating by the slow labours of the engraver. To this band of zealous naturalists the younger Linnæus was, for a while, associated, as well as the excellent and zealous Broussonet, who though not unversed in botany, devoted himself most particularly to the more uncommon pursuit of scientific ichthyology.

The Banksian school, altogether intent upon practical botany, had adopted the Linnæan system as the most commodious, while it pursued and cultivated the Linnæan principles, as the only ones which, by their transcendent excellence, could support the science of botany on a stable foundation. In these Dr Solander was, of course, well trained; and, having added so wide a range of experience to his theoretical education, few botanists could vie with him, who had, as it were, caught his preceptor's mantle, and imbibed, by a sort of inspiration, a peculiar talent for concise and clear definition. Abstract principles of classification, or even such outlines of natural arrangement as Linnæus had promulgated, seem never to have attracted Solander. In following the chain of his ideas, discernible in the materials he has left behind him, one cannot but remark his singular inattention to every thing like botanical affinity, to which the artificial sexual system was, with him, entirely paramount. The genera which, for extemporaneous use, he named with the termination *oides*, comparing each with some well-known genus, till a proper appellation could be selected, are seldom thus compared because of any natural affinity, nor scarcely any external resemblance, but because they agree with such in their place in the artificial system, or nearly perhaps in technical characters. A great botanist therefore, it is evident, may exist, without that vaunted erudition in a peculiar line, which some would have us consider as the only road to knowledge and to fame. We allow that this sort of erudition is now, since the attention it has received from Linnæus, Jussieu, and others, become indispensable to a good theoretical or philosophical botanist, as is the study of carpology, in consequence of the labours of Gærtner; we only contend that it is possible to know plants extremely well without either.

The learned Dryander, less skilled than his predecessor as the coadjutor of Sir Joseph Banks, in a practical acquaintance with plants, exceeded him in theoretical lore and ingenious speculation, and far excelled every other man in bibliographic informa-

Botany.

Botany.

tion, as well as in the most precise fastidious exactness relative to every subject within the wide extent of his various knowledge. He furthered, upon principle, and with unwearied assiduity, every object of the noble establishment to which he was devoted; but he, like Solander, now sleeps with his fathers, and his place is supplied by a genius of British growth, who unites talents with experience, and theoretical skill, in the most eminent degree, with practical knowledge.

Although it is almost superfluous to name the most eminent disciples of the London school of botany, it might seem negligent to pass them over without some particular mention. The ardent and ingenious Curtis has left a permanent monument behind him, in the *Flora Londinensis*, to say nothing of the popular *Botanical Magazine*, continued by his friend Dr Sims. The *Flora Scotica* of Lightfoot first offered, in a pleasing and familiar garb, the botanical riches of that part of the island to its southern inhabitants. The lynx-eyed Dickson, so long and faithfully attached to his constant patron, has steadily traced, through all its windings, the obscure path of cryptogamic botany, with peculiar success. No more striking instance can be pointed out, to prove how totally the most consummate practical skill, even in the most difficult part of botany, is independent of theoretical learning. Even those who profit by the certain aids supplied by the discoveries of Hedwig, can with difficulty keep pace with this veteran in their pursuits, who, with conscious independence, neglects all those aids.

Museum and Library of Linnæus.

Just at the time when the school, whose history we are endeavouring to trace, had most firmly established its credit and its utility, a great additional weight was given to England, in the scale of natural science, by the acquisition of the entire museum, library and manuscripts of the great Linnæus and his son, which came amongst us, by private purchase, in 1784, after the death of the latter. Hence our nomenclature has been corrected, and our knowledge greatly augmented. These collections have necessarily been consulted by most persons, about to publish on the subject of natural history, and a reference to them, in doubtful cases, secures a general conformity of sentiment and nomenclature, among the botanists of Europe, Asia and America. We are seldom obliged to waste time in conjecturing what Linnæus, or the botanists with whom he corresponded, meant, for we have before us their original specimens, named by their own hands. An entire London winter was devoted to the almost daily labour, of comparing the Banksian herbarium throughout, with that of Linnæus, and to a copious interchange of specimens between their respective possessors, who, with the aid of Mr Dryander alone, accomplished this interesting and instructive comparison. Hence the *Hortus Kewensis* of the lamented Aiton, which was at that period preparing for publication, became much more correct in its names, than it, or any other similar performance, could have been, without this advantage. It could scarcely be imagined that Sweden would, unmoved, thus let the botanical sceptre pass from her; but it is much to the honour of the nation, that all her naturalists have ever preserved the most friendly intercourse with us,

particularly with the person who deprived them of this treasure. They have not merely pardoned, but publicly sanctioned, the scientific zeal which prompted him to this acquisition, by associating him with all their learned establishments, without any solicitation on his part.

The institution of the Linnæan Society at London in 1788, especially under that name, must be considered as a triumph for Sweden in her turn. By this establishment the intercourse of science is facilitated; essays, which might otherwise have never seen the light, are given to the world; and a general taste for the pleasing study of nature is promoted. Learned and worthy people are thus made acquainted with each other, from the remotest corners of the kingdom, and their information enriches the common stock. The state has given its sanction to this rising establishment. Its publications and its members are spread over the Continent, and other similar institutions have borrowed its name, imitated its plan, and paid respect to its authority. Yet it is not in the name alone of Linnæus, that the members of this society place their confidence; still less do they bow to that name or to any other, at the expense of their own right of private judgment. Their Transactions are open to the pupils of every school, and the observations of every critic, that have any prospect of being useful to the world. The writer of each communication, must, of course, be answerable for the particulars of his own performance, but the Society is responsible for each being, on the whole, worthy to be communicated to the public. The possession of the very materials with which Linnæus worked, his own specimens and notes, enable us very often to correct mistakes, even of that great man, many of which would be unaccountable without the means of thus tracing each to its source. At the same time, the acquisition of materials to which he never had access, tends to improve and augment the history of what he had left imperfect. His language, his definitions and characters were, for some time, held so sacred, that they were implicitly copied, even though manifestly inapplicable, in some points, to the objects to which they were referred. Synonyms were transcribed from his works by Rose, Hudson, Curtis, and even Gærtner, (we assert it on the positive proof of errors of the press, copied in the transcribing), without reference to the original books, to see whether such synonyms, or their accompanying plates, agreed with the plant under consideration. The example of Dr Solander first led the writer of this to avoid such a negligent and unfaithful mode of proceeding; yet he has ever considered as sacred the very words of Linnæus, where they require no correction. They are become a kind of public property, the current coin of the botanical realm, which ought not, with impunity, to be falsified or adulterated. To them we hope to be pardoned if we apply the words of the poet,

“ The solid bullion of one sterling line,
Drawn to French wire, would through whole pages shine.”

Of this it is needless to quote examples. We must be every day more and more sensible of the value of

Botany. the Linnæan style, in proportion as the number of those who can attain it is evidently so very small. By the light of our master alone can the science, which he so greatly advanced and refined, be preserved from barbarism, while long and tedious, loose and feeble, ill-contrasted and barbarously-worded definitions, press upon it from various quarters. New terms are invented to express old ideas; names and characters are changed for the worse, to conceal the want of new discoveries; and students are often deterred from adopting real improvements, because they know not which guide to prefer.

Practical Study of Botany in England.

From the combined effects of the various causes which we have endeavoured to trace, the study of botany in England has, for a long period, been almost entirely practical. To determine the particular species intended, in every case, by Linnæus; to distinguish and to describe new ones; to improve scientific characters, and to correct synonyms; these have been the objects of our writers; and hence many publications of great utility, especially a number of critical and descriptive essays, in the Transactions of the Linnæan Society, not unworthy of the school which gave them birth, have enriched the general stock of knowledge. These are the sound fruits of skill and investigation, the solid-advantages of real information, applied to practical use. They are independent of theoretical speculation, and will stand unshaken, amidst any possible changes of system. On such principles the *Flora Britannica* has been attempted, and continued as far as the present unsettled state of some of the latter orders, of the last class, will allow. Such impediments, which depend on the difficulties of systematic discrimination, among the Lichens especially, it is hoped will soon be removed. Meanwhile the *English Botany* of the same writer, illustrated by Mr Sowerby's expressive and scientific figures, has finished its course, and formed so nearly complete a body of local botany, as, we believe, no other country has produced. In this the liberal contributions of numerous skillful observers, from the Alpine heights of Scotland to the shores and circumambient ocean of the south, are preserved and recorded; evincing a degree of general inquiry and acuteness, which hardly any nation can rival. The memory of several benefactors to the science, otherwise in danger of passing away, is embalmed in this national work, which serves at once as their botanical testament, and the monument of their fame. Some of our botanists of the present day have thrown great light on several of the most obscure departments of the science; witness Mr Sowerby's work on *English Fungi*; the labours of the learned Bishop of Carlisle on *Carices*, and, in conjunction with Mr Woodward, on *Fuci*; of Mr Dawson Turner on the latter tribe, and on the *Musci* of Ireland; but especially Mr Hooker's inimitable display of the British *Jungermannia*. Nor shall the contributions of a Winch or an Abbot, a Withering, Knapp, Stackhouse or Vellej, nor the more splendid labours of the indefatigable Lambert, be forgotten. Each, in one way or other, has enlarged the bounds of science, or rendered it easier of access. We cannot, in the compass of our present undertaking, pay the tribute due to every individual, our aim

being a general picture of the whole. From what we have said, the zeal with which this lovely science has been cultivated in England, will sufficiently appear. Nor have public lectures, or botanic gardens, been neglected, in order to render the knowledge of botany as accessible as possible, and to diffuse a taste for its pursuit. The popularity of the study has, at least, kept pace with the means of instruction. The garden and green-house, the woods, fields, and even the concealed treasures of the waters, are now the resource of the young and the elegant, who in the enjoyment of a new sense, as it were, in the retirement of the country, imbibe health, as well as knowledge and taste, at the purest of all sources.

Botany.

France alone now remains to be considered, in order to finish the historical picture which we have undertaken, of the state of botanical science in Europe. To do justice to this part of our subject, we must turn our attention to times long since gone by, or we shall scarcely render intelligible the state of affairs at present.

The great Tournefort, by the force of his character, his general and particular information, the charms of his pen, and the celebrity which his name gave to his country, through the popularity of his botanical system, was so firmly established, in the ideas of the French, as the *Grand Monarque* of botany, that they would have as soon allowed the greatness of Louis XIV. to be questioned, as that of this distinguished philosopher. So beneficial was this partiality, in some respects, that it gave an unprecedented impulse and popularity to the science; so disadvantageous was it in others, that it placed a formidable barrier in the way of all improvement. Vaillant, the able and worthy pupil of Tournefort, has never been forgiven for speaking, on some occasions, too freely of his master's defects. Hence his own merit has been kept in the background. The doctrine of the sexes of plants was discountenanced as long as possible, because it was proved by Vaillant, after having been rejected by Tournefort. Nevertheless, when the good seed of science is once sown, it can hardly be totally suffocated by the impediments of prejudice and ignorant partiality. Practical zeal sprung up by the side of speculative jealousy, and the tares withered, while the profitable plants flourished. Some botanists followed the steps of Tournefort to the Levant, exploring afresh those countries which he has forever rendered classic ground. Others visited America, which they traversed in different directions. The indefatigable Plumier performed three separate voyages to the western world, and though his discoveries have, in a great measure, suffered shipwreck from tardy and imperfect patronage, as a great part of his collections did, by the accidents of nature, yet something of value remains. His *Filices* are enough to insure his perpetual remembrance, and his *Nova Genera* are the basis of our knowledge of generic differences in West Indian plants. Most of all has been distinguished, among the French botanists who succeeded the times of Tournefort and Vaillant, the family of the Jussieus. One of these investigated the prolific regions of Peru, and discovered some things which no succeeding traveller has ga-

Botany. thered; other branches of this family, besides being eminent in medical science and practice, have pursued the study of botany with no ordinary success, on the most philosophical principles. Of these the most eminent are the celebrated Bernard de Jussieu, the contemporary of the earlier days of Linnæus; and his nephew Antoine Laurent de Jussieu, the pride and the ruler of systematic botany at present in France. The views and the performances of these great men lead us to a new branch of our subject, which indeed we have had in our contemplation from the beginning of this essay, the exposition of the principles of a natural scheme of botanical classification, as hinted, and imperfectly sketched, by Linnæus, and brought to the perfection of a regular system by the Jussieus.

Linnæan School in France.

Previous to our entering on this detail, and the remarks to which it will give rise, we must conclude all that belongs to the former part of our undertaking, by giving some account of those botanists who have formed and maintained a Linnæan school in France. We must shelter ourselves under the broad banner of truth when we observe that these have, till very lately, been almost the only French botanists that have supplied us with any practical information; and their labours have been useful in proportion as they have commendably shaken off the prejudices of their predecessors. Of this last proposition Duhamel is a witness, though we may perhaps excite some surprise in classing him among Linnæan botanists. His preface to his *Traité des Arbres* sufficiently shows how fearful he was of being taken for such, and yet how he was held by vulgar prejudice alone, to the nomenclature, or rather the generical opinions of Tournefort. He tells us, while he adopts these, that his judgment went with Linnæus, whom he follows in all new discoveries. The plan of his book, confined to hardy trees and shrubs, justifies his use of an alphabetical arrangement, in preference to any system, unless he had thought sufficiently well of Tournefort's to prefer that. But he has prefixed to his work, as a practical method of discovering scientifically what it contained, no other than a sexual classification. His practical botany was so limited, being entirely subservient to his great objects, of forest planting and vegetable physiology, that he had no attention to spare for the consideration of methodical systems. Accordingly he tells us, that some such is necessary for the use of botanists, especially of those who explore the productions of foreign countries, but whether the method of Ray, Tournefort, Boerhaave, Van-Royen, Linnæus, or Bernard de Jussieu be adopted, is of no importance. Six years before Duhamel's work came out, Dalibard had published, in 1749, his *Flora Parisiensis Prodromus*, according to the Linnæan system.

It has always appeared to the writer of this, from the conversation and writings of French botanists, that the judgment of the learned Le Monnier, and the countenance of his patron the Duke D'Ayen, afterwards Marechal de Noailles, first established the reputation of Linnæus in France; not so much possibly for the sake of his system, as his discoveries, his commendable nomenclature, and his clear principles of dis-

crimination. When Le Monnier botanized in Chili, in the company of the astronomers with whom he was associated, he soon found, like Dr Garden in South Carolina, that the classification of Tournefort was no key to the treasury of a new world. He however made his remarks and collections, and studied them subsequently under the auspices of a more comprehensive guide. The Marechal de Noailles, a great cultivator of exotic trees and shrubs, corresponded with the Swedish naturalist, and endeavoured to recommend him to the notice of the lovers of plants in France. Meantime Gerard and Gouan in the south, both introduced themselves to the illustrious Swede, and promulgated his principles and discoveries, though only the latter adopted his classification. Villars we have already noticed as the author of a Linnæan *Histoire des plantes de Dauphiné*. He died lately, Professor of Botany at Strasburgh, where he succeeded the very able and philosophical Hermann, one of the truest Linnæans, who had imbibed all the technical style of the Swedish school, as well as its accuracy of discrimination. We may now safely announce Hermann as the real author, in conjunction perhaps with Baron Born, of that ingenious but bitter satyr the *Monachologia*, in which the several species of monks are affectedly discriminated, and their manners detailed, like the animals in the Linnæan *Systema Naturæ*. This ludicrous performance has long since appeared in a, not very exact, English translation, and was rendered into French by the late M. Broussonet. As we are led again to name this amiable man, too soon lost to his country, after experiencing every vicissitude of revolutionary peril and alarm, we cannot help distinguishing him as one most zealous in the cultivation and diffusion of Linnæan learning, a taste for which he chiefly imbibed in England. He had no indulgence for those prejudices, which cramped the talents of his countrymen, and prevented their deriving knowledge from any quarter where it was to be had. He recommended the younger Linnæus to their personal acquaintance and favour, which service he also rendered, a few years after, to the person who now commemorates his worth, and who will ever remember, with affection and regret, his many virtues, his agreeable converse, and his various and extensive acquirements.

The intimacy which subsisted between this enthusiastic naturalist and the distinguished botanist L'Heritier, confirmed, if it did not originally implant, in the mind of the latter, that strong bias which he ever showed for the Linnæan principles of botany. According to these his numerous splendid works are composed. He moreover imbibed, if we mistake not, from the same source, a peculiar preference for uncoloured engravings of plants, instead of the coloured ones which had long been in use. It cannot be denied that the merit of these last is very various, and sometimes very small. They do, nevertheless, present to the mind a more ready idea of each species, than a simple engraving can do, nor is the latter less liable to incorrectness. When plates are taken from the delineations of such exquisite artists as L'Heritier employed, they have a good chance of excellence; but the engravings of

Botany. Cavanilles, done after miserable drawings, though they deceive the eye by their neat finishing, are really less exact than many a rude outline. Coloured plates, if executed with the uniformity and scientific exactness of Mr Sowerby's, or the characteristic effect of Jacquin's, speak to the eye more readily than most engravings. The art of printing in colours, practised formerly in England with small success, was revived at Paris by Bulliard, and is carried to the highest perfection in the recent publications of Redouté and Ventenat, which leave hardly any thing to be wished for, with respect to beauty or exactness. Many of the works of L'Heritier have remained imperfect, in consequence of the political convulsions of his country, and his own premature death. The learned and worthy Desfontaines, who travelled in Barbary, has been more fortunate in the completion of his labours. His elegant *Flora Atlantica*, in 2 vols. 4to, with finely engraved uncoloured plates, is classed and modelled on the plan of the Linnæan school. Such also is the plan of the works of that distinguished botanist La Billardiere, who, besides his account of New Holland plants, has published five elegant *decades* of new species from Syria. That scientific horticulturist M. Thouin, likewise a most excellent botanist, though he has scarcely written on the subject, is a correct pupil of the Swedish school. His general spirit of liberal communication, and his personal attachment to the younger Linnæus, led him to enrich the herbarium of the latter, with the choicest specimens of Commerson's great collection, destined otherwise to have remained in almost entire oblivion. A singular fate has attended the discoveries of most of the French voyagers, such as Commerson, Sonnerat, and Dombey, that, from one cause or other, they have scarcely seen the light. So also it has happened to those of Tournefort, Sarrasin, Plumier, and others, whose acquisitions have long slept in the Parisian museums. Happily there seems to have arisen of late a commendable desire to render them useful by publication, and thus many fine plants, known merely by the slight and unscientific appellations of Tournefort, and therefore never adopted by Linnæus, have recently been clearly defined, or elegantly delineated. The journeys of Olivier and Michaux towards the east have enriched the Paris gardens, and been the means of restoring several lost Tournefortian plants. We believe however that the English nurseries have proved the most fertile source of augmentation to the French collections, as appears by the pages of all the recent descriptive writers in France.

We dare not presume to arrange the indefatigable and very original botanist Lamarck among the Linnæan botanists of his country, but we beg leave to mention him here, as one who has thought for himself, and whose works are the better for that reason. His severe and often petulant criticisms of the Swedish teacher, made him appear more hostile than he really was, to the principles of that great man. Being engaged in the botanical department of the *Encyclopédie Méthodique*, he was obliged to conform to an alphabetical arrangement; but he surely might have chosen the scientific generic names for that purpose, instead of barbarous or vernacular

ones, which, to foreigners, would have made all the difference, between a commodious and an unintelligible disposition of his work. In the detail of his performance, he has great merit, both with respect to clearing up obscure species, or describing new ones, and he had the advantage of access, on many occasions, to Commerson's collection. Lamarck's *Flore Française*, is arranged after a new analytical method of his own. This book however is valuable, independent of its system, as an assemblage of practical knowledge and observation. We have only to regret a wanton and inconvenient change of names, which too often occurs, and which is not always for the better; witness *Cheiranthus hortensis*, instead of the long established *incanus* of Linnæus; *Melampyrum violaceum*, which is not correct, for *nemorosum*, which is strictly so, and which preserves an analogy with the rest of the species.

We shall now undertake the consideration of the principles that have been suggested, and the attempts that have been made, respecting a

NATURAL CLASSIFICATION OF PLANTS.

The sexual system of Linnæus lays no claim to the Sexual System merit of being a natural arrangement. Its sole aim^{tem.} is to assist us in determining any described plant by analytical examination. The principles on which it is founded are the number, situation, proportion, or connection, of the stamens and pistils, or organs of impregnation. These principles are taken absolutely, with the sole exception of their not being permitted to divide the genera, that is, to place some species of a genus in one part of the system, and others in another, though such may differ in the number, situation, proportion, or connection of their stamens or pistils; those characters being possibly artificial, while the genera are supposed, or intended, according to a fundamental law independent of all systems, to be natural assemblages of species. We need not here explain the mode in which Linnæus has provided against any inconvenience in practice, resulting from such anomalies of nature herself.

But though this popular system of Linnæus does not profess to be a natural method of classification, it is, in many points, incidentally so, several of its classes or orders whose characters are founded in situation, proportion, or connection, being more or less perfectly natural assemblages; nor can it be denied that, on the whole, it usually brings together as many groups of natural genera, as occur in most systems that have been promulgated. This fact would be more evident, if the various editors of this system, those who have added new genera to the original ones of Linnæus, or, in general, those who have any way applied his method to practice, had properly understood it. They would then have perceived that its author had always natural affinities in view; his aim, however incompletely fulfilled, according to our advanced knowledge, having constantly been, to place genera together in natural affinity or progression, as far as their relationship could be discerned. At the same time he uses an analytical method, at the head of each class in his *Systema Vegetabilium*, in which the genera are dis-

Botany.

posed according to their technical characters. Murray, in compiling the fourteenth edition of that work, has been inadvertent, respecting this essential part of its plan. Indeed it is probable that he was not competent to judge of the affinities of the new genera, introduced from the *Supplementum*, or from the communications of Jacquin, Thunberg, &c. Yet surely he might have perceived the affinity of *Banksia* to *Protea*, rather than to *Ludwigia* or *Oldenlandia*; and indeed Linnæus himself ought to have discovered the relationship of the latter to *Hedyotis*, if he did not detect their identity, instead of inserting it between two such strict allies of each other as *Ludwigia* and *Ammannia*. To pursue these remarks would be endless. It is hardly necessary to indicate the natural classes, or orders, of the Linnæan system, such as the *Tetradynamia*, *Didynamia*, *Diadelphia*, *Syngenesia*; the *Triandria Digynia*, *Gynandria Dianthia*, &c. Except the first-mentioned class, which, if *Cleome* be removed, is strictly natural and entire, the others are liable to much criticism. We are almost disposed to allow, what we know not that any one has yet observed, that the system in question is the more faulty in theory, for these classes being so natural as they are. Each order of the *Didynamia* presents itself as a natural order, though the character of that class, derived from the proportion of the stamens, serves to exclude several genera of each order, and to send them far back, into the second class. If all ideas of natural affinity be discarded from our minds, there is no harm whatever in this; but if the *Didynamia* claims any credit, as a class founded in nature, the above anomaly is a defect. So, still more, under the same point of view, is the *Diadelphia*, or at least its principal order *Decandria*, liable to exception. This order consists entirely of the very natural family of *Papilionaceæ*. They are characterized as having the ten stamens in two sets. Now it happens that there are many papilionaceous genera, indeed a great number of such have been discovered since Linnæus wrote, whose ten stamens are all perfectly distinct. These therefore are necessarily referred to the class *Decandria*, and they come not altogether amiss there, because they meet, in that class, some concomitant genera, which though, like them, leguminous, are less exactly, or scarcely at all, papilionaceous. But the greatest complaint lies against some genera of the *Diadelphia Decandria*, for having the stamens all really combined into one set, so as in truth to answer to the technical character of the preceding class, *Monadelphia*. There is mostly indeed some indication of a disunion upward, where they, more or less perfectly, form two sets; and some of them are so nearly diadelphous, that their complete union at the bottom may easily be overlooked; others, however, have only a fissure along the upper side of their common tube, without any traces of a separate stamen or stamens. The papilionaceous character of the *corolla* therefore, in such cases, is made to overrule that of the particular mode of union among the stamens, and is in itself so clear, as seldom to be attended with any difficulty; but the incorrectness of principle in the system, in the point before us, as being neither professedly natural, nor exactly

artificial, cannot be concealed. Part of the objections, to which the sexual system was originally liable, have been obviated. We mean what concerns the last class but one, *Polygamia*. Dr Forster observed, in his voyage round the world, that this class was subject to great exception, on account of the trees of tropical climates, so many of which are constantly or occasionally polygamous; that is, each individual frequently bears some imperfect flowers, male or female, along with its perfect or united ones. Such a circumstance reduces any genus to the class *Polygamia*; and on this principle Mr Hudson, thinking perhaps that he made a great improvement, removed our *Ilex Aquifolium*, or Holly, thither, though *Ilex* is well placed by Linnæus in the fourth class. The author of the present essay has ventured to propose a scheme, which is adopted in his *Flora Britannica*, for getting clear of this difficulty. He considers as polygamous such genera only as, besides having that character in their organs of impregnation, have a difference of structure in the other parts of their two kinds of flowers. Thus *Atriplex* has, in its perfect flowers, a regular spreading calyx, in five equal segments; in the attendant female ones a compressed one, of two leaves, subsequently much enlarged.

The genera thus circumstanced are so very few, as far as we have discovered, that possibly the class might, but for the uniformity of the system, be abolished. We cannot indeed tell what future discoveries may be made; and its character, on the above foundation, is sufficiently clear and permanent; for flowers of an essentially different configuration, can hardly vary into each other. The orders of the last class of the Linnæan system, *Cryptogamia*, are natural, and preserved, all nearly the same, by every systematic projector. The original appendix to this system, the *Palmeæ*, would be a great blemish therein, as an artificial arrangement: for such an arrangement ought to be so formed as to admit every thing, on some principle or other. But this stumbling-block is now removed. The palm tribe were placed thus by themselves, merely till their fructification should be sufficiently known. Now they are found to agree well with some of the established classes and orders, where they meet with several of their natural allies.

Whatever advantages might accrue to the practical study of botany, from the convenience and facility of his artificial system, Linnæus was from the beginning intent on the discovery of a more philosophical arrangement of plants, or, in other words, the classification of nature. This appears from the 77th aphorism of the very first edition of his *Fundamenta Botanica*, published in 1786, where he mentions his design of attempting to trace out fragments of a natural method. In the corresponding section of his *Philosophia Botanica*, he, fifteen years afterwards, performed his promise; and the same *Fragmenta*, as he modestly called them, were subjoined to the 6th edition of his *Genera Plantarum*, the last that ever came from his own hands. The interleaved copies of these works, with his manuscript notes, evince how assiduously and constantly he laboured at this subject, as long as he lived. He was accustomed to

Botany.

Natural
Classification
of Lin
næus.

Botany. deliver a particular course of lectures upon it, from time to time, to a small and select number of pupils, who were for this purpose domesticated under his roof. What this great botanist has himself given to the world, on the subject under consideration, is indeed nothing more than a skeleton of a system, consisting of mere names or titles of natural orders, amounting in his *Philosophia* to 67, besides an appendix of doubtful genera; and that number is, in the *Genera Plantarum*, reduced to 58.

Under the title of each order, the genera which compose it are ranged according to the author's ideas of their relationship to each other, as appears by some of his manuscript corrections; and some of the orders are subdivided into sections, or parcels of genera more akin to each other than to the rest. He ingenuously avowed, at all times, his inability to define his orders by characters. He conceived that they were more or less connected with each other, by several points of affinity, so as to form a map, rather than a series. The experienced botanist, who peruses the above-mentioned *Fragmenta*, will in most cases readily imbibe the ideas of their author, as to the respective affinities of the genera. In some few instances, as the *Dumosa*, where he avows his own doubts, and the *Holeraceæ*, where he is unusually paradoxical, it is more difficult to trace the chain of his ideas. Such however was all the assistance he thought himself competent to afford. His distinguished pupils Fabricius and Giseke fortunately took notes of his lectures on natural orders; and by the care of the latter, to whom Fabricius communicated what he had likewise preserved, their joint acquisitions have been given to the public, in an octavo volume at Hamburg, in 1792. Nor was this done without the permission of their venerable teacher, who told Giseke by word of mouth, when they took leave of each other, that "as he loved him, he had laboured with pleasure in his service;" adding, that "Giseke was at liberty to publish, whenever he pleased, any thing that he had retained from his own instructions."

Linnæus, according to a conversation with Giseke, recorded in the preface of the volume edited by the latter, declined to the last any attempt to define in words the characters of his orders. His reason for this appears in his *Classes Plantarum*, where he justly remarks, that no certain principle, or key, for any such definition can be proposed, till all the orders, and consequently all the plants, in the world are known. He has however so far expressed his opinion, in the work last quoted, as to point out the situation of the seed itself, with respect to other parts, and the situation and direction of its vegetating point, or *corculum*, as most likely to lead to a scheme of natural classification. Hence the system of Cæsalpinus stood very high in his estimation. He also, in the conversation above-mentioned, divides his own orders into three sections, or classes, *Monocotyledones*, comprising the first ten orders, with the 15th: *Dicotyledones*, (with two or more cotyledons), the 11th to the 54th order, inclusive, except the 15th; and *Acotyledones*, order 55th to 58th, with a hint that the last, or *Fungi*, ought perhaps to be altogether excluded. This distribution of plants, by

VOL. II. PART II.

the number or the absence of the cotyledons, or lobes of the seed, is the great hinge of all the professedly natural modes of arrangement that have been attempted. We shall for the present not enter on the consideration of this principle, as it will more properly be explained when we examine the system of Jussieu. Linnæus did not consider it as absolute, for he told Giseke that he knowingly admitted into his 11th order some plants that are monocotyledonous, with others that are dicotyledonous. The reason of this was the only secret he kept from his pupil, nor could the latter ever dive into it, though he afterwards endeavoured to learn it from the younger Linnæus, who knew nothing, neither did he, as Giseke says, much care, about the matter. We hope to be able to throw some light upon this mystery, when we come to the order in question.

The want of any avowed principle of distinction, precludes all criticism of these natural orders of Linnæus, as a regular system; we can therefore only take a cursory view of them as they follow each other, with such indications of their characters as Giseke has recorded, or as we may ourselves be able to trace. A great part of the substance of the lectures, published by him, consists of remarks on the genera of each order, as to their mutual distinctions; with numerous botanical and even economical matters, which do not all come within the compass of our present consideration. What we have to lay before the reader is not, in any manner, forestalled, by what he will find in the fourth volume of the *ENCYCLOPÆDIA*, above cited, which is taken from a different source.

Order 1. PALMÆ. "An entirely natural, and Linnæus's very distinct order." This tribe of plants, stationed exposition of his Natural Orders. by nature within the tropics, is considered by Linnæus as the original food of man; still supplying the place of corn to the inhabitants of tropical countries. Palms are the most lofty of plants, and yet it is a matter of doubt whether they ought to be called trees or herbs. They do not form wood in concentric circles, year after year, like our trees, though they are extremely long-lived. The author of the sexual system was, as we have just mentioned in speaking of that system, but little acquainted at first with the structure of the flowers of palms, or the number of their stamens or pistils. His predecessors in the establishment of genera of plants, Tournefort and Plumier, had published little or nothing illustrative of this tribe. He had himself seen no more than three or four species in fructification, nor had he any other resource, in founding genera, than the plates of the *Hortus Malabaricus*, (excellent indeed, but not delineated with any particular view of this kind,) and the less complete representations of Rumphius. The growth of these plants is quite simple. Each terminates in a bud, of a large size, called the heart, or by voyagers in general the cabbage, of the palm. When this is cut off, the tree dies, though the growth of many centuries. This bud has a gradual and nearly continual vegetation, unfolding its leaves, which Linnæus rather incorrectly terms fronds, one after another in succession, not all at any particular season. The bud therefore is perennial, not, as in our trees, annual, nor can it, for

3 D

Botany.

this reason, be renewed. Fresh buds, in time becoming trees, are furnished from the generally creeping, perennial, and deeply descending roots. What have commonly been denominated the branches of Palms, Linnæus very properly declined calling so, because they never increase by producing lesser branches. He objected to calling them leaves, "because they are each attended by no separate annual bud, neither have they the texture of ordinary leaves, nor do they wither and fall off at any particular season." He adopted the term *frond*, which he always used when he could not decide whether the part in question were a branch, leaf, or stem. We cannot but think these are truly leaves, though it must be confessed they differ from the generality of such, in being destitute of any line of separation by which they are capable of falling, or being thrown off, from the stem. In this they agree with the foliage of *Musci* and *Jungermanniæ*; there being a perfect continuity of substance throughout. The hardened torn fibres, or rather vessels, which remain on the stems of palms, where the leaves have once been, are precisely the same as what occur in various mosses; and something similar may be observed in many liliaceous plants and their allies, which approach to the nature of palms.

In describing the fructification of this order, Linnæus considered as belonging thereto, what we should presume to be rather the inflorescence. Hence the great branching flowerstalk retains, in a technical sense, the name of *spadix*, derived from the ancients; and its ample containing sheath is denominated a *spatha*. The latter is reckoned a kind of calyx, as the former a sort of branched common receptacle. Linnæus strengthens his terminology in this case, by tracing an analogy between the *spatha* of palms, and the glume of grasses. We doubt whether any such particular analogy exists. Neither does his other comparison, of the part in question to the sheath of a *Narcissus* and its allies, at all, as far as we can judge, elucidate or confirm his principle. He surely swerves in these instances, as well as in his generic distinctions of the umbelliferous plants, from the correctness of an axiom, on which botany as a philosophical science depends, that generic characters, and much more those of classes and orders, should be exclusively derived from the parts of fructification. Surely a very slight consideration of the flowers and fruits of the *Palmeæ*, as we have become acquainted with them since the time of Linnæus, will abundantly satisfy any person, that they afford clear characters, on which to found a sufficient number of distinct and very natural genera. Even that author, in the lectures before us, records that some genera have a three-leaved *calyx*, others none at all; some have a *corolla* of three, others one of six, petals; most have six *stamens*, some three, others nine, while the *Nipá* of Thunberg has only one. The *germens* are three in some, solitary in others, and the *style* and *stigma* are subject to like diversity in different genera. The *fruit* is in some, as the *Phoenix dactylifera*, or Date, a single drupa, in others composed of three; in some, like the *Cocoa*, a nut with a coriaceous coat. The *seeds* are mostly solitary, but in several instances two or

three in each fruit. Hence, while the fructification affords sufficient materials for discriminating genera, Linnæus observes that no common character, exclusively descriptive of the whole order, can be founded upon it. The reader will find the essential characters of his genera in our Vol. IV. 288. His *Zamia*, concerning which he avowed considerable doubts, chiefly because it wanted a *spatha*, is now, by common consent among botanists, removed either to the Ferns, or to an intermediate order between them and the Palms, to which also *Cycas* belongs. The technical characters which have induced this alteration, are confirmed by circumstances attending the habit and qualities of these genera.

At the end of his proper *Palmeæ*, Linnæus subjoins, in a distinct section, three genera, which he was doubtful whether to leave there, or to establish as a distinct order. These are *Stratiotes*, *Hydrocharis*, and *Valisneria*. He remarks in his lectures that "they have a *spatha* extremely like the palms; a calyx of three leaves, and a corolla of three petals; leaves perennial and evergreen, folded when they first come forth. *Hydrocharis* cannot be separated from *Stratiotes*, nor *Valisneria* from *Hydrocharis*. They produce their leaves crowded together at the base, like Ferns. Although their strict affinity with the larger Palms of India cannot be demonstrated, they ought nevertheless to be associated therewith. They are all aquatics, whence we may presume that India may afford some aquatic palms, smaller than the others, which may prove a connecting link between the latter and the plants of which we are speaking." Giseke points out several palms, in various authors, which though but imperfectly ascertained, confirm this conjecture of his preceptor. Linnæus in his own copy of the *Genera Plantarum*, enriched with his manuscript notes, to which we shall often refer, has marked this section, or appendage, of his *Palmeæ*, as distinguished by "an inferior fruit, with many seeds." He has moreover added 4 genera to this assemblage, *Pandanus*, *Bromelia*, *Tillandia*, and *Burmanna*. Giseke has amply illustrated the order of *Palmeæ*, by observations of his own, or those of various writers; but the most solid acquisitions to our knowledge, in this interesting tribe, are derived from the labours of Dr Roxburgh, in his *Plants of Coromandel*.

Order 2. PIPERITÆ. "The plants of this order have an acrid flavour, whence the name." They afford no common character to discriminate the order, except possibly the elongated receptacle and sessile anthers, but some *amentaceæ* have the same. They consist of *Zostera*, *Arum* and its allies, *Orontium*, *Acorus*, *Piper*, and *Saururus*. The last is removed by Linnæus in his manuscript to his 15th order.

Order 3. CALAMARIÆ. "These are closely related to the true grasses, and have almost the same kind of leaves. Their seed is solitary and naked; stamens three; style one, not unfrequently three-cleft at the summit. Their glume is of one valve (whereas most grasses have two valves), except *Schaenus*, which bears several valves irregularly disposed, though in other respects so near the rest of its order, as scarcely to be distinguished without accurate examination of the parts alluded to. The stem of these plants is

Botany.

Botany. a *culm*, mostly triangular, rarely round, often leafless, or nearly so. Leaves rather rigid and rough. Flowers often disposed in an imbricated manner. Seed in a few instances surrounded with bristles. When these are extended into a kind of wool, hanging out beyond the scales, such a character marks the genus *Eriophorum*." Linnæus asserts that "*Scirpus* differs from *Carex*, in having all the flowers united, whereas in the latter some scales are accompanied with stamens only, others with pistils;" but he forgot the tunic, or *arillus*, of the seed, which makes the essential and clear character of *Carex*. He mistakes also in supposing the stamens are always three in this order; in several instances they are but two, in a few they are solitary. Much has been done respecting the genera and species of this order by Rottboll, Vahl, Brown, Schrader, and others. Linnæus has made a manuscript correction in the *Calamariæ*, excluding from thence *Typha* and *Sparganium*, which he would remove to the preceding order, principally, it seems, because he judged the latter to be very closely allied to *Zostera*; as well as on account of its anthers, but we can trace no resemblance in those to the *Piperitæ*. On the contrary they and their filaments agree with the *Calamariæ*. The stamens of *Typha* indeed are somewhat different, and Mr Brown, in his *Prodromus Floræ Novæ Hollandiæ*, has anticipated this alteration of Linnæus.

Order 4. GRAMINA. "The true grasses compose as peculiar a family as the palms. They are the most common plants in the world, making about a sixth part of the vegetable kingdom, especially in open situations. There they multiply, and extend themselves by their creeping roots, prodigiously. In confined and woody places they scarcely creep, but stand erect. They are the most important of all vegetables, for this reason, that they are the chief support of such animals as depend on vegetable food. They make the verdure of our summers, and the riches of rustic life. Their leaves are not easily hurt by being trampled on, and though the severity of winter may wither and fade them, so that in the early spring no appearance of life remains, yet they revive. The solicitude of the Author of Nature, for the preservation of this important tribe of vegetables, appears from their flowering stems being rendered unfit for the food of cattle, that nothing may hinder the perfecting of their seeds. Besides, the more they are cut and ill-treated, the more vigorously they grow, propagating themselves proportionably under ground; and in order that they may be enabled to thrive any where, their narrow leaves are so contrived, as to insinuate themselves between the divisions or branches of other herbs, without any mutual impediment. There are very few grasses agreeable to our palate. For the most part they are insipid, like pot-herbs; a very small number being fragrant. None are nauseous or poisonous. Grasses are the most simple of all plants; having scarcely any spines, prickles, tendrils, stings, bractæas, or similar appendages to their herbage."

"Their stem is termed a *culm*, being hollow, composed of joints which are separated by impervious knots. In our quarter of the world the culm is

usually simple, unless in consequence of cutting away the flowering part; in the Indies most culms are branched. The leaves are mostly alternate, always undivided, and generally flat on both sides, with a rough edge, and either smooth or hairy surface. Each leaf stands on a sheath, which embraces the stem, and is crowned with a membrane, sometimes termed *ligula*, closely embracing the stem, to hinder the admission of water. The sheath springs from a knot, and (with its membrane) answers the purpose of a stipula."

"The fructification of Grasses differs so much from that of other plants, that it was supposed impossible to reduce them to scientific order. They were first distinguished into corn and grasses; but such a distinction is founded merely on the comparatively larger seeds of the former, on which we depend for food, as small birds do on the very minute seeds of the latter. Ray was the first botanist who undertook a regular examination of grasses. He distributed them according to their outward appearances, but distinctive characters failed him. Neither was Tournefort, however great a botanist, equal to the arrangement of this tribe. Monti followed Ray, but investigated such only as were natives of Italy. John Scheuchzer, first induced by Sherard, paid a most laborious attention to this subject, collecting grasses from all quarters, and describing them with the greatest exactness; but he was deficient in technical terms, and his very long descriptions are nearly all alike, till he arrives at the flowering part. The terms which he uses are *folliculus* for the corolla, *gluma* for the calyx, *locusta* for the spikelet contained in the latter. After him Micheli contrived a new method, dividing grasses according to their spikelets, which he observed to be either compound or simple. He subdivided them by their flowers being united or separated; and subjoined an order of plants "akin to grasses," which really do not belong to them. If their sexes be attended to, the arrangement of grasses becomes less difficult. They are either *monandrous*, *diandrous*, *triandrous*, or *hexandrous*. The two latter have either united, monoecious or polygamous flowers."

"The inflorescence in this order of plants is either spiked or paniced. Their spike, properly so called, consists of several flowers, placed on an alternately toothed *rachis*, or stalk. If such a rachis be conceived perfectly contracted, it will become a toothed common receptacle, as in compound flowers, so that grasses may thus be distinguished into simple and compound. Or if we imagine all the flowers to be sessile on one common base, such grasses as are properly spiked will have a scaly receptacle, the rest a naked one, according to the analogy of the syngenesious class; and by this means the corn family may be separated from the rest, for they are scaly."

"The calyx is a husk of two valves, one proceeding from within the base of the other, like the claw of a crab. These husks are concave, and truly the leaves of the plant in miniature. The calyx contains one, two, or more, florets, which are constructed in the same manner, of two leafy husks, called by Linnæus petals, to distinguish them from the former. Within the petals the receptacle bears two very

Botany.

Botany.

minute, roundish, pellucid, extremely tender, withering scales, often invisible without a magnifier, which Micheli termed petals, Linnæus nectaries. Stamens generally three, in a few one, two, or six, with capillary filaments, and oblong incumbent anthers, whose lobes become separated at each end. Micheli erroneously imagined those which have six stamens, to bear, as it were, doubled flowers. The germen is superior, with two styles, sometimes raised on a common stalk or elongated base, and they are usually reflexed to each side, being either longitudinally hairy, or tufted at the summit only. Seed universally solitary, without a capsule, *Lygeum* only having a nut, of two cells, which is very singular. A few have a simple style, as *Zea*, *Nardus*, and *Lygeum*. The seed is occasionally coated by the petals, which closely enfold it, and are almost united with it, witness *Hordeum* and *Avena* ;” (to which examples indicated by Linnæus we may add *Briza*). “Many grasses are furnished with an awn, *arista*, mostly rough, like a prominent bristle, inserted into the back of the outermost petal, either at the bottom, middle, summit, or a little below the latter. This appendage is either straight, or furnished with a joint, and twisted backward, or simply recurved ; in some it is woolly ; in several it is accompanied by hairs at the base of the corolla. The use of these parts is to attach the ripe seeds to the coats of animals, that they may be the more dispersed.”

“Although grasses are destitute of spines properly so called, a few have their leaves longitudinally involute, in such a manner that their rigid permanent points have all the properties of thorns, as in *Spinifex*, and some *Festuca*. Their foliation is, for the most part, involute, but in some instances, as *Dactylis glomerata*, it is folded. This character has not as yet received sufficient attention, but ought to be noticed in future, as it may throw great light on the distribution of the family of plants in question. Very few indeed are furnished with setaceous leaves.”

Order 5. TRIPETALOIDEÆ. “Scheuchzer and other authors have referred *Juncus* and its allies to Grasses, under the title of *Graminibus affines*. In truth, they are so similar to grasses, as scarcely to be distinguishable without fructification. The genera are *Juncus*, *Aphyllanthes*, *Triglochin*, *Scheuchzeria*, *Elegia* and *Resio* in the first place, then *Flagellaria*, *Calamus*, *Butomus*, *Alisma* and *Sagittaria*.” Linnæus, in his manuscript, has hinted, that the three latter may possibly belong to the above-mentioned section at the end of his *Palma* ; see Ord. 1.

Order 6. ENSATÆ. “So called from the form of their leaves, resembling a sword, being perfectly simple, almost linear, alternate, mostly converging by the margins, often cloven longitudinally, so that the edge of one leaf embraces the other, thus constituting what is termed equitant foliage. The root in many cases is oblong and fleshy, lying flat on the ground, or creeping. But some species of *Iris* are truly bulbous, like *Crocus*, *Ixia*, *Antholyza*, &c. Stem, in these genera, simple, erect, zig-zag ; but in *Commelina*, especially the annual kinds, it is branched, as in *Tradescantia*. *Crocus* and *Bulbocodium* have no stems. Leaves usually sword-shaped ; very rarely quadrangular ; in the bulbous species of

Botany.

Iris involute ; in not a few *Commelina* ovate ; in *Xyris* and various kinds of *Eriocaulon* awl-shaped. *Fulcra*, or appendages, are scarcely to be found in this order. The calyx is a *spatha*, though but of a spurious kind, being mostly a large concave valve, resembling a halved sheath in *Iris* ; most beautiful in *Commelina*, where it is heart-shaped. In *Sisyrinchium* however this part is more perfectly bivalve. Corolla generally of six petals ; though in *Iris* so united by their claws, as to constitute a monopetalous corolla. In *Commelina* and *Tradescantia* the petals are very distinct, but the three inferior being ruder in texture, and smaller, resemble a calyx. Style with three stigmas, except some *Commelina*. Pericarp a capsule of three cells and three valves, with many seeds ; generally inferior, but not so in *Commelina*, *Tradescantia*, and *Callisia*. Hence it follows that this order affords no certain mark, on which a distinctive character could be founded.”

Order 7. ORCHIDÆ. “Orchis is a most ancient generic appellation, alluding to the testicular shape of the roots, in many plants of this family, which have, at all times, been believed to possess a stimulating, or aphrodisiacal virtue. All the *Orchideæ* might be comprehended in one genus, in which light also the *Umbellatæ*, *Semiflosculosæ*, *Papilionaceæ*, might each likewise be considered. But the science would be overwhelmed in confusion by such extensive genera, which it is therefore found necessary to subdivide.

“Many *Orchideæ* have a tuberous fleshy root ; not properly to be termed bulbous, because its fibres are thrown out from the top, or crown, whereas true bulbs produce their fibres from the base. These tubers, or knobs, are mostly in pairs ; some of them globose and undivided, others palmate, like the hand. One of these tubers, from whence the plant of the present year has come, being exhausted, will swim in water ; the other, destined to blossom next season, is so solid as to sink. In the palmate kinds, the former is vulgarly called the hand of the Devil, the latter the hand of God. *Ophrys corallorrhiza* however has a threadshaped, branched, and jointed root ; that of *O. bifolia* is perfectly fibrous. In other genera, particularly *Epidendrum*, the root consists of clusters of fibres.”

“The stem is solitary and herbaceous, except in several kinds of *Epidendrum*, quite simple, often leafy. In some however there is merely a leafless, radical flowerstalk, generally round, though not so in *Ophrys Loeselii* and *paludosa*. The leaves are simple, alternate, undivided, sheathing the stem ; sometimes wanting, as in *Orchis abortiva*. Appendages none at all, except bractens. Inflorescence terminal, either spiked or racemose. Fructification irregular, and very singular, for it is impossible to say what is calyx, and what corolla ; nor is this point of much importance, nature having placed no limits between them. There are five petals ; besides a nectary, which makes, as it were, a sixth. These five seem to constitute an upper lip, the nectary an under one. Or it may be said that the corolla is composed of three outer, often ruder, petals ; and three inner, the lowermost of which ought rather to be denominated a nectary. This last is various in

Botany. different genera, having its appropriate figure and dimensions, while the rest of the petals are more uniform. Sometimes the middlemost of the five petals, composing the upper lip, (like that of a ringent or helmet-shaped flower,) is more erect and dilated; but I have received some species from the Cape of Good Hope, in which these petals are united to each other, and elongated at their common base into a spur. Such will constitute a new division or genus, of this family, as it stands in the *Species Plantarum*, many of which have a spur from the base of the lower lip, or nectary. The petals however do not afford sufficient distinctions, for genera or species. The former are determined by the nectary, which is for that purpose principally to be regarded. There is indeed no occasion to advert to any other part than the flower of these plants, for distinguishing either genera or species. Vaillant therefore, and Seguier, have contented themselves with delineating their various flowers alone."

"The stamens consist of two anthers, nearly without filaments, very singular, and peculiar to this order, concealed in a double pouch or hood, but their pollen has not been ascertained. They are "contracted at the base, naked, or destitute of a skin, divisible like the pulp of an orange, and covered each by a cell open underneath, inserted into the inner margin of the nectary;" as described in the *Genera Plantarum*. It remains therefore for inquiry, whether the anthers burst in these as in other stamens, and whether the pollen explodes upon the female organs? or whether there be any internal communication between the anthers and germen?" This latter opinion Linnæus was inclined to adopt, because, (as he thought), "the pistil was so obscure, that no one was able to say whether there were any style or stigma." We cannot but remark here that the latter is sufficiently apparent, in the form of a shining glutinous depression or cavity, just below the anthers; nor is there any doubt that the pollen, though different in texture from other plants, and various in the different species of these, performs the office of impregnation by the stigma. It consists of naked elastic or granular masses, being what Linnæus terms the anthers.

"The germen is inferior in the whole order; the style short, inclining, in many hardly manifest, in some American *Orchideæ* very conspicuous. Stigma either obsolete, or funnelshaped, sometimes compressed. A small gland moreover is present, suspected to belong to the female organs of impregnation, but not very decidedly." (Linnæus surely errs in asserting that the sexes of the plants in question are very obscure.) "The fruit is a capsule, of one cell, and three valves, which last are connected by a lateral suture, to which the seeds are attached, as to a receptacle. The capsule does not burst in the usual manner, but the valves separate at their lateral sutures, while their extremities remain united at top and bottom. The seeds are numerous, of a chaffy appearance, like saw-dust."

"Many fine species of this order are found in Europe and America; the Cape of Good Hope is not rich in them;" (Mr Brown observed a consider-

able number there;) "both Indies abound with singular ones, especially with *Epidendra*. Their favourite soil is a spongy, moist, friable, rich, but not manured, earth, in rather shady situations. The species of *Epidendrum* are all, perhaps, parasitical, insinuating their roots into the bark of aged trees."

"*Orchideæ* are extremely difficult of culture." We refrain from transcribing the ideas of Linnæus on this subject, as it is now known that some of these plants may be propagated by seed, and that several succeed very well in our stoves, among the rotten bark of trees, accompanied by fresh vegetable mould. Our wild Orchises are best removed when in full bloom, when the mould should be entirely cleared away from their roots, and the latter planted immediately in fresh sifted soil from their native place of growth, with moderate subsequent watering. Thus treated they will come up and flower for many successive years in the same pot.

Order 8. SCITAMINEÆ. "These nearly approach the *Orchideæ* in aspect. The name of the order is an ancient word, synonymous with *aromatic*, and answers to the whole of the tribe, except *Musa*, *Heliconia*, and *Canna*." (The two former certainly do not belong to this order, and the last but imperfectly.)

"The roots of the *Scitamineæ* are fleshy, mostly acrid and aromatic, lying on the surface of the ground, and throwing out fibres from their under side, like some of the 6th order. Stem always quite simple," (to this there are exceptions in *Marantia*); "in some bearing alternate leaves; in others naked, and separate from the foliage. Leaves lanceolate, quite entire, even, stalked, convoluted contrary to the direction of the sun; their stalks sheathing the stem. Inflorescence either a spike or cluster, the flowers being separated by coriaceous or membranous bracteas. Flower superior. Calyx a perianth of three valves. Corolla always irregular. Pericarp in most instances a capsule of three cells and three valves, with many seeds in each cell." We pass over much of the Linnæan description, recent discoveries having enabled succeeding writers, particularly Mr Roscoe, in *Trans. of Linn. Soc.* Vol. VIII. and Mr Brown in his *Prodr. Nov. Holl.* to explain the flowers much better. The corolla is monopetalous, with a double limb, and more or less irregular; each limb in three deep segments; the inner most unequal, one of its segments being a dilated, lobed, ornamented lip, like that of the *Orchideæ*, the other two sometimes very small, or obsolete. Stamen one, inserted into the tube, opposite to the lip; its filament mostly dilated, and of a petal-like habit, by the diversity of whose shape Mr Roscoe has first reduced this order into natural genera, a matter in which preceding botanists had altogether failed. The anther consists of two parallel distinct lobes, united lengthwise with the filament, bursting longitudinally, sometimes spurred at the base. There are usually the rudiments of two abortive stamens, first asserted to be such by Mr Brown. Germen roundish, with a threadshaped style, lodged between the lobes of the anther, and a dilated, cup-like, often fringed, stigma.

"To this order belong the Ginger, Cardamoms,

Botany. Grains of Paradise, *Costus*, Galangals and Zedoary of the shops, all aromatic. We have nothing similar to them in Europe, except *Acorus*."

What Professor Giseke has subjoined to the lectures of Linnæus, relative to this order, is, to say the best of it, superfluous.

Order 9. SPATHACEÆ. "These are distinguished by their bulbous root, consisting of a radical bud, formed from the bases of the last-year's leaves, which envelope the rudiments of the future foliage. In a bud the scales are expanded into leaves; in a bulb the permanent base of the leaves becomes fleshy. In this order the leaves are sheathing at the root, so that they exhibit no instance of a scaly bulb, but only a coated one. Their leaves are, with a few exceptions, almost linear, or linear-lanceolate. Stem no other than a *scapus*, or radical flowerstalk, either round, two-edged, or triangular. The *spatha*, or sheath, is a terminal membrane, splitting lengthwise, except in *Hæmanthus*, where it divides into six segments, resembling an involucre, and is permanent. The *spatha* sometimes contains many flowers, and where it naturally bears but one, is liable occasionally to produce more. The flowers are stalked within the *spatha*; in most instances they are superior, but not in *Bulbocodium*, whose corolla is divided to the very base. This plant therefore has erroneously been referred to *Colchicum*. *Tulbaghia* has a perfectly inferior flower, but cannot be referred to *Hyacinthus*, on account of its many-flowered *spatha*." (The nectary, or crown of the tube, abundantly distinguishes it.) "*Allium* has invariably an inferior flower, but its *spatha* shows that it belongs to the order before us. Some of its species bear flowers as big as a *Narcissus*."

"The corolla in most of the genera is monopetalous, inasmuch as the nectariferous tube bears the petals. Otherwise they might all be denominated hexapetalous, except *Colchicum* and *Crinum*; to say nothing of *Gethyllis*, distinguished from all the rest by its very long tube. Stamens six, except in the genus last mentioned, where they are twice that number. Pistil one, except *Colchicum*; but many have a three-cleft stigma, so that in *Colchicum* this part may be considered as only further divided even down to the germen. Capsule in all of three cells, with many seeds." (*Hæmanthus* has a berry.)

"The roots of this tribe grow best if they are dried after the leaves perish, either artificially, or by the arid nature of their place of growth. Many of these roots are nauseous and acrid, therefore poisonous, especially *Colchicum*. The bulb of a *Narcissus* will kill a dog. No analogy holds good between these plants and the Tulip, whose bulb may be eaten with impunity; because they are not of the same natural order. All the species of *Allium* are impregnated with their own peculiar pungent flavour, and nature being disposed to expel them with violence from the stomach, they prove most powerful sudorifics. Much of the substance of these last mentioned is mucilaginous, which involves and separates their acrid particles. Hence they are not dangerous in substance, but their expressed juice, deprived of viscosity, is fatal."

Order 10. CORONARIÆ. "A coronary or garland

flower was anciently such as, on account of its beauty, was used for ornamental wreaths."

"*Ornithogalum* has much in common with *Allium*, but wants the *spatha*. *Scilla* is so nearly related to *Ornithogalum*, that they are scarcely to be distinguished but by the breadth" (some say the proportion) "of their filaments. *Hyacinthus* and *Scilla* are with difficulty distinguishable, though the latter has six petals, the former a monopetalous six-cleft corolla, but this is in some instances so deeply divided as nearly to approach the latter."

"In this order the root is either tuberous, a solid bulb, or, as in *Lilium*, a scaly one. The leaves of *Aloe*, *Yuoca*, *Agave*, and *Bromelia*, are, as it were, a bulb above ground, whose dilated, fleshy, permanent scales remain year after year; just as the bulb of the Lily consists only of the perennial bases of the foliage. In the *Aloe* tribe, not merely the base, but the whole leaf is perennial. Whoever is ignorant of this, cannot fail to go astray in studying the order in question."

"The stem is simple, often a mere *scapus*, occasionally leafy, in consequence of a partial elevation of the radical leaves."

"The flower, destitute of *spatha* or any sort of calyx, consists of six petals." (Linnæus terms them such, because they fall off when the flowering is over.) "In *Ornithogalum* some species have the under side of the corolla green, which part therefore is permanent here, as consisting of corolla and calyx united. In some kinds of *Anthericum*, and in *Veratrum*, the petals are likewise permanent, but in a faded condition. The stamens are universally six, three of them interior. Germen superior. In *Aloe* the pistil is solitary, and three-cleft; but the style is divided to the very base into three parts in *Melanthium*, *Helonias*, *Veratrum*, and one species of *Ornithogalum*. All the tribe have a capsule of three cells, and three valves, the seeds being placed one above another."

"There is no uniformity in the qualities of the *Coronaria*, there being among them a great diversity of scent. The nauseous smell of *Fritillaria imperialis* and *Veratrum* indicates a very poisonous quality, of which likewise *Aloe* partakes. *Lilium* is mild; its root inodorous and mucilaginous; its qualities therefore are emollient and lubricating. *Scilla maritima* is in the highest degree acrid and diuretic, dissolving viscid humours. The root of *Ornithogalum umbellatum*, as well as of *O. luteum*, is eatable. The former appears to be the Dove's dung, sold for so high a price during the siege of Samaria, as recorded in the Second Book of Kings, chap. vi. v. 25; in the first place, because it is very abundant in Palestine, whence the English call it Star of Bethlehem; secondly, because the flower resembles the dung of pigeons and other birds, in its greyish and white partycoloured hue, whence also comes the name *Ornithogalum*, or bird's milk, alluding to the white substance, always accompanying the dung of these animals; and lastly, because the root in question is to this day eaten in Palestine, at least by the poor." (See *English Botany*, t. 130.)

"Wepfer has proved, by many experiments, the very poisonous nature of the root of the Crown Imperial, which kills dogs, wolves, and various other

Botany.

animals. The ancients relate that the honey of its flowers caused abortion. No flower, except *Melanthus*, produces more of this fluid, yet the bees do not collect it! We owe this fine plant, now so common, to Clusius, who more than two hundred years ago received it, along with the Horse-Chesnut, from the east. He likewise acquired many other bulbs, before unknown, now become the ornaments of our gardens. From his time, no one has taken the same pains. Certainly if any person could travel, for this object, into the interior of Persia and the kingdom of the Mogul, he would be likely to obtain many superb plants of this order, as recent travellers to the Cape of Good Hope have made us acquainted with so many novelties among the *Ixia*, *Antholyza*, &c. of which Hermann, Oldenland, &c. their predecessors, have not mentioned a word. *Tulipa Gesneriana* is so called, because it was procured by Conrad Gesner, from Cappadocia, whence it has become common throughout Europe: its endless varieties are the delight of florists, and some of them fetch a high price."

Linnæus in his own manuscript has, as we have already said, removed *Bromelia*, *Tillandsia*, and *Burmannia*, from this order to the *Palma*, or at least an appendix thereto.

Order 11. SARMENTACEÆ. "Sarmenta among the ancients meant unarmed, prostrate, weak branches, unable to support themselves; hence this name is applied to the order before us, many plants belonging to which answer to that character, being of a long, weak, trailing or twining habit. The *Sarmentaceæ* are monocotyledonous. They differ much in fructification, and may be variously arranged; either by their calyx and corolla; the number of their stamens or of their pistils; the nature of their fruit; or the inferior and superior situation of their germen. Hence it appears that no common character, applicable to the whole order, can be deduced from the fructification."

"*Raiania*, *Tamus*, *Dioscorea*, *Smilax*, *Cissampelos*, *Menispermum* and *Ruscus*, form one assemblage, all except the last having the above-mentioned kind of stem, twining to the left, not to the right, except in one species of *Menispermum*. Such a difference is rare between plants of the same natural order. *Smilax* supports itself by two tendrils, springing from near the base of the footstalks; all the rest are spiral, and without examination of the fructification, may easily be confounded. The above are dioecious, except one or two species of *Ruscus*." (*Centella* ranged among these in *Gen. Pl.* is now referred to *Hydrocotyle*.)

"*Dracæna*, *Asparagus*, *Convallaria*, *Uvularia*, *Gloriosa* and *Erythronium*, compose another section. The last is intermediate, as it were, between the present order and the *Coronariæ*. *Gloriosa simplex* is a small plant, not unlike *Erythronium*, with reflexed petals." (What Miller, who is Linnæus's sole authority for this species, intended, nobody has ever been able to make out.)

"*Medeola*, *Paris* and *Trillium*, have whorled leaves, except *M. asparagoides*, which scarcely differs from the genus *Asparagus*, except in having three styles instead of one."

Botany.

Aristolochia, *Asarum* and *Cytinus*, nearly akin to each other, are removed from this order, by the author in his manuscript, to the 27th, *Rhoeadeæ*, but not without a query. In the same place we meet with what may perhaps prove a solution of the mystery, which Giseke was so anxious to unriddle, and to which we have already alluded in the beginning of this part of our subject. Linnæus has here mentioned *Nymphæa*, as having in some of its species one cotyledon, in others two. He notes also that *Menispermum* and *Aristolochia* are dicotyledonous. *Nymphæa* however appears to be the great secret, which the worthy professor told his pupil, that he, or some other person, might chance to find out in ten, twenty or fifty years, and would then perceive that Linnæus himself had been aware of it. Accordingly, Gærtner and Jussieu have made the same discovery, or rather, fallen into the same mistake; describing *Nymphæa* as monocotyledonous, and *Cyamus* Sm. Exot. Bot. v. i. 59. (their *Nelumbo*, or *Nelumbium*), as in some measure dicotyledonous. The excellent De Candolle, in the *Bulletin des Sciences*, n. 57, published in 1802, has first rightly considered both as dicotyledonous, and akin to the *Papaveraceæ* of Jussieu, the Linnæan *Rhoeadeæ*.

Linnæus, in his lectures, proceeds to observe, that he "wanted to make further inquiry into the cotyledons of his *Sarmentaceæ*, for though he knew that several of these plants were monocotyledonous, he knew two, and did not doubt there were more, perfectly dicotyledonous. Hence he suspected the order might be separated into two, in other respects very closely related."

"The roots of all this family are oblong and fleshy, except *Erythronium*, whose radicles are long and quite simple; those of *Smilax Sarsaparilla* run very deeply into the ground, and are sometimes so thickened at the ends as to become tuberous. The stem at first coming forth is smooth and leafless, mostly branched, except in *Paris* and *Trillium*; in some prostrate. Leaves in every instance simple and undivided, sometimes linear, sometimes lanceolate and acute, or heartshaped, uniform, mostly alternate; except when three or more stand together in a whorl, and in *Dioscorea oppositifolia*. It is rare that alternate and opposite leaves occur in the same natural order. Flowers mostly on simple stalks, *Smilax* excepted, which has umbels; they are drooping except in *Paris*. Stamens universally six, except in *Menispermum*. Styles three, or three-cleft. All the genera, almost without exception, are deficient in either calyx or corolla. The fruit is generally of three cells. Inflorescence axillary in all except *Erythronium*, which has but one flower, and *Ruscus*, where it springs from the leaf."

"Their qualities are to be judged of by the smell. All of them betray something of malignity, except two insipid ones which are eatable, *Dioscorea* and *Asparagus*. *Gloriosa* is very poisonous; the dried flowers of Lily of the Valley cause sneezing, like *Veratrum*, that is, they produce convulsions. *Paris* has always been deemed poisonous. One kind of *Cissampelos*, named *Pareira brava*, and *Smilax*, are known by physicians to be highly diuretic, as

Botany. well as the roots of *Asparagus*. *Menispermum Cocculus* kills fishes, lice, and men."

"This whole order is entirely without pubescence, even the prickly *Smilaces*."

Next follow the Dicotyledonous Orders.

Order 12. **HOLERACEÆ**, pot-herbs, (erroneously printed *holoracææ* in Gen. Pl. which has misled several writers). "This denomination is given to plants that are tender or brittle in the mouth, and easy of digestion, like many of the order before us." The order is divided into several sections. Of the first *Blitum*, *Atriplex*, *Chenopodium*, *Salsola*, *Salicornia*, &c. are examples. The second consists of *Petivoria*, *Calligonum*, *Ceratocarpus* and *Corispermum*. *Callitriche* was subsequently removed to the 15th order. In the third section *Azyris* stands alone. Of the fourth *Herniaria*, *Illecebrum*, *Amaranthus*, *Phytolacca*, may serve to give an idea. The fifth begins with *Begonia*, (of whose affinity Linnæus candidly confesses his ignorance, and to which no botanist has yet found an ally). Next follow *Rumex*, *Rheum*, *Polygonum*, &c. The sixth section has *Nyssa*, *Mimusops*, *Rhizophora*, *Bucida* and *Anacardium*; and the seventh *Laurus*, *Winterana* and *Heisteria*; in both which the fleshy receptacle appears, where he could trace it, to have guided Linnæus to an arrangement evidently paradoxical, which he labours, without satisfying us, to justify.

Order 13. **SUCCULENTÆ**. "Bradley wrote on Succulent Plants, by which he meant such as could not be preserved in a *Hortus Siccus*. When gathered, vegetables of this nature will live, often for a whole year, flowering as they hang up in a house, and throwing out roots afterwards if planted. All such plants, however, do not enter into the present order. *Stapelia*, *Euphorbia*, and *Aloe* are excluded. The *Succulentæ* grow, and become very turgid, in the driest soil, nor are any found in watery places. If moistened too much they perish, and their roots decay. They afford, in putrefying, a fine vegetable mould, whereas dry plants, like heath and fir, scarcely yield any."

Linnæus has distinguished these into four sections. In the first are *Cactus*, *Mesembryanthemum*, *Tamarix*, and others. *Nymphaea* placed here, in the Linnæan manuscript, as well as in Giseke's publication, was afterwards removed by Linnæus to his *Rhocadææ*. *Sarracenia* he conceived to be akin thereto. In his second section are *Sedum* and its numerous allies; in the third *Portulaca*, *Claytonia*, &c.; and in the fourth a very different assemblage, as we should think, composed of *Saxifraga*, *Adoxa*, &c. and even *Hydrangea*. Linnæus however thought all these sections nearly related. "They are," says he, "succulent, insipid, inert, and inodorous, therefore mere pot-herbs, widely different from the other fleshy plants, *Stapelia*, &c. whose fructification is so unlike them, and whose qualities are so poisonous. We find in this order, that opposite or alternate leaves is an indifferent circumstance. These plants have no true spines, no tendrils, nor climbing stems, neither stipules nor bractææ." (Giseke well remarks, that *Sedum acre* is one exception to their alleged insipidity, though we can scarcely agree with him that *Sempervivum sectorum* is another.)

Order 14. **GRUINALES**. The best known genera here are *Linum*, *Drosera*, *Oxalis*, *Geranium* and its relations. Linnæus admits also *Quassia*, *Zygophyllum*, *Averrhoa*, &c., and his editor inserts, with well-founded doubt, *Sparmannia*. Their roots and habits are various. Calyx usually of five leaves, and corolla of five petals. Stamens various in number and connexion. Pistils mostly five or ten. Fruits various. Linnæus professed himself unable to define the character of this order. Many of the plants have acid leaves.

Order 15. **INUNDATÆ**. "So called because they grow in water, many of them under its surface, except their blossoms." *Potamogeton* is the genus most generally known, to which Linnæus suspected *Orontium* to be related, but not correctly. *Myriophyllum*, *Proserpinaca*, *Hippuris*, &c. are placed here, and even *Elatine*, notwithstanding its numerous seeds. *Chara* and *Najas* form a section at the end. *Callitriche*, *Lemna*, and even *Pistia*, were proposed to be brought hither; with *Saururus* and *Aponogeton*.

"The qualities of the *Inundatæ* are very obscure. These plants are mostly inodorous, except a fishy scent in some; nor have they any particular taste; hence they are not used medicinally."

This order is out of its place with respect to the arrangement by the cotyledons, of which Linnæus seems aware, from the remarks subjoined to it, in his lectures, concerning that principle. To these we shall hereafter refer.

Order 16. **CALYCIFLORÆ**. This consists of *Oryris*, *Trophis*, *Hippophææ* and *Elæagnus*. No observation relative to it is given in the lectures, except that these genera are removed elsewhere. A manuscript note before us indicates a suspicion of its relationship to the 6th section of the *Holeracææ*. Linnæus sometimes referred *Memecylon* to one of these orders, sometimes to the other, but finally to his 18th; we should rather presume it belongs to the 19th notwithstanding the definite number of the stamens, which caused Jussieu to range this genus with the Linnæan *Calycanthemææ*; see the next order.

Order 17. **CALYCANTHEMÆ**. "The title of this order is precisely synonymous with the last, and is applicable in a different manner to the different genera of which the present consists. In those whose germen is inferior, the calyx bears the flower and enfolds the germen; in those where the latter is superior, it is unconnected with the calyx, into which the stamens are, in that case, inserted, like the *Sciticosæ* and *Pomacææ*, not into the receptacle. The germen is inferior in *Epilobium*, *Oenothera*, *Gaura*, *Jussiaea*, *Ludwigia* and *Isnarda*, as well as in *Mentzelia* and *Loosa* (or *Loasa*); "in the rest, *Ammannia*, *Grislæa*, *Glaur*, *Peplis*, *Frankenia*, *Lythrum*, *Melastoma*, *Osbeckia* and *Rhexia*, it is superior. Some genera have four, others five or six petals. *Glaur* and *Isnarda* have none. *Ammannia* and *Peplis* have occasionally petals, or not, in the same plant. *Melastoma* has a berry; the rest a capsule, usually of four or five cells, in some genera of but two, or one." Linnæus mentions *Melastoma* as the only arboreous genus. The rest are herbaceous, (rarely shrubby), with opposite or alternate leaves;

Botany.

stamens from four to twelve, pistil always solitary, the stigmas either four or one.

“ These plants are mostly inodorous and insipid, except a styptic property in the root of *Lythrum*; none of them are used in the shops. It is remarkable in this order particularly, that some flowers are sessile and axillary, but towards the summit the leaves gradually diminish, and are finally obliterated, so that the inflorescence becomes a spike, as may be seen in *Epilobium*.”

Order 18. BICORNES. “ So called,” by Linnæus, “ from the anthers, which in many of this tribe terminate in two beaks. The plants are rigid, hard and evergreen, almost all more or less shrubby; certainly perennial. *Diospyros* is arboreous. The leaves of this order are alternate, simple, undivided, scarcely crenate, permanent. Stipulas and bractees wanting;” (certainly not always the latter). “ Calyx of one leaf, more or less deeply four or five cleft. Corolla usually monopetalous; in *Pyrola*, *Clethra*, and their near allies, pentapetalous. Nectaries none, except in *Kalmia*.” (Linnæus can here mean only the pouches which for a while detain the elastic stamens, and those are by no means nectaries.) “ Stamens from four to ten, answering to the divisions of the corolla, or twice their number. Pistil 1, except *Royena*, which is digynous. Germen in some superior; in others, as *Vaccinium*, inferior. Some have a capsule, others a berry; the cells of each four or five; but *Diospyros* has a fruit of eight cells. The seeds are either one or many in each cell, mostly small, chaffy.” Linnæus remarks that “ they can scarcely be raised in a garden, especially as the plants are many of them natives of boggy situations;” but our English gardeners are masters of their treatment, witness the abundance of *Ericæ* from the Cape, now common in every greenhouse, and many other charming shrubs, cultivated in a peat soil. He conceived the whole order to be nearly confined to one meridian, from the North Cape of Lapland, to the Cape of Good Hope; but he is incorrect in saying, there are very few in North America, and none in the East or West Indies.

Halesia, *Styrax*, *Spathelia*, *Citrus* and *Garcinia* are subjoined as an appendix to the *Bicornes*, but there is allowed to be a considerable distance between them, and the last is erased in the *Gen. Plant.* as having opposite leaves. Giseke records, p. 345, that when Linnæus said no *Erica* grew in America, he asked him whether *Hudsonia* were not an exception to this? On which he took that genus from his herbarium, and after contemplating and replacing it, wrote something, Giseke knew not what, in his *Genera Plantarum*. We find what he wrote to be as follows: “ Videnda *Hudsonia*, *Empetrum*, *Ilex*, *Itea*.” It is interesting to be thus able to trace the thoughts of such a man. He was moreover correct as to the genus *Erica* itself, of which no species has been detected in America.

Order 19. HESPERIDÆ. Of this nothing is said in the lectures. The original genera are *Eugenia*, *Psidium*, *Myrtus*, and *Caryophyllus*; to which Giseke has added *Calyptanthus* and *Legnotis* of Swartz. *Melaleuca* also strictly belongs to this tribe; though, by a strange error, referred in the *Mantissa* to the

VOL. II. PART II.

Botany.

40th order, and yet said to be akin in *Ginora*, which belongs either to this or the 17th. *Philadelphus* is subjoined as forming a section by itself, and still with a mark of doubt. The discoveries in New Holland have thrown much light on this fine order of aromatic and elegant shrubs, of which the Myrtle is a familiar type. Linnæus intended to remove *Garcinia* hither.

Order 20. ROTACÆ. The lectures are also deficient as to this order. It consists of *Trientalis*, *Centunculus*, *Anagallis*, *Lysimachia*, *Phlox*, *Exacum*, *Chlora*, *Gentiana*, *Swertia*, *Chironia* and *Sarothra*; to which *Ascyrum*, *Hypericum* and *Cistus* stand as an appendix. The wheel-shaped corolla of many of the above plants, has evidently suggested the name.

Order 21. PRÆCIÆ. *Primula* and its elegant relatives form the basis of this order. “ They are all destitute of stems. Leaves simple. Flowerstalk umbellate, except in *Cyclamen*. Flower regular. Calyx, as well as corolla, five-cleft. Stamens five. Style one. Fruit a simple superior capsule. The umbel is often accompanied by an involucre. They are vernal-flowering plants, and have, except *Cyclamen*, nothing malignant in their qualities.” *Limosella* stands alone in a second section of this order, but rather perhaps belongs to the 40th. *Menyanthes*, *Hottonia* and *Samolus* form a third section, attended by a mark of doubt. *Sibthorpia* was once inserted in manuscript, but afterwards erased.

Order 22. CARYOPHYLLÆI. The Pink and Campion tribe. “ Root fibrous. Stem herbaceous, scarcely shrubby, jointed; its branches commonly alternate. Leaves simple, more or less of a lanceolate figure, undivided, hardly crenate in any degree, sessile, with no other appearance of a footstalk than their elongated narrow base, opposite, obvolute. Stipulas none; neither are there any distinct bractees, nor spines, prickles nor tendrils. The plants are mostly smooth, few are hairy, none prickly or bristly. Flower rarely sessile. Stamens never numerous, but either the same in number as the petals, or twice as many. Pistils from one to five, not more. Fruit a capsule, either of one cell, or of as many as there are styles; the cells usually with many seeds, *Drypis* only having a solitary seed. A few of these plants with separated flowers occur among the species of *Cucubalus*, *Silene* and *Lychnis*. The whole order is harmless, without any peculiar taste or smell, except in the flowers. It contains the *flores caryophyllati* of Tournefort, who defined these as having the calyx tubular, and the limb of the corolla flat; but he referred *Statice* and *Linum* hither, which differ widely from this order, while his character excludes the *Alsine*, or Chickweed, tribe.” Linnæus thought *Velexia* had been wrongly placed here by Gerard, and was doubtful respecting *Cherleria*; but he was afterwards satisfied that both are *Caryophyllæi*. He remarks that “ the order consists, as it were, of two leading genera, or rather families, the *Caryophyllus*, or Pink tribe, such as *Dianthus*, *Saponaria*, *Gypsophila*, *Silene*, *Lychnis*, &c.; and the *Alsine*, or Chickweed family, consisting of *Spergula*, *Cerastium*, *Arenaria*, *Stellaria*, and others. In the first division, the calyx is tubular, of one leaf; in the second of five.” A third section of this order has *Pharnaceum*,

3 E

Botany. *Glinus*, *Mollugo*, *Polycarpon*, *Minuartia*, *Queria*, *Ortega*, *Loeflingia*; to which were afterwards added *Gisekia* and *Rotala*. *Holosteum* also, having lacinated stipulaceous membranes, was intended to have been removed to this third section. *Scleranthus*, by itself, makes a fourth, but is erased by Linnæus, and removed to his 31st order. *Polypremum*, with a query, stands at the end.

A most extraordinary remark is subjoined by Professor Giseke at p. 354; that "*Alsine media* and *Holosteum umbellatum* are one and the same plant," and that "Linnæus had no specimen of the former in his herbarium in the year 1771." Swartz is cited in confirmation, who only says in his *Obs. Bot.* 118, that this *Alsine* is a species of *Holosteum*. We trust it is better referred to *Stellaria* in *Flo. Brit.*, and we can affirm that an authentic specimen of this common plant, which Linnæus had when he published the first edition of *Sp. Pl.*, in 1753, still exists in his collection. The real *Holosteum umbellatum*, a rare English plant, is well delineated in *Engl. Bot.* t. 27.

Order 23. TRIHILATÆ. "So called from its three-celled, and three-grained fruit, for all the cells are distinct. *Melia* however has five cells. The calyx in this order is either of four or five leaves, or of one leaf in five deep segments. Petals four or five. Stamens eight or ten. Pistil one. One part of the fructification is often diminished as to number, for instance the petals; and when they become but four, the stamens are only eight. A nectary is always present; hence the corolla is frequently irregular. The leaves are disposed to be compound, and are both opposite and alternate. The whole order scarcely contains any thing acrid, except *Tropæolum*, nor any thing either fragrant or noxious; on the other hand, the *Tricocca*, properly so called, are highly poisonous."

The first section consists of *Melia*, *Trichilia*, *Guaiea* and *Turraea*; to which Linnæus has added, from his 54th or miscellaneous order, *Cedrela* and *Swietenia*. The second is composed of *Malpighia*, *Banisteria*, *Hirca*, *Triopteris*, *Acer* and *Aesculus*. Linnæus was inclined to bring hither, from his 14th order, the genus *Fagonia*, because of the likeness of its flower to *Malpighia*, but he found a difficulty in the five cells of its fruit. A third section consists of *Staphylea*, *Sapindus*, *Paulinia*, *Cardiospermum* and *Tropæolum*; to which *Hippocratea* is added in manuscript, and a question subjoined, Whether *Staphylea* be not akin to *Celastrus*? Cavanilles has added many new genera to this order, but he is surely complimented to excess by the editor of the *Prælectiones*.

Order 24. CORYDALES. "The title of this order is synonymous with *Fumaria* amongst ancient writers."

"The genera are *Melianthus*, *Monnieria*, *Epimedium*, *Hypecoum*, *Fumaria*, *Leontice*, *Impatiens*, *Utricularia*, *Pinguicula*, and perhaps *Calceolaria*. The calyx is of two leaves; except in *Pinguicula*, where it is only cloven; and *Melianthus*, where it consists of four leaves. The flower of *Fumaria* is remarkable in its throat, and uniform in that respect throughout the genus, but the various species differ

widely in their fruit; which in some, as *officinalis*, &c. contains a solitary seed; in *capnoides*, *claviculata*, &c. it is a genuine pod; in *vesicaria* a large inflated capsule." *Monnieria* and *Melianthus*, (two very puzzling genera), were thought by Linnæus to be nearly related to each other, though differing from the order under consideration, in having several capsules, and a calyx in five deep divisions. But he judged the ringent corolla of *Monnieria* to betray an affinity to *Fumaria*; while the nectary of *Melianthus* is similar to that of *Monnieria*, the combined stamens of the latter being exactly those of *Fumaria*. Hence a relationship is traced between *Melianthus* and this order, which, but for *Monnieria*, could not have been suspected.

"There is a certain fragility and delicacy of texture characteristic of the *Corydales*, with a glaucous hue, which points out their affinity; as well as a bitter flavour. Scarcely any of the order are odiferous, except *Melianthus*, which is extremely foetid."

Linnæus professes his inability to point out any exclusive mark of distinction for this order. "The leaves indeed are alternate in all, *Calceolaria* excepted; and many bear stipulas. Their mode of flowering is spiked, racemose, or solitary, their stalk naked or leafy, different in different species. All that we are acquainted with are smooth and unarmed; a very few of them climbing by means of tendrils. *Melianthus* and *Monnieria* only are shrubby. All the tribe prefer shady, moist situations, where the soil is not disturbed." (Some however grow in cultivated ground, as the *Fumitoria*.)

"The *Melianthus*, a Cape plant, produces more honey than any other plant, so that a tea-spoon full may be collected every morning, from each of its numerous flowers. But the offensive odour" (of the bruised plant) "indicates a poisonous quality, as in *Cimicifuga*."

Order 25. PUTAMINÆ. On this order, named from the strong rind of the fruit in several instances, there is no commentary in the *Prælectiones*, nor any manuscript note in the *Gen. Pl.* The genera are *Cleome*, *Cratæva*, *Morisona*, *Capparis*; *Crescentia* and *Marcgravia* being added with hesitation. *Tanacetium* of Swartz, and *Possira* of Aublet, which last is *Rittera* of Schreber, are subjoined by Giseke.

Order 26. MULTISILIQUÆ. This consists of four sections. In the first are *Pæonia*, *Aquilegia*, *Aconitum* and *Delphinium*, to which Linnæus, alter much diversity of opinion, finally determined to add *Cimicifuga* and *Actæa*. The second contains *Dictamnus*, *Ruta* and *Peganum*; the third *Nigella*, *Garidella*, *Isopyrum*, *Trollius*, *Helleborus*, *Caltha*, *Ranunculus*, *Myosurus* and *Adonis*; and the fourth *Anemone*, *Atragene*, *Clematis*, and *Thalictrum*. "Most of the order, with a few exceptions, are of European growth; rarely arboreous or shrubby, except such species of *Clematis* as climb trees. The roots are fibrous, sometimes tuberous. Leaves often many-cleft, or compound; but in a few instances simple; all alternate, except in *Clematis integrifolia*. There are no stipulas, spines, nor prickles. One or two kinds of *Clematis* bear tendrils. Flowers in no case monopetalous. Stamens always more than eight, except in the second section. Fruit in some capsu-

Botany. lar, in some single-seeded. An acrid taste prevails through the whole. Their odour is disagreeable, almost universally, so that none is esculent, and many, if not all, are poisonous, though there is no milky plant among the whole, nor any one with a twining stem." Linnæus remarks, that "a calyx is very rarely present, and when it occurs, manifestly originates from the leaves;" but this is not applicable to *Ranunculus* and its nearest relations, nor to any genus in the second section; that section indeed being a most distinct order of itself, called by Jussieu *Rutaceæ*, but not well defined by him.

Order 27. RHÆADEÆ. The Poppy tribe. No remark on this order is found in the lectures of Linnæus, but he has made some manuscript notes. He wished to remove it next to the 24th and to place its genera thus, *Argemone*, *Chelidonium*, *Papaver*, *Podophyllum*, *Sanguinaria* and *Bocconia*. *Sanguinaria*, he observes, has the flower of *Actæa*, which last genus he had once brought hither. He has finally placed here *Aristolochia*, *Asarum* and *Cytinus*, as we have mentioned under the 11th order. *Nymphaea* also is indicated, but afterwards erased, which is unfortunate.

Order 28. LURIDÆ. The gloomy family of night-shades, henbane and tobacco. "This order is a most distinct and evident one. All the plants have alternate leaves; a five-cleft calyx; monopetalous corolla; stamens four or five; pistil one; germen superior; seed-vessel of two cells, in some a berry, others a capsule. Their corolla folds in a plaited manner."

Digitalis, *Celsia*, *Verbascum*, *Nicotiana*, *Atropa*, *Hyoscyamus*, *Datura*, *Physalis*, *Solanum*, *Capsicum*, are examples of this order. "They are none of them arboreous, though some are shrubby. Colour (of the herbage) mostly dull and lurid; the taste disagreeable, smell nauseous; hurtful to the nerves, hence their generally poisonous qualities." *Ellisia* is properly expunged in the manuscript, and *Nolana* with equal propriety removed hither from the 41st order.

Linnæus observes, that "the poisonous quality of *Verbascum* appears in its power of killing fish, if made up into balls with meal." "*Nicotiana rustica*," he says, "furnishes the Turks with their best tobacco, yet it is not cultivated by us, though it grows readily. *Atropa Mandragora*, a most poisonous and dangerous plant, becomes, under proper management an excellent and powerful medicine," for instances of which Linnæus referred his hearers to his lectures on the *Materia Medica*. These, as Giseke notices, were never published. On turning to the manuscripts used by the professor in that course, we find the *Mandragora* mentioned as "vireose, acrid, bitterish and nauseous, useful in the gout and colic; the herb boiled in milk, and applied to scirrhus tumours, more active in dispersing them than hemlock or tobacco. Three of the berries boiled in milk, given to a potter, labouring under a dreadful cholick, threw him into a sleep for twenty-four hours, out of which he awoke cured. The ancients gave an infusion of this plant in wine, before they amputated a limb. Its narcotic qualities render it very useful in epilepsy and hysteria, though

to be cautiously administered. Nothing can be more dangerous in a state of pregnancy. The editor of Hernandez, *Hist. Nat. Mexic.* Book viii. chapter 28, speaks of this fruit as eatable, without any soporific or injurious effect."

Linnæus himself appears to have been doubtful about *Catesbæa*, which he has marked as akin to his *Dumosæ*. Giseke has subjoined an observation, not well founded, of the *Solandra* of Swartz being hardly distinct from *Datura*.

Order 29. CAMPANACEÆ. These Linnæus has noted as most nearly allied to the 24th order. "They never form trees, rarely shrubs. Leaves in every instance alternate; calyx and corolla five cleft; stamens five; pistil one, except *Evolvulus*, which has at least a deeply four-cleft style, if not four distinct ones. Fruit a capsule. They are milky plants, at least while young and tender. Their qualities therefore are purgative, and but slightly poisonous."

Convolvulus and *Campanula*, with their respective allies, constitute this order. To the latter, *Viola* is supposed to be connected, through the medium of *Lobelia*. *Parnassia*, though in the manuscript rightly said to be not milky, stands at the end, its affinity being indicated by the nature of the flower-stalk, calyx, as well as the seeds and their situation, but especially the nectaries and stigma. The anthers come one after another and impregnate the latter, retiring subsequently in their turns. Their close application to that part, as Linnæus conceived, rendered the access of extraneous pollen impossible, "hence" says he "no more species of this genus can be produced." This alludes to his hypothesis of new and permanent species, or even genera, having been generated, from time to time, in the vegetable kingdom, by cross impregnation; which we are very unwilling to admit, nor do any of his instances prove satisfactory to us. As to *Parnassia*, we now know several American species, as distinct as those of any other genus.

Order 30. CONTORTÆ. "This order derives its name from the corolla, which," (in all the species known to Linnæus,) "is twisted in the bud, contrary to the course of the sun, its limb being wheel-shaped, when expanded, in such a way that each of its segments, unequally proportioned in their margins, is curved inward under the next segment, the shorter side of the former being beneath the longer one of the latter. Europe is very poor in this tribe, India very abundant. Many of the plants are milky, and, like most other such, poisonous; some indeed so violently, as immediately to destroy animals that eat them. Their medical effects, rightly managed, may be very great. They have all, naturally, an injurious property, even *Asclepias Vincetoxicum*, though this plant, like *Nerium* and *Vinca*, is scarcely milky, but in its very youngest shoots." (It is singularly remarkable that the fruit of one of this family, at Sierra Leone, the size of an orange, yields a copious and wholesome milk, used by the colonists as cream to their tea. See *Sm. Introd. to Botany*, ed. 3. 316.)

"Many of the order of which we are treating are shrubby; the leaves opposite and evergreen, except the species of cold countries. The flower is, in many cases, intricate in structure, because of the

Botany. peculiar apparatus of the nectaries of various genera."

"The roots are perennial. Leaves all, as far as hitherto known, simple and undivided, and, with very few exceptions, opposite; sometimes ternate, or quaternate; rarely alternate. The inflorescence is often peculiar, in having its flowerstalk not axillary, but proceeding from the side of the stem between the insertion of the leaves. Calyx of one leaf, five-cleft. Corolla of one petal, regular, its segments contorted, as above described, and often notched in the margin. Nectaries, in many instances, singularly formed. Stamens five. Pistils two, or one with a double stigma. Germen superior in all, except *Gardenia*, *Genipa*, and *Macrocne-mum*," (all now certainly not admitted into this order.) "The Fruit, in many genera, as *Vinca*, *Nerium*, *Echites*, *Plumeria*, *Tabernaemontana*, *Cameraria*, *Periploca*, *Apocynum*, *Cynanchum*, *Asclepias*, *Stapelia*, *Ceropegia* and *Pergularia*, consists of two distinct follicles, not observable in other plants. This sort of seed-vessel is like a *spatha* amongst the other kinds of calyx, of one valve, splitting longitudinally at the inner edge. But the seeds are not attached to the suture, there being a separate thread-shaped receptacle, extending the whole length of the seed-vessel, over the whole of which the seeds are imbricated, in a downward position. In all the above mentioned the seeds are crowned with a soft hairy tuft, except those of *Vinca*, which have no such appendage. The flowers of the *Contortæ* are usually very handsome, and there is something so singular in the structure of many of them, especially relative to the nectary and stigma, that it is difficult to say, in many instances, whether they have one or two stigmas; especially when two germens seem to bear but a single style. The corolla in all is five-cleft, and the stamens five. Jacquin contends that the latter are really ten. Linnæus from repeated examination of *Asclepias*, was confirmed in the former opinion, and especially from the investigation of *Periploca*, whose flower, evidently constructed on the same principle as *Asclepias*, has, no less evidently, but five stamens."

Giseke very improperly annexes *Embothrium* and *Rhopala* to this order, only because their fruit is a follicle; nor does any other genus which he, or Linnæus, has mentioned, really belong to it, except *Alamanda*, *Rauwolfia* and *Cerbera* of the latter; *Gynopogon* and *Melodinus* of Forster, with *Willughbeia* of Schreber. The first has a bivalve coriaceous capsule, as if formed of two follicles united, with imbricated seeds; the rest have pulpy fruits. Most of the other genera referred hither, as *Gardenia*, *Cinchona*, *Portlandia*, &c. belong to the great order of *Rubiaceæ* in Jussieu, of which the Linnæan *Stellateæ*, No. 47, make a part. It must be allowed, nevertheless, that the corolla of *Gardenia* answers to the character of the *Contortæ*. Mr R. Brown, in the *Wernerian Transactions*, has thrown much light on the principal genera of this family, under the title of *Asclepiadeæ* and *Apocineæ*, with the addition of numerous new ones.

Order 31. VAPRECVLÆ. No explanation of this occurs in the *Prælectiones*. The genera are *Dais*,

Botany. *Quisqualis*, *Dirca*, *Daphne*, *Gnidia*, *Struthiola*, *Lachnæa*, *Passerina*, *Stellera*, with *Thesium*, and in the manuscript *Scleranthus* and *Santalum*. These three last do not properly belong to the others, which constitute a most natural order of generally small shrubs, as the name implies. They are known by their tough branches; silky inner bark; simple entire leaves; acrid and even burning flavour; and sweet-scented flowers, whose calyx and corolla are united into one integument, most coloured within.

Order 32. PAPILIONACEÆ. An extensive and very natural family, "consisting of the *Leguminosæ* of Ray; which Tournefort," (following an idea of Baptista Porta), "called *Papilionaceæ*; Rivinus *flores tetrapetalis irregulares*; and Magnol *pentapetalis*. They have not all five petals, for in many the claw of their keel is simple; in some the keel is separated towards the base into a double claw; while in a few only, the whole keel is composed of two distinct petals, as in *Spartium*."

"Their character is as follows. Perianth of one leaf, irregular, inferior, generally withering. Corolla nearly the same in all. Its standard either emarginate or entire, either reflexed or not at the sides, for the most part very large, compared with the other petals. Wings, if present, always two, opposite, frequently large, sometimes, as in *Colutea* and *Hedysarum*, very short. Keel simple, either pointed, obtuse, or abrupt. Stamens ten, nine of which have their filaments united, more than half way up, forming a membranous sheath to the pistil; the tenth sticking closely under the pistil, and being sometimes inserted into the base of the tube composed by the other nine. Hence arise two divisions of the order, without attention to which the genera are with difficulty defined. Pistil generally uniform; the style downy or woolly, either above or below; stigma either acute or capitate. Legume of two valves, which must not be confounded with a *Siliqua*, or Pod, though old writers have so termed it, applying that name equally to the fruit of this order and that of the *Tetradynamia* class. As these fruits differ widely in structure, Linnæus has restricted to the latter the term pod, whose character is to have the seeds attached to each suture of the valves; whereas in the legume, or fruit of the class *Diadelphica*, they are connected with one suture, or margin, only. The name of *legumen* indeed originally belonged to the seed itself of these plants; but for want of a better word, Linnæus has applied it to their seed-vessel. The legume is mostly of one cell, containing many seeds; except *Astragalus* and *Biserrula*, in which one suture is internally dilated, as it were, so as to make a partition, separating the fruit into two cells; whilst *Phaca* has the same part extended only half the breadth of the legume, rendering the separation incomplete. *Geoffræa* has a *drupa*, which still ought to be considered as a single-seeded legume, whose pulp is hardened," (or rather, whose coat is made pulpy.) "The ripe legume bursts along its sutures, and throws out its seeds. There are indeed some which do not open in this manner, but fall off in separate joints, each containing a seed, examples of which are *Hedysarum* and *Ornithopus*."

Botany.

"The genera of this natural order so nearly approach each other, that it is difficult to detect their discriminative characters. Tournefort, though he distributed other genera by their flowers, divided and determined these by their foliage. But *Hedysarum* forms an objection to such a principle of arrangement, because some of its species have simple leaves, others ternate, conjugate, or pinnate."

"*Lathyrus*, *Cicer*, and *Vicia* are genera most nearly akin to each other, as are *Phaseolus* and *Dolichos*. *Coronilla*, *Ornithopus*, *Hippocrepis*, *Scorpiurus*, *Lotus*, and some species of *Trifolium*, agree in their umbellate inflorescence." (*Sophora*, and its many new-discovered allies, ought to make a section, at least, by themselves.)

"There is no poisonous plant in this whole order, except the seeds of *Lupinus*, with which the *Hippopotamus* is killed, and which fowls will not eat. Indigo becomes poisonous in its preparation, but the plant is originally harmless. On the other hand, none of this tribe is medicinal, except *Glycyrrhiza*. *Galega*, commended as antipestilential, is not to be trusted. These plants have no remarkable odour," (except in the flowers of a few species.) "Their seeds are flatulent; but afford nourishing food for labouring people."

Order 33. LOMENTACEÆ. "These are perhaps all shrubby," (or arboreous.) "Leaves alternate, compound, at least in the indubitable plants of this order; pinnate or bipinnate; without a terminal leaflet, *Moringa* excepted. Stipulas always large, particularly to be noticed. Calyx five-cleft. Corolla in some degree irregular, polypetalous, except *Ceratonia*, and several *Mimosæ*. Stamens differing in number; mostly ten. Pistil universally single. Fruit a legume, for the most part having transverse partitions. The leaves fold together at night, except those of *Ceratonia*, and that in a different manner according to the different species. Many of this order possess a purgative quality, while some have a virose or nauseous flavour about them, but this last is not at all the case with *Ceratonia*."

Of *Polygala*, which stands at the head of this order, nothing is recorded by Giseke from the lectures of Linnæus, nor has he himself made any note. It surely answers but indifferently to the *Lomentaceæ*. Genuine examples of the order are *Bauhinia*, *Hymenæa*, *Cæsalpinia*, *Cassia*, perhaps *Securidaca*; from which *Ceratonia*, *Mimosa*, *Gleditsia*, &c. considerably recede in character, though less in habit. *Cercis* ought to be ranged, with *Anagyris*, *Sophora*, &c. either in the preceding order, or rather in a separate one, intermediate between the two.

Order 34. CUCURBITACEÆ. "In this order there are, properly, no trees. Some of the plants indeed have a climbing, woody, perennial stem; others a perennial root only; whilst others again are entirely of annual duration. Leaves in all alternate, simple, always accompanied at their origin by stipulas. There are mostly glands, either on the foot-stalks, at the base of the leaf, or on its disk. All have tendrils, by which they climb if they have any opportunity; otherwise they are procumbent. These plants seem akin to the *Sarmentaceæ*, order 11th; but the latter have a twining stem, these not; they are

Botany.

monocotyledonous, these dicotyledonous; they are destitute of tendrils, with which these are furnished. The calyx is either of five leaves, or five deep segments. Corolla of one petal, in five deep divisions, but so much cut, in many instances, that it is scarcely possible, but from analogy, to say whether it consists of one or five petals. The stamens are inserted, not into the receptacle, but into the interior surface of the calyx, to which also the corolla is attached. Their filaments are often five, but frequently so combined as to appear three only. So also the anthers are often connected, the summit of one to the base of another, making a continued serpentine line. The style is of considerable thickness, with three, frequently cloven, stigmas. Fruit internally of three cells, fleshy, and somewhat juicy. The seeds are, for the most part, capable of being kept for a long time, though they appear of a dry nature; but that they are not really so, is evident from the emulsions prepared from some seeds of this tribe. Gardeners think them better for keeping. The sex of the flowers is, in several cases, distinct, and either monoecious or dioecious. The whole order is noxious and fetid, hence it affords some of the most violent medicines, as *Colocynth* and *Elaterium*. Even melons themselves, if taken too plentifully, are said to be injurious, though in ripening they part with much of their unwholesome quality." The genera are *Gronovia*, *Anguria*, *Elaterium*, *Sicyos*, *Melothria*, *Bryonia*, *Cucurbita*, *Cucumis*, *Trichosanthes*, *Momordica*, *Feuillea*, *Zannonia*, *Passiflora*. "The last affords some of the most beautiful of all flowers; many of them are fragrant."

Order 35. SENTICOSÆ. The briar and bramble tribe. The genera are *Alchemilla*, *Aphanes*, *Agri-monia*, *Dryas*, *Geum*, *Sibbaldia*, *Tormentilla*, *Potentilla*, *Comarum*, *Fragaria*, *Rubus*, *Rosa*. *Poterium* and *Sanguisorba* are inserted at the head of this list, in the Linnæan manuscript. See the following order.

Order 36. POMACEÆ. The apple and plum kinds, consisting, in the first section, of *Spiræa*, *Ribes*, *Sorbus*, *Cratægus*, *Mespilus*, *Pyrus*; in a second, of *Punica*; and, in a third, of *Chrysobalarus*, *Prunus* and *Amygdalus*. These two orders are treated of together, in the *Prælectiones*, it is not said for what reason, though their strict affinity cannot be overlooked. "Many of these plants," says Linnæus, "are shrubs, most of the whole are perennial, very few annual. They are rarely smooth. The leaves are alternate, mostly compound. Stipulas always two, large. None of the plants properly climb, though some brambles support themselves on their neighbours. Their distinguishing character principally consists in the receptacle of the stamens being equally that of the germen, but raised, at the sides of the calyx, above the germen. Hence, the calyx bearing the stamens, they are *calycanthemi*. The fruit is either superior or inferior, therefore that distinction is not always important. In *Rosa*, for instance, the part in question seems inferior, but is in fact the contrary, for the seeds are really inserted into the inner side of the calyx, exactly as in *Mespilus*, with this difference only, that in the latter they are imbedded in the pulp, which fills the calyx. The

Botany. segments of the calyx are mostly in a double series, the innermost largest, the outer alternate therewith, and smaller, answering to the petals. Stamens for the most part numerous, but *Sibbaldia*, *Alchemilla*, and *Aphanes* form an exception, the first having five stamens, the two last only four," (or even fewer). "The pistils vary in number. There is nothing acrid in the whole order, nor much fragrance; there is much of a styptic, little of a mucilaginous quality; nothing poisonous; so that if the fruits are worth tasting, they may certainly be eaten with impunity."

Order 37. COLUMNIFERÆ. "So called, not because the author meant to express, in the name, the essential character, but in allusion to some distinguished examples of this order, whose stamens are united into a columnar form. Linnæus was really the founder of the order in question, though Tournefort endeavoured to keep together as many of the same plants as possible, under his *Monopetali Campaniformes*. But the corolla has five petals, though they all fall off in one body, being connected with the combined stamens. Some have been denominated *akin to Malvaceæ*; indeed many of the class *Monadelphica* belong to this tribe."

"The root in all these plants is fibrous, in no instance bulbous or tuberous. Stem often herbaceous, but there are many arboreous, and amongst others the kinds of *Bombax*, or Silk Cotton, almost the largest trees in the world. Some of these only bear spines; but some species of *Hibiscus* are prickly. There is scarcely a perfectly smooth plant in the whole order. They have all stipulas, in pairs. The leaves are alternate, never opposite; in numerous instances stalked; plaited in the bud; and, what is remarkable, many of them have glandular pores under the rib. No tendrils are found in the order. The inflorescence is various. Calyx in several simple and five-cleft, but in some genera double, as *Malva*, *Alcea*, *Althæa*, *Lavatera*, *Malope*, *Gossypium* and *Hibiscus*. Petals generally five, but as they often adhere to the united filaments, the corolla seems monopetalous. This adhesion contradicts the opinion of Vaillant, who has said that stamens are never inserted but into a monopetalous corolla. Their connected claws often form a nectary between them. The corolla is somewhat abrupt, and twisted contrary to the sun's motion. Pistils usually corresponding in number to the parts of the fruit; as do the stigmas, where the style is simple. *Turnera* has as many styles, as there are cells in the capsule. The fruit is always superior, but differs in different genera. *Malva*, *Alcea*, *Althæa*, *Lavatera* and *Malope*, have numerous capsules, ranged like a wheel round the base of the style; nor is the latter placed upon, but in the midst of, them, as in the *Asperifolia*, order 41. Each capsule is single-seeded, and falls off with the seed; which is likewise the case in *Urena*; such seed-vessels might perhaps rather be named *arilli*, or tunics, as they burst at their inner side. Many of this order have solitary seeds in their cells, or capsules, like the above, and the genus *Ayenia*; but many others are polyspermous, as *Bombax*, *Hibiscus*, *Theobroma*, &c. A few of the genera produce woolly seeds, as *Bombax* and *Gos-*

Botany. *sypium*; in the place of which appendage, *Adansonia* has a mealy powder. Some bear a capsule of five cells, containing many seeds; which in *Hibiscus Malvaviscus*," (now constituting the genus *Achania*), "becomes pulpy. It is curious that *Hibiscus Moscheutos* bears its flowerstalk upon the footstalk, like *Turnera*; a rare circumstance in the whole vegetable kingdom."

"*Hermannia* has hooded petals, in a corolla twisted like that of *Malva*. They are auricled and dilated below, forming a nectary by their involution, as the true *Malvaceæ* do by the cohesion, or approximation, of their petals. The calyx is tumid. Capsule of five cells. All the species are shrubby. The flowers are so alike in all, as hardly to be distinguishable from one another; and hence perhaps it may be presumed, that the various species, all natives of the Cape of Good Hope, may in this, as well as other genera, have been produced from the hybrid impregnation of some original one. *H. pinnata* has the only compound leaves in this order." We must protest against this extensive speculation, of the production of permanent mule species, having seen many arise from such a cause, but none continue to propagate itself for any length of time. It is not the least curious particular, in the structure of the genus before us, that the flowers, which commonly grow together in pairs, have the corolla twisted in an opposite direction to each other.

The second section of this order, composed of *Camellia*, *Thea*, *Gordonia*, *Stuartia*, *Tilia* and *Kigalaria*, are at least nearly akin to the foregoing genera.

"This whole order contains no disagreeable or hurtful plants, nor are they esculent. None are fœtid, but some agreeably fragrant. Many of the flowers are beautiful. Their quality is generally mucilaginous, particularly *Althæa*, *Malva* and *Alcea*. The ancients made considerable use of Mallows in their food, but these plants are now out of use in that respect."

Order 38. TRICOCCÆ. "Botanists apply this term to plants whose fruit is, in a manner, composed of three nuts, combined together like that of *Thea*. In the order under consideration, the seed-vessel is generally a roundish three-cornered capsule, rounded on all sides, with single-seeded cells, which bursting elastically, with considerable force, scatter the seeds to a distance. It must be observed, however, that as in this order some genera, like *Mercurialis* and *Cliffortia*, are dicoccus" (having only two cells, or lobes), "so there are tricoccus plants" (as *Thea*, and many more,) "that do not belong to it."

"The plants of this order bear alternate, mostly simple, leaves, often furnished with glands. Many afford a most acrid milk; they are generally offensive, nauseous, purgative, or poisonous. The style is in several highly remarkable, being more or less deeply three-cleft, and each of its branches divided. The calyx, as well as corolla, have always something unusual in their conformation, or in their nectary; and many of the genera are monoecious or dioecious."

"*Euphorbia*, as a familiar and most distinct genus, may serve as a principal example. It is certainly no

Botany. less singular than extensive. The calyx of one inflated leaf has four or five marginal teeth, and terminates in as many abrupt coloured glands. The latter are remarkably situated on the teeth themselves; but these teeth seem, together with their glands, to be rudiments of petals. In *Euphorbia corollata* the glands are actual petals, as thin, expanded, and delicate, as those of Flax; but scarcely another instance is known, of petals originating in teeth of a calyx."

"*Plukenetia*, a very rare plant, has a four-cleft flower, and four-celled fruit, with a climbing stem."

There are numerous genera besides. *Rumphia* and *Trewia* are added to the list in the Linnæan manuscript.

Order 39. SILIQUOSÆ. "All botanists have acknowledged the common affinity of the genera constituting this order, and have denominated them *Siliquosæ* and *Siliculosæ*. Tournefort called them cruciform flowers; Linnæus, *Tetradynamia*. These plants have mostly inversely-heartshaped cotyledons, except some Cresses, in which those organs are three-cleft; the rest agree with the genus *Convolvulus*; so this character is no proof of affinity."

"The stems are herbaceous, except some species of *Alyssum*, and one *Vella*. There is no real tree among the whole. The roots are all fibrous, none bulbous or tuberous," (except perhaps *Dentaria*.) "Leaves universally alternate, without stipulas, tendrils, prickles, or venomous stings. Inflorescence usually a *corymbus*, which gradually elongates itself into a *racemus*, so that the flowers are corymbose, and fruit racemose. Calyx always of four leaves, deciduous, except in *Alyssum calycinum* and *Brassica Erucastrum*. Petals four, with claws; some species of *Lepidium* and *Cardamine* only having flat, or straight petals. The receptacle in most, but not in all, is furnished with glands. Stamens six, the two opposite ones shorter, or at least more spreading." (A very few species have only four or two stamens.) "Fruit commonly a pod, with two valves, two cells, and many seeds. A few genera have a solitary seed, either imbedded in pulp, as *Crambe*; or in a lamellated flat seed-vessel, as *Isatis*; or in an angular one, as *Bunias*."

"The plants of this order are distinguishable into *Siliquosæ* and *Siliculosæ*, the former having an oblong, the latter a rounded pod. But it being difficult to define the precise limits of each, Linnæus refers to the *Siliquosæ* such as have a stigma without a style, and to the *Siliculosæ* such as have a style to elevate the stigma, which character is conspicuous in every instance, except in *Draba*, where the style is but short."

"It is of importance to observe whether the calyx in the present order be closed or spreading; that is, whether the leaves composing that part be parallel, so that their sides touch each other, or horizontally distant."

"The nature of a *Siliqua*, or Pod, appears from what has been already mentioned. It differs from a Legume, in having the seeds attached to each suture, or margin."

"All these plants have a more or less acrid watery juice; hence their external application excites red-

Botany. ness in the skin, and their internal use irritates the finer fibres. Nature therefore is solicitous to expel them, and, in consequence of their watery nature, by the kidneys, hence they are all diuretic. Salt being of a corrosive quality, produces scurvy; but salt is secreted from the body by the promotion of urine, though it must first be dissolved in a watery menstruum; consequently the herbs in question rank among the chief antiscorbutics, especially watercresses and scurvy-grass. They ought never to be used in a dried state, as their acrimony and medical virtues are destroyed by drying. Boiling likewise is destructive of acrimony, especially in these plants; they ought therefore to be taken recent. Their diuretic powers render them eminently serviceable for evacuating water in the dropsy. Yet their use ought not to be too long continued, as their acrimony abrades the minuter fibres, rendering the vessels, and the intestines, in a manner, callous. This appears from the rigidity and torpidity of stomach induced by too much use of mustard."

"There is scarcely any thing odoriferous about these plants, except in their flowers. When they are bruised, indeed, something volatile ascends, of an acrid, rather than odorous nature, irritating the coats of the nerves, and inducing spasms, which do not originate in the medullary substance of the nervous system, but in its coats."

No alteration or addition respecting the genera of the *Tetradynamia* occurs in the Linnæan manuscript.

Order 40. PERSONATÆ. There is no commentary on this order in the lectures of Linnæus. Giseke has given a synoptical arrangement of the genera, according to the shape of the corolla, which is not in every part precisely correct. He justly expresses his doubts respecting *Melaleuca*, of which we have spoken under the 19th order; and he truly observes that there is no order in which so many genera are named after botanists as in the present.

The only manuscript additions or corrections, which occur in the *Genera Plantarum* of Linnæus, are the following: *Martynia*, *Craniolaria*, *Torenia*, and *Scrophularia* are pointed out as akin to *Pedali-um*, in order 28th; *Hyobanche*, *Lindernia*, *Pæderota*, *Manulea*, *Premna*, and *Calceolaria*, are inserted, with a question, certainly not well founded, whether the latter should not rather be referred to the 24th order. *Brunfelsia* also is placed among the *Personatæ*, at the suggestion of Van Royen.

Order 41. ASPERIFOLIÆ. "These plants were first collected into an order by Cæsalpinus, and received the above appellation from Ray, because of their generally harsh or rough habit. Their root is fibrous. Cotyledons two. Stem branched; the branches alternate and round. Leaves alternate, simple; neither divided nor compound, for the most part nearly entire, rough with rigid scattered hairs; convolute before they expand. Stipulas none; nor are there, except very rarely, any other *fulcra*, or appendages. Common flowerstalk having the flowers ranged along one side. Before flowering it is rolled spirally backwards, gradually expanding as the flowers are ready to open, and divided into two parts, each bearing the flowers on its back, in the

Botany. form of an unilateral spike. Calyx in five divisions. Corolla inferior, of one petal, regular except in *Echium*, five-cleft; its mouth either furnished with vaulted valves, or crowned with teeth, or naked. Stamens five, equal; in *Echium* only they are unequal. Fruit superior. Germens four, naked, except in *Cynoglossum*, *Tournefortia* and *Nolana*; inserted into the receptacle by their base; hence the lowest part of each seed is of a tapering form, as if artificially rounded. Pistil one. Style not standing upon the germens, but occupying the central space between them; often divided into two equal parts; not one longer than the other as in the class *Didynamia*. Seeds four, rarely combined into two; but it is singular that *Nolana* has five seeds." Linnæus has, as already mentioned, removed this genus to his *Luridæ*, order 28th.

"The *Asperifoliæ* are distributed according to the mouth, or throat, of their corolla, which is naked, or pervious, in *Echium*, *Pulmonaria*, *Lithospermum*, *Heliotropium*, *Cerinthæ*, and *Onosma*; toothed in *Symphytum* and *Borago*; closed with vaulted valves in *Cynoglossum*, *Asperugo*, *Anchusa*, *Lycopsis*, *Myosotis* and *Tournefortia*."

In the *Gen. Plant.* *Messerschmidia*, *Coldenia*, *Hydrophyllum*, and *Ellisia* are inserted in manuscript.

"All the *Asperifoliæ* are mucilaginous, and act only as such. The ancients selected their four cordial flowers out of this order, seeming not to have been aware that the motion of the heart depends upon the nerves, which therefore must be strengthened if the force of the heart is to be increased. This end however is not to be attained by either the flowers or the herbs of this tribe, which nevertheless have long been used for the purpose. The leaves may be eaten as food, by which their small medical use may be estimated. The root is perennial and mucilaginous;" (we would rather say "if perennial, is mucilaginous," which perhaps were the original words of the lecture.) "Among the whole, *Symphytum* abounds most with mucilage, equalling, in quantity as well as quality, the monadelphous plant *Althæa* in this respect. *Symphytum tuberosum* has been recommended in the gout. Possibly its mucilaginous quality may hinder the crystallization of the gouty matter. The root in almost all the *Asperifoliæ* is red, but for the most part externally only. The root of *Lithospermum tinctorium*, now *Anchusa tinctoria*, is used for its colouring properties. Of all plants; the herbs of this order yield the largest proportion of ashes. There is hardly an odoriferous, nor one fragrant, herb in the whole tribe; though *Cynoglossum* has a somewhat fœtid scent. Their taste is nothing, the great quantity of mucilage involving the stimulating particles. These herbs are esculent, especially when young and tender, although their rough surface renders them less agreeable to delicate palates. They generally grow in dry mountainous situations; and it is singular that in proportion as they are found nearer to water, they become smoother."

Order 42. VERTICILLATÆ. "Ray, in constructing his system, founded three classes, which all succeeding botanists hitherto have approved, the *Stellatæ*, *Asperifoliæ*, and *Verticillatæ*; but he was un-

able to give proper characters of the genera. Hermann subsequently, establishing a system upon the fruit, called the *Verticillatæ* of Ray *Gymnotraspermæ*, plants with four naked seeds, but he could not by this means distinguish them from the *Asperifoliæ*, which have the same character. The generality of *Asperifoliæ*, in fact, differ from the *Gymnotraspermæ*, in their corolla, which in the former is regular, in the latter irregular, though likewise monopetalous. But *Echium*, though it belongs to the *Asperifoliæ*, has still an irregular corolla. The *Asperifoliæ* have alternate leaves, the *Gymnotraspermæ* opposite ones. These classes might therefore be distinguished from each other, according to Hermann's method, were not *Echium* an obstacle. Linnæus, however, that he might avoid all confusion between the orders in question, has borrowed a character from the stamens, and has referred to his class *Didynamia* such plants as have two stamens longer, and two shorter. He has moreover divided that class into two orders, the first of which comprehends Hermann's *Gymnotraspermæ*, whose stamens easily distinguish them from the *Asperifoliæ*. But the consideration of the stamens has further obliged the author of the sexual system to refer certain genera, of the natural order under our present consideration, to his class *Dianthria*. These are *Verbena*, *Lycopus*, *Amethystea*, *Ziziphora*, *Cunila*, *Monarda*, *Rosmarinus*, *Salvia*, and *Collinsonia*; of which *Verbena* and *Collinsonia* perhaps ought rather to be placed in the other order of the *Didynamia*, called *Angiospermia*." This is correct with regard to *Verbena* only.

"The calyx of the *Verticillatæ* is of one leaf, inferior. Corolla of one petal, irregular, in most instances gaping, with two lips, the uppermost of which was called by Rivinus the *galea*, or helmet, the lowermost the *barba*, or beard. Stamens four, except in the several genera just mentioned, where they are only two, inflexed, ascending under the upper lip. Germens four, from between which the style arises, as in the *Asperifoliæ*, which is wavy, solitary, except in *Perilla*, where there are two, and bearing two acute stigmas. Seeds four, naked, *Prasium* excepted, whose seeds have a succulent skin, causing them to resemble berries. A berry, properly speaking, is a seed-vessel; but in *Rosa* it is the calyx, in *Fragaria* the receptacle, and in *Prasium* the skin of the seeds."

"Many of this order are humble shrubs, none are trees, most of them are annual or perennial herbs. The stem is generally square. Leaves in every instance opposite, simple, mostly undivided. None of the plants are furnished with tendrils, nor of a climbing nature. The scent of nearly all of them is highly fragrant, the odoriferous matter being contained in minute cells, which, when the leaves are held against the light, appear like numerous perforations."

"The flowers usually stand in whorls, encircling the stem as with a ring. When these whorls approach very closely together, the stems appear spiked, as in *Origanum*."

"This order is in the highest degree natural; whence arises great difficulty in determining the genera. Linnæus has derived a character from the

Botany- calyx, according to which the whole order is divided into two sections."

Botany-

"The first of these comprehends such as have a five-cleft calyx, that is, where all the teeth of this part are nearly of equal size and shape. The second consists of those with a two-lipped calyx, which is indeed five-cleft, but its two upper segments are, in a manner, united into one, which might almost be termed emarginate only; while between these two united segments and the remaining three, there is so deep a fissure, at each side, that the calyx is nearly divided into two parts, or lobes. Linnæus has bestowed great attention in searching for the essential characters of genera in this natural order, and has detected several, which are marked in the *Systema Vegetabilium* with a sign of exclamation."

Order 43. DUMOSÆ. "*Dumus* and *nemus* are synonymous, meaning a thicket; or wood consisting of shrubs, not of large trees. All the plants of this order are shrubby, but none of them, except in the genera of *Sideroxylum* and *Chrysophyllum*, grow to large trees."

"*Rhamnus* is supposed to be familiar to every body. Its calyx is tubular, five-cleft at the margin, occasionally coloured, like a corolla, but not perforated at the bottom. A monopetalous corolla falls off, with a perforated tube; which is not the case here. But betwixt every two segments of the calyx is stationed a delicate little scale, which any person might easily take for so many petals. The stamens however, being placed under each scale, are therefore alternate with the divisions of the calyx; whereas if these scales were real petals, the stamens ought, by a general rule, to be alternate with them, and not with the parts into which the calyx is divided. Some species, as the Buckthorn, *R. catharticus*, have four-cleft flowers, but they are mostly five-cleft. This last-mentioned, like *R. alpinus*, is dioecious; *Zizyphus* is polygamous. The stigma in some *Rhamni* is emarginate, in others three or four-cleft. The fruit of this genus is various; a berry in some with four seeds, in others, as *Paliurus* and *Alaternus*, with three; in others again it has a single seed with two cells, as in *Zizyphus*. *Paliurus* has not, properly, a berry, but a depressed, bordered, shield-like capsule. The stem in some is thorny, in others prickly, in others unarmed."

"French botanists have recommended the dividing of this genus into several, a measure which appears highly proper to those who have not seen the Indian species. If such genera are to be distinguished by their fruit, species most resembling each other will be put asunder, and widely different ones brought together, as any person making the experiment will find. Besides, the structure of the flower, and the habit of the plants, are respectively so alike in all the species in question, and so different from all the rest of the order, that any peasant might perceive their affinity."

"*Phytica* agrees in almost every point with *Rhamnus*, except that its flowers are aggregate, and florets superior. This genus is so nearly akin to *Brunia*, that without seeing the fruit, which very rarely occurs, they can scarcely be distinguished. *Phytica radiata* therefore, universally esteemed a *Phytica*,

proves, on the detection of its fruit, to be a *Brunia*."

"*Ceanothus*, with its three-lobed fruit, like that of *Rhamnus Alaternus*, agrees in every character with *Rhamnus*; but the scales of that genus are here drawn out into vaulted petals, supported by long claws."

"*Bistneria* differs in hardly any respect from *Rhamnus*, except its anthers; for the calyx, prickles, and every thing else, answer so well, that at first sight one would decidedly take it for a species thereof."

"*Sideroxylum* has a five-cleft calyx, and at the same time a monopetalous corolla; but between all the segments of the latter stands a little serrated tooth, analogous to the scales of *Rhamnus*. The flowers are likewise sessile on the stem, but the berry has only one seed."

"*Chrysophyllum* is so nearly akin, and so similar, to *Sideroxylum*, as hardly to be distinguishable by its general aspect; but its fruit contains many seeds, though indeed they are disposed in a circle."

"*Achras* differs from *Chrysophyllum* in having a six-cleft flower; and to this genus *Prinos* is very nearly related, differing in the flat-form of the corolla, and fewer cells of the fruit."

"*Ilex* so nearly accords with the last-mentioned genus, that the only *Prinos* then known was originally taken for an *Ilex*; but the flower of *Ilex* is four-cleft, not six-cleft."

"*Tomex* and *Callicarpa* only differ from *Ilex* in having a single style, and not four stigmas. The berry of *Callicarpa* is like that of *Ilex*. In *Tomex* the stamens are inserted into the receptacle, whereas in *Callicarpa* they are attached to the tube of the monopetalous corolla." These genera have since been united by the author himself.

"*Euonymus* is so nearly allied to *Tomex*, as scarcely to be distinguishable, except by having a capsule instead of a berry. Its seeds moreover have a pulpy tunic."

"*Celastrus*, though differing from *Euonymus* in having alternate leaves, is so much akin to that genus, as to have been called *Euonymus* by all systematic writers. Yet its fruit differs in number and proportion from *Euonymus*, just as *Peganum* does from *Ruta*. The tunic of the seeds however, though not pulpy, confirms the affinity to which we allude. Some botanists, especially the French, are unwilling to admit plants with opposite leaves and alternate ones into the same natural order, and they are right; yet this character is not absolute, for such a difference often occurs in one and the same genus."

"*Viburnum* and *Cassine* come so near together, that there is rather a question respecting the distinction of the genera themselves, than of their natural order. *Cassine* has three seeds, *Viburnum* one, which seems two combined. The former is akin to *Sambucus*, and, like that genus, emetic in quality. Concerning the affinity of *Viburnum* to *Ilex* and *Callicarpa*, any person, who considers their fructification and habit, can have no doubt. Thus far therefore the matter is clear."

"*Sambucus* may excite some mistrust, because of its inferior fruit; yet this is the case in *Phytica*,

Botany.

about which nobody has ever doubted. The leaves, aspect, and stipulas indeed seem to indicate something extraneous, and leave us in uncertainty."

"So *Rhus* has much the same sort of fructification, and a berry with one seed; as well as the closest affinity to *Sambucus*, inasmuch that if *Sambucus* be kept in this order, *Rhus* must accompany it. So also must the sister shrubs *Schinus* and *Fagara*."

"The *Dumosa* all agree in malignant qualities. They are either purgative, or altogether poisonous, as *Sideroxylum* is known to be at the Cape. Nor are the species of *Sambucus* clear of this charge, for their qualities are either nauseous or fetid, and therefore sudorific, especially the berries and flowers. The bark, taken internally, is either emetic, or powerfully purgative, as its vinous infusion proves in the dropsy; externally it is a powerful repellent."

"*Rhus* is the most venomous of trees, particularly its American three-leaved species, called *Toxicodendron*, or Poison-trees. Their fumes in burning are said to have proved mortal, and their effluvia to have blinded an artist who was at work upon some of the wood. Those who, being in a perspiration, hold a branch of one of these shrubs in the hand, are seized with an eruption over the whole body."

"The bark of *Rhamnus Frangula* is our best indigenous purge, and a syrup of *Rhamnus catharticus* is safely used for children."

"In this tribe, therefore, some have opposite, others alternate leaves, nor is any general character to be derived from the parts of fructification. The corolla affords none, being either of one or five petals, or altogether absent, as appears from a contemplation of the characters of the different genera. No mark is to be obtained from the nature of the fruit, that being either a berry, drupa, or capsule. The seeds in some instances are solitary, in others numerous, though never more than one in each cell; and it is well worthy of observation that they are attached, as in the *Gymnotetrasperma*, by their base. These plants betray some affinity to the *Tricocca*, but can never be referred to the same order."

In the Linnæan manuscript before us *Diosma* and *Hartogia* are introduced between *Callicarpa* and *Euonymus*; see our remark on the 26th order. *Staphylea* is also subjoined, near *Celastrus*, but with two marks of doubt, and a note of its having a nectary, as well as opposite leaves.

Order 44. SEPIARIÆ. "All these are shrubby or arborescent. Leaves opposite, with scarcely any evident stipulas. Flowers disposed in a more or less dense panicle. Calyx four-cleft. Corolla four-cleft, regular. Stamens two. Pistil one, with a cloven stigma. Fruit either a drupa, with one, two, or many seeds, or a capsule."

No manuscript remark occurs here, nor is there any observation worth copying in the lectures, except that *Olea* is said by Linnæus to be scarcely a distinct genus from *Phillyrea*.

Order 45. UMBELLATÆ. "The name of this order is derived from the form of its inflorescence, whose stalks all spread from a centre, like the ribs of an umbrella."

"These plants are either perfectly umbellate or not. The former are required to have a compound

Botany.

umbel, each stalk, or ray, of which ends in a receptacle, producing other stalks bearing flowers, or florets; the latter have a simple umbel, whose stalks are not subdivided. The latter constitute a separate section in Tournefort's system. They are comprehended by Linnæus in one natural order with the former."

"An umbel is properly a receptacle of a compound flower, elongated into stalks; which manifestly appears in *Eryngium*, whose florets are united into a head, just like the proper compound flowers, see the 49th order; nor are they supported by elongated stalks. Hence an umbel may accurately be considered as a compound flower. Those who controvert the opinion of Linnæus in this point contend, that many umbellate plants, having male and hermaphrodite flowers in the same species, ought to be placed in his class *Polygamia*. But this is a mistake; for no other plants ought to find a place in that class, than such as have distinct male, or female, as well as hermaphrodite, flowers, in the same species. This is not the case with the *Umbellatæ*, in which all the florets of one universal umbel, that is, the whole umbel itself, constitutes but one flower, and this flower is never altogether barren, that is, its florets are never entirely male. On the contrary, these florets are to be considered as the parts of a compound flower; and there being male and hermaphrodite ones intermixed, is exactly a parallel case with the polygamy of the Syngenesious class."

"This order is eminently natural, though all plants which bear umbels do not belong to it, but only those with five stamens, two styles, and two seeds."

"The germen is inferior, simple, solitary, separating, when arrived at maturity, into two equal naked seeds; each of which is furnished with a thread, inserted into its summit. These two threads combine to form a very slender receptacle, at the top of the stalk of the floret. Each floret has a superior perianth, with five teeth, which is often so small as scarcely to be discerned, even with the help of a magnifier. Petals five, caducous, often unequal; hence Rivinus referred these plants to his class of pentapetalous irregular flowers. Stamens five, inserted into an elevated annular or circular receptacle, that surrounds the pistils, deciduous. Styles two, often very short, and hardly visible. Seeds naked, without any seed-vessel."

"The stem is mostly hollow, sometimes filled with spongy pith; rarely shrubby, very rarely arborescent, of which last character *Phyllis* is the only example, see order 47. Leaves generally alternate, and repeatedly compound. Root mostly quite simple; in *Oenanthe* tuberous; in *Bunium Bulbocastanum* globose."

"Nothing is more arduous than to distinguish the genera of umbelliferous plants by appropriate characters. Tournefort himself, who excelled in the knowledge of this tribe," (perhaps Linnæus meant rather to say, in the discrimination of genera, but his auditors did not take his words accurately,) "has distributed them according to the shape and size of their seeds. But this is a very fallacious mode, as the seeds often differ much in proportion, though

Botany. not in any other respect. Morison wrote an entire book on umbellate plants; but with little success, their genera not being, as yet, established. Artedi first paid attention to the *involucrum*, which is either universal as well as partial, or only partial, or entirely wanting. This principle has likewise been adopted, as fundamental, by Linnæus, and his three primary divisions are regulated accordingly. The inequality of the petals affords him a principle for his leading subdivisions, some of the umbelliferous family having the outermost petals of their external florets larger than the rest; while in others all the petals are equal. The former are termed radiant flowers. Another subdivision is taken from the sex of the florets. Some of these, having no germen, are furnished with stamens only; and such florets are termed abortive; others, having both germen and stamens, bring their fruit to perfection, and are therefore denominated fertile."

On these principles Linnæus has arranged the umbellate plants, as may be seen in his works. Nothing occurs in his manuscript, except the insertion of *Hermas* next to *Eryngium*.

Order 46th. **HEDERACEÆ.** The lectures give no new information concerning this order. The six genera stand as in the *Genera Plantarum*; *Panax*, *Aralia*, *Zanthoxylum*, *Hedera*, *Vitis*, and *Cissus*.

Order 47th. **STELLATÆ.** "This order was founded by Ray, and received its name from the leaves of most of the plants which compose it being placed, four, six, or eight together, in the form of a star, round the stem. It is unusual to see more than two leaves opposite to each other, nor is it the case here. For two of these only are properly leaves, the rest being no other than stipulas, grown to the size of leaves. This appears evident in several Indian plants of the present order, as *Knosia*, *Diodia*, &c. which have only two opposite leaves, though between these some small acute stipulas are found, being the same that in the rest of the order attain the magnitude of leaves. Ray believed all the plants of this order to have whorled leaves, which is generally the case, as far as regards those of European growth, but rarely with the Indian ones, of which few were known in his time."

"In this order there is no tree, unless perhaps *Lippia*; there are very few shrubs, most of the tribe being small herbs, growing in barren earth, or coarse sand."

"The roots are in many instances perennial. Leaves opposite, horizontal, mostly rough. Stipulas of the form and aspect of leaves, so that it is impossible to say whether they be truly such or not, hence the leaves appear whorled; but this does not hold good universally. In those however which have no leafy stipulas, there is found, at each side, a sort of toothed membrane, connecting the leaves together, and occupying the place of stipulas."

"The stem is jointed, with mostly tumid knots. Corolla of one petal, either flat, wheel-shaped, or funnel-shaped; in one genus bell-shaped; mostly four-cleft, sometimes almost down to the base; rarely five-cleft. Stamens four, never eight, though sometimes five or six, in which case the corolla has a parallel number of segments. Pistil: solitary, divid-

ed; in *Richardia* three-cleft, because that genus has a six-cleft corolla, six stamens, and a three-grained fruit, its parts of fructification being all augmented in a similar proportion. Those parts are not augmented with the same regularity in genera furnished with a three-cleft corolla, and five stamens, for their pistil is still bifid, and their fruit two-grained, as is the case with such as have a four-cleft corolla and four stamens.

"The fruit is, for the most part, inferior; though superior in *Houstonia*; and in *Crucianella* superior with respect to the calyx, though inferior to the corolla." This is incorrect, for *Crucianella* has a real superior perianth, like the rest of the order, though so small as to be hardly discernible; what Linnæus here terms calyx, being an involucre, or perhaps bractæas. "The sexes are rarely separated in this order, though *Valantia*, which is polygamous, can by no means be excluded from it. Many of the genera have a two-grained fruit, of two cells, with a solitary seed in each. But in *Hedyotis* and *Oldenlandia* the cells contain many seeds; while in *Cornus* both cells are united into one seed, which, nevertheless, has two cells. The fruit has a green, fleshy, but not juicy, coat, nor does it usually become coloured in ripening; though in *Rubia* the fruit is a perfect berry."

(Of the remarks on particular genera, we find nothing to extract except the following.)

"*Asperula tinctoria* is used in Gothland instead of Madder, and is preferable."

"*Sherardia* has an oblong fruit, which the permanent calyx renders toothed, or crowned with three points. It was the fate of William Sherard, a man worthy, in the highest degree of botanical honour, to have two different genera distinguished by his name, both which were afterwards referred to others. Pontedera, Vaillant, and Dillenius each published, at the same time, a *Sherardia*. Pontedera described his plant so very obscurely, that it was ten years before Linnæus made it out to be his own *Gallenia*. Vaillant called the two-seeded *Verbena* by the name of *Sherardia*, but he was to blame in separating them from their proper genus. Dillenius named a *Sherardia*, from among the *Stellatæ*, which Linnæus has retained, though not very certainly distinct. Being unwilling that so meritorious a botanist should remain without a memorial, Linnæus declined referring the plant in question to *Asperula*; especially as the three teeth, at the top of each seed, may serve, if not very satisfactorily, to keep it separate."

"*Valantia* was so named by Tournefort; but Vaillant, perceiving it to be the same with Tournefort's *Cruciata*, thought it a bad genus, which could not support itself. He therefore wished to abolish all generic names, given in honour of botanists, because he supposed his own was untenable. But Tournefort confounded several genera under the appellation of *Cruciata*, so that Linnæus has been enabled to establish a *Valantia* from among them, referring the rest to their proper places."

Order 48. **AGGREGATÆ.** "These constitute a natural order, first established by Vaillant in the Memoirs of the French Academy of Sciences. They agree so far with the *Compositæ*, that they have generally a common calyx, as well as receptacle, con-

Botany. taining many sessile flowers, each of which has always an inferior germen. But there is a total difference with respect to the remaining parts of fructification, nor can these two orders be, by any means, united."

"The calyx, as we have just said, is common to many flowers. Common receptacle either naked, villous, hairy, or scaly. In the place of a partial calyx is the corolla, generally of one petal, regular or irregular, in four or five divisions, rarely polypetalous. Stamens four, with separate anthers. Germs inferior. Fruit single-seeded. The flower is therefore complete in this tribe, except only *Valeriana*, whose calyx is scarcely apparent. The leaves are often opposite, and the stem shrubby."

Order 49: **COMPOSITÆ.** "A compound flower generally consists of a common calyx, containing several florets. But this definition is not sufficiently discriminative, for there are certain flowers termed *Aggregate*, which though they have numerous florets in one common calyx, are connected by no affinity whatever with these; witness *Cephalanthus*, *Dipsacus*, *Scabiosa*, *Knautia*, *Allionia*. Hence botanists have tried to discover an appropriate and distinguishing character for a compound flower, but they have scarcely succeeded. There are indeed flowers of this order, furnished with solitary florets in each calyx, as *Seriphium*, *Corymbium*, *Strumfya*. All of them have a monopetalous corolla, but so has *Scabiosa* and others. Most have five stamens, but some have only four. The greater number bear their anthers united into a cylinder, but *Kuhnia*, which belongs to them, has separate anthers; while *Jasione*, *Viola* and *Impatiens*, which do not, have combined ones. The united anthers burst internally, by which means their pollen is communicated to the stigma; but the anthers of *Kuhnia* open at the extremity, and resemble the corolla of an *Aristolochia*. All the florets are superior, but this holds good likewise in *Scabiosa*. Hence it appears that no essential character of compound flowers is to be detected, though no order can be more natural than that before us."

"Tournefort first divided the compound flowers into three sections, according to the shape of their partial corollas. These are either ligulate or tubular. Such as consist of ligulate florets only, are called by this writer *semiflosculosi*; such as are formed only of tubular ones, *flosculosi*; while those which have ligulate florets in the radius, and tubular ones in the disk, are denominated *radiati*. This division seems natural enough, and yet is not so. For it refers both the discoid and capitate compound flowers of Linnæus to the *flosculosi*, which nevertheless are too dissimilar to be possibly admitted into the same section. The *discoidei* of Linnæus, Ray's *aggregati*, having aggregate florets, seated on a hemispherical receptacle, are, in fact, more allied to the *radiati*; while the *capitati*, such as Thistles, are widely different, so as necessarily to constitute a division by themselves."

"Vaillant attempted a new botanical system; but it is to be lamented that we are possessed of no more of his labours, than what concerns the compound flowers. In this performance, published in the *Memoirs of the Parisian Academy* for the years

1718, 1719 and 1720; he has displayed an extensive knowledge of species, and has treated the subject admirably. As the *Memoirs of the Academy* are not within the reach of every body's purse, a German named Von Steinwehr has collected the anatomical, chemical and botanical papers, into an octavo volume, published in 1754 at Breslaw. In this Vaillant's treatises are preserved entire," (but in the German language.)

"The florets of compound flowers are threefold with respect to sex, being either *hermaphroditic*, perfect, having the organs of both sexes; female, destitute of anthers; or neuter, deprived of both organs, and barren."

"Tournefort, Vaillant, Ray, and almost every botanist who has treated of this tribe, divide it into three or four orders, some of them adding the aggregate flowers to the compound ones, whence arises the fourth order. But they have not fixed limits to their orders, such being scarcely discoverable. The *semiflosculosi* and *capitati*, for instance, though apparently widely different, are proved nearly akin by *Scolymus* and *Elephantopus*. The former of these has all the habit of a *Carduus*, and yet all its florets are ligulate; the latter is intermediate between the *semiflosculosi* and *capitati*, nor are we certain to which of these divisions it belongs. *Perdicium*, a new genus, connects *Inula*, which is radiated, with the semiflosculous genus *Hieracium*, so that accurate limits are hardly to be drawn between them. Most of the *semiflosculosi* are milky, but *Lapsana* and *Cichorium* want this quality."

"Section 1. *Semiflosculosi*; all the florets ligulate."

"These genera are distributed, first by their receptacle, which is either chaffy, villous, or naked. In the next place, they are subdivided by the down of their seeds, *pappus*, which is either absent, or bristle-shaped, or hairy, or feathery. Thirdly, a peculiar distinguishing character is borrowed from the form or nature of their calyx."

"The quality of the *Compositæ* in general is innocent; but some of the present section are milky, which secretion proves, by experience, somewhat of a poisonous nature. So *Lactuca virosa*, in a wild state, is as poisonous as opium; yet by culture it becomes esculent and culinary, though still causing sleep by its debilitating power." Linnæus surely could not mean that this and the garden lettuce are one species. It is possible his hearers mistook him.

"There are no trees, and few shrubs, among the *semiflosculosi*; no bulbs, scarcely a tuberous root, except in some species of *Hieracium*. Their flowers are mostly yellow; sometimes red underneath, as in *Leontodon*, *Hieracium* and *Crepis*;" (very rarely pink, in *Geropogon* and *Crepis*); "sometimes blue, in *Cichorium* and *Catananche*; never white."

"Section 2. *Capitati*; all the florets tubular; assembled into a head, in one common calyx."

"All these are prickly or spinous, and vulgarly called *Cardui*, Thistles. If however they were all considered as one genus, such a genus would prove too ample; hence it is best to separate them into several, though the task is very difficult. *Centaurus*

Botany. belongs to them; though necessarily referred, in the sexual system, to the order *Polygamia-frustranea*. Its calyx, always tumid, and often spinous, proves its affinity. The most extensive genera of this section, *Carduus*, and *Serratula*, are the most difficult to distinguish; hence it is best to study the rest, in the first place, that those puzzling ones may prove easier."

"Vaillant divided this capitata tribe by the spines of their calyx, whether simple, spinous, or leafy. But the gradation is so imperceptible, that no accurate principles of discrimination are hence to be obtained. No plant of this section is milky, or poisonous, or arboreous. Some of the *Serratulae* are shrubby; many of the herbs are destitute of stems, as in *Carlina*, *Atractylis*, *Onopordum*, *Carduus*, and *Centaurea*."

"*Atractylis* has a radiant flower, and the florets of the radius have each both stamens and pistil, a solitary instance among compound flowers, rendering the genus very distinct. The elongated and coloured scales of the calyx in *Carlina* have misled Tournefort to rank it among radiant flowers."

"The *capitati* have a character peculiar to themselves, in the dilatation, or inflation, of the tube of each floret, just below the limb, which causes their florets to project, in a more elongated manner, than in the *discoidei*, or other compound flowers."

"Section 3d. *Discoidei*. The first subdivision of these, *polygamia aequalis*," (consisting of such as have all the florets furnished with stamens and pistils, and all producing seed,) "are distributed according to the receptacle, whether naked, chaffy or hairy, and their seed-down, like the *semiflosculosi*."

"The second subdivision, *polygamia superflua*, have female florets in the circumference, but these are tubular, not ligulate or radiant. So that the flowers, though they have a marginal series of female florets, cannot be called radiated." We have here extracted the ideas of Linnæus from his remarks on *Artemisia*, which seem to refer to the whole of this subdivision, and are certainly correct, though they interfere with the distribution of the order before us in the *Genera Plantarum*, and seem to have been unintelligible to the editor of the *Prælectiones*; see his note in p. 599 of that work.

"Section 4th. *Radiati*." (Marginal florets radiant.) "The first subdivision is *polygamia superflua*," (all whose florets are capable of producing perfect seed, though the marginal radiant ones have no stamens.)

These are distinguished by the presence or absence of seed-down, or of a membranous border to the seed, and by the nature of their receptacle, whether naked or chaffy.

The second, *polygamia frustranea*, has imperfect or defective female or neuter florets in the circumference, producing no seed. These in *Centaurea* are tubular, and neuter; in the rest ligulate, furnished with rudiments, more or less evident, of a pistil.

The third, *polygamia necessaria*, have effective seed; bearing female florets in the circumference only.

Botany. "Section 5th. *Monogamia*." (Such as have but one floret in each partial calyx.)

Scirpium, *Corymbium*, and *Strumpfia*.

"None of the *Compositæ* are poisonous, except *Tagetes*, *Doronicum*, and *Arnica*; the latter is more so than *Doronicum*. They contain much of a bitter flavour; hence many of the order are medicinal and strengthening. Some, less bitter, as *Arctium*, *Cynara*, *Carduus*, are therefore esculent. Many *semiflosculosi* are used as food, though furnished with a milky juice, which in them is not poisonous," (see a remark under Order 30th.) "except *Lactuca virosa*, whose juice as above mentioned, has the quality of opium, and *L. sativa* has a soporific virtue. Boiling entirely destroys the power of this, as well as of the other *semiflosculosi*."

Order 50th. *AMENTACEÆ*. "An *amentum*, catkin, is a species of calyx, and very like a spike, consisting of a common receptacle, drawn out like a thread, on which the flowers stand in alternate order, subtended by scales or bracteas. Such a calyx is found in the plants of this order, whence Linnæus gave it the above name. They are all either trees or shrubs, with alternate leaves, and separated male and female flowers, being either monoecious or dioecious. Many of them produce but one seed from each flower; but *Salix* and *Populus* bear a seed-vessel of two valves, with many seeds. The styles are usually two or three. The flowers come before the leaves, that the latter may not hinder the access of the pollen of the male to the female blossoms."

"Monoecious genera are *Betula*, *Carpinus*, *Corylus*, *Quercus*, *Juglans*, *Fagus*, and *Platanus*."

"Dioecious ones *Pistacia*, *Myrica*, *Populus* and *Salix*."

Order 51st. *CONIFERÆ*. "These are generally evergreen trees of cold climates. In the Indies almost all the trees are evergreen, and have broad leaves; but in our cold regions most trees cast their foliage every year; and such as do not, bear acerose, that is, narrow and acute, leaves. If they were broader, the snow which falls during winter would collect among them, and break the branches by its weight. Their great slenderness prevents any such effect, allowing the snow to pass between them. This precaution is unnecessary in India, where snow is unknown. Nevertheless, *Liquidambar* is to be referred to this order, though it bears no such slender, but rather broad, foliage; nor is it a native of a cold country."

"The plants of the present order are denominated *Coniferae*, because they bear *Strobili*, which the older botanists called *Coni*, Cones. A cone and a catkin are closely related to each other. The latter bears several imbricated flowers about a common receptacle or axis. Under each flower a membranous scale or bractea is attached, which if it hardens and becomes woody, the catkin becomes a cone. Hence a cone is nothing more than a permanent or hardened catkin."

"All the *Coniferae* properly bear cones, though in some instances their fruit seems of a totally different nature. For instance the fruit of *Juniperus* has

Botany. all the appearance of a berry, and is universally so called. Yet it is no other than a *strobilus*, whose scales are replete with pulp, and do not split asunder; being in fact six fleshy united scales, in each of which is concealed a solitary seed. *Taxus* has a berry, which is merely a fleshy receptacle, dilated so as nearly to cover the seed, so that the apex of the latter only appears. *Liquidambar* has a singular kind of fruit, which nevertheless is a *strobilus*, whose scales are combined, each of them containing several seeds; whereas in other instances one or two seeds only belong to each scale."

"Some have united this order with the last, but they differ essentially. The *Coniferae* have not only hardened scales, but likewise monadelphous stamens, the filaments of all of them being combined at the base."

"The fruit in this whole order, *Liquidambar* excepted, is biennial. It is produced in the spring, remaining in an unripe state through the summer, and till the following spring, when it gradually ripens, and the gaping scales allow the seeds to escape."

Order 52d. COADUNATÆ. On this order there is no observation in the lectures. *Illicium* is added in manuscript to the genera in *Gen. Pl.*

Order 53d. SCABRIDÆ. Here also the lectures are silent. *Forskohlea* and *Trophis* are added in the manuscript.

Order 54th. MISCELLANÆ. Here, although no remark is preserved in the lectures, great corrections are made in the manuscript. The genera in the second section, *Poterium* and *Sanguisorba*, are referred to the 35th order, immediately before *Agrimonia*. *Pistia* and *Lemna* constituting the 3d section, are transferred to the 15th order. The six genera which compose the 5th section, are sent to the 4th section of the *Holeraceæ*, order 12th. *Nymphaea* and *Sarracenia*, the only plants of the 6th section, are referred, as already mentioned, first to the 27th order, but finally, not without a doubt, to the 11th. See the observations under those orders. *Cedrela* and *Swietenia*, which make the 7th section, are removed to the *Trihilatae*, order 23d. *Corrigiola*, *Linum* and *Telephium*, the 8th and last section, are transferred to the 5th section of the 12th order, *Holeraceæ*. No genera therefore remain in this 54th order, but *Reseda*, *Datisca*, *Coriaria*, and *Empe-trum*.

Order 55th. FILICES.

—— 56th. MUSCI.

—— 57th. ALGÆ.

—— 58th. FUNGI.

Nothing occurs here, either in the *Prælectiones* or the manuscript, to the purpose of our present inquiry, concerning the ideas of Linnæus on natural classification. These orders are all natural, and acknowledged as such by all systematics. His particular observations on each, although in many points curious, are now superseded by the advanced state of botanical knowledge in the cryptogamic department.

Remarks on the foregoing Arrangement. From the foregoing copious exposition of the general principles, and many of the particular opinions, of Linnæus, respecting a natural classification of plants, it will appear how far he was from consider-

ing his performances, in this line, as complete. His leading ideas may, nevertheless, be traced, and they will often be found to throw great light upon the subject. It must be remembered that he never thought his own, or any other, scheme of natural classification, could or ought to interfere with his artificial system, nor does he ever advert to the one, in treating of the other. It is evident, likewise, that he studiously discouraged any attempt at an uniform definition, or technical discrimination, of his several orders. He perceived that plants were not yet sufficiently known to render such a scheme practicable. Possibly he might be aware that the accomplishment of that scheme at present would only turn his natural system into an artificial one.

The authors of most plans of botanical classification have, on the other hand, seldom considered the questions of natural and artificial arrangement, as opposed to each other. The system of every such author seems to have appeared to himself the most consonant to nature, as well as the most convenient in practice; yet nothing betrays a more absolute incompetency to the subject than such an idea, wherever it makes itself manifest. To pretend that the elaborate speculations of a proficient, on a subject of which he can see but a part, and on which his knowledge must necessarily be inferior to that infinite wisdom which planned and perfected the whole, should be an easy and certain mode of initiation for a learner, evinces no more than that the professor wishes his pupil should not be wiser than himself. To teach composition without a grammar, or philology without an alphabet, would be equally judicious. Plants must be known before they can be compared, and the talent of discrimination must precede that of combination. Clearness and facility must smooth the path of the tyro; difficulties, exceptions, and paradoxes must be combated and unravelled by an adept. The knowledge of natural classification therefore, being the summit of botanical science, cannot be the first step towards the acquirement of that science. No person surely, who has published a natural system, without knowing all the plants in the world, will suppose that he has removed every present obstacle, much less, anticipated every future obscurity, so that no insuperable difficulty can occur to the investigator of plants by such a system. Neither can any artificial system claim such perfection. But they may combine their powers, and cooperate in instruction. The one may trace an outline which the other may correct and fill up. The first may propose, and the second elucidate; the former may educate and improve the memory and observation, for the use of the latter. When they oppose each other, their several defects and weaknesses appear; by mutual assistance they strengthen themselves.

Whether the leaders of natural system in the French school of botany have thought with us on this subject, it might seem invidious to inquire too nicely. It were too much to expect that every one of their pupils, half learned and half experienced, however commendable their zeal and enthusiasm, should have done so. Nor is science in any danger if they do not. They must improve the system of

Botany. Jussieu, before they can overturn that of Linnæus; and if this were accomplished, the nomenclature and definitions of the learned Swede would still form an impregnable fortress, before which they must perish, or seek for shelter within. This dilemma has been, long ago, but too clearly perceived by the rivals of the fame of Linnæus, particularly by such of the French school as have been actuated by a truly contemptible national partiality, instead of a disinterested love of science and truth. Hence the so often repeated exclamations against Linnæus, as a mere nomenclator. Of his didactic precision, and philosophical principles of discrimination, such critics were not jealous, for they could not estimate the value nor the consequences of these. But they could all feel that the nomenclature of Tournefort was giving way, and that their efforts to support it were vain. The writer of these remarks has perceived traces of this feeling in almost every publication and conversation, of a certain description of botanists. He has likewise perceived that it would gradually subside, and that the interests of science were secure. The nomenclature of Linnæus has in the end prevailed, and it were unjust now, to the greatest botanists of the French school, to deny them the honour of liberality on this head.

It is time for us to close this article, with a view of the principles, upon which the eminent systematic, to whom we have so often alluded, have planned and executed their schemes of botanical classification.

Bernard de Jussieu. Here the learned and truly estimable Bernard de Jussieu, the contemporary of Linnæus in the earlier part of his career, first claims our notice. This great practical botanist, too diffident of his own knowledge, extensive as it was, to be over anxious to stand forth as a teacher, did not promulgate any scheme of natural arrangement till the year 1759, when the royal botanic garden at Trianon was submitted to his direction. His system was published by his nephew in 1789, at the head of his own work, of which it makes the basis. It appears in the form of a simple list of genera, under the name of each order, without any definition, just like the *Fragmenta* of Linnæus, at the end of his *Genera Plantarum*.

Adanson. In 1763 a very active and zealous systematic, M. Adanson, made himself known to the world, by the publication of his *Familles des Plantes*. In this learned and ingenious, though whimsical and pedantic, work, the great task of defining natural orders by technical characters is first attempted. His affected orthography and arbitrary nomenclature render it scarcely possible, without disgust, to trace his ideas; which however, when developed, prove less original than they at first appear. His work is written avowedly to supersede the labours of Linnæus, against whom, after courting his correspondence, he took some personal displeasure; and yet many of his leading characters are borrowed from the sexual system. The discriminative marks of his 58 families are taken from the following sources—leaves, sex of the flowers, situation of the flowers with respect to the germen, form and situation of the corolla, stamens, germens, and seeds. Every family is divided

into several sections, under each of which the genera are in like manner synoptically arranged, and discriminated by their leaves, inflorescence, calyx, corolla, stamens, pistil, fruit, and seeds. In the detail of his system, Adanson labours to overset the principle, so much insisted on by Linnæus and his school, and to which the great names of Conrad Gesner, and Cæsalpinus are chiefly indebted for their botanical fame, that the genera of plants are to be characterized by the parts of fructification alone. The experienced botanist knows that this is often but a dispute of words; Linnæus having, in arranging the umbelliferous plants, resorted to the inflorescence, under the denomination of a receptacle; see his 45th natural order. But it appears to us that the characters deduced from thence are in themselves faulty, being often uncertain, and not seldom unnatural; and that the plants in question may be better discriminated by their flowers and seeds. Adanson however prefers the inflorescence, even in the *Verticillata* of Linnæus; for no reason, that we can discover, but because Linnæus has so much better defined the genera of those plants by the *calyx* and *corolla*. It were a needless and ungrateful task to carp at the mistakes of this or any writer on natural classification, with regard to the places allotted for difficult genera, because the human intellect must faultier in unravelling the intricate mysteries of Nature. But surely, when *Plantago* is placed with *Buddlæa* in one section of the *Jasmineæ*, and *Dianthus* with *Callicarpa* in another; when the most natural genus of *Lavandula* is divided and widely separated; when *Cassitha* is ranged with *Statice*, *Eriocaulon*, and the *Proteaceæ*, in one place; *Geoffræa* with *Melia*, *Rhus*, *Sapindus* and *Ruta* in another, we may be allowed to wonder, and to doubt whether we are contemplating a natural or an artificial system. It does not appear that Adanson made many proselytes. He haunted the botanical societies of Paris in our time, without associating with any; nor was his extensive knowledge turned to much practical account. Linnæus has made but one slight remark, that we can find, in his own copy of the *Familles des Plantes*, nor could he study deeply what was, undoubtedly, very difficult for him to read. He certainly never noticed Adanson's attacks, unless the satirical sketch of the *Botanophili*, at the end of his *Regnum Vegetabile*, (see the beginning of *Syst. Veg. ed. 14.*) be partly aimed at this author. To apply the whole of it to him would be unjust, though much is very characteristic.

The study of Botany had never been entirely neglected in France since the days of Tournefort; because one department in the Academy of Sciences was allotted to that and other branches of Natural History, and the seats in the Academy being pensioned places under government, there was something to be got by an apparent attention to such pursuits. Buffon and his pupils engrossed Zoology. Botany was allowed to exist, so far as not to interfere with his honours; but nothing of foreign origin, and above all, nothing Linnæan, dared to lift up its head. Something of true science, and practical knowledge, did nevertheless imperceptibly work its way. Le Monnier, and the Marechal de Noailles,

Botany. corresponded, as we have already said, with Linnæus, and acquired plants from England, of which they dared to speak, and to write, by his names. A most able and scientific botanist and cultivator, Thouin, was established in the Jardin du Roi, who studied the Linnæan system, and even ventured, though secretly, to communicate new plants to the younger Linnæus when at Paris. Cels, an excellent horticulturist, was unshackled by academic trammels. L'Héritier, Broussonet, and others came forward. An original letter of Rousseau, the idol of the day, in which he paid the most flattering homage to Botany and to Linnæus, was published in the Journal de Paris, and had a wonderful effect on the public mind, and on the conversation of literary circles. In short, a Linnæan party had been, for some time, gaining ground; and every thing was done by party at Paris. The old French school was roused from its slumbers. Of the family of the Jussieus one individual remained, who, though he venerated the names and the pursuits of his uncles, had never devoted himself to their studies any further than to sit in their professorial chair. He possessed however an inherent taste for Botany; he had leisure, opulence, and eminent talents; and though his religious principles, and his rather strict devotional habits, might interfere, which they still do, with his credit in certain philosophical circles, and his predilection for animal magnetism might exclude him from the Royal Society of London, yet he has risen above all such obstacles, to the summit of botanical fame and authority in his own country; and his name stands conspicuous, as the leading teacher of a natural classification of plants. The most indefatigable study for about five years, and the constant assistance and encouragement of numerous pupils and correspondents, enabled Professor Antoine Laurent de Jussieu to publish, in 1789, his *Genera Plantarum secundum ordines naturales disposita*. This octavo volume was received by acclamation throughout Europe, and hailed as the most learned botanical work that had appeared since the *Species Plantarum* of Linnæus.

Antoine de Jussieu.

Before we enter into systematic details, we must remark, that the author of the work before us has judiciously availed himself of the mode of defining genera, by short *essential* characters, as introduced by Linnæus in the 10th edition of his *Systema Naturæ*, and since adopted by Murray, Willdenow, and the generality of botanists, instead of the full or *natural* characters, of the Linnæan *Genera Plantarum*. These short characters however are not servilely copied by Jussieu, but wherever he had materials they are revised and studied, so as to acquire all the merit of originality. Secondary characters and remarks are subjoined, in a different type, illustrative of the habit, history, or affinities, of the several genera. In his nomenclature Jussieu almost entirely follows Linnæus, retaining only here and there a name of Tournefort's in preference, and swerving from classical taste and correctness principally with regard to the new genera of Aublet, whose intolerably barbarous names are nearly all preserved. But a note in the preface, p. 24, informs us, that this adoption is only temporary, till the genera themselves

shall be perfectly ascertained and defined. Where **Botany.** Jussieu differs from Linnæus, in certain generic appellations, it is principally because the latter fails in respect for his own laws; as in the use of adjectives, like *Gloriosa*, *Mirabilis*, *Impatiens*. The inordinate abuse of generic names in honour of botanists, of which Linnæus is, too justly, charged with setting the example, meets with due reprobation from the French teacher; but he has not as yet stemmed the muddy torrent, nor prevented a great additional accumulation of subsequent impurities. His commendation of Linnæus, as the author of a new and commodious system of specific nomenclature, as well as of technical definition, on the best principles, is liberal, manly and just, no less honourable to the writer, than to the illustrious subject of his remarks. The whole preface of Jussieu is a concise and learned review of the physiology and distinctions of plants, more particularly explaining the progress of the author's ideas and principles of botanical classification. The main end of the whole book, besides defining the characters of all known genera, is to dispose them in a natural series, in various classes and orders, whose technical distinctions are throughout attempted to be fixed and contrasted. With this view, copious explanations and commentaries accompany each other. We learn more from the doubts of Jussieu, than from the assertions of Adanson. The latter has presented us with a finished system, where every genus is referred, at all hazards, to some place or other. Jussieu, on the contrary, has not only a large assemblage of *Plantæ incertæ sedis*, at the conclusion of his system, like Linnæus; but at the end of most of his individual orders we find some genera classed as akin thereto, without answering precisely to the character, or *idea*, of each. This circumstance, though highly creditable to the candour and good sense of the author, greatly interferes with the practical use of his book, except for the learned. His judicious doubts, critical remarks, and especially the laxity, and consequent feebleness, of his definitions, though eminently instructive to those who want to define, or to class, a new, or obscure genus, could only bewilder a learner of practical botany. A person must already be deeply versed in plants, before he could, by the work of Jussieu, or by any book, that we have seen, classed according to his method, refer any genus to its proper place, or detect any one that may be there described. Nor does the difficulty to which we allude consist so much in the intricacy of the subject, as in the uncertainty, hesitation, and insufficiency of the guide; because that guide, learned as he is, chooses to conduct us by a path, to which neither he nor any other mortal has a perfect clue. His index indeed must be the resource of a young botanist; who, if he knows a *Rosa*, a *Convolvulus*, or an *Erica*, may, by finding their places and their characters, trace out the allies of each, and proceed step by step to acquire more comprehensive ideas. The analytical mode of inquiry, which serves us in the artificial system of Linnæus, is here of no avail but to an adept. This will abundantly appear as we trace the leading principles of this celebrated method, of which we shall now attempt a concise exposition.

THE SYSTEM OF JUSSIEU

Consists of fifteen classes, which are composed, all together, of one hundred orders. The characters of the classes depend first on the number of cotyledons; next the number of petals, and the situation, or place of insertion, of the stamens and corolla.

The author uses the term *stamina hypogyna* for such stamens as are inserted into the receptacle, or below the germen, which therefore we shall call *inferior stamens*; *stamina perigyna*, (around the germen), are inserted into either the corolla or calyx, the germen being superior; these we must denominate *perigynous*; *stamina epigyna, superior stamens*, are inserted above the germen, which latter is therefore, in Linnæan language, *inferior*. The same terms apply to the corolla, which when inserted into the calyx is denominated *perigynous*. The following table will show the characters of Jussieu's Classes:

- Cotyledons none.
- Class 1st.
- Cotyledon one.
- Class 2d. Stamens inferior.
- 3d. Stamens perigynous.
- 4th. Stamens superior.
- Cotyledons two, (or more).
- Class 5th. Petals none. Stamens superior.
- 6th. — — — — — Stamens perigynous.
- 7th. — — — — — Stamens inferior.
- 8th. Corolla of one petal, inferior.
- 9th. — — — — —, perigynous.
- 10th. — — — — —, superior. Anthers combined.
- 11th. — — — — —, — — — — —. Anthers distinct.
- 12th. Corolla of several petals. Stamens superior.
- 13th. — — — — —, — — — — —. Stamens inferior.
- 14th. — — — — —, — — — — —. Stamens perigynous.
- 15th. Stamens and pistils in separate flowers.

In the first place, it is evident that the great hinge, on which this system turns, is the number of the cotyledons. The importance of this character has, from the time of Cæsalpinus and Jungius, been much insisted on. Linnæus, in his *Prælectiones*, p. 329, declares his opinion, that "the monocotyledonous and dicotyledonous plants are totally different in nature, and cannot be combined;" and that "if this distinction falls to the ground, there will never be any certainty. Not that characters should be taken from hence, but sections when formed should be confirmed by the cotyledons." So jealous was this great man of any definition of his natural orders! He subjoins an exception to the above rule, in *Cuscuta* and *Cactus*, which having no leaves, he supposes have no occasion for cotyledons. Linnæus proceeds to observe that "the germination of parasitical plants requires investigation, but that he should greatly wonder if they have any coty-

VOL. II. PART II.

ledons." We have already, under the 11th of his natural orders, pointed out other exceptions, made by himself, to the rule just mentioned; but in these he was partly, as we have shown, mistaken; and had he been explicit about the *Sarmentaceæ*, he probably would have proved himself in an error likewise with respect to them. So Adanson asserts the *Juncus* to have two cotyledons, though the rest of its natural order have only one. But Gærtner has demonstrated this genus to be monocotyledonous. Adanson mentions *Orobanche* and *Cuscuta* as monocotyledonous, which answers to the opinion of Linnæus, but we know not how far this is just.

It appears that the line is distinctly drawn by nature between plants with a simple or no cotyledon, and others with two, or more, and that, so far, the principle of Jussieu's classification is correct. Whether all the genera that he has considered as monocotyledonous be truly so, is another question, which does not at all invalidate the distinction. Some have not been examined, and seem principally to be referred to that tribe, because, like others that indubitably belong to it, they are aquatics; or, at least, because of the apparent simplicity of their general structure. Doubts are expressed on this subject by Jussieu himself respecting *Valisneria*, *Cyamus* (his *Nelumbium*), *Trapa*, *Proserpinaca*, and *Pistia*. Some other genera, ranked as acotyledonous, are involved in similar uncertainty.

But with regard to the bulk of the *Acotyledones*, composing the first of Jussieu's classes, there seems to us much greater difficulty. Of his first three orders, *Fungi*, *Algæ* and *Hepaticæ*, nothing indeed is correctly known, except perhaps what Hedwig has published concerning *Marchantia* and *Anthoceros*, and that is hardly sufficient for our purpose. With the fourth order, *Musci*, this great cryptogamist has made us so well acquainted, that they prove to be any thing else than acotyledonous, or monocotyledonous; at least if his idea of the parts be right. The parts which he takes for cotyledons are peculiarly numerous and complicated; but we are ready to allow with Mr Brown, at the conclusion of the preface to his *Prodromus Floræ Novæ Hollandiæ*, that these organs are of a most uncertain nature, rather subsequent to germination than its first beginning, like what has been judged the cotyledon of Jussieu's 5th order, the *Filices*. Yet hence a new difficulty arises. The parts in question so complex in *Musci*, are simple in *Filices*, inasmuch that no analogy between these orders, otherwise so nearly akin, is to be traced in those parts. On the other hand, it cannot be concealed that the plants termed *monocotyledones* have no cotyledon at all analogous to those of the *dicotyledones*; what Jussieu and others call such, being the *albumen* of the seed, absorbed in the first stage of vegetation. The minute plants assumed to be acotyledonous, must be presumed to be furnished with something analogous, or we cannot conceive how vegetation can take place. By all these observations we mean only to show, that the primary divisions of Jussieu's system, are at least totally insufficient to answer that practical purpose, which a student has a right to expect from any methodical arrangement. If the learned be still uncertain, whether the distinctions, on which such divisions are founded

Botany.

do, in a great number of cases, really exist, how can a beginner regulate his first inquiries thereby? We are not the less ready to confess, that the difficulty in question is rather a philosophical speculation, than of any great practical importance. It gives a venerable air of mystery, which may procure respect for other parts of a system, that are more intelligible and more useful, though not free from exception. We allude to the next subdivision of the method of the great French teacher, founded on the petals. This should seem to be obvious and certain, but we soon find ourselves bewildered in an old labyrinth of dispute, concerning the difference between a *calyx* and a *corolla*. We are obliged to submit to a sweeping decision, which allows no *corolla* to monocotyledonous plants; a decision which we cannot safely combat, because of the difficulty of deciding what are such, but which shocks our senses and our judgment, and seems refuted in many instances by Nature herself, as decidedly as any of her laws can be established. Nor do we get clear of this perplexity among the declared dicotyledonous tribes, where the evident *corolla* of the Marvel of Peru is assumed to be an inner *calyx*, there being a real *perianth* besides, subsequently indeed called an *involutum*. Yet we are at a loss to discern why the terminology here used, should have been different from that applied to the next order, *Plumbagineæ*. We are ready, most unreservedly, to admit the great difficulty of decision in these cases, as well as in others, occurring in Jussieu's 5th, 6th, and 7th classes; but that very difficulty evinces the precariousness of making any thing connected with this most disputable of all questions, a primary guide in a system of methodical arrangement. When we proceed a step further, and come to the insertion of the stamens, the convenience and clearness of the system indeed improve upon our view; but we must not hope to escape exceptions or inaccuracies, the connection of the *filaments* with the *corolla* being, by no means, uniform or constant, in the orders so characterized, nor even in all the species of particular genera, classed upon that principle. So likewise the insertion of the *stamens* into the *calyx* is attended with such inveterate difficulties, that one of the warmest promulgators and defenders of Jussieu's system, Mr Salisbury, has thought it easier to deny the existence of any such insertion, than to make it subservient to practical use. We are indeed satisfied that the characters throughout the celebrated method of classification now under our contemplation, are attended with as much difficulty and exception as those of any other system, and we cannot but agree with Mr Roscoe, *Trans. of the Linn. Soc.* Vol. XI. 65, that it forms several as unnatural assemblages as even the professedly artificial system of Linnæus. With regard to practical facility, no person of judgment has ever attempted to invalidate the superiority of the latter.

Having fulfilled the invidious task, which truth has required of us, let us turn to the more pleasing one of pointing out some of the great practical advantages of the labours of Jussieu. We do this with the more readiness, because we conceive that his real merits are better understood in England than any where else. The writer of this cannot disclaim the honour of being

the first who announced to his countrymen the performance of his illustrious friend and correspondent, as one of the most learned books ever published. He humbly conceives that few persons, in any country, have studied the work more, or applied it so much to practice. If he has been fortunate in establishing genera, which have not been controverted, he allows his obligations to Jussieu, as much as to Linnæus. The treasures of neither lie on the surface, nor are they to be appreciated by a superficial observer. The foolish contentions of party can neither exalt nor invalidate the reputation of such men; nor is it the counting of stamens and pistils, nor the enunciation of the names of natural orders, implying ideas which do not always exist in the mind of the speaker, that can entitle a pedant or coxcomb to rank as the pupil of either.

We confess ourselves somewhat partial to the Linnæan notion, of conceiving the idea of a natural order in the mind, rather than to the Jussieuan attempt at very precise technical limitation of its characters. If we contemplate the generality of Jussieu's orders in this light, we shall be struck with his profound talents for combination, as well as discrimination; and as we peruse his critical remarks, subjoined to several of these orders, we shall profit more by his queries and difficulties, than by those definitions, at the head of each order, which are, too often, so clogged with exceptions, as to bewilder rather than instruct a student, however intelligible they may be to an adept.

The uninformed reader may, possibly, be surprised to see how great a conformity there is between most of the Natural Orders of Linnæus and those of Jussieu. This will appear by a cursory view of the latter, which, after the detail we have given of the former, will more elucidate the subject than any other explanation that our limits will allow. We shall take the orders of Jussieu in their regular series.

CLASS 1.

The first five orders, *Fungi*, *Alga*, *Hepatica*, *Musci*, and *Filices*, are the same in both systems, except that Linnæus does not separate the *Hepatica* from *Alga*.

6. *Naiades* are analogous to the *Inundata*, ord. 15, of Linnæus.

CLASS 2.

7. *Aroideæ* answer to the Linnæan *Piperitæ*, ord. 2, though *Piper* itself is removed far away, to the *Urticæ*.

8. *Typhæ* consist of *Typha* and *Sparganium*, two genera first referred by Linnæus to *Calamariæ*, then to *Piperitæ*.

9. *Cyperoideæ* are the Linnæan *Calamariæ*, ord. 3.

10. *Gramineæ* are the *Gramina*, ord. 4. grasses, an order about which there cannot be two opinions, nor do these authors differ, except in the denomination of the integuments of the flower; Jussieu calling the *calyx* a *gluma*, and the *corolla* a *calyx*. This alteration is made, chiefly that he might not allow a *corolla* to monocotyledonous plants.

CLASS 3.

11. *Palma*, palms, necessarily the same in both systems.

12. *Asparagi* answer to the bulk of the *Sarmen-taceæ*, ord. 11.

13. *Junci* agree less exactly with *Tripetaloideæ*,

Botany. ord. 5, both being liable to exceptions, and having undergone subsequent corrections by their respective authors.

14. *Lilia* consist of the latter portion of Linnæus's *Coronariæ*, ord. 10, with the beginning of his next order *Sarmentaceæ*.

15. *Bromeliæ* embrace some others of the *Coronariæ*, about which Linnæus had his doubts to the last, nor is Jussieu satisfied with this order.

16. *Asphodeli* are likewise chiefly *Coronariæ*, except *Allium*.

17. *Narcissi* are Linnæan *Spathaceæ*, ord. 9. We say nothing of anomalous or doubtful genera, subjoined to this or any other order, and which are sometimes numerous, not unfrequently paradoxical. In the present instance they are *Hypoxis*, *Pontederia*, *Polygonum*, *Alstroemeria*, and *Tacca*, concerning which, the intelligent reader will readily concur with the learned author, that they are "*genera Narcissis non omnino affinia*."

18. *Irides*—Linnæan *Ensateæ*, ord. 6.

CLASS 4.

19. *Musæ*—consist of *Musa*, very mistakenly referred by Linnæus to his *Scitamineæ*; with *Heliconia* and *Ravenala*, Schreber's *Urania*, both nearly akin to *Musa*.

20. *Cannæ* are the *Scitamineæ* of Linnæus, ord. 8.

21. *Orchideæ* are his *Orchideæ*, ord. 7.

22. *Hydrocharides* are an assemblage of water plants, having little else in common. *Valisneria*, *Hydrocharis*, and *Stratiotes*, make a sort of appendix to the Linnæan *Palmæ*. For *Nymphæa* and *Nelumbium* (now called *Cyamus*), see our remarks on the 11th, 54th, and 27th, of the Linnæan orders. *Trapa*, *Proserpinaca* and *Pistia* close the list. Linnæus has the two last in his *Inundatæ*, ord. 15.

CLASS 5.

23. *Aristolochiæ* compose the end of the Linnæan *Sarmentaceæ*, but were afterwards removed to the *Rhœadææ*, ord. 27. They are surely beat by themselves, and constitute a very natural order, not detected by Linnæus.

CLASS 6.

24. *Elæagni* consist of Linnæan *Calycifloræ*, ord. 16, with various genera besides, referred to almost as many different orders by Linnæus, so that here the two systems exhibit but little analogy, nor is this one of Jussieu's best orders.

25. *Thymelææ*, *Vepreculæ* of Linnæus, ord. 31, (the *Daphne* tribe,) are very clearly defined.

26. *Proteæ*, an order scarcely known to Linnæus, though an extremely natural one. It makes a part of his *Aggregatæ*, ord. 48, in the establishing of which, a sort of artificial character, expressed in the name, has led him into unnatural combinations; a fault which Linnæus, more than any other writer in this department, has generally avoided.

27. *Lauri*, a very good order, not perceived by Linnæus. We cannot say much for the genera of *Myristica* and *Hernandia* annexed to it.

28. *Polygonææ* make a part of the Linnæan *Holeraceæ*, ord. 12.

29. *Atriplices*, another portion of the same

CLASS 7.

30. *Amaranthi*, these, originally a part of the *Mis-*

cellanææ, ord. 54, were also referred subsequently to the *Holeraceæ*. They are supposed to differ from Jussieu's two preceding orders, in having the stamens inserted into the receptacle, not into the calyx, hence forming a separate class. But there is no instance perhaps in which his system proves more artificial, and at the same time more uncertain in character. Mr Brown has anticipated the latter part of our remark in his *Prodromus*, 413, nor could it fail to strike any one who ever considered the subject.

Linnæus has no order analogous to these. Yet he has left manuscript indications of his perceiving the affinity of some of the genera.

31. *Plantagines*.
32. *Nyctagines*.
33. *Plumbagines*.

CLASS 8.

34. *Lysimachiæ* embrace many of the *Rotaceæ*, ord. 20, and *Preciæ*, ord. 21. *Globularia*, *Tozzia*, *Samolus*, *Utricularia*, *Pinguicula*, and *Mengyanthes*, subjoined as allies, not indeed without many doubts; appear to us greatly misplaced. The first of these is allowed to indicate an order not yet defined.

35. *Pediculares*, an important order, which Jussieu has well selected out of the Linnæan *Personatæ*, ord. 40; though we are somewhat startled at finding *Polygala* at the head of the list, which Linnæus, not more happily perhaps, ranges with his *Lomentaceæ*, ord. 33.

36. *Acanthi* are a few more of the *Personatæ*.

37. *Jasminææ* are precisely the Linnæan *Sepiariæ*, ord. 44.

38. *Vitices* consist of more *Personatæ*, separated with judgment from the rest; Linnæus having, in the contemplation of his 40th order, been again seduced by artificial principles, and by the usage perhaps of considering his *Didynamia Angiospermia* as of itself a natural order.

39. *Labiataæ* are precisely the *Verticillatæ*, ord. 42, of Linnæus, a tribe about which no two systematics could differ, and which it is one of the greatest evils of the artificial sexual system to be obliged to disjoin.

40. *Scrophulariæ* are more of the *Personatæ*, ranged here, after the *Labiataæ*, on account of the close affinity of several of them to the next order. But it must be confessed that the *Labiataæ* thus come awkwardly between what are strictly akin, and that this intrusion is a great flaw in the natural character of the system; inasmuch that we should gladly remove them to another place, between the *Solanææ* and *Borraginææ* hereafter mentioned.

41. *Solanææ* consist principally of *Luridæ*, ord. 28, to which a few more of the *Personatæ* are subjoined as allies. It is remarkable that, in his characters of the seven last-mentioned orders, Jussieu admits those marks, derived from the stamens, on which the classes of the Linnæan artificial system depend. The intelligent reader will easily observe, that the distinctions thence deduced, form a leading principle in the respective positions of these orders and the following. This is the more curious, as the French school is entirely obliged to Linnæus for bringing the organs in question into notice, for the purposes of arrangement, Tournefort and his pupils having never adverted to them.

Botany.

Botany.

42. *Borraginæ*, these are the *Asperifoliæ*, ord. 41, of Linnæus, surely better placed by him between his *Personatæ* and *Verticillatæ*. The order is very natural, and Jussieu's criticism upon it excellent.

43. *Convolvuli*
44. *Polemonia*
45. *Bignoniæ*

To these Linnæus has no analogous order, most of the genera in the two first being referred to his *Campanacæ*, order 29, and of the last to *Personatæ*.

In this instance we cannot but admit the superiority of Jussieu's arrangement.

46. *Gentianæ*—a very natural and distinct order, confounded by Linnæus with his *Rotacæ*, ord. 20, to which it has but little relationship.

47. *Apocinæ*—precisely the Linnæan *Contortæ*, ord. 30, a most distinct and curious tribe, though both the great authors, of whom we are treating, have been mistaken in referring hither a genus or two, which do not at all belong to it. See our remarks on this 30th order of Linnæus.

48. *Sapotæ*—an order of which Linnæus had no perception. Some of its genera find a place among his *Dumosæ*, ord. 43, an assemblage which, he ingeniously confesses, did not satisfy himself.

CLASS 9.

49. *Guaiacana*. Of this also Linnæus had no distinct ideas. Some of the genera he places with his *Bicornes*, ord. 18. Yet some pupils of Jussieu have refined upon this and the last, and he himself has founded an order of *Ebenacæ*, upon the first section of his *Guaiacana*; see Brown's *Prodromus*, 524.

50. *Rhododendra*.51. *Ericæ*.

These two collectively answer to the *Bicornes*, ord. 18, of Linnæus, an error or two, on either part, excepted.

52. *Campanulacæ* nearly correspond with the genuine *Campanacæ*, ord. 29, of Linnæus, from whence, as we have before hinted, *Convolvulus* and its allies are well separated in the system of Jussieu.

CLASS 10.

53. *Cichoracæ*, a most natural order, the *Compositæ semiflosculosæ*, ord. 49. sect. 2. of Linnæus. The essential character of this 10th class is adopted from the artificial system of Linnæus, the united anthers, *antheræ connatæ*; a circumstance never adverted to by any systematic writer before him. Yet it is not absolutely without exception; witness the genera of *Kuhnia*, *Sigesbeckia* and *Tussilago*.

54. *Cinarocephalæ* answer nearly, at least in principle, to the *Compositæ capitatæ*, ord. 49. sect. 1.

55. *Corymbiferæ* embrace all the remaining *Compositæ*, including the last section of that order, *nucamentacæ*, some of which Jussieu terms *Corymbiferæ anomalæ*; such as *Iva*, *Parthenium*, *Ambrosia*, *Xanthium*, and even *Nephtelium*.

CLASS 11. Distinguished from the last Class, only by having separate anthers.

56. *Dipsacæ* consist of some of the Linnæan *Aggregatæ*, ord. 48. See our remark under Jussieu's 26th order. There is ample room for speculation on the affinities and distinctions between these *Dipsacæ*, the *Proteæ*, ord. 26th, and the whole of Jussieu's 10th class last mentioned. Their contemplation involves questions at any time sufficient to excite a botanical

war—such as, what belongs to the inflorescence, and what to the flower? what is a calyx, and what the crown of the seed? what is superior and what inferior insertion? what a simple and what a compound flower?

57. *Rubiaceæ*, a vast and important order, composed, not only of the Linnæan *Stellatæ*, ord. 47, but also of numerous tribes of shrubby plants, very few of which had been referred to the *Stellatæ*, and many of them had not fallen under the notice of Linnæus at all. Jussieu shines in the elucidation of this order, and has well indicated certain characters in the habit, especially that of the intrafoliaceous sheathing stipulas.

58. *Caprifoliæ* are nearly equivalent to the 4th, or last, section of Linnæus's *Aggregatæ*, ord. 48, except *Viburnum* and its allies, with *Cornus* and *Hedera*; the former placed, without much reason, in the Linnæan *Dumosæ*; *Cornus* with the *Stellatæ*; and *Hedera* in *Hederaceæ*, ord. 46, nearly agreeing with Jussieu's 59th next mentioned. *Cornus* and *Hedera*, being both allowed to be polypetalous, really belong to the next class, as the author could not but perceive. Indeed Jussieu's 11th and 12th classes, however distinct in theory, naturally slide into each other.

CLASS 12.

59. *Araliæ* answer to the Linnæan *Hederaceæ*, ord. 46, *Hedera*, *Vitis* and *Cissus* excepted, which Linnæus himself appears to have had some idea of removing from *Panax*, *Aralia*, &c.

60. *Umbelliferæ* of course correspond with the *Umbellatæ*, ord. 45, of Linnæus, one of the most natural of the whole.

CLASS 13.

61. *Ranunculacæ* answer to the Linnæan *Multifloræ*, ord. 26. The authors differ in the denomination of the parts of the flower, Jussieu's *calyx* being sometimes the *corolla*, and his *petals* the *nectaries*, of Linnæus.

62. *Papaveracæ* are, except *Hypecoum* and *Feraria*, Linnæan *Rhocadeæ*, ord. 27.

63. *Cruciferæ* the Linnæan *Siliquosæ*, ord. 39, so natural an order, that we can scarcely say to which it is next akin.

64. *Capparides* mostly Linnæan *Putamineæ*, ord. 25, with some very anomalous genera subjoined as related thereto, *Reseda*, *Drosera* and *Parnassia*, not without great and well-founded doubts of the author.

65. *Sapindi*
66. *Aceræ*
67. *Malpighiæ*

{ These are comprehended in two of the sections of the *Trihilatæ*, ord. 25, of Linnæus.

68. *Hypericæ*. *Ascyrum* and *Hypericum*, the only real genera of this order, are, with *Cistus*, subjoined to the Linnæan *Rotacæ*, ord. 20; certainly with no very evident reason.

69. *Guttiferæ* constitute a well-marked order, to which Linnæus has nothing analogous. Most of the genera that compose it, are either left by him unarranged, or considered as of dubious affinity to any others. Indeed they are generally tropical trees, respecting which he had but slight information.

70. *Aurantia*. Of this likewise Linnæus seems to have formed no idea, since he refers *Citrus* to his *Bicornes*, and leaves *Limonia* undetermined. *Camelia* and *Thea*, subjoined by Jussieu, with some

Botany.

Botany.

other genera, to this order, as connecting it with the next, appear to us of very dubious affinity to the *Aurantia*; nor are they much better annexed by Linnæus to his *Columnifera*, ord. 37.

71. *Meliæ* constitute a good order, comprehended, not very judiciously, under the Linnæan *Tribilata*, ord. 23, above mentioned.

72. *Vites*, consisting only of *Cissus* and *Vitis*, we have already mentioned, ord. 59, as included amongst the *Hederaceæ*, ord. 46, of Linnæus.

73. *Gerania* make a part of the Linnæan *Grinales*, ord. 14, but *Tropæolum*, a puzzling genus, which Jussieu labours to prove in many respects related to them, is referred by Linnæus, as reasonably perhaps, to his *Tribilata*.

74. *Malvaceæ* are almost exactly analogous to the *Columnifera*, ord. 37.

75. *Magnoliæ* form an order certainly as little connected with the preceding as any two could be in the most artificial system. See the following.

76. *Anonæ*. The leading genera of this and the *Magnoliæ* compose the Linnæan *Coadunata*, ord. 52.

77. *Menisperma* are referred by Linnæus to his *Sarmentaceæ*, ord. 11, by their habit more than any just character.

78. *Berberides* constitute a curious order, though liable to some exceptions, of which its author was aware. It entirely escaped the penetration of Linnæus.

79. *Tiliaceæ* a good order, likewise overlooked by him, or partly confounded with his *Columnifera*, to which it betrays some affinity.

80. *Cisti*. *Cistus*, which makes this order, is placed by Linnæus, after *Hypericum*, at the end of his *Rotaceæ*, ord. 20. The reader may wonder to find *Viola* considered as related to *Cistus*, or at least to those species which Jussieu separates therefrom, by an incorrect character, and a faulty name, *Helianthemum*. He attributes to these a capsule of one cell; but one of them at least, *Cistus thymifolius*, has three cells. *Viola*, an anomalous genus, is ranged by Linnæus at the end of his *Campanaceæ*, ord. 29, with which it seems to have more points of agreement.

81. *Rutaceæ*. This is a very natural, and now become a very extensive order, of which the genuine idea is confined to Jussieu's second section, and likewise to the second section of Linnæus's *Multisiliqua*, ord. 26. The plants which compose it have alternate leaves, without stipules; their herbage abounding with aromatic acrid essential oil, lodged in pellucid cells, as in Jussieu's *Aurantia*, ord. 70. Calyx four or five-cleft. Petals four or five, alternate therewith. Stamens usually twice as many as the petals, distinguished by something elaborate or peculiar in their structure, by which the genera are often well defined. Germs lobed. Capsule mostly of four or five cells, each lined with a bivalve elastic tunic, containing one or two polished seeds. *Diosma* and *Empleurum*, subjoined as akin to *Rutaceæ*, are genuine specimens of the order, though the latter has a capsule deprived of three or four of its lobes or cells, and wants petals. *Melanthus* has no business here. It ranks with the Linnæan *Corydales*, ord. 24, much more properly,

though a very puzzling genus. The students at Paris, in our time, used to amuse themselves with the idea, that the Professor would not allow this fine plant a place in the garden, because he knew not where to class it in his system.

82. *Caryophylleæ* are exactly analogous, except a few rather doubtful genera at the end, to the similarly named 22d order of Linnæus. But between this very natural tribe and the last, *Rutaceæ*, there is a hiatus valde defendendus, as to any natural affinity; the present order being much more related, as Jussieu candidly indicates, to the *Amaranthi*, ord. 30, and proving that the presence or absence of a corolla, is no more infallible than any other character, for a general principle of arrangement.

CLASS 14.

83. *Sempervivæ* are the second section of Linnæus's *Succulentæ*, ord. 13.

84. *Saxifragæ* are chiefly the fourth section of the same.

85. *Cacti* consist merely of *Ribes* and *Cactus*, as artificial a combination as most in the sexual system itself. The former Linnæus ranks with his *Pomaceæ*, ord. 36; the latter is the first genus of his *Succulentæ*.

86. *Portulacæ* are selected out of the first and third sections of the *Succulentæ*.

87. *Ficoideæ* consist of more of the same.

In this part of their respective systems, we find it more difficult than usual to follow the ideas of the learned authors. Habit seems to have guided Linnæus; but Jussieu tracing, in his last five orders, nearly the same affinities, has somewhat strained his technical characters to confirm them.

88. *Onagræ* accord, in the main, with the Linnæan *Calycanthemæ*, ord. 17. They well connect the five preceding orders with the following. *Bacchæ* belongs to the *Myrti*.

89. *Myrti* are the Linnæan *Hesperideæ*, a very natural family, much amplified by Jussieu from recent discoveries.

90. *Melastomæ* are not distinguished by Linnæus from his *Calycanthemæ*.

91. *Salicariæ* are in the same predicament. Jussieu has considerably the advantage here.

92. *Rosaceæ* embrace the *Senticoceæ*, ord. 35, and *Pomaceæ*, ord. 36, of Linnæus, nor can there be a more natural assemblage.

93. *Leguminosæ* comprehend, in like manner, two Linnæan orders, *Papilionaceæ*, the 32d, and *Lamellaceæ*, the 33d, which we should be disposed to keep distinct, however nearly they must be considered as akin. The Linnæan characters, though often termed artificial, serve Jussieu for the distinctions of his sections.

94. *Terebinthaceæ*, an order learnedly sketched out, rather than completed, by Jussieu, which seems entirely to have escaped the perception of Linnæus. It brings together many things which he either did not pretend to arrange, or which clogged some of his orders.

95. *Rhamni* constitute a very natural order, of which the Linnæan *Dumosæ*, ord. 43, are but a sketch, confessedly imperfect.

Botany. CLASS 15.

96. *Euphorbiæ* are Linnæan *Tricocææ*, ord. 38.
 97. *Cucurbitaceæ* agree, in name as well as idea, with the 34th of the Linnæan orders.
 98. *Urticæ* are nearly analogous to *Scabridæ*, ord. 53, except that *Piper* is mentioned as related to them, instead of being referred to a monocotyledonous order with *Arum*, *Pothos*, *Acorus*, &c. Yet its germination is rather hinted at than determined, nor does any thing positive seem to be known on that subject.
 99. *Amentaceæ* are mostly what Linnæus has, under the same appellation, in his 50th order.
 100. *Coniferae* are his 51st, bearing the same name.

Conclusion. As Linnæus enumerates, at the end of his Natural Orders, 116 genera, which he could not then satisfactorily refer to any one of them; so Jussieu, at the conclusion of his System, reckons up 137, which, as we have already observed, he denominates *Plantæ incertæ sedis*. These are disposed synoptically, by their petals, germens and styles. It is remarkable how nearly, allowing for new discoveries, Jussieu accords with Linnæus in the number of such genera. These lists have both been greatly diminished by subsequent consideration, or more complete information.

The attention of botanists, first directed by Gærtner, to the minute and curious diversities of structure in the parts of the seed, has greatly assisted Jussieu and his followers in correcting and improving the details of his system. Hence he has been led to favour the world with several essays on particular families, or orders, in the *Annales du Muséum d'Hist. Nat.*, some of which have appeared in the very valuable *Annals of Botany*, published by Dr Sims and Mr König. In these, several of the difficulties, which originally embarrassed their author, are lessened or removed, but on these it is not our purpose to enter. A new edition of Jussieu's *Genera Plantarum*, which has long been preparing, cannot fail to prove almost a new work; more valuable perhaps for the abundant information which it must afford, concerning the characters and affinities of particular genera, than for any thing concerning a general natural system, to perfect which the scientific world has not, as yet, sufficient materials.

As we cannot here undertake to detail Jussieu's own corrections or improvements of his system, neither can we explain what has been attempted, with the same design, by the late ingenious M. Ventenat, or by those excellent living botanists, M. De Candolle, or Mr Brown. We shall only observe, that Ventenat, too servile to Jussieu, explicitly contends for the natural method of classification, as superseding the artificial one, and that he aims at proving this to have been the intention of Linnæus. Yet nothing can be more positive to the contrary than the remarks of the latter, in the preface to his *Ordines Naturales* at the end of his *Genera Plantarum*. He there declares that his "artificial method is alone of use to ascertain plants, it being scarcely possible to find a key to the natural one." "Natural orders," he continues, "serve to teach the nature of plants, artificial ones to distin-

guish one plant from another." If it be said that Jussieu, having invented a key, or a set of distinctive characters, to his orders, has removed this objection, we would ask, What becomes of his doubtful genera, as numerous as those of Linnæus? or moreover, How is any student, using his system analytically, to make out a single unknown plant? That the pupils of Jussieu have ever been aware of this, the writer of the present essay very well knows. He has always found them, in conversation, aiming compliments at their illustrious master, by contending for the great difficulty and uncertainty of the Linnæan artificial system; by which palpable absurdity they betrayed their secret opinion of Jussieu's. On the other hand, the intelligent and candid De Candolle, adopting the just opinion of Linnæus, that plants are allied to each other rather in the form of a table, or map, than in a linear series, actually proposes such a series as necessarily artificial, in his *Theorie Elementaire de Botanique*, 213. Concerning the precise disposition of the genera in this series, we believe scarcely two botanists would agree; nor might their contentions be unprofitable; but they would never teach, either a tyro or an adept, to ascertain an unknown plant. We will venture to go further, and to declare our opinion, founded on long observation, that botanists who are thus perpetually intent on the abstract theory of classification, scarcely attain any excellence in the technical discrimination, or definition, of what are really founded in nature, the species or genera of the vegetable kingdom. Those err greatly who seek to improve the system of Jussieu, or any other, by refining too much on his distinctions, and subdividing his orders; than which nothing is more easy. Judgment and extensive knowledge are displayed in tracing out the most essential points of agreement in natural objects; not in exalting into unmerited importance the most minute differences. Hence the very conciseness of Linnæus, gives perspicuity to his descriptions and definitions. These afford the most instructive study, whatever mode of classification we may think most convenient.

The French school has been much flattered, by our able countryman Mr Brown, having classed his *Prodromus* of the New Holland plants after the method of Jussieu; and many a botanist enjoys this national triumph who is certainly not competent to appreciate the merit of that work. The plants of so novel a country could not, at this time of day, have been presented, with so much advantage, to a philosophical botanist, as in some natural arrangement, however imperfect; nor will many students travel thither, to make them out by methodical investigation. The touchstone of our learned friend's book however will be the *Plantæ incertæ sedis*, nor can it be judged, as to the merit of the system employed, till it arrives at that conclusion. He himself will surely not reckon it complete without a Linnæan index,

"To give the precious metal sterling weight."

(J. J.)

Botany
Bay
Bougainville.

Bougainville.

BOTANY BAY, the name of a British settlement in New Holland, for the history of which, see **HOLLAND, NEW**, in the *Encyclopædia*, and the same head in this Supplement, for an account of its present state.

BOUGAINVILLE (**LOUIS ANTOINE DE**), a celebrated Circumnavigator, was born in Paris in 1729. His father was a Notary, and one of the Sheriffs of the city of Paris. The parents of young Bougainville wished him to practise as a Lawyer, and, for this purpose, he was received Advocate in the Parliament of Paris; but his own inclination was averse to the profession, and he entered into the army in the corps of musketeers.

He associated much with Clairaut and D'Alembert, who happened to live in his neighbourhood, and from this intercourse he derived his knowledge of Algebra and Fluxions. At the age of twenty-five he published his treatise on the *Integral Calculus*, intended as a supplement and continuation of L'Hospital's treatise *Des infiniment petits*. Bougainville, in his preface, declares, that all he has done in this work, is to place, in a systematic order, the formulæ of different mathematicians.

He was raised to the rank of Major in the Picardy regiment. He went to London as secretary to the French embassy, and was chosen a Member of the Royal Society. In 1756, he went to Canada as Captain of dragoons, and having distinguished himself in the war against England, was rewarded by the cross of the order of St Louis.

After the peace, the French government having conceived the project of planting a colony on the Falkland Islands, Bougainville undertook to begin this establishment at his own expence. The Falkland Islands, to which Bougainville gave the name of Malouines (that is, St Malo Islands), are in 51° south latitude, and 10° of longitude to the east of the meridian of Cape Horn. Fish is abundant on their shores, and there is peat or turf for fuel, but no wood. Bougainville began the settlement by landing some families of French Canadians. The number of settlers was increased afterwards to 150.

This colony excited the jealousy of the Spanish government; and the government of France agreed that it should be given up to the Spaniards, the Spanish government undertaking to indemnify Bougainville for the expence he had been at in forming the establishment.

As a consolation to Bougainville for the loss of his colony, he was appointed to command the Frigate *La Boudeuse* of 26 eight pounders, and the transport *L'Etoile*, to go on a voyage of discovery round the world. He took with him Commerçon as Naturalist, and Verron as Astronomer.

This was the first voyage round the world performed by the French. Since the first circumnavigation by Magellan under the Spanish Government in 1519, and that of Drake under Queen Elizabeth in 1577, eleven other circumnavigations of the world had been performed, part of them by the Dutch, and part by the English, and also several voyages of discovery had been made in the Pacific Ocean, without circumnavigation.

The expedition commanded by Bougainville was

at Buenos Ayres at the time of the seizure of the Jesuits of Paraguay. The missions on the river Araguay, in the province of Paraguay, contained a population of 800,000 Indians, divided into parishes, and governed solely by the Jesuit parish priests. No other Europeans but the Jesuits were admitted into the country, in order that the work of conversion might not be frustrated by bad example. The produce of the labour of the Indians was delivered into the hands of the Jesuits, who furnished them with food and clothing. For this purpose the Jesuits had warehouses filled with European and American merchandise, and also a number of slaves. They had schools for instructing the Indians in music, painting, and other arts. The Spanish government having determined on the suppression of the Jesuits, took every precaution to prevent their being informed of the intended measure; and they were arrested and sent to Europe without any attempt at resistance on their part.

Bougainville passed the Straits of Magellan, and anchored for a week at Otaheite, where the English navigator Wallis had touched eight months before. A young man of Otaheite joined the expedition, and was taken to Paris, where he staid thirteen months. On his way back to his native country he died of the small-pox.

The numerous rocks and other dangers made Bougainville turn off to the north-east, and prevented him from continuing a westerly course, so as to pass through the channel which separates New Holland from New Guinea. These two Islands, in his general chart, are laid down as forming one, although he possessed some information of the existence of the channel. Two years after, namely in 1770, Captain Cook sailed through this channel, so dangerous by its coral reefs.

The expedition having now crossed all the meridians of the Pacific Ocean, and suffering from the scurvy in consequence of scarcity of food, came to anchor in the Gulf of Cajeli, a settlement of the Dutch East India Company in the agreeable Island of Borou, one of the Moluccas. The Governor liberally supplied the wants of the expedition. He lived splendidly in a house built in the Chinese style, and judiciously adapted to the warmth of the climate; his wife and daughters wore the Chinese dress. "Sa maison étoit la notre," says Bougainville; "à toute heure on y trouvoit à boire et à manger, et ce genre de politesse en vaut bien un autre pour qui surtout se ressentoit encore de la famine." It was the beginning of September, and the expedition shortened their stay at Borou, in order to take advantage of the latter part of the easterly monsoon, which carried them to Batavia; from thence they proceeded to the Isle of France. Commerçon remained at the Isle of France, that he might from thence proceed to examine the botany of Madagascar, as did Verron, for the purpose of observing the transit of Venus.

In 1769, the expedition arrived at St Malo, after a voyage of two years and four months, with the loss of only seven men out of upwards of 200.

Bougainville's account of the voyage is written with simplicity, and in a temper which inclined him

Bougainville
|
Bouguer.

to view objects on the humorous side. His courage, the good humour with which he maintained subordination, and his attention to the health and comforts of the crew, are everywhere conspicuous.

The art of making astronomical observations at sea was not so much improved as it is now, and especially the methods for ascertaining the longitude were very defective. In consequence of this, Bougainville's charts are erroneous, and particularly in the longitudes. Neither did he remain long enough in any place to make particular surveys.

Bougainville's life was an active one, so that little of it could be devoted to study. On his return to France, his time was passed in the company of the highest circles in Paris. He had the command of a ship under De Grasse and D'Estaing; and, in April 1781, when the French fleet was beaten, he rallied some of the beaten ships, and brought them into St Eustachio. After the peace, by which the independence of the United States of America was secured, Bougainville returned to Paris. The Academy of Sciences was at that time composed of pensioned members, and of associates who had no salary; Bougainville solicited and obtained the place of Associate of the Academy.

He had a project of making a voyage of discovery towards the north pole. As this did not meet with support from the French Government, he sent his plan to Admiral Phipps; Phipps, however, followed a different course from that proposed by Bougainville, but he only got to the 80th degree of north latitude.

Recourse was had to Bougainville in order to repress the mutinous disposition of the sailors in the French Navy, before the breaking out of the Revolution; but his efforts were ineffectual. He had the rank of Vice-Admiral in 1791. In 1792, he escaped almost miraculously from the massacres of Paris, and went to live on his estate in Normandy. He was much attached to the Government, which was then falling. He lived on his estate for some time; it was the only part of his fortune that the Revolution had left him. He was chosen a Member of the Institute at its first formation, and, in consequence, returned to reside in Paris. He succeeded Borda as Member of the Board of Longitude. In his old age, under the government of Bonaparte, he enjoyed the dignity of Senator, was created a Count, and Member of the Legion of Honour.

He retained his good-humoured liveliness and his mental faculties to the last, and died in 1811, aged 82.

He was married, and had three sons who served in the French army. He was always eager to promote science; and he conducted himself during the Revolution, in such a manner as to obtain the respect of all parties. His eulogy is written by Delambre in the *Memoirs of the Institute*. (x.)

BOUGUER (PERRA), an eminent French Mathematician, was born in 1698. His father was King's Professor of Hydrography at Croisic in Lower Brittany, one of the best Hydrographers of his time, and author of an excellent Treatise on Navigation. Young Bouguer was bred to Mathematics from his

infancy, and made rapid progress in that science. At an early age he was appointed to succeed his father in the chair of Professor of Hydrography, after having undergone a strict examination in Mathematics, so as completely to satisfy his examiners. In 1727, he gained the prize given by the Academy of Sciences of Paris, for his paper *On the best Manner of forming and distributing the Masts of Ships*. He got two other prizes from the Academy in the course of four years; the one was bestowed on him for his Dissertation *On the best Method of observing the Altitude of Stars at Sea*; the other, for his paper *On the best Method of observing the Variation of the Compass at Sea*. These papers are published in the *Prix de l'Academie des Sciences*. In 1729, he published a work entitled *Essai d'Optique sur la Gradation de la Lumière*; the object of which is to define the quantity of light which is lost by passing through a given extent of the atmosphere. He finds the light of the sun to be 300 times more intense than that of the moon.

He was soon after made Professor of Hydrography at Havre, whereby he had the advantage of being nearer Paris than before; and he was chosen associate Geometer of the Academy of Sciences, a place which did not require residence in Paris. In this place he was the successor of Maupertuis. Afterwards, he was promoted in the Academy to the place of pensioned Astronomer, and came to reside in Paris.

It was resolved in France to send an expedition to South America for the purpose of measuring a degree of the meridian near the equator. From that measurement, compared with the length of a degree of the meridian in other latitudes, the deviation from sphericity in the figure of the earth might be known. The Academy made choice of four of its members to proceed on this voyage; they were Godin, Bouguer, and de la Condamine, for the geodetical operation, and the younger Jussieu for observations in Natural History. Bouguer and his fellow-travellers sailed from La Rochelle in 1735, and it was ten years before he returned to France. The account of his operations during the expedition is given by him in the *Memoirs of the Academy of Sciences*, 1744, and in a separate work, entitled *La Figure de la Terre déterminée par les observations de MM. Bouguer et de la Condamine*. There is likewise an account of this expedition published by Don George Juan and Don Antonio de Ulloa, two scientific naval officers, who accompanied the expedition by order of the Spanish Government. The length of a portion of the meridian was measured on the ground by means of a base and a set of triangles. Then by observing the altitude of the ϵ of Orion which passed near the zenith, simultaneously at the two ends of the meridian line that had been measured, that line was found to contain $3^{\circ} 7'$ of latitude. A star near the zenith was employed, to the end that the observation might not be affected by refraction; ϵ of Orion passed the meridian in the zenith near the middle of the line measured, so that the distance of that star south of the zenith of the northern extremity of the line was $1^{\circ} 25' 46''$; and its distance

Bouguer: north of the zenith of the southern extremity of the line was $1^{\circ} 41' 13''$; the sum of these two numbers making $3^{\circ} 7'$. The altitude was taken by zenith sectors of a long radius. The ground on which these operations were performed was elevated 12,000 feet above the level of the sea, and 4200 feet above the neighbouring city of Quito, and situate in a plain extending from north to south, between the two ridges of the Cordillera. The northern extremity of the arc was on the equator. The length of the degree resulting was 56,767 toises; but this was the degree of a curve circumscribed round the earth at the height of 12,000 feet above the level of the sea; and the length of the degree at the level of the sea deduced from this, with some other corrections, is 56,753 toises. This length of the degree of the meridian at the equator was compared with the degree of the meridian measured in France, with the degree measured in Lapland, and with the degree of longitude deduced in the south of France. From this comparison it was concluded, that the equatorial diameter of the earth is to the polar diameter as 179 to 178, and that the equatorial radius of the earth was about eight leagues longer than the polar. Since the time of Bouguer, degrees have been measured in different climates, with more accurate instruments than he possessed; but the precise proportion of the equatorial and polar diameters of the earth is not yet finally ascertained. Bouguer makes the excess of the equatorial diameter above the polar to be $\frac{1}{13}$; Sir Isaac Newton made it $\frac{1}{13}$; Laplace, calculating from the lunar motion, $\frac{1}{13}$; Melanderhielm and Svanberg, from a degree measured anew in Lapland in 1783, compared with the degree measured in the province of Quito, $\frac{1}{13}$. Bouguer found the seconds pendulum $\frac{16}{100}$ of a line shorter at the summit of Pichincha than at the level of the sea; that is, the force of gravity was less by one 1200th part at that elevation.

He made some observations on the limit of perpetual snow, a subject which has been elucidated, since his time, by the researches of Humboldt, Von Buch, Wahlenberg, and others. At the equator, the limit of perpetual snow is at 14,760 feet above the sea; a height equal to that of Mont Blanc. In Mexico, in the latitude of $19^{\circ} 20'$, it is at 13,800 feet, according to Humboldt. In latitude $28^{\circ} 15'$, where the Peak of Teneriffe is situate, it is supposed to be 11,700 feet: the Peak is only 11,454 feet, and has no perennial snow. On Etna, in latitude $37^{\circ} 30'$, the edge of the perennial snow is at the height of 9000 feet. On Mount Caucasus, in latitude $42^{\circ} 30'$, the limit is at 9900 feet; whilst on the Pyrenees, in latitude $42^{\circ} 45'$, it descends to 8400 above the sea; and on the Swiss Alps, in latitude 46° , to 8220 feet. In Iceland, in latitude 65° , the edge of the perennial snow is at the perpendicular height of 2892 feet from the sea. In Lapland, in latitude 67° , where the summers are warmer than in Iceland, though the winters are colder, the perennial snow does not descend so low, attaining only to 3800 French feet from the sea, as Von Buch and Wahlenberg ascertained by barometrical observations. When the latitudes are the same, a solitary mountain will have the edge of the perennial snow

VOL. II. PART II.

higher than a mountain surrounded by others, on account of the warm winds from the neighbouring plains. A mountain in an inland situation will have the border of the perennial snow higher than a mountain in the same latitude, and situated in an island; the summers which reduce the limits of the snow being warmer in the inland situation. When the mass of perennial snow is large, glaciers are formed, which descend below the limit of perennial snow. Chimborazo has 5400 feet of its height covered with perpetual snow, according to Humboldt. Bouguer thought he could perceive that the clouds do not ascend higher than 2400 feet above the summit of Chimborazo. If there were mountains whose height reached beyond the greatest height to which the clouds attain, all the part of the mountain above the region of the clouds would be free from snow, although exposed to intense cold. On Bouguer's supposition of the height to which the clouds ascend, the upper limit of snow at Chimborazo would be at the height of 22,200 feet above the sea; and the distance between the upper limit of snow and the lower limit would be there about 7800 feet.

Bouguer, whilst he was at the equator, made observations to ascertain the obliquity of the ecliptic, which he found to be $23^{\circ} 28' 28''$. He also made some experiments on the deviation of the plumb-line from the vertical, occasioned by the attraction of a neighbouring mountain, a phenomenon afterwards investigated by Dr Maskelyne, on the mountain Schehallien.

The number of Bouguer's papers contained in the printed Memoirs of the Academy of Sciences, is a proof of the assiduity with which he performed his duty in the Academy. His *Heliumeter* is described in the Memoirs of the Academy for 1748. It is an object-glass Micrometer, and its essential parts consist of an astronomical dioptric Telescope, with two object-glasses of the same focal length, placed side by side. When this instrument is directed to the sun, each object-glass gives an image of that luminary; and the object-glasses are so placed that the limbs of the two images touch when the diameter of the sun is greatest, and when the diameter is less, there is an interval between the limbs of the two images.

Some experimenters maintained that the plumb-line had a diurnal oscillation; Bouguer showed that it remains at rest. He employed, for this purpose, a Telescope attached to the end of a chain 187 feet long, suspended within the dome of the church of the Hospital of Invalids at Paris; the Telescope was directed to a distant mark, so that any motion in this long pendulous system might be seen by the deviation of the wires of the Telescope from the mark. The particulars of this experiment are to be found in the *Mém. de l'Académie des Sciences*, 1754.

In the volume for 1739 and 1749, there are papers of his on the astronomical refraction in the torrid zone, particularly in cases where the star is seen at more than 90° from the zenith, in consequence of the observer being in a high situation. In the volume for 1747, he proposed a log of a new construction for measuring a ship's way.

In the same collection, there are papers of his on

3 H

Bouguer
Boulton.

the length of the pendulum, on the form of the *prova* which suffers least resistance in passing through the water, and on a variety of other subjects. He bestowed great pains on his works, and his health at length became impaired by a sedentary life, and too constant application to scientific pursuits. He died in 1758, aged sixty. His disposition was naturally mild, and the dissensions that arose between him and his fellow traveller de la Condamine caused him great vexation. He was impressed, from his earliest years, with a conviction of the truths of Christianity. By economy he had acquired a moderate fortune, a part of which he bequeathed to the poor. The following is a list of his principal works:

Traité d'Optique sur la Gradation de la lumière, 1729 and 1760.

Entretiens sur la cause de l'Inclinaison des orbites des Planètes, 1734; another edition in 1749.

Traité de navire, de sa construction, et de ses mouvemens, 1746, 4to.

La Figure de la terre déterminée, par les Observations de Mess. Bouguer, et de la Condamine, envoyés par ordre du roy au Perou; Par M. Bouguer, 1749, 4to.

Nouveau Traité de Navigation, contenant la Theorie et la Pratique du Pilotage, 1753. A new edition by de la Caille. 1761.

Solution des Principaux Problemes sur la Manœuvre des Vaisseaux, 1757.

Operations faites pour la Verification du degré du meridien entre Paris et Amiens; Par Mess. Bouguer, Camus, Cassini, et Pingré, 1757.

After his return from South America, he was Editor of the *Journal des Savans*. Some of his papers in the *Memoirs of the Academy of Sciences* have been mentioned in this article; his *Eloge* is contained in the volume for 1758. (v.)

BOULTON (MATTHEW), a Manufacturer and practical Engineer of great celebrity; son of Matthew Boulton, by his wife Christian, daughter of Mr Peers of Chester; was born at Birmingham the 14th of September 1728, and died in August 1809.

He was educated at a neighbouring grammar school, kept by Mr Ansted of Deritend, and was called early into active life upon the death of his father in 1745. The various processes by which the powers of the human mind have given facility to the artist in rendering the different forms of matter obedient to his command, afforded ample scope for the exercise of his inventive faculties, in improving the manufactures of his native place. His first attempt was a new mode of inlaying steel; and he succeeded in obtaining a considerable demand for the products of his manufactory, which were principally exported to the Continent, and not uncommonly reimported for domestic use, as of foreign manufacture.

In 1762, his fortune being already considerable, he purchased a tract of barren heath in the neighbourhood of Birmingham, with a single house on it, and there founded, at the expence of L. 9000, the manufactory which has been so flourishing, and so well known under the name of Soho. His workmen

were at first principally employed in the imitation of *Boulton* or moulu, and in copying oil paintings with great accuracy, by means of a mechanical process which was invented by a Mr Egginton, who afterwards distinguished himself by various works in stained glass. Mr Boulton, finding the force of horses inadequate to the various purposes of his machinery, erected, in 1767, a steam-engine, upon the original construction of Savery, which, notwithstanding the inconvenience of a great loss of steam from condensation, by its immediate contact with the water raised, has still some advantages from the simplicity of the apparatus which it requires, and has even lately been found to succeed well upon a small scale. But Mr Boulton's objects required a still more powerful machine, and he had the discernment to perceive that they might be very completely attained by the adoption of the various improvements lately made in the steam-engine by Mr Watt of Glasgow, who had obtained a patent for them in 1769, the privileges of which were extended, in 1775, by an act of Parliament, to a term of 25 years. Mr Boulton induced this ingenious and scientific inventor to remove to Birmingham. They commenced a partnership in business, and established a manufactory of steam-engines, in which accurate execution kept pace so well with judicious design, that its productions continued to be equally in request with the public after the expiration of the term of that legal privilege, which at first gave the proprietors the exclusive right of supplying them; and which had been confirmed in 1792 by a decision of the Court of King's Bench against some encroachments on the right of the patentee. It was principally for the purpose of carrying on this manufactory with greater convenience, that the proprietors established an iron-foundry of their own at Smethwick, in the neighbourhood of Soho.

In 1785, Mr Boulton was made a Fellow of the Royal Society, about the same time with Dr Withering, and several others of his scientific neighbours. In 1788, he turned his attention to the subject of coining, and erected machinery for the purpose, so extensive and so complete, that the operation was performed with equal economy and precision; and the coins could not be imitated by any single artist for their nominal value; each of the stamps coining, with the attendance of a little boy only, about eighty pieces in a minute. The preparatory operation of laminating and cutting out the metal, is performed in an adjoining room; and all personal communication between the workmen employed is rendered unnecessary, by the mechanical conveyance of the work from one part of the machinery to another. A coinage of silver was executed at this mint for the Sierra Leone Company, and another of copper for the East Indies, besides the pence and halfpence at present in circulation throughout England, and a large quantity of money of all kinds for Russia. In acknowledgment of Mr Boulton's services, and in return for some specimens of his different manufactures, the Emperor Paul made him a present of a valuable collection of medals and of minerals.

Mr Boulton obtained, in 1797, a patent for a mode of raising water by impulse, the specification of

Boulton
Bourbon.

which is published in the ninth volume of the *Repository of Arts*, p. 145. It had been demonstrated by Daniel Bernoulli, in the beginning of the last century, that water flowing through a pipe, and arriving at a part in which the pipe is suddenly contracted, would have its velocity at first very greatly increased; but no practical application of the principle appears to have been attempted, until an apparatus was set up, in 1792, by Mr Whitehurst, for Mr Egerton of Oulton, in Cheshire; consisting of an air-vessel, communicating with a waterpipe by a valve, which was forced open by the pressure or rather impulse of the water, when its passage through the pipe was suddenly stopped by turning the cock, in the ordinary course of domestic economy; and although the pipe, through which the water was forced up, was of moderate height, the air-vessel, which was at first made of lead, was soon burst by the "momentous force," as Mr Whitehurst very properly terms it. The apparatus had excited much attention in France, under the name of Montgolfier's hydraulic ram, and Mr Boulton added to it a number of ingenious modifications; some of which, however, are more calculated to display the vivid imagination of a projector, than the sound judgment of a practical Engineer, which had in general so strongly characterized all his productions.

He died, after a long illness, in possession of considerable affluence, and of universal esteem, leaving a son and a daughter to profit by the wealth and respectability which he had acquired. He was buried on the 24th of August at Handsworth, near Soho, attended by a procession of 600 workmen, and by a numerous train of his friends and acquaintance. (*Monthly Magazine*, Oct. 1809, p. 368.) (I. J.)

BOURBON, ISLE OF. In the *Encyclopædia* will be found a pretty full account of the discovery and settlement of this Island. There has since appeared the work of M. Bory de St Vincent, which, though intitled *A Voyage to the four principal Isles of Africa*, is, in fact, almost entirely occupied by a very detailed account of Bourbon. In 1811, also, an officer attached to the British expedition against that Island, published an *Account of its Conquest*, with an Appendix on its Present State. From these materials we are enabled to make some important additions to the information formerly communicated.

Structure and Aspect. The physical structure of this Isle being the point on which most new light has been thrown, seems to merit our first attention. Bourbon does not, like the Isle of France, consist of a level plain, from which conical hills arise in detached masses. The whole Island is as it were one mountain, having its most elevated points in the centre, and thence sloping gradually down to the sea. This great mountain, however, is split into two portions, of which the loftiest, situate in the northern part, is called the *Gros Morne*, and its summit, the *Piton des Neiges* (Snowy Peak). There is here no present action of volcanic fire; but the frequent occurrence of deep valleys or basins, rapid rivers bordered by perpendicular walls of rock, hillocks precipitated into these valleys and torrents, basaltic prisms often disposed in regular colonnades, strata thrown into the most irre-

gular positions,—all these, in M. Bory de St Vincent's opinion, indicate terrible physical revolutions in former times. The northern mountain is entirely volcanic, and the phenomena present themselves in an extraordinary state of frequency and activity. This writer not only conceives both these mountains to be originally volcanic, but the whole Island to have been thrown up by the action of subterraneous fire. The two mountains appear to him also to have formerly composed only one, having an intermediate summit higher than that of either now is. The volcanic agitations, however, having hollowed the internal part of this great mass, the exterior crust fell in, and reduced the Island to the shattered state which it now exhibits. To a great extent, indeed, it is divided into two portions by an immense hollow, bordered with perpendicular walls of rock, which, after running parallel for seven or eight miles, form an arch and unite. At the foot of the volcano is found an immense tract of what the inhabitants call *Brulé* "burnt country;" supposed to have been formed by the lava spreading into a species of fiery lake, and then consolidating into the present surface. It is destitute of all vegetation whatever; its colour is of the gloomiest black, the surface broken by holes, crevices, and innumerable asperities of every description. These, joined to its hard and brittle consistence, render it impossible to be trod without the severest injury to the feet. Those of our traveller's attendant negroes were almost torn to pieces; and his own, though defended by strong shoes, were wounded in several places.

The streams of Bourbon are mere mountain torrents, which descend from steep to steep, and throw themselves into the sea. In their descent, they dig for themselves deep ravines, bordered by lofty, almost perpendicular walls. The largest river, however, that of St Denis, has not a longer course than seven or eight miles. These deep and foaming torrents, the rude surface of the ground, and the perpendicular rents by which it is everywhere broken, render travelling through Bourbon a most arduous undertaking. M. Bory de St Vincent was assured, that his plan of reaching the two principal peaks was altogether impracticable; but his enterprise, and love of science, enabled him to surmount all the intervening difficulties.

In the ascent to the summit of the volcanic mountain, the obstacles encountered were truly formidable. Sometimes the sides of nearly perpendicular rocks were to be climbed; at other times, a road was to be made by cutting down the bushes and filling up the crevices; while a mist, which rises every day from the sea, rendered it impossible to distinguish his companions at the smallest distance. At length they reached the summit of the *Mamelon central*. The crater here, to which the name of Dolomieu was given, consists of a cavity forty fathoms in diameter, and about eighty feet deep, the bottom filled with confused piles of greyish coloured lava. The sides showed none of that soft lava which forms a species of varnish over the interior of other craters; they consisted of irregular fragments of hard and com-

Bourbon. pact substances. Our author here notices the error of those who expect, when they reach the summit of a crater, to look down into an unfathomable abyss. The fact is, from whatever depth the liquified substances may have ascended, that, when the conflagration ceases, they harden and fill up the opening, so that only a very small void remains. Being led, however, by a sulphureous smell, to the left side of the present crater, they discovered a deep hollow like a tunnel, the walls of which were composed of burning lava; while, beneath, two columns of fiery matter, rising to the height of 120 feet, threw up a bloody light, which shone brightly, even amid the blaze of a tropical noon. This spectacle, accompanied with a sound similar to that of an enormous cascade, filled their minds with terror and admiration.

Our traveller, in ascending, had supposed the *Mamelon central* the highest peak of the volcanic mountain; but he now discovered, at the distance of about 200 fathoms, a still more elevated point, which, after himself, he named *Bory*. It is a vast elliptic basin, the largest diameter of which is 120, and the smallest 100 fathoms. The sides rise perpendicularly like walls, and are 200 feet high at their greatest elevation. There were some broken parts, however, by which the travellers could descend into the abyss. They found it tolerably level; but the volcanic ashes with which it was bestrewed, hid the scorise and other substances which filled it. In the centre was a crevice the depth of which they could not discover. This crater was entirely silent.

The travellers spent the night on the crater *Dolomieu*; but the tremendous sounds, the blaze of light, and the singularity of their situation, scarcely allowed them to close their eyes. At about 1200 feet beneath, they perceived a stream of lava issuing from the mountain, the outlet, probably, of those liquified substances which they saw fermenting at the bottom of the crater.

The crater is said to have been formed during a violent eruption of the volcano in 1791. In the beginning of June, a burning vapour appeared rising from the summit; then the side of the mountain opened, and a vast torrent of lava rushed into the sea. On the 17th of July, a subterranean noise, like the discharge of cannon, was heard throughout the Island; after which, there rose from the top of the mountain an enormous column of smoke, of a deep black, with white spots interspersed. The inhabitants, who had never before witnessed such a phenomenon, were struck with consternation. Soon, however, the column fell down, and formed a species of arch over the volcano. The falling in of the interior, undermined by the previous discharge, is supposed to have been the cause of the tremendous sound, and of the ultimate opening of the crater.

This is, perhaps, the most active volcano in nature. Since the Christian era, Etna has counted only twenty-seven eruptions; and Vesuvius twenty-four. But a resident at Bourbon assured our author, that, from 1785 to 1802, the mountain had vomited flames at least twice every year, and eight of the streams had entered the sea. The lava, however, scarcely ever issues from the summit of a crater,

but generally from openings far down the mountain, and sometimes almost on a level with the sea. It is remarkable, also, that earthquakes, which so generally desolate volcanic countries, are here unknown, or, at least, so slight, as to occasion no serious inconvenience. The constant escape of the subterraneous fire through the channel of the volcano, may, probably, be the chief cause which prevents it from shaking the surrounding regions. Another usual accompaniment, that of warm springs, is also wanting; and none of the waters are impregnated with any species of gas. No petroleum has been found, nor any metal, except iron.

Our traveller made next an excursion to the *Piton des Neiges*, which forms the summit of the *Gros Morne*, the highest mountain in the Island. This undertaking proved still more arduous. The season was favourable; yet, when they were about half-way up, a prodigious rain came on; and the road lay through wet and swampy grounds, which were soon entirely covered with water. The mists became so thick, that nothing could be distinguished. The negroes, accustomed to a milder air, were benumbed; and, refusing to proceed, would have perished with cold, had not the Frenchmen driven them forcibly on, till they came to a spot where they found shelter and refreshment. They spent here two nights; and, on the third day, were able to reach their destination. The view from the summit appeared to our traveller to equal the most majestic scenes of the Alps and the Pyrenees. In the Island beneath, every object was visible as on a map; while, on every side, the immeasurable extent of ocean mingling with the skies, made them feel as if insulated on this spot from the rest of the universe. The thermometer was so low as 8°. Here considerable masses of rock were observed, undermined to such a degree, that a very slight effort was sufficient to throw them down the precipices, where, displacing others, they rolled to a great depth, and caused prodigious havock. Every part of the mountain, indeed, appears furrowed and shattered by the violent action of the rains, which have already sensibly diminished its magnitude, and are likely more and more to produce that effect.

M. Bory does not appear to have instituted any investigation into the height of these mountains. Professor Jameson, in his *Geognosy*, estimates that of the *Gros Morne* at 9600, and that of the volcano at 7680 feet above the level of the sea. The French traveller gives a copious, but not very precise, account of its geological features. The lower part of the *Gros Morne* is composed of basalt, a substance which abounds in every part of the Island, and which, from the manner in which it is connected with and surrounded by lava, is conceived by our author to have been universally crystallized from a state of fusion. He notices, also, the frequent occurrence of what he calls *Trappean lava*; though this, as well as much of the basalt, would probably, by the disciple of Werner, be referred to some of the newer formations of Trap. On some of the precipices at the summit of the *Gros Morne*, there appeared an immense depth of horizontal strata, which

Bourbon. might have rendered an igneous origin improbable, had it not been so clearly proved by other phenomena. Large blocks of granite are found in the rivers which flow at the foot of the *Gros Morne*.

Political and Commercial State.

It is now time to take a view of the political and commercial aspect of Bourbon. By the Revolutionists it was called Reunion; but this name, which was never fully established among us, may be now supposed to have again given place to its ancient appellation. The Island is divided into eleven parishes, St Denis, containing the capital of that name, St Marie, St Susanne, St André, St Benoit, St Rose, St Joseph, St Pierre de la Riviere d'Abord, St Louis du Gaul, St Leu, and St Paul. St Denis can scarcely be called a city; the streets resemble roads in the country, being covered with grass and sand, under which are often concealed sharp pointed stones, which inflict severe wounds on the feet. The houses are built of wood, and are agreeable; they are constructed entirely with a view to coolness. The furniture is slender, and many of the rooms not even carpeted; a deficiency not arising from absolute poverty, but from the difficulty, in this remote situation, of procuring the artificial conveniences of life. The houses in the country are of a peculiar construction, very long, very narrow, and tapering to a point.

The Island is distinguished into the windward and leeward sides; of which the former, descending by a gentle slope, and refreshed by continual breezes, is fertile and smiling; while the latter is comparatively rude, dry, and barren. The torrents, continually washing away the soil, are supposed to augment the sterility. Only a narrow slope, about a league and a half inward from the sea, is under regular cultivation. The interior consists of immense forests, inhabited by a species of fugitive Mulattoes, who live almost in a state of nature. The reports as to the amount of the population are very various. M. Bory understood it, in 1768, to contain 4000 whites, and 15,000 slaves, and supposes that they have not much increased since that time; but the narrator of the expedition in 1811 gives the numbers then at 16,400 Europeans, 3496 free negroes, and 60,450 slaves. The precision of the numbers seems to indicate an actual enumeration.

The staple production of this Island is coffee. The first plants were early brought from Arabia, and soon flourished to such a degree, that the coffee of Bourbon was only second to that produced in the parent district. During the Revolution, the want of a regular market, by diminishing the encouragement to careful cultivation, sensibly lowered the quality. It is still, however, produced in large quantity. Next to it ranks the article of cloves. The clove-tree is of very easy cultivation; the chief disadvantage is the precariousness of the produce. It has been known in one year to yield only 1000 lbs., and in the next 500,000 lbs. Cotton, likewise, has been long a staple of the Island; but a violent hurricane in 1801, and a disease which afterwards made its appearance among the plants, discouraged a number of the planters, who accordingly began to employ their lands in the culture of coffee.

The following is stated to be the total produce of Bourbon, the Island on an average of several years:

Bourbon, Bourgoing.

Coffee	73,200 Cwt.	Value 732,000 piastres.
Cloves	180,000 lbs.	540,000
Cotton	240,000	60,000
Grain	185,000	57,000
Maize	2,500,000	21,000
Pease	200,000	4,000
Potatoes	280,000	2,800

1,488,800 piastres.

The imports consist of a great variety of European goods, the regular amount of which is stated at 280,000 piastres, besides a large contraband. Bourbon labours under the serious disadvantage of not possessing a single harbour, nor any roadstead in which vessels can ride with safety. The trade, therefore, can be conducted only through the medium of Mauritius, and is entirely in the hands of the merchants of that Island. (B.)

BOURGOING (JOHN FRANCIS DE), was born of an ancient family at Nevers, on the 20th November 1748. He was educated at the Military School of Paris, and devoted himself particularly to the study of the languages. At the age of seventeen he was sent by the government to Strasburgh, where he studied Public Law under the celebrated Professor Kugler. Having spent three years there, he received a commission in the regiment of Auvergne. When scarcely twenty, he was appointed Secretary of Legation at the Diet of Ratisbon; and after having been employed, during four years, in the discharge of various diplomatic functions, he returned to his regiment; where he continued to occupy himself with the study of Public Law. In 1777, he went as first Secretary to M. de Montmorin, who was appointed Ambassador to the Court of Madrid. Eight years afterwards, Montmorin having been recalled, Bourgoing remained eighteen months at Madrid in the character of Chargé d'Affaires. It was during this long residence in Spain that he collected the materials for his *Tableau de l'Espagne moderne*. On his return to France, in 1787, he was sent as Minister Plenipotentiary to Hamburgh; and, in 1791, he went in a similar capacity to Madrid, where he remained until the month of March 1793. Having again returned to France, during the most troublesome period of the Revolution, he retired to his native town, where for some time he filled the first municipal office. The revolution of the 18th Brumaire (10th November 1799) drew him at length from the bosom of privacy. In 1801, the First Consul appointed him Minister Plenipotentiary at the Court of Denmark, and afterwards at that of Sweden. In 1808, he was sent as Minister Plenipotentiary to Saxony. At Dresden he was attacked by the complaint which terminated his life; and he died at Carlsbad, whither he had repaired for the benefit of the waters, on the 20th of July 1811, at the age of sixty-three.

Bourgoing was a man of the most disinterested integrity; and he died poor, although he had been employed in various situations in which he might have

Bourgoing found opportunities of acquiring wealth. He left a family of five children, three sons and two daughters. The following is a list of his publications: 1. *Nouveau Voyage in Espagne, ou Tableau de l'état actuel de cette Monarchie*; first published in 1789, 3 vols. 8vo. The fourth edition augmented, was published under the title of *Tableau de l'Espagne moderne*, in 1807, in 3 vols. 8vo, with an atlas. This is the best known and most esteemed of his works, and has been translated into various languages. 2. *Mémoires, Historiques, et Philosophiques, sur Pié VI. et sur son Pontificat*, 2 vols. 8vo, 1798; second edition, 1800. Some prefer the first edition of this work, although the second is continued to the death of Pius VI. 3. *Histoire des Flibustiers, traduite de l'Allemand de M. d'Archenholtz*, Paris 1804, 8vo. 4. *Histoire de l'Empereur Charlemagne, traduction libre de l'Allemand du Prof. Hegewisch*, 1805, 8vo. 5. *Correspondence d'un jeune Militaire, ou Mémoires du Marquis de Lusigny et d'Hortense de S. Just*, 1778, 2 vols. 12mo. Bourgoing translated some other works from the German, and published several tracts of little importance. In 1808, he published an edition of the *Travels of the Duc du Chatelet in Portugal*; and he was the Editor of the *Correspondence of Voltaire with Bernis*. (H.)

BRAMAH (JOSEPH), a practical Engineer and Machinist, was born at Stainborough in Yorkshire, on the 13th of April 1749. His father rented a farm on the estate of Lord Strafford, and, being the eldest of five children, he was intended for the same employment. He exhibited, at a very early age, an unusual talent for the mechanical arts, and succeeded, when he was quite a boy, in making two violoncellos, which were found to be very tolerable instruments, and in cutting a single block of wood into a violin, chiefly by means of tools which were forged for him by a neighbouring smith, whom, at a subsequent period of his life, he induced to assist him in London as one of his principal workmen. Notwithstanding the ingenuity which he had thus displayed, his destination in life might have precluded its further cultivation, had he not, fortunately for himself and for the public, been incapacitated, when he was about sixteen, by an accidental lameness in his ankle, for the pursuit of agricultural labour. He was then apprenticed to a Carpenter and Joiner, who seems, however, to have contributed but little to his improvement in mechanical knowledge.

When the term of his engagement was expired, he obtained employment for some time in the workshops of a Cabinetmaker in London, and soon after established himself as a principal in that business. Another accidental confinement left his mind at liberty for a time to occupy itself with reflection and invention; and he employed his involuntary leisure in the improvement of some of the most humble, but not the least useful, of domestic conveniences. He obtained a patent for his inventions, and established a manufacture of these and other similar articles in Denmark Street, Soho; where he continued to simplify and improve the arrangement of the pumps and pipes subservient to his principal purpose. He procured, in 1783, a patent for a water-cock, intended to allow the fluid a more uninterrupted passage through it, than was practicable in the ordinary construction. He afterwards removed to

Piccadilly, and established the various branches of **Bramah's** manufactory in some extensive premises at Pimlico.

In 1784, Mr Bramah took out a patent for his improvement in locks, which certainly appear to be of very material importance: their peculiar character depends on the arrangement of a number of levers or sliders in such a manner, as to preserve, when at rest, a uniform situation, and to be only pressed down by the key to certain unequal depths, which nothing but the key can ascertain; the levers not having any stop to retain them in their required situation, except that which forms a part of the key. The construction is more particularly detailed in the specification of the patent (*Repertory of Arts*, V. 217.), as well as in the inventor's *Dissertation on Locks*, 8vo; and some additional modifications, allowing the key to be varied at pleasure, are described in a patent, dated in 1798. It is not easy to say why the application for an act of Parliament to prolong the privilege was unsuccessful, unless it was supposed that the inventor had been already sufficiently repaid for the share of ingenuity which his contrivance exhibited; but the report, that one of these locks had been readily opened, before a committee of the House of Commons, by means of a common quill, was a gross misrepresentation of the fact; the quill having in reality been previously cut into the required shape from the true key; and the experiment only served to show the perfection of the workmanship, so little force being required to overcome the resistance, when properly applied.

For different modifications of pumps and fire-engines, Mr Bramah took out three successive patents, the two last dated in 1790 and 1798. (*Repertory*, II. III.) His "rotative principle" consists in making the part, which acts immediately on the water, in the form of a slider, sweeping round a cylindrical cavity, and kept in its place by means of an eccentric groove; a construction which was very possibly suggested by his own inventive mind, but which had been before described, in a form nearly similar, by Ramelli, Cavalleri, Amontons, Prince Rupert, and Dr Hooke. The third patent related chiefly to the attachment of a considerable reservoir of water to the fire-engine, in a cylindrical form, and to the furnishing it with wheels of its own, of a proper size and strength to allow it to be conveniently worked.

There was somewhat more of originality in the idea of applying practically, to the purpose of a press, the well-known principle of the hydrostatic paradox; by which, as by a lever with arms capable of infinite variation, the smallest imaginable weight is made capable of holding in equilibrium a force incomparably greater. Mr Bramah's patent for the invention is dated in 1796. (*Repertory*, VI. 289.), and it has been one of the most successful of his numerous speculations. He added to it in a subsequent patent the contrivance of a "retainer," for keeping goods in a constant state of pressure, for an unlimited time after their removal from the press. The apparatus has certainly a considerable advantage in the great steadiness with which the force can be applied, in the facility with which it can be regulated, and the convenience with which it can be continued without

Bramah

Bramah.

alteration; and it has been extensively applied both on a small and on a large scale; for copying writings, for pressing gunpowder, for proving cables and chains, for raising weights of various kinds, and for drawing piles, and pulling up trees by the roots.

A simple but a very convenient arrangement of little pumps and pipes has been very generally employed in public-houses under the name of the *Beer-machine*: For this Mr Bramah took out a patent in 1797, describing it as part of an apparatus for retaining, drawing, and clarifying liquors (*Repertory*, IX. 361). He prefaces his specification with some general observations on the right of an inventor to a property both in the objects which he selects for his improvements, and in the means which he employs for the attainment of them; and demands of the public justice an ample security for both these rights; grounding this claim on his resolution to make a clear and unreserved disclosure of all his inventions. Besides the method of pumping up the liquors from the various casks through flexible pipes, without the necessity of entering the cellar, he describes a mode of converting every cask into a forcing pump, excluding the air, and raising the liquor to any part of the house, by a load on its head, which is to be converted into a piston. He mentions also a filtering machine,—a vent peg,—a method of making pipes,—and a new form of stop-cocks.

In 1801 he obtained a patent for some improvements in the construction of steam-engines, particularly relating to the boilers; and in 1802, for a very elaborate and accurate machine for producing smooth and parallel surfaces on wood and other materials. The tools of different kinds employed in this machine, such as gouges, spokeshaves, and planes, are carried with a considerable velocity by a rotatory motion, and come successively in contact with the wood, which is placed on a moveable carriage gradually advancing: the centre or gudgeon of the axis or shaft, instead of a common step, is supported by a barrel of oil, to which it is fitted by a collar; and this arrangement not only diminishes the friction very considerably, but allows the height of the shaft also to be very easily and accurately regulated, by means of a small forcing pump. The inventor thinks this liquid support likely to be as permanent as it is advantageous; but it may be apprehended, that the constant friction of such a collar would cause it to require frequent repairs, in order to prevent the escape of the oil so powerfully compressed. The machine has been erected on a large scale in the Arsenal at Woolwich, and is employed with perfect success. The specification includes the description of a mode of turning spherical surfaces, either convex or concave, by the simple contrivance of a tool moveable on an axis precisely perpendicular to that of the lathe; and of cutting out concentric shells, by fixing, in the same manner, a curved tool, nearly of the same form as that which is employed by the common turners for making wooden bowls.

An improvement in the processes for making paper, with the assistance of new machinery, in large sheets, was secured to the inventor, by a patent, in

1805 (*Repertory*, 2 Ser. VIII. 1). The description is accompanied by that of a mode of drying the paper on sliding frames, hung on lines like sashes, and of keeping it in a state of compression by retainers adapted to the hydrostatic press; but Mr Bramah had not leisure to introduce these arrangements into actual practice, although he had been at a considerable expence in preparing the apparatus.

His next invention was, however, very effectually carried into execution in a particular department, notwithstanding its unpromising appearance, as generally stated in the specification of the patent, which he obtained in 1806 (*Repertory*, 2 Ser. X. 329). He proposes to facilitate the process of printing, by means of a roller, composed of a number of circular plates, closely fitted together, and turning on the same axis, each bearing twenty-six letters, with figures, spaces, and various marks, either engraved or projecting, and capable of being shifted at pleasure, so as to express any single line by a proper combination of the plates. This is described as a substitute for common printing, copperplate engraving, and calico printing; and the ink is intended to be supplied by a trough fixed above and in contact with the cylinder. Now, it is obvious, that such a machine would be insufferably tedious and inconvenient for every purpose of common printing, which it would be scarcely possible to perform by its means; but when we discover that the inventor had probably in view the apparatus which he constructed the next year for the Bank of England, for numbering and dating their notes, we shall be aware that the means were admirably adapted to the end; a single line only being here wanted at once, in which a single figure was to be changed at each step, and that in a regular order. In fact, during the immense temporary circulation of one and two pound-notes, the Bank has been able, by this machinery, under the management of about 20 clerks, to perform the labour of 120, who were before required for the purpose.

Mr Bramah procured a patent, in 1809, for a mode of making and holding pens for writing, calculated to save the substance of the quill, by cutting a number of pens out of it, instead of a single one; and those, who are not in the habit of making their own pens, may often find a convenience in the portable form, in which this and other similar "pterophori" are arranged. In 1812, he brought forward his patent for the construction of main pipes, to be carried through the principal streets of a metropolis, of sufficient thickness to withstand a great force, to which the water within them is intended to be subjected, by proper pumps, furnished with air vessels; so that the water may not only be ready for the immediate extinction of fires, without the necessity of bringing an engine to the spot, but may also furnish a convenient moving power for various mechanical purposes, such as raising weights, by means of tubes sliding out of each other, like those of a telescope. He observes that he has frequently had occasion to employ a hydrostatic pressure, in many of his operations, equivalent to that of a column of water 20,000 feet high, which is about 4 tons for every

Bramah. square inch. He also asserts that he can form 500 tubes, each 5 feet long, capable of sliding within each other, and of being extended in a few seconds, by the pressure of air forced into them, to a length of 2500 feet; and, with a power of this kind, he seems to have imagined that he could raise wrecks, and regulate the descent of weights of various descriptions.

His improvements in wheel-carriages, for which he obtained a patent in 1814, consisted in fixing each wheel to a separate moveable axis, having its bearings at two distinct points of its length, but loosely inclosed between these points, in a cylinder filled with oil; and, in some cases, he proposes to fix the opposite wheels to the same axis, though with a power of turning very stiffly round it, in order to lessen the lateral motion of the shafts in very rough roads. He also suggests the use of pneumatic springs, formed by pistons, sliding in cylinders, as a substitute for common springs of metal.

The purpose of Mr Bramah's last patent was the prevention of the dry rot, by laying on the timber, meant to be preserved from it, a thin coat of Parker's Roman cement, much diluted with water; but he does not appear to have pursued this experiment, having transferred his right in the invention to other hands.

In addition to the seventeen patents which have been mentioned, he took out two or three others of less importance, at different times, besides a variety of contrivances, which he did not think necessary to appropriate to himself by a legal privilege. Mr Nicholson has mentioned a double plunger for a forcing pump, as described to him by Mr Bramah (*Nich. Jour.* VII. 50); which, in the form he has delineated, is certainly possessed of no particular advantage, producing only with a large apparatus the effect of a much smaller. Mr Bramah had erected, in the latter years of his life, some large machines at the Thames Bank, for sawing stones and timber; he had begun to devise some improvements in bridges and in locks for canals; and he had at one time been actually employed in the execution of some water-works belonging to the department of the civil engineer, which he had completed with ability and with success. His great and various exertions appear in some measure to have exhausted the strength of his constitution; and his last illness was immediately occasioned by a severe cold, taken in the prosecution of his experiments on the tearing up of trees, made in Holt Forest. He died in his sixty-sixth year, on the 9th of December 1814.

Mr Bramah was a sincere believer in the doctrines of the Christian religion; and, notwithstanding his diversified avocations, he left several manuscript essays on religious subjects. In his moral character, he was cheerful, benevolent, and affectionate; in his habits he was neat and methodical; and he knew well how to temper liberality with economy. He often kept his workmen employed more for their sake than his own, when the stagnation of trade deprived him of the means of disposing of the products of their labour. It is surely on the characters of such individuals that the wealth and prosperity of the British empire most essentially depend; an in-

ventive imagination, controlled by a sound judgment, an incessant activity of mind and body, a head that can direct, and a heart that can feel, are the genuine sources of that practical superiority which is well known to distinguish the productions of our national industry. (*Life of Mr Bramah, by Dr Brown, in the New Monthly Magazine for April 1815.*) (s. r.)

BRASIL. In the *Encyclopædia* will be found an account of the discovery of Brasil, with such particulars relative to its subsequent history, and circumstances, as could be collected from the most approved publications on the subject. We shall here add such further information as has been communicated to the public in the works of more recent travellers.

The name of Brasil, which was at first understood to apply to a small portion of the American coast from the mouth of the Amazons southward, now comprehends the whole Portuguese territories in South America. On the east, this region is bounded by the Atlantic Ocean, and on the west by Peru. To the north and south, its natural boundaries seem to be the two great rivers, the Amazons and the Plata; but its actual frontiers have been fixed by treaties, and have either receded from those natural boundaries, or been enlarged beyond them, according to the political interests and views of the different powers interested in the possession of those territories. This vast country, from the mouth of the river Amazons, almost under the equator, to the 35th degree of south latitude, extends in length about 2000 miles, and its greatest breadth, from east to west, is nearly the same; but, towards the south, it is contracted, by the mutual approach of its eastern and western boundaries, within much narrower limits. The mouths of its navigable rivers, and the windings of the shore, give it about 1200 leagues of sea-coast.

Viewed from the sea, Brasil appears on its first aspect mountainous, rough, and unequal; but, on a nearer approach, no prospect can be more picturesque and agreeable than that which it presents,—its eminences covered with magnificent woods, and its valleys with eternal green. The interior of the country, generally speaking, is one vast forest. But in the centre is the vast plain of Campos Parexis, which extends east and west for several hundred miles, and is covered with a light earth, and with heaps of sand, resembling from a distance, by its continual shifting and undulation, the agitated waves of the ocean. The soil is so loose and sandy, that the convoys of mules which have to pass this way, frequently sink into it, and make their way forward with great difficulty. The vegetation with which it is covered consists of a stunted species of herbage, with small leaves, round and pointed like a lancet. This immense sandy plain rises up towards the centre into chains of mountains, which are generally considered the highest in Brasil, and are extended over a space of more than 200 leagues. It is from this mountainous country that all those rivers proceed, which finally pour their tributary waters into the Amazons, the Paraguary, and the southern Atlantic. Those rivers, and the river Madera, which flows northward into the Amazons, together with their

Brasil. tributary streams, run along the interior frontier of Brasil for a space of nearly 1500 miles, and form the boundary by which this country is separated from the Spanish provinces.

Mountains.

The principal mass of mountains is to the northward of Rio Janeiro, towards the sources of those three great rivers in the interior, the St Francis, the Parana, and the Toccontins. These mountains not only abound in mines of copper and of iron, but they conceal besides rich mines of gold, diamonds, and other precious stones. From this elevated group, different chains are prolonged towards the south, in a direction parallel with the coast, under the name of *Cerro des Emeraldas*, and *Cerro do Frio*. Another branch, proceeding from the same centre, follows a similar direction to the south, while a third chain, under the name of *Matto-Grosso*, bends to the north-west towards the central plain, and forms the dividing ridge between the waters which flow southward into the Paraguay and the Parana on one side, and those which flow northward into the Toccontins and the Chingu, and finally into the Amazons, on the other. Between the Parana and the Paraguay, an extensive chain of mountains, running in a direction from north to south, intervenes, which, at its termination, diverges into other ranges, running from east to west. Divers other groups of mountains skirt, for a great distance, the banks of the river Toccontins, while another range, which is one of the most considerable in Brasil, extends towards the northern coasts, and forms a natural division between the provinces of Maranham and Pernambuco.

Rivers.

Brasil is watered with a profusion of great rivers. The longest is the Amazons, which, rising in Peru, enters the Brazilian territory by the south-west, is increased by the accession of the Rio Negro, which, from its great inundations, has been compared to a sea of fresh water; by the Rio Madera, or the River of Forests, which rises in the central mountains of Brasil, and has a course of more than 2000 miles, before it joins the Amazons; by the Topayos, which rises in the heights of the Campos Parexis, and has a course of 900 miles; and, finally, by the Chingu, which descends from the ridges of Matto-Grosso. This last river rises at the distance of 1200 miles from its mouth, and its course is interrupted by several cataracts. Its banks are covered with impenetrable forests, inhabited by tribes of warlike and independent savages. Farther to the east, the great river Toccontins falls into the sea near the mouth of the Amazons, and, being connected by a branch with the main stream, those two immense rivers mixing their waters, rush with one common current into the ocean. The land and sea seem to dispute the dominion of the extensive regions where this junction takes place, which are accordingly either parched by a burning sun, or deluged with periodical rains. About 300 miles before it falls into the ocean, the Toccontins is joined by the Aragua, which is nearly equal to itself in size, and from this point the united streams of these two rivers are navigable to the ocean. Their banks are skirted by mountains and forests, and towards their

Brasil. source they make their way across deep valleys and precipices, where the navigation is interrupted by numerous cataracts.

To the southward of the tributary streams of the Amazons, Brasil is chiefly drained of its waters by means of the great river La Plata. This river, for a considerable part of its course, skirts its interior frontier, running from north to south. For the space of nearly 1600 miles, it receives all the streams which flow down the eastern declivity of the Andes, while, for the same space, it receives all the waters of the Brazilian Andes, which take a westerly course into the interior. The land which divides the waters of the Amazons from those of the Plata, rises to its height between the 13th and 14th parallels of south latitude. Here it is that the Paraguay or the Plata has its rise, and its sources approach within a few miles of those of the Topayos, Chingu, and Toccontins, which are tributary to the Amazons. In many parts, indeed, owing to the configuration of the ground, the tributary rivers of the Amazons and the Plata appear as if they were blended together, and as if their respective streams were in a manner interlocked. From the sources of these rivers, the dividing ridge runs south-west, and afterwards, turning towards the north-east, makes a sort of circle round the head waters of the Araguay, a branch of the Toccontins, which are to be found, in consequence of this bend in the ridge, as far south as the 18th degree. In its course towards the north-east, the ridge confines the waters of the Toccontins within the 16th parallel of south latitude, and, running in a northerly direction parallel to the course of this last-mentioned river, it divides its waters from those of the Rio Francisco, which has its rise about the 20th degree of south latitude, and, after running to the north for a considerable space in the bottom of a longitudinal valley, turns round at length towards the east, and falls into the Atlantic about the 11th degree of south latitude. The Rio Francisco is the only considerable river of Brasil, which is unconnected either with the Amazons or the Plata. Along the Francisco, parallel to its course, runs a ridge of mountains distant from the Atlantic Ocean about 250 miles. This ridge divides the waters of the Francisco from those flowing directly to the ocean, which consist of a variety of insulated streams, such as the Rio Grande, the Rio Doce, and several others of inferior note.

To the south of the dividing ridge between the waters of the Plata and those of the Toccontins, the great river Parana, which flows into the Plata, on the eastern bank, about 700 miles from its mouth, is formed by the accumulated waters of several extensive valleys. From the east, it receives all the waters of the western declivity of that mountainous ridge which runs along the shores of the Atlantic, and rising to its height at the distance, generally, of some hundred miles from the coast, pours all its great streams into the interior, to make their way into the ocean by the channel of the Plata. The head waters of the Parana approach within less than 100 miles of the eastern shore, from which their course is westerly into the interior, until they turn towards the

Brasil.

south. To the southward of the Parana rises the river Uruguay. Its head waters, like those of the Parana, flow from the mountainous ridge which runs along the Atlantic shore, and they pursue a course somewhat similar, flowing down the western declivity into the interior, and afterwards turning in a circular direction to the south. The Uruguay falls into the Plata near its mouth, after a course of 1000 miles.

Soil and Climate.

In consequence of the immense extent of Brasil, from north to south, it possesses great variety both of soil and climate. The country in the vicinity of the Amazons is exposed to the tropical heats, which, however, are in some measure tempered by the natural humidity of the climate. In those regions, there is little distinction of seasons. The ground is continually covered with flowers and with trees, always green, while the abundant dews, the shade of the forests, and the delicious coolness of the nights, present the image of perpetual spring. In ascending towards the sources of the great rivers, the temperature is modified by the height of the ground; and within the elevated plains which spread out into the interior, fertile valleys are found, which possess a salubrious and temperate climate, and in which all the fruits of Europe grow to maturity, along with the native productions of America. Of this nature is the climate of Brasil towards Minas Geraes, Villa Rica and Saint Paul. In some of the more elevated mountainous situations, which are raised to the height of 5000 and 6000 feet above the level of the sea, and towards the southern extremity of Brasil, the air is still colder, and the soil produces, in great perfection, both European fruit and grain.

The west wind, passing over vast marshy forests, is frequently found to be unhealthy in the interior parts, while the excessive heat which follows the course of the sun, fills the atmosphere with igneous particles, which produce occasionally fatal consequences. But those unhealthy blasts are corrected by the influence of the aromatic plants which abound in the woods, and which fill the air with their fragrance, so that it can be plainly perceived at several leagues from the shore, when the wind blows in that direction.

From the month of March to August, the rainy season prevails upon the coast. During the rest of the year, there is almost constant drought, the wind blowing from the north, with little interruption. Under the influence of these dry and parching blasts, vegetation languishes, and all the higher and more exposed parts appear to be burnt up and withered. The sea breeze, which ushers in the rainy season, refreshes the atmosphere and reanimates vegetation.

The interior of Brasil consists in many parts of one continued forest, in which the trees are covered with brushwood and twigs, twining round them even to their summits, after which they frequently make their way again to the earth, where they take root, and, mounting anew, they grow from one tree to another, until the whole forest is laced together by this vegetable cordage, and rendered completely im-

practicable. It sometimes grows to the thickness of a man's leg, and is so closely interwoven that neither animals nor birds can pass across it. When young, these twigs are flexible, and frequently serve for ordinary purposes instead of cords. Mr Mawe mentions that he had often seen negroes convert them into bridles, and ride with them for days together. In some species of this underwood, if an incision is made, a considerable quantity of cool and excellent water is procured. The shrubs which yield this precious resource are found in marshy countries, or in sandy plains, where, without this assistance, the traveller would die of thirst. The wild recesses of those impenetrable forests are inhabited by great numbers of apes, which multiply undisturbed in these inaccessible abodes.

At a little distance from the coast, the country is covered with numerous varieties of the palm-tree, among which we meet with that celebrated species, whose long, serrated, lancet-formed leaves are composed of innumerable fibres, which rival silk both in fineness and strength. These are frequently used for fishing-lines. Here also is to be found the Brazilian cocoa tree, which is thicker and more elevated than that of the Indies,—also the tree called the *pekia*, which bears a fruit large and hard, something similar both in shape and size to a common ball, so that it is dangerous to be near it when the fruit falls to the ground,—and the Brazilian myrtle, distinguished by the shining of its silver bark. No country in the world furnishes so many precious woods for dyeing, for cabinet work, or for ship-building. The cedar, the wild cinnamon tree, and the rose-wood trees, are improved by being worked, and resist for a long time the action both of the water and of the air. There is, besides, an immense variety of other species of trees, adapted for every purpose, either of utility or ornament; and it is in Brasil, also, that those gigantic trees are to be found which rise to the height of 80 feet, and which are so well adapted by their size for the construction of the largest ships.

The woods of Brasil are full of rapacious animals, such as the tiger-cat, the hyena, the saratu, which is the size of a fox, but much more ferocious and brave. The jaguar, from its strength and ferocity, the terror of the Brazilian peasantry, is frequently met with; also the porcupine, which, when it is irritated, darts its quills with such force as to occasion serious wounds. This animal must not be confounded with the armadillo, or with the common porcupine, which rolls itself up like the hedge-hog, and presents to its pursuers an impenetrable coat of mail. The farmers in Brasil are much infested by ounces, which are of various colours, some black and brown red, and are exceedingly ravenous and ferocious. This animal is hunted with dogs, and when it is run down, a contest ensues, which is seldom terminated without the loss of some of the dogs. Wild hogs are common, and all sorts of monkeys; some of which, when asleep, snore so loud as to astonish the traveller. The tapir is the largest quadruped found in the country; in its form it resembles a hog, but is nearly the size of a calf. The most formidable rep-

Brasil. tiles are the corral-snake, the sorrocuco, and the jarraraca, all of them venomous, and generally dreaded by the inhabitants. The corral-snake is between two and three feet in length, and about two inches in circumference, with a pointed tail and white belly; the head is covered with white cubical scales, edged with black, and the back is adorned with red, black, and white spots, in alternate order. In the marshy countries of the south is found the boa-serpent, which grows to the length of 30 feet, and in thickness equals the body of a man. As some sort of compensation for the production of these monstrous reptiles, the forests of Brasil abound in an infinite variety of the most beautiful birds, which are distinguished not more by the brilliancy of their plumage than by the melody of their notes.

General State of Industry. The great extent of Brasil, and the general aspect of the country, diversified as it is by hill and valley, gives it such a variety of soil and climate, that it is well adapted to produce all that is necessary either for luxury or use; and the fruits and productions of the tropical climates, as well as all sorts of European grain, are accordingly found to flourish in its congenial soil. In no country would agriculture yield larger returns to the industrious farmer, and in no country is it more generally neglected. A propensity to seek after gold and diamonds, with which the country abounds, is fatally prevalent among the people; and to such a length is this carried, that they have lost all relish for sober industry. They will not be turned away from this, as they fancy, short road to wealth; and their whole time being wasted in a fruitless search after these precious productions, they entail upon themselves and their families wretchedness and want. It is a general remark, that those who devote themselves wholly to mining, are badly clothed and worse fed, while those who have attended to agriculture are well provided with every necessary of life. But though there are not wanting many examples of the superior advantages of agriculture, it is extraordinary that, throughout all Brasil, the husbandmen have ever been considered an inferior class to the miners; and it is probable that this prejudice will continue until the country being in a great measure exhausted of its gold and diamonds, its inhabitants shall be compelled to seek, in the cultivation of the soil, a sure and permanent source of wealth. Most of the towns in the southern provinces of Brasil were first settled by bands of adventurers, who penetrated into the interior in quest of the precious metals; and when they had gradually exhausted the country of its mineral treasures, they were then compelled to employ themselves in husbandry. The town of St Paul's, in the province of Minas Geraes, which contains about 15,000 inhabitants, was settled in this manner. The town of Villa Rica owed its origin to the same cause. The country around both these places has been in a great measure drained of its gold by the rapacious industry of successive adventurers. The inhabitants of St Paul's, the vicinity of which has been long exhausted, have betaken themselves to industry. But in Villa Rica, where the precious metal has not entirely disappeared,

Brasil. they still retain their blind passion for mining; and totally neglect the fine country around them, of which the produce would amply compensate them for the loss of its former wealth. The descendants of the original settlers in the interior of Brasil, have generally sunk into a deplorable degeneracy of manners. They are unfitted for active life by their education, their habits, and, still more by their hereditary prejudices. Perpetually indulging in prospects of fancied wealth, they neglect the means by which alone their hopes can be realized. They are listless and indolent, passing whole days in perfect inactivity, and leaving every trade to be occupied by mulattoes or negroes.

Every where throughout Brasil there are large tracts of unoccupied land, which may be obtained by making proper application to government, and may be afterwards held as freehold property. Other excellent lands are possessed by many indolent persons, who are either unwilling or incapable of turning them to any advantage. These may be bought at very low prices, and they afford every possible encouragement to enterprising settlers. Many districts abound with iron ore and limestone; there is excellent clay for making bricks,—wood in abundance for every purpose, and water at command. As an example of the profits which may be gained by farming in Brasil, Mr Mawe mentions having met with an industrious Priest, who, having obtained possession of a farm, which he diligently cultivated, had in the course of four years rendered it worth L. 400,—although he possessed only L. 8—*per annum*, his salary as a clergyman, with which to hire negroes for the cultivation of his property.

Maize, beans, cassava root, which is generally eaten as bread by all ranks, are very generally cultivated. In many parts wheat and other European grain is reared; and where the farmer has planted a sufficient supply of food for the consumption of the farm, he grows coffee, and, if he has the means, he prepares for growing and manufacturing sugar. The farm-houses are generally miserable hovels of one story; the floor is neither paved nor boarded, and the walls and partitions are formed of wicker-work plastered with mud. The kitchen is a filthy room with an uneven muddy floor, interspersed with pools of water; the fire-places are formed by the rude contrivance of three round stones; and as there is no proper chimney, the place is always filled with smoke, which vents itself through the door and other apertures, leaving all within black and dirty. In more remote parts of the country, the same habits of indolence prevail. "The people," says Mr Mawe, to whose researches we are indebted for much valuable information respecting this interesting country, "seemed to act as if the tenure by which they held their lands was about to be abolished; all around them had the appearance of make-shift; their old-houses fast hastening to decay, bore no marks of repair about them; wherever a bit of garden ground was inclosed, it appeared overrun with weeds; where coffee-trees, planted in former years, still existed, the present occupiers were too indolent to

Brasil.

gather the fruit; no inclosures were made for pasturage; a few goats supplied the little milk that was consumed, and cow's milk was rarely to be procured."

Gold and Diamonds:

Brasil has long been celebrated for the gold and diamonds with which it abounds; but so watchfully was this precious produce formerly guarded by the jealousy of the Portuguese Government, that no foreigner was ever permitted to penetrate into the interior; and, in consequence, no satisfactory information could ever be procured respecting those valuable productions. Lately, however, and more especially since the emigration of the Portuguese Royal Family to the Brasils, this policy has been relaxed; and we are indebted to Mr Mawe, who was freely permitted to visit both the gold and the diamond mines of the interior, and to examine every part of the works connected with them, for many curious details respecting this branch of domestic industry, by which the inhabitants are drawn from every other pursuit.

In the beds of almost all the rivers which have their rise in the interior of Brasil, gold is found in abundance, and the nearer the source of the river, the soil always proves to be the richer in mineral wealth. It is known that the head waters of all those streams which have their source in the provinces of Minas Geraes or of Goias, and which, running south-west, fall into the Parana, a branch of the great river Plata, or turning to the north-east, are carried by the Rio Francisco to the Atlantic, are rich both in gold and diamonds. Almost all the towns in the interior of Brasil, were established by adventurers in pursuit of gold, and they will be found, accordingly, to be situated near the sources of the great rivers. The town of St Paul is situated on the western declivity of the chain of mountains which run along the coast near the source of the river Tiete, which, running west, falls into the Parana. Villa Rica is, in like manner, situated near the source of the Paraiba, which falls into the Atlantic, and on the sources of all the other rivers, towns have been established by adventurers drawn to these remote and unfrequented regions by their eager searches after gold. The village of Paracatu is established on the sources of the Rio Francisco, between 300 and 400 miles north-west from Rio Janeiro; its population is estimated at 1000 souls; and it will soon be more numerous, as the rumoured discovery of some rich mines lately found in its vicinity, has already tempted many families to remove to it. Farther to the west, we meet with the head waters of the rivers Tocantins, and with those of the river Aragua, as we advance into the province of Matto-Grosso. There is every reason to believe that those unexplored regions abound in untouched treasures both of gold and diamonds. The town of Villa Boa is situated on the eastern waters of the river Aragua, in the province of Goias, and is 80 leagues to the west of Paracatu, from whence there is a good road. Several other villages have also been established, at no great distance, for the purpose of collecting the gold which is found in the channels of those mountain streams.

In various other parts of the Capitania, gold washings are established, at some of which gold is found of a very fine quality. Diamonds have been collected in some parts, which are more brilliant in their appearance than those found in the diamond districts of Cerro do Frio, but are not generally of so pure a water. It is known that the river Das Mortes, which belongs to the Capitania of Matto-Grosso, and flows in a large stream into the Aragua from the west, is auriferous; and, according to the experience of those most skilled in the nature of the country, the smaller streams which descend from the higher grounds, must be still more productive of gold. Some mining works were at one time established in these remote districts, which were abandoned, not from any scarcity of gold, but because the few inhabitants who had settled in the country, being far removed from the road, and in the midst of a swamp inhabited by savages, could neither be conveniently supplied with arms for their defence, nor with implements for their trade. Farther to the west is found the river Cuiaba, and the other head waters of the river Paraguay, all of which produce gold. The mines of Cuiaba are established on the river of this name, and near the town of Cuiaba, which is large, and is estimated to contain 30,000 inhabitants. They were discovered in the year 1718, and were long celebrated for the quantity of gold which they produced, which has been calculated at 20 arrobas (500 lbs.) annually. The metal is also said to be of an extremely fine quality. The head waters of all the other great rivers, such as the Chingu, the Topayos, and the Madera, which rise in this Capitania, and flow into the Amazons, are found to produce gold. On the river Arinos, which is a western branch of the Topayos, some establishments for collecting gold were begun in 1747. But they were afterwards abandoned, chiefly in consequence of the dangers to which the adventurers were exposed from the tribes of warlike Indians by which this country is infested. The inveterate hostility of the native tribes to the Portuguese, tends greatly to obstruct the progress of new settlements; as a body of adventurers must be collected sufficiently numerous to protect themselves against their savage enemies, before any settlement can be begun; and, even in this case, being in a state of perpetual watchfulness and alarm, their attention is continually distracted from agriculture or mining, to the more necessary business of war. But where the country is known to abound in gold or diamonds, adventurers soon crowd from all quarters to gather the rich harvest; the barbarous inhabitants are driven back into the desert; towns and villages arise; roads are opened; and the country around quickly assumes the appearance of cultivation and improvement.

The gold which is collected in Brasil, is found either in deep valleys or in the channels of rivers. It is generally contained in a loose marl-like stratum of rounded quartose pebbles and adventitious matter, called *cascalthão*, which rests upon granite, and is covered by earthy matter of variable thickness. Sometimes the gold is found covered by the soil at

Brasil. The depth of 20 feet, while at other times, on many of the hills where water can be collected for washing, particles of gold appear in the soil at little greater depth than the roots of the grass.

At the gold washings of Villa Rica, the bed of *cascalhào* was on the margin of the river; and Mr Mawe found the workmen engaged in cutting away the bank to the depth of, at least, 10 feet, before they could reach the vein containing the gold which was incumbent on the rock. The substance they had to cut through was clay, so strong that, though falls of water were precipitated upon it, and negroes were constantly working it with hoes of various kinds, it was with difficulty removed. Nor was this the only impediment; for, by the continual washing down of mud from the higher grounds, the *cascalhào* was five feet lower than the bed of the river, so that when the pits were sunk to its depth, they were soon filled with water, which had to be drawn off by means of machinery.

Gold Washings. When the stratum which contains the gold is found at a distance from the rivers, it is dug up and carried to a convenient place, where it is washed, for the purpose of separating the earth and other materials from the gold. The method of washing it is simple, and the following account of it is given by Mr Mawe, who was freely permitted to visit the different gold-washings established in the country.

"Where water" (he observes) "of sufficiently high level can be commanded, the ground is cut in steps, each twenty or thirty feet wide, two or three broad, and about one deep. Near the bottom a trench is cut to the depth of two or three feet. On each step stand six or eight negroes, who, as the water flows gently from above, keep the earth continually in motion with shovels, until the whole is reduced to liquid mud, and washed below. The particles of gold contained in this earth descend to the trench, where, by reason of their specific gravity, they quickly precipitate. Workmen are continually employed at the trench to remove the stones and clear away the surface,—which operation is much assisted by the current of water which falls into it. After five days washing, the precipitation in the trench is carried to some convenient stream, to undergo a second clearance. For this purpose wooden bowls are provided, of a funnel shape, about two feet wide at the mouth, and five or six inches deep, called *gamellas*. Each workman, standing in the stream, takes into his bowl five or six pounds weight of the sediment, which generally consists of heavy matter, such as oxide of iron, pyrites, ferruginous quartz, &c. of a dark carbonaceous hue. They admit certain quantities of water into the bowls, which they move about so dexterously, that the precious metal, separating from the inferior and lighter substances, settles to the bottom and sides of the vessel. They then rinse their bowls in a larger vessel of clean water, leaving the gold in it, and begin again. The washing of each bowlful occupies from five to eight or nine minutes; the gold produced is extremely variable in quantity, and in the size of its particles; some of which are so minute that they

float, while others are found as large as peas, and not unfrequently much larger. This operation is superintended by overseers, as the result is of considerable importance."

There is another mode of separating the gold from the *cascalhào*, which is described in the following manner: "Two planks about ten or twelve inches broad and about twelve or fifteen feet in length, are laid in the ground, forming an inclined plane, sloping one inch in twelve; two other planks, of similar dimensions, are fixed in the same direction at the lower end, forming a second inclined plane, with a fall of six inches from the former. On their sides are boards placed edgewise, and staked down to the ground, so as to form long shallow troughs, the bottoms of which are covered with hides tanned with the hair on, having the hairy side outwards, or, in defect of these, with rough baize. Down these troughs is conveyed the water containing the oxide of iron and the lighter particles of gold; the latter substance precipitating in its course is entangled by the hair. Every half hour the hides are taken up, and carried to a tank near at hand, formed of four walls, say five feet long four broad and four deep, and containing about two feet depth of water. The hides are stretched over this tank and well beaten, then dipped, and beaten repeatedly, until all the gold is disentangled, after which they are carried back and replaced in the troughs. The tanks are locked up at night, and well secured. The sediment taken from them being light, is easily washed away by the hand, in the manner before described, leaving only the black oxide of iron, called *esmeril*, and the gold, which is so fine that mercury is used to separate it."

In all those various operations of digging up the *cascalhào*, of removing it to a convenient place, and, finally, of washing away the earth from the gold, a great deal of time and labour is wasted which might be saved by adopting some very simple contrivances. In removing the earth, for example, to the place where it is to be washed, not a cart or a wheelbarrow is used. The whole is transported in bowls, which are carried on the heads of poor negroes, who have frequently, with these heavy burdens, to climb up steep ascents, where various methods might be adopted with little trouble or contrivance, to abridge this unnecessary labour. The hydraulical apparatus, in use for draining off the water, is cumbersome and expensive. In many cases, ordinary pumps would answer the purpose better, as they can be made at little trouble and expence, are easily repaired, and can always be ready to work at an hour's notice. It is singular, that this very common and simple machine should be utterly unknown in those parts. The method practised in washing the *cascalhào* in bowls, is extremely tedious, and might be easily shortened. Great advantages would also be derived from the use of properly constructed mills for breaking down the hard substances which contain gold, and which might then be washed in the same manner as the softer matter. We are informed by Humboldt, that, in the silver mines of Mexico, this operation is executed with admirable skill,

Brasil.

and with great advantages.* The hardest substances, previous to their amalgamation, are reduced to a fine powder; by which process every particle of the precious metal which they contain is carefully extracted. Those who are employed in washing for gold in Brasil, are exposed to various disadvantages from the scarcity and high price of iron; and owing to this circumstance they are frequently in want of the most ordinary tools. This fact strikingly illustrates the indolence and want of enterprise which generally prevails in this country. A blind pursuit after gold seems to be the exclusive occupation of all classes, in favour of which the most valuable resources of the country are neglected. In many parts iron-ore is produced in abundance, and there is little doubt that, if any spirited individual were to devote his attention to this branch of industry, he would not only facilitate the acquisition of the precious metals, but he would more rapidly acquire wealth, than if he were directly seeking after it by establishing gold-washings.

The particles of gold being separated, by washing, from the stratum in which they are found, are brought to the nearest mint, where a fifth part is taken for the crown. The remainder undergoes a process of amalgamation with mercury, and is afterwards poured into an ingot, which being sent to the assay master, he ascertains its weight and fineness, and puts upon it the public stamp, when it is delivered to the owner for circulation. The operation of melting seldom occupies more than ten minutes; and those who deliver into the mint any quantity of gold dust, may reckon on having it returned to them for circulation in less than an hour. The gold is of different qualities. Some of the bars which are in circulation are so low as 16 carats, while others are as fine as 23½ carats, which is within one-half carat of what is denominated pure gold. The standard is 22 carats fine, and gold exceeding this standard receives a premium in proportion to its fineness. Gold of a low standard is generally of a pale colour, which is ascribed to the mixture which it contains of silver, platina, or some other metals.

Diamond Washings.

The washing for diamonds is another favourite employment in Brasil, and, being esteemed too lucrative a branch of business for individuals to enjoy, is now prosecuted by the state as a royal monopoly. The district of Cerro do Frio, or of the cold mountains, in which the diamond works are established, is situated on the highest ridge of those mountains; which, running nearly parallel with the coast of Brasil, rise to their height at the distance of about 300 miles in the interior, and divide the streams which fall into the Atlantic by the Rio Doce and the Rio Grande, from those which, running westward into the Rio Francisco, are carried to the north by that river, and fall into the Atlantic about the 11th degree of south latitude. It is at the sources of these streams that the diamond works are situated. This district consists of a range of rugged

Brasil.

mountains that run north and south, and are generally considered to be the highest in Brasil. The tract of country termed the diamond ground, extends about 16 leagues from north to south, and about 8 leagues from east and west. Nearly in the middle of it stands the town of Tejuco, 400 miles north of Rio Janeiro, in a straight line, but nearly double that distance by the winding roads of the mountains. It contains about 6000 inhabitants, and is chiefly supported by the diamond works in its neighbourhood. The most considerable of these is situated on the head waters of the river Jijitonhonha, a branch of the Rio Grande, while others are established on the Rio Velho, a branch of the Francisco, and on the other numerous small streams which have their rise in this mountainous region. The river Jijitonhonha, where the diamond works are established, is about as wide as the Thames at Windsor, and is in general from three to nine feet deep. The *cascalhao* consists of nearly the same materials as that which contains the gold, and it has to be dug from the bottom of the river, which, for this purpose, is diverted into a new channel. When Mr Mawe visited these works, they were working at a bend of the river, from which the water was diverted by means of a canal cut across the tongue of land round which it held its course; an embankment formed of several bags of sand, being carried quite across the old channel, just below the head of the canal. After this operation, the deeper parts of the river are laid dry by means of pumps, and the earth being removed, the *cascalhao* is dug up and removed to a convenient place for washing. This fatiguing work was until lately performed by the unassisted labour of the negroes, who carried the *cascalhao* in bowls on their heads, and in many establishments this mode of working still prevails. Two inclined planes have been since contrived, along which, by means of a water-wheel, two carts are set in motion, one of which descends empty by one inclined plane, while the other, loaded with *cascalhao*, is drawn to the top of the other. At some of the diamond works, on the same river, the *cascalhao* is conveyed to the place for washing by different and more improved machinery, and railways are even constructed on some parts of the uneven ground. The *cascalhao*, when it is carried from the bed of the river whence it is dug, is laid down in heaps, containing apparently from five to fifteen tons each; and they calculate in digging as much during the rainy season, as will give full employment to all their hands during the months which are not subject to rain. Into all the various parts of the works erected for washing the *cascalhao*, water is distributed by means of aqueducts, constructed with great ingenuity and skill. The following is an account of the mode of washing for diamonds, as it was observed by Mr Mawe, which appears to be highly curious and interesting.

"A shed is erected in the form of a parallelogram, 25 or 30 yards long, and about 15 wide, consisting of upright posts, which support a roof

* Political Essay on the Kingdom of New Spain, Vol. III. p. 256.

thatched with long grass. Down the middle of the area of this shed, a current of water is conveyed through a canal, covered with strong planks, on which the *casalhão* is laid two or three feet thick. On the other side of the area is a flooring of planks, from four to five yards long, imbedded in clay, extending the whole length of the shed, and having a slope from the canal, of three or four inches to a yard. This flooring is divided into about twenty compartments or troughs, each about three feet wide, by means of planks placed upon their edge. The upper ends of all these troughs (here called canoes) communicate with the canal, and are so formed that water is admitted into them between two planks that are about an inch separate. Through this opening, the current falls about six inches into the trough, and may be directed to any part of it, or stopped at pleasure by means of a small quantity of clay. For instance, sometimes water is required only from one corner of the aperture, then the remaining part is stopped; sometimes it is wanted from the centre, then the extremes are stopped; and sometimes only a gentle rill is wanted, then the clay is applied accordingly. Along the lower ends of the troughs, a small channel is dug to carry off the water.

“ On the heap of *casalhão*, at equal distances, are placed three high chairs for the officers or overseers. After they are seated, the negroes enter the troughs, each provided with a rake of a peculiar form and short handle, with which he rakes into the trough about 50 or 80 lbs. weight of *casalhão*. The water being then let in upon it, the *casalhão* is spread abroad, and continually raked up to the head of the trough, so as to be kept in constant motion. This operation is performed for the space of a quarter of an hour; the water then begins to run clearer, having washed the earthy particles away, the gravel-like matter is raked up to the end of the trough: after the current flows away quite clear, the largest stones are thrown out, and afterwards those of inferior size, then the whole is examined with great care for diamonds. When a negro finds one, he immediately stands upright and claps his hands, then extends them, holding the gem between his fore-finger and thumb; an overseer receives it from him, and deposits it in a gamella or bowl, suspended from the centre of the structure, half full of water. In this vessel all the diamonds found in the course of the day are placed, and at the close of work are taken out and delivered to the principal officer, who, after they have been weighed, registers the particulars in a book kept for that purpose.

“ When a negro is so fortunate as to find a diamond of the weight of an octavo ($17\frac{1}{2}$ carats), much ceremony takes place; he is crowned with a wreath of flowers, and carried in procession to the administrator, who gives him his freedom, by paying his owner for it. He also receives a present of new clothes, and is permitted to work on his own account. When a stone of eight or ten carats is found, the negro receives two new shirts, a complete new suit, with a hat and a handsome knife. For smaller stones of trivial amount, proportionate premiums are

given. During my stay at Tejuco, a stone of $16\frac{1}{2}$ carats was found; it was pleasing to see the anxious desire manifested by the officers that it might prove heavy enough to entitle the poor negro to his freedom, and when, on being delivered and weighed, it proved only a carat short of the requisite weight, all seemed to sympathize in his disappointment.”

The flat pieces of ground which lie on each side of the river, are generally equally rich throughout their whole extent, and the officers employed in the works are enabled to calculate the value of the places unworked from the parts adjoining. The substances which are considered the best indications of diamonds are bright, bean-like, iron-ore; a slaty flint-like substance, resembling Lydian stone, of fine texture; black oxide of iron in great quantities; rounded bits of blue quartz; yellow crystal, and various other materials, entirely different from any substance found in the adjacent mountains. Diamond washings have been established on the river Jijitonhonha, and the neighbouring streams for many years, and great quantities of the finest stones have been collected. These vary extremely in size, some being so small that four or five are required to weigh one grain, and consequently there are sixteen or twenty to the carat. It is calculated that only two or three stones of from 17 to 20 carats are found in the course of a-year, and not once in two years is there found throughout all the diamond washings a stone weighing 30 carats. Mr Mawe mentions, that during the five days in which he was employed visiting these works, the number of diamonds found amounted only to forty, the largest of which weighed only four carats, and was of a light green colour.

The diamond district was first explored by some enterprising miners from Villa do Principe, which is about 60 miles south-east from Tejuco. Their search was after gold, which they sought for on the banks of the rivulets in the neighbourhood of Tejuco, and not suspecting that they contained diamonds, they were not aware of the value of these stones when they were first discovered. Nor was it until they were sent to Europe that their worth was accurately ascertained. Immediately on this discovery, the Portuguese Government erected Cerro do Frio into a distinct district, which was placed under its own peculiar laws and regulations; and the lucrative trade of searching for diamonds being prohibited to all individuals under the severest penalties, was constituted a strict monopoly for the benefit of the crown. But in this, as in most other cases, the power of the Government was counteracted by the fraud and cunning of its subjects. By means of the intrigues and misrepresentations of interested individuals, government was prevailed on to farm these territories to a company, who were bound only to employ a certain number of negroes, or to pay a certain sum for each negro employed over the quantity, agreed for. Under cover of this lease, every species of fraud and corruption was practised. About double the stipulated number of negroes was employed, and the agents of Government were bribed to connive at this fraud. Seasonable presents were also made in order

Brasil.

Royal Monopoly of Diamonds

Brasil.

to secure influence at court; and, by such arts, the farmers of these valuable works were continued in their lease until about the year 1772, when Government resolved to appoint its own officers to superintend this valuable branch of its revenue. Under this new system of management, abuses, however, still continued; and the establishment was run in debt to foreigners, who advanced a considerable sum to carry it on, on condition of receiving, as security, all the diamonds which it produced. This debt still remains unpaid, and there are other incumbrances from which it is not likely that the establishment will ever be freed while it continues under the management of the state. According to the information of Mr Mawe, "the expences of these works amounted, during a period of five years, from 1801 to 1806 inclusive, to L.204,000; and the diamonds sent to the treasury, at Rio Janeiro, during the same period, weighed 115,675 carats. The value of the gold found in the same period, amounted to L.17,300 Sterling, from which it appears that the diamonds actually cost Government 33s. 9d. *per carat*. These years were esteemed singularly productive; the mines in general do not yield to Government more than 20,000 carats annually."

Consequences of the Royal Monopoly.

All the gold collected in Brasil being liable to pay a fifth share to the crown, the temptation to evade so heavy a tax has given rise to a contraband trade in this precious commodity, and various precautions have been adopted to prevent the injury thence arising to the revenue. But the temptation is even greater to carry on an illicit trade in diamonds than in gold, because, in the one case, it is only the royal fifth which the smuggler gains by evading the regulations of the state, while, in the case of diamonds, he gains the whole value of the article which he succeeds in conveying clandestinely away. The irresistible temptation which this monopoly holds out to illicit trade, is met by regulations of corresponding strictness and severity. For the security of the revenue, the country has been subjected to a most vexatious system of military police, and the unhappy offender, who is detected in the heinous crime of illicit trade, is doomed to experience, in a cruel and hopeless captivity, or in transportation to the African colonies, the utmost vengeance of his rapacious rulers. The more effectually to counteract the projects of the smugglers, the diamond district is placed under peculiar regulations. On all the various roads leading to it, registers or military posts are established, in which is stationed an officer with twenty horse soldiers under him. These are continually patrolling the roads. Whenever they observe a stray passenger they instantly ride up to him, questioning him as to his business and the purposes of his journey, and he must satisfy them as to all these particulars before he is allowed to pass. They are authorized to stop all travellers without distinction, and to search, with the utmost rigour, those whom they suspect of concealing gold dust or diamonds. All persons passing with mules are ordered to stop at these registers, and to deliver their passports to a soldier for the inspection of his commanding-officer, who, if he is satisfied that there are no grounds of suspicion, allows them to proceed. But if he judges

Brasil.

otherwise, the mules are unloaded, and all the baggage subjected to the strictest scrutiny. If, in the course of these examinations, a negro is suspected of having swallowed a diamond, he is confined to a bare room until the truth can be ascertained. These buildings are all provided with strong cells for the confinement of suspected persons. In the management of the works many precautions are adopted to prevent the negroes from embezzling diamonds. They work immediately under the eye of their overseers, who sit on a seat raised above them for the purpose of watching them, and, at the word of command from the overseers, they instantly move into each other's troughs, so that no collusion can possibly take place.

Notwithstanding the strictness of the police, however, and the severity of the criminal law, there is no doubt that a contraband trade, both in gold and diamonds, is carried on in Brasil to a great extent; and the present plan upon which the diamond works are managed, is calculated to give every facility to this forbidden traffic. Owing to the pecuniary embarrassments of the establishment, the Intendant has never been able to purchase a stock of negroes to carry on the work, and he is, in consequence, obliged to engage the negroes of others. The hiring out of negroes to the diamond works has long been the favourite occupation in Tejuco, in which rich and poor engage with equal eagerness to the full extent of their capital; and numbers of persons are supposed to reside in Tejuco with no other view than to place their negroes in this profitable employment. There is no apparent reason for this anxiety among all classes to hire out the industry of their negroes, seeing that the pay is small, the labour hard, the maintenance poor, and the treatment not always the most gentle. It is conjectured, therefore, with great probability, that the real object is to gain access to these works for the purpose of purloining some portion of their precious produce; and it is certain, that by whatever means they are procured, the market is supplied with large quantities both of contraband gold and diamonds. The great value and small bulk of these articles, hold out such temptations, and, at the same time, such facilities for secreting them, that no laws, however strict, can possibly counteract those strong inducements to illicit trade.

In this view, the policy of imposing so heavy a tax on gold may well be questioned; and, in regard to the monopoly of diamonds, there can be no doubt that it is both impolitic and tyrannical. There is something mean and rapacious in the principle of those measures, of which the object is to seize upon all the most valuable produce of the country; and Government, having set the example, can hardly expect that its subjects will be outdone in the practice of avarice and fraud. In this, as in all other cases, the sagacity and address of individuals will prove an overmatch for the violence of power. Harsh and cruel laws may be passed; but, while the inducement to violate them continues, adventurers will be found to run all risks; and though individuals may occasionally incur the penalties of the law, the contraband trade will flourish.

Brasil. rish in proportion to the bounty held out by the regulations of the state. The colonial policy of Europe seems generally to have been founded on the most false calculations. Even in respect to revenue, a moderate tax on several articles of general consumption would, in a flourishing community, be far more productive than this monopoly established in Brasil. The authors of these devices for cramping industry seem to imagine, that, for the diamonds which are exported by private adventurers, no valuable equivalent is received in return. They make no calculation of the additional capital which they bring into the country; of the increase thus made to the fund for maintaining productive industry; and of the general vigour diffused by a free trade over every department of an industrious community. They do not reflect, that an improving commerce, cherished and protected by an enlightened government, would soon pour into the treasury, as the cheerful gift of a free and a flourishing people, a far ampler revenue than can ever be extorted from them by all the miserable devices of tyranny.

**Oppressive
System of
Taxation.**

There are various other duties imposed on the transit of commodities into the interior, which are both oppressive and impolitic. They generally take place at the crossing of ferries, and are laid on according to the weight of the goods passing, without any regard to their bulk or value. All heavy articles, in consequence, pay high, while woollens, cottons, and other light goods, pay only about 8 or 10 *per cent.* Iron, which is in great request in the interior, pays an enormous duty, of nearly 100 *per cent.* This is the case also with salt, which, being absolutely necessary in this country for the subsistence of the cattle, the effect of the tax is to discourage breeding, and is, in this view, most injurious to the interests of agriculture. A duty of 2*d.* *per lb.* is also imposed on all commodities which pass into the mining districts, and a new tax has lately been laid on the rents of houses. We are informed, that the weight of the taxes presses most severely upon the poorer classes, and the same remark seems applicable to other parts of the country. A tenth in kind is raised upon cattle, poultry, and agriculture, and even upon salt. This belonged, in former times, to the clergy; but as, in the infancy of Brasil, it was inadequate to their support, they petitioned Government to have it commuted into a fixed stipend. This petition was acceded to. In the meantime, by the improvement of the country, the tithes begun greatly to increase in value to the profit of the Government, and to the loss of the church, and the clergy now complain grievously of this agreement, by which, for a temporary advantage, such a valuable revenue was surrendered. For the due collection of the public revenue, the country is parcelled out into extensive districts, and the taxes of each district are farmed out to the highest bidder. These again dispose of their farm in small shares to under farmers, who oppress and plunder the people for their own private emolument. Besides a tithe of all the cattle, which is levied on estates in the interior, meat in the shambles pays a duty of about 25 *per cent.* Fish pays a 10th, and afterwards a 15th. A duty of 10 *per cent.* is imposed on every transfer

VOL. II. PART II.

Brasil. of immoveable property, and of 5 *per cent.* upon the sale of all moveable. Rum, whether for exportation or home consumption, pays a duty of from 15 to 20 *per cent.* Cotton pays a 10th, and, on its exportation, pays an additional duty of 1½*d.* *per lb.*; and all goods imported are liable at the custom-house to an *ad valorem* duty of 15 *per cent.* There is also a tax imposed at Pernambuco for lighting the streets of Rio Janeiro, while its own streets are in total darkness. The produce of these duties is expended in the support of the civil Government, in which, owing to the excessive multiplication of offices with inadequate salaries, speculation and bribery prevail to such an extent, as not only to escape punishment, but even any great degree of public reproach.

The roads in the interior are generally indifferent. **Interior Commerce.** The common mode of travelling is by mules, by which means are transported to the towns on the coast cotton, sugar, coffee, grain, and the other produce of the country. In return are procured iron, steel, salt, woollens, cottons, common and finer earthenware, and glass. In the towns of the interior Mr Mawe saw all sorts of English goods, which were by no means dear.

The most remarkable incident in the recent his- **Settlement of the Court of Portugal in Brasil.** tory of Brasil is the emigration to its capital of the royal family of Portugal from Europe. In the long wars which have been recently concluded between France and Britain, it was obviously the interest of the minor powers, such as Portugal, to preserve a strict neutrality. But this was rendered difficult, as well as by the inveterate hostility of the two nations at war, as by the preponderating power which both had acquired on their respective elements of land and sea. Portugal, from her situation, was entirely exposed to the vast military power of France; and it was well understood, when France had gained the undisputed ascendancy in Europe, that the inferior states could only hope to purchase a nominal independence by acceding to, and rigorously executing within their territories, the system devised by Bonaparte, for the proscription of the British trade. The Court of Portugal, terrified by the menaces of so powerful a state, agreed, about the end of the year 1807, though with reluctance, to adopt that harsh system; but delaying, under various pretences, to seize the property and persons of British merchants, which was prescribed as an indispensable condition of her alliance with France, the French ambassador quitted Lisbon, which was the prelude to more decisive measures. A French army was directed to march against Portugal, and there being no resistance, it was rapidly advancing to the capital. In the meantime, war had been declared against England by the Court of Lisbon, a fleet had been fitted out, and all the severe measures dictated by France against Britain had been agreed to; but the secret connections of Portugal with this country were but imperfectly disguised by this affected hostility; and it had accordingly no effect in retarding the march of the invading army. In this emergency, it was resolved by the Court to escape the danger by embarking for Brasil, under the protection of Sir Sidney Smith, whose squadron was at that time blockading the mouth of the Tagus.

3 K

Brasil. This revolution was announced to the people by a royal decree. A council of regency was established, the public archives and treasure were embarked, the royal family followed, and on the 19th November 1806, the Portuguese fleet, joined by the English squadron, finally departed from Europe, and arrived at Bahia on the 19th January following. The royal family were received with every demonstration of attachment and respect; and the inhabitants of Bahia even offered to contribute a large sum of money in order to build a suitable palace for their reception, provided they would agree to reside in that place. Rio Janeiro, however, was thought more suitable for the residence of the Prince, and this capital, to which the court of Portugal soon afterwards removed, now became the seat of the Portuguese monarchy.

Effects of
the Emi-
gration of
the Court
of Portu-
gal.

In considering the emigration of the royal family of Portugal to Brasil, some speculative writers have indulged in the most fanciful anticipations of improvement from this event. They seem to have imagined, that the presence of the Supreme Government of Portugal in its colonies would revive the languishing industry of these countries; that it would remove the corruptions and abuses of their domestic administration; and that, by opening to them a free trade, it would enable them, in some degree, to rival the North American States in their rapid advances to wealth and improvement. But in order to realize those pleasing expectations, it would have been necessary that the Portuguese government, which was feeble and corrupt in Europe, should have totally changed its character in removing to Brasil, and this unhappily does not appear to have been the case. Abuses and corruptions still prevail in that country; the administration of justice is not amended—the royal monopolies for the sale of ivory, Brazil wood, diamonds, gold dust, gunpowder, tobacco, and snuff, are upheld in all their rigour; and, in general, the government is regulated upon the same principles as before. All the advantages of this translation of the government from the mother country to the colonies, seem therefore to be comprised in the commercial treaty connected with the measure; the effect of which is to open all the ports of Brasil to the vessels and produce of Great Britain, on payment of a duty of 15 per cent. The former system of restraint being removed by this treaty, there will thus be a greater stimulus to improvement of every sort; and industry, freed from the pernicious restrictions under which it formerly laboured, will be excited to new and active exertions by a higher price for its produce. These effects have accordingly, to a certain degree, taken place. We are informed by Mr Koster, who quitted Pernambuco in April 1811, and returned in the end of December in the same year, that, during this short interval, he observed a remarkable change for the better in the aspect of the place, and of the adjacent country. The houses had been greatly improved,—the ladies, in imitation of some families who had arrived from England and Portugal, began to walk abroad during the day,—the English fashions in clothes had become general among both sexes,—the equipages had assumed a gayer appearance,—a greater number of country residences had been

built,—lands had risen in price,—labour was in request,—and the adjacent grounds, which had been covered with brushwood, were now cleared, and were laid out for building and for gardens. Before Mr Koster quitted the country, in 1815, various other local improvements had been carried into effect; all which clearly indicate, that the free trade and the unrestrained intercourse with strangers, had diffused a general spirit of amelioration throughout this hitherto languishing community.

Owing to particular circumstances, the opening of the trade to the Brasils was not attended with the same beneficial consequences to Great Britain. At the period when this took place, all British goods were excluded from the Continent of Europe, by the edicts of France; the home-market was, in consequence, overstocked, and the British merchant was naturally anxious to find an outlet for his unsaleable produce. In these circumstances, the market of Brasil was suddenly thrown open, and such immense quantities of British goods were immediately poured into it, that it was completely overstocked. Prices fell proportionably; the goods were sold cheaper than they could have been bought or even manufactured at home; and, at last, they were accumulated in such excess, that the warehouses were not adequate to contain them. In many cases they were exposed on the quays to waste and speculation, or they were left to rot in warehouses ill-adapted for their reception. The loss and ruin consequent on these rash speculations, gave rise to numerous bankruptcies at home; and thus the commercial embarrassments of the country were rather aggravated than relieved by the opening of this new market for its produce. There can be no doubt, however, that a free intercourse with this extensive country, must ultimately create an increased demand for the manufactures of Britain, and must, in this view, be of permanent benefit to her commerce.

The military force of Brasil is composed of regular troops and militia. The regular army, which generally amounts to about 8000 men, is extremely ill regulated. It is badly clothed and poorly paid, and, owing to the disadvantages of the service, has to be recruited by impressment, a power which, under this despotic government, is exercised with the grossest partiality. The cavalry regiments which patrol the mining districts, are, however, highly respectable, both in point of discipline and equipment. The militia amount to upwards of 30,000 men; and to this service all are liable, with the exception of the first rate nobility.

The population of Brasil has been differently estimated. According to M. Beauchamp, it amounted in 1806 to 800,000 Europeans, 1,500,000 negroes, and to from 800,000 to 900,000 civilized Indians. This, however, appears to be an exaggeration. Sir George Staunton computes the number of whites at 200,000, and the blacks at 600,000; and some authors make the whole amount only to 420,000.

Histoire du Brasil, par M. Alphonse de Beauchamp. 8 tomes 8vo. 1815. *Mawe's Travels into the Interior of Brasil*, 4to. 1812. *Koster's Travels in Brasil*, 4to. 1816.

(s.)

Brass.

BRASS, in Chemistry and Manufactures, an alloy of copper and zinc. This name, however, has not been exclusively applied to the alloy of these metals; for the gun-metal, which has been also called brass, is an alloy of copper with tin. The same alloy, with more tin, is used in machinery, and is preferred to the alloy of copper and zinc, on account of its greater hardness.

Different kinds.

It appears from the analysis of the brass of the ancients, that it was an alloy of copper and tin. A small portion of tin gives to copper great hardness, and renders it capable of bearing much greater resistance. A larger portion of tin gives increased hardness, but is less fitted to bear a straining resistance, on account of its brittleness. Its elasticity is very great, which fits it for bells. In this state it is called bell-metal; with a still greater proportion of tin, it forms an alloy employed for the mirrors of reflecting telescopes. The alloy of copper with tin is easily distinguished from that with zinc from the agreeable colour of the latter, which varies with the proportions of the metals. Pinchbeck has the least proportion of zinc. Common brass has more zinc, and the gold-coloured alloy called Prince's metal, contains a still greater proportion of zinc. An alloy of copper with a very large proportion of zinc is used for the common white metal buttons.

Proportions of Alloys.

These various alloys of copper with tin and zinc forming the different kinds of brass, are to be considered as chemical compounds, and, of course, governed by the same laws of definite proportions which belong to the more conspicuous compounds.

On these principles, which cannot be doubted, we have an unerring rule for uniting these and other metals in the best proportions, the weights of their atoms being previously known. See the article **ATOMIC THEORY** in this Supplement.

The weight of the atom of copper being 8, tin 7.35, and zinc 4; the following table will exhibit the proportions of the various alloys, expressed in atoms, and their proportions by weight, the third column pointing out the colour and character of the resulting compound. CZ and T are to represent the atoms of the metals respectively.

COMPOUNDS OF ZINC WITH COPPER.

Atoms.	Proportions by Weight.	Character and Colour of the Compounds.
C+Z	1 to 2	The best proportions for common brass.
C+2Z	1 to 1	The alloy called Prince's Metal, of a beautiful gold colour.
C+3Z	2 to 3	Of a paler yellow, very little malleable.
C+4Z	1 to 2	Still of a lighter colour, and not malleable.
C+5Z	2 to 5	Yellowish white and brittle.
C+6Z	1 to 3	Very brittle, nearly white,
2C+Z	4 to 1	A very malleable brass used in watch-work.
3C+Z	6 to 1	An alloy much harder than copper and inclining to its colour.

COMPOUNDS OF TIN WITH COPPER.

Brass.

Atoms.	Proportions by Weight	Character and Colour of the Compounds.
T+C	11 to 12	A very brittle and rather white alloy.
2T+C	11 to 6	Still more brittle and more white.
3T+C	11 to 4	Very white, used for speculums.
4T+C	11 to 3	Coarse-grained and too brittle for any purpose.
T+2C	11 to 24	A yellowish alloy, very hard and sonorous.
T+3C	11 to 36	Bell metal.
T+4C	11 to 48	A very hard alloy used for some culinary vessels.
T+5C	11 to 60	Softer but not malleable.
T+6C	11 to 72	Still increases in softness and of a yellower colour.
T+7C	11 to 84	Used for some purposes in machinery.
T+8C	11 to 96	An alloy used for cannon.
T+9C	11 to 108	More common for cannon and machinery, and used for bronze statues.

Hitherto the proportions of these alloys have depended upon the caprice of workmen, obtained by numerous trials; and what confirms the law of definite proportions, is proved by the necessity of adhering to such fixed proportions, ascertained by trials. By attending to the stages of composition pointed out in the above table, the most striking and proper compounds will be produced, without the trouble of trying. Any proportions intermediate will, doubtless, be marked by defective colour, irregular crystallization, or imperfect malleability, in such as are expected to be so.

Although the most direct way of forming these different kinds of brass is by immediately combining the metals together, one of them, which is most properly called brass, was manufactured long before zinc, one of its component parts, was known in its metallic form. The ore of the latter metal was cemented with sheets of copper, charcoal being present. The zinc was formed and united with the copper, without becoming visible in a distinct form. The same method is still practised for making brass, which we are about to describe.

The materials used in making brass are, copper in Brass-making small rounded masses produced by passing the melted metal through an appropriate vessel into water, in which state it is called shot copper, and calamine, an ore of zinc. This latter substance is a carbonate of zinc, often containing some oxyd of iron, which gives it a reddish appearance. As it is chiefly found with lead, the lumps frequently contain more or less gallena, which requires to be separated by the same means employed for purifying lead ore. The calamine is first reduced to powder, and the lead is then separated by washing. When the calamine is separated, reduced to powder, and sifted, it is heated upon the hearth of a reverberatory furnace. This expels the volatile matter, which is principally water

Brass.

and carbonic acid. What remains is principally oxyd of zinc, abounding with some earthy matter, and probably much carbonic acid, which is not all expelled by the heat. The calamine thus prepared, charcoal powder, and copper, are the materials to be operated upon. The proportion in which they are mixed together, are equal weights of copper and prepared calamine, and $\frac{1}{10}$ their weight of powdered charcoal.

This mixture, intimately blended, is compressed into a crucible of the form of fig. 3. Plate XXXVI.* One of these crucibles holds about 100 lbs. of brass, when the process is finished; but as this consists of the pure copper and zinc, the pot, when charged, will contain of copper 66.3 lbs., of calamine 63. lbs., and of charcoal powder 13 lbs. When the crucible is filled, the contents should be covered with a mixture of clay sand and horse-dung, in order to defend the metals and charcoal from the action of the air. When this covering is strictly attended to, less charcoal powder might be employed; and a larger dose of the other ingredients might be put in its place, but it is generally the most defective part of the process. Having charged the pots, we will now describe the furnace which has to receive them.

Fig. 1. Plate XXXVI.* is a plan of the furnace. The part AB is taken at the level EF, showing the opening into the furnace on the ground floor at *a* and *b*: *c* and *d* are horizontal flues leading to the chimney *f*, and can be cut off from the same by the dampers seen in the dark part of the flue. CD, in the same figure, is a plan on the level GH, where the pots rest upon the cast iron plate on bottom *x*, *y*.

Fig. 2. is an elevation and section of the same furnace. AB shows a front view of the pyramidal chimney, and the archway opening into it. CD is a section of the same, through the middle of the fire-place II. R, P, Q, is a vaulted passage going across the building, and open at both ends, for the admission of air, which passes through the openings in the arch, through the fires. The bottom of the furnace is not a common grate, but a thick plate of cast metal, perforated with holes for the air to pass through; one hole being between each pot, as they are seen arranged in fig. 1. at I, I, and also in the section at *x*, *y*. When the pots are placed upon the plate, the fire is not placed immediately upon them, as it would not only derange them, but it would displace the covering. To prevent this, the pots are first covered by some dried heath, or common brambles. This lying on the pots, defends them for a time, when the fuel is thrown in. By the time the brambles are consumed, the coal will have coked upon the pots, and will act as a defence for the rest of the process. The fire is kept up from twelve to twenty hours at the Cheudle Brass Works in Staffordshire, where these drawings were taken from. They cast twice in the twenty-four hours.

The melted brass, after the refuse is skimmed off, is cast into ingots, if sold for melting over again, and into plates, if intended to be rolled into sheets, or made into wire. The plates are cast between large blocks of Cornwall stone. The lower stone is fixed, and the face made even and smooth, by filling up the recesses of the ruff stone with fine sand. The

Brass

Bread-fruit.

upper stone is similarly prepared, and is suspended over the fixed one. The height and breadth of the place to receive the metal is limited by iron bars laid on the lower stone. The upper stone is then let down upon the bars. The lower stone is a little longer than the upper one, and projects to the front. Being a little higher in that part, it forms a lip, or mouth-piece, to pour the metal into. The flat sides of the cast plate are therefore bounded by the surface of the stones, and the edges of the same by the bars above-mentioned. The ingot moulds are recesses in blocks of cast-iron, open on one side.

The most certain and correct method of forming brass and the other compounds expressed in the table above-given, is by immediately uniting the metals in given weights. It should, however, be observed, that it will be found difficult to introduce zinc into melted copper. The best way of uniting it with copper, in the first instance, will be to introduce the copper in thin slips to the melted zinc, till the alloy requires a tolerable heat to fuse it, and then to unite this alloy with the melted copper. (T.)

BREAD-FRUIT. Among the more valuable products of the warmer climates and the fertile islands of the southern Pacific Ocean, is to be ranked the bread-fruit, or *Artocarpus incisa* of botanists. Nature has favoured the tropical regions, and those countries in their vicinity, with inexhaustible quantities of the choicest vegetables, while the inhabitants of the north are restricted to shrivelled berries and meagre roots; and, if they have obtained a supply, always precarious, of some of the finer fruits, it is the result of patience, skill, and industry.

Ever since Europeans frequented the Eastern History of world in commercial enterprise, it is probable that its discovery. they were acquainted with the bread-fruit. How, indeed, could its properties be unknown to Quiros, who visited Otaheite so long ago as the year 1606? Yet the English navigator Dampier seems the first of the Europeans whose notice was particularly directed towards it, during his circumnavigation in the year 1688; and he expresses himself in these words: "The bread-fruit, as we call it, grows on a large tree, as big and high as our largest apple trees. It hath a spreading head, full of branches, and dark leaves. The fruit grows on the boughs like apples; it is as big as a penny-loaf, when the wheat is at five shillings the bushel. It is of a round shape, and hath a thick tough rind. When the fruit is ripe, it is yellow and soft, and the taste is sweet and pleasant. The natives of Guam use it for bread. They gather it, when full grown, while it is green and hard; then they bake it in an oven, which scorseth the rind, and makes it black; but they scrape off the outside black crust, and there remains a tender thin crust; and the inside is soft, tender, and white, like the crumbs of a penny-loaf. There is neither seed nor stone in the inside, but all of a firm substance like bread. It must be eaten new, for if it be kept above twenty-four hours, it becomes dry and eats harsh and choaky; but it is very pleasant before it is too stale. This fruit lasts in season eight months in the year, during which time the natives eat no other sort of food of bread kind. I did never see of this fruit any where but here (Guam). The natives told us that

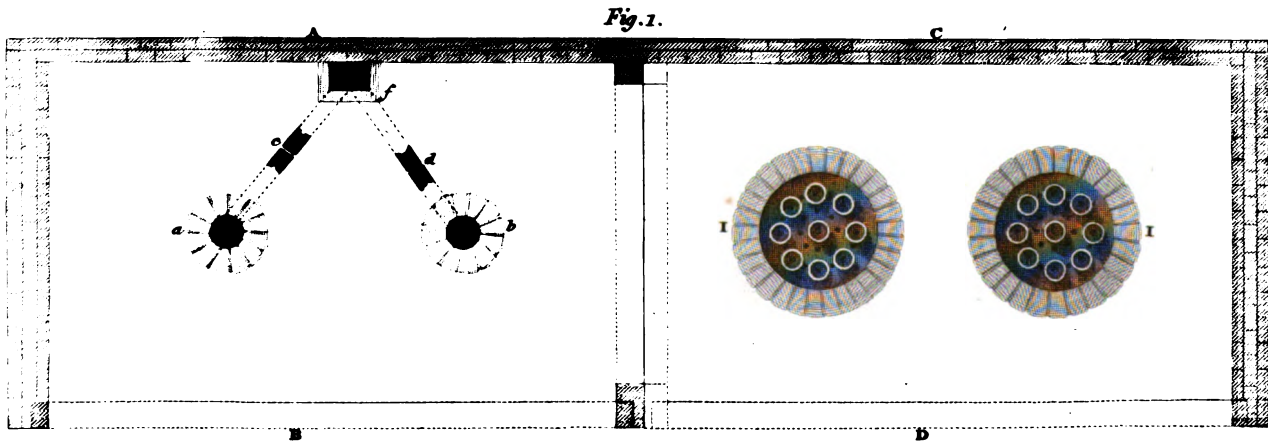
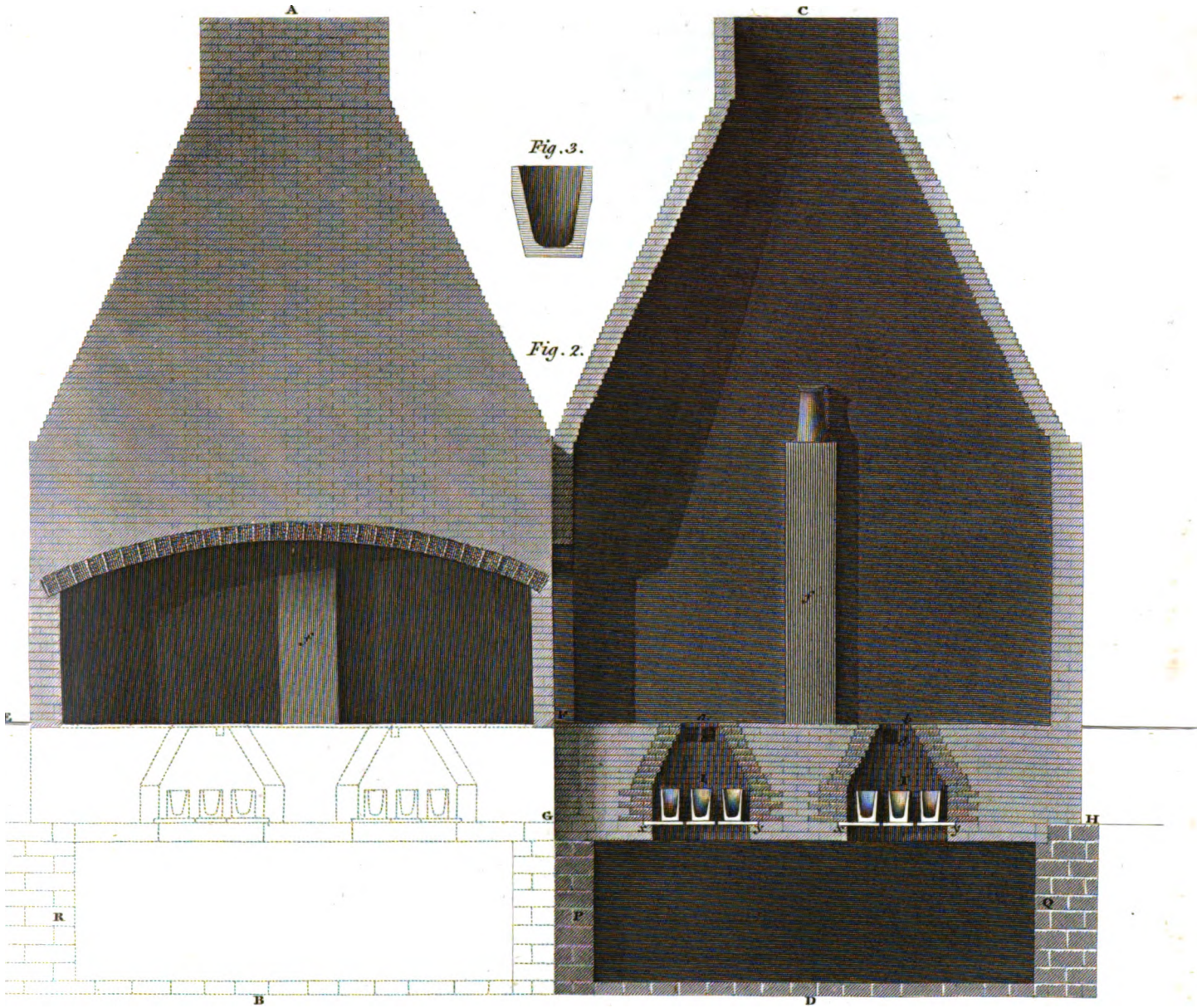

Scale of Feet.



Bread-fruit. there is plenty of this fruit growing on the rest of the Ladrone Islands, and I did never hear of it anywhere else." The bread-fruit, however, is found in still greater profusion, and in equal perfection, on many of the groups of islands scattered throughout the South Pacific Ocean; nor is it confined to them exclusively, but their soil and climate seem to correspond more intimately with the conditions of its vegetation.

Different Species. There are two leading species of this plant, which are characterized by the presence or absence of seeds; the latter being the preferable kind, and that which is cultivated more carefully for its produce. The natives of the South Sea Islands maintain, however, that eight different species, or rather varieties, may be distinguished, and for which they have the following names: Patteah, Eroroo, Awanna, Mi-re, Oree, Powerro, Appeere, Rowdeah. The leaf of the first, fourth, and eighth, differs from that of the rest; the fourth being more sinuated, and the eighth having a large broad leaf, not at all sinuated. In the first, also, the fruit is rather larger, and of a more oblong form, while in the last it is round, and not above half the size of the others. European observers, however, do not seem, in general, disposed to recognise these as essential distinctions, although they admit other varieties.

As Dampier observes, the bread-fruit is a large tree, growing to the height of forty feet or more. It is thick in the stem, and has a luxuriant foliage. The trunk is upright, the wood soft, smooth, and yellowish; and wherever the tree is wounded, a glutinous fluid exudes. The branches form an ample head, almost globular; the leaves are eighteen inches long, and eleven broad, resembling those of the oak, or the fig tree, from their deep sinuosities. The younger leaves, like all the more tender plants of the tree, are glutinous to the touch. The male-flowers are among the upper leaves, and the female flowers at the ends of the twigs. But it is the fruit which constitutes the value of the plant, and this is a very large berry, according to botanists, with a reticulated surface, resembling a cocoa-nut or melon in size and form, nine inches in length. It is filled with a white farinaceous fibrous pulp, which becomes juicy and yellow when the fruit is ripe; and the edible portion lies between the skin, which is green, and a core in the centre, which is about an inch in diameter.

Used as food to a great extent.

During a considerable portion of the year, the bread-fruit affords the chief sustenance of the Society Islanders. It is prepared after different fashions, and its taste depends in a great measure on the mode of preparation. It is insipid, slightly sweet, somewhat resembling wheaten bread mixed with Jerusalem artichokes, and some compare it to a cake made of flour, egg, sugar, milk, and butter. In general, it is cut into several pieces, and roasted or baked in a hole made in the ground, which is paved round with large smooth stones; and then it resembles a boiled potatoe, not being so farinaceous as a good one, but more so than those of ordinary quality. The stones are previously heated by a fire, kindled in the excavation, and the bread-fruit, being wrapped in a banana leaf, is laid upon them, and covered with leaves and hot stones. In Otahelie, and in the

West Indian Islands, several dishes are made of it; Bread-fruit either by thus baking it in an oven entire, when it is considered to equal or surpass any kind of bread; by adding water, or the milk of the cocoa nut, by boiling it, or forming it into a paste. This last is accomplished by taking the fruit before attaining complete maturity, and laying it in heaps, closely covered up with leaves, where it undergoes fermentation, and becomes disagreeably sweet. The core being then drawn out, the fruit or pulp is thrown into a paved excavation, and the whole covered up with leaves, whereon heavy stones are laid: it undergoes a second fermentation, and becomes sour, after which it will suffer no change for a long time. A leaven may be thus formed of it, which is baked as occasion requires. In the Island of Nukahiva, an agreeable beverage can be obtained from it, and in the West Indies it can be baked like biscuit, and will keep nearly as long. The fruit is in greatest perfection about a week before beginning to ripen, which is easily recognised by the skin changing to a brownish cast, and from small granulations of the juice. In the West Indies, it is soft and yellow when ripe, and is in taste and smell like a very ripe melon. Hogs, dogs, and poultry then feed on it readily.

Besides this, the bread-fruit-tree proper, there is one that has been long known in India and the Eastern Islands, of which the fruit contains from forty to an hundred farinaceous seeds, in appearance resembling chesnuts. These when roasted or boiled are more grateful to many persons than the bread-fruit, and the negroes are very fond of them. The external characters of the tree are scarcely to be distinguished from those of the other, and the chief distinction lies in the fruit, which attains nearly the size of that we have described, and is covered with prickles like a hedgehog. It grows from the seed with rapid vegetation, and attains larger dimensions than the proper bread-fruit-tree.

The natives of those islands producing this useful vegetable, collect it without the smallest trouble; ^{Its other uses.} they have only to climb the tree to gather the fruit. Nor is this the sole purpose to which it is converted, for they have a method of fabricating cloth from the bark; the leaves are substituted for towels, and the wood is employed in the construction of their boats and houses. A kind of cement and birdlime is also prepared by boiling the juice exuding from the bark in cocoa-nut oil.

It appears that there are other vegetables of this class, producing fruit of inferior quality, but ^{Its cultivation.} that account receiving less attention. The bread-fruit proper is of easy cultivation in its native soil. In some of the Islands it seems an indigenous product, and springs from the root of old trees, without any care; in others, it requires simply to be put into the earth. The trees flourish with greatest luxuriance on rising grounds; and it has been remarked, that where the hills of the Sandwich Islands rise almost perpendicularly in a great variety of peaks, their steep declivities, and the deep valleys intervening, are covered with trees, among which the bread-fruit is particularly abundant. It has also been observed, that although we are accustomed to consider Otahelie as of the greatest fertility in this plant, the trees of

Bread-fruit. the Sandwich Islands produce double the quantity of fruit. Though nearly of the same height, the branches begin to shoot out much lower from the trunk, and with greater luxuriance. In Otaheite, they are propagated by suckers from the root, which are best transplanted in wet weather, when the earth forms balls around them; then they are not liable to suffer from removal. This valuable plant is widely diffused in the Southern and Eastern Isles, and it is generally found throughout the great Pacific Ocean. It grows on Amboyna, the Banda Islands, Timor, and the Ladrões; but it is more specially the object of care and cultivation in the Marquesas, and the Friendly and Society Islands, where it vegetates in uncommon luxuriance and profusion.

Attempts to transplant it to the West Indies.

The great utility of the bread-fruit as an article of subsistence for mankind, has, at different times, led to speculations on the possibility of naturalizing it in places where it is not of spontaneous growth. M. de Poive, the philosophic Governor of the Mauritius, succeeded in introducing it there, and in the Isle of Bourbon, whither it was conveyed by M. de Sonnerat from Luçon in the Philippine Islands. Being found in the greatest luxuriance under the same latitudes as the British West India Islands, and in a climate not dissimilar, Government deemed the transmission of it thither, both as practicable without much difficulty, and as promising a future store of subsistence for the inhabitants. An expedition was therefore fitted out, with particular care, under the command of Captain, then Lieutenant Bligh, who sailed in the *Bounty* store ship, for the South Seas, in December 1787. This vessel was prepared so as to receive a great many bread-fruit and other plants, which would have proved a valuable acquisition to the colonists of the West Indies, and some which were expected to succeed under the culture of the curious in Great Britain. The *Bounty* arrived in safety at Otaheite, the principal place of her destination, and took on board 1015 bread-fruit plants, besides a great variety of different species of other plants, and after remaining twenty-three weeks, which were busily occupied, set sail on the 4th of April 1789. But it is unnecessary to say more of the expedition, which was rendered totally abortive by a mutiny ensuing three weeks subsequent to its departure; the cause of which still remains in obscurity. The Captain and eighteen adherents were barbarously turned adrift in an open boat, wherein they suffered incredible hardships, and, after a navigation of 3600 miles, reached the Island of Timor, having lost only one of their number, who was murdered by the savages of an intermediate Island. Notwithstanding the unfortunate result of this voyage, the object was still kept in view, and a new expedition planned with still greater precaution than the former; and it has been said that his present Majesty, King George III. took a lively interest in conferring so important a benefit on a distant part of his people. Captain Bligh having arrived in England, was appointed to the command of the *Providence* and *Assistance*, two vessels specially fitted out as before; and part of their complement consisted of two gardeners, to take the management of the plants col-

lected. The vessels sailed in August 1791, reached Van Diemen's Land in February 1793, and anchored at Otaheite in February following. Here they remained above three months, and obtained even a greater store of plants than formerly; for there were now 1281 pots and tubs, whereas the first number of the bread-fruit-trees, in 1789, did not exceed 887. Captain Bligh, in returning, made a dangerous voyage through Endeavour Straits, the exploring of which was part of his former instructions, and anchored at Coupang in the Island of Timor, where he substituted many other plants for those that had died. He then sailed for the West Indies, and, touching at St Helena, landed some bread-fruit plants, and took on board those of different species. The object of his voyage was at length completed by reaching the Island of St Vincent's in January 1793, where he committed 544 plants, of which 338 were bread-fruit, to the care of Dr Anderson, Superintendent of the Botanical Garden, and substituted for them 467 of different species, designed for his Majesty's garden at Kew. In the next place, Captain Bligh landed 628 plants, of which 347 were bread-fruit, at Port Royal in the Island of Jamaica, and replaced them with a farther collection for the King, with which he arrived in England on the 2d of August 1793. Five years and eight months had thus been occupied in accomplishing the desirable purpose of these two expeditions. But it belonged especially to Britain, by whom a familiar intercourse with the southern Islanders was first opened up, to effect an object of so much importance.

Nevertheless, some have been found inclined to challenge the wisdom of so difficult and expensive an experiment; both because the expectations of those who looked for an inexhaustible source of subsistence were not speedily realized; and because the places the best adapted for its culture already possess another vegetable, the plantain, which is much more grateful to the negroes, for whom the bread-fruit was principally designed. It has been argued, that the bread-fruit-tree requires considerable care in cultivation, that its progress to maturity is slow, though in Britain it would appear extremely rapid. Three years are required to reap the fruit; the plantain demands no care, while it produces its crop in fifteen months; thus giving it a decided preference in the opinion of the Colonist, who is always impatient for a return. Further, that whenever any vegetable, already relished by the inhabitants of a district, is completely established, they will always reject what they think less agreeable. These arguments have certainly had considerable weight; probably, however, from not duly appreciating the difficulties attendant on such an experiment as the naturalization of plants. But were we to take a retrospect of all the obstacles which have opposed the cultivation of many species of grain and fruits at present not uncommon in Britain, it would be very evident that success has resulted only from the most patient and laborious attention. Positive conclusions on this subject, are perhaps as yet premature.

In the year 1777, a premium was offered by the

Bread-fruit. Society for the Encouragement of Arts and Manufactures, to any individual who should bring the bread-fruit plant from the South Sea Islands in a state of vegetation to the West Indies, and the gold medal was awarded, in 1793, to Captain Bligh accordingly. That Society, with the laudable design of promoting its culture, continued to offer further premiums for the greatest number of plants raised in the British settlements; and in consequence a silver medal was awarded to Dr Anderson, Superintendent of the Botanical Garden at St Vincent's in 1798; and, in 1802, the gold medal to the Honourable Joseph Robley, Governor of the Island of Tobago. From the course adopted by these two Cultivators, the history of the bread-fruit has received much elucidation, and we shall comprise it in a few observations.

Result of
these at-
tempts.

Mr Robley received three plants from Dr Anderson in June 1793, which he planted in very deep rich soil, and paid them every attention, in hopes of procuring shoots. They flourished exceedingly, produced fruit in 1795, and continued to do so until autumn 1801, after which we have no notices respecting them. Being disappointed of obtaining suckers, Mr Robley applied to Dr Anderson, who advised him to lay bare some of the uppermost roots, and to wound them very deeply; and having followed these directions in October 1800, they almost immediately began to put forth shoots in abundance. In December, 120 fine plants were thus obtained, which Mr Robley placed in baskets containing about a gallon of good rich loose soil, and deposited them in the shade, in the vicinity of water. With this element also they were refreshed when the weather required it. Baskets were preferred to pots for the plants, from being lighter and more easily removed. Likewise, because when deposited in the place where they were ultimately to remain, the baskets would speedily rot, and not repress the growth of the plant, which would then extend its roots. European Cultivators would do well to attend to the beneficial use of baskets, for it too often happens that a tender plant is wounded in removing it from a pot, or that the earth surrounding it is so deranged and displaced, that no subsequent care can preserve it from destruction. Encouraged by the successful issue of these previous experiments, Mr Robley prepared a point of land of loose sandy soil, bounded by a salt lagoon and the sea, for receiving a large plantation. When the tide filled, brackish water was to be found everywhere at the depth of two feet and a half from the surface; but it had been observed in some of the South Sea Islands, that bread-fruit-trees grew in full vigour, though brackish water bathed their roots, and the point was otherwise defended from the encroachments of the sea by an artificial bank. The land being ploughed and harrowed twice, was divided into beds stretching across from the sea to the lagoon: the beds were 27 feet in breadth, and the plants put into the earth in the middle of each, and exactly at the distance of 27 feet asunder—thus leaving a large space for their vegetation. Mr Robley's expectations were not disappointed. In August 1801, he had 153 plants in a flourishing condition; and, prosecuting the object still

farther, he had, in the course of the subsequent year, 371 on the point of land, of which no less than 319 plants were in a flourishing, and some of them in a productive state. He transmitted specimens of the fruit to England preserved in vinegar, as it will not keep above two days after being taken from the tree; as also of the dried leaves and blossom. Other correspondents, nearly about the same time, sent specimens of cakes made from the bread-fruit converted to flour, which were extremely well flavoured; and it seemed that a dry nutritious food, resembling Tapioca in appearance and quality, might be prepared from it. The vegetation of this plant is very rapid. Ten of those committed to the care of Dr Anderson, in 1793, were about two feet high, and half an inch in diameter; and he observed, that, in the year 1798, most of the trees in the Botanical Garden at St Vincent's were above 30 feet high, and the stem two feet above the ground was from three feet to three and a half in circumference. From the remarks he was enabled to make in this interval on the varieties of the tree in the Botanical Garden, it appeared that the fruit came out in succession during the greater part of the year, but less of it between November and March than at any other time. The number produced by a single tree was very great, being often in clusters of five and six, and bending the lower branches to the ground. According to the different varieties, the fruit was of various shapes and sizes, weighing from four to ten pounds, some smooth, others rough and tuberculated. When taken from the tree before maturity, the juice appeared of the consistence and colour of milk, and in taste somewhat similar. It issued for above ten minutes in an uninterrupted stream, and thickened into a glutinous and adhesive substance. Three months were required to bring the fruit to perfection, which, as above remarked, is about a week before it begins to ripen. Besides the Otaheitan bread-fruit, Captain Bligh left some of the East India bread-fruit in the Botanical Garden. But this proved of infinitely inferior quality, and a very indifferent substitute for it. It was ill-shaped, of a soft pulpy substance, and, like the other, wanting seeds, and propagating itself by suckers springing from the root.

A species of fruit, bearing considerable analogy to those above described, is found on the Nicobar Islands, but we are unacquainted with the degree of attention it has received, either for the purpose of illustrating its natural history, or for economical uses. It is not less beneficial, however, to the natives. The tree producing this fruit vegetates promiscuously with others in the woods, but preferring a humid soil. Its trunk is straight, thirty or thirty-five feet in height, and from ten inches to two feet in circumference. The roots spring from it above the surface, and do not penetrate deep into the earth. The leaves are disposed like the large calyx of a flower; they are three feet long and four inches broad, of a dark green hue and tenacious substance. A long time elapses before the tree produces fruit, not less than about the period of human life. It then forms at the bottom of the leaves, from which it proceeds as it is enlarged, and, when nearly ripe, it changes from green to yellowish colour. This is the proper

Bread-fruit
||
Break-
water.

period for gathering it, when its weight is between 30 and 40 pounds. The exterior surface is cut off, and the fruit is boiled in earthen pots covered with leaves, during several hours, on a slow fire; when, becoming soft and friable, the preparation is sufficient, and the fruit is then exposed to the air, and is next formed into a mass not unlike maize, either in taste or colour. It may be preserved a long time, but exposure to the atmosphere occasions acidity. The plant producing this fruit, however, is not of the same genus as those above described, although its fruit is converted, to similar uses, but is rather a kind of palm which it might be useful to naturalize in the eastern possessions of Britain. (s.)

BREAKWATER, is any obstruction of wood, stone, or other material, as a boom or raft of wood, sunken vessels, &c., placed before the entrance of a port or harbour; or, any projection from the land into the sea, as a pier, mole or jetty, so placed as to break the force of the waves, and prevent their action on ships and vessels lying at anchor within them. Thus, the piers of the ancient Piræus and of Rhodes; the moles of Naples, Genoa, and Castellamare; the piers of Ramsgate, Margate, Folkstone, Howth, and the wooden-dike de Richlieu, thrown across the port of Rochelle, may all be denominated *Breakwaters*. In French it is sometimes called *Battre d'Eau*; a name which appears to have been applied to the mole at Tangier, a work commenced in 1763, under the direction of Lord Tiviot, Sir J. Lawson, and Sir Hugh Cholmley, and finished, or rather discontinued, in 1776, after having cost this nation the sum of L. 243,897, 5s. 4½d. The term *Breakwater*, however, has, of late years, been considered as more peculiarly appropriate to large insulated dikes of stone, whether of regular masonry or sunk promiscuously in rough masses, so placed, as to form an artificial island across the mouth of an open roadstead, and thereby, from obstructing and breaking the waves of the sea, to convert a dangerous anchorage into a safe and commodious harbour for the reception of ships of war or merchantmen.

Of this description of dike, for creating an artificial harbour on a grand scale, fit for the reception of ships of war of the largest class, there are two remarkable examples in the Breakwater of Cherbourg and that of Plymouth,—the one after thirty years of almost uninterrupted labour still very far from being completed; the other, in the course of about four years, in a much more forward state, and if necessary, capable of being completed in the course of two years.

Break-
water of
Cherbourg.

BREAKWATER OF CHERBOURG. In M. de Cessart's *Description des Travaux Hydrauliques*, will be found a very minute and laborious detail of all the preparatory operations, the progress and the expence of constructing the Breakwater of Cherbourg, up to the period of the Revolution. But the history of this great undertaking is summarily stated in a report made to the National Assembly in 1791, by M. de Curt, in the name of its Committee of Marine, concerning the Marine Establishment of Cherbourg.

Its History.

It had always been a source of considerable annoyance to the French (and more particularly since the demolition of the works and basin of Dunkirk,

Break-
water.

which cost them more regret than the useless and expensive projects for that port ever could be worth), that while the whole line of their coast, bordering on the English Channel, presented only sandy shores with shallow water, or an iron-bound coast bristled with rocks, Nature had lavished on their "eternal rival" of the opposite coast, the incalculable advantages of a succession of deep and commodious harbours, or of safe and extensive roadsteads, inviting their possessors to commerce and navigation, and placing in their grasp "the sceptre and the sovereignty of the seas." M. Curt observes, that "the misfortunes of La Hogue, which all the talents of Tourville could not prevent, taught Louis XIV., that, in completing the defence of his frontiers by land, he had too much neglected his frontiers on the sea; that this great prince, however, profiting by experience, soon discovered that England owed the superiority of her marine to the military establishments which she possessed in the Channel." With a view of securing to France similar advantages, the Marechal de Vauban was directed to visit the coasts of Normandy, for the purpose of adopting measures for placing in security, against hostile attacks, all such bays, harbours, and inlets, as were favourable for the disembarkation of troops; and to furnish plans of such works as he might judge to be necessary, not only for military, but for naval purposes. Among other projects, he reported that the roadstead of Cherbourg possessed the means of attack, of defence, and of protection; that it was very capable of exerting an influence on maritime war, and in their commercial relations with the northern powers; that it was the spot on which the head-quarters should be established on the coast of the Channel; and, in short, that it was a central advance post with regard to England. He moreover reported, that it might be made a port for the safe retreat of a squadron crippled by stormy weather, or beaten by an enemy, or even for the reception of a victorious fleet with its prizes. By thus converting the present exposed roadstead of Cherbourg into a safe and protected anchorage for a fleet of men of war, France, he said, would be able to watch the motions of England; to oblige her at all times to keep a corresponding fleet in the Channel; and to menace her shores with invasion of which she at all times stood so much in dread.

Opinions, however, being divided between the advantages of La Hogue and Cherbourg, Louis XVI., immediately after the conclusion of the American War, issued his directions to M. de Castries, Secretary of State for the Marine, to appoint a special commission, to consider and report which of these two roadsteads combined the most advantages, and was, in all respects, preferable for constructing a port and naval arsenal capable of receiving and equipping from 80 to 100 vessels of war of different descriptions. The Commissioners had little hesitation in deciding upon Cherbourg, because, by means of a Breakwater, it would be capable not only of admitting a fleet to ride securely at anchor when thus sheltered from the sea, but also of affording them protection against any attempt of an enemy. It was added, that Cherbourg was an admirable place for watching Portsmouth, without appearing to have

Break-water.

once recollected what an excellent anchorage Spit-head was for watching Cherbourg.

Directions were accordingly given to M. de Caux, Commanding Officer of Engineers at Cherbourg, to commence, as a preparatory measure, with the construction of a fort on the Island of Peleé, and another on Du Homet, according to plans given in by Vauban in 1679; by these works the roadstead would be flanked on the right and left. The interval, however, being found too great to afford sufficient protection to all the ships that might require to be anchored in the roadstead, M. de Caux presented a plan to the Minister at War for constructing an intermediate fort in the sea, which should be casemated, and sufficiently large to contain all the buildings necessary for a garrison. The surrounding walls were proposed to be sunk in caissons of 6000 feet square at the base, and 52 feet high. The top of the platform was to be 80 feet high from the bottom of the sea, and the area of its surface 1000 square toises. This plan, however, was not considered to give sufficient shelter to a fleet from the winds and waves, and new projects were called for by the Government.

In 1777, M. de la Bretonniere, Capitaine de Vaisseau, one of the commissioners who had been named to report on the comparative merits of the two roadsteads of Cherbourg and La Hogue, had addressed a memorial to the Minister of Marine, in which he expatiated, at great length, on the numerous advantages held out by the former, and particularly with regard to the security of the anchorage. He proposed to construct, at the distance of a league in the sea, a stone dike of 2000 toises in length, leaving three open passages into the roadstead it was intended to cover; one in the middle, and one at each extremity. This dike, like that which was sunk before Rochelle, was proposed to have as its nucleus a number of ships filled with masonry, floated off and sunk in proper situations, and afterwards to be cased with large sunken stones, to the height of 50 feet above the bottom of the sea. The reason assigned for sinking the stone vessels was the supposition that an under current might cause so much motion at the bottom of the sea as would derange the level, and work away the loose stones; so little appears at that time to have been known of the increasing tranquillity of the waves of the sea, in proportion to the increasing depth of water.

On this plan the commissioners observed, 1. That in order to construct a dike of 2000 toises in length, with sloping sides proportioned to its height, there would be required so great a number of old ships as could hardly be collected in all France in less than ten years; and, if purchased from foreigners, the expence would be enormous. 2. That the assembling and employing the necessary number of seamen would be next to impossible, but, if possible, highly impolitic, when, just at the close of a maritime war, commerce felt a pressing want of their services; whereas it might be practicable, and would be advantageous, to employ the military for some time before disbanding them. 3. That no comparison would hold good between the roadstead of Cherbourg with an opening to the sea of 3600 toises, and

VOL. II. PART II.

Break-water.

a depth of 40 to 42 feet of water at the lowest ebb, and the closing up the entrance of the port of Rochelle, which is only 740 toises in length, and the depth of water only five or six toises. 4. That the upper part of the projected dike, being exposed to the violent action of the sea, the stability of that part could not be depended on; and besides, a dike covered at high spring-tides with 18 feet water would not fulfil the two indispensable conditions—smooth water, and protection against an enemy. These arguments were deemed conclusive, and the plan of M. de la Bretonnieré was abandoned.

In 1781, M. de Cessart, Inspector-General of Bridges and Embankments, received directions to prepare a plan that should cover a fleet of 80 to 100 ships of war in the roadstead of Cherbourg, from the attack of an enemy, and protect them against the elements. M. de Cessart was fully aware that, to raise a barrier in front of this roadstead, and in the middle of the sea, capable of resisting the impetuosity of the waves, and repelling the enterprises of the enemy, was no easy task. "Nothing," says he, "that I had ever performed, or that I had ever read of, in ancient or modern history, appeared to me to be worthy of being placed in comparison with the grandeur of this project." He suggested, as the preferable and only mode of answering the purpose of producing smooth water in the roadstead, that, in the place of one continued dike or mole, a number of large masses, separated from each other, of a circular form, with an elevation greatly inclined, should be substituted; in short, a series of truncated cones, which, touching each other at their bases, might present to the sea at the surface, alternate obstacles and openings, and thus interrupt and break down the waves previous to their entering the harbour. He also considered that, as these openings at the surface would not exceed 72 feet, a sufficient barrier would be formed against the passage of an enemy's vessel; and that, if necessary, in time of war, it might be rendered still more secure by placing strong chains of iron across the intervals. It was proposed to construct these conical caissons, of wood, the number of which to cover a front of 2000 toises would amount to 90, which, at 360,000 livres for each cone, would cause a total expence of 32,400,000 for the whole. The number, however, was afterwards reduced to 64, and the time estimated for completing the work 13 years. Each cone was to be 150 feet in diameter at the base, and 60 feet in diameter at the top, and from 60 to 70 feet in height, the depth of water at spring-tides, in the line in which they were intended to be sunk, varying from about 56 to 70 feet. They were proposed to be sunk without any bottoms in them, by which the upward resistance of the water acting on a base whose surface was equal to 17,678 square feet, would be avoided. The caissons floated off by caaks, attached to their inner and outer circumference, being towed to the spot where they were destined to be sunk, were then to be filled with stones to the tops, and left for a while to settle; after which the upper part, commencing with the line of low water, was to be built with masonry laid in pozzolana, and encased with stones of granite.

This plan of a stone dike or Breakwater being

3 L

Break-
water.

laid in detail before the Minister of Marine, it was deemed proper, on a subject so entirely novel, and of such great national importance, to consult the ablest men in France, before any steps should be taken for carrying it into execution. The details were accordingly submitted to the four commissioners, M. de Borda, a naval officer and Member of the Academy of Sciences; M. de Fleurieu, Capitaine de Vaisseau, and Director of Ports and Naval Arsenals, afterwards Minister of Marine; M. Peronnet, Member of the Academy of Sciences, Chief Engineer of Bridges and Embankments; and M. de Chezy, Inspector and Director of the School of Engineers. They recommended that, in the first instance, an experimental cone should be constructed, and floated off. Instead, however, of 60 feet in height, the cone made at Havre was only 36 feet; the circumference of its base 472 feet, and having a slope of 60 degrees; the upper circumference was 339 feet. Within the exterior cone, and at the distance of 5 feet 10 inches from it, was an interior and concentric cone, bound together by beams of wood, pointing to the common centre, each being the section of the radius. The frame of each cone was composed of 80 large upright beams, 24 feet long and 1 foot square. On these were erected 80 more, of 14 feet in length, making in the whole 320 of these large uprights; the machine was then planked, hooped, and firmly fixed together with iron bolts.

The cone at Havre being completed, the next operation was to tow it off to the particular spot where it was to be sunk. Being open at the bottom, it was found necessary to attach to the lower circumference 284 large casks, part to the exterior and part to the interior cone; besides 50 casks, attached by lines of equal lengths, from the bottom of the inner circle, to float towards the centre, and thus assist in keeping it upright and steady. It was easy enough, by these means, to float off a vessel of this kind. M. de Cessart observes, that the force of 7200 pounds produced by a capstan, was found sufficient to draw it on the water, to a distance equal to the length of its own diameter, or about 25 toises, in two minutes.

"The success of the experiment made at Havre," says M. Curt, "had inspired such veneration for the conical caissons, that those persons who had been most disposed to object to the plan, were now obliged to be silent." The result of the experiment at once decided the Government to commence operations at Cherbourg. M. de Cessart was appointed director of the works, with four Engineers to assist him. A permanent council, consisting of Commanders in Chief, Directors, Engineers, &c. was ordered to reside, for six summer months, at Cherbourg, and the other six in Paris; and a considerable body of troops were marched down to the neighbourhood, to furnish a competent number of artificers and labourers, to be employed on this great national undertaking.

In 1788, the buildings were commenced for lodging the principal officers of the civil and military departments, and their respective establishments; a naval yard marked out and inclosed,—roads of communication opened with the forts,—and at Becquet, about a league to the eastward of Cherbourg, a small harbour was dug out for the reception of about 80

vessels, which were to be employed in transporting the stones from thence by sea.

On the 6th June 1784, the first cone was floated off and sunk, and the second on the 7th July following, in presence of 10,000 spectators, assembled on the shores and quays of Cherbourg; but before the cavity of the latter could be filled with stones, a storm, in the month of August, which continued five days, entirely demolished the upper part of this cone. In the course of this summer the quantity of stones sunk within the cavities of the two cones, outside their bases, and in the intermediate space, amounted to 4600 cubic toises, or about 65,000 tons.

In 1785, three more cones were completed and sunk at irregular intervals; and, at the end of that year, the quantity sunk amounted to 17,767 cubic toises, or about 250,000 tons. In 1786, five additional cones were completed and sunk; one of them in presence of the King; and the quantity of stones thrown within them, and deposited on the dike connecting the cones, amounted, at the end of this year, to 42,862 cubic toises, or 600,000 tons. In 1787, five more cones were sunk and filled with stones, making, in the whole, fifteen; and the distance between the first and fifteenth cone was 1203 toises, and the quantity of stones deposited within these cones and the connecting dike, at the end of this year, amounted to 71,585 cubic toises, or more than 1,000,000 tons. The violent gales of wind that were frequent in November and December, carried away all the upper parts of the five cones which were sunk this year. In 1788, three more were sunk, but the upper parts of the first two were carried away as the others had been; the height of the third was, therefore, reduced, so as to be, when sunk, on a level with low water; but this cone was upset and soon went to pieces.

The enormous expence, and the delay that had been occasioned in completing and sinking these eighteen cones, exhausted the patience of the Government, so that, in the following year, 1789, it caused the three cones, then on the building slips, to be sold for whatever they would fetch.

The total quantity of stone that was sunk within the cones, and on the intermediate dike, from the year 1784 to the end of December 1790, being seven years, amounted to 373,359 cubic toises, or about 5,300,000 tons.

These 18 cones being sunk at irregular distances from each other, some being 25 toises, and others at 300 toises from centre to centre, occupied a line of 1950 toises in length. The distance of the first cone from the Island Pelée, on the east, was 510, and of the eighteenth to Fort Querqueville on the west 1200 toises; so that the whole entrance or opening of the roadstead of Cherbourg was originally 3660 toises, more than one-half of which was now imperfectly covered by the breakwater.

The expence of this great undertaking was not, we suspect, accurately known, and could not, probably, be ascertained. M. de Cessart estimates the eighteen cones alone, at 6,231,407 livres, or about L. 260,000; and the total expence incurred between the 1st April 1788 and the 1st January 1791, he states as under:

Break-
water.

Break-water.		Livres.		
The value of the materials of the cones	-	2,462,369	9	6
The value of the workmanship	-	1,560,560	9	9
The conveyance and sinking of stones	-	14,880,074	2	5
Incidental expences for buildings, magazines, &c.	-	2,359,489	5	0
Contingent expences	-	395,926	13	4

Making the general total 21,658,420 0 0 or L.900,000 Sterling. In this estimate the extra pay to the troops and seamen employed, would not appear to be included; for M. de Curt, in his report to the National Assembly, states the total expence to have amounted to 32,000,000 livres, or L. 1,300,000 Sterling; and that a farther sum would be required of 879,648 livres, to bring the top of the dike to an uniform height, namely, a little above the level of the surface, at low water, of ordinary tides.

The number of people employed was prodigious. To enable M. de Cessart to complete and sink five cones a-year, he found it necessary to employ 250 carpenters, 30 blacksmiths, 200 stone-hewers, and 200 masons,—in all 680 artificers. The number of quarrymen, and others, employed in transporting 174,720 cubic toises of stone for the 64 cones originally intended, or 13,650 yearly, was estimated at 400 workmen, 100 horses, 30 drivers, 24 chasses-marées, each carrying seven cubic toises, or about 98 tons, with 100 seamen; making an aggregate, for this service, of 526 men, and for the whole operation from 1200 to 1500 artificers and labourers, to which were actually superadded about 3000 soldiers.

A very considerable part of the expence might have been saved by dispensing altogether with the cones, all of which burst, as might have been expected from the superincumbent weight of a deep column of water, pressing the stones within against their sides. The 9th cone, which was sunk in 1786, went to pieces in 1800, after standing fourteen years; another reached the duration of five years; six remained on an average about four years; and all the rest went in pieces within a year from the time of their being sunk.

The failure of the cones, and the breaking out of the Revolution, put an entire stop, for some time, to all operations at Cherbourg. The attention, however, of the National Assembly was speedily called to what they considered to be an object of great national importance. In 1791 they directed their Committee for the Marine to make out a detailed report of the operations that had already been carried on. On this report being given in by M. de Curt, in the name of the Committee, it was read and approved by the Assembly, and funds to a certain extent decreed, to complete the undertaking on a new plan proposed by M. de Cessart. The principal feature of this plan was that of casing over the surface of the dike as it then stood with large blocks of stone; and to carry the height of the breakwater along the whole of its extent, so far above the high water mark of spring-tides, as to render it capable of receiving batteries on the summit, at the middle, and at the two extremities.

The slope of the side next to the roadstead was found on examination to sustain itself unaltered at an angle of 45 degrees, but the slope on the side next to the sea, whose base was three for one of height, had given way to the depth of fourteen feet below the low water mark; and the materials being composed of small stones, were washed away, and had formed themselves into a prolonged slope of one foot only in height for ten feet of base, which was therefore concluded to be the natural slope made by the sea when acting upon a shingly shore; a conclusion, however, too vague to be correct, as the slope occasioned by the action of the sea must depend on the nature of the materials against which it acts, and the force and direction of the acting power. A sandy beach, for instance, has invariably the most gradual slope, gravel the next, shingles the next, and large masses of rock or stone, the most precipitous. At the present time, the stones of the breakwater, by constant friction, have worn away the sharp angles, and it has been found that the base on the side next to the sea is on the average fully eleven for one of perpendicular height.

It was proposed, therefore, to cover the side with a coating of stone 12 feet thick, to consist of blocks of 12, 15, 20, and 30 cubic feet, or from one to two tons each, which casing was to be carried to the height of 12 feet above the high water mark of the highest spring-tides; the size of the stones to increase towards the summit, so as to be capable of resisting the percussion of the waves, which is there the strongest. It was calculated that this covering of 12 feet thick on both sides would require for each toise in length 70 cubic toises of stone, and that the whole length of the dike would consequently require 136,500 cubic toises, which, by deducting for the vacant spaces between the stones, would be reduced to 113,750 cubic toises of stone, or about one million and a half of tons. It was farther calculated, that the expence of quarrying, the transport to the quays, the loading, conveyance, discharging machinery, together with the commissioners, clerks, &c. would cost for each cubic toise deposited on the dike the sum of 55 livres, which for 113,750 cubic toises, would amount to 6,256,250 livres, and, adding for contingencies 600,000 livres, the total estimate amounted to 6,856,250 livres.

The machinery employed for thus casing the breakwater may be seen in Plate XXXVII., in which

Fig. 1. Represents a section of a lighter on which it is erected.

AZX is an elevated deck or platform.

Y, three rollers of six inches diameter.

TK, two beams or sheers, moving on trunnions in grooves at T.

S, hooks to hold the sheers at the proper angle of inclination.

L, the axle of the windlass or wheels B, round which the rope of the pulleys passes. The wheels are 12 feet in diameter.

Fig. 2. A chase-marée laden with blocks of stone.

E, the block and its hook laying hold of an iron chain round a stone.

F, the stone hoisted to the platform AZ, (fig. 1.) when the brace is unhooked at S; the hoisting con-

Break-water.

tinued until the summit K of the sheers is brought to V, when they rest against the frame which supports the windlass; the stone F is then lowered upon the rollers as at M, from whence it is pushed forward by men to the inclined plane, off which it is rolled into the water upon the side of the dike.

It was calculated that, by employing a certain number of these machines, 34,090 toises might be deposited in one year, reckoning only six working months, or 5682 toises *per* month, or that 487 superficial toises of the dike might be covered in one season, and the whole completed in four years. Very little progress, however, had been made at the commencement of the war in 1803. At that period the centre of the dike only had been brought above the high water mark, in which was placed a battery and a small garrison of soldiers, the whole of which were swept away by a heavy sea, occasioned by a tremendous gale of wind in the year 1809, when all the buildings which had been erected on this part of the breakwater, the men, women, and children which composed the garrison, together with several workmen, were washed away; at the same time, two sloops of war in the roadstead were driven on shore, and dashed in pieces. This disaster was such as might have been expected. The effect of sinking large stones upon the small ones, already rounded by constant attrition, could not be otherwise; the latter acting as so many rollers, carried out the former even beyond the extremity of the base, to which the breakwater had naturally been brought by the action of the sea.

At present small spots only are visible above the surface of the sea at low water of spring-tides, and no where such spots exceed three feet in height; the intermediate spaces are from 3 to 15 feet below the surface; and, taking the average, the whole dike, from one end to the other, may be about four feet below the surface of low water at the spring-tides. Near the middle, however, there is about 100 yards where the height rises to 18 or 20 feet above high water, but it exhibits only a shapeless mass of ruins. In one spot a large heap of stones has been accumulated, as if to try how much weight might safely be trusted upon it, before the attempt be made to rebuild the fort. The largest of the stones in this mass may be about four tons, and they descend to the size of 200 or 300 pounds.

Of the remainder of the dike, very few parts are visible at low water; and, at this moment, the greater part is four feet below the surface of low water; it is sufficiently high, however, to break the force of the waves, and to make the port of Cherbourg a safe anchorage in some winds for about 40 sail of the line.

On the renewal of the war, after the rupture of the treaty of Amiens, Bonaparte began to bestow a greater share of attention on the navy of France; and though, for a time, the unparalleled victory of Trafalgar checked his efforts, it did not induce him to abandon them. His plans were vast, and, at the period of his fall, were in rapid progress towards their completion. He had determined on a fleet of 200 sail of the line, and the noble port of Antwerp gave him every facility for ship-building. For the better security in forming a junction of his two great fleets of Brest and Antwerp, Cherbourg now became

more valuable, as a convenient port of retreat in case of accident; but it had no dock-yard, nor means of giving to a ship a large refit or repair. He might have thought too, as we believe most of our naval officers do, that a fleet of ships, riding at anchor behind the breakwater, are easily attackable by fire-ships, as the same wind which carries a vessel in at one entrance will carry her out at the other, and the course would lie directly through the centre of the fleet at anchor. Besides, it might be possible, in certain winds, under the lee of the centre part of the breakwater, to bombard a fleet at anchor in the roadstead within it.

He determined, therefore, to establish a large dock-yard at Cherbourg, not merely for repairing, but also for the construction of the largest class of ships of war; to dig a basin that should contain 50 or 60 sail of the line; to construct dry-docks and slips for building and repairing, and to make it a naval port of the first rank. In 1813, this basin was completed at an expence, as Bonaparte is said to have asserted when on board the *Northumberland*, and which has since been confirmed, of L. 3,000,000 Sterling. A wet-dock of the same magnitude, communicating with it, was then commenced, and is now in progress.

The only description that we have been able to find in print of this great work, which took ten years in carrying into execution, is contained in a short letter from M. Pierre-Aimé Lair, Secretary to the Society of Agriculture and Commerce of Caen, who was present at the ceremony of opening and consecrating the great basin, in presence of the Empress Maria Louisa, the 27th August 1813. He describes this basin to be excavated out of a rock of granite schist, or gneis, the density and hardness of which increased as the workmen descended from the surface. He compares it to an immense trough dug out of a single stone, and capable of containing many millions of cubic feet of water. We now know, however, that Mr Lair is mistaken; that it is not one mass of rock, but rock and gravel mixed; that the whole of the sides are cased with a well constructed wall of red granite; and that a noble quay, built of the same material, and extending between the two forts of Galet and Homet, separates the basin and wet-dock from the sea.

The dimensions of the new basin he states to be about 900 feet in length by 720 in width, and the average depth 55 feet from the edge of the quay; and as this edge is five feet above the high water mark of the equinoctial spring-tides, the depth of water in the basin is then 50 feet, and the mass of water, after making allowance for a slope of the solid sides inward in an angle of 45° from the height of about 25 feet, amounts to about 30 millions of cubic feet; and that it is calculated to contain about 30 sail of the line. We have reason to think that it is considerably larger; about 1000 feet by 770 feet, and consequently contains a surface of about 18 acres, which, at three *per* acre, will contain 54 sail of the line, and the adjoining wet-dock, when finished, an equal number. The latter is at this time about two-thirds completed, and from 300 to 400 men are employed in blasting the rock and building granite walls. The dike or breakwater seems to be abandoned; the

Break-water.

Break-water. works having long been stopped, and the stone vessels going rapidly to decay. The French officers say, indeed, that it has occasioned the roadstead to become shallower, by the deposition of sand that has taken place.

The entrance canal leading from the outer harbour into the basin is at right angles to the latter, and its direction ENE. Its dimensions are as under :

	Feet.	In.
Width between the two moles in the direction of their axis, - - -	196	8
Width at its opening into the basin, - - -	308	8
Length from the axis of the moles or piers to the line of wall forming the side of the basin, - - -	274	0

The basin, having no gates, is said to be excavated to the depth of nine feet below the bottom of the canal, the former having, as before mentioned, 50 feet water, and the latter only 41 at high spring-tides, which, as they ebb 20 feet, would leave only 21 feet in the passage or canal at low water. This inequality, we presume, is intended to keep the ships afloat in the basin at low water, when the depth in the canal is not sufficient for that purpose; but after so much expence incurred in digging the basin, one would suppose a little more might have been expended in digging the canal to the same depth, so as to let ships pass into and out of the basin in all states of the tide; an advantage of the utmost importance for speedily securing their ships in the basin, when in danger of an attack from the enemy in the roadstead, or of speedily putting to sea and escaping the vigilance of a blockading squadron. No reason is assigned for leaving the basin without gates; but we suspect that Mr Lair is again mistaken, and that the passage has depth of water sufficient for ships of the largest class to run into the basin at all times of the tide. But even here they do not lie in safety; for the wide entrance facing the NE. is covered only in that direction by the Isle Peleé, so that the water in the basin partakes of the swell in the road, which is sometimes so great as to make it necessary to apply 10 or 12 cables to hold ships steady in the basin.

Another serious inconvenience is likely to arise from this particular construction of the basin. Whatever silt or mud is carried in by the tides must be deposited there, and cannot possibly escape. The quantity is probably not very great in the water of the Channel opposite to Cherbourg, but, higher up, towards Ostend, it is very considerable. When we took possession of that port, it was found that, in the course of the Revolutionary war, the harbour, by neglect, was filled up with six or seven feet of mud.

Several pieces of cannon are intended to be mounted on the two piers, to protect the entrance into the basin. On one of them is likewise placed a light-house, and on the other a Semaphoric telegraph. Four slips of granite, for building large ships, were at this time constructed on the southern side of the basin; and on each of them was a ship of the line in progress, L'Inflexible of 118 guns, Le Centaure of 80, Le Jupiter and Le Genereux of 74 guns each. Two other ships of the line were on the stocks

without the dock-yard, nearly ready for launching, Le Zelandais of 80, the first line of battle ship laid down at Cherbourg, and the Duguay-Trouin of 74 guns; and in the roadstead were Le Polonais and Le Courageux. In the centre of the same side of the basin, with two slips on each side of it, a noble dry-dock was cut out (or built rather) of solid granite, in which ships of the largest class might be built or repaired. Its dimensions were,

	Feet.	In.
Length, - - -	230	
Width, - - -	74	
Depth, - - -	26	6

Thus the ships built on the four slips may be launched into the basin, and at once docked out of it.

But few store-houses, or other buildings necessary for a naval establishment, are yet erected; but there is an ample space laid out for every purpose that can be required to make Cherbourg one of the first naval arsenals in Europe; and a narrow canal, between the walls of Fort du Homet and the wall of the wet-dock, leads to a most convenient space for mast-ponds and mast-houses.

The fortifications for the protection of the anchorage in the roadstead, and the new naval arsenal, are, 1. Querqueville. 2. Fort du Homet. 3. Fort du Galet. 4. Fort Royal, on Isle Peleé. Fort Royal, and Fort du Homet, have circular faces towards the sea, with each two tiers of guns, and turrets above them; the former mounts about 80 guns, the latter 65, and Querqueville about 30 guns.

The principal channel from the road to the sea is at the western end of the breakwater, which, for large ships, is not more than half a mile in width; and this want of space will always make it difficult for ships of the line to work out; but, on the other hand, a fleet may push out to the westward in southerly winds, which lock up the English ports in the Channel.

The eastern channel is a very indifferent one; and, from the position of the Isle Peleé and the main, is likely to become worse, from the accumulation of sand, which the French officers say is actually the case.

Such, as are here described, were the mighty preparations of that extraordinary man for the destruction of the naval power of Great Britain, and, with it, of the national glory, pride, and prosperity; which, whether elated with success, or depressed by reverses, he never attempted to conceal as being the object nearest to his heart; and he had sufficient cause for his hatred, well knowing that it was England, and England's navy, that opposed the only obstacle between him and the subjugation of the world to his dominion.

To give the greater eclat to this grand undertaking, he sent the ex-Empress Maria Louisa to be present at the opening of the basin. When the time arrived for the water to be let in, and the dam broken down, her approach was announced by flourishes of warlike music and numerous discharges of artillery. "Cries of joy," says M. Lair, "were mingled for a long time with the thunder of the batteries. Her Majesty took her place in the pavilion which had been prepared for her, when the Bishop of Contances, surrounded by his clergy, advancing towards

Break-water.

Break-water.

Break-water.

her, pronounced an address suitable to the occasion. After the ceremonies and customary prayers, he turned round towards the basin, and blessed this work of man. It is delightful to see a nation consecrating by religious rites an event so memorable, and causing the divinity to intervene in all its grand undertakings." He speaks with rapture on the gratification he derived from seeing men born on the shores of the Tiber, and on the banks of the Guadalquivir, working under the direction of French engineers, at the establishment of a port in the channel, formidable to the English navy; and suffers no expression of regret to escape him at the idea of these poor Italian and Spanish prisoners of war being compelled to labour in chains at a work, for which they were neither paid, nor in which they could take the least possible interest.

Break-water in Plymouth Sound.

BREAKWATER IN PLYMOUTH SOUND, is a work of a similar nature to that of Cherbourg, but constructed on sounder principles, with less machinery, and fewer people. Compared in extent and dimensions with that of Cherbourg, it is only in the ratio of about one to four.

There is no port and harbour on the south-west coast of England possessing so many advantages as Plymouth,—none so well situated for assembling and equipping a fleet to watch the movements of the enemy in the harbour of Brest. Its dock-yard may be considered as the second in the kingdom in point of size, convenience, and effective strength; the margin of which stretches along the magnificent harbour of Hamoaze, a noble expanse of water, nearly land-locked, of a capacity sufficient for mooring safely a hundred sail of the line in excellent anchoring-ground, and in water that carries its depth to the very quays of the yard. On the opposite or eastern side of the Sound, and at the distance of about three miles from Hamoaze and the dock-yard, is another sheet of water, called Catwater, not quite so deep, nor so well sheltered as Hamoaze; but, since the progress made in the Breakwater, forming a safe and commodious harbour for merchant vessels of every description. These two harbours open into Plymouth Sound and Cawsand Bay, in which ships employed in the blockade of Brest, or those refitted in Hamoaze, have been accustomed to assemble and prepare for putting to sea. But the very exposed situation of Plymouth Sound, and the heavy swell that almost constantly rolled in, especially when the wind blew fresh from the south-west to the south-east, made it so inconvenient and so unsafe an anchorage for ships of the line, that, of late years, the fleet employed in blockading Brest, has been in the practice of bearing up, when driven from its station, for the more distant anchorage of Torbay, though little better with regard to security, and worse in every other respect, than Plymouth Sound. It is, for instance, a more ineligible rendezvous for the western squadron, in the chance of the fleet being caught there by an easterly wind, and unable to get out, when it is the most favourable wind for the enemy to put to sea; in the danger to which the ships are liable when so caught at an anchorage, so open and exposed; in the inconvenience, the delay, and the expence of obtaining the necessary supply of stores and provisions from the

other ports, there being none at Torbay;—in short, this open and exposed bay bore so bad a character among naval officers, that Lord Howe used to say, it would one day be the grave of the British fleet.

Break-water.

It is, besides, an object of the first importance to the efficiency of every naval arsenal, to have a safe and commodious roadstead in its neighbourhood, like that of Spithead to the harbour and dock-yard of Portsmouth. Here those ships which may have gone through a course of repair or refitment, or those new from the stocks, may assemble and complete their final equipment for sea; and here, also, ships returning from sea may safely lie at their anchors, till the wind and tide may serve them to go into harbour. But, in Plymouth Sound, ships coming out of Hamoaze, or ships going into that harbour, had no such security: by the rolling sea that set in, they were exposed to the double danger of parting their cables, or striking against the hard and rocky bottom, either of which would be almost certain destruction.

It was most important, therefore, to render Plymouth Sound, if possible, by any means, and almost at any expence, a safe roadstead for ships of war. To ascertain the practicability of this measure, Mr Rennie, the Civil Engineer, and Mr Whidby, the Master Attendant of Woolwich Dock-yard, were sent down by Lord Howick, at the suggestion, we believe, of Lord St Vincent (Earl Grey), in the year 1806, with directions to examine and report, whether by any, and by what means, a sufficient shelter might be given to insure a safe anchorage for a fleet of ships of the line. The report was favourable; and several plans were offered for sheltering this sound, so as to render it capable of containing in safety at their anchors, above 50 sail of the line. Nothing, however, was done or attempted, notwithstanding all the increased and mighty preparations of the enemy, till Mr Yorke presided at the Board of Admiralty; when one of his first measures was to carry into execution this grand and important national object,—the most important that, perhaps, was ever undertaken for the glory and the safety of the British navy. The delay that took place can only be explained by the frequent changes of the Board of Admiralty, which, we believe, have been fatal to many important measures for the benefit and advantage of this great bulwark of the nation.

Of the plans proposed for sheltering the sound, one was to throw a pier from Stadon point to the Panther rock, of 2650 yards in length; another, to construct a pier from Andurn point to the Panther, of 2900 yards; and a third, to carry a pier from the same point to the Shovel rock, being only 900 yards.

The objection that was urged against throwing out piers from either of these points, and abutting against the shore, was principally grounded on the certain effect they would have of changing the current of the flux and reflux of the tide to the opposite side of the sound; and of increasing its strength and velocity on that side, while it left all calm on the other; the inevitable consequence of which would be, a deposition of mud or silt in the calm part or eddy, which, in process of time, would shallow the water, already not too deep, to such a degree as to unfit it for the reception of large ships of war.

Besides, of the three passages for large ships into

Break-
water.

Plymouth Sound from the sea, the two best are those on the two sides; the worst was that in the middle. Either of the plans, therefore, which proposed piers to be thrown from the mainland, must have destroyed one of the best passages, and left the worst open, which was nearest to the anchorage behind the proposed pier. The middle passage might, in fact, be almost considered as shut up against very large ships by the St Carlos and the Shovel rocks; whereas, if this middle passage should be shut up altogether, it would rather serve to deepen, by giving an increased velocity to the tide, which would scour out the bottom, than to shallow, the two side passages.

On these considerations, Messrs Rennie and Whidby proposed, that an insulated pier or Breakwater should be thrown across the middle of the entrance into the sound, having its eastern extremity about 60 fathoms to the eastward of St Carlos rock, and its western end about 300 fathoms west of the Shovel, the whole length being about 1700 yards, or close upon a mile; stating, with confidence, that such a Breakwater might, with every chance of success in its favour, be constructed; and that it would give shelter to ships in the sound, without any danger of lessening the depth of water.

The middle part of the Breakwater was proposed to be carried in a straight line for the length of 1000 yards; but they recommended that the length of 350 yards at each end should have an inclination towards the straight part, in an angle of about 120°. See the *figure*, Plate XXXVIII. These inclined ends would not only give shelter to a greater extent of the sound, but would, in a greater degree, prevent the rushing in of the tide from agitating the water at the anchorage, than if the two extremities were left in the same straight line, and at right angles with the direction of the current into the sound.

It was also proposed, in order to cover the sound more effectually, that a pier should be thrown from Andurn point towards the principal Breakwater, of about 800 yards in length, with the same inclined point of 120° as the head of the Breakwater. This pier, however, does not appear to have been thought necessary, and might have been in some respect injurious to the sound. It might, however, have made Bouvisand Bay a good anchorage for frigates and smaller vessels, and given them the advantage of a fine stream of fresh water, which falls into that bay.

It was recommended, as the most practicable and best mode of constructing this great work, to heap together promiscuously large blocks of stone, which were to be sunk in the line of the intended Breakwater, leaving them to find their own base, and take their own position; and it was conceived that stones of the weight of one and a half to two tons each would be sufficiently large to keep their places, without being rolled about by the tremendous swell which, in stormy weather, is thrown into Plymouth Sound, and thus avoid the inconvenience and loss of time and labour which the French experienced at Cherbourg, by throwing down small rubble stones. It was thought, that, in those places where the water was 5 fathoms or 30 feet deep, the base of the Breakwater should not be less than 70 yards broad,

Break-
water.

and the summit 10 yards, at the height of 10 feet above the low water of an ordinary spring-tide; that is, the dimensions of the Breakwater, in those places, should be 40 feet high, 30 feet across the top, and 210 feet wide at the foundation.

The surrounding shores of Plymouth Sound and Catwater were next examined, with a view to determine from what quarter materials for this great undertaking could most conveniently be obtained, as to quality, cheapness, and celerity of conveyance. On the west or Cornish side of the sound, nothing appears but hard granite; at the head of the sound and in Catwater, on the Devonshire side, all is marble and limestone. In Catwater alone, it was estimated, on a rough calculation, that 20 millions of tons might be procured in blocks fit for the work, which was about ten times the quantity that would probably be wanted. The time required for the completion of the work, would depend on a variety of circumstances. It is obvious that, if the two sides of the sound had furnished proper materials for the purpose, the time would considerably have been abridged, as, in that case, when the wind was easterly, vessels might deposit stones on the eastern end of the Breakwater, and in westerly winds, on the western extremity, and the work would thus be proceeding with an uninterrupted progress; whereas, if the stone was to be brought from one point, and that point on the shore of Catwater, a strong southerly and south-westerly wind, those most prevalent in this country in the winter months, would generally impede and frequently render it impossible for vessels to go off with their cargoes.

Catwater, however, having many advantages, and especially for the convenience of loading the vessels, and the facility of procuring blocks from the quarries of any size, was considered, on the whole, as entitled to the preference over any other place. Besides the quarries here being in the neighbourhood of villages, lodgings and conveniences would be afforded for the workmen; and, on the whole, it was calculated that the work might be completed from hence at a cheaper rate, and perhaps in less time, than from situations much nearer to it, but much more exposed to the wind and waves.

An estimate of the expence could not be made with any degree of accuracy, as no correct section of the bottom had been taken. Supposing, however, the great Breakwater to be 1700 yards in length, 30 feet in width at the top, when carried 10 feet above low water of spring-tides, with a slope on the southern or sea side, of three horizontal to one perpendicular, and, on the sound or land side of one and a half horizontal to one perpendicular, it was calculated that the whole mass of stone required, would be about two millions of tons. If then 100 sail of vessels of 50 tons burthen each were employed in carrying stone, and that each vessel was to carry only 100 tons a week, the quantity deposited in one week, would amount to 10,000 tons, or say 500,000 tons a year; and, at this rate, the Breakwater would be completed in four years; but making allowance for time lost in preparations, contingent delays and unfavourable weather, and deductions in the quantity of stone for the shallow parts over which the line of

Break-water.

the breakwater was carried, the completion of the work might safely be calculated within the period of six years.

Nor would the building of the pier from Andurn point, if so determined, increase the time of completion. If carried from the shelving rocks within the point, leaving a passage between them, the pier would require about 360,000 tons of stone, which, by employing about 30 vessels, might be deposited in three years.

It was recommended by the gentlemen above mentioned, that the great Breakwater should be begun on the Shovel and extended on both sides of it, as, by so doing, the effect produced on the sound would be observed as the work proceeded; and that buoys should be placed along the line, so that the whole of the vessels employed might, if necessary, deposit their cargoes at the same time without interrupting each other.

The rough estimate for completing this great national work, made on the grounds above stated, was as follows:

Estimate of the Probable Expence of a Breakwater and Pier for the Sheltering of Plymouth Sound and Bouvisand Bay.

2,000,000 tons of limestone, in blocks, from 1½ to 2 tons weight each, for the great breakwater, at 7s. 6d. per ton,	L.750,000	0	0
360,000 tons in the pier, proposed to be built from Andurn point, at 7s.	126,000	0	0
Contingencies, say at 20 per cent. on the whole,	175,200	0	0
Total for the Great Breakwater,	L.1,051,200	0	0

Estimate of the Probable Expence of a Cut-Stone Pier and Two Light-houses to be built on the top of the Great Breakwater.

42,000 cubic yards of masonry, in the out and inside walls of the pier, at 27s.	L.44,700	0	0
62,000 cubic yards of rubble filling between the out and inside walls, at 6s.	18,600	0	0
Paving the top of the pier with large blocks of stone, \$500 square yards,	22,950	0	0
Two light-houses, with reflectors, and argand lamps,	5,000	0	0
Contingencies 20 per cent.	28,650	0	0
	L.119,900	0	0
Breakwater,	1,051,200	0	0
Total Estimate of completing the works,	L.1,171,100	0	0

It was not before the opinions of the best Engineers, men of science, and naval officers eminent in their profession, had been collected, compared,

Break-water.

and seriously considered, that Mr Yorke determined to carry into execution this great undertaking. The principal objection started against it was that it might cause the anchorage in the Sound to be destroyed in the course of time by the deposition of mud and silt along the whole eddy within it. There does not, however, appear to be any solid ground for this objection. The water brought by the tides from the sea is at all times perfectly clear and transparent, and that which proceeds from Hamoaze and supplied by the Tamar and the Tavy, is almost wholly free from any alluvial matter, these rivers holding their course through a fine granite soil. The fact is sufficiently proved by the circumstance of no deposition taking place in the recesses of Hamoaze along the dock-yard wall, which lead into the docks, nor in the numerous eddies that are caused by the projecting jetties and salient angles of that wall. Another objection started against the undertaking was that, by the diminished quantity of water thrown in by the tide into Hamoaze and Catwater, the Sound would gradually fill up and these harbours be destroyed. No perceptible alteration, however, has as yet taken place in the height of the water in Hamoaze, or in the strength or set of the tides.

A rock of limestone, or rather gray marble, situated at Oreston, on the eastern shore of Catwater, consisting of a surface of 25 acres, was purchased from the Duke of Bedford for the sum of L.10,000; quays for shipping the stone were erected in front of it; iron railways leading from the quarries to the quays were laid down; ships were hired by contract to carry off the stone, and others built at the dock-yard. Mr Whidby was appointed to superintend the work. The quarries were opened on the 7th August 1812; the first stone deposited on the 12th of the same month; and, on the 31st March 1813, the breakwater made its first appearance above the surface of the Sound at low water of the spring-tide. The system of quarrying the stone is conducted with admirable skill, and stones of the proper size obtained with less waste of small rubble than might be expected. In working these quarries an extraordinary phenomenon was discovered in the very body of the great mass of this old marble rock. At the depth of 65 feet from the summit of the rock, and 25 from the margin of the sea, a cavity, or rather a nodule of clay was discovered, of 25 feet long and 12 square, or thereabouts, in the midst of which were found several bones of the rhinoceros, in a more perfect state, and containing less animal matter in them, than any fossil bones that have yet been dug out of rock or earth.

The vessels employed for carrying off the large blocks of stone, are of a peculiar construction, adapted to convey, with ease, masses of marble weighing from three to five tons each. These great blocks of marble are placed on trucks at the quarries, and run down from thence, on iron railways, to the quays, against which the vessels lie with their sterns. The two stern ports are made sufficiently large to receive the trucks with the stones upon them. Each truck is passed separately through the port-hole, on an inclined plane, and run to the fore-part of the vessel, in the hold, on an iron railway.

Break-water.

The two sides of the hold of the vessel are calculated each to contain eight of these loaded trucks, which, at five tons on each truck, gives 80 tons of stone for one cargo. The stones thus placed on the trucks remain till the vessel arrives at the point in the line of the Breakwater where they are to be deposited. By means of a crane on the deck of the vessel, the two trucks nearest to the two stern ports are then drawn up the inclined plane, and run upon a frame on moveable hinges, called the *typing-frame*; by the falling of this frame, in the manner of a trap-door, the stone or stones are discharged from the trucks on the slope of the Breakwater; but the typing-frame remains, by means of a catch, in the position in which it is left at the moment of discharging the stones, until the empty truck is pulled up by the crane to the after-part of the deck, from whence it is run forward to make room for the second pair of loaded trucks in the hold. The catch being now disengaged, the typing-frame returns to its former position, ready to receive the next pair of loaded trucks, and so on till the whole sixteen have been discharged, and the light trucks run upon the deck of the vessel, ready to be run out at the quay, and from thence to the quarries, to take in fresh loads of stone. In this manner a cargo of 80 tons may be discharged in the space of 40 or 50 minutes. The vessels are placed in the proper places for depositing the stones by means of buoys, and the exact line of the Breakwater is preserved, by observing lights or staves placed at a distance on the shore.

The following description, referring to Plate XXXIX., will convey an accurate idea of these excellent vessels for the purpose they were constructed.

Fig. 1. Shows the stern of the vessel, in the act of depositing the stones. The runner R being hooked to the fore-part of the truck, raises it up, and by that means tips the stone overboard. When the stone is in the act of being drawn up out of the hold, on the inclined plane B (fig. 3.), the runner is hooked to the fore-part of the truck, and lashed down to the after-end, over the stone, which prevents the latter from sliding off the truck, in its progress up the inclined plane. The empty trucks are, for the most part, lodged on the fore-part of the deck, and some placed on an edge against the side of the vessel.

Fig. 2. Shows the stern of the vessel when loaded, with the ports up, or closed.

Fig. 3. A longitudinal or sheer-section of the vessel, when loaded, with the trucks on one side of the hold and deck, showing the number which the vessel usually stows on each side. The stones being frequently longer than the trucks, the number carried in the hold must be proportioned accordingly. In bad weather it is unsafe to send many trucks on deck; and, in general, not more than four are sent into the Sound, in that way, at one time; the amount of the cargoes, therefore, vary according to circumstances, from 40 to 65 tons; the largest stone hitherto deposited being about eight tons.

The after-part of the deck, under the tiller, is divided into two parts, length ways, and made to move up and down; the fore-parts are secured to a beam

VOL. II. PART II.

by hinges. This moveable deck, when raised, as at X, allows the stones to come out of the hold; and, when down, as at Y, serves to convey the empty truck from the port to the deck, in order to make room for another stone.

D Is a common windlass for heaving the trucks out of the hold up the inclined plane B.

C The hinges of the typing-frame.

Ten vessels of this construction, for carrying large masses of stone, built in the King's Yards, and forty-three hired by contract, averaging about fifty tons each, are employed in conveying stones from the quarries. The contractors' vessels are not of the same construction as those in the immediate employ of government; they carry stones of less weight, which are hoisted out of the hold by a chain and windlass, and thrown overboard. A load of fifty tons is discharged from one of these vessels in about three hours. By all these vessels, the quantity of stone deposited in 1812 was 16,045 tons; in 1813 71,198 tons; in 1814, 239,480 tons; in 1815 264,207; and in 1816 up to 12th August, 206,033 tons; at which time, the total quantity of stone sunk, amounted to 896,968 tons; and at the conclusion of the year to upwards of 1,000,000 tons.

Of this quantity, the proportions of the different sizes of the blocks deposited are nearly as follows:

	Tons.
Of one ton each stone and under	423,904
— one to three tons each	309,706
— three to five tons each	150,593
— five tons and upwards	12,760

The original contract price for quarrying the stone was 2s. 9d. per ton, and the original contract price for conveying it to the Breakwater 2s. 10d. per ton, since which the former has been reduced to 2s. 5d., and the latter to 1s. 10d. per ton. The cost of each ton of stone sunk in the Breakwater, including the building of quays, purchase of land, salaries, and every other expence, according to the nearest calculation that can be made, amounts to about 8s. 1½d., which, upon the whole quantity deposited, gives the total sum expended up to 12th August 1816, equal to L. 364,000. And as the work may be considered as more than half completed, it will be finished considerably within the original estimate, and, if parliament had thought fit to grant the money, within the time.

The greatest quantity of stone sunk in any one week was 15,379 tons; and the part of the Breakwater, at the above mentioned date, above the level of low water spring-tides, was in length 1100 yards. The length completely finished to the height of three feet above the level of the highest spring-tides, and thirty feet wide at top, was at the same time 360 feet. The large stones of the upper part of the Breakwater are deposited to any nicety by means of a vessel constructed for the purpose, having the same sheer or slope at the bow with the side of the work, so that by a projecting beam or mast, the largest stones can be taken out of the vessel, and placed on

3 M

Break-water.

Break-water.

the opposite side, or middle, or any other part of the Breakwater.

The small establishment, and the quick manner with which this great work has been carried on, form a curious contrast with the multitudes employed on the Breakwater of Cherbourg, the time occupied by that undertaking, and the parade and ostentation with which it was conducted.

The whole establishment for carrying on the Plymouth Breakwater is as follows :

	Persons.
A superintendent, with proper officers and clerks, to keep and control the accounts	10
Warrant officers and masters of the ten stone vessels in the immediate employ of the public	21
Seamen and boys to navigate these vessels	90
Seamen employed in the superintendents' vessels, the light vessel, boats' crews, &c.	45
Masons, blacksmiths, carpenters, sailmakers, and labourers, employed at Oreston	39
<hr/>	
In the immediate pay of Government	205
Seamen employed in the contractors' vessels	170
Quarrymen, labourers, &c. employed at Oreston by the contractors	300
<hr/>	
Total establishment	675

Beneficial Results of this Great Work.

The result of this great work has completely answered the expectation of its warmest advocates. The good effects of it were, indeed, very sensibly felt at the end of the second year, when about 800 yards of the central part, where the water was shallowest, were visible at low water spring-tides. The swell was then so much broken down and destroyed at the head of the Sound, that the fishermen were no longer able, as heretofore, to judge of the weather outside the Sound; and ships of all sizes, and, among others, a large French three-decker, ran in with confidence, and anchored behind the Breakwater. Since that, near 200 sail of vessels of all descriptions, driven in by tempestuous weather, have, at one time, found safe shelter within this insulated mole, where a fleet of 25 to 30 sail of the line may, at all times, find a secure and convenient anchorage, with the additional advantage of having a stream of excellent water from a reservoir constructed above Bouvisand Bay, capable of containing from ten to twelve thousand tons, or a quantity sufficient to water 50 sail of the line. This water is brought down in iron pipes to Staddon Point, opposite to the anchorage, where it is intended to build a jetty from which the water will descend through the pipes into the ships' boats. The whole expence of this most useful appendage to the Breakwater is calculated at about L. 16,000.

During the winter of 1816-7, the gales of wind were more frequent and tremendous than had been known for many years; and, on the night of the 19th January, such a hurricane came on as had not been remembered by the oldest inhabitant. The tide rose

six feet higher than the usual height of spring-tides.

The Jasper sloop of war, and the Telegraph schooner, being anchored without the cover of the Breakwater, were driven to the head of the Sound, and both lost; but a collier deeply laden, and under its cover, rode out the gale. No damage was sustained by any of the shipping in Catwater; but it was the general opinion, from former experience, that, if no Breakwater had existed, the whole of the ships therein must have been wrecked, and the storehouses and magazines on the victualling premises, and most of the buildings on the margin of the sea, been entirely swept away. Till this tremendous gale, the Breakwater had not sustained the slightest damage from the heavy seas that, through the winter, had broken against it with unusual violence, not a single stone having moved from the place in which it was originally deposited; but after the hurricane above-mentioned, and the high tide which accompanied it, it was found that the upper stratum of the finished part, extending about 200 yards, and 30 yards in width, had been displaced, and the whole of the huge stones, from two to five tons in weight each, carried over and deposited on the northern slope of the Breakwater. In no other part could it be discovered that a single stone had been displaced.

The want of a harbour, or any place of safety to which ships can resort in bad weather, or in distress, between the ports of Plymouth and Portsmouth, led to the suggestion of Portland Roads being converted into a secure harbour by means of a Breakwater. It was estimated that the construction of such a stone dike, extending from the north-east part of Portland Island, about two miles and a quarter in length, covering an anchorage of about four square miles, and completely sheltering the pier, harbour, and bathing place of Weymouth, would require about four million tons of stone, five years to complete it, and an expence of about six hundred thousand pounds Sterling. The capstone alone, which covers the Portland stone, and which, not being marketable, is not only useless, but a great incumbrance, would be sufficient to complete this great undertaking; and the elevation of the quarries, being 300 feet above the level of the sea, would admit of the stone being sent down on rail-ways to the water side, without the aid of either engines or horses; and, on this account, would be deposited at less than one fourth part of the expence which is incurred at the Plymouth Breakwater. Such a secure anchorage in this situation, in which the largest fleets, either naval or mercantile, would ride at anchor in all winds, and the most stormy weather, in perfect security, is not unworthy the consideration of the public; and, perhaps, in the present increased state of our population, and the difficulty of finding employment for the labouring poor, there can be no truer policy than that of carrying on great national works of public utility, were it only for the sake of encouraging industry, instead of expending an equal, or probably a far greater sum, for the support of idleness and the encouragement of vice, in those parochial buildings, too frequently miscalled work-houses. (κ.)

Break-water.

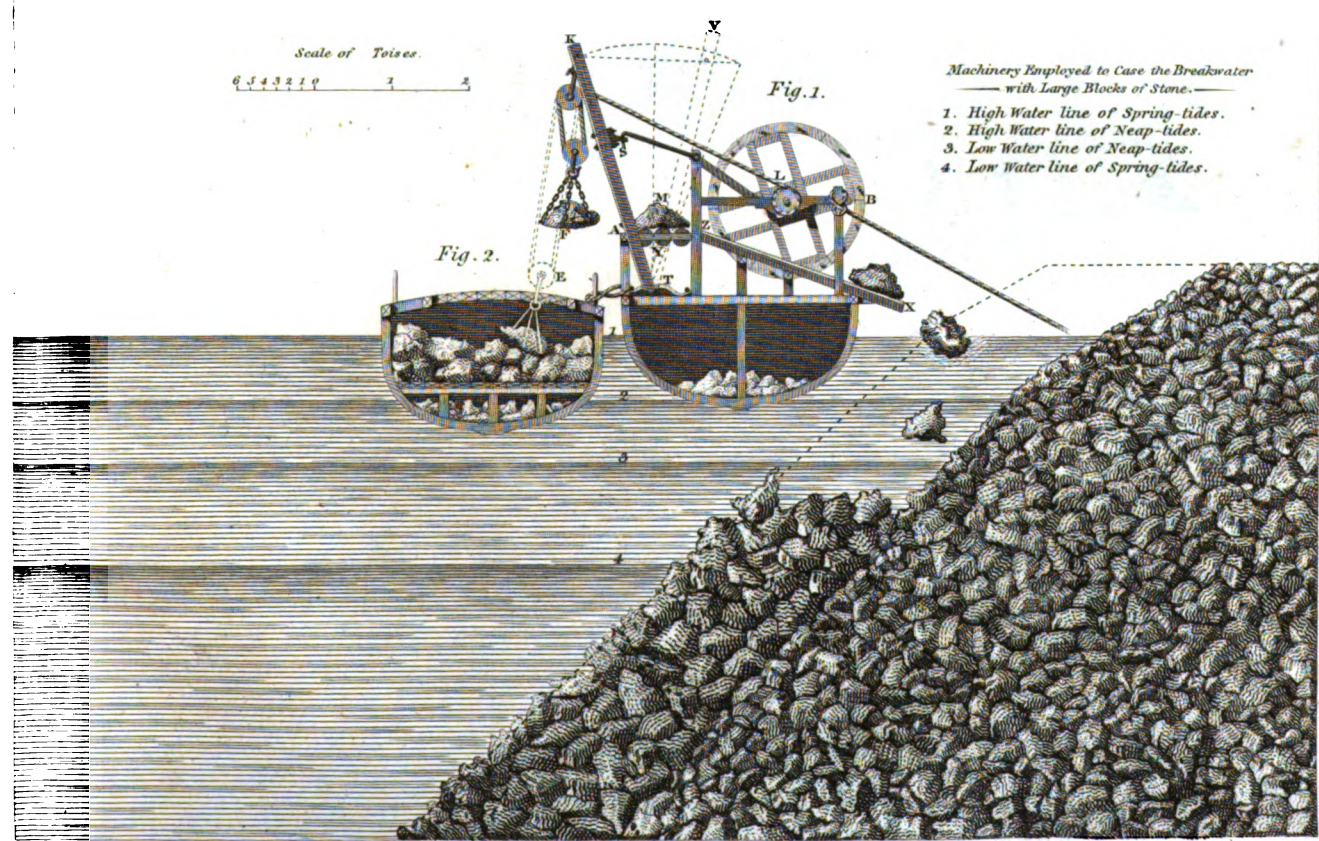
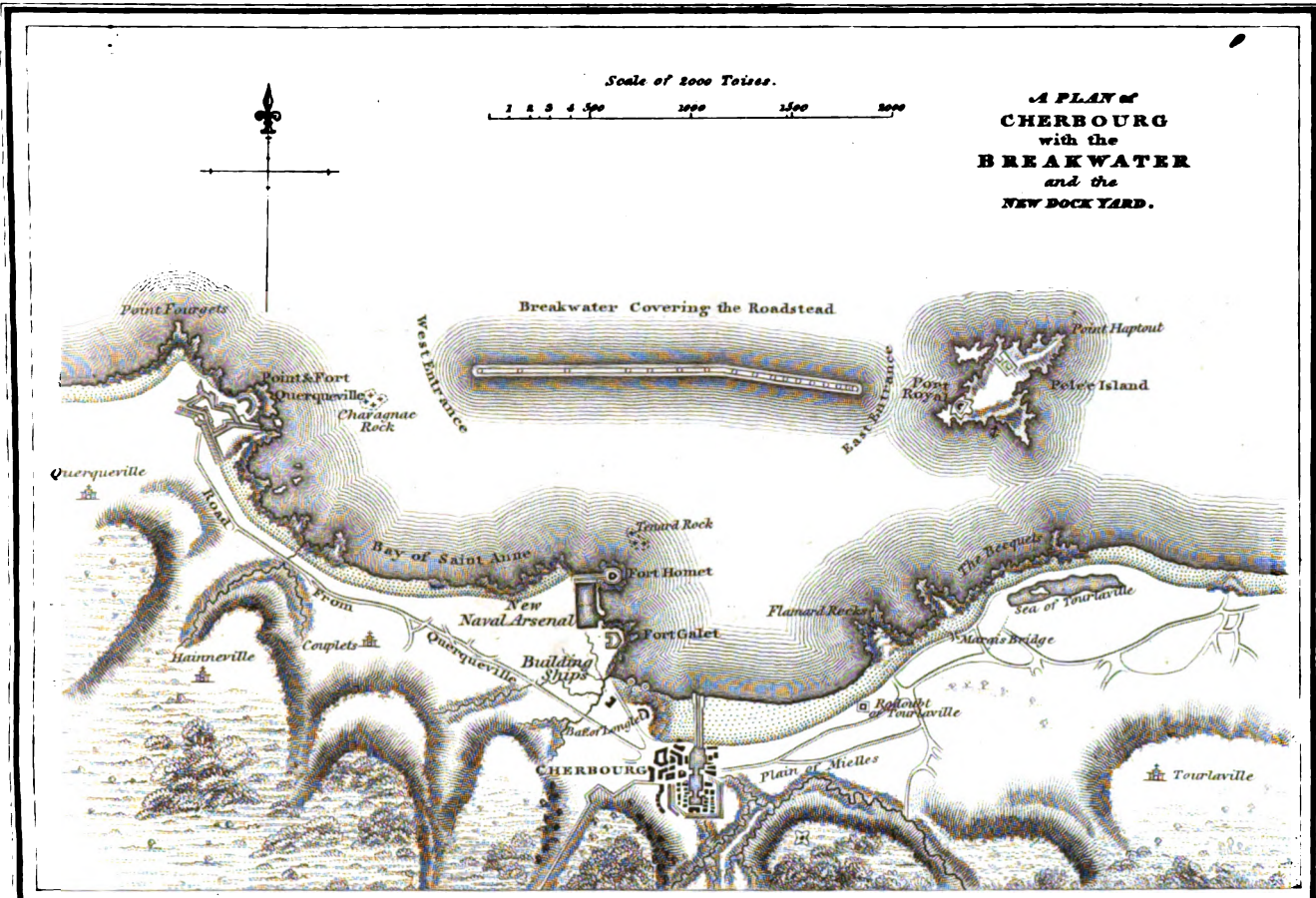

SKETCH of PLYMOUTH SOUND.



TRANSVERSE SECTION of the FINISHED PART of the BREAKWATER.

High Water Spring Tides.
 D^r D^r New D^r
 Lev D^r D^r
 D^r D^r Spring D^r

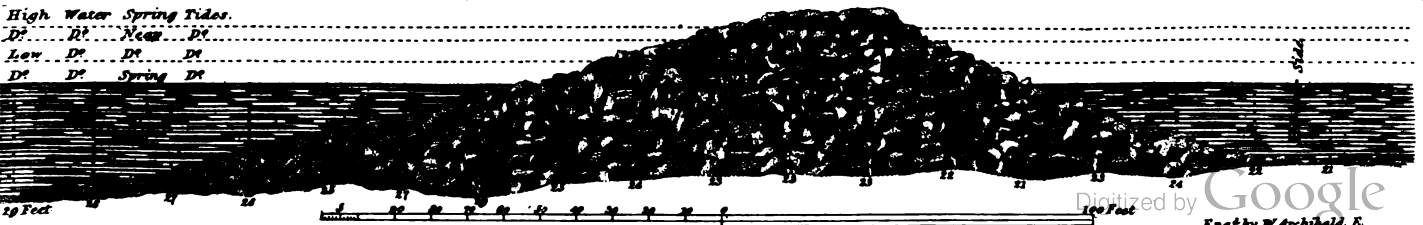

Fig. 1.

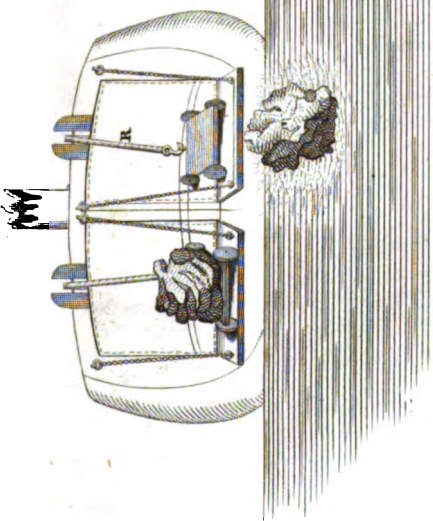
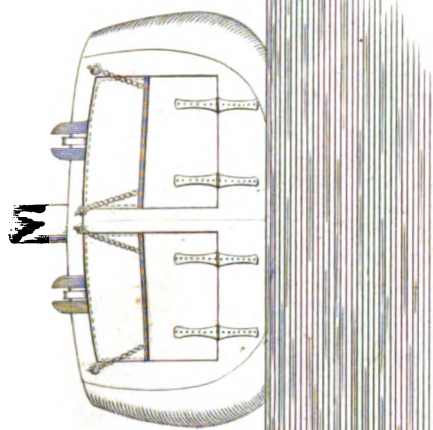

Fig. 2.



SECTION & STEER VIEW OF STOVE YEMERIA.

Scale
 1 2 3 4 5 6 7 8 9 10 11 12 13 14 15 16 17 18 19 20 Feet

Fig. 3.

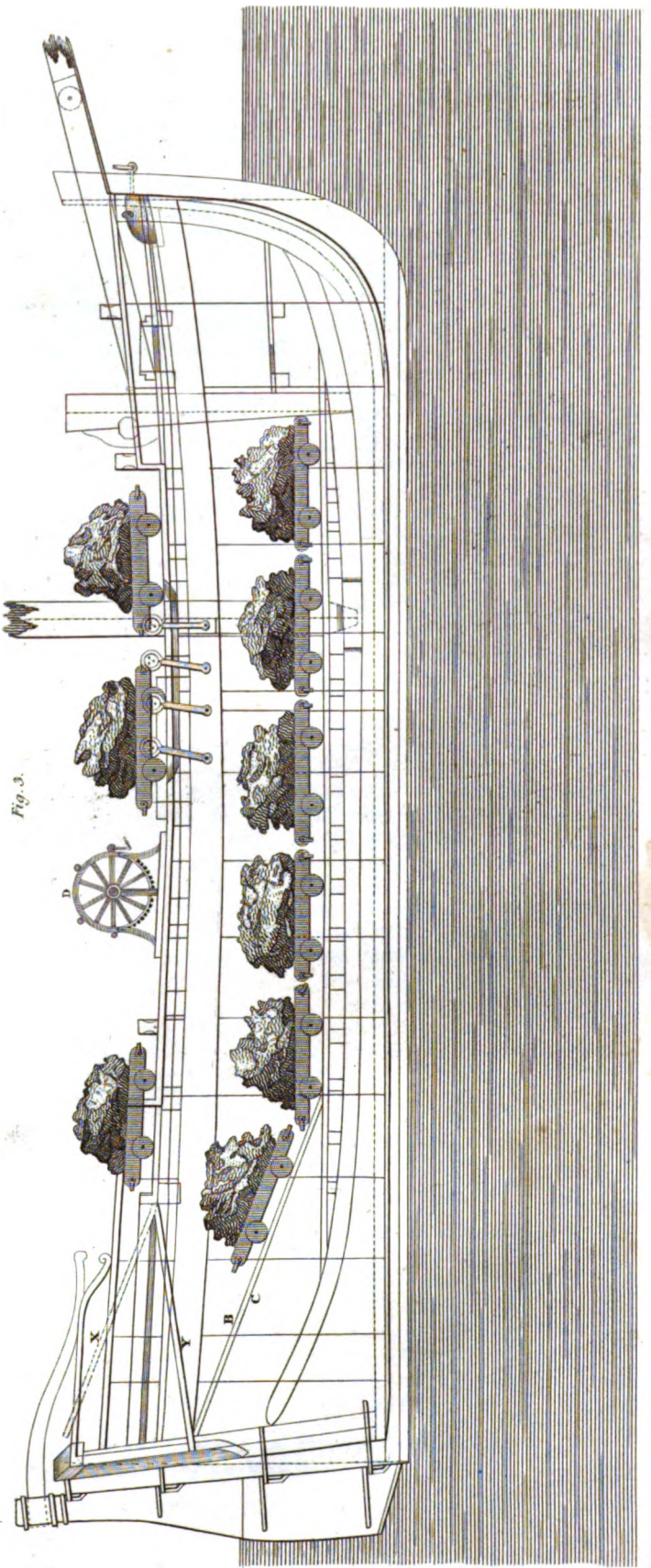

Engd by W. Probsthals, Esq.

BRECONSHIRE, or **BRECKNOCKSHIRE**, in South Wales, is divided from Radnorshire by the river Wye; its other boundaries are artificial. Its length is 29 miles, the breadth of its southern basis 34, and its circumference rather more than 100. It contains nearly 500,000 acres of land, not one-half of which are either in a state of cultivation, or adapted to it. Its form is irregularly triangular, narrowing towards the northern extremity. It is divided into six hundreds; and contains the county town, Brecon, and three market-towns besides, Crickhowel, Biulth, and Hay. There are in it one hundred and eleven parishes, and places paying parochial rates, according to the last returns to Parliament respecting these rates.

Breconshire is one of the most mountainous counties in Wales; and the Van, or Brecknock Beacon, is one of the loftiest mountains. Ridges of hills which form the separation of this from most of the adjacent counties, shelter it in such a manner as to render it temperate. It appears from observations made in the year 1802, with a rain gauge, that 26½ inches of rain fell at Brecon. There is a considerable variation, not only in the surface of the country, but also in the nature of the strata. In the hundred of Biulth, the soil is remarkably argillaceous, and the water does not sink sufficiently deep; in the Vale of Usk, on the contrary, it is too porous to retain the necessary moisture. In general, the soil of the vales consists of a light loam, lying on a deep bed of gravel; the soil of the hills, for the most part, is argillaceous. The principal river, next to the boundary one of the Wye, is the Uske, which, taking its rise from the black mountain, in the western side of the county, on the border of Caermarthenshire, flows across it, through a fine valley, to the south eastern angle, passing the town of Brecon. A little to the east of the town of Brecon is a considerable lake, well stored with fish, out of which a rivulet runs to the Wye. The Brecon Canal unites with the Monmouth Canal eight miles and a half from Newport, and one mile from Pontypool; it crosses the river Avon, is carried through a tunnel 220 yards in length, passes the town of Abergavenny towards the river Uske, and proceeds parallel with that river to Brecon, being 33 miles in length, with 68 feet rise to Brecon. From the fall of this canal from Brecon to the Bristol Channel, it appears, that Brecon is 411 feet 8 inches above the level of the sea.

The agriculture of this county is superior to that of most of the other counties of Wales, and appears to have begun to improve about the middle of the last century, as the Breconshire Agricultural Society was instituted in 1775, being one of the first associations of the kind in the Island. The mode of culture on the good soils is conducted in the best manner; but where the land is naturally poor, the tillage is very bad. In the Vale of Uske, the Norfolk rotation is followed with skill and success; and tolerably abundant crops of barley, clover, wheat, and turnips are obtained. The Highland farmers, in general, are too poor to attempt any material improvements. In the vales the farms seldom exceed 150 or 200 acres; the rents are high; in the neighbourhood of Glazbury and Hay, nearly 40s. the cyfair,

which is about one-third less than the statute acre; the poorest grounds do not let for more than four or five shillings the cyfair.

The principal exports of the county are wool, butter, and cheese; of the former, a considerable quantity is spun and knit into stockings in the hundred of Biulth, and in different parts of the Highlands; the stockings are bought by hosiers, and carried to the English market. Some sheep, a few horned cattle, and a considerable number of swine, are frequently driven to Worcester, London, Bristol, &c. The cattle and horses are small, but the former have been much improved by intermixing the Glamorganshire and Herefordshire breeds; and the latter by the introduction of the Suffolk Punch sort. A considerable number of otters frequent the rivers, the furs of which form another branch of the exports of this county.

The principal manufactures are flannel, linsey-woolsey, and other coarse cloths. These manufactures are not so flourishing as they were formerly; as, from the latter end of the sixteenth, to the beginning of the eighteenth century, considerable fortunes were acquired in Brecon and its vicinity, by the manufacture of woollen cloths. At present, the workmen confine themselves, almost entirely, to weaving what is spun by private families, into what is called *hannergate*, raw cloth. Latterly, several forges and iron founderies have been established near the borders of Glamorganshire, which abound with coal and iron-ore; and these have succeeded extremely well. The profits of the mines for the year ending 5th April 1813, according to the returns under the Property Act, were L. 2254; and of iron works L. 1006.

The poor and other parochial rates of this county, in the year ending Easter 1803, amounted to the sum of L. 12,200, 7s. 8½d. In the year ending the 25th of March 1815, there was paid in parochial rates the sum of L. 20,307, 3s. 10d.

In the year 1801, the population amounted to 31,633 inhabitants; of whom 14,346 were employed in agriculture, and 4204 in various trades and manufactures.

In 1811 there were		
Inhabited houses	- - -	7555
Families inhabiting them	- - -	7919
Houses building	- - -	97
Uninhabited houses	- - -	354
Families employed in agriculture	- - -	4667
Do. in trade, &c.	- - -	2239
Do. not comprehended in the preceding classes	- - -	1013
Males	- - -	18,507
Females	- - -	19,228
Total population	- - -	37,735
Total population in 1801	- - -	31,633
Increase	- - -	6102

See Jones's *History of Breconshire*.—Malkin's *South Wales*.—*Agricultural Report of South Wales*. (c.)

BREWING.

Brewing. As this important art has been, in a great measure, overlooked in the *Encyclopædia Britannica*, and as nothing like a satisfactory account of it is to be found in any book on the subject, which we have seen, we consider it necessary for us to lay down the principles on which it depends, somewhat in detail. We shall, therefore, divide this article into five chapters. In the first, we shall take as short a view as possible of the History of the art; in the second, we shall give an account of the different kinds of Grain employed in Brewing; in the third, we shall treat of the process of Malting; in the fourth of Brewing; and in the fifth, we shall give an account of the nature and properties of the different kinds of ale and beer manufactured by the brewer. The *Explanation of the Plates* will contain a description of the vessels used in a London porter brewery.

CHAP. I.

HISTORY OF BREWING.

No notice is taken of beer or ale in the books of Moses, from which it is probable that they were unknown till after the death of this legislator. All the ancient Greek writers agree in assigning the honour of the discovery of beer to the Egyptians, whose country, being annually inundated by the Nile, was not adapted for the cultivation of vines. Herodotus, who wrote about 450 years before the commencement of the Christian era, informs us, that the Egyptians made their wine from barley, because they had no vines. 'Οτι οὐδ' ἐκ κριθῶν πικρῶτατον ἀναχρηστικῶς ἢ γὰρ σφί τισι ἐν τῇ χώρῃ ἀμπελων Herodoti, Lib. ii. c. 78. Pliny says that this liquid in Ægypt was called *zythum* (*Plini Hist. Nat. Lib. xxii. c. 25*). The same name was given to it by the inhabitants of Galatia, who, according to Diodorus Siculus, were unable to cultivate grapes on account of the coldness of their climate. Beer was distinguished among the Greeks by a variety of names. It was called *κριθῶν* (barley wine) from its vinous properties, and from the material employed in its formation. In Sophocles, and probably in other Greek writers, it is distinguished by the name of *βύβρον*. Dioscorides describes two kinds of beer, to one of which he gives the name of *ζυθῶν* and to the other *κουργῶν*; but he gives us no description of either sufficient to enable us to distinguish them from each other. (*Dioscorides, Lib. ii. c. 79 and 80.*) Both, he informs us, were made from barley, and similar liquids were manufactured in Spain and Britain from wheat.

From Tacitus we learn, that, in his time, beer was the common drink of the Germans; and from his imperfect description of the process which they followed, it is not unlikely, or rather there can be no doubt, that they were acquainted with the method of converting barley into malt. "Potui humor ex hordeo aut frumento in quondam similitudinem vini

Brewing. corruptus." (*De Moribus German, c. 23.*) Pliny gives us some details respecting beer, though they are by no means satisfactory. He distinguishes it by the name of *cerevisia* or *cervisia*, the appellation by which it is always known in modern Latin books.

This liquid does not appear to have come into general use in Greece or Italy; but in Germany and Britain, and some other countries, it appears to have been the common drink of the inhabitants, at least as early as the time of Tacitus, and probably long before. It has continued in these countries ever since, and great quantities of beer are still manufactured in Germany, the Low Countries, and in Britain.

The first treatise published on the subject, as far as we know, was by Basil Valentine. This treatise, according to Boerhaave (for we ourselves have never had an opportunity of seeing it), is both accurate and elegant. In the year 1585, Thaddæus Hagecius ab Hayck, a Bohemian writer, published a treatise entitled *De Cervisia ejusque conficiendi ratione, natura, viribus et facultatibus*. This little treatise, consisting only of 50 pages, is written with great simplicity and perspicuity, and gives as accurate a description of the whole process of brewing as any treatise on the subject which we have seen. In the early part of the eighteenth century, Mr Combrune, who, we believe, was a practical London brewer, published a book entitled *The Theory and Practice of Brewing*. This book has gone through many editions, and we believe is still reckoned the standard book on the subject. But the attempts made in it to give a rational theory of brewing are far from satisfactory. Nor can any stress be laid upon the experiments which it contains on the colour of malt, according to the temperature at which it is dried. The fact is, that malt may be rendered brown, or even black, by exposure to a very low heat; while it may be exposed to a very considerable temperature without losing its colour. The writer of this article has seen malt exposed on the kiln to a heat of 175° without losing its colour, or without losing the power of vegetating when put into the ground; and he has reason to believe that these properties would have remained unaltered had the temperature been raised still higher. It is not the degree of heat applied, but the rapidity with which it is raised, that darkens the colour of malt. If the heat, at first, does not exceed 100°, and if after the malt is dried as much as it can be at that temperature, the heat be raised to 120°, kept sometime at that temperature, and then raised gradually higher,—if we continue to proceed in this manner, the temperature of the kiln may be elevated at least to 175° without in the least discolouring the malt.

In the year 1784, Mr Richardson of Hull published his *Theoretic Hints on Brewing Malt Liquors*, and his *Statistical Estimates of the Materials of Brewing, showing the Use of the Saccharometer*. These

Brewing. books are reprehensible, on account of the air of mystery thrown about the subject, and the avowal of the author, that he conceals certain parts of the processes. If a brewer conceives he knows more of his art than his neighbours, and chooses to keep his knowledge to himself, there is nothing to be said; but if he publish a book upon the subject, and yet persists in his concealment, he deserves no quarter. His book, in such a case, can be looked upon in no other light than a quack bill to advertise the goodness of his wares. Mr Richardson, however, deserves considerable praise for the *saccharometer*, which he appears to have been the first to bring under the notice of the brewer. This instrument is of material service, by making brewers acquainted with the strength of their worts, and consequently with the proportion of soluble matter which is furnished by the materials that they employ. Mr Richardson's *saccharometer*, indeed, was not accurate, because it was founded on a wrong principle. The method which he took was to determine the weight of a barrel of pure water. The liquid being then converted into wort, a barrel of it was weighed again, and the increase of weight was considered as the matter which the water held in solution. Mr Richardson did not seem to be aware that, when water dissolves the sweet portion of malt, its bulk is altered. Therefore, the specific gravity of it does not indicate the quantity of solid matter which it holds in solution. A set of experiments made on purpose, by dissolving determinate weights of the solid extract of malt, in given quantities of water, is necessary to determine the point. The same objection applies to the *saccharometer* of Dring and Fage, and to various others in common use. That of Dica is nearly correct, having been constructed upon proper principles. But perhaps the best is one constructed about twelve years ago by Dr Thomson, and used by the Excise officers in Scotland. It indicates the specific gravity of the wort; from which, by means of a sliding rule which accompanies the instrument, the weight of saccharine matter contained in it is at once determined.

One of the latest books on the subject which we have seen is entitled *Practical Treatise on Brewing and Distilling*. This book was published in 4to, in the year 1805. The author, whose name is Shannon, appears to have some practical knowledge of brewing; but he must have been quite illiterate, as he was totally unable to write either grammar or common sense. The book is a tissue of absurdities from beginning to end; and the impracticability of his proposed improvements is surpassed only by the absurdity of his theory, which consists of scraps and sentences, taken out of chemical books, and tacked together, so as to have no meaning whatever.

CHAP. II.

OF THE KIND OF GRAIN USED BY BREWERS.

Every kind of grain, with perhaps hardly an exception, may be employed for the purposes of the brewer. In America, it is not uncommon to make beer with

Brewing. the seeds of Indian corn or *Zea maia*. In order to convert it into malt, it is found necessary to bury it for some time under the ground, and when germination has made sufficient progress, it is dug up and kiln-dried. (See *Philosophical Transactions*, XII. 1065.) Mr Mungo Park informs us, that, in Africa, the Negroes make beer from the seeds of the *Holcus spicatus*, and the process employed, as he describes it, seems to differ but little from the one followed in this country. (See *Park's Travels*, p. 63, 8vo edition.) Dioscorides assures us, that, in Spain and Britain, wheat was employed for the manufacture of beer. And the writer of this article has been informed by a gentleman in the service of the East India Company, that he has made beer from wheat at Madras. We have ourselves seen oats employed for the same purpose in Great Britain; and in Germany and the North of Europe, we believe that it is not uncommon to apply rye to the same purpose. But the material which answers this purpose best, and which is almost solely used for this purpose in Great Britain, and we believe in every part of Europe where beer is manufactured, is barley.

Barley is the seed of the *Hordeum vulgare*, a plant Species of Barley. which has been cultivated from time immemorial, chiefly for the manufacture of beer. There are two species of *hordeum* under cultivation in Britain; 1. The *Hordeum vulgare*, or barley in which the seeds are disposed in two rows on the spike. This is the species usually cultivated in England and in the southern parts of Scotland. 2. The *Hordeum hexastichon*, called in the south of Scotland *bear*, and in Aberdeenshire *big*. In this species, the grains are disposed in two rows as in the other; but three seeds spring from the same point, so that the head of big appears to have the seeds disposed in six rows. Big is a much more hardy plant than barley, and ripens more rapidly. Hence it thrives better than barley in cold and high situations. On this account, it is sown in preference in the Highlands and northern parts of Scotland, where the climate is colder than more to the south. We have been assured, that there is a third species of *hordeum* cultivated in Scotland, in which the seeds in the spike are arranged in four rows. To this the term *bear* is exclusively confined by some. We have not ourselves had an opportunity of seeing this species, nor do we find it noticed by botanists. The trivial name *tetrastichon* might be applied to it.

The grains of barley are much larger than those of big, and the cuticle which covers them is thinner. Indeed, the thickness of the skin of barley itself varies according to the heat of the climate in which it is cultivated, being always the thinner the warmer the climate. Thus it will be found that the cuticle of Norfolk barley is thinner than that of Berwickshire or East Lothian barley. And if Norfolk barley be sown in Scotland for several successive years, its cuticle is found to become thicker.

The specific gravity of barley is rather greater than that of big. The specific gravity of barley, tried in more than 100 different specimens, was found by us to vary from 1.233 to 1.250, and that of big from 1.265 to 1.227. The average weight of a Win- Its Specific Gravity.

Brewing. chester bushel of barley, was found to be 50.7 lbs. avoirdupois, and the average weight of a bushel of big 46.383 lbs. The heaviest barley tried, weighed 32.265 lbs. per bushel, and the heaviest big 48.586 lbs. This big grew in Perthshire, and the season was peculiarly favourable. It was not absolutely free from a mixture of barley, as was ascertained by sowing a quantity of it; but the proportion of barley was very small. The average weight of a grain of barley is 0.6688 grain, or very nearly two-thirds of a grain; the average weight of a grain of big is 0.5613 grain. The average length of a grain of barley, from many thousand measurements, is 0.345 inch, while that of a grain of big is 0.3245 inch. So that the average of both would give us very nearly the third of an inch, which it ought to do, according to the origin of our measures, as commonly stated. The average breadth of a grain of barley is 0.145 inch, while the average breadth of a grain of big is 0.136 inch. The average thickness of a grain of barley is 0.1125 inch, while the average thickness of a grain of big is 0.1055 inch. Thus we perceive that the grain of big is smaller than the grain of barley in all its dimensions.

Weight of the Husk. To determine the relative weight of the skins of barley and big, we made choice of three parcels of grain, all excellent in their kinds, namely, Norfolk barley, Haddington barley, and Lanark big. The weights of the whole grain, and of the cuticles of each of these, was as follows:

	Weight of a corn in grains.	Weight of cuticle in grains.
Norfolk barley,	0.6809	0.110 or $\frac{1}{9}$
Haddington barley,	0.7120	0.123 or $\frac{1}{8}$
Lanark big,	0.5408	0.125 or $\frac{1}{8}$

From this we see, that there is little difference between the weight of the skin of Norfolk and Haddington barley, but a very considerable one between Haddington barley and Lanark big. Hence it would seem that this difference is not owing to the climate in which the barley vegetates, but rather to a difference in the nature of the two species.

Bulk. The bulks of these two species of grain to each other, is as follows:

Barley,	0.00217 cubic inch.
Big,	0.001777 cubic inch.

These quantities represent the average bulk of a corn of each kind. Thus it appears that a grain of barley is rather more than $\frac{1}{4}$ th part larger than a grain of big.

Finally, from a comparison of many thousand corns of each species with each other, it appears that the inequality between the size of different grains of big, is greater than between different grains of barley. Indeed, if we examine an ear of big, when nearly ripe, we shall perceive that the corns towards the bottom of the ear are smaller than those towards the summit and about the middle of the ear. Several of these bottom grains are usually abortive, or consist only of skin, but this is not always the case. In an ear of barley, on the contrary,

Brewing. we shall find almost all the grains nearly of a size; though, in some cases, the grain constituting the upper termination of the spike is rather smaller than the rest.

These circumstances may strike the reader as too minute and trifling to be stated in such detail; but we shall find afterwards, that they will furnish us with an explanation of some anomalous circumstances that occur when these two species of *hordeum* are converted into malt. The value of barley (or its produce in alcohol) is rather improved, while big, on the contrary, is deteriorated by malting it, at least 20 per cent.

The constituents of the kernel of barley and big, **Constituents** as far as we are able to ascertain at present, are the **constituents** same. Barley has been subjected to an elaborate chemical analysis by Einhoff, who obtained from 3840 parts of barley-corns the following constituents:

Volatile matter,	-	430
Husk or cuticle,	-	720
Meal,	-	2690
		<hr/>
		3840

From the same quantity of barley-meal, he obtained,

Volatile matter,	-	-	360
Albumen,	-	-	44
Saccharine matter,	-	-	200
Mucilage,	-	-	176
Phosphate of lime with mucilage,	-	-	9
Gluten,	-	-	135
Husk, with some gluten and starch,	-	-	260
Starch, not quite free from gluten,	-	-	2580
Loss,	-	-	76
			<hr/>
			3840

The writer of this article has likewise extracted from barley, by means of alcohol, a small quantity of an oily matter, which has an asparagus green colour, and does not burn with the same readiness as an oil. It has very much the appearance of olive oil coagulated, but its consistence is less, and its colour is darker. It has little smell, and its taste resembles the flavour of spirits from raw grain. We have likewise found in big a quantity of nitrate of soda. Hence, it is likely, that this salt exists as a common constituent of barley. We obtained it by steeping big in water for two days, concentrating the liquid, and setting it aside in a dry place. Many rhomboidal crystals of nitrate of soda gradually make their appearance as the liquid evaporates.

We shall terminate this chapter by a TABLE, exhibiting the most remarkable properties of a considerable number of specimens of British barley and big, as determined by the writer of this article. The different specimens are distinguished by the name of the county in which they grew. By the *bushel* in the table is meant the Winchester bushel of 2150.42 cubic inches.

Brewing.

BREWING.

Brewing.

TABLE OF PROPERTIES.

GRAIN.	WEIGHT		Specific Gravity	SIZE		SHAPE			EQUALITY OF SIZE											
	In lbs. Averdupois.	Per Bu. or Per Bbl.		Average Weight of a Corn in Grains Troy.	Average Bulk of a Corn in Cubic Inches.	Average Length in Inches.	Average Breadth in Inches.	Average Thickness in Inches.	Weight of a Corn in Grains.			Length in Inches.			Breadth in Inches.			Thickness in Inches.		
									Greatest.	Least.	Differ. av.	Greatest.	Least.	Differ. av.	Greatest.	Least.	Differ. av.	Greatest.	Least.	Differ. av.
1st Norfolk	50.375	302.250	1.290	0.00210	0.346	0.145	0.112	0.6954	0.6647	0.0307	0.387	0.318	0.069	0.166	0.128	0.038	0.125	0.092	0.033	
1st Kent	49.877	299.262	1.250	0.00209	0.343	0.142	0.108	0.6775	0.6410	0.0365	0.369	0.287	0.086	0.160	0.116	0.044	0.125	0.087	0.038	
1st Suffolk	50.683	304.098	1.290	0.00216	0.344	0.145	0.110	0.6960	0.6940	0.0470	0.384	0.300	0.084	0.159	0.126	0.033	0.120	0.096	0.024	
2d Norfolk	50.570	303.420	1.272	0.00216	0.344	0.145	0.112				0.553	0.301	0.052	0.154	0.119	0.050	0.119	0.100	0.016	
2d Kent	50.062	300.372	1.290	0.00216	0.344	0.143	0.108	0.6740	0.6250	0.0490	0.362	0.328	0.034	0.159	0.118	0.041	0.121	0.083	0.038	
2d Suffolk	49.250	295.500	1.307	0.00198	0.345	0.141	0.107	0.6090	0.5890	0.0190	0.369	0.292	0.077	0.155	0.111	0.044	0.125	0.089	0.036	
3d Norfolk	51.937	311.622	1.290	0.00198	0.345	0.141	0.107													
3d Norfolk	47.683	286.098	1.291	0.00198	0.345	0.139	0.103													
3d Essex	47.683	286.098	1.291	0.00198	0.345	0.139	0.103													
Average	50.054	300.327	1.28	0.00208	0.343	0.143	0.108	0.6689	0.6415	0.0384	0.370	0.304	0.067	0.160	0.121	0.038	0.123	0.092	0.030	
1st Haddington	52.190	313.140	1.333	0.00211	0.336	0.154	0.120	0.7342	0.6954	0.0388	0.368	0.286	0.082	0.171	0.107	0.064	0.131	0.089	0.042	
1st Edinburgh	52.164	312.984	1.290	0.00217	0.335	0.149	0.116	0.7204	0.6906	0.0398	0.369	0.300	0.069	0.162	0.129	0.033	0.127	0.101	0.026	
1st Berwick	52.062	312.372	1.307	0.00217	0.335	0.143	0.111				0.361	0.290	0.071	0.160	0.124	0.036	0.126	0.087	0.035	
1st Linlithgow	51.062	306.372	1.324	0.00228	0.373	0.150	0.117				0.426	0.326	0.098	0.164	0.130	0.034	0.130	0.094	0.036	
2d Haddington	52.265	313.590	1.333	0.00204	0.346	0.145	0.111	0.7080	0.6700	0.0320	0.380	0.288	0.092	0.170	0.111	0.059	0.132	0.072	0.060	
3d Haddington	48.987	293.922	1.250	0.00208	0.341	0.144	0.108	0.6790	0.6260	0.0530	0.370	0.308	0.062	0.159	0.117	0.042	0.121	0.085	0.036	
3d Linlithgow	46.375	278.250	1.333	0.00208	0.347	0.139	0.106							0.164	0.120	0.044	0.130	0.089	0.041	
Average	50.729	304.375	1.310	0.00213	0.346	0.146	0.112	0.7089	0.6705	0.0384	0.379	0.300	0.079	0.164	0.119	0.044	0.128	0.088	0.039	
Big.																				
1st Lanark	48.560	291.360	1.250	0.00170	0.328	0.133	0.103	0.5508	0.5341	0.0167	0.378	0.278	0.100	0.152	0.116	0.036	0.118	0.087	0.031	
1st Perth	48.586	291.516	1.227	0.00189	0.324	0.136	0.105	0.6142	0.5668	0.0478	0.379	0.274	0.105	0.167	0.108	0.059	0.130	0.086	0.044	
1st Dumfries	47.500	285.000	1.246	0.00177	0.322	0.136	0.108	0.5857	0.5268	0.0607	0.370	0.267	0.103	0.160	0.114	0.046	0.122	0.088	0.034	
2d Kirkcudbright	47.031	282.186	1.265	0.00174	0.324	0.139	0.106	0.5720	0.5520	0.0200	0.356	0.280	0.076	0.155	0.110	0.045	0.119	0.087	0.032	
Average	47.919	287.515	1.247	0.00177	0.324	0.136	0.105	0.5811	0.5449	0.0363	0.370	0.274	0.096	0.158	0.112	0.046	0.122	0.087	0.035	

CHAP. III.

OF MALTING.

It is always customary to convert barley into malt before employing it in the manufacture of ale. Not that this conversion is absolutely necessary, but that it adds considerable facility to the different processes of the brewer. The writer of this article has several times tried the experiment of making ale from unmalted barley, and found it perfectly practicable. Several precautions, however, are necessary in order to succeed. The water let upon the ground barley in the mash-tun must be considerably below the boiling temperature. For barley meal is much more apt to set than malt, that is, to form a stiff paste, from which no wort will separate. The addition of a portion of the chaff of oats serves very much to prevent this setting of the goods, and facilitates considerably the separation of the wort. Care must likewise be taken to prevent the heat from escaping during the mashing, and the mashing must be continued longer than usual. For it is during the mashing that the starch of the barley is converted into a saccharine matter. This change seems to be owing merely to the chemical combination of a portion of water with the starch of the barley; just as happens when common starch is converted into sugar, by boiling it with very dilute sulphuric acid, or any other acid. This method of brewing from raw grain answers admirably for small beer. Some years ago it was practised to a considerable extent by several brewers of small beer in Edinburgh, and their beer was considered as greatly preferable to small beer brewed in the usual manner. The practice was stopped by a decision of the Court of Exchequer,—a decision, which, in our opinion, proceeded upon arbitrary grounds, and which was at all events detrimental to the public; for surely it is highly impolitic to prevent ameliorations in the manufactures, in order to guard against any deficiency in the produce of the taxes. A wise government would have permitted the improvement, and would have levied the malt-tax in a different manner. In our trials the raw barley did not answer so well for making strong ale as for small beer. The ale was perfectly transparent, and we kept it for several years without its running into acidity. But it had a peculiar flavour, by no means agreeable. Probably a little practice might have enabled us to get rid of this flavour, in which case, raw grain would answer, in every respect, as well for brewing as malt does.

A duty was first charged upon malt during the troubles of Charles I.'s reign. But it continued very moderate till the war with Bonaparte began in 1802. It was then raised to the following sums *per bushel*:

	L.	s.	d.	
English malt	0	4	4	or 100
Malt of Scotch barley	0	3	8½	or 84.856
Malt of Scotch big	0	3	0½	or 69.478

But two shillings of this tax were to continue only

till the end of the war, and for six months after its conclusion. In consequence of this very heavy tax, several regulations were imposed upon the maltster, with a view to facilitate the levying the duty, and to prevent him from defrauding the revenue. The most important of these are the two following: 1. The barley must remain in the cistern in which it is steeped with water for a period not less than 40 hours. When the malt is spread upon the floor, the maltster is not at liberty to sprinkle any water upon it, or to moisten the floor. We shall now describe the process of malting, as it is practised by the best informed malt-makers in Great Britain.

Malting consists of four processes, which follow each other in regular order; namely, *steeping, couching, flooring, and kiln-drying*.

1. The steep is a square cistern sunk at one end of the malt barn, lined with stone, and of a sufficient size to hold the whole barley that is to be malted at a time. The barley is put into this cistern, with the requisite quantity of pure water to cover it. It is laid as evenly as possible upon the floor of the cistern. Here it must remain at least 40 hours; but in Scotland, especially when the weather is cold, it is customary to allow it to remain much longer. We have seen barley steeped in Edinburgh for 112 hours by one maltster, and by another usually 98 or 92 hours. It is the common practice to introduce the water into the cistern before the barley, and it is usually once drawn off, and new water added during the steeping.

Three changes take place on the barley while in the steep. 1. It imbibes moisture, and increases in bulk. 2. Some carbonic acid gas is evolved, most of which remains dissolved in the steep-water. 3. A portion of the husk or skin of the barley is dissolved, in consequence of which the steep-water acquires a yellow colour, and contracts a peculiar smell, not unlike that of moist straw.

The quantity of moisture imbibed by the barley varies according to the goodness of the barley, and the length of time during which it is allowed to remain in the steep. But the general average may be stated at 0.47; or 100 lbs. of barley, steeped the usual time, weigh, when newly taken out of the steep and dried, 147 lbs. English barley acquires more weight than Scotch barley, while Scotch barley acquires greater weight than big. But big cannot bear to be steeped for so long a time as barley. The swell of the grain in the steep obviously depends upon the quantity of water absorbed; but it is not so great as that absorption, scarcely ever exceeding one-fifth of the original bulk of the barley, while the increase of weight amounts to nearly one-half of that of the original weight of the grain. The result of a good many trials by the writer of this article, gives the bulk of 100 measures of different kinds of barley, after steeping, as follows:

English barley	-	124	measures
Scotch barley	-	121.1	
Scotch big	-	118.	

The greatest swell observed was from 100 to 183, which took place in barley from the County of Suf-

Brewing. folk; the smallest was from 100 to 109, which took place in Perth big.

While the malt is in the steep cistern, it is repeatedly gauged by the Exciseman, and the duty on the malt is levied by what is called the best gauge, or that which gives the greatest bulk of grain. It is in his power likewise to determine the quantity of malt in the subsequent processes, and if any of them exceeds the best gauge in the cistern, to levy the duty by it. But these subsequent gauges are not susceptible of the same precision as the gauges in the cistern, when the grain is surrounded on all sides by perpendicular walls.

Carbonic Acid evolved. That carbonic acid is evolved during the steeping of grain, is obvious from the most simple experiments. If the steep-water be mixed with lime-water, the whole becomes milky, and carbonate of lime is deposited. If the steep-water be agitated, it froths on the surface like ale. If it be heated, it gives out carbonic acid gas, which may be collected over mercury. But we never were able to observe bubbles of gas extricate themselves from the grain during the steep, except once or twice during warm weather, when the steep-water was allowed to remain rather too long without being changed. In these cases, something like a commencement of fermentation, or perhaps of putrefaction, appeared to take place. But, in general, there is reason to believe, that nearly all the carbonic acid evolved in the steep remains in solution in the water, or at least is extricated from the water in an imperceptible manner. From the observations of Saussure, it seems probable, that the formation of carbonic acid in the steep is owing to the oxygen gas held in solution by the steep-water.

Matter dissolved by the Steep-water. The steep-water gradually acquires a yellow colour, and the peculiar smell and taste of water in which straw has been steeped. At the same time, the barley becomes whiter; showing clearly that the water has absorbed a portion of colouring matter which existed in the husk or skin of the grain. The average quantity of matter dissolved by the water amounts to about $\frac{1}{10}$ th of the weight of the barley. The steep-water becomes much deeper coloured when big is steeped in it than it does with barley; because big is darker coloured, and its husk is thicker, and contains more colouring matter. The matter of big taken up by the steep-water amounts to about $\frac{1}{10}$ th of the weight of the whole grain. When this steep-water is evaporated, it leaves a matter of a yellow colour and disagreeable bitter taste, which deliquesces in a moist atmosphere. The only salt which it contains in any notable quantity is nitrate of soda.

Thus the only notable alterations which the kernel of barley undergoes in the steep are the absorption of water, and the resulting increase of bulk. The matter taken up by the water seems to proceed only from the skin, and the evolution of carbonic acid may, perhaps, be owing to some commencement of alteration which this dissolved matter experiences. It can scarcely be ascribed to any change going on within the kernel itself.

The Couch. 2. When the barley is judged by the maltster to have remained long enough in the steep, which is

Brewing. the case when its two ends can be easily squeezed together between the finger and the thumb, the water is let off, and the grain allowed to drain. It is then thrown out of the cistern upon the malt floor, where it is formed into as regular a rectangular heap as possible, which is called the *couch*. While in this position, it is gauged by the exciseman; and, if it measure more than it did in the steep, he is at liberty to charge the duty upon the quantity to which the grain now amounts. But, as the barley in the couch cannot be rendered perfectly regular, it requires a good deal of skill, and considerable attention, to gauge it with tolerable accuracy. On that account, the duty, we believe, is seldom levied from the couch gauge. The grain is allowed to remain in the couch without any alteration for about 26 hours.

3. If we plunge a thermometer into the grain, and **Sweating.** observe it from time to time, we shall find that the barley continues for some hours without acquiring any perceptible increase of heat. During this period, the moisture on the surface of the corns gradually exhales or is absorbed, so that they do not perceptibly moisten the hand. But at last the thermometer begins to rise, and continues to do so gradually, till the temperature of the grain is about ten degrees higher than that of the surrounding atmosphere. This happens usually in about 96 hours after it has been thrown out of the steep. It now exhales an agreeable odour, which has some resemblance to that of apples. If we thrust our hand into the heap, we shall find it to feel warm, while, at the same time, it has become so moist as to wet the hand. The appearance of this moisture is called *sweating* by the maltsters, and it constitutes a remarkable period in the process of malting. We have reason to believe that a little alcohol is at this period exhaled by the grain.

If we examine the grains in the inside of the heap **Sprouting of the Roots.** at the time of sweating, we shall perceive the roots beginning to make their appearance at the bottom of each seed. At first they have the appearance of a white prominence, which soon divides itself into three rootlets. In big, the number of rootlets seldom exceed three; but in barley they frequently amount to five or six. These rootlets increase in length with great rapidity, unless their growth be checked by artificial means. And the principal art of the maltster is directed to keep them short till the grain is sufficiently malted. The writer of this article has seen them increase in length nearly to two inches in the course of a single night; and when he purposely favoured the growth, in order to ascertain the effect upon the malt, he has seen them get to the length of three inches or more. In such cases, the heat of the grain rose very rapidly, and on one occasion was little inferior to 80°. Indeed, it is probable that, if not checked, the temperature would rise sufficiently high to char the grain, if not to set it on fire.

The too great growth of the roots, and the too high elevation of temperature, is prevented by spreading the grain thinner upon the floor, and carefully turning it over several times a day. At first the depth is about 16 inches; but this depth is diminished a little at every turning, till at last it is re-

Brewing. duced to three or four inches. The number of turnings is regulated by the temperature of the malt; but they are seldom fewer than two each day. In Scotland, the temperature of the grain is kept as nearly as possible at 55°; but in England we have generally found the temperature of the grain on the malt floor about 62°. It has been generally supposed that the Hertfordshire method of making malt is the best; but, after a very careful comparison of the two methods, we were unable to perceive any superiority whatever in the English mode.

Acrospire. About a day after the sprouting of the roots, the rudiments of the future stem begins to make its appearance. This substance is called by the maltsters the *acrospire*. It rises from the same extremity of the seed with the root, and, advancing within the husk or skin, would at last (if the process were continued long enough) issue from the other extremity in the form of a green leaf; but the process of malting is stopped before the *acrospire* has made such progress.

While the grain is on the malt floor, it has been ascertained that it absorbs oxygen gas, and emits carbonic acid gas. But to what amount these absorptions and emissions take place, has not been ascertained. They are certainly small; for the average loss which the grain sustains when on the malt floor is only 3 per cent., a considerable portion of which must be ascribed to roots broken off, and grains of barley bruised during the turning. As the *acrospire* shoots along the grain, the appearance of the kernel or mealy part of the corn undergoes a considerable change. The glutinous and mucilaginous matter in a great measure disappears, the colour becomes whiter, and the texture so loose, that it crumbles to powder between the fingers. The object of malting is to produce this change. When it is accomplished, which takes place when the *acrospire* has come nearly to the end of the seed, the process is stopped altogether.

At this period, it was formerly the custom in Scotland to pile up the whole grain into a pretty thick heap, and allow it to remain for some time. The consequence is, the evolution of a very considerable heat, while, at the same time, the malt becomes exceedingly sweet. But this plan is now laid aside, because it occasions a sensible diminution in the malt, without being of any essential service. For the very same change takes place afterwards, while the malt is in the mash-tun, without any loss whatever.

The time during which the grain continues on the malt floor varies according to circumstances. The higher the temperature at which the grain is kept, the more speedily is it converted into malt. In general, 14 days may be specified as the period which intervenes in England from throwing the barley out of the steep, till it is ready for the kiln; while in Scotland, it is seldom shorter than 18 days, and sometimes three weeks. This, no doubt, is an advantage in favour of English malting; as every thing which shortens the progress, without injuring the malt, must turn out to the advantage of the manufacturer

4. The last part of the process is to dry the malt

upon the kiln, which stops the germination, and enables the brewer to keep the malt for some time without injury. The kiln is a chamber, the floor of which usually consists of iron plates full of holes, and in the roof there is a vent to allow the escape of the heated air and vapour. Under this room is a space in which fire of charcoal or coak is lighted. The heated air which supplies this fire passes up through the holes in the iron plates, and makes its way through the malt, carrying off the moisture along with it. At first, the temperature of the malt is not higher than 90°; but it is elevated very slowly to 140°, or even higher. We believe, that in many cases, it rises at last almost as high as 212°, though we have never witnessed any such high temperature ourselves. But we have seen pale malt dried at a temperature of 175°, without any injury whatever. The great secret in drying malt properly, consists in keeping the heat very low at first, and only raising it very gradually, as the moisture is dissipated. For a high temperature, applied at first, would infallibly blacken, or even char the malt, and would certainly diminish considerably the quantity of soluble matter which it contains. We shall here insert the table drawn up by Mr Combrune, from his own experiments, of the colour of malt dried in different temperatures.

Heat.		
119°	-	White
124	-	Cream-colour
129	-	Light yellow
134	-	Amber-colour
138	-	High amber
143	-	Pale brown
148	-	Brown
152	-	High brown
157	-	Brown inclining to black
162	-	High brown speckled with black
167	-	Blackish brown with black specks
171	-	Colour of burnt coffee
176	-	Black

We have given this table, not on account of any information which it contains, but to put our readers on their guard against the false conclusions of this writer. We have taken malt dried at the temperature of 175°, put it into a garden pot filled with soil, and have seen it vegetate apparently as well as raw grain placed in the same situation. Now, this is only one degree lower than that in which Mr Combrune says malt is converted into charcoal, and it is four degrees higher than that in which his malt assumed the colour of burnt coffee. Certainly malt reduced to the colour of burnt coffee by heat, would be deprived of the power of vegetating. Mr Combrune's experiments were made by putting malt into an earthen pan, which he placed over a charcoal fire in a stove, while he kept stirring the malt the whole time of the experiment. The bulb of the thermometer was placed half-way between the upper surface of the malt and the bottom of the vessel. Now, the reader will perceive at once, that the earthen pan would be much hotter than that part of the malt where the thermometer was placed. By the constant stirring of the malt, the whole of

Brewing. it was gradually exposed to the burning action of the surface of the pan. Had the experiment been made without stirring the malt at all, and had the thermometer been placed near the surface, in that case, the changes in the colour of the malt at the surface would have indicated the temperature to which it was exposed. But in the way that Mr Combrune conducted his experiments, the temperatures which he obtained were entirely fallacious. We have not the least doubt, that the temperature of the earthen pan, towards the end of his experiment, was above 400°.

Mr Combrune's law, however, that the heat of the water in mashing ought to be regulated by the colour of the malt; namely, that the paler the malt is, the lower ought the temperature of the mashing water to be, is founded on accurate observations. The fact is, that boiling water would answer better than any other for mashing, because it would dissolve most speedily the soluble part of the malt. The only reason for not using it is, that the tendency of the malt to *set* increases with the temperature of the water. Now, the higher the colour of the malt, the less is its tendency to *set*; of course, we may use water of a higher temperature to mash with it. For the same reason, when raw grain is used, the temperature of the mashing water must be still lower than when malt is employed; because raw grain has a very great tendency to *set*.

The old malt-kilns had a bottom of hair-cloth instead of the iron plates full of holes, which constitute a more recent improvement. We have seen the thermometer in such a kiln, when the bulb touched the hair-cloth, rise as high as 186°. In general, the temperature of the malt-kiln is very carelessly regulated. We have seen malt for the very same purpose dried at a temperature which never rose higher than 136°; while a portion of the very same malt, put into another kiln, was heated as high as 186°. But such a careless mode of drying malt is reprehensible, and must be more or less injurious to the brewer. In general, the more rapidly malt is dried the more does its bulk increase. This method, accordingly, is practised by those who malt for sale, as is the case with most of the English maltsters; because malt is always sold by measure, and not by weight. The brewers would find it more for their interest to buy malt by weight than by measure. In that case, the maltsters would dry their malt at as low a temperature as possible. But this would signify very little, or rather would be advantageous to the brewer; because dried malt soon recovers the moisture lost on the kiln when kept for some time in sacks. And, when malt is dried at a low temperature, we are sure that none of it is injured by the fire. It will, therefore, go farther in the production of beer. The time of kiln-drying varies considerably, according to the quantity of malt exposed to the action of the heat. But when that quantity is not too great, we may estimate the time of kiln-drying, in general, at two days. After the fire is withdrawn, the malt is allowed to remain on the kiln till it has become nearly cold.

By the kiln-drying, the roots of the barley, or, as the maltsters call them, the *comings*, are dried up

and fall off. They are separated from the malt by **Brewing.** passing it over the surface of a kind of wire-screen, which allows the *comings* to drop through, while the wires are too near each other to permit the grains of malt to pass.

If 100 lbs. of barley malted in this manner, with **Changes** all the requisite care, be weighed just after being **produced** kiln-dried and cleaned, they will be found, on an average, to weigh 80 lbs. But if the raw grain be kiln-dried at the same temperature as the malt, it will lose 12 *per cent.* of its weight. Hence 12 *per cent.* of the loss which barley sustains in malting, must be ascribed to moisture dissipated by the kiln-drying; so that the real loss of weight which barley sustains when malted, amounts to 8 *per cent.* This loss, from a great many trials made in the large way, with all the requisite care, we conceive may be accounted for in the following manner:

Carried off by the steep-water	-	1.5
Dissipated while on the floor	-	3.0
Roots separated by cleaning	-	3.0
Waste	-	0.5
		8.0

These numbers were obtained from above thirty different maltings, conducted in four different malting-houses, with as much attention to every circumstance as was compatible with practical malting. The matter carried off by the steep-water, which amounts to about $\frac{1}{8}$ th of the weight of the whole grain, we conceive to be dissolved from the skin or husks. It may, therefore, be left out of view. The waste is owing to grains of malt crushed by the workmen while turning the malt on the floor, and afterwards dissipated or destroyed during the subsequent processes. We were not able to collect these bruised grains and weigh them; the number therefore given for them in the preceding table is hypothetical; but from a great many circumstances, which it would be too tedious to adduce here, we believe that, in our trials, $\frac{1}{20}$ th part of the whole very nearly represents the amount of the crushed grains. Thus the real loss of weight by malting (supposing nothing lost by steeping, and no grains crushed) is only 6 *per cent.* and of this loss 4 *per cent.* may be safely ascribed to the roots; so that not above 2 *per cent.* at most can be assigned to the carbon dissipated by the evolution of carbonic acid on the floor, and on the kiln. Indeed we have reason to conclude, from a good many trials, that the greatest part of this loss of 2 *per cent.* is sustained on the kiln. For, if malt dried carefully at a low temperature be afterwards kiln-dried, or exposed (as was our method) to the heat of a steam bath, it never afterwards recovers its former weight by exposure to the air. And every time this experiment is repeated, by artificially moistening and drying the same malt, a new loss of weight is sustained. The same observation was made by Saussure, who conceived that the loss was to be ascribed to the formation and dissipation of water in the barleycorn. But we have no proof that any such formation takes place. It is more probable that the loss is owing to the formation and escape of carbonic acid gas.

Big sustains a considerably greater loss of weight when malted than barley. The average loss of weight in our trials with barley was only 8 per cent., while that of big was 15 per cent., or nearly double. This we conceive is owing to the destruction of a much greater number of the corns during the process of malting big than barley. But, in all our experiments on big, that grain was manifestly oversteeped. To this, perhaps, a good deal of the difference may be ascribed. Our maltsters had not been in the habit of malting big, and therefore were not likely to do it so much justice as they did to the barley. Hence it would be improper to venture upon any general conclusions from the experiments which we made upon the malting of big.

The bulk of the malt is usually greater than that of the barley from which it was obtained. But this varies a good deal, according to the goodness of the grain, and the mode of drying the malt. In our trials, made all in the same way, 100 bushels of the different kinds of grain gave, on an average, the following results:—

English barley,	-	-	109
Scotch barley,	-	-	103
Scotch big,	-	-	100.6

The greatest quantity in bushels obtained from 100 bushels of English barley was 111½, the least 106 bushels. The greatest quantity obtained from 100 bushels of Scotch barley was 109, and the least 98 bushels. The greatest quantity obtained from 100 bushels of big was 103 bushels, the least 97 bushels. Hence it appears that, on malting English barley, there is a profit of 9 per cent., while big yields scarcely any thing more than its bulk before malting. The English maltster makes more bushels of malt than he pays duty for; but the maltster of big, on the contrary, obtains fewer.

We shall subjoin here two Tables, which exhibit in one view the result of a considerable number of trials made by the author of this article, on malting different varieties of grain. The barley is distinguished by the name of the county where it grew. To understand the first table, the reader must know that Excisemen estimate the quantity of malt by subtracting one-fifth from the best or highest gauge in the steep or couch, and charge the duty accordingly.

TABLE I.

Grain Barley.	Original bulk of Grain.	Bulk by best Gauge in Steep or Couch.	Produce in Malt.	Malt charged Duty.	Difference per cent.
ENGLISH.					
1st Qualities.					
Norfolk -	100	123.0	109.5	98.4	
Norfolk -	100	121.5	104.5	97.2	
Kent -	100	128.0	111.2	102.4	
Kent -	100	119.7	106.3	95.8	
Suffolk -	100	122.7	101.6	98.6	
Suffolk -	100	116.8	100.8	93.4	
Average	100	122.1	105.0	97.6	8

Grain Barley.	Original bulk of Grain.	Bulk by best Gauge in Steep or Couch.	Produce in Malt.	Malt charged Duty.	Difference per cent.
ENGLISH.					
2d Qualities.					
Norfolk -	100	129.6	109.2	103.7	
Norfolk -	100	122.0	103.9	97.6	
Suffolk -	100	137.9	107.6	109.5	
Kent -	100	133.2	109.2	106.5	
Kent -	100	125.6	105.3	100.4	
Average	100	129.6	107.0	104.4	2.6
3d Qualities.					
Norfolk -	100	128.2	106.4	102.5	
Norfolk -	100	127.1	104.5	101.6	
Essex -	100	134.5	106.5	107.6	
Essex -	100	126.3	105.8	101.0	
Essex -	100	128.0	102.1	102.4	
Essex -	100	120.5	97.6	96.4	
Average	100	127.4	103.4	101.9	1.9
General average					4.03
SCOTCH.					
1st Qualities.					
Berwick and Haddington					
Haddington	100	119.8	100.6	95.8	
Haddington	100	121.0	109.4	96.8	
Haddington	100	121.0	103.1	96.8	
Linlithgow	100	118.7	106.2	94.9	
Perth -	100	127.3	102.4	101.8	
Fife -	100	125.3	100.1	100.2	
Angus -	100	123.8	103.6	100.6	
Edinburgh	100	123.8	98.6	99.0	
Edinburgh	100	116.7	102.7	93.3	
Average	100	119.6	102.9	97.6	5.3
2d Qualities.					
Berwick and Haddington					
Haddington	100	119.4	100.9	95.5	
Haddington	100	125.8	103.2	100.6	
Perth -	100	114.2	96.9	91.3	
Fife -	100	119.6	94.0	95.6	
Average	100	119.7	98.7	95.7	3
3d Qualities.					
Berwick and Haddington					
Haddington	100	115.2	98.2	92.1	
Haddington	100	120.0	101.6	96.0	
Linlithgow	100	113.6	92.3	90.8	
Linlithgow	100	121.0	93.4	96.8	
Fife -	100	117.5	91.5	94.0	
Angus -	100	120.8	101.1	96.6	
Average	100	118.0	96.3	94.4	1.9
General average					3.4

Tables of Malting.

Brewing.

Brewing.

Grain Big.	Original bulk of Grain.	Bulk by best Gauge in Steep or Couch.	Produce in Malt.	Malt charged Duty.	Difference percent.
1st Qualities.					
Dumfries	100	112.0	97.6	89.6	
Dumfries	100	132.8	97.9	106.2	
Lanark -	100	121.6	103.3	96.3	
Perth -	100	120.9	102.9	95.7	
Perth -	100	120.7	99.1	95.5	
Perth -	100	112.8	97.4	89.2	
Aberdeen	100	127.3	100.7	101.8	
Aberdeen	100	125.6	99.9	100.5	
Aberdeen	100	114.5	94.1	91.6	
Aberdeen	100	124.0	98.7	99.2	
Average	100	121.2	99.1	97.0	2.1

Grain Big.	Original bulk of Grain.	Bulk by best Gauge in Steep or Couch.	Produce in Malt.	Malt charged Duty.	Difference percent.
2d Qualities.					
Kirkcudbright	100	119.5	101.2	95.6	
Ayr -	100	114.2	101.1	91.3	
Angus -	100	127.4	96.8	101.9	
Angus -	100	121.6	94.5	97.2	
Mearns -	100	121.3	96.5	97.0	
Average	100	120.8	98.1	96.6	1.5
3d Qualities.					
Kirkcudbright	100	110.6	94.5	88.4	
Aberdeen	100	123.1	105.0	98.4	
Average	100	116.8	99.7	93.4	6.3
General average					3.3

TABLE II.

BARLEY	Weight per Bushel in lbs.	Bushels Measured out.	Swimmings in Bushels.	Bushels really Steeped.	Swimmings in lbs. A-voirdupois.	Weight of Grain really Steeped in lbs.	Hours in Steep.	Swell per cent. in Steep.	Swell per cent. in Couch.	Days on Floor.	Clean Malt in Bushels.	Weight of Clean Malt per Bushel.	Apparent loss of Weight per cent.	BUSHEL ^S of MALT.		POUNDS of MALT.	
														From 100 Bushels Grain.	From 100 lbs. Grain.	From 1 Bushel Grain.	From 1 lb. Grain.
1st Quality.																	
ENGLISH.																	
Norfolk	50.375	150	1.4	148.60	43.18	7509.82	116	16	23.08	18	162.75	36.58	20.0	109.5	2.17	40.063	0.793
Norfolk	50.375	150	1.75	148.25	43.00	7513.50	93.75		21.5	16	155.00	38.40	21.2	104.5	2.06	40.152	0.788
Kent	49.750	90	1.96	88.09	56.45	4421.05	86	25	28.	12	98	34.88	23.0	111.2	2.22	38.816	0.773
Kent	49.914	90	1.75	88.25	40.50	4442.63	52	15.7	19.7	17	93.87	35.76	25	106.3	2.11	38.926	0.755
Suffolk	50.508	150	2.68	147.32	84.15	7494.00	49		23.3	13	149.75	40.56	21	101.6	2	41.227	0.810
Suffolk	50.859	72	1.28	70.72	29.44	3632.40	44		16.8	13	71.31	39.11	23.2	100.8	1.96	39.435	0.768
Average	50.297						73.4	18.9	22.06	14.8		37.55	22.2	105.6	2.09	39.736	0.781
Scotch.																	
Berwick & Haddington	53.099	114.75	1.23	113.52	23.87	6068.60	119		19.8	18	114.18	39.60	25.4	100.6	1.88	39.840	0.746
Haddington	52.190	60	0.5	59.50	13.75	3117.50	92	21		20	64.50	38.06	21	199.4	2.07	41.618	0.787
Haddington	52.190	75	0.3	74.70	11.26	3902.80	112	21	21	19	77	39.18	23	103.1	1.97	40.386	0.773
Linlithgow	51.062	66	0.56	65.44	18.34	3352.81	109	24.5	18.7	9	69.5	39.09	19	106.2	2.07	41.520	0.810
Perth	50.226	66	0.75	65.25	21.00	3293.95	57		27.3		66.86	38.18	22.49	102.4	2.03	39.191	0.775
Perth	51.539	148	1.62	146.38	40.00	7578.78	81		25.3	14	146.54	38.80	25.07	100.1	1.93	38.843	0.749
Perth	49.312	66	1.68	64.92	44.37	3210.25	80	25.8	23.8	8	66.6	36.76	24	103.6	2.07	38.074	0.763
Perth	52.164	111	1.50	109.5	41.37	5748.82	76	23	23.8	14	108	41.92	21	98.6	1.88	41.345	0.787
Perth	52.164	90	1.25	88.75	34.47	4660.29	52.5	14.8	16.7	16	91.12	40.24	22	102.7	1.95	41.319	0.787
Average	51.549						86.5	21.7	19.6	13		39.09	22.6	102.9	1.98	40.23	0.775
Bigs.																	
Dumfries	47.000	75	3.28	71.72	77.00	3448.00	73		12	13	70	36.81	23.5	97.6	2.03	35.930	0.765
Dumfries	47.726	80	2.09	77.97	59.96	3758.16	80	25.8	32.8	8	76.31	37.70	23.5	97.9	2.03	36.899	0.765
Lanark	48.562	150	2.67	147.33	79.65	7204.72	80	11	21.6	18	152.25	36.44	23	103.3	2.11	37.637	0.770
Lanark	48.585	100	2.00	98	61.84	4796.66	104	17	20.9	13	100.94	34.44	27.5	102.9	2.10	35.374	0.724
Perth	48.562	98	3.25	94.75	97.45	4661.68	73	18	20.7	13	93.86	37.57	24.5	99.1	2.01	37.237	0.757
Perth	48.562	90	3.00	87.00	81.06	4289.56	45	9.4	12.8	15	84.75	36.53	28	97.4	1.97	35.586	0.722
Aberdeen	48.226	90	2.09	87.91	55.81	4284.57	74	23	27.3	8	88.50	38.37	21	100.7	2.06	38.639	0.793
Aberdeen	48.562	150	2.68	147.32	88.19	7196.19	89		25.6	10	146.25	36.03	26.8	99.3	2.13	35.770	0.732
Aberdeen	48.312	90	2.25	87.75	57.50	4291.62	58		14.5	10	82.60	39.00	25	94.1	1.93	36.712	0.751
Aberdeen	49.172	90	2.26	87.74	60.75	4364.72	57		24		86.58	39.44	21.7	98.7	1.98	38.906	0.783
Average	48.327						73	17.3	21.2	10.8		37.23	24.4	99.1	2.03	36.868	0.756

BARLEY. 2d Quality.	Weight per Bush- el in lbs.	Bushels Measur- ed out.	Swim- ming in Bush- els.	Bushels really Steeped.	Swim- ming in lbs. A- voird- pois.	Weight of Grain really Steeped in lbs.	Hours in Steep.	Swell per cent. in Steep.	Swell per cent. in Couch.	Days on Floor.	Clean Malt in Bushels.	Weight of Clean Malt per Bushel. lbs.	Appa- rent loss of Weight per cent.	BUSHELS of MALT.		POUNDS of MALT.		
														From 100 Bushels Grain.	From 100 lbs. Grain.	From 1 Bushel Grain.	From 1 lb. Grain.	
ENGLISH.																		
Norfolk	50.57	150	2.56	147.44	58.00	7527.50	115	24	29.6	15	161.00	38.437	18	109.19	2.113	41.972	0.822	
Norfolk	51.00	150	3.50	146.50	70.87	7579.20	88		22.0	13	152.13	37.562	24.6	103.86	2.007	39.013	0.784	
Suffolk	48.845	80	3.12	76.87	85.00	3822.49	87	37.9	37.9	9	82.77	36.5	21	107.67	2.165	39.229	0.790	
Kent	50.062	80	2.25	77.75	62.87	3942.13	84	27.8	33.2	9	84.87	39.125	16	109.13	2.165	42.612	0.842	
Kent	49.945	150	4.43	145.57	112.37	7385.24	89		25.6	12	153.00	36.875	23.46	105.31	2.072	38.823	0.765	
Average	50.084						92	29.9	29.6	13		37.699	20.61	107.03	2.104	40.343	0.794	
SCOTCH.																		
Berwick & Hadding ⁿ	50.53	126	1.50	124.50	44.00	6323.00	97		19.4	16	125.69	38.501	23.46	100.95	1.990	38.865	0.765	
Hadding ⁿ	52.26	150	1.25	148.75	32.81	7807.03	118	22	25.8	19	153.50	37.298	27	103.19	1.960	38.490	0.733	
Perth	48.19	66	1.90	64.10	48.37	3192.51	64		14.2	10	62.12	39.531	21.6	96.91	1.983	38.310	0.784	
Fife	48.51	100	1.45	98.55	36.12	4834.25	47½		19.6	11	92.68	40.039	23.24	94.04	1.917	38.669	0.767	
Average	49.87						81.6	22	19.7	14		38.842	23.82	98.77	1.962	38.583	0.762	
Big.																		
Kirkcud.	46.87	150	4.56	145.44	112.16	6109.10	89	15	19.5	15	147.25	36.400	26.5	101.24	2.128	36.853	0.744	
Ayr	47.94	150	2.84	147.16	77.00	7113.62	66½		14.2	16	148.75	37.832	20.89	101.08	2.091	38.330	0.791	
Angus	47.03	108	3.12	104.87	85.87	4993.50	83	21	27.4	8	101.53	37.547	24.70	96.81	2.033	36.349	0.763	
Angus	47.39	150	4.34	145.66	119.72	6989.46	87		21.6	13	137.73	38.570	24.8	94.55	1.971	36.083	0.753	
Mearns	47.91	126	1.82	124.18	51.87	5985.27	57		21.3	13	119.87	37.55	24.8	96.52	2.004	36.238	0.752	
Average	47.42						70.45	18	20.8	13		37.579	24.33	98.06	2.045	36.770	0.760	
3d Quality.																		
ENGLISH.																		
Norfolk	51.937	150	1.75	148.25	46.0	7744.64	91	22	28.2	12	157.75	36.68	28	106.41	2.087	39.033	0.747	
Norfolk	51.625	150	2.47	147.53	60.5	7663.70	84		27.1	14	153.14	37.61	24.8	104.50	1.998	38.774	0.759	
Essex	47.633	90	3.59	86.44	107.2	4179.72	98	30	34.5	13	92.06	35.12	23	106.55	2.202	37.423	0.770	
Essex	48.414	100	3.87	96.12	119.6	4721.77	82	22.4	26.3	10	101.50	36.86	21	105.83	2.149	38.923	0.794	
Essex	48.000	100	3.50	96.50	84.0	4716.00	73		28.0	10	98.56	35.66	25.5	102.13	2.090	36.417	0.745	
Essex	46.410	100	6.25	93.75	159.0	4482.37	45		20.5	11	91.26	38.67	21	97.66	2.086	37.772	0.790	
Average	49.004						78	24.8	27.4	11		36.76	23	108.84	2.085	38.057	0.767	
SCOTCH.																		
Berwick	48.854	150	2.22	147.78	64.0	7263.63	74		15.2	14	145.14	37.31	25.4	98.21	1.998	36.656	0.747	
Hadding ⁿ	48.969	150	2.90	147.10	78.0	7267.30	97	20	19.7	15	149.43	36.82	24.3	101.58	2.056	37.389	0.757	
Linlithg ^w	46.940	66	2.78	63.22	77.2	3021.14	47		13.6	10	58.34	40.16	22.5	92.28	1.981	37.057	0.777	
Linlithg ^w	46.375	66	2.00	64.00	57.5	3003.25	49		20.7	9	59.78	39.09	23.5	93.41	1.990	35.980	0.767	
Fife	49.744	66	0.75	65.25	20.5	3262.22	56		17.5	11	59.72	40.81	25.3	91.52	1.831	37.353	0.747	
Angus	46.965	66	2.50	63.50	61.7	3037.82	53		20.8	10	64.22	36.41	23.0	101.13	2.114	36.817	0.777	
Average	47.974						62		17.9	11		38.43	24.0	96.35	1.986	36.877	0.767	
Big.																		
Kirkcud.	44.722	150	6.09	143.91	235.6	5473.00	65		10.6	14	136.00	35.03	26.4	94.5	2.101	33.108	0.737	
Aberdeen	44.086	40	2.25	37.75	66.0	169.74	77	22	23.1	8	39.62	33.50	22.0	105.0	2.334	35.164	0.747	
Average	44.404						71		16.8	11		34.26	24.2	99.7	2.217	34.136	0.737	

Brewing. Thus it appears that the process of malting is nothing else than causing the barleycorns to germinate, and stopping that process before the green leaf makes its appearance. A quantity of roots are formed, which are afterwards rubbed off and separated, and the weight of which amounts to about 4 per cent. of the grain malted. The kernel of the grain undergoes a remarkable change by this process. It consists almost entirely of starch; but it was agglutinated in the grain, so as to make a solid and very firm mass; whereas, in the malt, it is quite loose and mealy. Hence it would appear that the glutinous and mucilaginous matter of the barleycorn is chiefly employed in forming the roots; and that this is the purpose for which it was laid up in the grain. How far the starch is altered does not appear. It is probable that it has undergone some change. Malt has a slightly sweet taste, much more agreeable than the taste of the raw grain, without any of that strong and cloying sweetness which distinguishes wort. But the most distinguishing character of the starch of malt is the ease with which it dissolves in hot water; though cold water does not act upon it sensibly. Whether this property be peculiar to the starch of barley or be induced by the malting, we cannot say. We conceive it probable that barley starch is more easily soluble in water than wheat starch, from the ease with which raw grain is constantly employed by distillers to form their worts. In its other chemical characters, the starch of barley malt agrees with that of wheat starch.

Nature of the Process. We would err very much, however, were we to suppose that the whole kernel or starchy part of the malt is dissolved by the hot water used in brewing. At least one half of the malt still remains after the brewing is over, constituting the grains, which are known to constitute a most nourishing article of food for cattle, and therefore to contain much more than the husks or skin of the malt corn. One hundred lbs. of malt, from different kinds of grain, after being exhausted as much as usual of the soluble part of the kernel by hot water, were found to weigh as follows:—

English barley	-	50.63 lbs.
Scotch barley	- -	50.78
Scotch big	-	52.69

100 lbs. of raw grain being converted into malt, and the soluble part of the malt extracted by hot water, the residue weighed:

English barley	-	51.558 lbs.
Scotch barley	- -	50.831
Scotch big	-	53.500

In another set of experiments, 100 lbs. of malt left the following residues:

English barley	-	54.9 lbs.
Scotch barley,	- -	56.9
Scotch big,	- -	56.6

100 lbs. of the raw grain being converted into malt,

and the soluble part of the malt extracted by hot water, the residues weighed:

English barley	-	54.8 lbs.
Scotch barley	- -	56.9
Scotch big	- -	56.6

Hence we see that, in all these cases, the bulk of the malt was very nearly the same as the previous bulk of the barley before it was malted.

In another set of experiments, 100 lbs. of malt left the following residues:

English barley	-	54.0 lbs.
Scotch barley	- -	56.1
Scotch big	- -	56.6

100 lbs. of the raw grain being converted into malt, and the soluble part of the malt being extracted by hot water, the residues weighed:

English barley	-	54.63 lbs.
Scotch barley	- -	56.09
Scotch big	- -	56.59

Here also the bulk of the malt differed but little from that of the raw grain. The first of these sets of experiments was made with grain of the best quality, the second with grain of the middling quality, and the third with grain of the third quality.

It is probable that an additional portion of the kernel would be dissolved if the malt were ground finer than it is customary to do. The reason for grinding it only coarsely is to render it less apt to set. But this object might be accomplished equally well by bruising the malt between rollers, which would reduce the starchy part to powder, without destroying the husk. This method, indeed, is practised by many brewers, but it ought to be followed by all.

CHAP. IV.

OF BREWING.

Brewing consists of five successive processes, which are distinguished by the following names: 1. *Mashing*, 2. *Boiling*, 3. *Cooling*, 4. *Fermenting*, 5. *Cleansing*. We shall afterwards give a description and view of the utensils employed in a large London porter brewery, where they have been carried to the greatest perfection. But we conceive it better to give a description of the processes themselves, in the first place, without referring them to any specific form of vessels; observing only, that the size of all the utensils must be proportional to the quantity of beer which it is proposed to make at once.

1. The specific gravity of malt varies a good deal, according to the way in which it is dried upon the kiln. But its mean specific gravity may be stated at 1.201. In general the specific gravity of big malt is rather inferior to that of malt from barley. Let us suppose, for the sake of stating the comparative quantities, that it is our object to employ in a

Brewing. single brewing 50 bushels of malt. The first thing to be done is to grind the malt in a mill, and the best kind of mill for the purpose, is that in which the malt is made to pass between two iron rollers.

Mashing. We must be provided with a copper boiler, capable of containing at least the 50 bushels of malt; or its solid contents must, at the smallest, amount to 382 ale gallons, which are rather more than 107,521 cubic inches or $62\frac{1}{2}$ cubic feet. This copper boiler must be placed over brick work upon a furnace, and there must be conveniences for filling it with water and for letting the water off, when sufficiently heated, into the mash-tun.

The mash-tun is a wooden vessel composed of staves properly fixed by means of iron hoops, and usually placed in the middle of the brew-house. It has a false bottom full of holes at some little height above the true bottom. Its capacity varies according to the extent of the brewery establishment. But a mash-tun, capable of mashing 50 bushels of malt, must be, at least, one-third larger than the bulk of the malt, or it must be capable at least of containing 75 bushels.

A quantity of water equal, at least, in bulk to that of the malt, is to be put into the boiler, and heated up to 190° or 180° according to the fancy of the brewer and the quality of the malt. But the best brewers, in general, employ the lowest temperature. This water is then to be let into the mash-tun, and the malt, previously ground, is to be let down into it immediately after. It is then mixed with the water and all the clots carefully broken, either by workmen, who use for the purpose very narrow wooden shovels, or, when the capacity of the mash-tun is very great, as in the London breweries, by a machine which is driven by a steam-engine. Great care must be taken to break all the clots, because the whole of the malt within them would otherwise escape the action of the water, and be lost to the brewer. When the water and malt are sufficiently mixed, the mash-tun is covered and left in this state about three hours. But the time varies according to circumstances.

Though the specific gravity of a malt corn be greater than that of water, yet if it be thrown into that liquid it always swims. The reason is, that between the skin and the kernel there is lodged a quantity of air, which it is not easy to drive away. Accordingly, brewers are in the habit of judging of the goodness of malt by throwing a certain quantity of it into water, and, reckoning the grains which fall to the bottom, these indicate the proportion of unmalted grain which the malt contains. Of course the more of them that exist in any given quantity of malt, the worse must the malt be considered. But though malt, when we consider only single corns, is about a sixth heavier than water, yet a bushel of malt does not weigh so much as one-third of a bushel of water. For, on one occasion, the hot-water in the mash-tun, before the addition of the malt, stood at the height of 22 inches. On adding the malt, it rose to the height of 29 inches. The bulk of the water was 51 bushels; that of the malt before grinding $47\frac{1}{2}$ bushels. We see from this, that the real space occupied in the mash-tun by the $47\frac{1}{2}$

bushels of malt, was only seven inches; while the 51 bushels of water occupied the space of 22 inches. Therefore about two-thirds of the bulk of the unground malt consisted of interstices filled with air.

The temperature of the water is considerably lowered when it is mixed with the malt, but we have been unable to determine how much, from the impossibility of thrusting a thermometer down to the centre of the mash-tun, the only place that would give a correct result. But we may state a few out of the many observations which we have made on the subject: 51 bushels of water of the temperature 192° were mixed with $47\frac{1}{2}$ bushels of malt; after mixture, the temperature at the surface of the mash was 140° . Two hours and a half after, when the wort began to run off, its temperature was 156° , and at that time the surface of the mash was at the temperature of 136° . If we suppose in this case, that the whole mash lost four degrees as well as the surface, and take the mean between the bottom and top, we shall have the mean heat of the whole after the mashing, 150° . So that the water has lost 32° of heat, while the malt (its temperature before mixture was 48°) gained 102° .

The weight of the water, reckoning	
it at 51 bushels, was	3965.25 lbs.
That of the malt was	1788.80 lbs.

This would make the specific heat of the malt 0.69, which is probably considerably above the truth. For, according to the experiments of Dr Crawford, the specific heat of barley is only 0.421. So that our supposition, that the mean temperature after mashing was only 150° , is not quite accurate. Were we to suppose the specific heat of malt to be 0.42, which cannot be very far from the truth, in that case the mean temperature, after mashing, would be 169° , if the water was 192° and the malt 48° , and the weight of each as above stated.

In another experiment, in which 60 bushels of malt were mashed, the heat of the water was 180° , that of the malt 56° , the temperature, on adding the malt to the water and mixing it well, was at the surface 141° . Four hours after, when the wort began to be drawn off, its temperature was 150° , and that of the surface of the mixture of malt and water in the mash-tun, was 138° .

The bulk of water was $66\frac{1}{2}$ bushels, its	lbs.
weight	5147
The weight of the malt was	2283.6

Any person may easily, from these data, calculate what the heat of the mixture after mashing ought to be, supposing the specific heat of the malt to be 0.42. The common formula for the calculation, is $S = \frac{W \times w - m}{B \times m - b}$, in which S denotes the

specific heat of the malt, W the weight of water used, w its temperature, B the weight of malt used, b its temperature, and m (which in the present case is the quantity sought) the temperature after mix-

Brewing. ture. We do not think it worth while to give any more examples of these changes of temperature, though we are in possession of abundance of them; because we do not conceive that they can lead to any useful results.

Wort. After the mash has continued for about three hours (or longer or shorter according to circumstances), a stop-cock, placed below the false bottom in the mash-tun, is opened, and the wort allowed to run out into a vessel prepared to receive it, and known by the name of *underback*. At the same time the cover is taken off the mash-tun, and quantities of water of the temperature of 180° are occasionally sprinkled over it from the boiler, which had been again filled with water to be heated, as soon as the water for mashing was drawn off. No specific directions can be given respecting the quantity of hot-water added in this manner by sprinkling, because that must depend upon the views of the brewer. If he wishes to have ale of very great strength, he will of course add less water; if the ale is to be weak he will add more. The best way is to determine the strength of the liquor as it flows into the underback by means of a saccharometer, or by taking its specific gravity. When the specific gravity (at 60°) sinks to 1.04 or 1.05, or when it contains only 36½ or 46½ lbs. *per* barrel of solid matter in solution, it would be useless or injurious to draw any more off for making strong ale. But an additional portion may still be drawn off and converted into small beer. We have seen the brewers in Edinburgh continue to draw off small beer from the mash-tun till the liquid indicated only 23½ lbs. *per* barrel, or even till it indicated only 17½ lbs. *per* barrel; that is, till its specific gravity at 60° was reduced to 1.027 or 1.020. Indeed the strength of small-beer is often much weaker than this, when it is obtained from malt without drawing off any strong ale wort; but when it is the residue of strong ale, it is necessary to make it stronger, otherwise its quality will be bad. About a dozen of years ago, it was customary with some of the small-beer brewers in Edinburgh, to make the small-beer of considerable strength; and after the Excisemen had determined its quantity, and the duty to be paid on it, they diluted it largely with water, just when they were sending it out of the house. This fraud was easily put in practice, because the small-beer is usually disposed of the moment it is mixed with the yeast, and before it has undergone any fermentation whatever. It ferments sufficiently in the small casks in which it is sent to the consumers. In Edinburgh it is customary to bottle this small-beer, which makes it clear and very brisk, and consequently very agreeable to the palate.

Neither can any general rule be laid down for the specific gravity or strength of the wort, when it begins to flow from the mash. It will obviously depend upon the goodness of the malt, and upon the quantity of mashing water employed, when compared with the quantity of malt. We have seen it begin to flow from the mash-tun of the specific gravity 1.084, 1.0805, 1.0815, 1.0835, 1.091, 1.094; or containing respectively 78½, 74½, 75½, 78, 85, and 87½ lbs. *per* barrel.

VOL. II. PART II.

Brewing. The wort, as it first flows from the mash-tun, is a transparent liquid of a fine amber colour, a peculiar smell, and a rich, luscious, sweet taste. If it is cloudy, as sometimes happens, it is a proof that the water used for mashing was of too high a temperature. We have seen the wort run cloudy from the mash-tun, when the temperature of the water had been as high as 200° or 191°, but never when it was no higher than 180°. This affords an additional reason with the brewers for keeping the temperature of the mashing-water low. But we have some doubts about the accuracy of the reason. For, when the wort is afterwards boiled, it always deposits a copious flocky sediment. The boiling would doubtless render even turbid wort transparent, and would not probably increase the sediment much. At the same time, it must be acknowledged, that some obscurity hangs upon this part of the process of brewing. For we have seen wort continue opaque during the whole process of boiling, cooling, and fermenting, and requiring ultimately to be clarified or *fined*, as the brewers termed it, by means of isinglass. The substance which rendered the ale in this case turbid, seemed to be a variety of starch, or some particular form of that substance; for it was completely precipitated by infusion of nutgalls, and the precipitate was redissolved by the application of a moderate heat.

The flowing of the wort from the mash-tun takes up six or eight hours. As it advances, the colour diminishes, the smell becomes less agreeable, and the taste less sweet. At last the colour becomes nearly opal, and the smell becomes sour, and somewhat similar to the odour given out by an infusion of meal and water left till it has become sour. Yet it produces no change on vegetable blue colours.

If the wort which first comes over be evaporated **Constituents** to dryness, it leaves behind it a yellow-coloured **of Wort.** residuum, which has a sweet taste, dissolves readily in water, absorbs water from the atmosphere, and becomes clammy, and similar in appearance to treacle. Its specific gravity is 1.552. This does not differ much from the specific gravity of common refined sugar, if we take a mean of the experiments of Fahrenheit and Hassenfratz. Fahrenheit found the specific gravity of sugar 1.6065, while Hassenfratz found it 1.4045, the mean of which is 1.5055. There can be no doubt that this residue contains a good deal of sugar, precisely the same in its properties with the sugar into which starch is converted by boiling it in a very dilute acid. But it is mixed likewise with a considerable portion of starch, which has become soluble in water, without being converted into sugar. For wort gives a copious precipitate with the infusion of nutgalls, and this precipitate is redissolved by a moderate increase of temperature, properties which characterize starch.

From the experiments of Saussure it would appear, that starch sugar is nothing else than a combination of starch and sugar. Hence it is probable, that, during the mashing, a combination takes place between the starch of the malt and the water, the result of which is the formation of starch sugar. This sugar agrees in its properties with the sugar of grapes. It crystallizes in needles grouped together

30

Brewing. in the form of small spherules like granulated honey. It does not go so far in sweetening as common sugar; and, like sugar of grapes, it ferments without the addition of yeast. We have attempted in vain to separate the saccharine part of the residue of wort from the starch. When alcohol is poured over it, no solution takes place, but such is the affinity of the residue of wort for water, that it deprives the alcohol of a portion of its water, just as carbonate of potash or muriate of lime does, and a very viscid liquid, consisting of the residue of malt dissolved in a very small quantity of water, is formed at the bottom of the vessel.

It is exceedingly difficult to evaporate wort, without partly decomposing the extractive residue. The best way is to put it upon a very flat dish, and to apply a heat not greater than 120°. We have charred it completely in a glass vessel, filled with alcohol, without applying heat sufficient to make the alcohol boil. Indeed, we never succeeded in obtaining the residue of wort, without its colour being a good deal darker than that of the wort from which it was obtained.

The wort which runs off last contains very little saccharine matter; but some starch and mucilaginous matter may still be detected in it. The flavour and beauty of the ale is increased, if we take only the wort that runs first off, and throw away the last drawn worts, or employ them only in the manufacture of small beer.

Boiling the Wort.

2. The next process in brewing is the *boiling* of the wort. The wort is pumped up from the *under-back* into the copper boiler, where it is boiled for several hours, till it has acquired the degree of strength which is wanted by the brewer.

It may be proper to give some examples of quantities to enable the reader to form a better idea of the effect of the boiling.

From 60 bushels of malt there were obtained 23.465 barrels of wort, of the strength of 64.37 lbs. *per* barrel, or of the specific gravity 1.0683. It was boiled down to 19.736 barrels of the strength of 82.7 lbs. *per* barrel, or of the specific gravity 1.089.

From 60 bushels of big malt there were obtained 23.8193 barrels of the specific gravity 1.0648, or of 58.75 lbs. *per* barrel of saccharine matter. It was boiled down to 19.736 barrels of the specific gravity 1.078, or of 72½ lbs. *per* barrel of saccharine matter.

From 72 bushels of malt 15.1388 barrels of the specific gravity 1.071, or of 60.6 lbs. *per* barrel, it was boiled down to 13½ barrels of the specific gravity 1.1055, or of 98½ lbs. *per* barrel of saccharine matter.

From 50 bushels of malt 13.444 barrels of wort were obtained of the specific gravity 1.068, or of 63.125 lbs. of saccharine matter *per* barrel. It was boiled down to 11.083 barrels of the specific gravity 1.1015, or of 94½ lbs. *per* barrel.

Various contrivances have been fallen upon to economize the boiling process; but these will come under our consideration with more propriety when we give an account of the utensils in a London brewery.

The flocky precipitate which forms during the

Brewing. boiling of the wort, as far as we have been able to determine its properties, approaches nearly to the nature of gluten, or vegetable albumen; for these two substances differ very little from each other.

While the wort is in the boiler, the requisite quantity of hops are added to flavour the ale, and render it capable of being kept for a considerable length of time without souring. Hops, as is well known, are the seed-pods of the *Humulus lupulus*, or *hop-plant*, which is cultivated in considerable quantities in the south of England, especially in Kent and Hampshire. The seed-pods of this creeping plant are collected when ripe, and dried upon a kiln. They are then packed up in bags, and sold to the brewers. Hops are well known to have a peculiar bitter taste, and a weak aromatic odour, and to possess sedative qualities to a considerable extent. A pillow, filled with hops, has often been found to induce sleep, when every thing else has failed. If they be digested for some days in alcohol, that liquid acquires a slight greenish colour, a peculiar taste, and an odour in which that of the hop can be distinctly perceived. If the alcohol, previously freed from the undissolved matter, be distilled in a retort, there remains behind a solid green-coloured oil. It is to this oil that hops owe their peculiar smell. Its taste is peculiar, sharp, and scarcely bitter, but putting one in mind of the peculiar flavour of good ale. This oil is the part of the hops which gives ale its distinguishing flavour. It is apt to be dissipated by long boiling. Hence, when hops are too long boiled in wort, the aromatic odour and peculiar flavour are nearly dissipated, and a bitter taste substituted in its place. It is the opinion of brewers, that the intoxicating qualities of ale are to be partly ascribed to the oil of the hop. Indeed, it has been pretty common to ascribe intoxicating qualities to bitter tasted substances in general. Thus, a woman of the name of Johnston, who kept a public house a little to the south side of the Meadows, near Edinburgh, about the beginning of the last century, was famous for brewing a pleasant and very intoxicating ale; and the last quality was universally ascribed to the broom tops, which she employed as a bitter instead of hops. This woman's name is remembered, because her ale and her house are celebrated in the poems of Allan Ramsay. But this opinion, though very general, does not appear to be founded upon any precise experiments or observations. We are not acquainted with any volatile oil which produces intoxication; though some of them, as oil of turpentine, act with great energy upon the stomach. No infusion of any bitter whatever, not even of hops, is known to produce intoxication; nor is any effect in the least similar to intoxication produced when considerable quantities (2 oz. for example, *per* day) of Peruvian bark are swallowed in substance.

Besides the volatile oil, hops contain likewise a quantity of bitter principle, which may be easily extracted from them by water. As far as we were able to determine the point, this bitter matter possesses the characters of the bitter principle in perfection. No reagent that we tried is capable of throwing it down except acetate of lead, a somewhat ambiguous precipitant, because it throws down the greater number of vegetable substances, and because

Brewing. the lead in this salt is partially thrown down by carbonic acid, if it happens to be present in the solution. Nitrate of silver is likewise a precipitant; throwing down the bitter principle of hops in light yellow flocks. But this precipitant is also somewhat ambiguous, for the same reason that renders acetate of lead so. The bitter principle of hops is likewise very soluble, both in water and alcohol.

Hops communicate both their flavour and their bitter taste to wort. The quantity employed varies very much, according to the taste of the persons who are to drink the ale. The stronger the ale is, the greater the quantity of hops is which it can bear without injury. In general, English brewers employ a much greater quantity of hops than the Scotch brewers. To elucidate the subject, we shall give a few examples of the quantity of hops used in making Edinburgh ale; which is known to be mild, and, in general, is much relished by most of those who are in the habit of drinking ale.

Sixty bushels of malt yielded 11½ barrels of strong ale wort (measured at the end of the boiling), and 40 lbs. of hops had been mixed with it in the boiler.

Forty-seven and a quarter bushels of malt furnished 10.83 barrels of wort, measured after being boiled and cooled, and 36 lbs. of hops had been mixed with it in the boiler.

Sixty bushels of malt furnished fifteen barrels of wort, measured after boiling and cooling, and 45 lbs. of hops had been mixed with it in the boiler.

Sixty bushels of malt, from big, furnished 14.7 barrels of wort, after being boiled and cooled. It was mixed with 40 lbs. of hops in the boiler.

In another brewing in which 72 bushels of malt, from big, furnished 10½ barrels of wort, 66 lbs. of hops had been added in the boiler.

In general, when the ale has considerable strength, the Edinburgh brewers are in the habit of adding one pound of hops for every bushel of malt employed. Sometimes, indeed, when they wish their ale to be very superior in flavour and quality, they employ a greater quantity of hops than even this. Thus, we have seen 100 lbs. of hops boiled in the strong ale wort extracted from 72 bushels of malt. When the ale is but weak, and consequently cheap, the usual allowance is one pound of hops to a bushel and a half of the malt.

Cooling the Wort. 3. After the wort has been boiled down to the requisite strength, which, in Edinburgh, is commonly between the specific gravities 1.09 and 1.10, it is let out into the coolers. The coolers are floors of wood, surrounded with a wooden ledge, and water tight, placed in the most airy and exposed situation in the brewery. They are of such a size as to hold the whole of the wort at a depth not exceeding three or four inches; so that, in large breweries, they are of an enormous extent. The object is to cool down the wort, as rapidly as possible, to the temperature of the atmosphere; because, if it were allowed to remain long hot it would run the risk of becoming sour, which would spoil the whole process. A great deal of the superiority of some breweries over others, depends upon the construction of the coolers, or, rather, upon their being as well adapted as possible for reducing the temperature of the wort speed-

ily to that of the atmosphere. A free current of air ought to pass over them, and great care should be taken to keep them perfectly clean.

The wort is either pumped out of the boiler into the coolers, or it is let into them by simply opening a stop-cock, according to the construction of the brew-house. It soon spreads itself over all the surface of the coolers, and a very great evaporation is the consequence. This evaporation ought always to be taken into consideration by the brewer; because it both materially adds to the strength of the ale and diminishes its quantity. The amount of it depends upon the temperature of the air compared with that of the atmosphere, and upon the skill with which the coolers have been constructed. We shall give a few examples of the quantity of evaporation which took place during the cooling of worts, in coolers by no means remarkable for the goodness of their construction.

Temperature of the wort when let into the coolers.	Temperature of do. when cold.	Quantity of Wort when let into the Coolers in Ale Barrels.	Ditto when cooled.	Quantity evaporated in Ale Barrels.	Time of Cooling in hours.
160°	56°	16.1388	14.8611	1.2777	11½
176°	51	18.6666	17.2222	1.4444	11½
208°	50	11.5555	8.75	2.8055	9½
208°	52	16.6388	12.0832	4.5556	14
208°	50	14.0555	10.2222	3.8333	9
208°	53	14.7777	10.5	4.2777	16
210°	52	13.6944	9.1388	4.5556	8
208	51	13.3333	9.3055	4.0278	8
206	52	12.6388	8.2777	4.3611	6
200	52	14.0555	9.4444	4.6111	6½
200	54	13.6944	9.1388	4.5556	6
200	53	11.0833	8.5000	2.5833	7
204	56	14.0555	10.6111	3.4444	8
Mean		14.1067		3.5640	

In the first two examples in the above Table, the quantity of wort was estimated just when it was let down into the coolers; in all the others it was estimated in the boiler before it was pumped out. It appears from the preceding table, that rather more than one-fourth of the whole wort is dissipated by evaporation during the cooling. And, if we had excepted from the general consideration the two first examples, the proportion evaporated would have been still greater.

When the wort is let out of the boiler into the

Brewing.

cooler, the hops still remain, and, as they are soaked with wort, a considerable loss would be sustained if they were thrown away. Thus we found, in one instance, that 45 lbs. of hops retained half a barrel of wort after they were drained so completely that no more wort would drop out. In another case, 35 lbs. of hops, retained in the same way, 0.3666 of a barrel, which is rather more than one-third of a barrel. To recover this wort it is proper to subject the hops to pressure. We do not know whether this is attended to by the great brewers, though it probably is. By several of the Edinburgh brewers it is too much neglected.

In cold weather, where the brewery is small, and the apartment in which the fermenting vessels are placed, cold, it is proper not to reduce the temperature of the wort so low as that of the atmosphere. From want of attention to this circumstance, we have seen wort refuse to ferment for some time, and the brewer under the necessity of heating it artificially before fermentation could be brought on. In such cases, the wort is very apt to be lost altogether by contracting acidity. The temperature, in such cases, ought not to be reduced lower than 56°. But when the apartment in which fermentation is carried on is warm, 51° or 52° is a very good temperature. When the brewer is obliged to make ale in warm summer weather, it is material to reduce the temperature as low as possible. In such cases, great advantage would attend cooling the wort in coolers without any roof or covering whatever, but quite open to the sky; because, in clear nights, the wort might be cooled in this way, eight or ten degrees lower than the temperature of the atmosphere. The reason is obvious. It is owing to the rays of heat, which, in such a case, radiate from the wort, and are not returned again by the clear sky. Wort, being a good radiator of heat, would be particularly benefited by this method of cooling. We have no doubt that it might be put in practice with advantage in hot climates; and that, by means of it, good ale or porter might be manufactured in the East and West Indies. Such a manufacture, if successful, would be particularly relished in India, and would, we doubt not, prove a lucrative article of manufacture to an enterprising man.

As there is a duty levied on ale and beer according to their quantity, Excisemen are in the habit of gauging the wort while in the boiler and when on the coolers. Not that the duty is levied according to the quantities there found; but to serve as a check upon the more accurate gauges taken in the fermenting tuns. For a certain allowance being made for evaporation, while the wort is in the cooler, which the excisemen, from long observation, are enabled to do with some accuracy, they have it in their power, from these checks, to determine whether any of the wort from the coolers has been secreted or carried off with a view to evade the excise laws.

Fermentation.

4. When the wort is sufficiently cooled down by exposure on the coolers, it is let down into the fermenting-tuns, or, as the brewers call them, the gyle-tuns, in order to be fermented; by which process, it is converted from the luscious sweet-tasted liquor

called *wort*, to the brisk intoxicating liquor which constitutes *ale*. The gyle-tuns are cylindrical wooden vessels, varying in size, according to the extent of the brewery. In the London breweries, and in the distilleries, they are of prodigious size; but in private houses they often do not exceed the size of a wine hogshead, or even of a beer barrel. The fermentation is perhaps conducted with the greatest economy in large vessels; but good ale may be made in comparatively small quantities. How far this is the case with porter, it is more difficult to say. Good porter has scarcely ever been made, except by those who manufacture it upon a large scale.

The fermenting tuns are not to be filled by the wort; because a considerable increase in bulk takes place during the fermentation, in consequence of which the liquor would run over, unless allowance were made for it.

The fermentation of ale or beer is never carried to any great length. The object of the brewer is, to retain the flavour and good qualities of the ale or beer, not to develop the greatest quantity of spirits, which can hardly be done without allowing the wort to run into acidity. The violence of the fermentation depends upon the quantity of yeast added. Brewers, accordingly, mix yeast with their worts only in very sparing quantities; while the distiller adds it in great doses, and repeatedly.

Yeast is a frothy substance of a brownish-grey colour, and bitter taste, which is formed on the surface of ale or wine while fermenting. If it be put into sacks the moisture gradually drops out, and the yeast remains behind in a solid form. It has very much of the flavour and taste of cheese when in this state; but its colour is still darker. This dried yeast promotes or excites fermentation; but it does not answer quite so well as fresh yeast. At one period, some of the Scotch distillers employed considerable quantities of it; but all of them with whom we conversed on the subject, affirmed, that it was much less profitable than even the bad porter yeast which they were in the habit of bringing down from London. From the resemblance which dried yeast has to cheese, one would be disposed to infer that it is a species or variety of gluten. But if we attempt to induce fermentation in wort by adding the gluten of wheat, we will be unsuccessful.

When yeast is kept for some time in cylindrical glass vessels, a white substance, not unlike curd, separates and swims on the surface. If this substance be removed the yeast loses the property of exciting fermentation. This white substance possesses many of the properties of gluten, though it differs from it in others. Its colour is much whiter, it has not the same elasticity, and its particles do not adhere with the same force. In short, it agrees much more nearly, in its properties, with the curd of milk than with the gluten of wheat. We are disposed to consider this substance as the true fermenting principle in yeast; though we were never able to procure a sufficient quantity of it to put its fermenting powers to the test of experiment. We have sometimes seen a similar substance separate in the fermenting tuns in distilleries, when the fermentation was nearly at an end; or, rather, when such a quantity

Brewing. of spirit had been generated as put an end to the fermenting process altogether. But we could never learn that the distillers had formed any opinion respecting this curdy substance. It did not interfere with the success of their operations, and, on that account, they bestowed little attention to it. We attempted, once or twice, to collect such a quantity of it as might enable us to try its powers as a ferment, but we did not succeed.

The only chemist who has attempted to subject yeast to a chemical analysis is Westrumb. But, though this philosopher was distinguished for his accuracy, the task was too difficult for the resources of the science of the time (1796) when he published his *Experiments*. From 15360 parts of fresh beer yeast he obtained the following substances:

Potash	-	-	-	13
Carbonic acid	-	-	-	15
Acetic acid	-	-	-	10
Malic acid	-	-	-	45
Lime	-	-	-	69
Alcohol	-	-	-	240
Extractive	-	-	-	120
Mucilage	-	-	-	240
Saccharine matter	-	-	-	315
Gluten	-	-	-	480
Water	-	-	-	13595
				<hr/>
				15142
Loss	-	-	-	218
				<hr/>
Total				15360

As yeast may be reduced to a dried state without depriving it of the power of acting as a ferment, it is clear that the carbonic acid, acetic acid, alcohol, and water are not essential to it. We cannot suppose that either potash, lime, or malic acid, is essential. The saccharine matter, we know, is capable of fermenting of itself; but if it were the essential ingredient, it would be quite unnecessary to add yeast to wort at all, as we know that the wort contains abundance of saccharine matter in solution. We know likewise, from experiment, that neither extractive, mucilage nor gluten possesses the property of exciting fermentation. Thus none of the substances found by Westrumb in yeast, can be considered as the true fermenting principle. Dobereiner found that, when yeast is steeped in alcohol, it loses the property of acting as a ferment. This may be owing to the alcohol dissolving and carrying off the true fermenting principle. But we are rather disposed to ascribe it to the presence of a portion of alcohol in the yeast. We know that a certain portion of alcohol destroys fermentation. Thus we have found by a great many trials, conducted on rather a large scale, that the stronger a wort is made, the greater is the quantity of unaltered saccharine matter which remains in it after the fermentation

Brewing. has been carried to the greatest possible length. Hence the present mode of levying the duties on spirits upon the wash is not only very injurious to the goodness of the spirits manufactured; but is attended with a positive and very heavy loss to the community. Distillers' wash may be fermented a second time, and would in this way yield a considerable additional quantity of spirits. We have frequently seen it made into good small-beer. The proper mode of levying the duty would be on the quantity of saccharine matter in the wash. This might easily be determined by a good *saccharometer*. A certain part of the duty might likewise be levied upon the spirits produced. This would act as a sort of check upon the first estimate, and would considerably diminish the risk of fraud. Indeed, the mode of determining the duty by the quantity of saccharine matter, would not be more liable to evasion than the present mode. It could be evaded in no other way than by concealing a portion of the wash, which would be equally efficacious according to the present mode.

We conceive, therefore, that when yeast is mixed with alcohol, it may retain so much of that liquor as to prevent it from acting as a ferment. When we attempt to wash away the alcohol, we may destroy the yeast by washing away that portion of it which really acts as a ferment, which is probably small in quantity.

It seems to us not unlikely, that the portion of yeast which really acts as a ferment, is a quantity of saccharine matter which it contains, that has begun to undergo the decomposition produced by fermentation, but has not yet completed the change. For nothing more seems to be necessary than to begin the fermentative process in wort; the process then goes on of itself. It would be curious to know whether a high temperature (96° or 100°) might be substituted in distilleries for the great quantities of yeast at present employed. We believe that the reason why such great quantities of yeast are necessary in distilleries, is the very great strength of the wash employed; as they are obliged by law to produce a quantity of proof spirits amounting nearly to $\frac{1}{4}$ th of the whole bulk of the wash. Nothing can be more preposterous than such a method, nor more contrary to the real interest of the community, which obviously must be to produce the greatest quantity of good spirits from a given quantity of grain.

The quantity of yeast mixed with the wort in the fermenting tuns by brewers, is very small, amounting, at an average, to a gallon of yeast for every three barrels of wort. The following table will give the reader an idea of the quantities of yeast really mixed by the Edinburgh brewers with their strong ale worts in different brewings. It is obvious, however, that the quantity of yeast must be regulated in some measure by its goodness.

BREWING.

Quantity of wort in barrels.	Specific gravity.	lbs. per barrel of saccharine matter.	Quantity of yeast added in gallons.
10.611	1.106	99	3.5
10.83	1.104	97½	4
14.944	1.096	89½	2.5
14.8055	1.093	86½	3.75
14.6388	1.093	86½	2.83
14.722	1.082	76½	2.83
10.201	1.091	86½	1
9.75	1.091	86½	1
11.478	1.098	91½	1
9.25	1.096	89.67	1

The four last brewings, in which the quantity of yeast added was smaller than in the six first, took place during the month of May, when the heat is apt to make the fermentation run to excess. The variation in the quantity, so conspicuous in the first six brewings, is partly to be ascribed to differences in the goodness of the yeast; but chiefly to the carelessness and want of method which distinguished the brewer in question beyond any one we ever met. But we have taken his quantities, to show that differences in the quantity of yeast are not material; for all the preceding brewings, except the first, furnished very good ale. The wort in the first brewing had been cooled too much; the consequence was, that it fermented very badly, and finally ran into acidity.

Soon after the yeast has been mixed with the wort, an intestine motion begins to appear in the liquid; air bubbles separate from it, and a froth collects slowly upon the surface. This froth is of a yellowish grey colour. At first it has the appearance of cream; but, in a few days, it collects in considerable quantities, especially if the weather be warm. At the same time, the temperature of the wort increases, and a very considerable quantity of carbonic acid gas is given out by it. The increase of temperature which takes place during the fermenting of ale may be stated, at an average, to amount to 12° or 15°. Sometimes it amounts to 20°, and sometimes does not exceed 5°. But, in such cases, there is generally some fault in the skill of the brewer. But the following Table, exhibiting the highest temperatures of different ales during their fermentation, will satisfy the reader of these changes of temperature better than any general explanation:

Quantity of Wort fermented in two Tuns. In Barrels.	Date at which it was let into the fermenting Tuns.	Temperature at that time.	Temperature when at the highest Point of Fermentation.	Date at which this Temperature took place.	Strength of Wort when let into fermenting Tuns, in lbs per Barrel.	Quantity of Yeast added in Gallons.
10.83	March 10.	50°	68°	March 17.	88.75	4
14.944 in 1 tun.	March 17.	55	61	March 21.	85.62	2½
14.8055	March 24.	46	68	April 2.	78.125	3½
14.6388 in 1 tun.	March 29.	57	70	April 2.	80.625	2.83
14.722	March 31.	56	71	April 3.	73.75	2.83
17.43 in 1 tun.	April 4.	51	64	April 10.	65.00	2.83
8.72 in 1 tun.	April 6.	50	65	April 13.	93.75	3½

We shall now give some examples of the change of temperature by fermentation, when the brewings were conducted in summer, and of course assisted by the heat of the weather.

Quantity of Wort fermented in Barrels.	Date of letting it into the fermenting Tun.	Temperature at that time.	Temperature when at highest.	Date of ditto.	Strength of Wort in lbs. per Barrel.	Yeast used in Gallons.
9.75	May 24.	51°	71°	May 30.	95.93	1
11.4782	May 28.	49	72	June 2.	91.56	1
9.25	May 31.	46	67	June 6.	89.37	1
10.2777	June 4.	46	67½	June 13.	105.82	1
10.5	June 7.	44	71	June 15.	102.187	1
10.2222	June 11.	55	82	June 15.	110.0	1
10.694	June 18.	53	80	June 24.	96.4	1
13.5	June 21.	53	67½	June 25.	61.25	1

We shall likewise give the result of two brewings, with raw grain, made also during summer.

Quantity of Wort Fermented in Barrels.	Date of letting do. into the Fermenting Tun.	Temperature at that time.	Temperature when at highest.	Date of ditto.	Strength of Wort in lbs. per Barrel.	Yeast used in Gallons.
10.5555	June 26	48°	62°	July 1.	56.25	1
14.3055	July 6.	58	68°	July 8.	72.5	1½

Brewing. We see, from the preceding tables, that the length of time which elapses before the fermentation reaches its acme (supposing this to be measured by the temperature) varies very considerably. The shortest interval in the table is three days, and the longest nine days; the average of the whole is very nearly six days, which is exactly the mean between the longest and the shortest times. If the reader will glance his eye over the tables, he will perceive that, in general, the higher the temperature of the wort is when let down into the fermenting tuns, the more rapidly does the fermentation come on. As the worts were cooled by exposure to the greatest cold of the night, and as the coolers were screened from the effects of the radiation of heat, the temperatures given in the third column of the preceding tables may be considered as measuring very nearly the greatest degree of cold which took place in Edinburgh at the dates contained in the second column. Hence it follows, as might have been expected, that the warmer the weather, the more rapid is the fermentation. Hence the advantage of letting down the worts rather warm in cold weather, and cooling them down as much as possible in warm weather. For this purpose, we cannot too much recommend coolers which can occasionally be uncovered altogether, and exposed to the unclouded sky. A roof, perhaps, might be contrived, composed of very light materials, which might be easily slid off, or which might turn upon a pivot. For a roof would be occasionally necessary to screen the worts from rain. In warm weather, brewing should be confined to clear and unclouded days, when the cooling process could be carried farthest of all. We have little doubt that wort might easily be cooled down to the freezing point, if requisite, in our warmest summer weather.

Little can be said about the length of time during which the fermentation of ale lasts; because it varies very much according to the heat of the weather, and the degree to which the wort has been cooled down. The following Table will give some idea of the length of time which elapsed during the fermentations contained in the preceding tables:

FIRST TABLE.

1st	-	-	-	8	Days.
2d	-	-	-	10	
3d	-	-	-	10	
4th	-	-	-	8	
5th	-	-	-	9	
6th	-	-	-	9	
7th	-	-	-	10	

SECOND TABLE.

1st	-	-	-	6	Days.
2d	-	-	-	8	
3d	-	-	-	9	
4th	-	-	-	15	
5th	-	-	-	10	
6th	-	-	-	7	
7th	-	-	-	7	
8th	-	-	-	7	

THIRD TABLE.

1st	-	-	-	g	Days.
2d	-	-	-	5	

Brewing.

The theory of fermentation has occupied the attention of chemists ever since the manufacture of ale began to be attended to by men of science; but it is only of late that much light has been thrown upon the subject. Lavoisier was the first person who attempted to give any thing like a theory of this intricate process. He attempted to determine the composition of common sugar, a substance which may be fermented just as well as the soluble part of malt, and which yields similar products. He endeavoured, likewise, to determine the constituents of alcohol, the substance formed by fermentation. With these data, and with a knowledge of the composition of water and carbonic acid, he formed a plausible theory, which was valuable as a first approximation, though there can be little doubt that it was erroneous in every particular. Since that time, several experiments on the subject have been made by Thenard, Guy-Lussac and Thenard, and Berzelius, have determined the constituents of sugar with much care; and Theodore de Saussure has made very elaborate, and, we believe accurate, experiments on the composition of alcohol. These facts will enable us to form a conception of what takes place during fermentation. We shall first state the general theory, as resulting from experiments on common sugar, and then give some experiments, which we ourselves have made on the saccharine matter of malt.

If a weak solution of sugar in water be kept in a warm place, it will ferment of itself, and be converted into a spiritous liquor. This we have tried more than once, and always successfully, provided the weather was warm. A solution of sugar of grapes in water ferments still more speedily. This is said, likewise, to be the case with sugar of starch; and, of course, with the saccharine matter of malt. In our general view of fermentation, then, we may leave out of view the small quantity of yeast; because it is not absolutely necessary, but seems merely to render the effect more rapid, and consequently prevent the change of the liquid into acidity, which almost always takes place when the fermentation is slow.

When the fermentation is complete, the sugar disappears altogether, and two new substances are found in its place. These are, carbonic acid and alcohol. All that happens, then, is the resolution of sugar into the two new substances, carbonic acid and alcohol. It is requisite to know how much of each of these substances is formed from a given weight of sugar.

According to Lavoisier's experiments, 100 parts of sugar yielded, when fermented,

Alcohol,	57.70
Carbonic acid,	35.34

He does not give us the specific gravity of his alcohol, but it could scarcely be less than 0.825; for when his experiments were made, alcohol of greater

Brewing. strength was scarcely known. Now, such alcohol contains at least 11 per cent. of water; for that quantity has been actually extracted from it. From Saussure's experiments, it is probable that the real quantity of water contained in alcohol of the specific gravity 0.825, is 18.387 per cent. or almost a fifth. On this supposition sugar, according to Lavoisier's experiments, yields

Alcohol,	-	47.1
Carbonic acid,	-	35.34
		<hr/>
		82.44

or per cent.

Alcohol,	-	57.1
Carbonic acid,	-	42.9
		<hr/>
		100.0

Thenard mixed 60 parts of yeast with 300 of sugar, and fermented the mixture at the temperature of 59°. He informs us, that, in four or five days, all the saccharine matter had disappeared. The quantity of carbonic acid evolved amounted by weight to 94.6 parts. It was perfectly pure, being completely absorbed by water. The fermented liquid being distilled, yielded 171.5 parts of alcohol, of the specific gravity 0.822. When the residue of the distillation was evaporated, 12 parts of a nauseous acid substance remained, and 40 parts of the yeast still continued unaltered in appearance, though Thenard assures us that it had lost the whole of its azote. Thus the products of the fermentations were

Alcohol of 0.822,	-	171.5
Carbonic acid,	-	94.6
Nauseous residue,	-	12.0
Residual yeast,	-	40.0
		<hr/>
		318.1
Loss,	-	41.9
		<hr/>
Total,	-	360.0

But as the nauseous residue and residual yeast, nearly make up the quantity of yeast employed, let us consider only the products of decomposed sugar, supposing the loss to be proportionally divided between the carbonic acid and alcohol. Now, alcohol of the specific gravity 0.822, contains one-tenth of its weight of water, which can be separated from it; and if we suppose, with Saussure, that absolute alcohol contains 8.3 per cent. of water, then the products of sugar decomposed by fermentation, according to Saussure's experiments, are as follows:

Alcohol,	-	47.70
Carbonic acid,	-	35.34
		<hr/>
		83.04

or, in 100 parts,

Alcohol,	-	57.44
Carbonic acid,	-	42.56
		<hr/>
		100.00

This result approaches so nearly that of Lavoisier, that there is reason to suspect that the coincidence is more than accidental.

According to the experiments of Thenard and Guy-Lussac, sugar is composed of

Carbon,	-	42.47
Oxygen and hydrogen in the same proportion as in water,	-	57.53
		<hr/>
		100.00

According to one analysis of Berzelius, it is composed of

Hydrogen,	-	6.802
Carbon,	-	44.115
Oxygen,	-	49.083
		<hr/>
		100.000

and according to another, of

Hydrogen,	-	6.891
Carbon,	-	42.704
Oxygen,	-	50.405
		<hr/>
		100.000

Alcohol, according to the analysis of Saussure, is composed of

Hydrogen,	-	13.70 or 3 atoms.
Carbon,	-	51.98 or 2
Oxygen,	-	34.32 or 1
		<hr/>
		100.00

And carbonic acid is composed of

Carbon,	-	27.3 or 1 atom.
Oxygen,	-	72.7 or 2

Hence it is obvious that sugar can be resolved into alcohol and carbonic acid only, on the supposition that it contains 3 atoms of oxygen, 3 atoms of carbon, 3 atoms of hydrogen,

proportions which do not accord with any of the analyses stated above. Supposing its composition to be so, the weight of each of the constituents per cent. is as follows:

Hydrogen,	-	6.66
Carbon,	-	40.03
Oxygen,	-	53.31
		<hr/>
		100.00

On this supposition, an integrant particle of sugar contains nine atoms, namely, three of oxygen, three of carbon, and three of hydrogen; which are capable of arranging themselves differently, so as to form an integrant particle of alcohol (containing six atoms), and an integrant particle of carbonic acid (containing three atoms).

An integrant particle of sugar is composed

Brewing.

Oxygen. Carbon. Hydrogen.
3 Atoms. 3 Atoms. 3 Atoms.

A particle of alcohol of	1	2	3
A particle of carbonic acid of	2	1	0
	3	3	3

The weight of a particle of alcohol, - 2.877
 The weight of a particle of carbonic acid, 2.751

According to these numbers, 100 parts of sugar ought by fermentation to be decomposed into

Alcohol, -	50.76
Carbonic acid,	49.24
	100.00

or it ought to form very nearly equal weights of each of these constituents.

This explanation of fermentation, though in some points hypothetical, must be admitted to approach pretty near the experiments made upon the subject. These experiments are attended with so much difficulty, that rigid accuracy cannot be expected. In all likelihood, we can never arrive at the truth by any other method than that which we have followed upon this occasion. Nor will this method be any longer doubtful, as soon as it is ascertained with precision, that sugar can be resolved into alcohol and carbonic acid, and as soon as we know the proportions of the two substances evolved. We conceive that both Lavoisier and Thenard have stated the quantity of carbonic acid too low, from not being aware that the whole of the sugar is never decomposed by fermentation. This we conclude from some experiments of our own, made on a large scale, of which we shall now proceed to give an account.

Nine different brewings of pure malt were made. The worts were weak, and they were fermented as strongly as possible by means of large quantities of yeast, added at intervals, as is practised by the distillers. The following table exhibits the specific gravity of these worts before and after the fermentation was over:

Specific gravity of the wort.	Specific gravity of ditto after fermentation.
1.040	1.0014
1.056	1.0016
1.050	1.000
1.0492	1.0012
1.0465	1.0045
1.045	1.0047
1.0465	1.0007
1.051	1.0007
1.0524	1.0004

From this table we see, that only one of the worts was reduced by fermentation so low as the specific gravity of pure water. As a good deal of alcohol was evolved in each by the fermentation, it is obvious that they must have all contained a certain portion of saccharine matter undecomposed, notwith-

VOL. II. PART II.

Brewing.

standing the violence of the fermentation, which elevated the temperature of the worts more than 50 degrees. On evaporating a portion of the worts of each of these brewings, we obtained a quantity of undecomposed saccharine matter, which amounted, at an average, to one-fifth of the quantity originally present. At first they contained, at an average, 45 lbs. per barrel of saccharine matter. The spent wash, after distillation, contained still 9 lbs. per barrel. This liquor was capable, of being fermented a second time, and yielding more spirits.

Now, as these worts were very weak, and as they were fermented in very advantageous circumstances, and in much greater quantities than either Lavoisier or Thenard could have employed in their experiments, we do not conceive that more than four-fifths of the sugar which they employed in their experiments could have been decomposed. Now, if to the carbonic acid actually developed in their trials we add a fifth part, the number will approach very nearly to the one which we have deduced from the supposition that sugar is decomposed by fermentation into an integrant particle of alcohol, and an integrant particle of carbonic acid.

On comparing the quantity of alcohol of 0.825 obtained in our experiments from the quantity of saccharine matter actually decomposed by fermentation, the result was, that 100 parts of saccharine matter yielded almost exactly 50 parts of such alcohol. This would amount to about 40.9 parts of real alcohol. There could be no doubt that a portion of the alcohol was lost during the distillation, which was conducted in the rapid way followed some years ago by the distillers in Scotland. If we suppose one fifth lost, which is probably not much beyond the truth, the real produce of alcohol from the saccharine matter of malt would be almost exactly one half of its weight, which it ought to be, according to the preceding supposition, that it is decomposed into alcohol and carbonic acid.

When the fermentation is languid, it is customary to beat in the yeast which has collected on the top; that is to say, the whole is stirred till the wort and yeast are thoroughly mixed.

5. The last step of the process of brewing is called *Cleansing*. When the violence of the fermentation is over, the head of yeast, which covers the top of the fermenting tun, diminishes in height by the gradual escape of the carbonic acid gas, which heaved it into bubbles. If the wort were allowed to remain in the gyle-tun after this has happened, the yeast would again mix with it; and the consequence would be, a disagreeable bitter taste, known among brewers by the name of *yeast bitter*. The fermentation would likewise continue, though in a languid manner, and the ale would soon run into acidity. These accidents are prevented by drawing off the ale into small casks. This is called *cleansing*. The casks are filled quite full, and left with their bungs open. The drawing off of the ale from the gyle-tun lowers its temperature, and, of course, checks the fermentation. On this account, the cleansing is sometimes practised in summer, when the elevation of temperature in the wort is at its height.

We have repeatedly observed a curious circum-

Brewing. stance, during the cleansing, not very easily accounted for. If you take the temperature of the ale at the upper surface of the gyle-tun, and then observe the temperature of the ale when it flows from the stop-cock at the bottom of the tun, we shall generally find it one or two degrees hotter in this latter place than at the former. We ought naturally to expect the highest temperature at the top of the gyle-tun.

The ale still continues to ferment after it is put into the small casks; but, as these casks are always kept full, the yeast, as it comes to the surface, flows out at the bung, and thus separates altogether from the beer. It is this separation that has induced brewers to distinguish it by the name of *cleansing*: In these casks, then, the yeast divides itself into two portions. The greatest part rises up with the carbonic acid evolved, and flows out at the bung-hole; while another portion subsides to the bottom, and constitutes what is called the *drogs* of the beer. It is essential to the cleansing, that the casks should be always full; otherwise the yeast will not run off, and the beer will not become transparent. This object is accomplished in small breweries by a man constantly going round, and filling up the casks as

they *work down*. But in the London breweries there is an ingenious mechanical contrivance, which answers the purpose perfectly.

When the fermentation has subsided, the beer will in general be found transparent. It is bunged up in the casks, and preserved for sale; or in London, where the quantity is too great for this, the beer is removed into large stone vats, capable of holding several thousand barrels, from which it is gradually distributed to the consumers.

In London, where the beer is usually sent to the public-houses as soon as the fermentation is over, and before it has had time to become fine, it is usual to send along with it a quantity of *finings*, as it is called; that is, a solution of isinglass in weak sour beer, made from a fourth mash of the same malt. The publican puts a certain quantity of this into every cask. It forms a kind of web at the surface of the liquid; and, gradually sinking to the bottom, carries with it all the flocculent matter, and leaves the beer transparent.

We shall terminate this chapter with a Table, exhibiting the results obtained by brewing with malt made from a considerable number of different varieties of barley and big.

GRAIN. <i>1st Quality.</i>	Weight per Bushel. lbs.	Bushels of Malt used.	Weight of Malt per Bushel. lbs.	Wort in Barrels.	Specific Gravity of Worts.	Lbs. per Bar- rel of Dry Extract.	Total Quantity of Dry Ex- tract.	Solid Ex- tract from a Bushel Malt in lbs. A. voirdupois.	Solid Ex- tract from a Bushel of Raw Grain.	Solid Ex- tract from 1 lb. of Raw Grain.
ENGLISH.										
Norfolk - -	50.375	60	36.58	{ 10.611	1.106	99.2	1364.89	22.748	24.91	0.4485
				{ 7.305	1.039	35.25				
Norfolk - -	50.375	47.5	36.58	{ 11.131	1.104	97.25	1071.36	22.588	24.70	0.4843
				{ 9.176	1.108	101				
Norfolk - -	50.375	55	36.58	{ 9.166	1.029	25.5	1153.23	20.976	22.96	0.4563
				{ 14.77	1.084	78.125				
Norfolk - -	50.375	60	38.4	{ 7.972	1.106	99.06	1368	22.8	23.84	0.4733
				{ 8.566	1.030	26.56				
Norfolk - -	50.375	55	38.4	{ 8.38	1.014	11.25	1220.7	22.19	23.20	0.4406
				{ 10.588	1.1197	112.5				
Suffolk - -	50.508	72	40.56	{ 8.527	1.044	40.6	1798.46	24.98	25.99	0.5027
				{ 3.55	1.0124	10.0				
Kent - -	49.750	60	34.88	{ 10.733	1.104	97.25	1925.84	22.095	24.58	0.4941
				{ 7.417	1.033	29.25				
Kent - -	49.914	50	35.76	{ 4.465	1.018	14.75	1139.52	22.79	24.22	0.4863
				{ 8.954	1.106	99.2				
Kent - -	49.922	81.875	35.44	{ 7.305	1.032	28.25	2037.86	24.889	27.06	0.5431
				{ 2.717	1.019	15.5				
				{ 11.488	1.117	110				
				{ 16.222	1.049	45.25				
				{ 2.673	1.008	6.5				
Average	50.208		37.02					22.894	24.54	0.4803
SCOTCH.										
Haddington	52.190	60	38.06	{ 15.456	1.205	98.25	1510.78	25.199	27.46	0.5262
				{ 12.603	1.104	97.25				
Haddington	52.190	72	39.18	{ 12.944	1.040	36.25	1717.74	23.857	24.59	0.4712
Haddington and Berwick	53.094	60	39	{ 14.5	1.092	85.94	1475	24.580	24.73	0.4915
				{ 8.0	1.113	106.25				
Haddington and Berwick	53.094	54	39.6	{ 8.16	1.027	27.5	1328	24.6	24.75	0. 919
				{ 11.995	1.106	99.2				

ewing.

Brewing.

GRAIN. 1st Quality.	Weight per Bushel. lbs.	Bushels of Malt used.	Weight of Malt per Bushel. lbs.	Wort in Barrel.	Specific Gravity of Wort.	Lbs. per Bar- rel of Dry Extract.	Total Quantity of Dry Ex- tract.	Solid Ex- tract from a Bushel Malt in lbs. A- voirdupois.	Solid Ex- tract from a Bushel of Raw Grain.	Solid Ex- tract from 1 lb. Raw Grain.
Edinburgh -	52.164	60	41.92	{ 10.722 2.926	{ 1.033 1.011	{ 24.6 8.8	1525.93	25.432	25.08	0.4808
Edinburgh -	52.164	60	42.26	{ 10.264 9.528	{ 1.111 1.044	{ 104 40.4				
Edinburgh -	52.164	79.125	41	{ 1.807 11.324 16.222	{ 1.013 1.121 1.042	{ 10.5 113.5 38.12				
Fife -	51.539	72	38.8	{ 2.69 13.033	{ 1.009 1.1059	{ 7.25 98.5	1756.24	24.39	24.39	0.4732
Fife -	51.539	72	38.8	{ 7.944 4.138	{ 1.028 1.0075	{ 24.37 5.02				
Fife -	51.539	72	38.8	{ 13.252 8.5 6.235	{ 1.101 1.029 1.0062	{ 94.37 26.56 5				
Average	52.237		38.8					24.696	25.17	0.4876
<i>Bigs.</i> Lanark -	48.562	60	36.44	15.3	1.090	84	1282.16	21.369	22.08	0.4547
Lanark -	48.562	72	36.44	{ 10.9 11.667	{ 1.116 1.040	{ 109 36.25	1625.63	22.578	23.33	0.4804
Perth -	47.854	72	34.44	{ 8.971 9.065	{ 1.111 1.057	{ 104 53				
Perth -	48.562	80	37.57	{ 3.47 12.094	{ 1.016 1.121	{ 13 113.5	2011.38	25.142	24.90	0.5128
Perth -	48.562	60	36.53	{ 13.686 12.672	{ 1.048 1.011	{ 44.25 8.8				
Aberdeen -	48.562	72	36.03	{ 9.809 10.361	{ 1.103 1.034	{ 96.4 30.25	1285.99	21.423	20.87	0.4297
Aberdeen -	48.562	72	36.03	{ 2.455 18.00	{ 1.011 1.115	{ 8.8 108.43				
Aberdeen -	48.562	72	36.03	{ 9.223 6.286	{ 1.040 1.0075	{ 35.25 5.93	1678.61	23.310	23.14	0.4765
Aberdeen -	48.562	72	36.03	{ 14.00 8.25	{ 1.112 1.0307	{ 105 35.92				
Dumfries -	47.000	60	36.81	{ 6.24 14.75	{ 1.006 1.069	{ 5.45 64.37	1299.84	21.66	21.14	0.4498
Average	48.278		36.28					22.424	22.47	0.4646
<i>2d Quality.</i> ENGLISH.										
Norfolk -	50.57	60	38.437	18.135	1.072	67	1234.95	20.583	22.475	0.4444
Norfolk -	50.57	70	38.437	{ 10.874 10.000	{ 1.106 1.041	{ 99.2 37.25	1489.92	21.284	23.241	0.4506
Norfolk -	51	50	37.562	{ 13.694 7.722	{ 1.081 1.105	{ 75.51 98.73				
Norfolk -	51	52	37.562	{ 7.83 4.73	{ 1.0325 1.0167	{ 29 13.44	1144.13	22.002	22.852	0.4481
Norfolk -	51	50	37.562	{ 8.79 4.87	{ 1.071 1.036	{ 65.93 32.6				
Norfolk -	51	50	37.562	{ 8.30 10.527	{ 1.004 1.104	{ 3.44 97.5	1111.03	22.221	23.078	0.4525
Kent -	49.945	76	36.875	{ 8.125 4.013	{ 1.043 1.012	{ 40 9.37				
Average	50.680							21.849	23.117	0.4561

BREWING.

Brewing.

Brewing.

GRAIN. 2d Quality.	Weight per Bushel. lbs.	Bushels of Malt used.	Weight of Malt per Bushel. lbs.	Wort in Barrels.	Specific Gravity of Worts.	Lbs. per Bar- rel of Dry Extract.	Total Quantity of Dry Ex- tract.	Solid Ex- tract from a Bushel Malt in lbs. A- voirdupois.	Solid Ex- tract from a Bushel of Raw Grain.	Solid Ex- tract from 1 lb. Raw Grain.
SCOTCH.										
Haddington	52.265	72	37.298	{ 11.978	1.111	104	1560.06	21.667	22.359	0.4278
Haddington	52.265	60	37.298	{ 13.000	1.032	28.25				
Haddington & Berwick	50.531	60	38.501	{ 15	1.088	81.88	1435.15	23.920	24.146	0.4778
Haddington & Berwick				{ 4.75	1.0125	10				
Haddington & Berwick	50.531	64	38.501	{ 10.55	1.107	100.6	1376.55	21.510	21.831	0.4320
Haddington & Berwick				{ 8.22	1.090	26.87				
Fife	48.508	72	40.056	{ 0.722	1.017	14.6	1770.96	24.600	23.137	0.4770
Fife				{ 11.429	1.111	193.75				
Average			38.327	{ 7.25	1.054	50.62		22.739	22.834	0.4498
				{ 7.25	1.0078	6.25				
Bigs.										
Kirkcudbright	46.875	60	36.40	15.621	1.082	76.4	1210.62	20.177	20.428	0.4358
Kirkcudbright	46.875	72	36.40	{ 9.934	1.109	102	1441.37	20.019	20.268	0.4324
Kirkcudbright				{ 9.611	1.047	43.25				
Ayr	47.937	50	37.83	{ 13.388	1.075	70	1062.66	21.253	21.483	0.4481
Ayr				{ 4.138	1.011	9.37				
Ayr	47.937	98	37.83	{ 14.5	1.105	98.44	2111.22	21.543	21.560	0.4497
Ayr				{ 10.694	1.041	37.5				
Angus	47.392	72	38.57	{ 11.111	1.1028	95.9	1565.06	21.737	20.552	0.4337
Angus				{ 7.277	1.006	5				
Average	47.403		37.40	{ 10.083	1.006	5		20.946	20.858	0.4399
3d Quality. ENGLISH.										
Norfolk	51.937	72	36.683	{ 10.262	1.107	100	1587.24	22.045	23.457	0.4516
Norfolk				{ 14.528	1.040	36.5				
Norfolk	51.937	72	36.683	{ 10.484	1.104	97.25	1519.95	21.11	22.463	0.4325
Norfolk				{ 11.722	1.043	39.25				
Norfolk	51.625	76	37.61	{ 2.986	1.012	9.75	1676.85	22.064	23.056	0.4570
Norfolk				{ 14.33	1.094	87.5				
Norfolk	51.625	76	37.61	{ 7.61	1.035	23.75	1732.36	22.794	23.820	0.4614
Norfolk				{ 14.333	1.092	86.25				
Essex	47.638	70	35.125	{ 6.25	1.0477	44	1536.88	21.955	23.236	0.4799
Essex				{ 11.717	1.111	104				
Essex	48.000	72	35.656	{ 12.118	1.028	24.3	1540.3	21.393	21.848	0.4551
Essex				{ 2.085	1.010	8				
Average	50.459		36.561	{ 11.472	1.099	92.5		21.893	22.980	0.4562
				{ 7.805	1.036	32.8				
				{ 10.083	1.507	5.9				
SCOTCH.										
Haddington	48.969	72	36.816	{ 10.123	1.103	96.4	1390.45	19.311	19.617	0.4006
Haddington				{ 8.028	1.047	43.25				
Haddington	48.969	72	36.816	{ 3.441	1.021	17.4	1647.03	23.014	23.378	0.4774
Haddington				{ 10.012	1.112	105				
Haddington	48.854	72	37.312	{ 8.916	1.071	66	1490.51	20.602	20.233	0.4141
Haddington				{ 0.995	1.011	9				
Berwick	48.854	72	37.312	{ 14.000	1.086	80	1490.51	20.602	20.233	0.4141
Berwick				{ 5.916	1.039	35.3				
Average	48.930		36.98	{ 4.75	1.0088	6.9		20.976	21.076	0.4307

Brewing.

Brewing.

GRAIN. 3d Quality.	Weight per Bushel. lbs.	Bushels of Malt used.	Weight of Malt per Bushel. lbs.	Wort in Barrels.	Specific Gravity of Wort.	Lbs. per Bar- rel of Dry Extract.	Total Quantity of Dry Ex- tract.	Solid Ex- tract from a Bushel Malt in lbs. A- voirdupois.	Solid Ex- tract from Bushel of Raw Grain.	Solid Ex- tract from 1 lb. Raw Grain.
<i>Bigs.</i>										
Kirkcudbright	44.722	67.75	35.031	13.083 6.25	1.1067	99.68	1481.78	21.871	20.688	0.4621
					1.037	33.48				
Kirkcudbright	44.722	68	35.031	8.472 13.048 5.125 10.083	1.0047	3.75	1306.86	19.219	18.161	0.4061
					1.0865	80.625				
					1.004	3.12				
Average	44.722		35.031					20.545	19.414	0.4341

CHAP. V.

Of Ale and Beer.

Difference
between
Beer and
Ale.

The English word *ale* is obviously the same with the Swedish word *öl*, which is applied to the same kind of fermented liquor; while the word *beer* is synonymous with the German word *bier*. These two words in Great Britain are applied to two liquors obtained by fermentation from the malt of barley; but they differ from each other in several particulars. Ale is light-coloured, brisk, and sweetish, or, at least, free from bitter; while beer is dark-coloured, bitter, and much less brisk. What is called *porter* in England, is a species of beer, and the term *porter* at present signifies what was formerly called *strong beer*. The original difference between these two liquids was owing to the malt from which they were prepared. Ale malt was dried at a very low heat, and consequently was of a pale colour; while beer or porter malt was dried at a higher temperature, and had, of consequence, acquired a brown colour. This incipient charring had developed a peculiar and agreeable bitter taste, which was communicated to the beer, along with the dark colour. This bitter taste rendered beer more agreeable to the palate, and less injurious to the constitution than ale. It was consequently manufactured in greater quantities, and soon became the common drink of the lower ranks in England. When malt became high priced in consequence of the heavy taxes laid upon it, and the great increase in the price of barley which took place during the war of the French Revolution, the brewers found out, that a greater quantity of wort of a given strength could be prepared from pale malt than from brown malt. The consequence was, that pale malt was substituted for brown malt in the brewing of porter and beer. We do not mean that the whole malt employed was pale; but a considerable proportion of it. The wort, of course, was much paler than before, and it wanted that agreeable bitter flavour which characterized porter, and made it so much relished by most palates. The porter brewers endeavoured to remedy these defects by several artificial additions. They prepared an artificial colouring matter, by heating a solution of coarse sugar in an iron boiler till it became black, and was reduced to the consistency of treacle. The

Porter.

smoke issuing from it was then set on fire, and the whole was allowed to burn for about ten minutes, when the flame was extinguished by putting a lid on the vessel. This substance was mixed with a certain quantity of water, before it was cold. The porter is coloured by adding about two pounds of this colouring matter for every barrel of wort while in the gyle-tun. Some brewers make their colouring matter with infusion of malt instead of sugar; and, in 1809, M. de Roche took out a patent for preparing the colouring matter from the husks of malt, by burning them like coffee, and then infusing them in water. We believe that all these colouring matters are of the same nature. Of course, the brewer ought to employ that one of them which is cheapest.

To supply the place of the agreeable bitter which was communicated to porter by the use of brown malt, various substitutes were tried. Quassia, cocculus indicus, and, we believe, even opium were employed in succession; but none of them were found to answer the purpose sufficiently. Whether the use of these substances be still persevered in, we do not know, but we rather believe that they are not, at least by the London porter-brewers.

It was this change in the use of the malt; which occasioned the great falling off in the London porter, which has been so much complained of, and ascribed to so many causes. We do not believe that the schemes of Mr Jackson, of notorious memory, though they enriched himself, produced the injurious effects upon the London breweries that have been ascribed to them. This man, whose character was notorious, kept an apothecary's shop on Tower Hill, and, speculating on the means of amassing a speedy fortune, he hit upon the idea of brewing beer from various drugs instead of malt and hops. But instead of commencing practical brewer himself, he struck out the more profitable trade of teaching his process to the London brewers. Mrs Piozzi informs us, that, even from one great brewer, he contrived to realize an ample fortune. His methods must have been practised upon a considerable scale for some time; but we have no doubt that they have been all abandoned long ago. It was the French war, and the enormous tax upon malt, that was the real cause of the deterioration of the quality of London porter. Nor will it ever recover its former good qualities, till the tax on malt is re-

Brewing. reduced to its former rate; or, unless the price of porter be greatly enhanced, which is not likely to happen. We have sometimes thought, that, if quassia were reduced to powder, and burnt like coffee, it might probably be employed, with great advantage, both as a colouring matter of porter, and as likely to furnish the agreeable bitter, at present considered as peculiar to brown malt.

The quantity of malt employed annually in Great Britain in brewing ale and beer, may be easily deduced from the annual statements of the amount of the malt tax, printed by order of the House of Commons.

Malt employed annually in Great Britain.

In the year 1813, the gross produce of the malt tax for England, was L. 4,188,450, 6s. 9d. Now, as this duty is levied at the rate of four shillings and fourpence per bushel, it follows, that the quantity of malt made in England, and charged with duty, amounted to 2,416,884.81 quarters. If we admit, that the quantity of malt actually made, exceeds, by 5 per cent. what is charged with duty, in that case, the whole malt actually made in England during the year 1813, was 2,537,204 quarters.

In Scotland the actual receipts during the year 1813, were L. 134,106, 12s. 0½d. This, at the rate of three shillings and eightpence and half a farthing per bushel, which is the rate of the duty for Scotland, makes the amount of the quarters of malt made in that kingdom during the year 1813, to be 91,486.32. We cannot here make the allowance of 5 per cent. for the increase of bulk from malting; because we do not know what portion of this malt was made from English and what from Scotch barley. But as the duty in the Highlands of Scotland is lower than in the Lowlands, and, as it cannot be doubted, that a very considerable proportion of the barley malted in Scotland is the growth of England, perhaps we shall not err very far if we reckon the whole of the malt actually made in Scotland in 1813, at 100,000 quarters, which is only one twenty-sixth part of the whole malt made in Great Britain. Hence it follows, that four times as much beer is consumed in England as in Scotland, in proportion to the population of the two countries. This is a prodigious advantage in favour of Scotland; for there cannot be a doubt, that beer is inferior in salubrity to plain water as a beverage, and that, if

Brewing. the money spent by the common people in England on beer, were employed to buy food, they would be much more healthy, stout, and happy than they are at present.

In the year 1814, the gross receipts of the malt tax in England amounted to L. 4,772,332, 5s. 5½d. This, at the rate of four shillings and fourpence per bushel, indicates 2,753,268.6 quarters of malt; and, making an allowance of 5 per cent., it follows, that the whole malt made in England in 1814, amounted to 2,890,932 quarters.

In Scotland, during the same year, the gross receipts on the malt duty amounted to L. 125,787, 7s. 10½d., which, at the rate of three shillings and eightpence one-eighth per bushel, indicates 85,521.18 quarters of malt. We may increase this on account of the increase of malt not reckoned in the tax, and on account of the tax in the Highlands being lower than in the Lowlands, to 90,000 quarters of malt, which is a tenth less than the quantity malted in 1813, while, in England, the quantity malted had increased considerably. Thus, it appears, that the whole quantity of malt made in Great Britain during the year 1814, was 2,980,932 quarters.

Malt made in 1813, in quarters,	2,637,204
Ditto in 1814,	2,980,932
Mean,	2,809,068

But this consumption of barley, enormous as it is, by no means gives us the whole of that grain consumed annually in Great Britain in the manufacture of spiritous liquors. For the distillers employ at least two-thirds of the barley which they use in the state of raw grain. Now, this quantity does not pay any malt tax, and, of course, is not included in the preceding estimate. It might be possible to form an idea of this quantity from the duty levied upon spirits; but such an inquiry would be foreign to the subject of this article.

But perhaps the following Table, exhibiting the quantity of porter brewed by the thirteen principal houses in London, during each of the last nine years, will give the reader a more accurate conception of the extent to which this trade is carried in this country.*

* There are many other porter-brewers in London besides those whose names are contained in this Table. The following were the seven next in order to those given in the Table for 1812, with the quantity of porter manufactured by each:

Martineau and Co. - - -	24,148 barrels.	Tickels - - -	18,071 barrels.
Hodgson - - -	24,143	Dickinson - - -	16,292
Pryors - - -	20,210	Green and Co. - - -	14,090
Starkey - - -	18,136		

If we were to give an opinion respecting the different modes followed in the different houses, we would place Martineau at the head of the trade in point of accuracy and skill.

The following Table exhibits the quantity of strong ale brewed by the seven principal houses in London, in the year ending the 5th of July 1815:

Stretton and Co. - - -	27,094 barrels.	Hale and Co. - - -	10,134 barrels.
Wyatt - - -	22,146	Ball and Co. - - -	7,985
Charrington and Co. - - -	20,444	Thorpe and Co. - - -	5,433
Goding and Co. - - -	14,491		

Brewing.

Brewing.

Quantity Brewed in One Year, ending	July 1807.	July 1808.	July 1809.	July 1810.	July 1811.	July 1812.	July 1813.	July 1814.	July 1815.
BY	Barrels.	Barrels.	Barrels.	Barrels.	Barrels.	Barrels.	Barrels.	Barrels.	Barrels.
Barclay & Perkins	166,600	184,196	205,328	235,053	264,405	270,259	257,265	262,467	337,621
Meux, Reid, & Co.	170,879	190,169	150,105	211,009	220,094	188,078	165,153	165,628	182,104
Trueman, Hanbury, & Co.	135,972	117,374	130,846	144,990	142,179	160,164	140,114	145,141	172,162
F. Calvert & Co.	83,004	68,924	90,363	133,491	105,887	108,212	100,093	100,391	119,333
Whitbread & Co.	104,251	111,185	100,275	110,939	122,316	122,446	135,892	141,104	161,018
H. Meux & Co.			40,663	93,660	103,152	102,493	82,012	100,776	123,100
Combe	82,273	70,561	75,551	85,150	81,761	100,824	97,035	95,398	105,081
Brown, Parry, & Co.*	125,654	131,647	114,001	84,475	72,367	51,274	45,500	30,162	38,107
Goodwynne, Skinner, & Co.	72,580	70,232	60,233	74,233	85,181	81,022	71,467	62,019	72,080
J. Calvert †	37,033	38,002	39,155			28,038		30,252	32,256
Elliot & Cq.	47,388	48,669	45,608	57,251	58,042	58,035	49,269	45,162	56,922
Taylor	30,273	32,800	40,907	44,510	46,222	51,220	41,850	42,126	51,294
Clowes, Maddox, & Newbury	38,544	39,273	40,231	41,594	36,872	34,016	29,844		
Totals	1,092,451	1,103,032	1,132,366	1,316,345	1,338,478	1,356,085	1,215,494	1,220,616	1,451,688

To form a proper estimate of the quantity of porter contained in this Table, it is necessary to know that the London barrel contains 36 gallons.

The usual limits of the wort of strong ale in this country, may be stated at from 60 to 120 pounds *per* barrel, or from the specific gravity 1.064 to 1.11275 at the temperature of 60°. The highest priced ales are not always the strongest; as the price depends in a great measure on the reputation of the brewer. The fermentation of ale is not carried far; the consequence is, that a considerable portion of the saccharine matter still remains in the liquid, apparently unaltered. By means of the infusion of nut-galls, too, traces of starch may be still detected in strong ale even after it has been kept for some time in bottles. The annexed Table exhibits the original strength of the wort before the fermentation began, and likewise the diminution of specific gravity produced by the fermentation, or the *attenuation*, as this diminution is termed by brewers and distillers.

As a certain quantity of alcohol is evolved in the ale by the fermentation, it is obvious that the last column is not quite accurate. The real quantity of saccharine matter in each of these also must be greater than what is indicated in that column, because the effect of the saccharine matter, in increasing the specific gravity of the ale, is counteracted by the alcohol, which tends to diminish that specific gravity. By casting the eye over the preceding Table, it will be seen that the attenuation does not follow the ratio of the strength. It was greatest of all in the third, and least in the first brewing. These brewings being the same with those given in the fourth chapter, in order to illustrate the quantity of yeast used in fermenting, the reader, by comparing the two Tables together, will be able to form some

Original specific gravity of the Wort.	lbs. per barrel of saccharine matter in it.	Specific gravity of the Ale.	lbs. per barrel of saccharine matter in it.	Attenuation or proportion of saccharine matter decomposed.
1.095	88.75	1.050	46.25	0.478
1.0918	85.62	1.042	38.42	0.552
1.0829	78.125	1.0205	16.87	0.787
1.08625	80.625	1.0236	20.00	0.757
1.078	73.75	1.028	24.25	0.698
1.070	65.00	1.0285	25.00	0.615
1.10025	93.75	1.040	36.25	0.613
1.1025	95.93	1.042	38.42	0.6
1.0978	91.56	1.03075	27.00	0.705
1.0956	89.37	1.0358	32.19	0.640
1.113	105.82	1.0352	31.87	0.661
1.1092	102.187	1.0302	26.75	0.605
1.1171	110.0	1.040	36.25	0.669
1.103	96.4	1.0271	23.42	0.757
1.066	61.25	1.0214	17.8	0.709

* During the last four years in the table, we have substituted Cox and Campbell.

† During the last four years, we have substituted Hollingsworth and Company.

Brewing. conclusions respecting the effect of different quantities of yeast, and different temperatures upon the attenuation of strong ale.

Strength of Porter. Porter is much weaker than strong ale. The average specific gravity of porter-wort, according to Shannon (as deduced from his strength by the *saccharometer*), is 1.0645, which indicates 60 pounds *per barrel* of saccharine extract. Hence the reason why it is so much less glutinous and adhesive than strong ale. The fermentation which porter undergoes is, we believe, much less than that of ale. But we have no very accurate information on the subject. According to the experiments of Mr Brande, brown stout, which is the strongest porter made in London, contains 6.8 *per cent.* by measure, of alcohol of the specific gravity 0.825. If he had given us the specific gravity of this porter before distillation, it would have enabled us to determine in some measure the error in the attenuation, as indicated by the *saccharometer*.

The porter-brewers in London use three kinds of malt; namely, pale malt, amber malt, and brown malt. These three are mashed separately, and the worts from each are afterwards mixed together in the same fermenting vessel. In some breweries, as in that of Barclay and Perkins in the Borough, there are three separate mash-tuns. In other breweries, the custom is to mash one kind of malt the first day, another kind the second day, and a third kind the

third day. The first day's wort is put into the fermenting vessel, and mixed with yeast; and the other two worts are added to it successively as they are formed. Hence it is very difficult to determine with accuracy the strength of the worts in the London breweries. It could only be done by knowing the quantity of wort from each malt, and its specific gravity when let into the fermenting vessel. We have had an opportunity of determining the strength of the porter wort in all the principal breweries in London. The average specific gravity of brown-stout wort is 1.0624. The wort of the best common porter is of the specific gravity 1.0535; that of the worts or weakest is as low as 1.0374. The average specific gravity deduced from 20 brewings was 1.0500. Such wort contains about 46.4 lbs. *per barrel* of saccharine matter. Judging from the taste of some of the worts, quassia seems to be employed in considerable quantity by some of the brewers, and much more sparingly, if at all, by others. The fermentation of porter is carried on with considerable rapidity, so that it is over in two or three days. The specific gravity of the porter is usually brought down to 1.013 or 1.017. The specific gravity of the best brown-stout, after standing some months in the bottle, is 1.0106. The proportion of pale and brown malt used in the different houses varies. One of the best brewers in London uses nearly 2 parts pale malt to 1 part brown. (J.)

EXPLANATION OF THE PLATES.

Figs. 1. and 2., Plate XL., explain the arrangement of the Utensils and Machinery in a Porter-Brewery on the largest scale; in which, however, it must be observed, that the elevation fig. 1. is, in a great degree, imaginary, as to the plane upon which it is taken; but the different vessels are arranged so as to explain their uses most readily, and, at the same time, to preserve, as nearly as possible, the relative positions which are usually assigned to each, in works of this nature.

The malt for the service of the brewery is stored in vast granaries or malt-lofts, usually situated in the upper part of the buildings. Of these, we have only been able to represent one at A, fig. 1.; the others, which are supposed to be on each side of it, cannot be seen in this view. Immediately beneath the granary A, is the mill, in the upper floor of which are two pair of rollers, for bruising or crushing the grains of the malt. (An enlarged representation of the rollers is given at figs. 3. and 4.) In the floor beneath the rollers are the mill-stones *bb*, where the malt is sometimes ground, instead of the simple bruising which it receives by passing between the rollers.

The malt, when prepared, is conveyed by a trough into a chest *d*, from which it can be elevated by the action of a spiral screw *e* (see also figs. 5. and 6.), into the large chest or binn B, for ground malt, situated immediately over the mashing-tun D. The malt is reserved in the binn till wanted; and it is

then let down into the mashing-tun, where the extract is obtained by hot water supplied from the copper G.

The water, for the service of the brewery, is obtained from the well E, by a lifting pump worked by the steam-engine, and the forcing-pipe *f* of this pump, conveys the water up to the large reservoir or water-back F, placed at the top of the engine-house; from this cistern iron pipes are laid to the copper G, and also every part of the establishment where cold water can be wanted for cleaning and washing the vessels. The copper G can be filled with cold water by only turning a cock; and the water, when boiled therein, is conveyed by the pipe *g*, into the mashing-tun D; it is introduced beneath a false bottom, upon which the malt lies, and rising up through the holes in the false bottom, it extracts the saccharine matter from the malt; a greater or less time being allowed for the infusion, according to circumstances. The instant the water is drawn off from the copper, fresh water must be let into it, in order to be boiled ready for the second mashing; because the copper must not be left empty for a moment, otherwise the intense heat of the fire would melt the bottom. For the convenience of thus letting down, at once, as much liquor as will fill the bottom of the copper, a pan or second boiler is placed over the top of the copper, as seen in fig. 3. Plate XLI., and the steam rising from the copper, communicates a considerable degree of heat to the contents of the

Description of Plates. pan, without any expence of fuel. This will be more minutely explained hereafter.

During the process of mashing, the malt is agitated in the mash-tun to expose every part to the action of the water. This is done by a machine contained within the mash-tun, and put in motion by the horizontal shaft H, leading from the mill. The mashing-machine is shown in fig. 1. Plate XLI. When the mashing is finished, the wort, or extract, is drained down from the malt, into a vessel I, of similar dimensions to the mash-tun, and situated immediately beneath, from which it is called the under-back. Here the wort does not remain longer than is necessary to drain off the whole of it from the tun above. It is then pumped up by the three-barrelled pump *k*, into the pan at the top of the copper, by a pipe which cannot be seen in the Plate.

The wort remains in the copper pan until the water, for the succeeding mashes, is discharged from the copper. But this waiting is no loss of time, because the heat of the copper and the steam arising from it, makes the wort, which had become cooler, ready for boiling. The instant the copper is empty, the wort is let down from the pan into the copper, and the second wort is pumped up from the under-back into the copper pan. The proper proportion of hops is thrown into the copper through the near hole, and then the door is shut down, and screwed fast, to keep in the steam, and cause it to rise up through pipes into the pan; and by bubbling up, through the wort in the pan, it communicates so much heat, that it is soon ready for boiling in its turn; for it is to be observed, that the different worts follow each other, through all the different vessels, with the greatest regularity, so that there is no loss of time, but every part of the apparatus is constantly employed. When the boiling of the wort has continued a sufficient time to coagulate the grosser part of the extract and to evaporate part of the water, the contents of the copper are run off through a large cock into the jack-back K; which is a vessel of sufficient dimensions to contain it, and provided with a bottom of cast-iron plates, perforated with small holes, through which the wort drains and leaves the hops. The hot wort is drawn off from the jack-back through the pipe *h*, by the three-barrelled pump, which throws it up to the coolers L; this pump being made with different pipes and cocks of communication, to serve all the purposes of the brewery except that of raising the cold water from the well. The coolers L, are very shallow vessels, built over one another in several stages; and that part of the building in which they are contained, is built with open lattice-work on all sides, to admit the free current of air. When the wort is sufficiently cooled to be put to the first fermentation, it is conducted in pipes, from all the different coolers, to the large fermenting vessel or gyle-tun M, which, with another similar vessel behind it, is of sufficient capacity to contain all the beer of one day's brewings.

When the first fermentation is concluded, the beer is drawn off from the great fermenting vessels M, into the small fermenting casks, or cleansing vessels N, of which there are a great number in the

VOL. II. PART II.

brewery. They are placed four together, and to each four a common spout is provided to carry off the yeast and conduct it into the troughs *u*, placed beneath. In these cleansing vessels the beer remains till the fermentation is completed, and it is then put into the store-vats, which are casks or tuns of an immense size, where it is kept till wanted, and is then drawn off into barrels and sent away from the brewery. The store-vats are not represented in the Plate, but are of a conical figure and of different dimensions, from fifteen to forty feet diameter, and usually twenty feet in depth. The steam-engine which puts all the machinery in motion is explained by the figure. On the axis of the large fly-wheel, is a bevelled cog-wheel, which turns another similar wheel upon the end of an horizontal shaft, which extends from the engine-house to the great horse-wheel, which it turns by means of a cog-wheel. The horse-wheel puts in motion all the pinions for the mill-stones *bb*, and also the horizontal axis which works the three-barrelled pump *k*. The rollers *aa* are turned by a bevelled wheel upon the upper end of the axis of the horse-wheel, which is continued for that purpose; and the horizontal shaft H, for the mashing-engine, is driven by a pair of bevelled wheels. There is likewise a sack-tackle, which is not represented. It is a machine for drawing up the sacks of malt from the court-yard to the highest part of the building, whence the sacks are wheeled on a truck to the malt-loft A, and the contents of the sacks are thrown in.

The horse-wheel is intended to put in horses occasionally, if the steam-engine should fail; but these engines are now brought to such perfection that it is very seldom any accidents occur with them.

Fig. 2. Plate XL. is a representation of the fermenting-house at the brewery of Messrs. Whitbread and Co. Chiswell Street, London, which is by far the most complete in its arrangement of any work of the kind, and was erected after the plan of Mr Richardson, who conducts the brewing at those works. The whole of fig. 2. is to be considered as devoted to the same object as the large vessel M, and the casks N, fig. 1. In fig. 2. *r* is the pipe which leads from the different coolers to convey the wort to the great fermenting vessels or squares M, of which there are two, one behind the other; *ff* represents a part of the great pipe which conveys all the water from the well E, fig. 1. up to the water cistern P. This pipe is conducted purposely up the wall of the fermenting-house, fig. 2., and has a cock in it, near *r*, to stop the passage. Just beneath this passage a branch-pipe *p*, proceeds and enters a large pipe *xx*, which has the former pipe *r*, withinside of it. From the end of the pipe *x*, nearest to the squares M, another branch *ns* proceeds, and returns to the original pipe *f*, with a cock to regulate it. The object of this arrangement is to make all, or any part of, the cold water flow through the pipe *xx*, so as to surround the wort-pipe *r*, which is only made of thin copper, and lower the temperature of the wort passing through the pipe *r*, until, by the thermometer, it is found to have the exact temperature which is desirable, before it is put to ferment in the great square M. By means of the cocks at *n* and *p*, the quantity of cold water,

3 Q

Description
of Plates.

which shall pass in contact with the surface of the pipe *r*, can be regulated at pleasure, so as to have a command of the heat of the wort when it enters into the square.

When the first fermentation in the squares *M* is finished, the beer is drawn off from them by pipes marked *v*, and conducted by its branches *w* to the different rows of fermenting tuns marked *NN*, which fill all the building. Between every two rows are placed large troughs, to contain the yeast which they throw off. The Plate shows that the small tuns are all placed on a lower level than the bottom of the great vessels *M*, so that the beer will flow into them, and, by standing in them all, will fill them to the same level. When they are filled, the communication-cock is shut; but, as the working off of the yeast diminishes the quantity of beer in each vessel, it is necessary to fill them up again. For this purpose, the two large vats *OO* are filled from the great vessels *M*, before any beer is drawn off into the small casks *N*, and this quantity of beer is reserved at the higher level for filling up. The two vessels *OO* are, in reality, placed between the two squares *M*, but we have been obliged to place them so that they can be seen. Near each filling-up tun *o* is a cistern *t*, with a pipe of communication from the tun *O*, and this pipe is closed by a float-valve. The small cisterns *t* have always a communication with the pipes, which lead to the small fermenting vessels *N*; and therefore the surface of the beer in all the tuns and in the cisterns will always be at the same level; and as this level subsides by the working off of the yeast from the tuns, the float sinks, and opens the valve, so as to admit a sufficiency of beer from the filling up tuns *o*, to restore the surfaces of the beer in all the tuns, and also in the cistern *t* to the original level. In order to carry off the yeast which is produced by the fermentation of the beer in the tuns *OO*, an iron dish or vessel is made to float upon the surface of the beer which they contain; and from the centre of this dish a pipe *o* descends, and passes through the bottom of the tun, being filled through a collar of leather, so as to be tight, at the same time that it is at liberty to slide down as the surface of the beer descends in the tun. The yeast flows over the edge of this dish, and is conveyed down the pipe to a trough beneath.

Beneath the fermenting house are large arched vaults *P*, built of stone, and lined with stucco. Into these the beer is let down when sufficiently fermented, and is kept till wanted. These vaults are used at Mr Whitbread's brewery instead of the great store vats of which we have before spoken, and are in some respects preferable, because they preserve a great equality of temperature, being beneath the surface of the earth.

Figs. 3. and 4. Plate *XL*. represent the malt-rollers, or machine for bruising the grains of malt. *A* is the hopper, into which the malt is let down from the malt-loft above; and from this the malt is let out gradually through a sluice or sliding-shuttle *a*, and falls between the rollers *BD*. These rollers are made of iron, truly cylindrical, and their pivots are received in pieces of brass let into iron frames, which are bolted down to the wooden frame of the machine.

A screw, *E*, is lapped through the end of each of these iron frames; and by these screws the brasses can be forced forwards, and the rollers made to work closer to each other, so as to bruise the malt in a greater degree. *G* is the shaft by which one of the rollers is turned; and the other receives its motion by means of a pair of equal cog-wheels *H*, which are fixed upon the ends of the pivots, at the opposite ends of each of the rollers: *d* is a small lever, which bears upon the teeth of one of these cog-wheels, and is thereby lifted up every time a cog passes. This lever is fixed on the extremity of an axis, which passes across the wood frame; and in the middle of it has a lever *c*, fig. 3. bearing up a trough *b*, which hangs under the opening of the hopper *A*. By this means the trough *b* is constantly jogged, and shakes down the malt regularly from the hopper *A*, and lets it fall between the rollers: *e* is a scraper of iron plate, which is always made to bear against the surface of the roller by a weight, to remove the grains which adhere to the roller.

Fig. 5. is the screw by which the ground or bruised malt is raised up, or conveyed from one part of the brewery to another. *K* is an inclined bar or trough, in the centre of which the axis of the screw *H* is placed, and the spiral iron plate or worm, which is fixed projecting from the axis, and which forms the screw, is made very nearly to fill the lower part of the inside of the box. By this means, when the screw is turned round by the wheels *FF*, or by any other means, it raises up the malt from the box *d*, and delivers it at the spout *G*.

The screw is equally applicable for conveying the malt horizontally in the trough *k* as inclined; and similar machines are employed in various parts of breweries for conveying the malt wherever the situation of the works require.

Fig. 1. Plate *XLI*. is the mashing-machine. *WW* is the tun, made of wood staves, hooped together. In the centre of it rises a perpendicular shaft *NN*, which is turned slowly round by means of the bevelled wheels *KI* at the top. *RR* are two arms projecting from the axis, and supporting the short vertical axis *S* at the extremities, so that, when the central axis is turned round, it will carry the axle *S* round the tun in a circle. The axis *S* is furnished with a number of arms *T*, which are shown in fig. 2, and have blades placed obliquely to the plane of their motion. When the axis is turned round, these arms agitate the malt in the tun, and give it a constant tendency to rise upwards from the bottom.

The motion of the axis *S* is produced by a wheel *Q* on the upper end of it, which is turned by a wheel *P*, fastened on the lower end of the tube *O*, which turns freely round upon the central axis *N*. On the upper end of the same tube *O* is a bevelled wheel *M*, receiving motion from a wheel *L*, which is fixed upon the end of the horizontal axis *F*, which gives motion to the whole machine. This same axis has a pinion *G* upon it, which gives motion to the wheel *H*, fixed upon the end of an horizontal axle, which, at the opposite end, has a bevelled pinion *I*, working the wheel *K*, before mentioned. By this means the rotation of the central axis *N* will be very slow, compared with the motion of the axis *S*; for the latter

Description of Plates. will make 17 or 18 revolutions on its own axis in the same space of time that it will be carried once round the tun by the motion of the axis N. At the beginning of the operation of mashing, the machine is made to move with a slow motion; but, after having wotted all the malt by one revolution, it is made to revolve quicker. For this purpose the ascending shaft A, which gives motion to the machine, has two bevelled wheels BC fixed upon a tube X, which is fitted upon the shaft. These wheels actuate the wheels D and E upon the end of the horizontal shaft F; but the distance between the two wheels B and C is such, that they cannot be engaged both at once with the wheels D and E; but the tube X, to which they are fixed, is capable of sliding up and down on the axis A sufficiently to bring either wheel B or C into action with its corresponding wheel E or D upon the horizontal shaft: and as the diameters of BE and CD are of very different proportions, the velocity of the motion of the machine can be varied at pleasure, by using one or other: *b* and *c* are two levers, which are forked at the ends, and embrace collars at the ends of the tube X; and the levers being united by a rod; the handle *b* gives the means of moving the tube X and its wheels BC up or down, to obtain the action of the different wheels.

Figs. 3. and 4. represent a large close copper. AA is the copper, and B the pan placed over it. The copper has a large tube E rising up from the dome of it, to convey the steam; and from the top of this, four inclined pipes R descend, the ends being immersed beneath the surface of the water or wort contained in the pan. By this means the steam which rises from the copper issues from the ends of the pipes R, and rises in bubbles through the liquor in the pan, so as to heat it. In the centre of the copper is a perpendicular spindle *a*, which, at the lower end, has arms *dd* fixed projecting from it, and is turned round by a cog-wheel *b* at the upper end. From the arms *dd*, chains are hung in loops, which drag round upon the bottom of the copper, when the axis is turned; and this motion stirs up the hops, to keep them from burning to the bottom: *fg* is a chain and roller to draw up the spindle *a*, when the rowser is not wanted; and *ee* are iron braces proceeding from the outside of the copper, to retain the axis *a* firmly in the centre of the copper. D is the waste-pipe for carrying off the steam into the chimney, when it is not required to heat the liquor in the pan. The copper represented in the drawing is made in the same manner as usual; but the fire is applied beneath it in a manner very different from the common brewing-coppers. The method was devised with a view to the burning or consuming the smoke: and was employed in the brewery of Messrs Meux and Company, London, about the year 1803.

The fire place is divided into two by a wall extended beneath the bottom of the boiler, as shown by Z in the plan, fig. 4. where the dotted circle A represents the bottom of the copper, and the circle X its largest part. The section in fig. 3. shows only one of these fire-places, of which C is the fire-grate; the raw coal is not thrown in through the fire door in the manner of common furnaces, but is

Description of Plates. put into a narrow inclined box of cast-iron *h*, built in the brick-work, and shaped like a hopper; the coals contained in this hopper fill it up, and stop the entrance of the air so as to answer the purpose of a door; and the coals at the lowest part or mouth of the hopper, are brought into a state of ignition before they are forced forwards into the furnace, which is done by introducing a rake or poker at *i*, just beneath the lower end of the hopper *h*, and forcing the coals forwards upon the grate bars C. Immediately over the hopper *h*, a narrow passage is left to admit a stream of fresh air along the top of the hopper to pass over the surface of the fuel, which is burning at the lower end of the hopper *h*. By this means the smoke rising from that portion of fuel, is carried forwards over the burning coals upon the grate C, and is thereby consumed. Beyond the grate bars *c*, a breast wall S is erected, to direct the flame upwards, against the bottom of the boiler A, and thence descending under the bottom, the flame is received into the flues, which make each a half turn round the lower part of the copper, as shown in the plan at *t t*, and then enter the chimney or perpendicular flue W at the same point; the entrance being regulated by a damper to make the draught more or less intense. There is also a sliding door or damper E, which closes up the lower part of the chimney, and by means of these two dampers the fire under the copper can be regulated to the greatest precision; for by opening the damper F it admits the cold air to enter immediately into the chimney, W, and thus take off the rapidity of the draught; and, at the same time, by closing the dampers from the flues into the chimney, the intensity of the draught through the fire is checked, which is very necessary to be done when the contents of the copper are drawn off. Immediately over the fire-grate *c*, an arch of fire-bricks or stone, *s*, is placed beneath the bottom of the copper, to defend it from the intense heat. The chimney is supported on iron columns RR. Behind the fire-grate *c*, is a cavity, *r*, for the reception of the masses of scorise which are always formed in so large a fire. They are pushed back off the grate into this receptacle with an iron hook, as fast as they accumulate. The bottom of this receptacle is formed of sliding iron doors, which can be opened by drawing them out, and in this way the clinkers are discharged; or the whole of the fire may be driven back off the grate into this cavity, and will then fall through into the ash-pit and be removed from the copper, which is very necessary to be done when the copper is to be cooled, so that men may descend into it to clean out the sediment which is left after boiling the wort. For a more particular description of this method of setting boilers, see *Philosophical Magazine*, Vol. XVII.

Fig. 6. represents one of the sluice-cocks which are used to make the communications of the pipes with the pumps or other parts of the brewery. BB represents the pipe in which the cock is placed. The two parts of this pipe are screwed to the sides of a box CC, in which a slider A rises and falls, and intercepts at pleasure the passage of the pipe. The slider is moved by the rod *a*, which passes through a stuffing-box in the top, the box which

contains the slider, and has the rack *b* fastened to it. The rack is moved by a pinion fixed upon the axis of a handle *e*, and the rack and pinion is contained in a frame *d*, which is supported by two pillars. The frame contains a small roller behind the rack, which bears it up towards the pinion, and keeps its teeth up to the teeth of the pinion. The slider *A* is made to fit accurately against the internal surface of the box *C*, and it is made to bear against this surface by the pressure of a spring, so as to make a perfectly close fitting.

Fig. 5. is a small cock to be placed in the side of the great store-vats, for the purpose of drawing off a small quantity of beer, to taste and try its quality. *A* is a part of the stave or thickness of the great store-vat; into this the tube *B* of the cock is fitted, and is held tight in its place by a nut *a* *d* screwed on withinside. At the other end of the tube *B*, a plug *c* is fitted, by grinding it into a cone, and it is kept in by a screw. This plug has a hole up the centre of it, and from this a hole proceeds sideways and corresponds with a hole made through the side of the tube when the cock is open; but when the plug *c* is turned round, the hole will not coincide, and then the cock will be shut. *D* is the handle or key of the cock, by which its plug is turned to open or shut it; this handle is put up the bore of the tube (the cover *E* being first unscrewed and removed), and the end of it is adapted to fit the end of the plug of the cock. The handle has a tube or passage bored up it to convey the beer away from the cock when it is open-

ed, and from this the passage *f*, through the handle, leads to draw the beer into a glass or tumbler. The hole in the side of the plug is so arranged, that when the handle is turned into a perpendicular direction with the passage *f* downwards, the cock will be open. The intention of this contrivance is, that there shall be no considerable projection beyond the surface of the tun; because it sometimes happens that a great hoop of the tun breaks, and falling down, its great weight would strike out any cock which had a projection; and if this happened in the night much beer might be lost before it was discovered. The cock above described being almost wholly withinside, and having scarcely any projection beyond the outside surface of the tun, is secure from this accident.

Fig. 7. is a small contrivance of a vent peg, to be screwed into the head of a common cask when the beer is to be drawn off from it, and it is necessary to admit some air to allow the beer to flow. *AA* represents a portion of the head of the cask into which the tube *B* is screwed. The top of this tube is surrounded by a small cup, from which project the two small handles *CC*, by which the peg is turned round to screw it into the cask. The cup round the upper part of the tube is filled with water, and into this a small cup *D* is inverted; in consequence, the air can gain admission into the cask when the pressure within is so far diminished that the air will bubble up through the water, and enter beneath the small cup *D*. (R.)

BRICK, a kind of artificial stone made of baked clay.

History.

1. The art of making bricks is so simple that it must have been practised in the earliest ages of the world; probably before mankind had discovered the method of fashioning stones to suit the purposes of building. The Book of Genesis informs us, that burnt-bricks were employed in the construction of Babel. Now, as this structure appears to have been raised about 400 years after the period of the flood, we may say, without much exaggeration, that the method of making bricks existed from the very origin of society. Bricks seem to have been in common use in Egypt while the Israelites were in subjection to that nation; for the task assigned them was the making of brick; and we are informed in Exodus, that the Israelites built two Egyptian cities. No particulars are given in scripture of the method of making bricks; but as straw was one of the ingredients, and as it very seldom rains in Egypt, it is probable that their bricks were not burnt, but merely baked by the heat of the sun. The same mode of making bricks seems still to be practised in the East. For the ruins of the tower near Bagdad, which some have considered as the Tower of Babel, others as the Tower in Babylon described by Herodotus (lib. i. c. 181.), is formed of unburnt-bricks. We have seen specimens from that place; they are large, but thin, and have a brown

colour. It is not at all likely that structures of unburnt-brick should be able to resist the weather since the time of Nebuchadnezzar; it is much more probable that the tower in question was raised by the Arabs in comparatively modern times.

The art of brick-making was carried to considerable perfection by the Greeks. Pliny informs us, that they made use of bricks of three different sizes, distinguished by the following names; *didoron*, or six inches long; *tetradoron*, or twelve inches long; and *pentadoron*, or fifteen inches long (lib. xxxv. c. 14). That the Romans excelled in the art of making bricks we have the amplest evidence, since brick structures raised at Rome 1700 years ago, Trajan's pillar for example, still remain as entire as when first built. Brick-making has been carried to great perfection by the Dutch, who have long been in the habit of forming their floors, and even of paving their streets, in some cases, with bricks. And it is remarkable how long their bricks will continue uninjured in such situations. Though brick-making has been long carried on in England, and especially in the neighbourhood of London, upon a very great scale, and though the process upon the whole is conducted in this country with very considerable skill, yet it must be acknowledged, that English bricks are by no means so durable as Dutch bricks. We are disposed to ascribe this inferiority not so much to the nature of the materials employed in the manu-

Fig. 1.

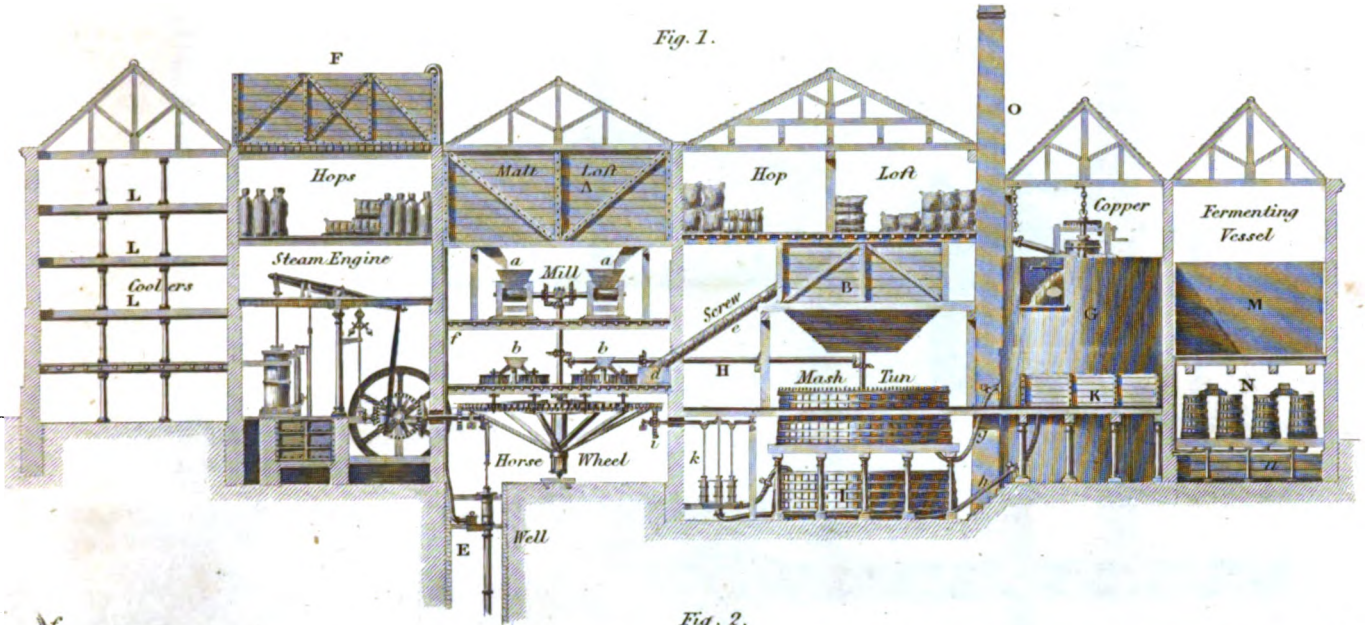

Fig. 2.

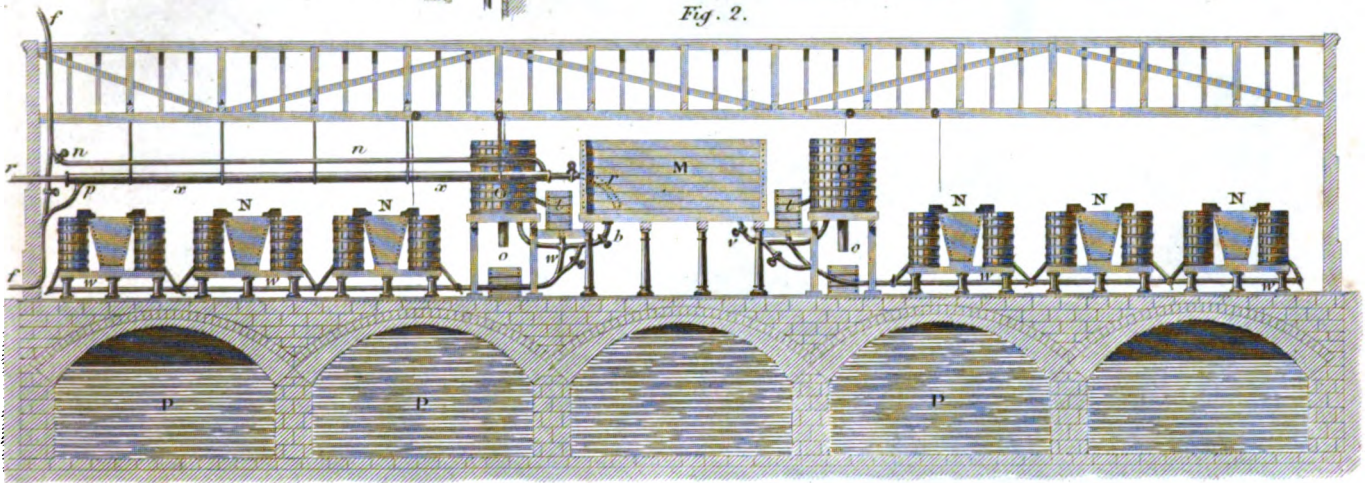

Fig. 7.

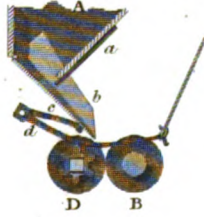

Fig. 5.

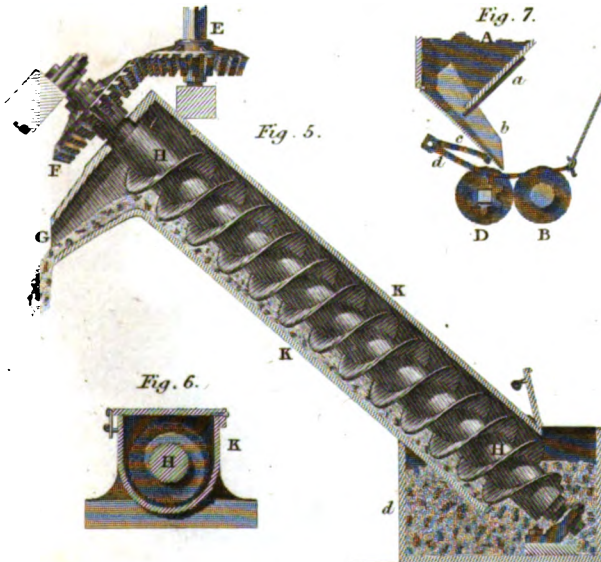
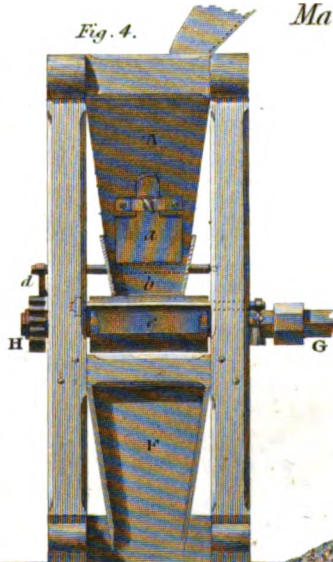

Fig. 6.

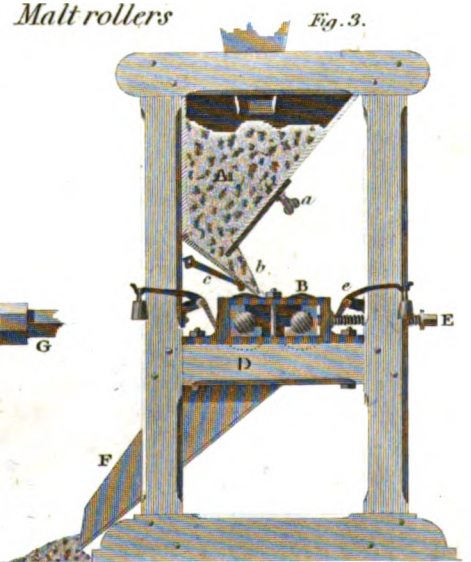

Fig. 4.



Malt rollers

Fig. 3.



Mashing Engine.

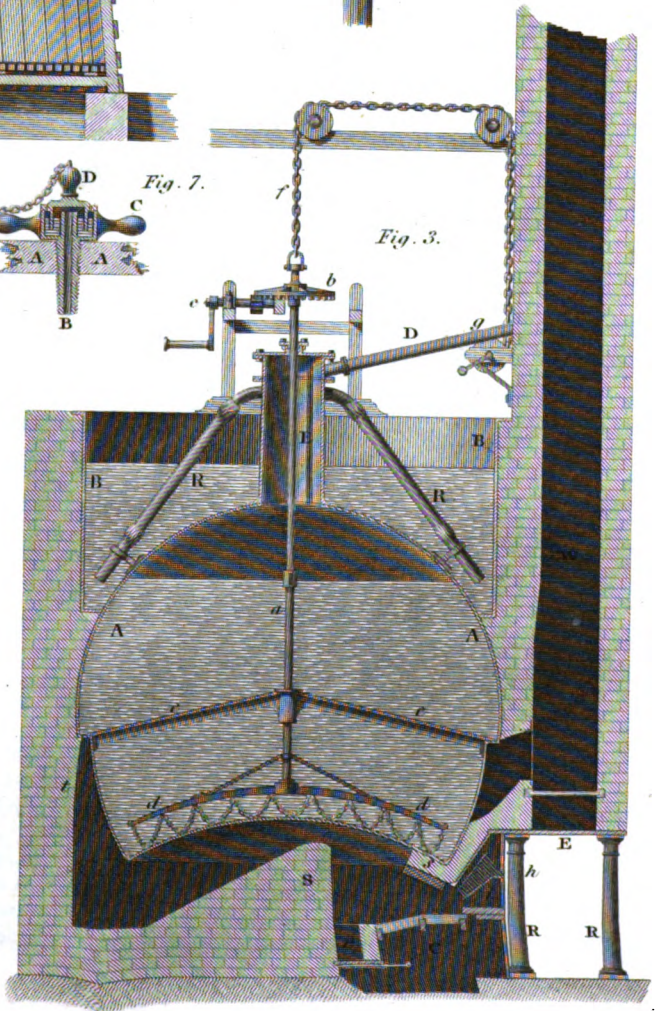
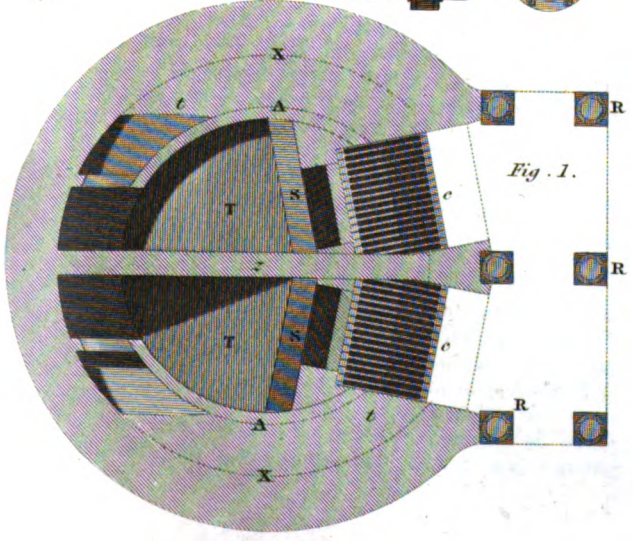
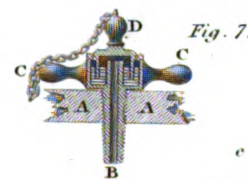
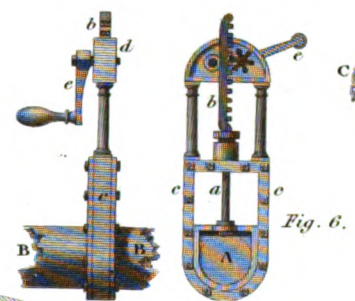
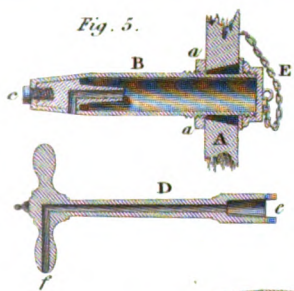
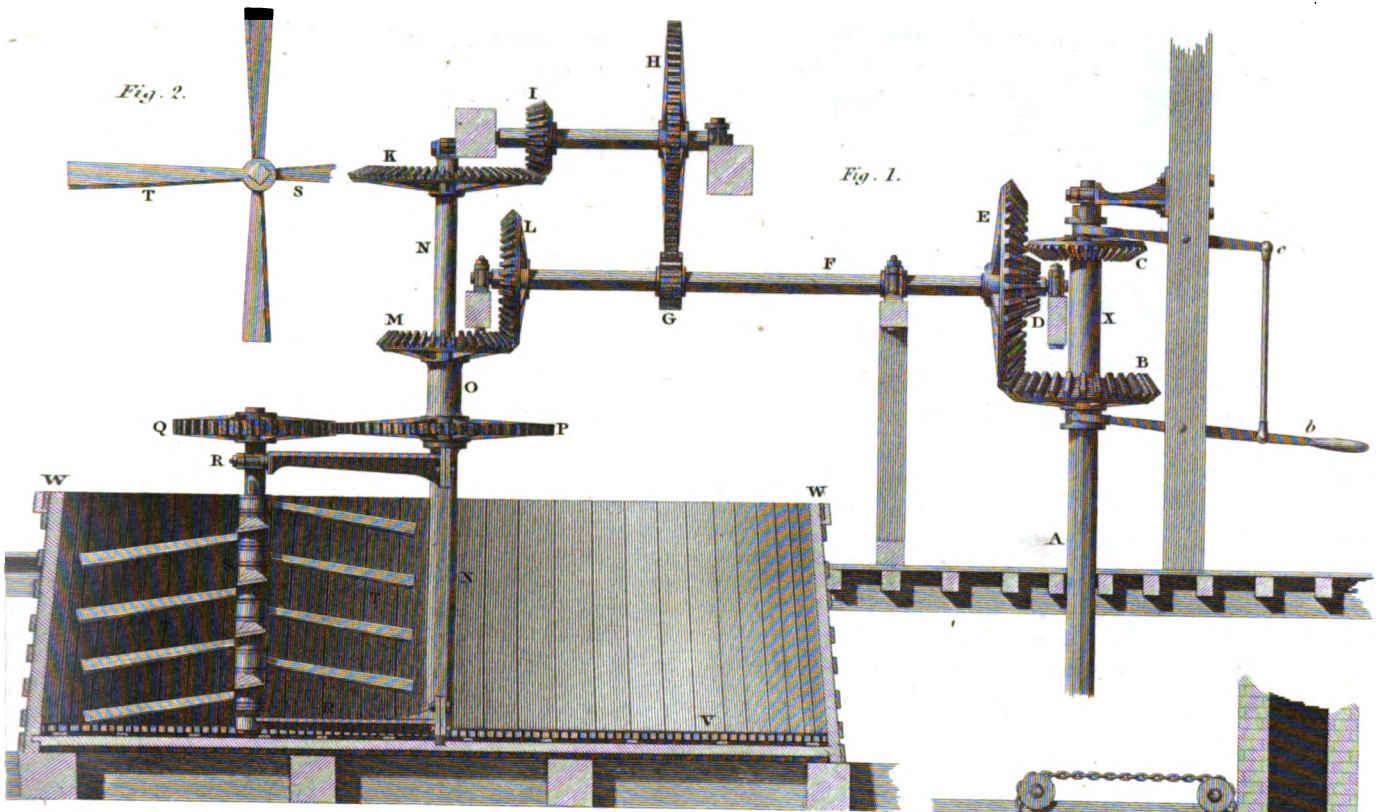

Brick. Manufacture of English bricks, as to the mode most frequently employed in London in building houses. Few of the London houses, comparatively speaking, are freeholds. Most of them are built upon ground let for a lease of a certain number of years, which seldom exceeds 99 years. After the expiration of this period, the house becomes the property of the landlord who let the ground. Thus it becomes the interest of the builder to construct the house so, that it shall last only as long as the lease. Hence the goodness of the bricks becomes only a secondary object. Their cheapness is the principal point. The object, therefore, of the brickmakers is not to furnish durable bricks, but to make them at as cheap a rate as possible. Accordingly, the saving of manual labour, and of fuel, have been carried by the makers of London bricks to very great lengths. We cannot but consider this mode of proceeding as very objectionable, and as entailing a much heavier expence upon London than would have been incurred had twice the original price been laid out upon the bricks when they were first used, and had the houses been constructed to last a thousand instead of a hundred years. No doubt, certain advantages attend these ephemeral structures. The inhabitants are enabled, once every century, to suit their houses to the prevailing taste of the day. Thus, there are no antiquated houses in London. But as the increase of the price of all the materials of building has more than kept pace with the increase of the wealth of individuals, it is to be questioned whether the houses are always improved when they are pulled down and rebuilt.

2. The best material for making brick is what in the English language is called *loam*, a term usually applied to a natural mixture of sand and clay. Such a mixture may be converted into brick without any addition whatever. Marl likewise answers the purpose of common bricks very well,—indeed better than most other mixtures. Marl is a natural mixture of limestone and clay in variable proportions. Now, the more lime it contains, the better does it answer for a manure; and the less lime it contains, the more suitable it is to the brickmaker.

It would be in vain to attempt a particular detail of the constituents of clays, because they vary too much from each other to admit of any correct generalization. We believe, however, that clays very frequently consist of decomposed felspar, in which case we may conceive them as composed of about three parts of silica in the state of a very fine powder, and one part of alumina. This is the case with porcelain clay. Indeed, the porcelain clay of Cornwall appears incontrovertibly to be nothing else than decayed felspar, or perhaps felspar which never had assumed any other form than that of clay. The rock from which it is taken is an agglutinated mixture of quartz and this clay. The quartz is separated by washing. Such a rock might probably be converted into most beautiful brick, merely by cutting it out in the proper shape, and subjecting it to the requisite heat; or rather by kneading the whole into a paste with the requisite quantity of water, moulding it into bricks, and drying and burning them.

Potter's clay is a compound of

Silica	-	-	43.5
Alumina	-	-	33.2
Lime	-	-	3.5
Oxide of iron	-	-	1.0
Water	-	-	18.0
			99.2
Loss	-	-	8
Total	-	-	100.0

Brick.

When the clay proceeds from the decomposition of hornblende, as is likewise often the case, it contains about $3\frac{1}{2}$ parts of silica, 1 of alumina, 1 of lime, and about $1\frac{1}{2}$ of oxide of iron. Sometimes the grains of sand which exist in clay consist of fragments of felspar. In such cases the clay may be fused by heat.

No mixture of alumina and silica, in any proportions whatever, can be fused by the strongest heat which can be raised in our furnaces. Hence such mixtures are best adapted for making fire-bricks, crucibles, and glasshouse pots. Stourbridge clay is such a mixture, blackened by coaly matter. It answers these purposes better than any other clay in England. Neither can a mixture of lime and alumina be fused, in whatever proportions the ingredients be mixed. But a mixture of silica, lime, and alumina, is very fusible, and the fusion is most readily effected when we employ two parts of silica to one of lime. The presence of oxide of iron also renders clay fusible, but not unless its proportion be much greater than ever is likely to occur in any clay used for the manufacture of bricks.

For making common bricks, the most durable mixture ought to be common clay and limestone or chalk. Perhaps the best proportions would be three parts of clay, and one part of limestone or chalk in powder. When such a mixture is exposed to heat, it would experience an incipient fusion, and would thereby be rendered much harder and denser than common bricks. The consequence would be, that it would imbibe much less water, and would therefore be much less liable to crack and fall to pieces in winter than common bricks. For when water has insinuated itself into the pores of a common brick, and is converted into ice, it undergoes an expansion which dislocates the parts of the brick, and reduces it to fragments. This is often conspicuously the case with tiles, which, from their exposed situation, are more liable to be soaked with water than common bricks. Hence also covering the surface of the brick with a coating of paint has a great tendency to preserve them from cracking and breaking. This practice is frequently followed in England.

It would be foreign to the object of this article to enter into any long details respecting the chemical investigations, and the opinions entertained at different periods respecting the nature of clay. At first, it was supposed to be a peculiar species of earth, but Hellot demonstrated that it consisted at least of two constituents; for sulphuric acid had the property of destroying its plastic nature, and of rendering it scarcely more adhesive than sand. The

Brick.

portion that remained behind did not effervesce with acids. It was not, therefore, of a calcareous nature. Mr Pott went a step farther; he showed in the continuation of his *Lithogeognosis* that sulphuric acid formed, with the portion of clay which it dissolved, a salt possessing the properties of alum. In the year 1769, Baumé published his *Dissertation on Clays*, which he had drawn up in consequence of a premium offered by the Academy of Sciences at Bourdeaux, for the best solution of the following question: What are the principles and constituents of clay, and the natural changes which it experiences, and what are the methods of rendering it fertile? The Academy did not consider Baumé's solutions as satisfactory. He published his Memoir, in consequence, as a kind of defiance. He had been employed along with Macquer in making numerous experiments on clay, with a view to the improvement of the porcelain manufacture in France. Guided by these experiments, he drew as a conclusion that clay is a mixture of two different substances; 1. Silica in a state of purity; 2. Silica combined with an underdose of sulphuric acid. It was the second of these constituents that gave to clay its fatty and plastic nature. Margraaf had long before (in 1756) demonstrated that the ingredient of clay which Baumé took for a salt, and which he affirmed was soluble in water, was a peculiar species of earth, different from every other, which constitutes the basis of alum, which dissolves in sulphuric acid, but which does not form alum unless a portion of potash be added to the solution. Thus, by the labours of Hellot, Pott, Baumé, and Margraaf, the nature of clay was completely developed. It was ascertained to be a mixture of alumina and silica, in variable proportions. It was shown, also, that it sometimes contained sulphuric acid, and not unfrequently potash. Hence the reason why, in some cases, it could be converted into alum by digestion in sulphuric acid, without the necessity of adding any potash to the solution. Modern chemists have added considerably to these facts. They have shown that chalk, felspar, mica, hornblende, oxide of iron, coal, bitumen, &c. are not unfrequently mixed with it; and that these additions alter its qualities considerably, and render it fit or unfit for the different purposes to which clay is usually applied.

Preparation
of the Clay,
and Forma-
tion of the
Brick.

3. Clay intended to be made into bricks ought to be dug out of the earth, and exposed to the air and weather for a considerable time before it is employed. The longer this exposure is continued, so much the better will it be fitted for making bricks. This exposure answers a variety of purposes. If the stones, by the decomposition of which the clay has been formed, are not entirely decomposed, this exposure serves to complete the process, by promoting the disintegrating action of the air and rain. The exposure serves, likewise, to pulverize the clay, which is essential to the making of good bricks. We have little doubt that the same amelioration in the clay would be produced by simply drying it in the open air, and then grinding it to powder in a mill. By such a process, the quality of the bricks would be prodigiously improved. Nor do we conceive that such an addition would greatly enhance the expen-

ces of the brickmaker, at least in those districts where the mill could be driven by water.

Brick.

When the clay has been reduced to powder, the next step is to make it into a stiff paste with water. Too much water should not be employed, because it is injurious to the strength of the bricks; and the utmost care should be taken to mix the whole of the clay as equally as possible with the water. If some parts of the paste be moister than others, it will occasion an inequality in the texture of the bricks formed of it, will render them apt to crack, and will greatly injure both their strength and their beauty. Hence the great importance of working the clay for a considerable length of time before moulding it into bricks. It is in this part of the process that we believe British brickmakers in general are most defective. As far as we have had an opportunity of witnessing the process of kneading the clay, as conducted either in the neighbourhood of London or Edinburgh, we have always found a great sparing of labour. Hence we believe the reason why so many of the English bricks appear full of cracks, even when sold to the builder. Such bricks ought never to be purchased, as it is perfectly obvious that they cannot make a durable building.

The kneading of the clay is performed, in some places, by men's feet; in others, by the feet of horses, and in others by machinery. The last method is undoubtedly the best; and we conceive likewise that it might be made the cheapest. It would be easy to devise machinery for kneading the clay, upon principles similar to those employed in mashing by the London porter brewers. And, if such a machine were driven by water, we conceive that it would not be nearly so expensive as either men or horses.

When the clay is sufficiently kneaded, it is moulded into the form of a brick, by being put into a very simple wooden mould; and the upper part of the brick is made smooth and even by cutting off the superfluous part with a wooden knife. The process is very simple, and is conducted by the workmen with great rapidity. A good brickmaker will mould about 5000 bricks in a day. He disengages the bricks from the mould by a gentle stroke on the back of the mould; and the wet bricks are at first arranged in rows upon long boards. When sufficiently dry to be handled, they are turned, and at last piled up in loose walls, which are thatched with straw to keep off the rain. In this position they are allowed to remain till they have become as dry as they can become in the open air.

In many cases, the clay used for brick-making is destitute of the requisite quantity of sand. If such clay were made into bricks, it would shrink so much in the burning, that the bricks would lose their shape, and would probably crack in every direction. To prevent this, it is necessary to add a certain quantity of sand. This sand should not be very fine. It answers best when the particles are of such a size as to be readily distinguished by the naked eye. Even when as large as coriander seeds, it has been found to answer better than very fine sand. The brickmakers in the neighbourhood of London bring their sand from the bottom of the

Brick. Thames near Woolwich, where it is raised by boats employed for that purpose, and brought up the river for the use of the brickmakers.

Burning of the Bricks. 4. No general directions can be given respecting the quantity of sand to be mixed with the clay, because that depends upon the nature of the clay, and upon the uses for which the bricks are intended. The more sand is added, the more accurately do the bricks retain their shape, and the less apt are they to crack during the burning; but, at the same time, their strength is diminished. Chemical lutes are often composed of four parts of sand and one part of clay. Such mixtures do not contract much in burning, and, therefore, are not apt to crack and drop off, which is the reason why chemists employ them. But they have not the adhesiveness of brick after being burnt, and would not, therefore, answer the purposes of the brickmaker. In stone-ware, the mixture consists of about four parts of clay and one of fine sand. It burns to a hard, cohesive substance, capable of striking fire with steel. Such a proportion then, in many cases, would answer the purposes of the brickmaker.

The London brickmakers make another addition to the clay, which, we believe, is peculiar to them. They add to every three parts of the clay about one part of the ashes from the fire-places of the city of London. These ashes contain some earthy matter; but they consist, in a great measure, of small coal unburnt, and little altered, which has fallen through the interstices of the grate. The consequence is, that such a mixture, when sufficiently heated, takes fire and burns of itself, though very slowly; so that the London bricks are burnt, in a great measure, by means of the fuel mixed with the clay of which they are composed.

It is essential to dry the bricks thoroughly, in the open air, before burning them. For when heat is applied to wet clay, the water which it contains being prevented from escaping by the adhesiveness of the mixture, is converted into steam, and cracks and breaks the mass of clay to pieces. Indeed, after the bricks are rendered as dry as they can become in the open air, they ought to be exposed, at first, to a gentle heat, which ought to be raised to redness, very slowly, and in proportion as the moisture of the brick is dissipated. Water adheres with such obstinacy to clay, that it is never all driven off by the heat at which bricks are burnt. But the portion which remains is so intimately combined with the clay, as to constitute one solid mass, which has no great tendency to absorb an additional quantity of water.

Bricks are most commonly burnt in a kiln. This is a very simple structure, usually about 13 feet long, 10½ wide, and 12 feet high. The walls are one foot two inches thick, and inclinè a little to each other as they ascend. The bricks are placed on flat arches, having holes left in them like lattice-work. After the bricks are arranged on the kiln, to the number of about 20,000, they are covered with old bricks or tiles. Some brush-wood is then kindled in the kiln, and a moderate fire kept up till the bricks are rendered as dry as possible. The time required for this is two or three days, and the

Brick. bricks are known to be dry when the smoke (which is at first black) becomes transparent. The mouth of the kiln is then filled up with pieces of brick and clay, leaving only room to introduce a faggot at a time. This structure at the mouth of the kiln is called a *shinlog*. The kiln is then supplied with faggots of furze, heath, fern, or whatever vegetable substance can be procured at the cheapest rate, till the arches look white, and the fire appears at the top. The fire is then diminished, and at length allowed to go out, and the kiln is permitted to cool. This burning process usually lasts about forty-eight hours.

The method of burning bricks in the neighbourhood of London, is very different from this. We do not know whether it be practised any where else. It obviously originated from the difficulty of procuring a sufficient quantity of vegetable matter to burn the enormous number of bricks consumed every year in London. If we consider the immense extension of houses which has taken place in London within the last thirty years,—if we consider that this vast city, containing above 1,000,000 of inhabitants, is almost renewed once every century, we may be able to form some notion of the prodigious quantity of bricks which it must consume. In the country round London there is a particular kind of clay, well known by the name of London Clay. This clay is almost everywhere covered with a bed of gravel, which varies in thickness according to the elevation of the surface. Hence the whole of the country round London is fit for making bricks. Nothing more is necessary than to dig through the surface of gravel, and get to the clay.

We have already mentioned, that about a fourth part of the London bricks consists of small coal kneaded up along with the clay. When the bricks are sufficiently dry, they are piled up on each other in parallelopipedons to the intended height. Between each two rows of brick there is strewed a quantity of cinders, amounting to about three inches in thickness. At the distance of about nine feet from each other, perpendicular spaces are left, about a brick wide, which serve the purpose of flues. These are made by arching the bricks over so as to leave a space between each about a brick in width. Over the whole is strewed a pretty thick covering of cinders. The flues are filled likewise with cinders, or, if they cannot be had, with coal. The fire-place is usually at the west end, and is generally three feet high. The fire, when once kindled in the fire-place, propagates itself very slowly through the whole *clump*, as bricks piled in this manner are called. So very slow is the progress, that bricks in the neighbourhood of London take about three months in the burning. The heat is very intense, and, as the fuel is mixed up with the clay itself, every part of the brick is sure to be sufficiently burnt.

We conceive that the mixture of about one-fourth of chalk with the clay of which the London bricks are made, would greatly improve their quality. The consequence would be an incipient fusion, which would render their surface much more compact and solid. The only difficulty would be to proportion the quantity of chalk so as to prevent complete fu-

Brick- aion, which would run the bricks into each other, and destroy them entirely. Bricks made of materials which have undergone complete fusion, would be greatly superior to common bricks. They would perfectly resist the action of the weather, and would, therefore, last much longer than common bricks. In Sweden it is customary at some of the iron founderies, to cast the scoræ into bricks, which they employ in constructing their furnaces. Such furnaces the writer of this article has seen; and he was assured by the gentleman who had the charge of the works, that they answered fully better than common bricks. It would be easy to make any quantity of such bricks in some of the large iron founderies of Great Britain. We are persuaded that such bricks might be brought into use for a variety of purposes with great advantage, and might even constitute a lucrative article of manufacture. Bricks made from the scoræ of iron and copper founderies, would vie in beauty with marble and porphyry, and would possess a smoothness of surface and a lustre to which few marbles could reach.

Few parts of Great Britain are so well adapted for the making of bricks, according to the London plan, as the neighbourhood of Newcastle upon Tyne. There the enormous heaps of small coal, which are of no use whatever, would furnish abundance of fuel, at a much cheaper rate, than even the London ashes; while the magnesian limestone that occurs in such plenty in the neighbourhood of Sunderland, would enable the brickmaker to give the clay the requisite degree of fusibility.

As bricks form an article of taxation, and furnish a considerable revenue to Government, their size has been regulated by act of Parliament. They must not be less than $8\frac{1}{2}$ inches long, $2\frac{1}{2}$ thick, and 4 inches wide. But for various purposes, they are made of very different and very considerable sizes.

Fire-Bricks.

Fire-bricks are made in the same way as common bricks. But the materials are different. The best clay for their composition is Stourbridge clay; and, instead of sand, it is usual to mix the clay with a quantity of old fire-bricks, or crucibles, or glass pots, reduced previously to powder. This mixture answers the same purposes as sand, while it does not communicate the tendency to fusion, when it comes in contact with various fluxes, that is communicated by siliceous sand.

Swimming Bricks.

There is a kind of bricks mentioned by Pliny, as used by the ancients, which were so light as to swim in water. "Pitaneæ in Asia, et in ulterioris Hispaniæ civitatibus Maxilia et Calento, fiunt Lateres, qui ciccati non merguntur in aqua." (*Plinii Natur. Histor. lib. xxxv. c. 14.*) Pliny does not mention the part of the world in which the earth employed in the manufactures of these bricks was found; though in all probability, it could not be far from the cities where the bricks are said by Pliny to have been made. He says that the material employed was a kind of pumice stone. But it was quite unknown to the moderns, till, in the year 1791, Fabbroni found a substance at Castel del Piano, not far from Santa Fiora, situated between Tuscany and the Papal dominions, which formed bricks capable of

swimming in water. This is a white earthy matter, which constitutes a bed in that place, and was known in Italy by the name of *Latte di Luna*. In more recent mineralogical books, it is distinguished by the name of *farina fossilis (bergmehl)*. Haüy considers it as a variety of talc, and Brochant, as a variety of meerschaum. According to the analysis of Fabbroni, this substance is composed of

Silica	-	55
Magnesia	-	15
Alumina	-	12
Lime	-	3
Iron	-	1
Water	-	14
		<hr/>
		100

But it has been recently analyzed by Klaproth, who found its constituents,

Silica	-	79
Alumina	-	5
Oxide of iron	-	3
Water	-	12
Loss	-	1
		<hr/>
		100

We see from this analysis, that this mineral is neither a variety of talc nor of meerschaum. One would be disposed to consider it as a hydrate of silica. For both the alumina and oxide of iron are present in so small proportions, that we can scarcely consider them as in chemical combination.

Considering the composition of this earth, it is rather singular that it is capable of being agglutinated by a red heat. We rather suspect that the bricks of Fabbroni, which swim in water, have but very little strength. This, if it be the case, must greatly circumscribe their utility.

The colour of the London bricks is not red, as is the case with common bricks and tyles; but a light brownish yellow. This colour is more pleasing to the eye than common brick red, and on that account the London bricks are preferred for building houses. The brickmakers assign a curious enough reason for this colour. According to them, their bricks are kept as much as possible from the contact of air during their burning. The consequence of this is, that the iron contained in them is not oxidized to so great a degree as in common bricks. But this mode of reasoning is far from exact. If air were excluded entirely, the bricks would not be burnt at all, because the fire would be extinguished. But if enough of air be admitted to burn the coal mixed with the clay (which must be the case), that air must also act upon the iron, and reduce it to the state of peroxide. Indeed, there can be no doubt, that the iron in the London yellow bricks, is in the state of peroxide, as well as in the red bricks; for the peroxide of iron gives various colours to bodies, according to circumstances. We find bodies tinged with it, red, yellow,

Brick
|
Bridge.

and brown, according to the substances with which the oxide is combined. We ascribe the yellow colour of the London bricks to the ashes of the coals,

which, by uniting with the peroxides of iron, form a kind of yellow ochre.

Brick
|
Bridge.

B R I D G E.

THE mathematical theory of the structure of bridges has been a favourite subject with mechanical philosophers; it gives scope to some of the most refined and elegant applications of science to practical utility; and at the same time that its progressive improvement exhibits an example of the very slow steps by which speculation has sometimes followed execution, it enables us to look forwards with perfect confidence to that more desirable state of human knowledge, in which the calculations of the mathematician are authorised to direct the operations of the artificer with security, instead of watching with servility the progress of his labours.

Of the origin of the art of building bridges a sketch has been given in the body of the *Encyclopædia*; the subject has been rediscussed within the last twenty years by some of the most learned antiquaries, and of the most elegant scholars of the age; but additions still more important have been made to the scientific and practical principles on which that art depends; and the principal information, that is demanded on the present occasion, will be comprehended under the two heads of physico-mathematical principles, subservient to the theory of this department of architecture, and a historical account of the works either actually executed or projected, which appear to be the most deserving of notice. The first head will contain three sections, relating respectively (1) to the resistance of the materials employed, (2) to the equilibrium of arches, and (3) to the effects of friction; the second will comprehend (4) some details of earlier history and literature, (5) an account of the discussions which have taken place respecting the improvement of the port of London, and (6) a description of some of the most remarkable bridges which have been erected in modern times.

SECTION I.—Of the Resistance of Materials.

The nature of the forces on which the utility of the substances employed in architecture and carpentry depends, has been pretty fully investigated in the article STRENGTH of the *Encyclopædia*; and the theory has been carried somewhat further, in the investigations of a late writer concerning Cohesion and Passive Strength of materials. Much, however, still remains to be done; and we shall find many cases, in which the principles of these calculations admit of a more immediate and accurate application to practice than has hitherto been supposed. It will first be necessary to advert to the foundation of the theory in its simplest form, as depending on the attractive and repulsive powers, which balance each other, in all natural substances remaining in a permanent state of cohesion, whether as liquids, or as more or less perfect solids.

VOL. II. PART II.

A. In all homogeneous solid bodies, the resistances to extension and compression must be initially equal, and proportional to the change of dimensions.

The equilibrium of any body remaining at rest, depends on the equality of opposite forces, varying according to certain laws; and that these laws are continued without any abrupt change, when any minute alteration takes place in the distance, is demonstrated by their continuing little altered by any variation of dimensions, in consequence of an increase or diminution of temperature, and might indeed be at once inferred as highly probable, from the general principle of continuity observed in the laws of nature. We may, therefore, always assume a change of dimensions so small, that, as in all other differential calculations, the elements of the curves, of which the ordinates express the forces, as functions of, or as depending on, the distances as abscissæ, may be considered as not sensibly differing from right lines, crossing each other, if the curves be drawn on the same side of the abscissæ, in a point corresponding to the point of rest, or to the distance affording an equilibrium; so that the elementary finite differences of the respective pairs of ordinates, which must form, with the portions of the two curves, rectilinear triangles, always similar to each other, will always vary as the lengths of the elements of the curves, or as the elements of the abscissæ, beginning at the point of rest; and it is obvious that these differences will represent the actual magnitude of the resistances exhibited by the substance to extension or compression. (Plate XLII. fig. 1.)

It was on the same principle that Bernoulli long ago observed, that the minute oscillations of any system of bodies, whatever the laws of the forces governing them might be, must ultimately be isochronous, notwithstanding any imaginable variation of their comparative extent, the forces tending to bring them back to the quiescent position being always proportional to the displacements; and so far as the doctrine has been investigated by experiments, its general truth has been amply confirmed; the slight deviations from the exact proportion, which have been discovered in some substances, being far too unimportant to constitute an exception, and merely tending to show that these substances cannot have been perfectly homogeneous, in the sense here attributed to the word. When the compression or extension is considerable, there may indeed be a sensible deviation, especially in fibrous or stratified substances; but this irregularity by no means affects the admissibility of any of the conclusions which will be derived from this proposition.

B. The strength of a block or beam must be reduced to one half, before its cohesive and repulsive forces can both be called into action.

We must suppose the transverse sections of the

3 R

Bridge.

body to remain plane and perpendicular to the axis, whatever the point may be to which the force is applied, a supposition which will be correctly true, if the pressure be made by the intervention of a firm plate attached to each end, and which is perfectly admissible in every other case. Now, if the terminal plates remain parallel, it is obvious that the compression or extension must be uniformly distributed throughout the substance, which must happen when the original force is applied in the middle of the block; the centre of pressure or resistance, collected by the plate, acting like a lever, being then coincident with the axis. But when the plates are inclined, the resistance depending on the compression or extension will be various in different parts, and will always be proportional to the distance from the neutral point, where the compression ends and the extension begins, if the depth of the substance is sufficient to extend to this point; consequently the forces may always be represented, like the pressure of a fluid, at different depths, by the ordinates of a triangle; and their result may be considered as concentrated in the centre of gravity of the triangle, or of such of its portions as are contained within the depth of the substance; and when both extension and compression are concerned, the smaller force may be considered as a negative pressure, to be subtracted from the greater, as is usual when any other compound forces are supposed to act on a lever of any kind. Now, when the neutral point is situated in one of the surfaces of the block, the sum of all the forces is represented by the area of the triangle, as it is by that of the parallelogram when the plates remain parallel, and these areas being in either case equivalent to the same external force, it is obvious that the perpendicular of the triangle must be equal to twice the height of the parallelogram, indicating that the compression or extension of the surface in the one case is twice as great as the equal compression or extension in the other; and since there is always a certain degree of compression or extension which must be precisely sufficient to crush or tear that part of the substance which is immediately exposed to it, and since the whole substance must in general give way when any of its parts fail, it follows that the strength is only half as great in the former case as in the latter. And the centre of gravity of every triangle being at the distance of one-third of its height from the base, the external force must be applied, in order to produce such a compression or extension, at the distance of one sixth of the depth from the axis; and when its distance is greater than this, both the repulsive and cohesive forces of the substance must be called into action, and the strength must be still further impaired. (Plate XLII. fig. 2.)

C. *The compression or extension of the axis of a block or beam is always proportional to the force, reduced to the direction of the axis, at whatever distance it may be applied.*

We may suppose one of the inflexible plates, attached to the extremities of the block, to be continued to the given distance, and to act as a lever held in equilibrium by three forces, that is, by the

cohesive and repulsive resistances of the block, and the external force; and it is obvious that, as in all other levers, the external force will always be equal to the difference of the other two forces depending on the compression and extension, or to the mean compression or extension of the whole, which must also be the immediate compression or extension of the middle, since the figure representing the forces is rectilinear. And the effect will be the same, whatever may be the intermediate substances by which the force is impressed on the block, whether continued in a straight line or otherwise. When the force is oblique, the portion perpendicular to the axis will be resisted by the lateral adhesion of the different strata of the block, the compression or extension being only determined by the portion parallel to the axis; and when it is transverse, the length of the axis will remain unaltered. But the line of direction of the original force must always be continued till it meets the transverse section at any point of the length, in order to determine the nature of the strain at that point.

D. *The distance of the neutral point from the axis of a block or beam is to the depth, as the depth to twelve times the distance of the force, measured in the transverse section.*

Calling the depth a , and the distance of the neutral point from the axis x , the resistances may be expressed by the squares of $\frac{1}{2}a+x$ and $\frac{1}{2}a-x$, which are the sides of the similar triangles denoting the compression and extension (Prop. B.); consequently, the difference of these squares, $2ax$, will represent the external force (Prop. C.). But the distance of the centres of gravity of the two triangles must always be $\frac{2}{3}a$; and, by the property of the lever, making the centre of action of the greater resistance the fulcrum, as the external force is to the smaller resistance, so is this distance to the distance of the force from the centre of action of the greater resist-

$$\text{ance; or } 2ax : (\frac{1}{2}a+x)^2 = \frac{2}{3}a : \left(\frac{aa}{12x} - \frac{a}{3} + \frac{x}{3}\right);$$

and adding to this the distance of the centre of action from the axis, which must be $\frac{1}{2}a - \frac{1}{2}(\frac{1}{2}a+x)$

$$= \frac{1}{2}a - \frac{1}{2}x, \text{ we have } \frac{aa}{12x} \text{ for the distance of the}$$

force from the axis; whence, calling this distance

$$y, z = \frac{aa}{12y}.$$

E. *The power of a given force to crush a block is increased, by its removal from the axis, supposing its direction unaltered, in the same proportion as the depth of the block is increased by the addition of six times the distance of the point of application of the force, measured in the transverse section.*

Since the compression or extension of the axis is invariable, whatever the distance of the force may be, that of the nearest surface must be as much greater, by the properties of similar triangles, as the half depth, increased by the distance of the neutral

Bridge.

point, is greater than that distance itself, that is, in the ratio of $a + 6y$ to a , since x is to a as a to $12y$; (Prop. D.) and to $\frac{1}{2}a$ as a to $6y$: and the strength is reduced in the same proportion, as the partial compression or extension, by the operation of a given force, is increased. (Plate XLII. fig. 3.)

F. The curvature of the neutral line of a beam at any point, produced by a given force, is proportional to the distance of the line of direction of the force from the given point of the axis, whatever that direction may be.

Since the distance x of the neutral point from the axis is inversely as y , the distance of the force, and the radius of curvature, or the distance of the intersection of the planes of the terminal plates from the neutral point, must be to the distance x as the whole length of the axis is to the alteration of that length produced by the compression or extension, it follows that the radius of curvature must be inversely as the distance y , and inversely also as the compression, and the curvature itself must be conjointly as the force and as the distance of its application. If the direction of the force be changed, and the perpendicular falling from the given point of the axis on the line of the force be now called y , the distance of the force from the axis measured in the transverse section will be increased by the obliquity exactly in the same ratio as its efficacy is diminished, and the curvature of the neutral line will remain unaltered; although the place of that line will be a little varied, until at last it coincides with the axis, when the force becomes completely transverse: and the radius of curvature of the axis will always be to that of the neutral line as the acquired to the original length of the axis. (Plate XLII. fig. 4.)

G. The radius of curvature of the neutral line is to the distance of the neutral point as the original length of the axis to the alteration of that length; or as a certain given quantity to the external force: and this quantity has been termed the Modulus of elasticity.

Or $r : x = M : f$, and $r = \frac{Mx}{f} = \frac{Maa}{12fy}$, as is ob-

vious from the preceding demonstration; y being the distance of the line of the force from the given point, whatever its direction may be.

H. The flexibility, referred to the direction of the force, is expressed by unity, increased by twelve times the square of the distance, divided by that of the depth.

Making the alteration of the axis unity, the corresponding change at the distance y will be to 1 as

$z + y$ to z , or as $1 + \frac{y}{z}$ to 1, and will consequent-

ly be equal to $1 + \frac{12yy}{aa}$ (Prop. D.)

When the direction of the force becomes oblique, the actual compression of the axis is diminished, but its effect referred to that direction remains unaltered.

I. The total compression of a narrow block, pressed

in the direction of one of its diagonals, is twice as great as if the same force were applied in the direction of the axis.

This proposition affords a simple illustration of the application of the preceding one. Calling the length of any portion of the axis x , beginning from the middle, and neglecting the obliquity, the distance of the force may be called $y = nx$, and the compression in the line of the force being everywhere as

$1 + \frac{12yy}{aa}$, its fluxion will be $dx + dx \frac{12nnyx}{aa}$, and

the fluent $x + \frac{4n^2x^2}{aa}$, which, when $y = \frac{1}{2}a$, becomes

$x + x$, which is twice as great as if y were always $= 0$. But if the breadth of the block were considerable, so that it approached to a cube, the compression would vary according to a different law, each section parallel to the diagonal affording an equal resistance, and the exact solution of the problem would require

an infinite series for expressing the value of $\int n^2 dx$.

K. If a solid bar have its axis curved a little into a circular form, and an external force be then applied in the direction of the chord, while the extremities retain their angular position, the greatest compression or extension of the substance will ultimately be to the mean compression or extension which takes place in

the direction of the chord, as $1 + \frac{4h}{a}$ to $1 + \frac{16hh}{15aa}$; a

being the depth of the bar, and h the actual versed sine, or the height of the arch.

We must here separate the actions of the forces retaining the ends of the bar into two parts, the one simply urging the bar in the direction of the chord, and the other, which is of a more complicated nature, keeping the angular direction unaltered; and we must first calculate the variation of the angular situation of the ends, in consequence of the bending of the bar by the first portion, and then the strain required to obviate that change, by means of a force acting in the direction of the middle of the bar, while the ends are supposed to be fixed. If each half of the bar were rectilinear, these two strains would obviously be equal, and would neutralise each other in the middle of the halves, which might be considered as the meeting of the ends of two shorter pieces, acting transversely or obliquely on each other, without any strain; the curvature produced by the whole strain being elsewhere as the distance from the line joining these points. But, since the bar is supposed to be curved, it becomes necessary to determine the place of these neutral points, by calculating the change of its angular position throughout its extent.

Considering, first, the middle of the bar as fixed, and calling the angular extent of the variable arc x , beginning from the middle, and the radius r , the ordinate y , or the distance of the arc from the chord, will be $r \cos x - b$, b being the cosine of the whole arc; and the fluxion of the change of the angular situation, being as the strain and the fluxion of the arc conjointly, will be expressed by $pr \cos x dx - p \sin x dx$, of

Bridge.

which the fluent is $prfx - pbr$. In the second place, the curvature derived from the force acting between the two halves, when the ends are considered as fixed points, will be as $r - rcx$, and the fluent of the change of angular situation may be called $grx - grfx$; and at the end, when x becomes equal to c , the whole extent of the arc, these two deviations must destroy each other, since the positions of the middle and of the ends remain unaltered; consequent-

ly $prfc - pbc = grc - grfc$, whence $\frac{p}{q} = \frac{rc - rfc}{rfc - bc}$,

and the exact proportion of p to q may be found, by means of a table of sines. But when the arc is

small, fc being equal to $c - \frac{1}{2}c^3 + \frac{1}{120}c^5 \dots$, $rc - rfc$

is $\frac{1}{2}rc^3$, and $rfc - bc = (r-b)c - \frac{1}{2}rc^3$; now $r-b$, the versed sine of the arc, becomes ultimately $\frac{1}{2}rc^2$, and $(r-b)c = \frac{1}{2}rc^3$; therefore $p : q = \frac{1}{2} : \frac{1}{2} = 1 : 1$; that is, the strain at the middle, expressed by p , must be half as great as the strain at the ends, expressed by q : consequently, when the force is considered as single, the distance of the line of its direction from the summit must ultimately be one-third of the versed sine or height.

Now if we call any portion of the chord x , we have for the corresponding value of y , the distance from the line of direction of this force, $\sqrt{(r^2 - x^2)} - d$, and for the fluxion of the compression or extension in

the direction of the chord, $d x \left(1 + \frac{12xy}{aa} \right)$, which

will be true for both portions of the bar, whether y be positive or negative; but $y^2 = r^2 - x^2 + d^2 - 2d\sqrt{(r^2 - x^2)}$, and the fluent becomes $x +$

$$\frac{12}{aa} \left(r^2x - \frac{1}{2}x^3 + d^2x - 2d \left[r^2 \text{ ARC SINE } \frac{x}{r} - x\sqrt{(r^2 - x^2)} \right] \right).$$

When the arc is small, calling the whole versed sine h , we have $y = \frac{1}{2}h - \frac{xx}{2r}$,

and $y^2 = \frac{1}{4}h^2 - \frac{hx^2}{3r} + \frac{x^4}{4r^2}$, and the fluent is $x +$

$$\frac{12}{aa} \left(\frac{1}{2}h^2x - \frac{hx^3}{9r} + \frac{x^5}{20r^2} \right),$$

but when x becomes equal to the semichord c , h being $\frac{cc}{2r}$, the expres-

sion becomes $c + \frac{12}{aa} \left(\frac{c^5}{36r^2} - \frac{c^3}{18r^2} + \frac{c^5}{20r^2} \right) = c +$

$$\frac{4c^3}{15a^2} = c + \frac{16h^2c}{15a^2},$$

which shows the compression or extension in the line of the chord, while c expresses

Bridge.

that which the bar would have undergone if it had been straight, and the force had been immediately applied to the axis; the actual change being greater

in the proportion of $1 + \frac{16hh}{15aa}$ to 1.

The greatest strain will obviously be at the ends, where the distance from the line of direction of the force is the greatest, the compression or extension of the surface being here to that of the axis, as $c +$

$6y$ to a (Prop. E.) or as $1 + \frac{4h}{a}$ to 1; consequently

the compression or extension in the line of the chord is to the greatest actual change of the substance

as $1 + \frac{16hh}{15aa}$ to $1 + \frac{4h}{a}$.

Thus if the depth a were 10 feet, and the height or versed sine $h = 20$, the radius being very large, the whole compression of the chord would be to the whole compression of a similar substance, placed in the direction of the chord, as 5.267 to 1; and the compression at the surface of the ends would be to the compression of the axis there as 9 to 1; and disregarding the insensible obliquity, this compression may be considered as equal throughout the bar; so that the compression at the ends will be to the compression of the chord as 9 to 5.267, or as 17 to 10.

Supposing, for example, such a bar of iron to undergo a change of temperature of 32° of Fahrenheit, which would naturally cause it to expand or contract about $\frac{1}{1000}$ in all its dimensions; then the length of the chord, being limited by the abutments, must now be supposed to be altered $\frac{1}{1000}$ by an external force; and, at the extremities of the abutments, the compression and extension of the metal will amount to about $\frac{1}{1000}$; a change which is equivalent to the pressure of a column of the metal about 3900 feet in height, since M , the height of the modulus of elasticity, is found, for iron and steel, to be about 10,000,000 feet; and such would be the addition to the pressure at one extremity of the abutment, and its diminution at the other, amounting to about five tons for every square inch of the section, which would certainly require some particular precaution, to prevent the destruction of the stones forming the abutment by a force so much greater than they are capable of withstanding without assistance. Should such a case indeed actually occur, it is probable that the extremities would give way a little, and that the principal pressure would necessarily be supported nearer the middle, so that there would be a waste of materials in a situation where they could be spared, but imperfectly in resisting the thrust; an inconvenience which would not occur if the bar were made wider and less deep, especially towards the abutments.

SECTION II.—Of the Equilibrium of Arches.

We may now proceed to inquire into the mode of determining the situation and properties of the curve of equilibrium, which represents, for every part of a

Bridge. system of bodies supporting each other, the ~~general~~ ^{general} direction of their mutual pressure; remembering always that this curve is as much an imaginary line, as the centre of gravity is an imaginary point, the forces being no more actually collected into such a line than the whole weight or inertia of a body is collected in its centre of gravity. Indeed, the situation of the curve is even less definite than that of the centre of gravity, since in many cases it may differ a little according to the nature of the co-operation of the forces which it is supposed to represent. In reality, every gravitating atom entering the structure must be supported by some forces continued in some line, whether regular or irregular, to the fixed points or abutments, and every resisting atom partakes, in a mathematical sense, either positively or negatively, in transmitting a lateral pressure where it is required for supporting any part of the weight; and when we attempt to represent the result of all these collateral pressures by a simple curve, its situation is liable to a slight variation, according to the direction in which we suppose the co-operating forces to be collected. If, for instance, we wished to determine the stability of a joint, formed in a given direction, it would be necessary to consider the magnitude of the forces acting throughout the extent of the joint in a direction perpendicular to its plane, and to collect them into a single result, and it is obvious that the forces, represented by the various elementary curves, may vary very sensibly in their proportion, when we consider their joint operation on a vertical or on an oblique plane; although if the depth of the substance be inconsiderable, this difference will be wholly imperceptible, and in practice it may generally be neglected without inconvenience; calculating the curve upon the supposition of a series of joints in a vertical direction. If, however, we wish to be very minutely accurate, we must attend to the actual direction of the joints in the determination of the curve, and must consider, in the case of a bridge, the whole weight of the structure terminated by a given arch stone, with the materials which it supports, as determining the direction of the curve of equilibrium where it meets the given joint, instead of the weight of the materials terminated by a vertical plane passing through the point of the curve in question, which may sometimes be very sensibly less; this consideration being as necessary for determining the circumstances under which the joints will open, as for the more imaginary possibility of the arch stones sliding upwards or downwards. But we may commonly make a sufficiently accurate compensation for this difference, by supposing the specific gravity of the materials producing the pressure, and the curvature of the line which terminates them, to be a little increased, while the absciss remains equal to that of the curve of equilibrium intersecting the joints.

L. If two equal parallelepipeds be supported each at one end, and lean against each other at the other; so as to remain horizontal, the curve of equilibrium, representing the general effect of the pressure transmitted through them, will be of a parabolic form.

The pressure of the blocks, where they meet, will obviously be horizontal, but at the other ends it will be oblique, being the result of this horizontal pressure

Bridge. and of the whole weight of each block. And if we imagine the blocks to be divided into any number of parts, by sections parallel to the ends, which is the only way in which we can easily obtain a regular result, it is evident that the force exerted at any of these sections, by the external portions, must be sufficient to support the lateral thrust and the weight of the internal portions; and its inclination must be such that the horizontal base of the triangle of forces must be to the vertical perpendicular as the lateral thrust to the weight of the internal portion; or, in other words, the lateral thrust remaining constant, the weight supported will be as the tangent of the inclination. But calling the horizontal absciss x , and the vertical ordinate y , the tan-

gent of the inclination will be $\frac{dy}{dx}$; which, in the case

of a parallelepiped, must be proportional to the dis-

tance x from the contiguous ends; and $x \propto \frac{m dy}{dx}$;

consequently $x dx = m dy$, and $\frac{1}{2} x^2 = m y$, which is the equation of a parabola. It is usual in such cases to consider the thrusts as rectilinear throughout, and as meeting in the vertical line passing through the centre of gravity of each block; but this mode of representation is evidently only a convenient compendium.

If the blocks were united together in the middle, so as to form a single bar or lever, the forces would be somewhat differently arranged; the upper half of the bar would contain a series of elementary arches, shutting on a series of similar elementary chains in the lower half, so as to take off all lateral thrust from the supports at the ends.

With respect to the transverse strains of levers in general, it may be observed, that the most convenient way of representing them is to consider the axis of the lever as composed of a series of elementary bars, bisected, and crossed at right angles, by as many others extending across the lever, or rather as far as two-thirds of the half depth on each side, where the centre of resistance is situated. The transverse force must then be transmitted unaltered throughout the whole system, acting in contrary directions at the opposite ends of each of the elementary bars constituting the axis; and it must be held in equilibrium, with respect to each of the centres, considered as a fulcrum, by the general result of all the copular forces acting on the longer cross arms; that is, by the difference of the compression or extension on the different sides of the arms. This difference must therefore be constant; and in all such cases the strain or curvature must increase uniformly, and its fluxion must be constant; but if the transverse force be variable, as when the lever supports its own weight, or any further external pressure, the fluxion of the curvature must be proportional to it. Now the transverse force, thus estimated, being the sum of the weights or other forces acting on either side of the given point, the additional weight at the point will be represented by the fluxion of the weight, or by the second fluxion of the strain or curvature, which is ultimately as the

Bridge: fourth fluxion of the ordinate. Also, the fluxion of the strain being as the whole weight on each side, it follows that when the strain is a maximum, and its fluxion vanishes, the whole weight, or the sum of the positive and negative forces on either side, must also vanish; as Mr Dupin has lately demonstrated in a different manner.

M. In every structure supported by abutments, the tangent of the inclination of the curve of equilibrium to the horizon is proportional to the weight of the parts interposed between the given point and the middle of the structure.

The truth of this proposition depends on the equality of the horizontal thrust throughout the structure, from which it may be immediately inferred, as in the last proposition. The materials employed for making bridges are not uncommonly such, as to create a certain degree of lateral pressure on the outside of the arch; but as there must be a similar and equal pressure in a contrary direction against the abutment, its effects will be comprehended in the determination of the point at which the curve springs from the abutment, as well as in the direction of the curve itself; so that the circumstance does not afford any exception to the general truth of the law. It is, however, seldom necessary to include the operation of such materials in our calculations, since their lateral pressure has little or no effect at the upper part of the arch, which has the greatest influence on the direction of the curve; and it is also desirable to avoid the unnecessary employment of these soft materials, because they tend to increase the horizontal thrust, and to raise it to a greater height above the foundation of the abutment.

We have therefore generally $\int w dx = mt = m \frac{dy}{dx}$,

w being the height of uniform matter, pressing on the arch at the horizontal distance x from the vertex, t the tangent of the inclination of the curve of equilibrium, y its vertical ordinate, and m a quantity proportional to the lateral pressure, or horizontal thrust.

N. The radius of curvature of the curve of equilibrium is inversely as the load on each part, and directly as the cube of the secant of the angle inclination to the horizon.

The general expression for the radius of curvature is $r = \frac{(dx)^2}{dx ddy}$; and here, since $m dy = dx \int w dx$, dx being constant, $md^2y = w(dx)^2$; but dx being $= dx \sqrt{1+t^2}$, $\frac{(dx)^2}{ddy} = \frac{m}{w}(1+t^2)$, and $r = \frac{m}{w}(1+t^2)^{\frac{3}{2}}$;

and m being constant, r is inversely as the load w , and directly as the cube of the secant $\sqrt{1+t^2}$. The same result may also be obtained from a geometrical consideration of the magnitude of the versed sine of the elementary arc, and the effect of the obliquity of the pressure; the one varying as the square of the secant, the other as the secant simply.

O. Consequently, if the curve be circular, the load must be everywhere as the cube of the secant.

P. If the curve of equilibrium be parabolic, the load must be uniform throughout the span.

(Prop. L.) The uniformity of the load implies that the superior and inferior terminations of the arch, commonly called the extrados and intrados, should be parallel: but it is not necessary that either of them should be parabolic, unless we wish to keep the curve exactly in the middle of the whole structure. When the height of the load is very great in proportion to that of the arch, the curve must always be nearly parabolic, because the form of the extrados has but little comparative effect on the load at each point.

A parabola will therefore express the general form of the curve of equilibrium in the flat bands of brick or stone, commonly placed over windows and doors, which, notwithstanding their external form, may very properly be denominated flat arches. But if we consider the direction of the joints as perpendicular to the curve, it may easily be shown, from the properties of the wedge, that they must tend to a common axis, in order that the thrust may be equal throughout; and the curve must be perpendicular to them, and consequently circular; but the difference from the parabola will be wholly inconsiderable.

Q. For a horizontal extrados, and an intrados terminated by the curve itself, which, however, is a supposition merely theoretical, the equation of the curve

$$\text{is } x = \sqrt{mHL} \frac{y + \sqrt{yy-aa}}{a}.$$

Since in this case $w = y$ (Prop. M.) we have $\int y dx = m \frac{dy}{dx}$; and $md^2y = y(dx)^2$; whence, multiplying both sides by dy , we have $mdy d^2y = y dy (dx)^2$; and, taking the fluent, $\frac{1}{2} m (dy)^2 = \frac{1}{2} y^2 (dx)^2$, and $mt^2 = y^2$, which must be corrected by making $y = a$ when t vanishes, so that we shall have $mt^2 = y^2 - a^2$, and $y = \sqrt{a^2 + mt^2}$. But since $\frac{dy}{dx} = t = \sqrt{\frac{yy-aa}{m}}$,

$$dx = dy \sqrt{\frac{m}{yy-aa}}, \text{ and } x = \sqrt{mHL}$$

$(y + \sqrt{y^2 - a^2}) - \sqrt{mHL} a$; whence all the

points of the curve may be determined by means of a table of logarithms. But such a calculation is by no means so immediately applicable to practice, as has generally been supposed; for the curve of equilibrium will always be so distant from the intrados at the abutments, as to derange the whole distribution of the forces concerned.

R. For an arch of equable absolute thickness throughout its length, the equation is $x = \sqrt{y^2 - mm}$

$$\text{and } x = mHL \frac{y + \sqrt{yy-mm}}{m}.$$

The weight of any portion of, the half arch being represented by its length x , we have $x = m \frac{dy}{dx}$; but

$$dx = dy \sqrt{1 + \left(\frac{dx}{dy}\right)^2} = dy \sqrt{1 + \frac{mm}{x^2}},$$

Bridge. and $dy = \sqrt{\left(1 + \frac{mm}{xz}\right)} = \sqrt{\frac{xz}{xz + mm}}$, of which the

fluent is $\sqrt{(x^2 + m^2)}$, requiring no further correction than to suppose y initially equal to m ; and we have

$x = \sqrt{(y^2 - m^2)}$. Again, since $dx = dx \sqrt{\left(1 + \frac{xx}{mm}\right)}$

we find in the same manner $dx = \sqrt{\frac{mdx}{mm + xx}}$, and

$s = mHL \left(x + \sqrt{[mm + xx]}\right) - mHLM = mHL \frac{x+y}{m}$.

This curve will, therefore, in some cases, be identical with that of the preceding proposition. It is commonly called the catenaria, since it represents the form in which a perfectly flexible chain of equable thickness will hang by its gravity.

S. If the load on each point of an arch be expressed by the equation $w = a + bx^2$, the equation for the curve of equilibrium will be $my = \frac{1}{2}ax^2 + \frac{1}{12}bx^4$.

Since the whole load $\int w dx$ is here $ax + \frac{1}{3}bx^2$, we

have $m \frac{dy}{dx} = ax + \frac{1}{3}bx^2$, (Prop. M.) and $my = \frac{1}{2}ax^2$

$+ \frac{1}{12}bx^4$.

This expression will, in general, be found sufficiently accurate for calculating the form of the curve of equilibrium in practical cases; and it may easily be made to comprehend the increase of the load from the obliquity of the arch-stones. The ordinate y , at the abutment, being given, the value of m may be deduced from it: and since at the vertex my is simply $\frac{1}{2}ax^2$, the radius of curvature r will here be

$$\frac{rx}{2y} = \frac{m}{a}$$

T. If we divide the span of an arch into four equal parts, and add to the weight of one of the middle parts one-sixth of its difference from the weight of one of the extreme parts, we shall have a reduced weight, which will be to the lateral thrust as the height of the arch to half the span, without sensible error.

The weight of the half arch being expressed by $ax + \frac{1}{3}bx^2$ when x is equal to the whole span, if we substitute x for $\frac{1}{2}x$, it will become $\frac{1}{2}ax + \frac{1}{24}bx^2$, for

one of the middle parts, leaving $\frac{1}{2}ax + \frac{7}{24}bx^2$, for the

extreme part, which gives $\frac{6}{24}bx^2$ for the difference of the parts, and $\frac{1}{6}$ of this, added to the former quantity

makes it $\frac{1}{2}ax + \frac{1}{12}bx^2$: but since $my = \frac{1}{2}ax^2 + \frac{1}{12}bx^4$,

dividing by mx , we have $\frac{y}{x} = \frac{\frac{1}{2}ax + \frac{1}{12}bx^2}{m}$.

It is also obvious, that if we subtract, instead of adding, one-sixth of the difference, we have $\frac{1}{2}ax$;

and dividing by $\frac{1}{2}x$, we obtain a , and thence $r = \frac{m}{a}$, m being previously found by the proposition.

U. When the load is terminated by a circular or elliptical arc, $w = a + nb - n\sqrt{(b^2 - x^2)}$, and $my =$

$$\frac{1}{2}(a + nb)x^2 - \frac{1}{2}nb^2x \text{ ARC SINE } \frac{x}{b} - \frac{1}{2}nb^2\sqrt{(b^2 - x^2)} + \frac{1}{8}n(b^2 - x^2)^{\frac{3}{2}} + \frac{1}{3}nb^2.$$

The whole load $\int w dx$ is here $ax + nbx - \frac{1}{2}nb^2$

ARC SINE $\frac{x}{b} - \frac{1}{2}nx\sqrt{(b^2 - x^2)}$; and hence $my =$

$$\frac{1}{2}ax^2 + \frac{1}{2}nbx^2 - \frac{1}{2}nb^2x \text{ ARC SINE } \frac{x}{b} + \frac{1}{2}nb^2 -$$

$$\frac{1}{2}nb^2\sqrt{(b^2 - x^2)} + \frac{1}{8}n(b^2 - x^2)^{\frac{3}{2}} - \frac{1}{8}nb^3 \text{ (Prop. M.)}$$

And the radius of curvature at the vertex will again

be $\frac{m}{a}$. When the curve is circular, the axes of the

ellipsis being equal, $n = 1$.

If the extrados and intrados are concentric, the calculation requires us to take the difference between the results determining the weight for each curve: but it will commonly be equally accurate in such a case, to consider the depth of the load as uniform, at least when the joints are in the direction of the radii.

X. The abutment must be higher without than within, by a distance, which is to its breadth, as the horizontal distance of the centre of gravity of the half arch from the middle of the abutment is to the height of the middle of the key-stone above the same point.

This proposition follows immediately from the proportion of the horizontal thrust to the weight, determined by the property of the lever; the one acting at the distance of the height of the arch from the fulcrum, and the other at the distance of the centre of gravity from the abutment, so as to balance each other; and the oblique direction of the face of the abutment being perpendicular to the thrust compounded of these two forces. The same rule also serves for determining the proper position of the abutment of a beam or rafter of any kind, in order that it may stand securely, without the assistance of friction. But for a bridge, if we calculate the situation of the curve of equilibrium, we obtain the direction of the thrust at its extremity more conveniently, without immediately determining the place of the centre of gravity.

Y. In order that an arch may stand without friction or cohesion, a curve of equilibrium, perpendicular to all the surfaces of the joints, must be capable of being drawn within the substance of the blocks.

If the pressure on each joint be not exactly perpendicular to the surfaces, it cannot be resisted with-

Bridge.

out friction, and the parts must slide on each other: this, however, is an event that can never be likely to occur in practice. But if the curve, representing the general pressure on any joint, be directed to a point in its plane beyond the limits of the substance, the joint will open at its remoter end, unless it be secured by the cohesion of the cements, and the structure will either wholly fall, or continue to stand in a new form. (Plate XLII. fig. 5.)

From this condition, together with the determination of the direction of the joints already mentioned (Prop. P.), we may easily find the best arrangement of the joints in a flat arch; the object, in such cases, being to diminish the lateral thrust as much as possible, it is obvious that the common centre of the joints must be brought as near to the arch as is compatible with the condition of the circle remaining within its limits; and it may even happen that the superincumbent materials would prevent the opening of the joints even if the centre were still nearer than this: but if, on the other hand, the arch depended only on its own resistance, and the materials were in any danger of being crushed, it would be necessary to keep the circle at some little distance from its surfaces, even at the expence of somewhat increasing the lateral pressure.

When the curve of equilibrium touches the intrados of an arch of any kind, the compression at the surface must be at least four times as great as if it remained in the middle of the arch-stones (Prop. E.), and still greater than this if the cohesion of the cements is called into action. In this estimate we suppose the transverse sections of the blocks inflexible, so as to cooperate throughout the depth in resisting the pressure on any point; but in reality this cooperation will be confined within much narrower limits, and the diminution of strength will probably be considerably greater than is here supposed, whenever the curve approaches to the intrados of the arch.

The passage of the curve of equilibrium through the middle of each block is all that is necessary to insure the stability of a bridge of moderate dimensions and of sound materials. Its strength is by no means increased, like that of a frame of carpentry, or of a beam resisting a transverse force, by an increase of its depth in preference to any other of its dimensions: a greater depth does, indeed, give it a power of effectually resisting a greater force of external pressure derived from the presence of any occasional load on any part of the structure; but the magnitude of such a load is seldom very considerable, in proportion to the weight of the bridge.

It is of some importance, in these investigations, to endeavour to trace the successive steps by which the fabric of a bridge may commonly be expected to fail. Supposing the materials to be too soft, or the abutments insecure, or any part of the work to be defective, and to afford too little resistance, the length of the curve of the arch being diminished, or its chord extended, it will become flatter, and, consequently, sink; the alteration being by far the greatest, if other things are equal, where the depth is the least, that is, near the crown or key-stone; so that if the curvature was, at first, nearly equal through-

out, the crown will sink so much as to cause a rapid increase of curvature on each side in its immediate neighbourhood, which will bring the intrados up to the curve of equilibrium, or even above it, the form of this curve being little altered by the change of that of the arch. The middle remains firm, because the pressure is pretty equally divided throughout the blocks, but the parts newly bent give way to the unequal force, and chip a little at their internal surface; but being reduced in their dimensions by the pressure, they suffer the middle to descend still lower, and are, consequently, carried down with it, so as to be relieved from the inequality of pressure depending on their curvature, and to transfer the effect to the parts immediately beyond them, till these in their turn crumble, and by degrees the whole structure falls. (Plate XLII. fig. 6.)

This explanation will enable us to understand some observations and experiments which the late Professor Robison has related as somewhat paradoxical. He says, that an arch built "of an exceedingly soft and friable stone," the arch-stones being also too short, began to show signs of weakness by the stones chipping about ten feet from the middle, and that it afterwards split at the middle, and fifteen or sixteen feet on each side of it, and also at the abutments. And in some experiments on models of arches in chalk, he found, that "the arch always broke at some place considerably beyond another point, where the first chipping had been observed;" a circumstance which he has not succeeded in sufficiently explaining.

SECTION III.—Of the Effect of Friction.

The friction or adhesion of the substances, employed in Architecture, is of the most material consequence, for insuring the stability of the works constructed with them; and it is right that we should know the extent of its operation; it is not, however, often practically necessary to calculate its exact magnitude, because it would seldom be prudent to rely materially on it, the accidental circumstances of agitation or moisture tending very much to diminish its effect. Nor is the cohesion of the cements employed of much further consequence than as enabling them to form a firm connexion, by means of which the blocks may rest more completely on each other than they could do without it; for we must always remember, that we must lose at least half of the strength, before the cohesion of the solid blocks themselves, in the direction of the arch, can be called into action, and at least three fourths before the joints will have any tendency to open throughout their extent.

Z. The joints of an arch, composed of materials subject to friction, may be situated in any direction lying within the limits of the angle of repose; on either side of the perpendicular to the curve of equilibrium; the angle of repose being equal to the inclination to the horizon at which the materials begin to slide on each other; and the direct friction being to the pressure as the tangent of this angle is to the radius.

It is obvious, that any other force, as well as that

of gravity, will be resisted by the friction or adhesion of the surfaces when its direction is within the limits of the angle at which the substances begin to slide; and it may be inferred from the experiments of Mr Coulomb and Professor Vince, that this angle is constant, whatever the magnitude of the force may be, since the friction is very nearly proportional to the mutual pressure of the substances. The tendency of a body to descend along any plane being as much less than its weight as the height of the plane is less than its length, and the pressure on the plane being as much less than the weight as the length is greater than the horizontal extent, it follows, that, when the weight begins to overcome the friction, the friction must be to the pressure as the height of the plane to its horizontal extent, or as the tangent of the inclination to the radius.

This property of the angle of repose affords a very easy method of ascertaining, by a simple experiment, the friction of the materials employed: taking, for example, a common brick, and placing it, with the shorter side of its end downwards, on another which is gradually raised, we shall find that it will fall over without beginning to slide; and when this happens, the height must be half of the horizontal extent, a brick being twice as long as it is broad: in this case, therefore, the friction must be at least half of the pressure, and the angle of repose at least 30° ; and an equilateral wedge of brick could not be forced up by any steady pressure of bricks acting against its sides, in a direction parallel to its base. But the effects of agitation would make such a wedge totally insecure in any practical case; and the determination only serves to assure us, that a very considerable latitude may be allowed to the joints of our materials, when there is any reason for deviating from the proper direction, provided that we be assured of a steady pressure; and much more in brick or stone than in wood, and more in wood than in iron, unless the joints of the iron be secured by some cohesive connexion. It may also be inferred from these considerations, that the direction of the joints can never determine the direction of the curve of equilibrium crossing them, since the friction will always enable them to transmit the thrust in a direction varying very considerably from the perpendicular; although, with respect to any particular joint, of which we wish to ascertain the stability independent of the friction, it would be desirable to collect the result of the elements, of which that curve is the representative, with a proper regard to its direction.

SECTION IV.—*Earlier Historical Details.*

The original invention of arches, and the date of their general adoption in architecture, have been discussed with great animation by the late Mr King, Mr Dutens, and several other learned antiquaries. Mr King insisted that the use of the arch was not more ancient than the Christian era, and considered its introduction as one of the most remarkable events accompanying that memorable period. Mr Dutens appealed to the structure of the cloacæ, built by the Tarquins, and to the authority of Seneca, who ob-

erves, that the arch was generally considered as the invention of Democritus, a Philosopher who lived some centuries before Christ, but that, in his opinion, the simplicity of the principle could not have escaped the rudest architect; and, that long before Democritus, there must have been both bridges and doors, in both of which structures the arch was commonly employed. There do indeed appear to be solitary instances of arches more ancient than the epoch assigned by Mr King to their invention. We find arches concealed in the walls of some of the oldest temples extant at Athens; the cloacæ are said to be arched, not at the opening into the Tiber only, but to a greater distance within it than is likely to have been rebuilt at a later period for ornament; and the fragments of a bridge, still remaining at Rome, bear an inscription which refers its erection to the latter years of the Commonwealth. But it seems highly probable, that almost all the covered ways, constructed in the earlier times of Greece and Rome, were either formed by lintels, like doorways, or by stones overhanging each other, in horizontal strata, and leaving a triangular aperture, or by both these arrangements combined, as is exemplified in the entrance to the treasury of Atreus at Mycenæ, where the lintel has a triangular aperture over it, by which it is relieved from the pressure of the wall above; and this instance serves to show how different the distribution of the pressure on any part of a structure may be, from the simple proportions of the height of the materials above it. Some other old buildings, which have been supposed to be arched, have been found, on further examination, rather to resemble domes, which may be built without centres, and may be left open at the summit, the horizontal curvature producing a transverse pressure, which supports the structure without an ordinary key-stone. And this has been suspected to be the form of the roofs and ceilings of ancient Babylon, where Strabo tells us that the buildings were arched over or "camerated," for the purpose of saving timber: and the bridge of Babylon, which must have been of considerable antiquity, is expressly said, by Herodotus, to have consisted of piers of stone, with a road formed of beams of wood only. It may however be rejoined, that though a dome is not simply an arch, yet it exceeds it in contrivance and mechanical complication; it generally exerts a thrust, and requires either an abutment, or a circular tie; and it is scarcely possible that the inventor of a dome should not have been previously acquainted with the construction of a common arch. Besides the term CAMARA, the Greeks had also PSALIS, APSIS, and THOLUS; the last was particularly appropriate to circular domes; but the variety of appellations seems to prove that the thing must have been perfectly familiar; and the term PSALIS is supposed to have been applied from the appearance of the wedged arch-stones, viewed in their elevation, which could not have been observable in a dome of any kind.

From these outlines of the origin of the art of building bridges, we may pass on rapidly to the latest improvements which have been made, in Great Britain, and on the Continent, in the practice of this department of architecture. A very ample detail of

Bridge. the most important operations, that are generally required to be performed in it, may be found in the numerous Reports of the ingenious Mr Smeaton, published since his death by the Society of Civil Engineers in London. They contain a body of information comprehending almost every case that can occur to a workman, in the execution of such structures; and even where they have to record an accidental failure, the instruction they afford is not less valuable than where the success has been more complete.

Respecting the general arrangement of a bridge, and the number of arches to be employed, in the case of a wide river, Mr Smeaton has expressed his approbation of a few wide and flat arches, supported by good abutments, in preference to more numerous piers, which unnecessarily interrupt the water-way. In a case where a long series of small arches was required, he has made them so flat, and the piers so slight, that a single pier would be incapable of withstanding the thrust of its arch: but in order to avoid the destruction of the whole fabric in case of an accident, he has intermixed a number of stronger piers, at certain intervals, among the weaker ones. Where several arches, of different heights, were required, he commonly recommended different portions of the same circle for all of them; a mode which rendered the lateral thrust nearly equal throughout the fabric, and had the advantage of allowing the same centre to be employed for all, with some little addition at the ends to adapt it to the larger arches. He records the case of Old Walton bridge, in which the wooden superstructure had sunk two feet, so as to become part of a circle 700 feet in diameter, and the thrust, thus increased, had forced the piers considerably out of their original situation: a striking proof that the principles of the pressure of arches must not be neglected, even when frames of carpentry are concerned.

Mr Smeaton particularly describes the inconveniences arising from the old method of laying the foundations of piers, which was introduced soon after the Conquest, and which is particularly exemplified in London Bridge. The masonry commences above low water mark, being supported on piles, which would be exposed to the destructive alternation of moisture and dryness, with the access of air, if they were not defended by other piles, forming projections partly filled with stone, and denominated *sterlings*; which, in their turn, occasionally require the support and defence of new piles surrounding them, since they are not easily removed when they decay; so that, by degrees, a great interruption is occasioned by the breadth of the piers, thus augmented, requiring, for the transmission of the water, an increase of velocity, which is not only inconvenient to the navigation, but also carries away the bed of the river under the arches, and immediately below the bridge, making deep pools or excavations, which require from time to time to be filled up with rubble stones; while the materials, which have been carried away by the stream, are deposited a little lower down in shoals, and very much interfere with the navigation of the river. From these circumstances, as well as from the effects of time and

decay, it has happened, according to late reports, **Bridge.** that the repairs of London Bridge have often amounted, for many years together, to L. 4000 a year, while those of Westminster and Blackfriars Bridges have not cost so many hundreds. It is true, that the fall produces a trifling advantage in enabling the London water-works to employ more of the force of the tide in raising water for the use of the city; and this right, being established as a legal privilege, has long delayed the improvements, which might otherwise have been attempted, for the benefit of the navigation of the river. The interest of the proprietors of the water-works has been valued at L. 125,000; and it has been estimated that L. 50,000 would be required for the erection of steam-engines to supply their place; while, on the other hand, it is said that from thirty to forty persons, on an average, have perished annually from the dangers of the fall under the bridge. (Plate XLIII. fig. 7, 8.)

But Mr Smeaton, as well as his predecessor Mr Labeyle, appears sometimes to have gone into a contrary extreme, and to have been somewhat too sparing in the use of piles. It is well known that the opening of Westminster Bridge was delayed for two years on account of the failure of a pier, the foundation of which had been partly undermined by the incautious removal of gravel from the bed of the river, in its immediate neighbourhood; a circumstance which would scarcely have occurred if piles had been more freely employed in securing the foundation. The omission, however, did not arise from a want of a just estimate of the importance of piles in a loose bottom, but from a confidence, founded on examination as the work advanced, that the bed of the river was already sufficiently firm. Mr Smeaton directed the foundations of Hexham Bridge to be laid, as those of Westminster Bridge had been, by means of caissons, or boxes, made water-tight, and containing the bottom of the pier, completed in masonry well connected together, and ready to be deposited in its proper place by lowering the caissons, and then detaching the sides, which are raised for further use, from the bottoms, which remain fixed as a part of the foundations immediately resting on the bed of the river, previously made smooth for their reception, and sometimes also rendered more firm by piles and a grating of timber. By a careful examination of the bottom of the river at Hexham, Mr Smeaton thought he had ascertained that the stratum of gravel, of which it consisted, was extremely thin, and supported by a quicksand, much too loose to give a firm hold to piles, while he supposed the gravel strong enough to bear the weight of the pier, if built in a caisson. The bridge was a handsome edifice, with elliptical arches, and stood well for a few years; but an extraordinary flood occurred, which caused the water to rise five feet higher above than below the bridge, and to flow through it with so great a velocity, as to undermine the piers, and cause the bridge to divide longitudinally, and fall in against the stream; a circumstance so much the more mortifying to the eminent engineer who had constructed it, as it was the only one of his works that, "in a period of thirty years," had been known to fail. It was observed that some of the piers,

Bridge. which had been built in coffer-dams, with the assistance of some piles, withstood the violence of the flood; and it is remarkable, that the whole bridge has been rebuilt by a provincial architect with perfect success, having stood without any accident for many years.

It seems, therefore, scarcely prudent to trust any very heavy bridge to a foundation not secured by piles, unless the ground on which it stands is an absolute rock; and in this case, as well as when piles are to be driven and sawed off, it is generally necessary to have recourse to a coffer-dam. In the instance of the bridge at Harraton, for example, where the rock is nine feet below the bed of the river, Mr Smeaton directs that the piles forming the coffer-dam be rebated into each other, driven down to the rock, and secured by internal stretchers, before the water contained within them is pumped out. In some cases, a double row of piles, with clay between them, has been employed for forming a coffer-dam; but in others it has been found more convenient to drive and cut off the piles under water, by means of proper machinery, without the assistance of a coffer-dam.

Piles are employed of various lengths, from 7 to 15 feet or more, and from 8 to 10 inches in thickness, and they are commonly shod with iron. Smeaton directs them to be driven till it requires from 20 to 40 strokes of the pile driver to sink them an inch, according to the magnitude of the weight, and the firmness required in the work. He was in the habit of frequently recommending the piles surrounding the piers to be secured by throwing in rubble stone, so as to form an inclined surface, sloping gradually from the bridge upwards and downwards. In the case of Coldstream Bridge, it was also found necessary to have a partial dam, or artificial shoal, thrown across the river a little below the bridge, in order to lessen the velocity of the water, which was cutting up the gravel from the base of the piles. But all these expedients are attended with considerable inconvenience, and it is better to avoid them in the first instance by leaving the water-way as wide and as deep as possible, and by making the foundations as firm and extensive as the circumstances may require.

The angles of the piers, both above and under water, are commonly rounded off, in order to facilitate the passage of the stream, and to be less liable to accidental injury. Mr Smeaton recommends a cylindrical surface of 60° as a proper termination; and two such surfaces, meeting each other in an angle, will approach to the outline of the head of a ship, which is calculated to afford the least resistance to the water gliding by it.

We find that, in the year 1769, the earth, employed for filling up the space between the walls of the North Bridge in Edinburgh, had forced them out, so as to require the assistance of transverse bars and buttresses for their support. In the more modern bridges, these accidents are prevented by the employment of longitudinal walls for filling up the haunches, with flat stones covering the intervals between them, instead of the earth, or the more solid materials which were formerly used, and which produced a greater pressure both on the arch and on

the abutments, as well as a transverse thrust against the side walls. For the inclination of the road passing over this bridge, Mr Smeaton thought a slope of 1 in 12 not too great; observing that horses cannot trot even when the ascent is much more gradual than this, and that if they walk, they can draw a carriage up such a road as this without difficulty: and, indeed, the bridge at Newcastle appears, for a short distance, to have been much steeper. But it has been more lately argued, on another occasion, that it is a great inconvenience in a crowded city, to have to lock the wheel of a loaded waggon; that this is necessary at all times on Holborn Hill, where the slope is only 1 in 18; while in frosty weather this street is absolutely impassable for such carriages; and the descent of Ludgate Hill, which is only 1 in 36, is considered as much more desirable, when it is possible to construct a bridge with an acclivity so gentle.

SECTION V.—Improvements of the Port of London.

From the study of Mr Smeaton's diversified labours, we proceed to take a cursory view of the Parliamentary Inquiry respecting the improvement of the Port of London, which has brought forwards a variety of important information, and suggested a multiplicity of ingenious designs. The principal part of that which relates to our present subject is contained in the Second and Third Reports from the Select Committee of the House of Commons, on the improvement of the Port of London; ordered to be printed 11th July 1799, and 28th July 1800.

We find in these Reports some interesting details respecting the history of London Bridge, which appears to have been begun, not, as Hume tells us, by William Rufus, who was killed in 1100, but in 1176, under Henry II.; and to have been completed in 83 years. The piles are principally of elm, and they have remained for six centuries without material decay; although a part of the bridge fell, and was rebuilt about 100 years after it was begun. Rochester, York, and Newcastle Bridges were also built in the twelfth century, as well as the Bridge of St Esprit at Avignon. About 50 years ago, the middle pier of London Bridge was removed; the piles were drawn by a very powerful screw, commonly used for lifting the wheels of the water-works; and a single arch was made to occupy the place of two. In consequence of this, the fall was somewhat diminished, and it was necessary partially to obstruct the channel again, in order that the stream should have force enough for the water-works; but it was very difficult to secure the bottom from the effects of the increased velocity under the arch. Several strong beams were firmly fixed across the bed of the river, but only two of them retained their situations for any length of time; and the materials carried away had been deposited below the middle arch, so as to form a shoal, which was only 16 inches below the surface at low water. The Reports contain also much particular information respecting Blackfriars Bridge, the piles for which were driven under water, and cut off level with the bed of the foundations, by a machine of Mr Mylne's invention. The expense of Blackfriars Bridge, including the

Bridge. purchase of premises, was about L. 260,000; that of the building only was L. 170,000. Westminster Bridge, built in the beginning of the century, cost about L. 400,000.

The committee had received an immense variety of plans and proposals for docks, wharfs, and bridges, and many of these have been published in the Reports, together with engraved details on a very ample scale. They finally adopted three resolutions respecting the rebuilding of London Bridge.

"1. That it is the opinion of this Committee, that it is essential to the improvement and accommodation of the port of London, that London Bridge should be rebuilt upon such a construction as to permit a free passage, at all times of the tide, for ships of such a tonnage, at least, as the depth of the river would admit of, at present, between London Bridge and Blackfriars Bridge.

"2. That it is the opinion of this Committee, that an iron bridge, having its centre arch not less than 65 feet high in the clear, above high-water-mark, will answer the intended purpose, and at the least expense.

"3. That it is the opinion of this Committee, that the most convenient situation for the New Bridge, will be immediately above St Saviour's Church, and upon a line from thence to the Royal Exchange."

In a subsequent Report, ordered to be printed 3d June 1801, we find a plan for a magnificent iron bridge of 600 feet span, which had been submitted to the Committee by Messrs Telford and Douglas. Mr Telford's reputation in his profession as an engineer deservedly attracted the attention of the Committee; but many practical difficulties having been suggested to them, they circulated a number of queries relating to the proposal, among such persons of science, and professional architects, as were the most likely to have afforded them satisfactory information. But the results of these inquiries are not a little humiliating to the admirers of abstract reasoning and of geometrical evidence; and it would be difficult to find a greater discordance in the most heterodox professions of faith, or in the most capricious variations of taste, than is exhibited in the responses of our most celebrated professors, on almost every point submitted to their consideration. It would be useless to dwell on the numerous errors with which many of the answers abound; but the questions will afford us a very convenient clue for directing our attention to such subjects of deliberation as are really likely to occur in a multiplicity of cases; and it will perhaps be possible to find such answers for all of them, as will tend to remove the greater number of the difficulties which have hitherto embarrassed the subject.

QUESTIONS RESPECTING THE CONSTRUCTION OF A CAST IRON BRIDGE, OF A SINGLE ARCH, 600 FEET IN THE SPAN, AND 65 FEET RISE. (Plate XLII. fig. 7.)

1. *What parts of the bridge should be considered as wedges, which act on each other by gravity and pressure, and what parts as weight, acting by gravity only, similar to the walls and other loading, usually*

erected upon the arches of stone bridges. Or does the whole act as one frame of iron, which can only be destroyed by crushing its parts?

The distribution of the resistance of a bridge may be considered as in some measure optional, since it may be transferred from one part of the structure to another, by wedging together most firmly those parts which we wish to be most materially concerned in it. But there is also a natural principle of adjustment, by which the resistance has a tendency to be thrown where it can best be supported; for the materials being always more or less compressible, a very small change of form, supposed to be equal throughout the structure, will relieve those parts most which are the most strained, and the accommodation will be still more effectual when the parts most strained undergo the greatest change of form. Thus, if the flatter ribs, seen at the upper part of the proposed structure, supported any material part of its weight, they would undergo a considerable longitudinal compression, and being shortened a little, would naturally descend very rapidly upon the more curved, and consequently stronger parts below, which would soon relieve them from the load improperly allotted to them; the abutment would also give way a little, and be forced out, by the greater pressure at its upper part, while the lower part remained almost entirely unchanged.

It is, however, highly important that the work should, in the first instance, be so arranged as best to fulfil the intended purposes, and especially that such parts should have to support the weight as are able to do it with the least expense of lateral thrust, which is the great evil to be dreaded in a work of these gigantic dimensions, the materials themselves being scarcely ever crushed, when the arch is of a proper form; and the failure of an iron bridge, by the want of ultimate resistance of its parts to a compressing force, being a thing altogether out of our contemplation; and it is obvious that the greater the curvature of the resisting parts, the smaller will be the lateral thrust on the abutments.

We may, therefore, sufficiently answer this question, by saying, that the whole frame of the proposed bridge, so far as it lies in or near the longitudinal direction of the arch, may occasionally cooperate in affording a partial resistance if required; but that the principal part of the force ought to be concentrated in the lower ribs, not far remote from the intrados.

But it is by no means allowable to calculate upon a curve of equilibrium exactly coinciding with the intrados; since, if this supposition were realized, we should lose more than three-fourths of the strength of our materials, and all the stability of the joints independent of cohesion, so that the slightest external force might throw the curve beyond the limits of the joint, and cause it to open. Nor can we always consider the curve of equilibrium as parallel to the intrados: taking, for example, the case of a bridge like Blackfriars, the curve of equilibrium, passing near the middle of the arch-stones, is, and ought to be, nine or ten feet above the intrados at the abutment, and only two or three feet at the crown; so

Bridge. that the ordinates of this curve are altogether different from the ordinates which have hitherto been considered by theoretical writers. It may be imagined that this difference is of no great importance in practice; but its amount is much greater than the difference between the theoretical curves of equilibrium, determined by calculation, and the commonest circular or elliptical arches.

With respect to the alternative of comparing the bridge with masonry or with carpentry, we may say, that the principles on which the equilibrium of bridges is calculated, are altogether elementary, and independent of any figurative expressions of strains and mechanical purchase, which are employed in considering many of the arrangements of carpentry, and which may indeed, when they are accurately analysed, be resolved into forces opposed and combined in the same manner as the thrusts of a bridge. It is, therefore, wholly unnecessary, when we inquire into the strength of such a fabric, to distinguish the thrusts of masonry from the strains of carpentry, the laws which govern them being not only similar but identical; except that a strain is commonly understood as implying an exertion of cohesive force, and we have seen that a cohesive force ought never to be called into action in a bridge, since it implies a great and unnecessary sacrifice of the strength of the materials employed. If, indeed, we wanted to cross a mere ditch, without depending on the firmness of the bank, we might easily find a beam of wood or a bar of iron strong enough to afford a passage over it, unsupported by any abutment, because, in a substance of inconsiderable length, we are sure of having more strength than we require. But to assert that an iron bridge of 600 feet span "is a lever exerting a vertical pressure only on the abutments," is to pronounce a sentence from the lofty tribunal of refined science, which the simplest workman must feel to be erroneous. But, in this instance, the error is not so much in the comparison with the lever, as in the inattention to the mode of fixing it: for a lever or beam of the dimensions of the proposed bridge, lying loosely on its abutments, would probably be at least a hundred times weaker than if it were firmly connected with the abutments as a bridge is, so as to be fixed in a determinate direction. And the true reason of the utility of cast iron for building bridges, consists not, as has often been supposed, in its capability of being united so as to act like a frame of carpentry, but in the great resistance which it seems to afford to any force tending to crush it.

QUESTION II. *Whether the strength of the arch is affected, and in what manner, by the proposed increase of its width towards the two extremities or abutments, when considered vertically and horizontally. And if so, what form should the bridge gradually acquire?*

The only material advantage, derived from widening the bridge at the ends, consists in the firmness of the abutments; and this advantage is greatly diminished by the increase of horizontal thrust which is occasioned by the increase of breadth; while the curve of equilibrium is caused to deviate greatly

from a circular or parabolic arc, in consequence of the great inequality of the load on the different parts; and there seems to be no great difficulty in forming a firm connexion between a narrow bridge and a wider abutment, without this inconvenience. The lateral strength of the fabric, in resisting any horizontal force, would be amply sufficient, without the dilatation at the ends. Perhaps the form was suggested to the inventor by the recollection of the partial failure of an earlier work of the same kind, which has been found to deviate considerably from the vertical plane in which it was originally situated: but in this instance there seems, if we judge from the engravings which have been published, to have been a total deficiency of oblique braces; and the abutments appear to have been somewhat less firm than could have been desired, since one of them contains an arch and some warehouses, instead of being composed of more solid masonry. (Plate XLIII. fig. 9.)

QUESTION III. *In what proportions should the weight be distributed from the centre to the abutments, to make the arch uniformly strong?*

This question is so comprehensive, that a complete answer to it would involve the whole theory of bridges; and it will be necessary to limit our investigations to an inquiry whether the structure, represented in the plan, is actually such as to afford a uniform strength, or whether any alterations can be made in it, compatible with the general outlines of the proposal, to remedy any imperfections which may be discoverable, in the arrangement of the pressure.

There is an oversight in some of the official answers to this question, from quarters of the very first respectability, which requires our particular attention. The weight of the different parts of the bridge has been supposed to differ so materially from that which is required for producing an equilibrium in a circular arch of equable curvature, that it has been thought impossible to apply the principles of the theory in any manner to an arch so constituted, at the same time that the structure is admitted to be tolerably well calculated to stand, when considered as a frame of carpentry. The truth is, that it is by no means absolutely necessary, nor often perfectly practicable, that the mean curve of equilibrium should agree precisely in its form with the curves limiting the external surfaces of the parts bearing the pressure, especially when they are sufficiently extensive to admit of considerable latitude within the limits of their substance. It may happen in many cases, that the curve of equilibrium is much flatter in one part, and more convex in another, than the circle which approaches nearest to it; and yet the distance of the two curves may be inconsiderable, in comparison with the thickness of the parts capable of co-operating in the resistance. The great problem, therefore, in all such cases, is, to determine the precise situation of the curve of equilibrium in the actual state of the bridge; and when this has been done, the directions of the ribs, in the case of an iron bridge, and of the joints of the arch-stones, in a stone bridge, may be so regulated as to afford the

Bridge.

greatest possible security; and if this security is not deemed sufficient, the whole arrangement must be altered.

Considering the effect of the dilatation at the ends in increasing the load, we may estimate the depth of the materials causing the pressure at the abutments as about three times as great as at the crown; the plan not being sufficiently minute to afford us a more precise determination; and it will be quite accurate enough to take $w = a + bx^2$ (Prop. S.) for the load, w becoming = $3a$ when x is 300

feet, whence $90,000 b = 2a$, and $b = \frac{1}{45,000} a$; we

have then $my = \frac{1}{2} ax^2 + \frac{1}{540,000} ax^4$ for the value

of the ordinate. Now the obliquity to the horizon being inconsiderable, this ordinate will not ultimately be much less than the whole height of the arch; and its greatest value may be called 64 feet; consequently when $x = 300$, we have $64 m = \frac{1}{2} a \times$

$90,000 + \frac{1}{2} a \times 90,000$, and the radius of curva-

ture at the vertex $r = \frac{m}{a} = 937.5$ feet, while the

radius of the intrados is 725 feet, and that of a circle passing through both ends of the curve of equilibrium, as we have supposed them to be situated, 735 feet. Hence, y being = $\frac{1}{1875} x^2 \left(1 + \frac{1}{270000} x^2 \right)$, we may calculate the ordinates at different points, and compare them with those of the circular curves.

Hence, y being = $\frac{1}{1875} x^2 \left(1 + \frac{1}{270000} x^2 \right)$, we may calculate the ordinates at different points, and compare them with those of the circular curves.

Distance x .	Versed sine of the intrados.	Versed sine of the circular asc.	Ordinate y .
50	1.73	1.71	1.34
100	6.94	6.82	5.38
150	15.66	15.48	13.00
200	28.13	27.70	24.50
250	44.42	43.81	41.01
300	65.00	64.00	64.00

Hence it appears that, at the distance of 200 feet from the middle, the curve of equilibrium will rise more than 8 feet above its proper place; requiring a great proportion of the pressure to be transferred to the upper ribs, with a considerable loss of strength, for want of a communication approaching more nearly to the direction of the curve. If we chose to form the lower part of the structure of two series of frames, each about 4 feet deep, with diagonal braces, we might provide amply for such an irregularity in the distribution of the pressure; but it would be necessary to cast the diagonals as strong as the blocks, in order to avoid the inequality of tension from unequal cooling, which is often a cause of dangerous accidents; it would, however, be much better to have the arch somewhat elliptical in

Bridge.

its form, if the load were of necessity such as has been supposed.

QUESTION 4. *What pressure will each part of the bridge receive, supposing it divided into any given number of equal sections, the weight of the middle section being given. And on what parts, and with what force, will the whole act upon the abutments?*

It appears from the preceding calculations, that the weight of the "middle section" alone is not sufficient for determining the pressure in any part of the fabric; although, when the form of the curve of equilibrium has been found, its radius of curvature at the summit must give at once the length of a similar load equivalent to the lateral thrust; and by combining this thrust with the weight, or with the direction of the curve, the oblique thrust at any part of the arch may be readily found. Thus, since at the abutment $w = a + bx^2 = 3a$, and $bx^2 = 2a$,

we have $y = \frac{1}{2} \frac{a}{m} x^2 + \frac{1}{12} \frac{b}{m} x^4$, and $\frac{dy}{dx}$, the tangent

of the inclination, becomes = $\frac{a}{m} x + \frac{1}{3} \frac{b}{m} x^3 =$

$\frac{ax}{m} + \frac{2ax}{3m} = \frac{5x}{3m} = \frac{5 \cdot 300}{3 \cdot 937.5} = \frac{8}{15} = .5333$; conseq-

quently the horizontal thrust will be to the weight of the half arch as 15 to 8, and to that of the whole arch as 15 to 16. Now the arch is supposed to contain 6500 tons of cast iron, and together with the road, will amount, according to Professor Robison's estimate, to 10,100 tons; so that the lateral thrust on each abutment is 9470 tons; and since this is equal to the weight of 937.5 feet in length, of the thickness of the crown, the load there must be about 10 tons for each foot of the length. Hence, it appears, that although the thrust, thus calculated, is greater than the weight of a portion of equal length with the apparent radius at the crown, it is less than would be inferred from the angular direction of the intrados at the abutment: the inclination of the termination of the arch being $24^\circ 27'$, while that of the true curve of equilibrium is $28^\circ 4'$; that is, about one-tenth greater.

As a further illustration of the utility of this mode of computation, we may take the example of an arch of Blackfriars Bridge. The radius of curvature, as far as four-fifths of the breadth, is here 56 feet; and we may suppose, without sensible error, the whole load to be that which would be determined by the continuation of the same curve throughout the breadth. Now, the middle of the arch stones, at the distance of 50 feet from the middle of the bridge, that is, immediately over the termination of the abutment, is about 12 feet above that termination, and at the crown about three feet above the intrados, so that we have only 31 feet for the extreme value of y , while the whole height of the arch is 40; and a being 6.58 feet, we find (Prop. U.) $my = 13,510 = 31m$, whence $m = 436$, and $\frac{m}{a} = r = 66\frac{1}{2}$; we

also obtain the values of the ordinates of the curve as in the annexed table.

Distance x.	Ordinate y.	Middle of the Arch-Stones.
10 FEET	.76	.90
20	3.12	3.72
25	5.13	6.12
30	7.71	8.75
40	15.81	16.81
50	31.00	31.00

Hence it appears that the greatest deviation is about 30 feet from the middle, where it amounts to a little more than a foot. But if we suppose this deviation divided by a partial displacement of the curve at its extremities, as it would probably be in reality, even if the resistance were confined to the arch-stones, it would be only about half as great in all three places; and even this deviation will reduce the strength of the stones to two-thirds, leaving them however still many times stronger than can ever be necessary. The participation of the whole fabric, in supporting a share of the oblique thrust, might make the pressure on the arch-stones somewhat less unequal, and the diminution of their strength less considerable; but it would be better that the pressure should be confined almost entirely to the arch-stones, as tending less to increase the horizontal thrust, which is here compressed by $m = 436$, implying the weight of so many square feet of the longitudinal section of the bridge; while, if we determined it from the curvature of the intrados, it would appear to be only $56a = 368$.

In this calculation, the oblique direction of the joints, as affecting the load, has not been considered; but its effect may be estimated by merely supposing the specific gravity of the materials to be somewhat increased. Thus, since the back of each arch-stone is about one-eighth wider than its lower end, the weight of the materials pressing on it will be about one-sixteenth greater than would press on it, if it were of uniform thickness; and this increase will be very nearly proportional to w , the whole load at each part; so that it will only affect the total magnitude of the thrust, which, instead of 436, must be supposed to amount to about 463. If also great accuracy were required, it would be necessary to appreciate the different specific gravities of the various materials constituting the load; since they are not altogether homogeneous; but so minute a calculation is not necessary in order to show the general distribution of the forces concerned, and the sufficiency of the arrangement for answering all the purposes intended.

QUESTION 5. *What additional weight will the bridge sustain, and what will be the effect of a given weight placed upon any of the before mentioned sections?*

When a weight is placed on any part of a bridge, the curve of equilibrium must change its situation more or less, according to the magnitude of the weight; and the tangent of its inclination must now be increased by a quantity proportional to the additional pressure to be supported, which, if the weight were placed in the middle of the arch, would always be equal to half of it; but when the weight is placed at any other part of the arch, if we find the point where the whole thrust is horizontal, the vertical

pressure to be supported at each point of the curve must obviously be equal to the weight of the materials interposed between it and this new summit of the curve. Now, in order to find where the thrust is horizontal, we must divide the arch into two such portions, that their difference, acting at the end of a lever of the length of half the span, that is, of the distance from the abutment, may be equivalent to the given weight, acting on a lever equal to its distance from the other abutment, to which it is nearest; consequently this difference must be to the weight as the distance of the weight from the end to half the span; and the distance of the new summit of the curve from the middle must be such, that the weight of materials intercepted between it and the middle shall be to the weight as the distance of the weight from the end to the whole span; and the tangent of the inclination must everywhere be increased or diminished by the tangent of the angle at which the lateral thrust would support the weight of this portion of the materials; except immediately under the weight, where the two portions of the curve will meet in a finite angle, at least if we suppose the weight to be collected in a single point.

If, for example, a weight of 100 tons, equal to that of about 10 feet of the crown of the arch, be placed half-way between the abutment and the middle; then the vertex of the curve, where the thrust is horizontal, will be removed $2\frac{1}{2}$ feet towards the weight; but the radius being 937.5 feet, the

tangent of the additional inclination will be $\frac{2.5}{937.5} = \frac{1}{375}$, and each ordinate of the curve will be in-

creased $\frac{1}{375}$ of the absciss, reckoning from the place of the weight to the remoter abutment; but between the weight and the nearest abutment, the additional pressure at each point will be $10 - 2.5 = 7.5$ feet, consequently the tangent will be $\frac{1}{125}$, and the addi-

tions to the ordinates at the abutments will be $\frac{450}{375}$

and $\frac{150}{125}$, each equal to $1\frac{1}{2}$ foot, and at the summit

$\frac{150}{375} = \frac{2}{5}$, which, being deducted, the true addition

to the height of the curve will appear to be $\frac{4}{5}$.

But the actual height will remain unaltered, since the curve is still supposed to be terminated by the abutments, and to pass through the middle of the key-stone; and we have only to reduce all the ordinates in the proportion of 64.8 to 64. Thus, at 200 feet from the summit, the ordinate, instead of 24.50

+ $\frac{200}{875} = 25.03$, will be 24.72, so that the curve

will be brought $2\frac{1}{2}$ inches nearer to the intrados, which, in the proposed fabric, would by no means

Bridge. diminish its strength; while, on the opposite side, immediately under the weight, the ordinate 13 —

$$\frac{150}{375} = 12.6 \text{ will be reduced to } 12.45, \text{ and the curve}$$

raised between six and seven inches, which is a change by no means to be neglected in considering the resistances required from each part of the structure. We ought also, if great accuracy were required, to determine the effect of such a weight in increasing the lateral thrust, which would affect in a slight degree the result of the calculation; but it would not amount, in the case proposed, to more than one-eightieth of the whole thrust.

It is obvious that the tendency of any additional weight, placed near the middle of a bridge, is to straighten the two branches of the curve of equilibrium, and that, if it were supposed infinite, it would convert them into right lines; provided, therefore, that such right lines could be drawn without coming too near the intrados at the haunches, the bridge would be in no danger of giving way, unless either the materials were crushed, or the abutments were forced out. In fact, any bridge well constructed might support a load at least equal to its own weight, with less loss of strength than would arise from some such errors, as have not very uncommonly been committed, even in works which have on the whole succeeded tolerably well.

QUESTION 6. *Supposing the bridge executed in the best manner, What horizontal force will it require, when applied to any particular part, to overturn it, or press it out of the vertical plane?*

If the bridge be well tied together, it may be considered as a single mass, standing on its abutments; its mean breadth being about 80 feet, and its weight 10,100 tons; and such a mass would require a lateral pressure at the crown of the arch of about 7000 tons to overset it. Any strength of attachment to the abutments would, of course, make it still firmer, and any want of connexion between the parts weaker; and since the actual resistance to such a force must depend entirely on the strength of the oblique connexion between the ribs, it is not easy to define its magnitude with accuracy: but, as Professor Robison has justly remarked, the strength would be increased by causing the braces to extend across the whole breadth of the half arch. The single ribs, if wholly unconnected, might be overset by an inconsiderable force, since they stand in a kind of tottering equilibrium; and something like this appears to have happened to the bridge at Wearmouth. Dr Hutton, indeed, mentions some "diagonal iron bars" in this bridge; but these were perhaps added after its first erection, to obviate the "twisting," which had become apparent, since they are neither exhibited in the large plates of the bridge, nor mentioned in the specification of the patent.

QUESTION 7. *Supposing the span of the arch to remain the same, and to spring ten feet lower, What additional strength would it give the bridge? Or, making the strength the same, What saving may be made in the materials? Or, if, instead of a circular arch, as in the plates and drawings, the bridge should*

be made in the form of an elliptical arch, What would be the difference in effect, as to strength, duration, convenience, and expenses? Bridge.

The question seems to suppose the weight of the materials to remain unaltered, and the parts of the structure, that would be expanded, to be made proportionally lighter; which could not be exactly true, though there might be a compensation in some other parts. Granting, however, the weight to be the same under both circumstances, if the ordinate y at the end be increased in the proportion of 64 to about 73, the curvature at the vertex will be increased, and the lateral thrust diminished in the same ratio, the 9470 tons being reduced to 8300. The additional thrust occasioned by any foreign weight would also be lessened, but not the vertical displacement of the curve derived from its pressure; and since the whole fabric might safely be made somewhat lighter, the lightness would again diminish the strain. The very least resistance that can be attributed to a square inch of the section of a block of cast iron, is about 50 tons, or somewhat more than 100,000 pounds. It is said, indeed, that Mr William Reynolds found, by accurate experiments, that 400 tons were required, to crush a cube of a quarter of an inch, of the kind of cast iron called gun-metal, which is equivalent to 6400 tons for a square inch of the section. But this result so far exceeds any thing that could be expected, either from experiment or from analogy, that it would be imprudent to place much reliance on it in practice; the strength attributed to the metal being equivalent to the pressure of a column 2,280,000 feet in height, which would compress it to about four-fifths of its length, since the height of the modulus of elasticity (Prop. G.) is about 10,000,000 feet. The greatest cohesive force, that has ever been observed in iron or steel, does not exceed 70 tons for a square inch of the section, and the repulsive force of a homogeneous substance has not been found, in any other instance, to be many times greater or less than the cohesive. There cannot, however, be any doubt that the oblique thrust, which amounts to 10,730 tons, would be sufficiently resisted by a section of 215 square inches, or, if we allowed a load amounting to about one-third only of the whole strength, by a section of 600 square inches; and since each foot of an iron-bar, an inch square, weighs three pounds, and the whole length of the arch nearly a ton, the 600 square inches would require nearly as many tons to be employed in the ribs affording the resistance, upon this very low estimate of the strength of cast iron. The doubts here expressed respecting Mr Reynolds's results, have been fully justified by some hasty experiments, which have been obligingly made by the son of a distinguished architect: he found that two parallelepipeds of cast iron, one eighth of an inch square, and a quarter of an inch long, were crushed by a force of little more than a ton. The experiments were made in a vice, and required considerable reductions for the friction. The mode of calculation may deserve to be explained, on account of its utility on other similar occasions. Supposing the friction to be to the pressure

Bridge. on the screw as 1 to m , and the pressure on the screw to the actual pressure on the substance as n to 1, calling this pressure x , the pressure on the screw will be nx , and the friction $\frac{nx}{m}$; but this re-

sistance will take from the gross ultimate pressure f a force, which is to the friction itself, as the velocity of the parts sliding on each other is to the velocity of the part producing the ultimate pressure, a proportion which we may call p to 1; and the force remaining will be the actual pressure; that is,

$$f - \frac{pnx}{m} = x, \text{ and } x = \frac{m}{m+pn} f. \text{ In these experi-}$$

ments, the gross force f , as supposed to be exerted

on the iron, was 4 tons; the friction $\frac{1}{m}$, was probably

about $\frac{1}{3}$, the screw not having been lately oiled; the distance of the screw from the centre of motion was to the length of the whole vice as 3 to 4, whence n was $\frac{3}{4}$, and p was 8.44, the middle of the screw describing 4.22 inches, while the cheek of the vice

moved through $\frac{1}{2}$ an inch: consequently $\frac{m}{m+pn}$ was

$$\frac{4}{4+11.25} = \frac{1}{3.81}, \text{ and the corrected pressure be-}$$

comes $\frac{4}{3.81}$. In several experiments made with still

greater care, and with an improved apparatus of levers, the mean force required to crush a cube of a quarter of an inch was not quite $4\frac{1}{2}$ tons, instead of 400.

Calcareous freestone supports about a ton on a square inch, which is equal to the weight of that of a column not quite 2000 feet in height: consequently an arch of such freestone, of 2000 feet radius, would be crushed by its own weight only, without any further load; and for an arch like that of a bridge, which has other materials to support, 200 feet is the utmost radius that it has been thought prudent to attempt; although a part of the bridge of Neuilly stands, cracked as it is, with a curvature of 250 feet radius; and there is no doubt that a firm structure, well arranged in the beginning, might safely be made much flatter than this, if there were any necessity for it.

An elliptical arch would certainly approach nearer to the form of the curve of equilibrium, which would remain little altered by the change of that of the arch; and the pressure might be more equably and advantageously transmitted through the blocks of such an arch, than in the proposed form of the structure. The duration would probably be proportional to the increased firmness of the fabric, and the greater flatness at the crown might allow a wider space for the passage of the masts of large ships on each side of the middle. There might be some additional trouble and expense in the formation of portions of an elliptical curve; but even this might be in a great measure avoided by employing portions of three circles of different radii, which would scarcely be distinguishable from the ellipsis itself.

Those who have imagined that a circular arch

Bridge. must in general be "stronger than an elliptical arch of the same height and span," have not adverted to the distinction between the apparent curvature of the arch, and the situation of the true curve of equilibrium, which depends on the distribution of the weight of the different parts of the bridge, and by no means on the form of the arch-stones only; this form being totally insufficient to determine the true radius of curvature, which is immediately connected with the lateral thrust, and with the strength of the fabric.

QUESTION 8. *Is it necessary or advisable to have a model made of the proposed bridge, or any part of it, in cast iron. If so, what are the objects to which the experiments should be directed; to the equilibration only, or to the cohesion of the several parts, or to both united, as they will occur in the intended bridge?*

Experiments on the equilibration of the arch would be easy and conclusive; on the cohesion or connexion of the parts, extremely uncertain; the form and proportion of the joints could scarcely be imitated with sufficient accuracy; and since the strength of some of the parts concerned, would vary as the thickness simply, and that of others as the square or cube of the thickness, it would be more difficult to argue from the strength of the model upon that of the bridge, than to calculate the whole from still more elementary experiments. Some such experiments ought, however, to be made, on the force required to crush a block of the substance employed; and the form calculated to afford the proper equilibrium, might be very precisely and elegantly determined, by means of the method first suggested by Dr Hooke, that of substituting for the blocks, resting on each other and on the abutments, as many similar pieces forming a chain, and suspended at the extremities. It would, however, be important to make one alteration in the common mode of performing this experiment, without which it would be of little or no value; the parts corresponding to the blocks of the arch, should be formed of their proper thickness and length, and connected with each other and with the abutments by a short joint or hinge in the middle of each, allowing room for a slight degree of angular motion only; and every other part of the structure should be represented in its proper form and proportion and connexion, that form being previously determined as nearly as possible by calculation; and then, if the curve underwent no material alteration by the suspension, we should be sure that the calculation was sufficiently correct; or, if otherwise, the arrangement of the materials might be altered, until the required curve should be obtained; and the investigation might be facilitated by allowing the joints or hinges, connecting the block, to slide a little along their surfaces, within such limits as would be allowable, without too great a reduction of the powers of resistance of the blocks.

QUESTION 9. *Of what size ought the model to be made, and what relative proportions will experiments, made on the model, bear to the bridge when executed?*

The size is of little importance, and it would be unsafe to calculate the strength of the bridge from

Bridge.

any general comparison with that of the model. There is an *Essay* of Euler in the *New Commentaries of the Royal Academy of Petersburg* (Vol. XX. p. 271.), relating expressly to the mode of judging of the strength of a bridge from a model; but it contains only an elementary calculation, applicable to ropes and simple levers, and by no means comprehending all the circumstances that require to be considered in the structure of an arch.

QUESTION 10. *By what means may ships be best directed in the middle stream, or prevented from driving to the side, and striking the arch; and what would be the consequence of such a stroke?*

For the direction of ships, Professor Robison's suggestion seems the simplest and best, that they might be guided by means of a small anchor, dragged along the bottom of the river. The stroke of a ship might fracture the outer ribs, if they were too weak, but could scarcely affect the whole fabric in any material degree, supposing it to be firmly secured by oblique bars, crossing from one side of the abutment to the other side of the middle; and if still greater firmness were wanted, the braces might cross still more obliquely, and be repeated from space to space.

A ship moving with a velocity of three miles in an hour, or about four feet in a second, would be stopped by a force equal to her weight, when she had advanced three inches with a retarded motion; and the bridge could not very easily withstand, at any one point, a force much greater than such a shock of a large ship, if it were direct, without being dangerously strained. But we must consider that a large ship could never strike the bridge with its full force, and that the mast would be much more easily broken than the bridge. The inertia of the parts of the bridge, and of the heavy materials laid on it, would enable it to resist the stroke of a small mass with great mechanical advantage. Thus the inertia of an anvil, laid on a man's chest, enables him to support a blow on the anvil, which would be fatal without such an interposition, the momentum communicated to the greater weight being always less than twice the momentum of the smaller; and this small increase of momentum being attended by a much greater decrease of energy or impetus, which is expressed by the product of the mass into the square of the velocity, and which is sometimes called the ascending or penetrating force, since the height of ascent or depth of penetration is proportional to it, when the resistance is given. And the same mode of reasoning is applicable to any weight falling on the bridge, or to any other cause of vibration, which is not likely to call forth in such a fabric any violent exertion of the strength of the parts, or of their connections. We must also remember, in appreciating the effect of a stroke of any kind on an arched structure, that something of strength is always lost by too great stiffness; the property of resisting velocity, which has sometimes been called resilience, being generally diminished by any increase of stiffness, if the strength, with respect to pressure, remains the same.

QUESTION 11. *The weight and lateral pressure of the bridge being given, can abutments be made in the proposed situation for London Bridge, to resist that pressure?*

Since this question relates entirely to the local circumstances of the banks of the Thames, the persons, to whom it has been referred, have generally appealed to the stability of St Saviour's Church, in a neighbouring situation, as a proof of the affirmative. And it does not appear that there have been any instances of a failure of piles well driven, in a moderately favourable soil. Professor Robison, indeed, asserts that the firmest piling will yield in time to a pressure continued without interruption; but a consideration of the general nature of friction and lateral adhesion, as well as the experience of ages in a multitude of structures actually erected, will not allow us to adopt the assertion as universally true. When, indeed, the earth is extremely soft, it would be advisable to unite it into one mass for a large extent, perhaps as far as 100 yards in every direction, for such a bridge as that under discussion, by beams radiating from the abutments, resting on short piles, with cross pieces interspersed; since we might combine, in this manner, the effect of a weight of 100,000 tons, which could scarcely ever produce a lateral adhesion of less than 20,000, even if the materials were semifluid; for they would afford this resistance, if they were capable of standing in the form of a bank, rising only one foot in five of horizontal extent, which any thing short of an absolute quicksand or a bog would certainly do in perfect security. The proper direction of the joints of the masonry may be determined for the abutment exactly as for the bridge, the tangent of the inclination being always increased, in proportion to the weights of the successive wedges added to the load; and the ultimate inclination of the curve is that in which the piles ought to be driven; being the direction of the result, composed of the lateral thrust, combined with the joint weight of the half bridge, and the abutment.

QUESTION 12. *The weight and lateral pressure of the bridge being given, can a centre or scaffolding be erected over the river, sufficient to carry the arch, without obstructing the vessels which at present navigate that part?*

There seems to be no great difficulty in the construction of such a centre. When the bridge at Wearmouth was erected, the centre was supported by piles and standards, which suffered ships to pass between them without interruption, and a similar arrangement might be made in the present case with equal facility.

QUESTION 13. *Whether would it be most advisable to make the bridge of cast and wrought iron combined, or of cast iron only? And if of the latter, Whether of the hard white metal, or of the soft grey metal, or of gun metal?*

A bridge well built ought to require no cohesive strength of ties, as Mr Southern has justly observed in his answer to the eighth question; and for repulsive resistance, in the capacity of a shore, cast iron is probably much stronger than wrought. It has also the advantage of being less liable to rust, and of expanding somewhat less by heat than wrought iron. But wherever any transverse strain is unavoidable, wrought iron possesses some advantages, and it is generally most convenient for bolts and other fastenings. The kind of iron called gun metal, is decidedly preferred by the most experienced

Bridge. judges, as combining, in the greatest degree, the properties of hardness and toughness; the white being considered as too brittle, and the grey as too soft. Dr Hutton, however, and Mr Jessop, prefer the grey; and if we allow the strength of the gun metal to be at all comparable to that which Mr Reynolds attributes to it, we must also acknowledge that a much weaker substance would be amply sufficient for every practical purpose, and might deserve to be preferred, if it were found to possess a greater degree of tenacity.

QUESTION 14. *Of what dimensions ought the several members of the iron work to be, to give the bridge sufficient strength?*

See the Answers to Questions 7 and 11.

QUESTION 15. *Can frames of cast iron be made sufficiently correct to compose an arch of the form and dimensions shown in the drawings, so as to take an equal bearing as one frame, the several parts being connected by diagonal braces, and joined by an iron cement, or other substance?*

Professor Robison considers it as indispensable that the frames of cast iron should be ground to fit each other; and a very accurate adjustment of the surface would certainly be necessary for the perfect co-operation of every part of so hard a substance. Probably, indeed, any very small interstices that might be left, would in some measure be filled up by degrees, in consequence of the oxydation of the metal, but scarcely soon enough to assist in bearing the general thrust upon the first completion of the bridge. The plan of mortising the frames together is by no means to be advised, as rendering it very difficult to adapt the surfaces to each other throughout any considerable part of their extent. They might be connected either as in the bridge at Wearmouth, by bars of wrought iron let into the sides, which might be of extremely moderate dimensions; or, as in some still more modern fabrics, by being wedged into the grooves of cross plates, adapted to receive them, which very effectually secure the co-operation of the whole force of the blocks, and which have the advantage of employing cast iron only.

QUESTION 16. *Instead of casting the ribs in frames, of considerable length and breadth, would it be more advisable to cast each member of the ribs in separate pieces of considerable lengths, connecting them together by diagonal braces, both horizontally and vertically?*

No joint can possibly be so strong as a single sound piece of the same metal; and it is highly desirable that the curve of pressure should pass through very substantial frames or blocks, abutting fully on each other, without any reliance on lateral joints; but for the upper parts of the work, single ribs, much lighter than those which form the true arch, would be sufficiently firm.

QUESTION 17. *Can an iron cement be made, which shall become hard and durable, or can liquid iron be poured into the joints?*

Mr Reynolds has observed, that a cement, composed of iron borings and saline substances, will become extremely hard; and it is probable that this property depends on the solidity which is produced by the gradual oxydation of the iron. It would certainly be injurious to the strength of the fabric to

interpose this cement between perfectly smooth and solid surfaces; but it might be of advantage to fill up with it any small interstices, unavoidably left between the parts. To pour melted iron into the joints would be utterly impracticable.

QUESTION 18. *Would lead be better to use in the whole or any part of the joints?*

Lead is by far too soft to be of the least use; and a saline cement would be decidedly preferable.

QUESTION 19. *Can any improvement be made in the plan, so as to render it more substantial and durable, and less expensive? And if so, what are these improvements?*

The most necessary alterations appear to be the omission of the upper and flatter ribs; the greater strength and solidity of the lower, made either in the form of blocks or of frames with diagonals; a curvature more nearly approaching to that of the curve of equilibrium, and a greater obliquity of the cross-braces.

It would be necessary to wedge the whole structure very firmly together before the removal of the centres, a precaution which is still more necessary for stone bridges, in which a certain portion of soft mortar must inevitably be employed, in order to enable the stones to bear fully on each other, and which has been very properly adopted in the best modern works. In this manner we may avoid the inconvenience pointed out by Professor Robison, who has remarked, that the compressibility of the materials, hard as they appear, would occasion a reduction of three inches in the length of the bridge, from the effect of the lateral thrust, and a consequent fall at the crown of 15; a result which will not be found materially erroneous, if the calculation be repeated from more correct elements, derived from later experiments and comparisons. For obviating the disadvantageous effects of such a depression, which he seems to have supposed unavoidable, as well as those of a change of temperature, which must in reality occur, though to a less considerable extent, Professor Robison suggested the expedient of a joint in the middle of the bridge, with an intermediate portion, calculated to receive the rounded ends of the opposite ribs, somewhat like an interarticular cartilage; but it is impossible to devise any kind of joint, without limiting the pressure, during the change of form, to a very small portion of the surfaces, which could not bear fully on each other throughout their extent, if any such liberty of motion were allowed, unless all friction between them were prevented; and a similar joint would be required at the abutment, where it would be still more objectionable, as extending to a wider surface.

The arrangement of the joints between the portions of the ribs, in one or more transverse lines, would be a matter of great indifference. Some have recommended to break the joints, as is usual in masonry, in order to tie the parts more firmly together; others to make all the joints continuous, as a safer method, on account of the brittleness of the materials; but if the fabric were well put together, there would be neither any want of firm connexion, nor any danger of breaking from irregular strains, in whatever way the joints might be disposed.

QUESTION 20. *Upon considering the whole cir-*

Bridge.

Bridge.

circumstances of the case, agreeable to the Resolutions of the Committee, as stated at the conclusion of their Third Report, is it your opinion, that an arch of 600 feet in the span, as expressed in the drawings produced by Messrs Telford and Douglas, or the same plan, with any improvement you may be so good as to point out, is practicable and advisable, and capable of being made a durable edifice?

The answers that have been returned to this question are almost universally in the affirmative, though deduced from very discordant and inconsistent views of the subject. The only reasonable doubt relates to the abutments; and with the precautions which have been already mentioned in the answer to the 11th question, there would be no insuperable difficulty in making the abutments sufficiently firm.

QUESTION 21. Does the estimate, communicated herewith, according to your judgment, greatly exceed or fall short of the probable expense of executing the plan proposed: specifying the general grounds of your opinion?

The estimate amounts to L. 262,289; and it has generally been considered as below the probable expense. The abutments are set down at L. 20,000; but they would very possibly require five times as much, to be properly executed; while some other parts of the work, by a more judicious distribution of the forces concerned, might safely be made so much lighter, as considerably to lessen the expense of the whole fabric, without any diminution either of its beauty or of its stability.

SECTION VI.—Modern History of Bridges.

The whole series of the questions, which we have been considering, are fully as interesting at the present moment, as they were at the time when they were circulated by the Committee of the House of Commons. The practice of building iron bridges has been progressively gaining ground, ever since its first introduction, in 1779, by Mr Abiah Darby of Colebrook Dale. Mr Wilson, indeed, who assisted Mr Burdon in the erection of the bridge at Wearmouth, mentions in his answers, an iron bridge which has stood secure for ninety years: but it must have been on a very small scale, and has not been at all generally known. Of most of the later iron bridges we find a concise account in Dr Hutton's elaborate Essay on Bridges, which has been reprinted in the first volume of his valuable collection of Tracts: but there are some still greater edifices of this kind which still remain to be completed.

Mr Darby's construction is not remarkably elegant (Plate XLII. fig. 8.), but it is by no means so objectionable as several late authors have seemed to think it. The span is 100 feet 6 inches: the weight 178½ tons. The curvature of the exterior concentric arches, which assist in supporting the roadway, though it may be somewhat too great for the most favourable exertion of their resistance, leaves them still abundantly strong for the purpose intended; nor is it correct to say that every shore supporting a pressure should be straight; for if its own weight bears any considerable proportion to that which it has to support, the curvature ought to be the same with that

Bridge.

of a chain of the same weight, suspending a similar load in an inverted position: and the parts of the bridge in question seem to differ only about as much from such a form in excess of curvature, as a straight line would differ from it in defect. The partial failure, which accidentally occurred, rather bears testimony to the merits than to the demerits of the bridge, as they would be estimated in any other situation: for the lateral thrust, which it is generally desirable to reduce as much as possible, was here actually too small, and the abutments were forced inwards, by the external pressure of the loose materials, forming the high banks, against which the abutments rested.

Mr Paine's iron bridge, exhibited in London, and intended to have been erected in America, was a professed imitation of a catenarian curve: it was a good specimen of that ideal something, which a popular reformer generally has in view: a thing not ill imagined, and which might possibly succeed very well under very different circumstances; but which, when closely examined, proves to be wholly unfit for the immediate purpose to which the inventor intends to apply it.

The bridge at Wearmouth was completed in 1796, in great measure through the exertions of Mr Burdon, both as architect and as principal proprietor of the undertaking. It is remarkable for springing 70 feet above low water mark; and the arch rises 30 feet, leaving a height of 100 feet in the whole for the passage of ships in the middle of the stream; the span is 240. The abutments are founded on a solid rock, but their own internal solidity appears to be somewhat deficient. The weight of iron is 250 tons; 210 of them being of cast iron, and 40 of wrought. (Plate XLII, fig. 9.)

A bridge was finished in the same year at Buildwas, near Colebrook Dale (Plate XLII. fig. 10.), under the direction of Mr Telford; 130 feet in span, weighing 174 tons; and rising only 17 feet in the roadway, but furnished on each side with a stronger arch, of about twice the depth, which extends to the top of the railing, and assists in suspending the part of the road which is below it by means of king-posts; and in supporting the part nearer the abutments by braces and shores. The breadth is only 18 feet; and the construction would not be so easily applicable to a wider bridge, unless the road were divided in the middle by an additional elevated arch with its king-posts, like the celebrated wooden bridge at Schaffhausen, which was burnt down by one of the French armies. A third iron bridge was also erected in 1796 on the Parrot at Bridgewater, by the Colebrook Dale Company. It consists of an elliptic arch, of 75 feet span, and 23 feet height, and somewhat resembles the bridge at Wearmouth in the mode of filling the haunches with circular rings: a mode not very advantageous for obtaining the greatest possible resistance from the materials, and consequently throwing a little too much weight on the parts of the arch which support them; although it is probable that no great inconvenience has actually arisen from this cause.

An attempt was also made, about the same time, to throw an iron bridge over the river Tame in Herefordshire; but it fell to pieces as soon as the centre was removed. A similar failure occurred some time

Bridge. afterwards in a bridge of about 180 feet span, which was erected on the Tees at Yarm. In 1802 or 1803, an elegant iron bridge, of 181 feet span, and 16½ rise, was erected at Staines. Its general form resembled that of the bridge at Wearmouth, but the mode of connexion of the parts was somewhat different. In a short time after its completion, it began to sink, and some of the transverse pieces broke, in consequence of the change of form. Upon examination it was found that one of the abutments had given way: and when this was repaired and made firmer, the other failed. The abutment was pushed outwards horizontally, without any material derangement of its form or direction; a circumstance which could not have happened if its weight had been sufficiently great: but the architect seems to have trusted to the firmness of the iron, and the excellence of the workmanship, and to have neglected the calculation of the lateral thrust, which it is of so much importance to determine.

Mr Rennie has executed several iron bridges with success in Lincolnshire; one at Boston, over the Witham, of which the span is 86 feet, and the rise 5½ only: but the abutments being well constructed, it has stood securely, notwithstanding the fracture of some of the cross pieces of the frames, which had been weakened by the unequal contraction of the metal in cooling. At Bristol, Messrs Jessop erected two iron bridges, of 100 feet span, rising 15; each of them contains 150 tons of grey iron; and the expense of each was about L.4000. The construction appears to be simple and judicious. (Plate XLII. fig. 11.)

Mr Telford has been employed in the construction of several aqueduct bridges on a considerable scale. One of these was cast by Messrs Reynolds, and completed in 1796; near Wellington in Shropshire: it is 180 feet long, and 20 feet above the water of the river, being supported on iron pillars. Another, still larger, was cast by Mr Hazledine, for carrying the Ellesmere canal over the river Dee, at Pontcysyllte, in the neighbourhood of Llangollen. It is supported, 126 feet above the surface of the river, by 20 stone pillars, and is 1020 feet in length, and 12 feet wide. (Plate XLII. fig. 12.)

In France, a light iron bridge, for foot passengers only, was thrown across the Seine, opposite to the gate of the Louvre, in 1803. It is supported by stone piers, which are too narrow to withstand the effect of an accident happening to any part of the fabric, and leaving the lateral thrust uncompensated: nor is there any immediate reason to apprehend that any inconvenience should arise from this deficiency of strength; since it is highly improbable than any partial failure should occur, in such a situation, supposing the bridge originally well constructed. (Plate XLIII. fig. 1.)

But all these works have been far exceeded, in extent and importance, by the three new bridges, lately built and now building over the Thames. The Vauxhall Bridge was completed and opened in August 1816: it consists of nine arches of cast iron; each of 78 feet span, and between 11 and 12 feet rise. The breadth of the roadway is 36 feet clear. The architect was Mr Walker. The form of the arches considerably resembles that of Messrs Jessop's bridges at Bristol; but it is somewhat lighter and

more elegant, and it has the advantage of a greater solidity in the blocks supporting the principal part of the pressure. (Plate XLIII. fig. 2, 3.)

This advantage characterizes also very strongly the masterly design of Mr Rennie for the structure about to be erected at the bottom of Queen Street, Cheapside, opposite to Guildhall, under the name of the Southwark Bridge. It exhibits an excellent specimen of firmness of mutual abutment in the parts constituting the chief strength of the arch, which has been shown in this essay to be so essential to the security of the work, and which the architect has probably been in great measure induced to adopt from his practical experience of the comparative merits of different arrangements. A plan of the bridge was in February last made public in the Repository of Arts; a work which amply deserves the encouragement of all those who wish to promote the diffusion of useful information: and the magnitude of the object is such, as to justify our entering into some details of calculation respecting the pressure and strength of the different parts of the fabric; founded on a particular account of their weights and dimensions, which has not yet been made public: (Plate XLIII. fig. 4, 5, 6.)

An act of Parliament for the erection of this bridge was passed in 1811; but it was not begun till 1814; the act having directed that no operations should be commenced, until L. 300,000, out of the required L. 400,000, should be raised by subscription. The subscribers are allowed to receive ten per cent. annually on their shares, and the remainder of the receipts is to be laid by, and to accumulate, until it shall become sufficient to pay off to the proprietors the double amount of their subscriptions, and after this time the bridge is to remain open, without any toll. A considerable part of the iron work is already cast, by Messrs Walkers of Rotherham. The middle arch is to be 240 feet in span, the side arches 210 feet each. The abutment is of firm masonry, connected by dowels, to prevent its sliding; and resting on gratings of timber, supported by oblique piles. The piers stand on foundations nine or ten feet below the present bed of the river, in order to provide against any alterations which may hereafter take place in its channel, from the operation of various causes: and they are abundantly secured by a flooring of timber, resting on a great number of piles.

Weight of half of the middle arch of Southwark Bridge.

No.	s		3 Oblique Cross		Crosses.		Spandrils.		Total.
	Blocks.	Stays.	frames.						
	t. cwt.	t. cwt.	t. cwt.	t. cwt.	t. cwt.	t. cwt.	t. cwt.	t. cwt.	
1	62 18	2 11	11 0	9 1	26 4	111 17,			
2	60 19	2 12	10 13	8 15	20 3	103 4			
3	54 15	2 13	10 2	8 3	32 16	108 10.			
4	51 3	2 11	9 17		23 14	87 6			
5	50 17	2 13	9 15		32 14	95 19.			
6	51 2	2 13	9 15		24 15	88 6			
half 7	25 12	2 12			20 7	48 12			

(Carry forward.)

643 15

Bridge.

	Total t. wt.
(Brought forward,)	643 15
Covering-plates	152 0
Cornice and palisades	77 5
Roadway and pavement	650 0
<hr/>	
Whole weight	1523 0
Springing plate	13 10
Abutment	11,000 0
Span 240 feet. Rise 24. Depth of the blocks or plates at the crown 6 feet; at the pier 8 feet.	

It is evident from the inspection of this statement of the weights, that their distribution is by no means capable of being accurately expressed by any one formula; but it will be amply sufficient for the determination of the thrust, to employ the approximation founded on the supposition of a parabolic curve (Prop. T.); and if we afterwards wished to find the effect of any local deviation from the assumed law of the weight, we might have recourse to the mode of calculation exemplified in the answer to the fifth Question. But, in fact, that answer may of itself be considered as sufficient to show, that the effect of a variation of a few tons, from the load appropriate to each part, would be wholly unimportant.

We must, therefore, begin by finding the weight of a portion of the arch corresponding to a quarter of the span; and the whole angle, of which the tangent is $\frac{24}{120} = .2$, being $11^\circ 18\frac{1}{2}'$, its sine is .1961; and the angle, of which the sine is .09805, being $5^\circ 37\frac{1}{2}'$, we have to compute the weight of $\frac{337.5}{678.5}$, or

$\frac{1}{2.01}$, of the angular extent, beginning from the middle of the arch. And this will be $48 \frac{1}{2} + 88 \frac{5}{10} + 95 \frac{1}{2} + (87 \frac{5}{10}) \times .7345 = 297$ tons. Now, the weight of the covering-plates, cornice, palisades, roadway, and pavement, are distributed throughout the length, without sensible inequality, making 879 tons; from which the part immediately above the piers might be deducted; but it will be safer to retain the whole weight, especially as something must be allowed for the greater extent of the upper surface of the wedges. We shall, therefore, have, for the interior quarter, $297 + 439.5 = 736.5$ tons, and for the exterior $1523 - 736.5 = 786.5$, the difference being 50 tons; one-sixth of which, added to 736.5, gives us 744.8 for the reduced weight, which is to the lateral thrust as the rise to the half span. But for the rise we must take 23 feet, since the middle of the blocks next to the piers is a foot more remote from the intrados than that of the blocks at the crown. And the true half span, measured from the

same point, will be $4 \times \frac{120}{312}$ greater than that of the intrados, amounting to 121.6. We have, therefore, $23 : 121.6 = 745.8 : 3942$ tons, for m the lateral thrust.

And for $\frac{1}{2} ax$, $736.5 - \frac{50}{6} = 728.2$; whence, $\frac{1}{2} x$

being 60.8, $a = 11.98$, and $r = \frac{m}{a} = 329$ feet, the radius of curvature of the curve of equilibrium at the vertex, while that of the middle of the blocks is 334. In order to determine the ordinate y , we have $my =$

$\frac{1}{2} ax^2 + \frac{1}{12} bx^4$; but $\frac{1}{2} ax$ for the whole arch is 728.2 , and $\frac{1}{4} bx^3 = 50$; consequently $my = 728.2x + \frac{50}{3}x$, the first portion varying as x^2 , and the second as x^4 ; and the sum y being $23 = 22.49 + .51$, the ordinate at $\frac{1}{4} x$ or 30.4 feet is $\frac{1}{16} \times 22.49 + \frac{1}{256} \times .51 = 1.41$; and, in a similar manner, any other ordinate may be calculated, so that we have,

x .	y .	Middle of the Blocks.
30.2	1.41	1.40
60.8	5.65	5.67
91.0	13.02	12.89
121.6	23.00	23.00

Hence it appears that the curve of equilibrium nowhere deviates more than about two inches from the middle of the blocks, which is less than one fortieth of the whole depth.

The half weight of the smaller arches is probably about 1300 tons, and their lateral thrust 3500; and, since the abutment weighs 11,000 tons, the foundation ought to have an obliquity of $\frac{3500}{12300}$, or more

than 1 in 4, if it were intended to stand on the piles without friction; but in reality it rises only 66 inches in 624, or nearly 1 in 9; so that there is an angular difference of 1 in 7 between the direction of the piles and that of the thrust, which is probably a deviation of no practical importance.

It remains to be inquired how far the series of masses of solid iron, constituting the most essential part of the arch, is well calculated to withstand the utmost changes of temperature that can possibly occur to it in the severest seasons (Prop. K.) For this purpose, we may take the mean depth $a = 7$ feet,

h being 23; then $1 + \frac{4h}{a} = \frac{99}{7} = 14.14$, and $1 +$

$\frac{16hh}{15aa} = \frac{9199}{735} = 12.52$: consequently the greatest ac-

tual compression or extension of such a structure is to the mean change which takes place in the direction of the chord, as 14.14 to 12.52, or as 1.129 to 1; and if, in a long and severe frost, the temperature varied from 52° to 20° , since the general di-

mensions would contract about $\frac{1}{5000}$, the extreme

parts of the blocks near the abutments would vary $\frac{1.129}{5000}$ of their length; and the modulus M being

Bridge. about 10,000,000 feet, this change would produce a resistance equivalent to the weight of a column of the same substance 2258 feet high: that is, to about three tons for each square inch, diminishing gradually towards the middle of the blocks, and converted on the other side into an opposite resistance: so that this force would be added to the general pressure below in case of contraction, and above in case of extension. Now, the lateral thrust is derived from a pressure equivalent to a column about 329 feet high, of materials weighing 1523 tons, while the blocks themselves weigh 357; that is, to a column equal in section to the blocks, and 1400 feet high: it will, therefore, amount to about two tons on each square inch: consequently such a change of temperature, as has been supposed, will cause the extreme parts of the abutments to bear a pressure of five tons, where, in the ordinary circumstances, they have only to support two.

The ingenious architect proposes to diminish this contingent inconvenience, by causing the blocks to bear somewhat more strongly on the abutments at the middle than at the sides, so as to allow some little latitude of elevation and depression, in the nature of a joint: and, no doubt, this expedient will prevent the great inequality of pressure which might otherwise arise from the alternations of heat and cold. But it cannot be denied that there must be some waste of strength in such an arrangement, the extreme parts of the abutments, and of the blocks near them, contributing very little to the general resistance; and when we consider the very accurate adjustment of the equilibrium throughout the whole structure, we shall be convinced that there is no necessity for any thing like so great a depth of the solid blocks, especially near the abutments; and that the security would be amply sufficient if, with the same weight of metal, they were made wider in a transverse direction, preserving only the form of the exterior ones on each side, if it were thought more agreeable to the eye. In carpentry, where there is often a transverse strain, and where stiffness is frequently required, we generally gain immensely by throwing much of the substance of our beams into the depth; but in a bridge perfectly well balanced, there is no advantage whatever from depth of the blocks: we only want enough to secure us against accidental errors of construction, and against partial loads from extraneous weights; and it is not probable that either of these causes, in such a bridge, would ever bring the curve of equilibrium six inches, or even three, from its natural situation near the middle of the blocks.

We cannot conclude our inquiries into this subject with a more striking example, than by applying the principles of the theory to the magnificent edifice which is now nearly finished, by the same judicious and experienced architect, and which is destined to bear the triumphant appellation of Waterloo Bridge; a work not less pre-eminant among the bridges of all ages and countries, than the event which it will commemorate is unrivalled in the annals of ancient or modern history. It consists of nine elliptical arches, each of 120 feet span, and 35 feet rise. The piers are 20 feet thick, the road 28 feet wide, be-

sides a foot pavement of seven feet on each side. **Bridge.** The arches and piers are built of large blocks of granite, with short counterarches over each pier. The haunches are filled up, as is usual in the most modern bridges, by spandrils, or longitudinal walls of brick, covered with flat stones, and extending over about half the span of the arch; the remainder being merely covered with earth or gravel, which is also continued over the stones covering the spandrils. The hollow spaces between the walls are carefully closed above, and provided with outlets below, in order to secure them from becoming receptacles of water, which would be injurious to the durability of the structure. The mean specific gravity of the materials is such, that a cubic yard of the granite weighs exactly two tons, of the brick work one ton, and of the earth a ton and an eighth. Hence, the weight of the whole may be obtained from the annexed statement. (Plate XLIV. fig. 1, 2, 3.)

Contents of the materials in half an arch of Waterloo Bridge, from the middle of the pier to the crown, beginning from the springing of the arch.

	Cubic Feet.
Half of the arch stones, -	25311
Half of the inverted arch, -	2555
Square spandril between them, -	1994
Outside spandril walls, -	4374
Spandrils of brick, -	4976 (=2489)
Kirbels of the brick spandrils, -	1271
Flat stone covers, -	969
Earth, -	10260 (=5771)
Foot pavement, -	620
Frises, E. and W. -	1586
Cornice, E. and W. -	1120
Plinth of balustrade, -	510
Solid in parapet, -	416
Balusters 72, 151 cwt. -	102
Coping, E. and W. -	142

From this statement, and from a consideration of the arrangement of the materials, exhibited in the plate, we may infer that the half arch, terminated where the middle line of the arch-stones enters the pier, is equivalent in weight to about 34,000 cubic feet of granite; its inner half containing in round numbers 13,000, and its outer 21,000, whence we have 14,833 for the reduced weight of the quarter arch (Prop. T.). The extreme ordinate will be about 21 feet; the middle of the blocks being somewhat more than 16 feet above the springing of the arch, and the key-stone being four feet six inches deep; consequently the horizontal thrust will be

expressed by $14,833 \times \frac{60}{21} = 40,952$ cubic feet,

weighing 3033 tons. But $\frac{1}{2}ax$ being 11667, and

$\frac{1}{2}x = 30$, $a = 389$, and $\frac{m}{a} = r = \frac{40952}{388} = 105$

feet; while the radius of curvature of the ellipsis at

the crown is $\frac{60 \times 60}{35} = 103$ feet. It is obvious,

Bridge
Brisson.

therefore, that the curve of equilibrium will pass everywhere extremely near to the middle of the blocks, and there can be no apprehension of any deficiency in the equilibrium. It is true that, as it approaches to the piers, it acquires an obliquity of a few degrees to the joints; but the disposition to slide would be abundantly obviated by the friction alone, even if the joints were not secured by other precautions.

In building the arches, the stones were rammed together with very considerable force, so that, upon the removal of the centres, none of the arches sunk more than an inch and a half. In short, the accuracy of the whole execution seems to have vied with the beauty of the design, and with the skill of the arrangement, to render the Bridge of Waterloo a monument, of which the metropolis of the British Empire will have abundant reason to be proud, for a long series of successive ages.

EXPLANATION OF THE PLATES.

Plate XLII. fig. 1. If AB represent the distance of any two particles of matter, and BC, DE, FG the repulsive forces at the distances AB, AD, AF respectively, and BC, DH, FI, the corresponding cohesive forces, then GI must be ultimately to EH as FB to BD. (Sect. I. Prop. A.)

Fig. 2. The block will support twice as great a pressure applied at A as at B. (Prop. B.)

Fig. 3. It is obvious that $ABC = ADE = ABC - CFG$, HI being $= HK$, and $HG = HA$; and the difference $ABFHA$ is always equal to $DB \times KH$. (Prop. C.)

Fig. 4. It is evident that AB is to CD as AE to CE, or as $x + \frac{1}{2}x$ to x . (Prop. E.) It is also obvious that as x or CE is to CD, so is EF to FG. (Prop. F.)

Fig. 5. Supposing the arch AB to be so loaded in the neighbourhood of C as to require the curve of equilibrium to assume the form ADCEB, the

joints in the neighbourhood of D will be incapable of resisting the pressure in the direction of the curve CD, and must tend to turn on their internal terminations as centres, and to open externally. (Prop. Y.)

Fig. 6. A, B, C, Different steps in the fall of a weak arch. (Prop. Y.)

Fig. 7. Elevation and plan of Mess. Telford and Douglas's proposed iron-bridge over the Thames. (Sect. V.)

Fig. 8. Elevation of Mr Darby's iron Bridge at Colebrook Dale. (Sect. VI.)

Fig. 9. Elevation of Mr Burdon's Bridge at Wearmouth. (Sect. VI.)

Fig. 10. Elevation of Mr Telford's Bridge at Buildwas. (Sect. VI.)

Fig. 11. Elevation of Messrs Jessop's Bridges at Bristol. (Sect. VI.)

Fig. 12. Elevation of Mr Telford's Aqueduct Bridge at Pontcysylte. (Sect. VI.)

Plate XLIII. Fig. 1. Elevation of the Bridge of the Louvre at Paris. (Sect. VI.)

Fig. 2. Elevation of Vauxhall Bridge. (Sect. VI.)

Fig. 3. Middle arch of Vauxhall Bridge. (Sect. VI.)

Fig. 4. Middle arch of Southwark Bridge. (Sect. VI.)

Fig. 5. Elevation of Southwark Bridge. (Sect. VI.)

Fig. 6. Plan of Southwark Bridge. (Sect. VI.)

Fig. 7. Elevation of London Bridge in its present state. (Sect. IV.)

Fig. 8. Plan of London Bridge, with its sterlings. (Sect. IV.)

Fig. 9. London Bridge, as proposed by Mr Dance to be altered.

Plate XLIV. Fig. 1. Elevation of Waterloo Bridge (Sect. VI.)

Fig. 2. Plan of Waterloo Bridge. (Sect. VI.)

Fig. 3. Section of an arch of Waterloo Bridge, showing the foundations of the piers, and the spandril walls of brick; together with the centre supporting it. The dotted line represents the direction of the curve of equilibrium. (Sect. VI.) (O. R.)

BRISSON (MATHURIN JAMES), a zoologist and natural philosopher, born at Fontenay le Comte, 3d April 1723, the son of Mathurin Brisson and Louisa Gabrielle Jourdain.

He was originally intended for the church, but he had acquired at an early age a taste for natural history, which was particularly encouraged by the advantage that he enjoyed of passing his holidays with the justly celebrated Réaumur, who had an estate near Fontenay. At the age of twenty-four, he had made great progress in his theological studies, and had fully qualified himself for the rank of a subdeacon; but his courage failed him at the time appointed for taking orders, and he then determined to confine himself to the study of physical sciences. Réaumur had the direction of the Chemical Laboratory of the Academy of Sciences, and had given up the salary attached to it to several young men in succession, whom he appointed as his assistants, and of whom Pitot and Nollet became afterwards the most

distinguished. He now chose Brisson for the situation, which served him, as it had done his predecessors, rather as a step in his advancement with respect to general science, than in enabling him to pursue any objects more immediately chemical; and he followed his passion in attaching himself, almost exclusively, to natural history. The collection of Réaumur furnished him with ample materials for his studies, and with the principal subjects described in his works on the *Animal Kingdom*. The first of these was published in 1756, containing quadrupeds and cetaceous animals. It consists of simple descriptions of the different species, together with synonyms in various languages, more in the nature of a prodomus than of a complete history. His *Ornithologie* appeared in 1760, forming six volumes, and containing a number of well-executed plates. But upon Réaumur's death, the collection having been added to the Royal Cabinet, Messrs Buffon and Daubenton, the Directors of that Cabinet, not affording him all

Bridge
Brisson.

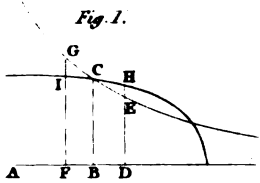

Fig. 2.

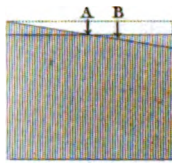

Fig. 3.



Fig. 5.

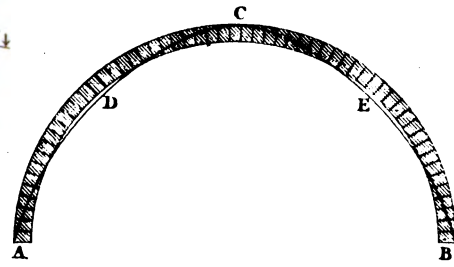

Fig. 4.

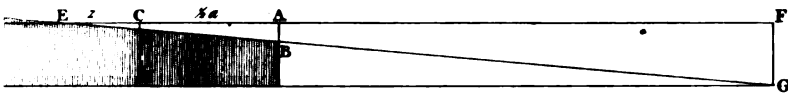
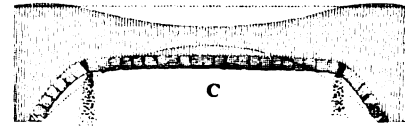
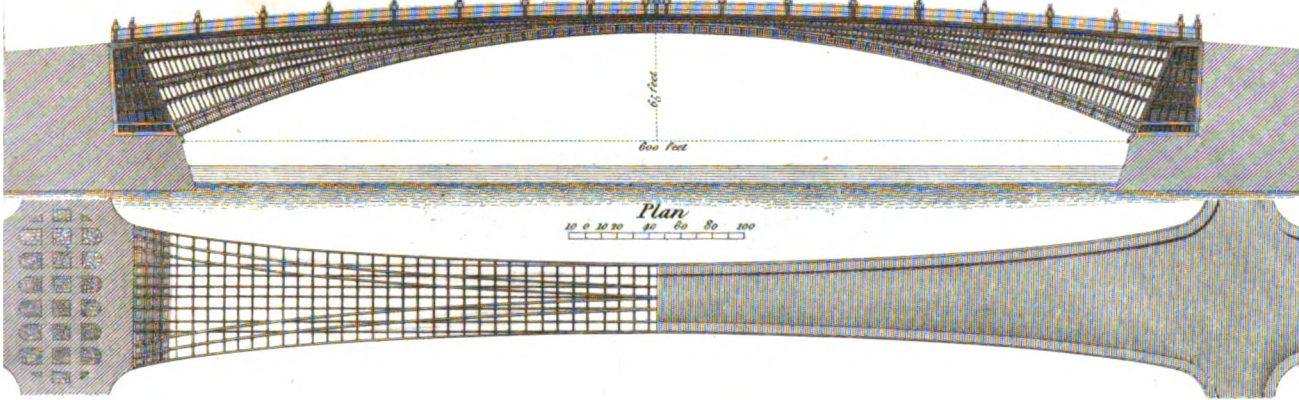

Fig. 6.



BRIDGE PROPOSED BY MESS: TELFORD AND DOUGLASS.

Fig. 7.



COLEBROOK DALE

Fig. 8.

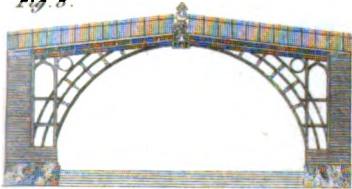

WEARMOUTH

Fig. 9.

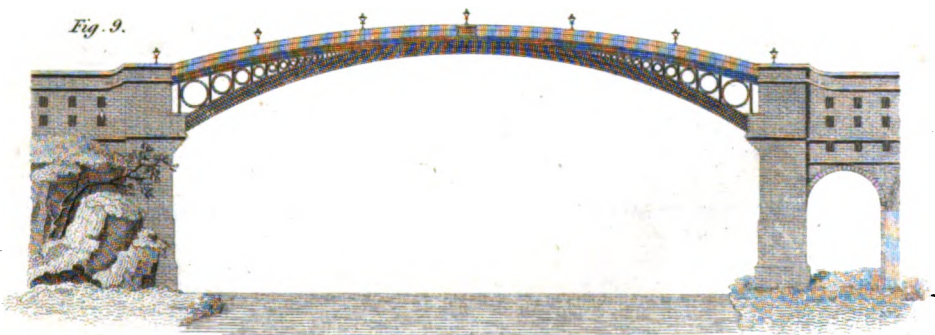

BUILDWAS

Fig. 10.

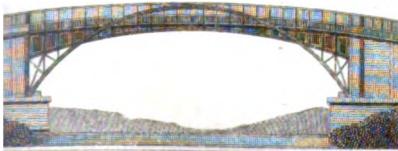

BRISTOL

Fig. 11.

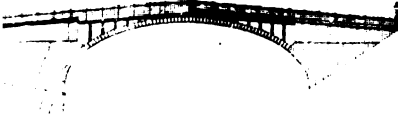

PONTCYSYLLE

Fig. 12.



BRIDGE.

BRIDGE OF THE LOUVRE

Fig. 1.

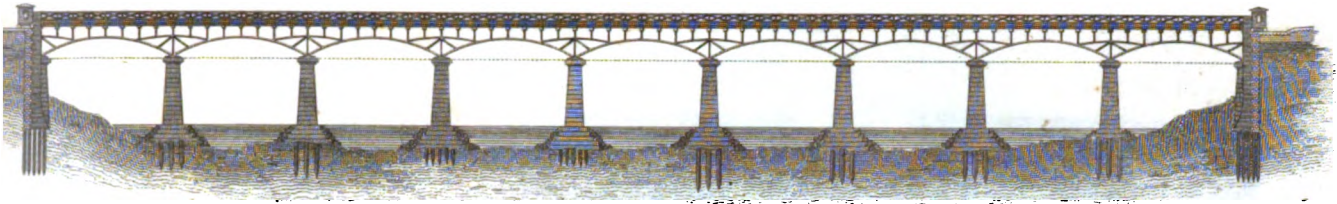

Fig. 2.

VAUXHALL



0 10 20 30 40 50 60 70 80 90 100 feet

Fig. 3.

MIDDLE ARCH



0 10 20 30 40 50 feet

Fig. 4.

SOUTHWARK MIDDLE ARCH

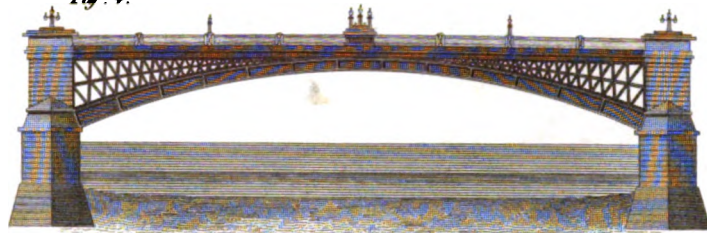

0 10 20 30 40 50 60 70 80 90 100 feet

Fig. 5.

SOUTHWARK



Fig. 6.

Plan

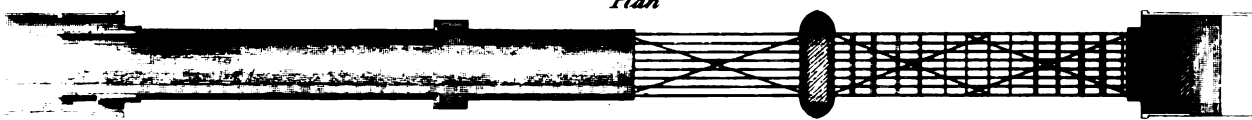

Fig. 7.

LONDON BRIDGE



Fig. 8.

Plan

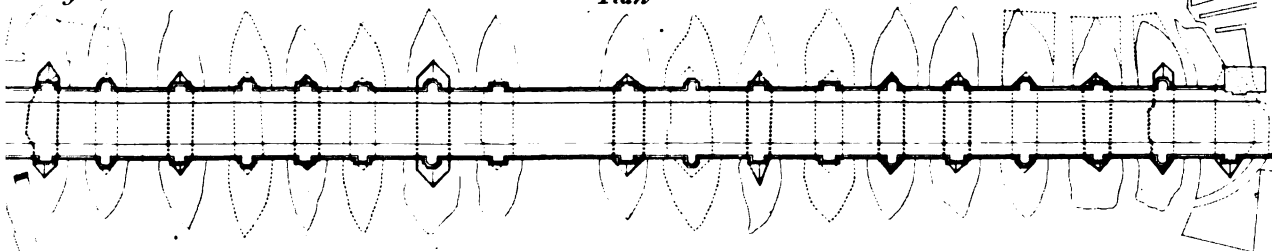

0 50 100 150 200 250 300 350 400 450 500 feet

PROPOSED IMPROVEMENTS

Fig. 9.



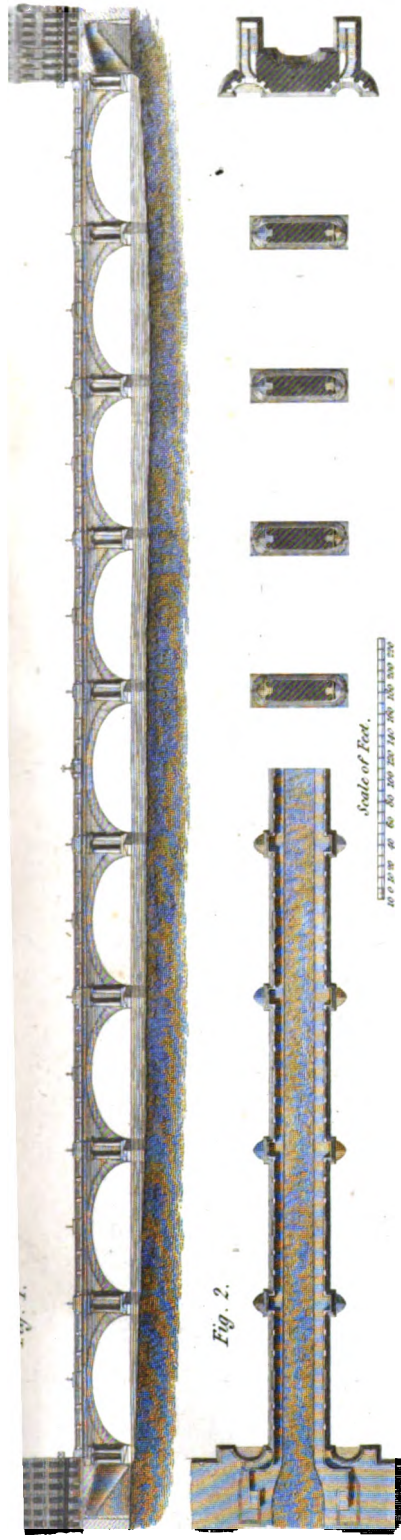

Fig. 2.

SECTION OF AN ARCH, WITH THE CENTRE.

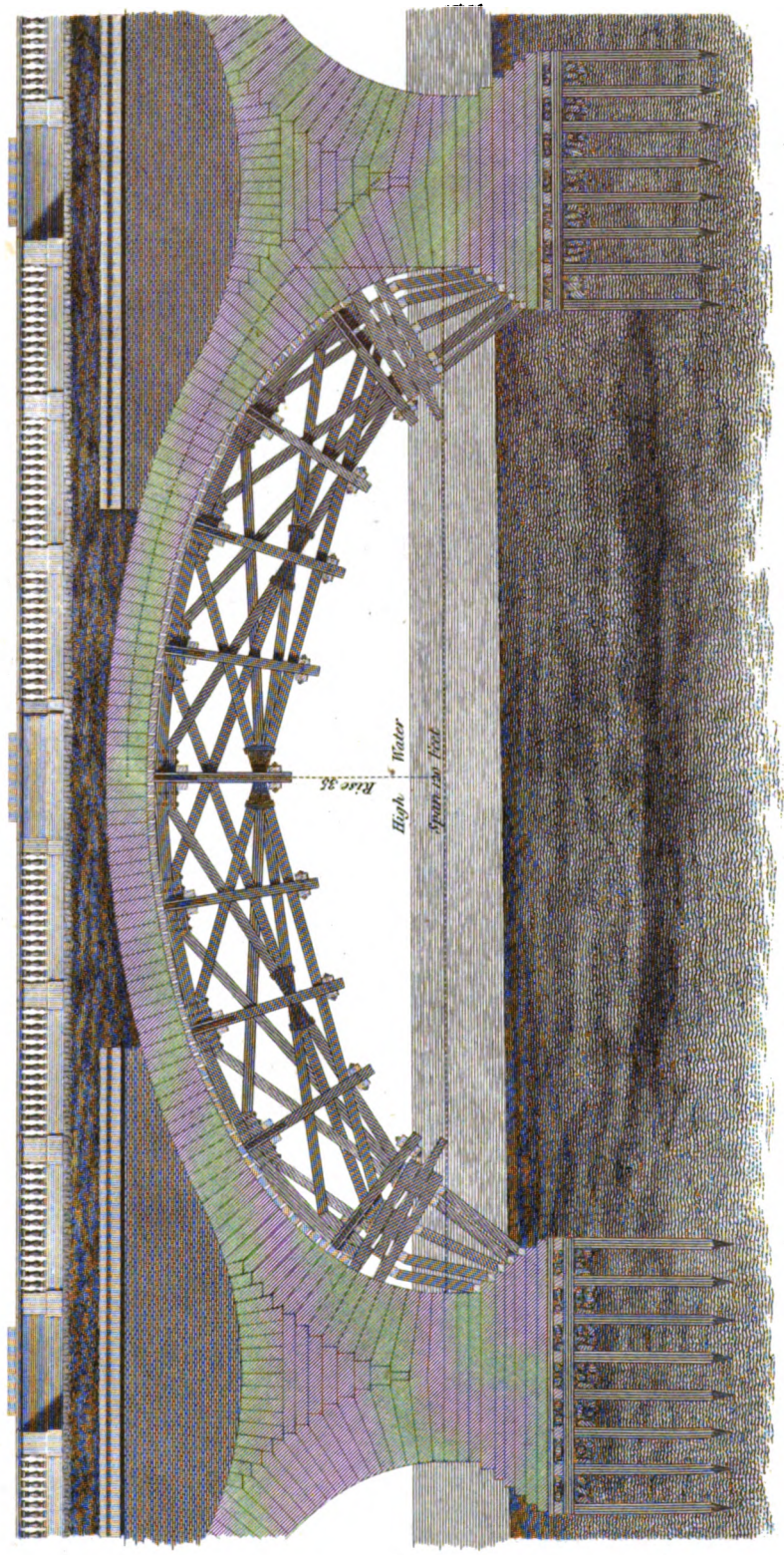

Fig. 3.

Engraved by E. Turrell.

Published by A. Constable & Co. Edinb 1817.

Brisson: the accommodations that he expected, he discontinued the work, and altogether renounced the study of natural history in favour of natural philosophy.

M. Brisson had been chosen a Member of the Academy of Sciences in 1759: he soon afterwards associated himself with the Abbé Nollet in delivering lectures on experimental physics, and obtained the reversion of his appointments of Professor in the College of Navarre, and Instructor of the royal family in Natural Philosophy and Natural History. The subject of electricity was at this time warmly debated between Nollet and Franklin; and M. Brisson had a difficult task to perform, in discussing the merits of a mistaken friend and an overbearing opponent; but, in fact, this department of science was at that time too little understood to make it disgraceful for Nollet to be in error with respect to the utility of conductors, or for Brisson to remain neuter upon this and other similar questions. He seems, however, by no means to have adhered to the character of neutrality in his anonymous *Translation of Priestley's History of Electricity*, published in 1771, and accompanied by notes, which exhibit a spirit of acrimonious criticism, not at all calculated to enhance the merit of the work, which he wished to introduce to the notice of his countrymen. He also attempted, in an *Essay on Water-spouts*, published in the Memoirs of the Academy, to explain a variety of electrical phenomena, by means of the different currents of fluid imagined by Nollet, but certainly with very little success.

He afterwards undertook a course of experiments on the *Specific Gravity of Alcohol and Water*, mixed in different proportions, which led him to a conjecture, at that time somewhat singular, that water was not a homogeneous substance. He assisted M. Trudaine, and other observers, in the experiments which they made on *Heat and Light* with the powerful lens of Bernière; and, in conjunction with M. Cadet, he endeavoured to disprove the opinion of Beccaria, that electricity has a power of reviving the *Metallic oxyds*. He also made experiments on the *Refractive powers* of fluids which might be substituted for flint glass, in the object glasses of telescopes; on the utility of different kinds of *Steel for magnetic purposes*; and on the mode of renewal of the *Shells of some species of Snails*.

In 1772, M. Brisson published a memoir on the *Specific Gravities of Metals*, a subject which, in all its extent, occupied a great portion of his attention during twenty years of his life. The results of his experiments, on a great variety of substances, were collected into a single volume of *Tables of Specific Gravities*, which was published in 1787. It was principally for the use of students who attended his lectures, that he published his *Traité de Physique*, and his *Dictionnaire*; both of them containing elementary and popular information, rather calculated exclusively for the immediate purpose which they were intended to serve, than for being of permanent utility in the promotion of the sciences. At a late period of his life, he renewed his attention to the subject of chemistry, when the discoveries of his junior contemporaries had given greater certainty and precision to its laws; and his last work was an *Ele-*

VOL. II. PART II.

mentary Treatise on that science, intended for the use of his pupils in the central school.

His whole life was occupied in his studies, and the history of his various works comprehends the history of every thing that is to be recorded concerning him. After eighty years of uninterrupted activity of mind, an attack of apoplexy reduced him to a state of second childhood, and effaced from his memory even all traces of his native language, except a few words of the dialect of Poitou, which he had spoken when he was a boy. He died the 23d June 1806; and his place in the Academy was filled by M. Gay Lussac. (*Delambre, Mém. Inst. Par. VII. Hist. p. 199.*) (T. U.)

BRISOT (JOHN PETER), the chief of the *Brisotine* or pure republican party in France, during the early stages of the Revolution, was born at the village of Ouarville, near Chartres, in the Orleannois, on the 14th of January 1754. His father, who was a pastry-cook, gave his son a liberal education, and Brisot became an author when he had scarcely left College. He exhibited a decided predilection for politics, and displayed an early zeal for republican principles. The boldness of his writings against the inequality of ranks excited the displeasure of the Government, and subjected him to a prosecution and imprisonment in the Bastile. Having been restored to liberty through the influence of the Duke of Orleans, at the solicitation of Mad. de Genlis, he married one of the Duchess's women, and soon afterwards went to England, with secret instructions, it is said, from the Lieutenant of the police. Others assert that he came over to London, to avail himself of the freedom of the press in conducting a periodical publication, the design of which was to enlighten the people of France on the subject of civil liberty. It is certain that he endeavoured to maintain himself in London by his literary talents; but the failure of this attempt subjected him to embarrassments from which he was relieved by the liberality of a friend, and he then returned to his native country.

Having again rendered himself obnoxious to the government by an attack on the administration of the Archbishop of Sens, he escaped a second imprisonment by a journey to Holland. During a temporary residence at Mecklin, he published a periodical paper, called *Le Courier Belgique*. In the beginning of the year 1788, he repaired to America; but, on the approach of the revolution, he returned to Paris, resolved to take an active part in the scenes which were just preparing. He commenced his revolutionary career in 1789, by the publication of some pamphlets, and particularly of a Journal, entitled *Le Patriote François*. He belonged to the *Representation des Communes*, which was formed in the capital a short time previous to the memorable 14th of July. On the storming of the Bastile, the keys were deposited with him. He was elected President of the Jacobin Club; and, in consequence of his zeal and activity in the revolutionary cause, he was appointed by his colleagues a Member of the *Comité des Recherches*, which served as the model of all those Committees which were afterwards successively formed, under similar denominations, and with similar objects; such as the *Comités de Surveil-*

Brisson
Brisot.

Brissot. lance, de Sureté Generale, de Salut Public, &c. Of this Committee Brissot was the president; and, while in this situation, he acquired a number of enemies. A French writer of the name of Morande published at Paris, in 1791, a periodical pamphlet, under the title of *Argus*, in which he assailed the character of Brissot with great bitterness, representing his conduct in the most odious colours, and even accusing him of robbery,—an accusation which, there is reason to believe, was utterly calumnious.

On the flight of the royal family, in 1791, Brissot, in concert with the Chevalier de Laclos, drew up the famous petition of the *Champ de Mars*, demanding the abdication of the king, which became the signal for a dangerous insurrection, that was with difficulty quelled, by the interposition of the National Guard. This circumstance is said to have been the occasion of his quarrel with M. de Lafayette, to whom he had previously been zealously attached. At this period, the republican faction began to assume a consistent form, and to utter their sentiments with freedom and boldness. Brissot, who had been one of its first and most zealous apostles, was returned a Member to the National Assembly, in spite of the opposition of the Court, to whom he had become extremely formidable; and from this time he displayed an implacable enmity to the king. The National Assembly, attributing to Brissot talents which he does not appear to have possessed, appointed him a Member of the Diplomatic Committee, of which he became the habitual organ; and in this capacity he was the constant advocate of the most violent public measures, and never ceased to demand a declaration of war against all the powers of Europe. In order to attain this object, it was necessary to remove the ministers, whose dispositions were favourable to peace. Brissot, accordingly, attacked them all, but particularly M. Delessart, who was at the head of the department of foreign affairs; and, by repeated denunciations, he at length succeeded in obtaining a decree of accusation against him. His place was supplied by Dumouriez, under whose administration war was declared against the Emperor of Germany, on the 20th of April 1792. From this period, however, the political influence of Brissot began to decline. Robespierre, with whom he had previously been intimately connected, now declared himself his enemy, denounced him at the Jacobin Club as a traitor to his country, and an enemy of the people, and continued to persecute him with unrelenting rancour, until he finally effected his destruction. Alarmed at the storm which was gathering around him, Brissot, in concert with the other leaders of his party, attempted to form a reconciliation with the constitutional royalists; but this attempt having proved abortive, he reverted to his former opinions and line of conduct, and continued to denounce to popular vengeance all those whom he knew to be attached to the king. But although his writings may naturally be supposed to have excited those dispositions among the people which gave rise to the atrocities of the times, he had no direct influence on the revolution of the 10th of August, which appears to have been planned and directed by Danton, and the ferocious leaders

of the Orleans faction. He was chosen a Deputy to *Brissot.* the National Convention for the department of the Eure, where he played only an inferior part, and was continually exposed to the rancorous attacks of Robespierre. It was Brissot, however, who, as the organ of the diplomatic committee, obtained the declaration of war against England and Holland, on the 1st of February 1793. This may be considered as the last act of his political life; for, from thenceforth, he was only occupied in defending himself against his numerous enemies.

The party distinguished by the name of the *Mountain* had now acquired a complete ascendancy, and meditated the destruction of their opponents, the *Girondists*, to which latter party Brissot was attached. Having at length been proscribed, after the revolution of the 31st of May, he was arrested at Moulins, while attempting to make his escape into Switzerland, sent to Paris, subjected to a mock-trial before the revolutionary tribunal, and beheaded on the 31st of October 1793, at the age of thirty-nine.

Brissot was somewhat below the middle size, a little deformed, and of a feeble constitution. His countenance was pale and melancholy, and he affected an extreme simplicity in his dress. With regard to his intellectual character, his talents appear to have been much beneath his reputation, and he certainly possessed more zeal than judgment. Notwithstanding, however, the violence of his writings, declamations, and public conduct, he was not deficient in humanity; and, in the intercourse of private life, his manners are said to have been mild and accommodating. As an author, Brissot has not much merit; his style is monotonous, verbose, and tedious; and, upon the whole, it is wonderful, that, with such slender abilities, he should have acquired so great an ascendancy in public opinion. The best articles of his journal are said to have been written by his secretary, Dupré. The following are the principal productions of his pen:

1. *Moyens d'Adoucir la Rigueur des Lois Penales en France*, Chalons, 1781, 8vo.
2. *Un Independant de l'Ordre des Avocats sur la Decadence du Barreau en France*, 1781, 8vo.
3. *De la Vérité, ou Meditations, &c.* 1782, 8vo.
4. *Le Philadelpbien à Geneve*, 1783, 8vo.
5. *Theorie des Lois Criminelles*, 1781, 2 vols. 8vo.
6. *Bibliothèque Philosophique du Legislateur, du Politique, du Jurisconsulte*, 1783-1786, 10 vols. 8vo.
7. *Tableau de la Situation Actuelle des Anglais dans les Indes Orientales, &c.* 1784-85, 8vo.
8. *Journal du Lycée de Londres, &c.* published in monthly numbers, 1784, 8vo.
9. *Un Défenseur du Peuple à l'Empereur Joseph II.; sur son Règlement concernant l'Emigration, &c.* 1785, 12mo.
10. *Examen Critique des Voyages dans l'Amerique Septentrionale, par le Marquis de Chatellus*, 1786, 8vo.
11. *Voyages en Europe, en Asie, et en Afrique*, translated from the English, with notes, 1786, and 1790, 2 vols. 8vo.
12. *Nouveau Voyage dans les Etats-Unis de l'Amerique Septentrionale*, 1791, 3 vols. 8vo.

To the first volume of this work was prefixed the life of Brissot, which was translated into English, and published separately in 1794. Besides these works, Brissot wrote a variety of pamphlets, and

articles inserted in periodical publications, which it is unnecessary to enumerate. See the Life of Brissot, above-mentioned, and the *Biographie Universelle*.
 Brissot
 Brocklesby.

BRITAIN. The history of ENGLAND and SCOTLAND is given under these separate heads in the *Encyclopædia*, down to the Union of the Crowns in the person of James VI.; from which period the history of the two countries is brought down to the rupture of the peace of Amiens, under the article BRITAIN. In order to afford more time to digest a comprehensive account of the great and important events which have succeeded, and of which Britain was the prime mover, we shall defer the continuation of the history till we reach the word ENGLAND.

BROCKLESBY (RICHARD), a Physician of considerable reputation, was born in Somersetshire, on the 11th of August 1722; and was descended from a respectable and opulent Irish family, belonging to the sect of Quakers. He received his grammatical education at the Academy of Ballymore, in the north of Ireland, and afterwards pursued his medical studies at Edinburgh, and at Leyden; at which latter University he graduated, in 1745, choosing for the subject of his thesis, *De Saliva sana et morbosa*. In the following year, he fixed his residence in London, with a view to practice; and in 1751 was admitted a Licentiate of the Royal College of Physicians, of which he afterwards became a fellow; after having received honorary degrees of Doctor in Medicine from the Universities of Dublin and of Cambridge. The first publication by which he became known to the world, was his *Essay on the Mortality of the Horned Cattle*, which appeared in 1746, and gained him considerable reputation; and his practice extended itself with that gradual and steady progress, which affords the surest prospect of permanent and distinguished success. His benevolent attention to his poorer patients, and the general suavity of his manners, soon brought him into notice, and procured him the esteem of a wide circle of friends, especially among his professional brethren. In consequence of their recommendation of him to Lord Barrington, he was appointed, in 1758, Physician to the Army; in which capacity he served in Germany during the greater part of the seven years' war; and in the course of it was chosen Physician to the Hospitals for British Forces. The results of his observations during this period were published in 1764, under the title of *Economical and Medical Observations, from 1738 to 1763, tending to the improvement of Medical Hospitals*, in one volume 8vo. He had already, however, given to the public many proofs of the activity of his mind, and the variety of his attainments. The *Transactions of the Royal Society* for 1747 (Vol. XLIV.) contain a letter of his *On the Indian Poison sent over by Don Antonio de Ulloa*; and the succeeding volume for 1747-8, a paper *On the Poisonous Root lately found mixed with the Gentian*. In the *Transactions* for 1755 (Vol. XLIX.) are inserted his *Experiments on the Sensibility and Irritability of the several parts of Animals*. He also published, in different volumes of the *Medical Observations*, the following papers, viz. *The Case*

of a Lady labouring under Diabetes, in Vol. III.—*Experiments relative to the Analysis of Seltzer Water*; and *Case of an Encysted Tumour in the Orbit of the Eye*; in Vol. IV. His *Dissertation on the Music of the Ancients* appeared in 1749; and his *Oratio Harveiana* in 1760. Brocklesby.

Dr Brocklesby was appointed, by his patron and friend the Duke of Richmond, Physician-General to the Royal Regiment of Artillery and Corps of Engineers; an appointment that connected him much with the laboratory of Woolwich, which he always visited with pleasure. It was by his advice, indeed, that a Professorship of Chemistry was added to the establishment of the College; and it was also by his recommendation that the celebrated Dr Adair Crawford was nominated the first Professor in this new chair.

The life of a medical practitioner, absorbed in the laborious duties of his profession, is seldom diversified with much incident; and Dr Brocklesby was now arrived at that period when the approaching infirmities of age demand some relaxation from labour, and an exchange of the anxieties and fatigue of practice, for the tranquil amusements of literature, and the solace of cheerful society. The frugal use which he had made of means originally slender, but progressively augmenting by the increase of his professional emoluments, by the addition of a pension from the Duke of Richmond, his half pay from the army, and an estate which devolved to him on the death of his father, had placed him in circumstances not only independent, but affluent, and enabled him to derive from retirement all the advantages he had contemplated. His society was courted on all sides; and the circle of his friends comprehends some of the most distinguished literary men of the age. He was, during the whole of his life, intimate with Burke. His acquaintance with this extraordinary man, began at the school where they both were educated, and soon ripened into the most warm and most durable friendship. He was also in terms of close intimacy with Dr Johnson, and attended him in his last illness with the assiduity and kindness of a friend. Dr Brocklesby is characterized in Boswell's *Life of Dr Johnson*, as a man whose reading, knowledge of life, and good spirits, supplied him with a never-failing source of conversation; and several letters, addressed to him from Dr Johnson, are preserved in that entertaining work. One trait, however, is omitted, which does him great honour. Understanding that Dr Johnson wished, in the latter part of his life, to remove to the continent for the recovery of his health, Dr Brocklesby immediately made him an offer of an annuity of L. 100 during the remainder of his life; and when this offer was declined, pressed him to reside in his house, as more suited to his health than the one in which he then lived. The same generous disposition was manifested in his conduct to Burke, to whom he transmitted L. 1000, as a legacy he had intended leaving him, but which he thought would be of more use to him at the present time. Dr Brocklesby was, indeed, the survivor of Burke, though only for a few months; for on his return from a visit which he paid to his widow at Beaconsfield, after dining with her two

Brockerby
|
Broker.

nephews Dr Thomas Young and Mr Beeby, of whose education he had taken the principal charge, he expired suddenly a few minutes after retiring to bed, without the least pain or previous illness. He left his fortune, which was considerable, between his two nephews, with the exception of a few legacies to friends and distant relations. (w.)

BROKER, an agent or intermediate person appointed for the transactions of special business for another, somewhat different from an ordinary factor in functions and responsibility. Of this class, there are various descriptions, exercising employments without the smallest analogy, though all are brought under the general name of brokers; and of these, the principal are, Exchange-Brokers, whose province is to ascertain the rates and relation of exchange between countries; Stock-Brokers, who negotiate transactions in the public funds; Insurance-Brokers, who effect insurances on lives or property; and Pawn-Brokers. It is to the last that our attention shall here be chiefly directed.

Pawn-
broker.

Pawn-Brokers are a kind of bankers who advance money at a peculiar rate of interest, on goods impledged for security of the capital; and in case of failure to redeem the goods within a limited time, they may be sold to indemnify the lender.

Nature of
the Trade.

A part of the population of every flourishing country consists of necessitous people, those frequently belonging to a class whose skill contributes to its prosperity; but whose income, often slender and precarious, cannot keep pace with the times, or support the demands of an increasing family. Exposed also to sudden disappointments and losses, they are forced, from the want of pecuniary capital, to seek a temporary relief, by impledging their property for a certain sum, while they pay interest on the advance. But this advance, in general, bears a very inconsiderable proportion to the value of the property, whence its confiscation, by the increasing difficulties of the owner, or of not being claimed on account of death or removal, proves most advantageous to the holder; for, in the one case, he may become the absolute proprietor himself, and, in the other, he secures a high rate of interest originally stipulated. Thus, a pawnbroker has an infinite superiority over an ordinary banker; the latter calculates only on the credit of his debtor, which is frequently nominal; the former never makes an advance without being put in possession of what exceeds it in value; his rate of interest is much greater, and the credit of his debtor is of no importance. Nay it is rather better that his circumstances should be desperate. It thence results, that, like other trades, the number of pawnbrokers will increase with the necessities of the people requiring their aid, and, on that account, giving them employment, just as bankers, whose issues increase when the calls of the public require a more ample supply of a circulating medium. Thus a strong inducement is continually held out to commence the profession of a pawnbroker; for all that is required, is comprised in a licence of L. 10 yearly to Government, a small capital, and an empty warehouse. On such an establishment, business may be done to a great extent in a very short time; because the securities increase in a much greater ratio than

the debts, while the latter are void of any risk. We find in the city of London, that the number of pawnbrokers lately amounted to no less than about 240, and it was calculated, that the property of necessitous persons in their possession, probably amounted to a million Sterling. Their numbers also had suddenly augmented, and they are still augmenting. In Edinburgh, on the contrary, which is not above a tenth part of the size of the metropolis, there was scarcely one a few years ago, and now the number does not exceed a dozen. Therefore the number is not one half in proportion to the population of the two different places, which indicates fewer necessitous people by a half in Edinburgh; arguing, either that the inhabitants are more industrious and more easily maintained, or less exposed to losses and fluctuations.

But the temptations held out to those who, in this manner, obtain possession of the property of others to such an amount, and with so little reference to its value, combined with the natural propensity of mankind to take advantage of the necessities of their neighbours, long ago rendered legislative interference necessary in regulating the duties and interests of pawnbrokers. Besides, it was of great consequence to check the facilities with which stolen goods might be impledged with, and sold by them. Omitting, however, the older enactments on these branches, we shall limit ourselves to those of more recent date.

By the 99th chapter, of 39th and 40th George III., it is provided, that for every pledge on which a sum, not exceeding two shillings and sixpence, shall have been advanced, it shall be lawful to take one halfpenny per month, as interest and indemnification for warehouse room; one penny for five shillings; three halfpence for seven shillings and sixpence; twopence for ten shillings; and if the loan does not exceed forty shillings, the pawnbroker may take at the rate of fourpence for every kalendar month, including that which is current. For any sum exceeding forty shillings and not above ten pounds, he may take at the rate of threepence monthly per pound Sterling. But these sums, though apparently inconsiderable, are in fact high per centages, and far surpassing the legal rate of interest.

The pawner may redeem his goods within seven days after the expiry of the first month, without paying any thing as interest to the pawnbroker on these seven days; and also, if the goods are redeemed before expiry of the first fourteen days of the second month, the profits or interest of one month and a half only are due. But if he fail to redeem them until after the lapse of these fourteen days of the second month, the pawnbroker may demand the profits of the whole second month; and the like regulation is in force for every kalendar month subsequent.

Should the sum advanced on the goods in pawn exceed five shillings, it is enacted that a description of the pledge shall be entered in a book by the pawnbroker, and a note or ticket, an extract copy or duplicate of the same, be delivered gratis to the impledger. If the sum advanced be above five and under ten shillings, the pawnbroker is entitled to a halfpenny for this duplicate; if above ten and under twenty, to one

Broker. penny; and for a copy of the entry of goods pawned for five pounds or more, fourpence may be taken, but nothing higher. Further, an account of the amount of profits shall be written on this duplicate when the goods are redeemed; and pawnbrokers are bound always to produce their books when required. They must likewise exhibit a table of their profits in conspicuous characters in the place where they carry on their business, and register their name and profession over their doors, under a penalty of ten pounds.

Time when pawned goods may be sold.

By the seventeenth section of the statute, it is declared that all goods and chattels which are pawned or impledged, shall be deemed to be forfeited, and may be sold at the expiration of a year, from the date of pawning. But the impledger is, to a certain degree, protected by another clause, prohibiting pawnbrokers from purchasing goods in their own custody. If any sum above ten shillings, and not exceeding ten pounds, has been lent, the goods shall be sold by public auction after expiration of the year, under strict regulations in respect to previous advertisement, and publication of catalogues, specifying, in addition to their description, the month in which they were impledged, as also the name and place of abode of the pawnbroker. But it is provided that pictures, prints, books, bronzes, statues, busts, carvings in ivory and marble, cameos, intaglios, musical, mathematical and philosophical instruments, and china, shall be sold only at four times in the year; namely, the first Monday of January, April, July, and October, and on the following day if the number of articles render it necessary. Thus the impledger may redeem his goods at any time within a year, on payment of the statutory profits on the money lent, but, on his failure, they may be sold. Should he give notice to the pawnbroker before the year closes, of his intention to redeem, the sale must be postponed until three months subsequent to its termination. When the sale has actually taken place, the pawnbroker is entitled to appropriate only so much of the price received as shall cover his own advances, the statutory profits and costs, and must pay the residue to the owner on demand, within three years, under high penalties in event of refusal.

enactments prevent abuses and raids.

Pawnbrokers are prohibited from lending money to persons below twelve years of age, or to those who are intoxicated; nor may they receive any goods in pawn before eight in the morning, or after nine at night, between Michaelmas and Lady-Day; nor before seven in the morning and after ten at night, during the remainder of the year; but with some exceptions which the statutes explain.

A great many enactments are comprised in the statute 39th and 40th Geo. III., respecting the penalties of unlawfully pawning goods the property of another, and those of forging any notes or memorandums regarding them; likewise as to the apprehension and punishment of persons offering goods to pawn who cannot give a good account of themselves. The facility with which loans might be obtained from pawnbrokers on stolen goods, had previously rendered it an object of anxiety with the Legislature to detect offenders. Hence an act was passed

in the 39th of Geo. II. cap. 30, after many preceding ones, annexing the pain of transportation, for fourteen years, to the reset of stolen goods: and by a statute of the preceding year, it was made lawful for a pawnbroker, or other dealer, his servants or agents, to whom any goods should be offered to be pawned, exchanged, or sold, which he suspected to be stolen, to seize and detain the person offering the same, for the purpose of being examined by a justice, who was empowered, if he saw any reason to suppose that the goods had been unlawfully obtained, to commit the persons offering the same to prison, for a period not exceeding six days. Nevertheless all prohibitions are found ineffectual in practice; and although pawnbrokers, in the metropolis, are entitled to carry on their trade only on taking out an annual licence of L. 10, and of L. 5 if in any other part of the kingdom, nothing is liable to greater abuses. It is not uncommon for sharpers and swindlers to obtain such licences, and, taking advantage of the necessitous or unwary, to exercise all possible deceptions on them. Such persons are invariably the receivers of stolen goods, on which advances are made without scruple, from well-knowing that no one will ever return to reclaim them; and, besides, the goods may safely be sold, for the same reason, before the statutory period expires. Without any regard to reputation or integrity, it has proved so easy to be established a pawnbroker, that, it is alleged, persons confined to the hulks on the Thames have even been able to obtain licences to carry on a trade in the very place of their punishment.

However lucrative the business of pawnbrokers may be to those who follow it, doubts are entertained whether the toleration of them be not an evil to the public. They are, indeed, temporarily useful, to persons in the most necessitous circumstances; but as it is impossible, by any Legislative interference, to bring them under that control which would be desirable,—as their interests are always at variance with the interests of their employers,—and as mankind, under the pressure of necessity, are restrained by no sacrifice in seeking momentary relief, ultimate considerations are too often overlooked. Hence the first resort for aid frequently leads to a second, and then to others successively, while the property originally impledged remains unredeemed, and all the rest belonging to the owner gradually diminishes, until he is left destitute. It is the poor and necessitous only who avail themselves of raising supplies on their goods, to ward off some impending evil, and it is surprising how low such transactions are carried. Nay, the statute itself illustrates the nature of this miserable traffic more forcibly than could be done in other terms. It is enacted, that if, at the period of redeeming the goods impledged, there shall be a certain sum due of interest and profit, of which the lowest denomination shall be a farthing, and the redeemer “shall not be able to produce and pay to the Pawnbroker a current farthing, which shall be to the satisfaction and liking of such person or persons as are to receive the same, but shall, in lieu thereof, tender to such person or persons to receive the same, one halfpenny, in order to discharge the said remaining farthing so due, as aforesaid, the said

Broker.

Evils inseparable from Pawning.

Broker
Bronzing.

Pawnbroker or Pawnbrokers, his, her, or their servant or agent, to whom such tender of a halfpenny shall be made, shall, in exchange thereof, deliver unto such person or persons so redeeming goods as aforesaid, one good and lawful farthing of the current coin of this kingdom, or, in default thereof, shall wholly abate the said remaining farthing from the total sum to be received" from the redeemer. But it is not only in the view of the indigent yielding to the pressure of necessity, in parting with their property for an inconsiderable value, that society suffers an injury. The thoughtless and depraved here find ready means of gratifying their propensities, by the assistance of the pawnbroker's shop, and thousands part with their apparel and furniture for what is, the next moment, wasted in intoxication. Besides, the facility of obtaining the reception of stolen goods, is attended with the most pernicious consequences, and the most powerful encouragement to theft. Notwithstanding the law anxiously endeavours to secure property to its owners, by imposing penalties on those who offer it in pawn, and in ordaining it to be restored by the pawnbroker, cases innumerable may be figured, where the pawnbroker cannot discriminate what is the genuine property of any individual in particular, and where it is not only difficult, but may prove impossible, to bring an offender to justice. In the present year (1817), an association, more immediately resulting from the pressure of the times, has been formed in Edinburgh, for the purpose of aiding those with advice and information who have dealings with pawnbrokers. Its special object, we believe, is, to warn the ignorant of the laws under which their property is protected.

The banks called *Savings' Banks* may probably prove a beneficial substitute for resort to the pawnbroker. Sums amounting to a shilling and upwards are received, and bear interest at 4 per cent. when accumulated to twelve shillings; thus enabling the labourer, or mechanic, or artisan, to preserve the remnant of his weekly wages, and convert it to advantage. Loans, not exceeding L. 5, are made, free of interest, to the necessitous under temporary pressure, whereby their little property may remain entire. Banks of this description are, at the present moment, rapidly disseminating throughout the different parishes and towns of Scotland, and their outset has been attended with one decided benefit, in diminishing the resort to alehouses, where the earnings of labour, too small to form an object for preservation, quickly disappeared. In some towns of Italy we have understood there are charitable institutions of a mixed nature between pawnbroking and banking. There, an advance seems to be made on goods pledged at a certain rate of interest by some, and by others money is received and returned, with 7 per cent., at the termination of a year. The transactions of these institutions, however, are not completely explained, either as to the security given or the advantage derived.

(s.)
BRONZING. A combination of metals which has received the name of bronze was employed by the ancients in the fabrication of different utensils, and in casting busts, statues, and other subjects, either larger or smaller than life. The Egyptians,

Greeks, and Romans, nations which subsisted long ^{Bronzing} and were familiar with the most refined state of the arts, used this compound metal in the greater part of the decorations of those magnificent temples and palaces, whose ruins only have remained to later eras. But amidst the general wreck there are still some fragments preserved, which indicate the perfection which was attained in the employment of bronze. The wealth of some ancient cities was estimated by the number of their brazen statues; and Delphos, Athens, and Rhodes, are reported to have each possessed three thousand. Some distinguished Romans adorned the public edifices of their city in this manner; and so strong a propensity was excited for multiplying such works, that an observation became current, that, "in Rome, the people of brass were not less numerous than the Roman people." It has been remarked, that the works which we now execute in iron or steel were little known to the ancients; that their arms and armour were usually of brass, or the compound now alluded to; and a set of surgeons' instruments consisting entirely of bronze was found not long ago at Pompeii.

Bronze is extremely hard, sonorous, more brittle than brass, and more fusible than copper, from which, and its not being liable to tarnish, it is peculiarly adapted for casts of statues. Various nations have compounded the metals employed in different proportions. The Egyptians are said to have taken two-thirds brass and one-third copper. According to Pliny, the bronze of the Grecians was formed in the same way, with the addition of one-tenth part of lead and a twentieth of silver; which proportions were adopted by the Romans. In modern times, bronze is generally composed of two-thirds of copper and one-third of brass, and sometimes small quantities of lead and zinc have been added. These latter render the cast more compact and brilliant; and the combination of different substances occasions the readier fusibility of the whole than when separate. The ancient bronzes, however, present a difference in appearance and composition from those executed by the moderns, and the fact is ascertained in respect to the metallic proportions by skilful chemists on analysis. An illustration of this fact is sometimes given in the four celebrated horses of bronze, supposed to be the work of Lysippus, a Greek artist; which were brought from Venice, by command of Bonaparte, to the Thuilleries at Paris.

The casting of bronze statues is a nice and difficult art, requiring long experience and the judicious management of a great apparatus. An exact model must be made of the subject to be cast, and nicely coated over with wax not less than an inch thick, on which the artist works the impression meant to be taken. A mould is then formed, consisting of several hollow pieces of wood or other resisting substance, filled with a mixture of clay and sand, which is applied to the model, in order that its outline may be received. The mould being united together, is perforated by a number of channels, and the melted metal being discharged from a furnace by means of these into the interior, thus produces the cast. When cold, the external covering is taken off, and the subjects appear as if covered with spines, which are the

bronzing. channels filled with metal; they are removed by saws, files, and chisels, and any imperfections on the surface being corrected, the whole is completed. But this in detail is a tedious, laborious, and expensive process; and the difficulty of producing beautiful works in bronze, conspires to give them a high value in the estimation of the lovers of the arts. In general, the natural colour of the composition remains unaltered, and with the lapse of time, tends to black, or particular shades of green; but some artists render it black artificially, or give it a green colour from the first. It is the delicacy of the workmanship, however, that constitutes the value of bronzes, not the colour, because it is the former alone which constitutes the difficulty, and calls for the skill of the artist. Colossal figures are sometimes obtained in bronze; but more usually, when of very large dimensions, they are formed by the union of several pieces, and are hollow within; as is also the case with some of those of smaller size. Considerable premiums have been offered by the *Society for the Encouragement of Arts*, for promoting the execution of bronze figures in England, but few have been claimed. Nevertheless, British artists have produced several very creditable works, if we take the low condition of sculpture in view; but either from want of skill or practice, neither the bronzes of this Island nor of the Continent rival the masterpieces of antiquity. Perhaps it is only the best specimens which are preserved, and many of inferior note have been allowed to decay, or cease to attract attention; and in this way we may partly account for our own inferiority.

t of
bronzing. The substances on which bronzing is employed are either metals, wood, ivory, clay, or plaster; but more general preference is given to wood or plaster. The colours are of various shades and intensity; their composition and application being in a great measure arbitrary, according to the will of the artist. This art is nothing but a species of painting, far from the most delicate kind; and, when applied to plaster figures, may be done either with or without cement, the latter rendering it more durable. One principal ingredient in bronzing is gold-powder, for the preparation of which the following receipt is given. A quantity of leaf-gold is ground with virgin honey on a stone, until the texture of the leaves be completely broken, and their parts divided to the most minute degree. The mixture of gold and honey is then removed from the stone, and put into a basin of water, whereby the honey may be melted, and the gold freed from it; and the basin is allowed to stand at rest until the gold subsides. When it does so, the water is poured off, and fresh quantities are added, until the honey be entirely washed away; after which, the gold is put in paper, and dried for use. This is the true gold-powder; besides which, there is another, called German gold, in common use; and also a third, called *aurum mosaicum* or *musicum*, greatly employed in bronzing, and is thus prepared. A pound of tin, seven ounces of flour of sulphur, half a pound of purified quicksilver, and the same quantity of sal ammoniac, are taken as the necessary ingredients. The tin being melted in a crucible, the quicksilver is added to it; and, when this

Bronzing. mixture is cold, it is reduced to powder, and ground with the sal ammoniac and sulphur until the whole be thoroughly mixed. They are then to be calcined in a matrass, and the sublimation of the other ingredients leaves the tin converted into the *aurum mosaicum*, which is found at the bottom of the glass like a mass of bright flaky gold-powder. Should any black or discoloured particles appear, they must be removed. The sal ammoniac used here must be very white and clean, and the mercury quite pure, and unadulterated with lead. These colours are commonly employed in bronzing; but when a shade more of a red, resembling copper, is required, it can easily be obtained by grinding a very small quantity of red lead along with them. Copper powder may be procured by dissolving filings or slips of that metal with nitrous acid in a receiver. When the acid is saturated, the slips are to be removed; or, if filings be employed, the solution is to be poured off from what remains undissolved. Small iron bars are then put in, which will precipitate the copper from the saturated acid, in a powder of the peculiar appearance and colour of copper; and the liquid being poured from the powder, this is to be washed clean off the crystals by repeated levigations. In addition to these compounds, we may name gold size, which is of particular use in bronzing, and several other branches of the arts. This is prepared from a pound of linseed-oil, with four ounces of gum animi. The latter is gradually supplied in powder to the oil, while boiling, and it is necessary that it should be stirred with every successive dose, until the whole be dissolved and incorporated with the oil. The mixture is still allowed to continue boiling, until a small quantity, when taken out, appears of a thicker consistence than tar, and the whole being then strained through a coarse cloth, is put aside. When used, it must be ground with as much vermilion as will render it opaque, and, at the same time, diluted with such a quantity of oil of turpentine as will bring it to a proper consistence for working freely with the pencil.

In regard to the operation of bronzing itself, if a cement is to be used, the powders now described may be mixed with strong gum water or isinglass, and laid on the subject with a brush or pencil; in doing which, some artists recommend beginning at the bottom, and proceeding upwards. By a different process, gold size, prepared with a due proportion of turpentine, may be taken, and the subject covered with it; then being allowed to dry very nearly, but still preserving a certain clamminess, a piece of soft leather wrapped round the finger is dipped in the powder, and rubbed over the work; or, what is judged preferable, it may be spread with a soft camel-hair pencil. The whole, now covered, must be left to dry, and the loose powder then cleared away by a hair pencil also. Here the principal nicety consists in ascertaining the proper period of dryness for applying the powder, as much of the effect depends on it. But this method of bronzing is esteemed better, because the gold size binds the powders to the ground, without any hazard of their scaling or rubbing off, which sometimes happens

Bronzing
||
Brosses.

when gura or isinglass are employed. The precise tint of bronzing is regulated by taste; and, indeed, a very perceptible difference appears both in ancient and modern statues, resulting either from age or the metallic proportions.

Bronzing on wood may be effected by a particular process, somewhat varying from the general rules. Prussian blue, patent yellow, raw umber, lamp-black, and pipe-clay, are ground separately, with water, on a stone, and as much of them as will make a good colour put into a small vessel three-fourths full of size, not quite so strong as what is called Clean Size in gilding. This mixture is found to succeed best on using about half as much more pipe-clay as of the rest; but this depends on taste and fancy in preferring a peculiar tint. The wood being previously cleaned and smoothed, and coated with a mixture of clean size and lamp-black, receives a new coating with the preceding ingredients, twice successively, having allowed the first to dry; afterwards the bronze-powder is to be laid on with a pencil, and the whole burnished or cleaned anew, observing to repair the parts which may be injured by this operation. Next, the work must be coated over with a thin lather of Castile soap, which will take off the glare of the burnishing, and afterwards carefully rubbed with a woollen cloth. The gangrenous appearance of the cavities is effected by slightly wetting them with a camel-hair pencil dipped in the lather, and then sprinkling them with a little dust of verditer gum. The superfluous powder may be rubbed off when dry.

In bronzing iron, the subject should be heated to a greater degree than the hand can bear, and German gold, mixed with a small quantity of spirit of wine varnish, spread over it with a pencil. Should the iron be already polished, it is necessary to heat it well and moisten it with a linen rag wet in vinegar, on purpose to obscure the glare, that the bronze-powder may be sufficiently incorporated with the surface. There are other methods of accomplishing the same object, as by employing some coloured mordant, when the iron is not to be exposed to heat, and spreading the bronze over the mordant, when half dry, with a pencil.

Bronze is injured by humidity; and it is said not to preserve its proper quality beyond ten years; but it may be renewed, in which case the subject must be completely cleaned.

There is an analogous method of silvering casts of plaster of Paris, and other substances, which is also called Bronzing, and conducted after the manner above described, but it is not in general repute.

Conjectures have been entertained, that artists originally resorted to bronzing solely for the purpose of correcting the glare of colours; but this is exceedingly improbable, and it is certainly unnecessary to seek farther than the inducement of easily imitating metallic figures esteemed by the curious. This art has, of late years, come into very general use, and has received many improvements. (s.)

BROSSES (CHARLES DE), first President of the Parliament of Burgundy, was born at Dijon, on the 17th of February 1709. He studied law, with

a view to the magistracy, but without neglecting literature and the sciences, to which he discovered an early and decided attachment. His study of the Roman history excited in him a strong desire to visit Italy, which he accordingly traversed in 1739, in company with his friend M. De Sainte-Palaye. On his return to France, he published his *Lettres sur l'état Actuel de la Ville Souveraine d'Herculaneum*, Dijon, 1750, 8vo.—the first work which had appeared upon that interesting subject. A Collection of Letters, written during his Italian tour, entitled *Lettres Historique et Critique*, in 8 vols. 8vo, was published at Paris after his death without the consent of his family. In 1760 he published a dissertation *Sur le Culte des Dieux Fétiches*, 12mo, which was afterwards inserted in the *Encyclopédie Méthodique*. At the solicitation of his friend Buffon, De Brosses undertook his *Histoire des Navigations aux Terres Australes*; which was published in 1756, 2 vols. 4to, with maps, by Robert de Vaugondy. It was in this work that De Brosses first laid down the geographical divisions of Australasia and Polynesia, which were afterwards adopted by Pinkerton, and succeeding geographers. In 1765 appeared his *Traité de la formation Mécanique des Langues*; a work distinguished by much research, and containing many ingenious hypotheses; but, at the same time, marked by that love of theory which is so apt to imbue the cultivators of etymological science.

De Brosses had been occupied, during a great part of his life, in making a translation of Sallust, and in attempting to supply the chasms in that celebrated historian. At length, in 1777, he published *l'Histoire du 7e Siècle de la République Romaine*, 3 vols 4to,—a work which would probably have met with great success, had the style corresponded with the interest of the subject, and with the author's historical sagacity, and depth of research. To the history is prefixed a learned life of Sallust, which was reprinted at the commencement of the translation of that historian by De Lamalle. After the death of De Brosses, a Supplement was added to this work, from his MSS. containing the various readings, fragments, and an Index of the authors from whom they are taken. This Supplement, which should be placed at the end of the third volume, is wanting in some copies.

These literary occupations did not prevent De Brosses from discharging with ability his official duties, nor from carrying on a constant and extensive correspondence with the most distinguished literary characters of his time. During the leisure afforded him by the suspension of the Parliaments, in the year 1771, he applied himself with greater vigour to literature. In 1758, he succeeded the Marquis de Caumont in the *Académie de Belles Lettres*; but was never admitted a member of the French Academy, in consequence, it is said, of the opposition of Voltaire, who entertained a dislike to him.

De Brosses died on the 7th of May 1777. He was a man no less distinguished for ease and vivacity in the general intercourse of society, than for the extent and variety of his literary attainments. Besides the works we have already mentioned, he wrote

Broussonet several memoirs and dissertations in the collections of the Academy of Inscriptions, and in those of the Academy of Dijon. He also contributed a number of articles to the *Dictionnaire Encyclopedique*, on the subjects of Grammar, Etymology, Music, &c. and he left behind him several MSS. which were unfortunately lost during the Revolution. See the *Biographie Universelle*. (H.)

BROUSSONET (PIERRE MARIE AUGUSTE), a distinguished French Naturalist, born at Montpellier, February 28, 1761. His father was a respectable schoolmaster in that town, who, perceiving the avidity with which he received instruction of every kind, took pains to store his mind with knowledge at an early age. It appears from his writings that he was at first educated for the medical profession. The opinion entertained in the university of the success with which he pursued his studies, was proved by his being appointed to fill a Professor's chair when he was only eighteen years of age. So great, indeed, was the reputation he had acquired, that when he offered himself as candidate, a few years after, for a seat in the Academy of Sciences, he was elected a member by an unanimous vote; a circumstance which had hitherto been without example since the foundation of that learned body. Botany seems to have been the science to which he was at first chiefly devoted; and he laboured with much zeal to establish the system of Linnæus in France. In pursuit of this great object, and with a view of extending his knowledge of the science, he visited Paris, and studied every museum and collection from which he could derive instruction in the different branches of natural history. He next came to England, where he was admitted, in 1782, an Honorary Member of the Royal Society. It was also at this period that he published his work on *Fishes*, describing the most rare species of this class of animals, under the title of *Ichthyologia, sistens Piscium Descriptiones et Icones*. London. On his return to Paris, he was appointed perpetual Secretary to the Society of Agriculture, an office which the Intendant Berthier de Sauvigny purposely resigned, that it might be filled by Broussonet.

A life thus dedicated to the pursuits of science, was not likely to be chequered by any remarkable vicissitude. But the Revolution, which soon broke out in France, and for a long time unhinged all the ordinary relations of society, had already involved in its vortex, not only the ambitious and the turbulent spirits of the nation, but also the peaceful votaries of science. In 1789, he was nominated a Member of the Electoral College of Paris, an office which required him to serve as Magistrate, whenever his colleagues were in need of assistance in the exercise of their functions. On the first day when he was called upon this duty, as he was proceeding to the Hotel de Ville, he had the misfortune to see his friend and protector, Berthier, barbarously murdered by the populace. His own life was frequently exposed to great danger during the tumults that ensued, and when he had the charge of superintending the supply of provisions for the capital. In 1791, he had a seat in the Legislative Assembly; but, disgusted with politics, he quitted Paris the year fol-

VOL. II. PART II.

lowing, and repaired to his native city. Persecution followed him in his retreat, and he was glad to effect his escape to Madrid, after encountering many dangers. But though well received and liberally assisted by the Literati of that city, the malignity of the French emigrants, who could not pardon his having held any office under the Revolutionary Government, still pursued him, and drove him from Spain, and afterwards from Lisbon, where he had sought another asylum. He at last went out as physician to an embassy which the United States sent to the Emperor of Morocco. He was furnished with the means of equipping himself by the generous assistance of Sir Joseph Banks, who, informed of his distresses, nobly sent him a credit for L. 1000. After residing for some time at Morocco, during which he lost no opportunity of pursuing his favourite science, he obtained from the French Directory permission to return to France; and he was appointed by them Consul at the Canaries, in which capacity he resided for two years at Teneriffe. On his return, in 1796, he was chosen Member of the Institute, and was reinstated in his botanical Professorship at Montpellier, with the direction of the botanical garden. He was afterwards elected a Member of the Legislative Body, and died of apoplexy, July 27, 1807. France is indebted to him for the introduction of the Merino sheep and Angola goats.

Besides the work on fishes, already noticed, the following are his principal productions: 1. *Variæ positiones circa respirationem*, Montpellier, 1788. 2. *Essai sur l'Histoire naturelle de quelques especes de Moines, décrite à la manière de Linnée*, 8vo. 1784, which is a translation of a Latin Satire on the monks, the original of which appeared in Germany in 1788. 3. *Année rurale, ou Calendrier à l'usage des Cultivateurs*, in 2 vols. 12mo. Paris, 1787-8. 4. *Notes pour servir à l'histoire de l'Ecole de Médecine de Montpellier pendant l'an VI.* 8vo. Montpellier, 1795. He was also a conductor, conjointly with Parmentier, Dubois, and Lefebure, of *La feuille du Cultivateur*, in 8 vols. 4to, published in 1788, and the following years. (W.)

BRUCKER (JAMES), Theologian, Historian, Philologer, and Biographer, was born at Augsburg on the 22d of January 1696. His father, who was a respectable burgher, destined him for the church, and his own inclinations according with his father's wishes, he was sent, at the usual age, to pursue his studies in the University of Jena. Here he took the degree of Master of Arts in 1718; and in the following year he published his *Tentamen Introductionis in Historiam doctrinæ de Ideis*, in 4to; a work which, having afterwards amplified and completed, he republished under the title of *Historia Philosophica doctrinæ de Ideis*, at Augsburg in 1728. He returned to his native city in 1720; but here his merit having attracted envy rather than recompence, he was induced to accept of the office of Parish Minister of Kaufbevern in 1724. In the same year he published a memoir, *De Vita et Scriptis Cl. Etingeri*, Augs. 8vo. His reputation having been at length established by these learned works, in 1731 he was elected a Member of the Academy of Sciences of Berlin, and soon thereafter he was in-

3 X

Brucker. wited to Augsburg to fill the honourable situation of Pastor, and senior Minister of the church of St Ulric. He published, in the same year, three dissertations relating to the history of philosophy, under the title of *Otium Vindelicum, sive Meletematum Historico-philosophicorum triga*, Augsburg, 1731, 8vo. Besides several smaller dissertations on *Biography* and *Literary History*, printed at different times, and which he afterwards collected in his *Miscellanea*, he published at Ulm, in 1737, *Neue Zusatze verschiedner Vermehrungen, &c. zu den kurtzen Fragen aus der Philosophischen historie*, 7 vols. 12mo. This work, being a history of philosophy in question and answer, contains many details, especially in the department of literary history, which he has chosen to omit in his greater work on the same subject. He was forced, by the booksellers, in opposition to his own opinion, to adopt the erotematic method, which at that time had been rendered popular by the writings of Hubner and Rambach.

In 1741, at Leipsic, appeared the first volume of his great work, *Historia Critica Philosophiæ, a mundi incunabilis ad nostram usque ætatem deducta*. Four other ponderous quartos, completing the first edition of this elaborate history, followed in 1744. Such was the success of this publication, that the first impression, consisting of four thousand copies, was exhausted in twenty-three years, when a new and more perfected edition, the consummation of the labours of half a century devoted to the history of philosophy, was in 1767 given to the world in six volumes quarto. The sixth volume, consisting entirely of supplement and corrections, is applicable to the first as well as to the second edition. Of the merits of this work, we shall speak in the sequel.

His attention, however, was not wholly occupied by this stupendous undertaking: the following books would of themselves have been sufficient to exhaust the industry of any ordinary author. *Pinacotheca Scriptorum nostra ætate literis illustrium, &c.* Augsburg, 1741-55, folio, in five decads. *Ehren Tempel der Deutschen Gelehr samkeit in welschen die Bildnisse gelehrter Maenner unter den Deutschen aus dem XV. XVI. und XVII. Jahrhundert aufgestellt, und ihre Geschichte, &c. outworfen sind*, Augsburg, 1747-49, 4to, five decads: *Institutiones Historiæ Philosophicæ*, Leipsic, 1747, 8vo, a second edition, *ibid.* 1756; and a third has been published since Brucker's death, with a continuation by Professor Born of Leipsic, in 1790: *Miscellanea Historiæ Philosophicæ Literariæ criticæ olim sparsim edita nunc uno fasce collecta*, Augsburg, 1748, 8vo: *Erste Anfangsgrunde der Philosophischen Geschichte, als ein Auszug seiner grossern Werke. Zweyte Ausgabe*, Ulm, 1751, 8vo. He likewise superintended and corrected an edition of Luther's translation of the *Old and New Testament*, with a Commentary extracted from the writings of the English Theologians, Leipsic, 1758-70, folio, six parts. His death ensued before this work was finished, which has since been accomplished by Teller. He died at Augsburg in 1770; and he may be added to the catalogue of Huetius, to prove that literary labour is not incompatible with sound health and

longevity. See *Saxii Onomasticon—Biographie Universelle*.—Gesner's *Isagoge*. Brucker.

It is only by his writings on the history of Philosophy that Brucker is now known in the literature of Europe. In this study, his great work forms an important æra, and even at the present day it is the most extensive and elaborate upon the subject. It is, however, a work of which the defects are great, and its errors have been important in their consequences, in proportion to the authority it has acquired. We shall, therefore, hazard a few general observations on the defects which chiefly detract from the perfection and utility of the *Critical History of Philosophy*.

If Brucker had carried into this study a penetration equal to his diligence; and had his general comprehension of the scope and nature of the subject been correspondent to the elaborate minuteness of his details: he would have left us a work which might have had some pretensions to be considered as a rational history of human opinion. He lived, however, at a period when these different qualities were only beginning to be conjoined; and when as yet the history of Philosophy had been written merely as a chronicle of the passing theories of individuals and sects. To give to the science of history a regular and connected form, and to arrange the narrative of successive events, and still more of successive opinions, according to the relation they bear to principles of established influence, was an attempt of which few in that age had any conception, and of which Brucker certainly had none. In civil history, it was then believed, that the historian had fulfilled all the duties of his office, if he strung together the events which were known, or believed to have occurred, in good language, and garnished them occasionally by a few general reflections on the absolute motives of human action. A very different notion is now held of the functions of the historian. He who at present attempts to write the history of any country, must reflect before he begin, what were the chief occurrences in that history, and what were the revolutions which the manners and constitution of that particular nation have undergone. He must bear with him, from the commencement to the conclusion of his labours, a constant impression that every occurrence should be more or less considered, not only as it took place, and as it bore an influence on contemporary affairs, but as it may remotely have contributed to the events, and the opinions, and the character of succeeding times. But if this be true in regard to the histories of particular nations, it is evident, that by how much the traces of opinions are more light and evanescent than those of events,—by how much the speculations of philosophers, whose writings have either perished or come down to us mutilated and obscure; are more difficult to be appreciated in their causes, and connections, and consequences, than the actions of warriors and statesmen; by so much the more is it necessary in philosophical than in civil history, to combine reasoning with erudition, and to substitute the researches of the philosopher for the details of the chronicler. History and philosophy are two different things; and he who

cker. would write the history of philosophy must excel in both. Bacon had long ago required this union, and had pointed out the manner in which the historian of literature should endeavour to establish those principles of connection, which constitute the soul and charm of such a history; how by detecting the union of effects and causes, he might be enabled to determine the circumstances favourable or adverse to the sciences; and how, in short, by a species of enchantment, he might evoke the literary genius of each different age. The fulfilment of this plan was, however, far beyond the capacity of Brucker; and was an undertaking of which he had even no conception. Better qualified by nature and education for amassing than arranging materials, he devoted his principal attention to a confused compilation of facts, leaving to others their application, the discovery of their mutual connections, and the formation of the scattered fragments into a whole.

The merit of his great work consists entirely in the ample collection of materials. The reader who would extract any rational view of the progress of opinion, must peruse it with a perpetual commentary of his own thoughts. He will find no assistance from his author, in forming any general views, or in tracing the mutual dependencies of the different parts of the subject. Brucker has discovered the fountains of history; but he has made us drink of them without purifying the draught. Even in this respect, his merit has been greatly overrated. Vast as is the body of materials which he has collected, we are always missing those very things which we might reasonably have expected would have been the first objects of a rational inquirer, and we are continually disappointed of the information we are most anxious to acquire. The idle and slavish attention which he has bestowed on previous compilers, has frequently diverted him from the study of the original authors themselves. Quoting the passages of the ancients from others, or trusting, perhaps, to the reference of an index, he has frequently overlooked those very testimonies which could have given us the most authentic knowledge of the opinions or characters of ages and individuals. He has often presented the authorities he has adduced, mutilated or misapplied; and this either from not having sufficiently studied these passages in their general connection with the system they illustrate, or from having been unable to withdraw them from the obscurity in which they were involved. He has shown no critical sagacity in distinguishing the spurious from the authentic, or in balancing the comparative weight of his authorities. He has frequently transcribed, where he ought to have explained, the words of the original authors; and, without taking into account the different value of the same term in different nations and ages, he has left us to apply a doubtful or erroneous meaning to words which might have been easily rendered by other expressions, and to suppose a distinction in the sense, where there only existed a difference in the language. The glaring errors, even, which occasionally occur in his expositions of the Grecian philosophy, while they are inconsistent with any critical know-

ledge of the tongue, would make us suspect that he was in the habit of relying on the treacherous aid of translations. In short, if we knew nothing more of the ancient philosophers than what we acquire from Brucker, we should be often obliged to attribute to them opinions, so obscure or so absurd, that we must either believe ourselves wrong in the interpretation; or be unable to comprehend the cause of all the admiration and reverence they have received.

He has discovered little skill in his analyses of the different Systems of Philosophy; and the confusion of what is essential and principal with what is accidental and subordinate, clearly evinces, that these abridgments were thrown together while acquiring, in detail, a knowledge expressly for the purpose, instead of being the consummation of a long and familiar meditation on the subjects in all their modifications and dependencies. He has dwelt with the most irksome minuteness on every unimportant and doubtful circumstance in the lives of the Philosophers; but he has too often overlooked the particular and general causes that produced an influence on the destinies of their philosophy. The aphoristic method which he has adopted, prevents him from following a consecutive argument throughout its various windings. The most convincing reasoning, in his hands, loses much of its demonstration and beauty; and every ingenious paradox comes forth from his alembic a mere *caput mortuum*,—a residue from which every finer principle has been expelled. Where the genius of the Philosopher is discovered more in the exposition and defence, than in the original selection and intrinsic stability of his tenets, Brucker has not found the art of doing justice both to the Philosopher and his opinions, or in conveying to the reader any conception of the general value of the original. This last defect, it must, however, be acknowledged, is, more or less, inseparable from every abstract of opinions, where it is always necessary to separate, in some degree, what is essential to the subject from what is peculiar to the man. He has relieved the sterility of his analyses by none of the elegancies of which the subject was susceptible. Without any pretension to purity, his diction is defective even in precision; and his sentences, at all times void of harmony and grace, are abrupt, and often intricate in their structure.

The person, therefore, who would attempt to write a history of Philosophy, without the imperfections of that of Brucker, must draw from obscurity many important facts hitherto omitted; he must arrange and combine these in a more perspicuous order; and, above all, he must review the opinions he shall thus relate and methodise with a more accurate criticism. He ought not to write of Peripatetics like a disciple of Aristotle, of Platonists like a pupil of Proclus, nor of the doctrines of the Porch like a follower of Zeno. Still less must he compare the tenets of one sect by the principles of another; or endeavour to estimate doctrines, dubious in themselves, by reference to a standard equally arbitrary and contingent. He must place himself, to use the language of Lucretius, upon the highest pinnacle of the temple of science, from whence he may look calmly back, and

Brucker. compare and study the doctrines of all these departed sages, without being himself involved in the partialities of particular sects or opinions,—

*Despicere unde quæsit alios, passimque videre,
Errare, atque viam palæstris querere veri.*

He must honour the genius of all alike; and believe that all are deserving of commendation, although all are more or less subject to error. He ought, in short, to be a Philosopher superior even to the prejudices of philosophy.

If we take a survey of what has been attempted since the death of Brucker, in accomplishing a more perfect history of philosophy, we shall find that more has been done in illustrating the philosophical tenets of particular sects, or the progress of particular portions of science, than in giving a comprehensive view of the general history of thought. In France, in Italy, and in our own country, those who have laboured in this work, far from being able to correct the errors of Brucker, have, in general, through defect of erudition, been wholly indebted to his industry for their materials, and been content to rely on his accuracy with more than Pythagorean faith. If we except some ingenious speculations, which are more of the nature of philosophical essays on the history of philosophy, and which endeavour rather to illustrate the general spirit, than to detail the particular opinions of the philosophers, there is nothing valuable on this subject to be found in the literature of these countries. Among the learned of his own country, Brucker has never enjoyed a very distinguished reputation; and the Germans, while they were the most capable of discovering his defects, have had the honour of most sedulously and successfully endeavouring to supply them. We are indebted to them, especially, for many valuable treatises on the history of particular portions of philosophy, in which we find, at length, a profound reasoning united to an extensive and original erudition. The works of Meiners, Fulleborn, Tiedmann, and perhaps Buhle, deserve especially to be distinguished. An undertaking, however, which, from the extent of its plan, as well as the ability of its execution, claims particular notice, is the *History of Philosophy*, by Professor Tenneman of Jena. This work, as far as it is completed, affords us the most accurate, the most minute, and the most rational view we yet possess, of the different systems of philosophy, in their intrinsic and relative bearings. The author has not only given us a minute analysis of each system, the result of a profound and familiar study of the original Philosopher, but he has also displayed to us his philosophy, divested of its peculiarities, and compared with others by a general and impartial review. The main defect of this work, at least in reference to readers not German, is, that, like Buhle and the other disciples of Kant, he has taken the Critical philosophy as the vantage-ground from whence to make his survey of all former systems. Thus the continual reference to the peculiar doctrines of the school of Kant, and the adoption of its language, render it frequently impossible for those who have not studied the dark works of this modern Heraclitus, to under-

stand the strictures of Tenneman on the systems even of Aristotle or Plato. (Kk.)

BRYANT (JACOB), a profound scholar, mythologist, and sacred historian, born at Plymouth in 1715. His father had a place in the Customs, and was afterwards stationed in Kent, where his son was first sent to a provincial school, from which he was removed to Eton. Here he appears to have remained till 1736, the date of his election to King's College, Cambridge, and he took his degrees of Bachelor and Master of Arts in 1740 and 1744. He returned to Eton in the capacity of private tutor to the late Duke of Marlborough, then Marquis of Blandford; and the good taste which his pupil shewed through life, in the protection of the fine arts, and in the pursuit of science, sufficiently demonstrated the beneficial influence of his instructor's example. In 1756, he went to the Continent as Private Secretary to the Duke of Marlborough, then Master-General of the Ordnance, and Commander in Chief of the forces in Germany; and he was rewarded, after his return, for his various services to the family, by a lucrative appointment in the Ordnance, which allowed him ample leisure to indulge his literary taste in a variety of refined investigations, and to exercise his zeal for the cause of religion in a multitude of works, calculated for the illustration of the Scriptures, and the demonstration of their authenticity and divine authority.

1. His first publication was entitled *Observations and Inquiries* relating to various parts of Ancient History, containing Dissertations on the wind Euroclydon, and on the Island Melite, together with an Account of Egypt in its most early state, and of the Shepherd Kings, 1767. In this work he attempts to prove that the Melite, on which St Paul was wrecked, was not Malta, but one of the Illyrian islands in the Adriatic, now called Meledé; and he endeavours to illustrate several points in the early history of the oriental, and especially of the Aramitic nations.

2. But his most elaborate performance was his *New System or Analysis of Ancient Mythology*, wherein an attempt is made to divest tradition of fable, and to reduce truth to its original purity, 3 vols. 4to, 1774, 1776. In this attempt, the author has equally displayed his deep and extensive learning, and his inventive fancy; but it must be confessed that, on a minute examination, the work exhibits much more of a poetical imagination than of a sound judgment, and that, in endeavouring to substitute etymological for historical evidence, he has been completely unsuccessful. Nothing can afford a more satisfactory kind of proof than etymology taken on a large scale, and considered as a mode of tracing the relations of nations to each other, by the affinities of their languages; since the accumulation of a multitude of probabilities, each weak when taken separately, becomes at last equivalent to a certainty. But nothing, on the other hand, can be more fallacious, or more liable to controversy, than single etymological inferences, in particular cases, when one of these slight resemblances is magnified into a striking likeness, and even an identity, which is then made the foundation of a magnificent superstructure in mythology or in history.

Bryant.

Mr Richardson has shown, in the Preface to his *Dictionary*, how much Mr Bryant was mistaken in some of his reasoning respecting the signification and derivation of particular words; and even if he had been more correct in these instances, the conclusions, which he has deduced from his etymologies, would by no means have been perfectly legitimate. Jablonsky seems to have exhibited one of the strongest examples of this dangerous abuse of learning; in which he has been followed not only by Mr Bryant, but by several other modern writers equally visionary, who have commonly been very imperfectly acquainted with the languages on which their conjectures have depended, and have been still more deficient in that sort of common sense, and correct feeling, confirmed by experience, which constitutes the most essential part of the qualifications of a critic, and the want of which can never be compensated by the most unwearied labour of a mere mechanical commentator.

3. Some remarks, which had been made on particular passages of Mr Bryant's work, led him to publish *A Vindication of the Apamean Medal*; of the inscription ΝΩΕ; and of another coin, in the *Archæologia*, Vol. IV. Art. 21, 22, 23. 4. He deviated somewhat more widely from the usual objects of his researches, and apparently without any very decided advantage over his adversary, in *An Address to Dr Priestley*, on the doctrine of philosophical necessity, 8vo, 1780. 5. He also published in the same year *Vindiciæ Flaviansæ*, or a vindication of the testimony given by Josephus concerning our Saviour, 8vo.

6. Unfortunately for the credit of his critical discrimination in matters of old English literature, Mr Bryant was the author of *Observations on the Poems of Thomas Rowley*, in which the authenticity of these poems is ascertained, 2 vols. 12mo, 1781. If there could be any excuse for the commission of forgeries like that of Chatterton, it would be found in their serving as a valuable test of the degree of confidence, which it is justifiable to place, in the decrees of the most powerful critics, respecting other questions of a more ambiguous nature.

7. Mr Bryant contributed to the publication of the *Duke of Marlborough's Collection of Gems*, the Latin explanations contained in the first volume, fol. 1783. 8. He inserted in the *Archæologia*, VII. 387, some *Collections on the Zingara or Gipsy Language*; which has been since sufficiently proved to be one of the many derivatives of the old Sanscrit. 9. Sometime afterwards, he published an anonymous *Treatise on the Authenticity of the Scriptures*, and the truth of the Christian religion, 1792. 10. This was succeeded by his *Observations upon the Plagues inflicted upon the Egyptians*, 8vo, 1794.

11. His opinions respecting the existence of the city of Troy, and the veracity of Homer as a historian, raised up against him a host of powerful adversaries; and in a question of this nature, upon which the decisions of mankind are so manifestly influenced by their sensibility to poetical beauty, and their early habits and attachments, a much more cautious attempt to innovate might easily have been unsuccessful. Whatever learning and talents may have

Bryant

Buat.

been exhibited in this controversy, it will hardly be believed by an impartial judge, reasoning on the general probabilities of the case, that Homer intended the actions of his heroes, any more than their genealogies, to be historically correct; but, at the same time, it will readily be admitted, that he was much more likely to take, for the scene of his poem, a town that had really existed, and, for its subject, a traditional report of a war which had actually been carried on, than to have invented a fabulous city and an imaginary warfare, without any historical foundation whatever. Mr Bryant published on this subject *Observations on a Treatise*, entitled, *Description of the Plain of Troy*, by Mr de Chevalier, 4to, 1795. 12. *A Dissertation concerning the War of Troy*, and the expedition of the Greeks, as described by Homer; showing that no such expedition was ever undertaken, and that no such city in Phrygia existed, 4to, 1796. 13. *Observations on the Vindication of Homer*, written by J. B. S. Morritt, Esq. 4to, 1799.

14. He had, in the meantime, not discontinued his theological studies, and had published an *Essay on The Sentiments of Philo Judæus* concerning the word of God, 8vo, 1797. His last work was a volume of *Dissertations on Various Subjects in the Old Testament*, which had been nearly completed thirty years before. The subjects which had particularly attracted his attention, were the histories of Balaam, Sampson, and Jonah; and besides Philo Judæus and Josephus, he had endeavoured to illustrate some controverted passages of Justin Martyr, as well as many other departments of religious and historical discussion.

The habits of Mr Bryant's maturer life were in general completely sedentary; although, in his youth, he had taken his full share in the cultivation of the many exercises common to Etonians, and had once the good fortune to save, by his proficiency in swimming, the life of Dr Barnard, afterwards Provost of Eton. His conversation was elegant and animated; his manners mild but firm; he exerted himself to please others, and was himself easily pleased. He was much courted in society, and his residence, at Cypenham, near Windsor, was not unfrequently visited by persons of the highest possible rank. He never married. He died in his 89th year, the 14th November 1804, from the immediate consequence of an accidental blow. He left his library to King's College, having, however, previously made some valuable presents out of it to the King, and to the present Duke of Marlborough. He also bequeathed L. 2000 to the Society for the Propagation of the Gospel, and L. 1000 for the use of the supernumerated collegers of Eton School. [*Gentleman's Magazine*, LXXIV. p. 1080. 1165. *Nichols's Literary Anecdotes*, IV. 667. 8vo, Lond. 1812. *Aikin's Biographical Dictionary*, X. Supplement.] (N. A.)

BUAT-NANCAY (LOUIS GABRIEL, COUNT DU), was born of an old family in Normandy, on the 2d of March 1732. At an early age, he entered into the Order of Malta; and, by a fortunate accident, he became acquainted with the Chevalier Folard, author of the *Commentaries on Polybius*, who received him into his house, and superintended his education.

Buat
Buckinghamshire.

Folard had a nephew, who was Minister for France at different German Courts, and under whom Buat studied History and Diplomacy. He was successively Minister for France at Ratisbon and Dresden; but afterwards, becoming disgusted with this career, he retired from public life, in the year 1776. He died at Nançay, in Berry, on the 18th of September 1787.

Buat was a man of some talents, and considerable literary attainments, but possessing little knowledge of the world; which circumstance seems to have, in a great measure, disqualified him for public employment. He appears to have written with great facility; but his style is very unequal. His works are: 1. *Tableau du Gouvernement actuel de l'Empire d'Allemagne*, translated from the German of Schmauss, with notes historical and critical. Paris, 1755, 12mo. 2. *Les Origines, ou l'Ancien Gouvernement de la France, de l'Italie, et de l'Allemagne*, published at the Hague, 1757, 4 vols. 12mo. 3. *Histoire Ancienne des Peuples de l'Europe*, Paris, 1772, 12 vols. 12mo. This is the largest, and perhaps the best work of Buat. 4. *Les Elémens de la Politique, ou Recherches sur la vrais Principes de l'Economie Sociale*, 1773, 6 vols. 8vo. 5. *Les Maximes du Gouvernement Monarchique, pour servir de suite aux Elémens*, 4 vols. 8vo. There is also ascribed to Buat a work entitled *Remarques d'un Français, ou Examen impartial du livre de M. Necker sur les Finances*, Geneva, 1785, 8vo. In his youth he had composed a tragedy, entitled *Charlemagne, ou le Triumphe des Lois*, published at Vienna, 1764, 8vo. He likewise contributed several articles to the journals of his time, on different points of history, literature, and political economy; in particular, some excellent observations on the character of Xenophon, &c., inserted in the fourth volume of the *Variétés Littéraires*. See *Biographie Universelle*. (H.)

Boundaries.

BUCKINGHAMSHIRE is divided from Berkshire by the river Thames, during a course of about 28 miles, from about a mile to the north of Henley Bridge to the conflux of the farthest stream of the Colne: for a course of about 14 miles, the Colne is the eastern boundary between this county and Middlesex. The Thame, in its course from the town of that name, is, for a very few miles, the boundary between Buckinghamshire and Oxfordshire. The Ouse first becomes a boundary between this county and Northamptonshire, near Brackley; and for a few miles beyond Westbury, it divides it from Oxfordshire; after it passes Thornton, it again becomes, for a few miles, the boundary between Buckinghamshire and Northamptonshire; and just before it quits the county, it forms the boundary between it and Bedfordshire. The Ousel is the boundary between these two counties, from Eaton Bray to Linchlade. The figure of this county approaches to that of a crescent, but its outline is rendered very irregular by projections and indentations. From the south-eastern to the north-western extremity, it measures nearly 50 miles; but its greatest breadth is scarcely 18: it is about 188 miles in circumference. According to the *Report to the Board of Agriculture*, it contains 518,400 acres; but, according to the returns to Parliament,

Form and Extent.

of the poor's rates, only 478,720; and Dr Beeke, in his *Observations on the Income-Tax*, calculates the number of acres at 461,729. The parishes, according to the Parliamentary returns respecting the poor's rates, amount to 223, and not 185, as stated in the *Encyclopædia*. The fourteen Members for Parliament are returned,—two for the county; two for Buckingham; two for Aylesbury; two for Wycombe; two for Amersham; two for Wendover; and two for Marlow. There are seven deaneries in it. Though in the diocese of Lincoln, four parishes are in the peculiar jurisdiction of the Archbishop of Canterbury, and four others are in the diocese of London, and in the jurisdiction of the Archdeacon of St Albans. The great tithes of ninety-two parishes are in lay hands, and most of the remainder are held by lay leases. The Summer Assizes are held at Buckingham,—the Lent Assizes at Aylesbury. The Quarter-Sessions are always held at Aylesbury. This county contains many magnificent seats; among which the most celebrated are Stowe, the seat of the Marquis of Buckingham,—Bulstrode, formerly belonging to the Rutland family, but lately purchased by the Duke of Somerset,—Dropmore, the seat of Lord Grenville,—Taplœ House, the seat of the Marquis of Thomond,—Wycombe Abbey, of Lord Carrington.

The southern part of Buckinghamshire, beyond the Thames, is principally occupied by the Chiltern Hills. The soil of these is chalk, intermixed with flints. They stretch across the country from Bedfordshire to Oxfordshire, forming a part of that great chain which extends from Norfolk to Dorsetshire. On the west side of the county, adjoining Oxfordshire, is a range of hills of calcareous stone. In that part of the county which borders on Bedfordshire, about Wavendon, Broughton, and the Brick-hills, the soil is a deep sand. The Vale of Aylesbury, of proverbial fertility, which lies under the Chiltern Hills, and occupies the middle of the county, is formed of a rich black loam, on a calcareous subsoil. In the northern parts of the county, the soil is chiefly clay; but, on the Bedfordshire border, the surface rises into gentle sand-hills. The whole of the Chiltern district is said formerly to have been a forest; the western part, occupied by the forest of Bernwood, was disforested in the reign of James I. At present, the chief woodlands lie to the south of the Chiltern Hills. On a tract of land, extending across the parish of Little Kimble into that of Great Kimble, there are about 100 acres of box-wood, apparently the natural growth of the soil. The black cherry abounds in the neighbourhood of Chesham. The prevailing timber in the southern part of the county is beech; one wood of which, in the parish of Wycombe, is said to contain 700 acres; nearly one-sixth part of the land between the road to Oxford and the Thames, is supposed to be covered with this wood. Whaddon Chace is the principal woodland in the northern part of the county, containing 2200 acres of coppices. The rivers of note are the Ouse and the Thames; the Ouse enters Buckinghamshire, on the west side, near Water Stratford, which it passes, and then flows in a devious course

to Buckingham; thence winding to the north, through a rich tract of meadow land, it reaches Stoney Stratford, Newport Pagnell, and Olney; soon afterwards, turning suddenly to the east, it leaves the county near Brayfield. One of the most considerable streams of the Thames, rises near the borders of the county, in Hertfordshire, and flowing through the Vale of Aylesbury, from east to west, receives the waters of several smaller streams, and enters Oxfordshire, near the village of Ickford; its course through Buckinghamshire is about 30 miles. The grand junction canal enters this county near Woolverton, and, running eastward, goes within a mile of Newport Pagnell; thence flowing to the south, it passes Fenny Stratford, Stoke-Hammond, Cinslade, and Ivinghoe, into Hertfordshire. From a branch of the canal at Old Stratford, a cut has been made to Buckingham; and another from Bulbourne to Wendover.

On the borders of Bedfordshire, are the celebrated fuller's-earth pits, one of which only is now occasionally worked. Mr Pennant thus describes the *strata*: "The beds over the marl are, first, several layers of reddish sand to the thickness of six yards; then succeeds a *stratum* of sandstone, of the same colour, beneath which, for seven or eight yards more, the sand is again continued to the fuller's-earth, the upper part of which being impure, or mixed with sand, is flung aside; the rest taken up for use. The earth lies in layers, under which is a bed of rough white freestone, and under that sand, beyond which the labourers have never penetrated." A striated species of *Nautilus* is found in great abundance, and frequently of a very large size, in the yellow limestone near Dinton. The only very rare plant known to the botanists as indigenous to this county, is the *Dentaria bulbifera*, which grows abundantly in its south-east corner. The great snail, or *Pomatia*, Mr Pennant was informed, is found in the woods near Gothurst; and he regards this as its most southern residence in England. We have seen it, however, near Ashted in Surrey; and the tradition there, as in Buckinghamshire, is, that it was introduced from abroad for medicinal purposes.

Formerly, the commons, common fields, and wastes in this county, bore a very large proportion to the whole of its area; but, at present, their whole extent is very inconsiderable, except in the vale of Aylesbury, where the common fields are still numerous. Between the 1st of Queen Anne and the year 1797, there were thirty-one inclosure-acts passed for this county, comprehending 38,457 acres; besides 22 acts, in which the number of acres was not specified; and during the first 40 years of his present Majesty's reign, there were 61 acts of inclosure passed. In other respects, however, the agriculture of this county has not advanced much, principally in consequence of the restrictions in the leases. It has long been remarkable for its produce of corn and cattle. "Buckinghamshire bread and beef," was an old proverb. As far back as the time of Camden, numerous flocks of sheep were fed in the vale of Aylesbury, which yielded great profit from their wool; and Fuller informs us, that, in his

time (1660), the largest sheep in England were bred in this vale, and that it was not unusual to give L. 10 or more for a ram. At present, this vale is principally employed in feeding oxen for the Smithfield market, and in furnishing immense quantities of butter to the London dealers. Eight pounds is the average weight of butter produced weekly from each cow in summer, and six the average in winter. In the northern parts of the county, great numbers of calves are bred, which are purchased at Aylesbury market by the farmers of the Chiltern district, and by them fattened for the markets of the metropolis. The skim and butter-milk of the dairies are employed in fattening vast numbers of swine. There is a very small proportion of arable land in the northern division of the county; and not much in any other part, except the Chiltern districts. Here the crops usually cultivated are wheat, barley, oats, beans, and sainfoin. In the neighbourhood of Aylesbury, they are famous for rearing ducks very early in the spring, and sometimes by Christmas; these are sent to London, and sold at a very high price. The ducks are prevented from laying, by artificial means, till October or November. A few weeks before they lay, they are fed highly; the eggs are hatched by hens, which are frequently exhausted to death, by sitting on three broods successively. As soon as the ducklings break the shell, they are nursed with particular care at the side of a fire.

The only manufactures of consequence in this county are those of bone-lace and paper. The former is principally carried on at Olney, Newport Pagnell, and Hanslope, a village about five miles north-west from Newport Pagnell. In this village, in the year 1801, 800 out of a population of 1275 were employed in this manufacture. The lace made here sells from sixpence to two guineas a yard. But, since lace has been made on the frame at Nottingham, Loughborough, and other places in that neighbourhood, the bone-lace manufacture of Buckinghamshire has been greatly on the decline. The manufacture of paper has been carried on in the neighbourhood of Wycombe for more than a century. On that part of the small river Wyke which passes through this parish, there are fifteen corn and paper-mills. At Amersham, besides the lace manufacture, there is a manufacture of sacking; and one for all kinds of white cotton goods. At Marlow are manufactures of paper and black silk lace, large works of copper, brass, and brass-wire, and mills for making thimbles, and for pressing rape and linseed oil. The principal markets in the county are those of Aylesbury, Buckingham, and Wycombe. Marlow fair is much celebrated for its show of horses.

The church of Stewkley is one of the most complete specimens of Saxon architecture now remaining; no part of it, externally or internally, having been altered or materially defaced; nor have any additions been made to it, except the porch on the south side, and the pinnacles of the tower. The date of 1106 is said to have been observed on a stone by some workmen who were repairing the roof or the Chancel. The Chancel of the church of Chetwode, supposed to have been founded in the year

Buckinghamshire.

Buckinghamshire.

Fuller's-earth.

Natural history.

Agriculture.

Architectural Antiquities.

Buckinghamshire
Buckinghamshire
Buckinghamshire

1244, has lancet-shaped windows, with slender pillars, the capitals of several of which are highly enriched with foliage and figures of animals. Hillesden Church, which was rebuilt about the year 1493, affords a rich specimen of the later Gothic. Some of the most ancient and elegant specimens of stained glass in the kingdom, remain in the chancel of Chetwode Church; as there is little doubt that this glass was coeval with the erection of the church, in 1244, it may be considered as one of the earliest specimens of the kind produced in England. The cross built upon the side of a hill, near the hamlet of Whiteleaf, is supposed to have been erected in the reign of Edward the Elder, to commemorate a battle fought against the Danes; it is about 100 feet high, and 50 broad, tapering to 20.

Poor's Rates.

In the year ending Easter 1803, the total money raised by poor's rates, and other parochial rates, was L. 105,378, 14s. 11½d.; on the average of the three years 1783, 1784, and 1785, it was L. 48,242, 15s. 2d.; and in the year 1776, it amounted to L. 37,052, 18s. 1d. In the account of the poor's rates for the year ending 25th March 1815, ordered by the House of Commons to be printed 26th February 1816, there are no returns from this county.

Population.

In the year 1377, the number of persons in Buckinghamshire, charged to a poll-tax, from which the clergy, children, and paupers were exempted, was 24,672. In the year 1700, the population amounted to 80,500. In the year 1801, by the returns under the act of Parliament, there were 20,443 inhabited houses, and 543 uninhabited. The total number of inhabitants was 107,444, of whom 52,094 were males, and 55,350 females. Of this total number, 25,083 were employed in agriculture, and 20,138 in trade, manufactures, or handicrafts. In the returns of the population act in 1811, the following results are given:

Inhabited houses	-	-	21,929
Families inhabiting them	-	-	25,201
Houses building	-	-	119
Uninhabited houses	-	-	457
Families employed in agriculture	-	-	13,938
Ditto in trade, &c.	-	-	8,424
Ditto not comprehended in preceding classes	-	-	2,844
Males	-	-	56,208
Females	-	-	61,442
Total population			117,650
Ditto in 1801			107,444
Increase			10,206

See *Beauties of England and Wales*, Vol. I.—*General View of the Agriculture of Buckingham* by Priest.—*Lyson's Magna Britannia*, Vol. I.—*Pennant's Tour from Chester to London*. (c.)

BUDUKSHAUN, a mountainous country, or rather range of mountains, in Asia, reaching northwards, from the great ridge of Hindoo Coesh to the source of the Oxus. It forms thus the western boundary of the territory of Kaushkaur. The whole range is covered with snow during the greater part of the year; but there is only one point of per-

petual snow, being that from which the Oxus and Kama take their rise. The territory is watered also by a considerable river, called the Koocha, which falls into the Oxus. The mountains contain many valuable mines of silver, iron, antimony, and lapis lazuli. Budukshaun is celebrated also for mines of rubies, situated on the lower hills, near the Oxus; but they are no longer wrought.

This country, from its inaccessible situation, has generally maintained its independence against any foreign power. The present chief, Sultaun Mahomed, is said to be absolute over his own subjects. He has a revenue of about L. 60,000, and maintains from 7000 to 10,000 men, armed with matchlocks, in the use of which the Budukshes are said to be peculiarly expert. The capital is Tyzabad, a considerable town situated on the river Koocha.

(B.)
BUENOS AYRES, one of the viceroalties into which the Spanish dominions in South America are divided, and the most extensive of the whole. To the south and north its limits are not exactly defined, as it stretches into extensive deserts inhabited only by savages, and little known. Its southern boundary may be considered to extend from Cape Lobos westward to the Rio Colorado; on the north it is bounded by Amazonia, or the country of those independent Indians who wander about the Amazons and its tributary streams; on the east by Brasil and the Atlantic Ocean; and on the west by the great ridge of the Cordilleras, which separates it from Chili, and further to the north from Peru. From Cape Lobos to the furthest northern settlements on the Paraguay, it extends upwards of 1600 miles; and from Cape St Anthony at the mouth of the Plata, to the ridges that separate it from Chili, 1000 miles. It was erected into a viceroyalty in 1778, and several districts were added to it from Peru and Chili. From the latter those provinces were principally taken which are situated on the eastern declivity of the Andes.

The viceroyalty of Buenos Ayres is divided into five governments or provinces, namely,

I. Buenos Ayres, or Rio de La Plata, of which the chief towns are Buenos Ayres the capital, Santa Fe, Monte Vidéo, and Maldonado on the opposite shores of the river.

II. Paraguay, of which the chief town is Assumption.

III. Tucuman, of which the chief towns are San Jago del Estero, and Cordova.

IV. Los Charcos, or Potosi, formerly part of Peru, and comprehending the new district of Santa Cruz de la Sierra. The chief towns are La Plata, Potosi, Santa Cruz de la Sierra, and La Paz.

V. Chiquito, or Cuzco, formerly part of Chili, of which the chief towns are Mendoza, and San Juan de la Frontera.

The viceroyalty of Buenos Ayres forms a compact body of land nearly square, lying between the mountains of Brasil on the east, and the Cordilleras of Peru and Chili on the west. Towards the south, from those great ranges of mountains, a considerable tract of elevated country branches into the interior, in which arise all the numerous streams by which the country

Buckinghamshire
Buckinghamshire
Buckinghamshire

enos
res.

is watered; whilst its western and southern parts, descending by gradual slopes, run into extensive, and in some places marshy, plains to the foot of the Cordillera of Chili.

It is chiefly by means of the Rio de la Plata, that those extensive regions are drained of their waters; all the streams which have their rise in the eastern declivity of the Chilian Andes, or that descend from the western ridges of Brasil, being ultimately carried into the channel of this great river. In the upper part of its course, it is known by the name of the Paraguay, and runs nearly in the centre of the American continent, from N. to S., receiving from the mountains of Brasil the two great streams of the Parana and the Uruguay, while from the west it receives the Pilcomayo, the Vermejo, and the Salado, which flow down the eastern declivity of the Andes.

It was called Rio de la Plata, or *River of Silver*, by Sebastian Cabot, from his having taken a considerable booty, in gold and silver, from a body of Indians whom he defeated on its banks, and this imposing title it has ever since retained. This appellation, however, though no doubt intended by its author to apply to the whole of the river, is now confined to the channel by which the Paraguay, the Panana, and the Uruguay, pour their united waters into the ocean. This vast estuary of fresh water, which is without a parallel for width and magnificence, is 150 miles broad at its mouth, from Cape St Maria, on one side, and Cape St Anthony, on the other. Between Monte Video and the Punta de Piedras, which some have considered its proper limits, it is 80 miles in breadth; and at Buenos Ayres, which is 200 miles from its mouth, its breadth is about 30 miles; and, the shores being low, it is seldom that they can be seen from opposite sides. This immense inland sea is, however, rendered dangerous for the purposes of navigation, not only by rocks and sand-banks, which are the terror of mariners, and which greatly detract from its utility; but by tempests of wind which, bursting forth from the south-west, sweep over the boundless plains of the *Pampas*, where they meet with no obstacle to oppose them, and rush down the wide opening of the Plata with unequalled fury. A thunder storm is the general prelude to those destructive blasts, which are known by the name of the *Pamperos*; so that the mariner, being warned of the coming tempest, generally seeks shelter in some of the neighbouring ports.

The greater part of the country included within the viceroyalty of Buenos Ayres, forms, according to Azara, a vast plain, of which the uniform level is hardly ever interrupted by hills of a greater elevation than of 90 toises above their base; and it has been calculated, by barometrical observations, that the great river Paraguay, in its progress southward, does not fall above one foot in perpendicular height between the 18th and 22d parallels of south latitude. In like manner it is asserted, by persons well acquainted with the country, that when the easterly winds occasion the rivers of Buenos Ayres to rise to the height of seven feet above its

ordinary level, this rise is perceived in the river Panana at the distance of 60 leagues.

In consequence of this flatness of the country, the rains which fall upon the Cordilleras are stopped when they descend into the plain, and are insensibly evaporated; so that a number of small rivulets which, under a different configuration of the ground, would be collected into rivers, are here checked in their course, and gradually evaporated. Nor can any art or skill ever remedy this physical defect of the country; for the same cause which prevents its superfluous moisture from forcing its way to the ocean, would equally prevent the conveyance of water by means of any artificial canal. In Buenos Ayres, accordingly, and in other places situate on the banks of rivers, it is always found necessary to make use of a pump in order to raise the water to the level of the town.

But this peculiarity is, on the other hand, favourable to the formation of lakes. There being no outlet to the superfluous waters which the soil cannot absorb, they are necessarily collected in the flat parts of the country, where they spread to a great extent, covering an immense space, but of no great depth in any part. Most of the lakes which are to be found in this extensive country are of this description. Of these, the celebrated lake of Los Xarayes is formed by the collected waters which fall during four months from the beginning of November to the end of February in the northern provinces, and in the mountainous districts in which the Paraguay has its sources. This great river, swelled by the tropical rains, soon overflows its banks, and its redundant waters spread to a great extent over the flat country through which it flows. As the quantity of rain which falls in different years varies considerably, the dimensions of Lake Xarayes, which is formed by the overflowing of the river, are liable to great uncertainty. In general, however, it is found to extend beyond the 17th degree of south latitude, and about this point its breadth on the east of the river Paraguay is about 66 miles. It preserves the same breadth for about 300 miles to the north, surrounding with its waters several islands which are covered with lofty trees. On the west side of the river, the breadth of the lake is not so considerable. Its whole length, according to the nearest estimate, may be 330 miles, and its breadth on an average 120 miles. But although it spreads over so large a space, it is not navigable in any part except for canoes and small craft. When the rainy season abates, the waters of this lake subside into the channel of the Paraguay, leaving the whole plain perfectly dry, and covered with weeds and other plants. The number of crocodiles in this lake is immense, and in the vicinity are found tigers, leopards, stags, and monkeys of various kinds; the country also swarms with ants, mosquitoes, and innumerable noxious insects. During the inundation, the Portuguese, from their settlements on the Cuyaba, cross the lake in canoes and small barks. There are various other lakes of the same description in Paraguay, such as that of Aguacaty in the 25th degree of latitude; those which are found to the south and north of the lake

Buenos
Ayres.

Buenos
Ayres.

of Ypoa, situated in the 26th degree; that of Neembucu at the 27th; all those which lie on the eastern banks of the Paraguay, besides an infinite number of others of more or less extent, on the banks of all the streams and rivulets which run through the vast plains of this level country.

All those more permanent collections of water, which depend not for their existence on the supply from the periodical rains, are in like manner spread over extensive flats, and they have in consequence little depth. Of this sort, there is a great number, both large and small, scattered throughout different parts of the country. The most considerable are the lakes of Mandiha, situated in 25° 20' of south latitude, that of Ypacarary, situated in 25° 23', and the Iberi, to the south of the Parana, between the 20th and 29th parallels. This lake is of an irregular figure, nearly 200 miles in length, but little more than 46 in breadth. It gives rise to three rivers which, issuing from its south-west extremity, fall into the Parana, namely, the St Lucia, Batela, and Corrientes, and also to the river Mininay, which, taking a south-east course, falls into the river Uruguay. It is shallow, and filled with aquatic plants, which greatly obstruct the access into the interior. The immense expanse of its waters is diversified by several islands, which are covered with wood, and abound in deer and other game. It produces a continual supply of fish, which are remarkably sweet and fresh, and abundance of wild fowl are found on its surface. This lake overflows twice a-year; its environs are fertile and beautiful, and they are enlivened by the flourishing settlements, now called Presidencies, which have been established on its shores.

In the late additions which have been made to the viceroyalty of Buenos Ayres, from the kingdom of Peru, the lake Titiaca, or Chucuito, appears to be included. It is situated between the two Cordilleras of Peru, in the north-western part of the province of Los Charcos, and, being formed by the accumulated waters of the surrounding mountains, which have no outlet, it differs entirely from the lakes which are to be found in the flat parts of the country, being in some parts from 70 to 80 fathoms in depth. It is about 240 miles in circumference, and is navigable for the largest vessels, but is subject to storms, owing to the winds which descend in tremendous gusts from the neighbouring mountains. It is frequented by immense flocks of water-fowl; and its shores are covered with flags and rushes, which serve for many purposes of domestic manufacture. It contains several islands, of which the largest is Titiaca, from which this lake derives its name. The banks are crowded with towns and villages, which are considered the most pleasant residences in the country. Helms, who travelled by this route from Buenos Ayres to Lima, mentions, that, after quitting the banks of the Plata, he did not meet with any country, in the whole course of his journey, so pleasant and picturesque, as that which bordered on this lake. The hills and dales appeared agreeably intermixed with the richest meadows, on which were feeding numerous herds of cattle, mules, horses, and sheep.

The vast plains of which so great a proportion of this viceroyalty consists are many of them fruitful; and, in the vicinity of the Spanish settlements, where they have been cultivated, they yield abundant crops of excellent corn, and other productions, while others afford pasture for numerous flocks of sheep. From the banks of the Paraguay, immense plains extend westward to the limits of the province of Los Charcos, and to the mountains that rise far to the north. These are in general elevated and dry, though traversed by numerous rivers. They are skirted by extensive and ancient forests, which afford shelter to the wild animals of the country, and they are inhabited by scattered tribes of Indians, who roam over their trackless deserts in a state of savage independence. One continued plain, in like manner, extends from the banks of the Plata to Chili, and to the large rivers of Patagonia. These plains are called the *Pampas*, and they present one uniform expanse of waving grass, uninterrupted either by wood or eminence for about 900 miles. The luxuriant herbage of those fertile districts affords pasture to innumerable herds of cattle, which rove about over a great portion of South America, and which are principally sought after by the Spanish hunters for their hides and tallow. The same circumstance has also favoured the multiplication of wild horses, which are so numerous in the plains, that travellers are often surrounded with them for the space of several weeks; and while they are passing them in troops, at full speed, which frequently happens for hours together, the party are in the greatest danger of being run over and trampled down. Here are also found deer, as well as great abundance of ostriches, armadillos, wild geese, ducks, partridges, and other game, and towards the frontiers, guanacoos and vicuñas are met with in considerable numbers. These regions are not well watered; for, though the rivers Saladillo, Hueque-Leuvu, and the first Desaguadero, otherwise called Rio Colorado, run through them, the country is traversed by no smaller streams running into those main rivers; so that they hold their solitary course through the arid plains; and no water is to be found, except what is collected in the pools when the rain falls.

This country, though neither inhabited by Indians nor Spaniards, is occasionally traversed by both; by the former in hunting or in predatory excursions, and by the latter in journeying from Mendoza to Buenos Ayres, or in hunting expeditions. There is a route across the *Pampas* to Chili; but no stations have been established for the accommodation or protection of travellers, who are exposed, in consequence, to the attacks of the savage Indians. As there is frequently no beaten track for hundreds of miles, nor any traces by which the road can be discovered, the journey across the level country is often pursued by the compass. In travelling, covered carts are made use of, which are constructed with all the accommodations of a house, having doors to shut, windows on each side, and mattresses laid on the floor, on which the travellers sleep for the greater part of the journey. In general, they begin travelling about two hours before sun-set, and continue all night, until an hour after

Buenos
Ayres.
Immense
Plains call
ed Pampas

Mode of
travelling
across the
Pampas

Buenos
Ayres.

sun-rise in the morning. In the course of this journey, the party are exposed to many dangers and inconveniences. Of these the want of water is the most serious evil. It is always necessary to carry a supply with them, both for themselves and their cattle; but when this fails, they suffer the greatest distress, unless fortunately a shower of rain comes to their relief. The excessive heats during the day are also greatly complained of. Against these the caravan affords no adequate shelter, nor does it protect its inmates against the rains, which often fall in excessive quantities. The inconceivable fury of the westerly winds, which sweep across the *Pampas* without any interruption, presents another obstacle to the progress of the traveller. There is a road established across the country from Buenos Ayres to Lima, which is more frequented than the route to Chili. On this road regular stages were established in the year 1748, post-houses were erected, and relays of horses and carriages were provided, for the accommodation of travellers. It is likewise free from all danger of attacks from the Indian tribes, who, in their predatory incursions, seldom advance so far within the precincts of the Spanish territories; and it is only in the first stages that it is thought necessary to place troops at the different stations for the security of travellers. This was the route pursued by Helms, the German Mineralogist, who has published an account of his journey. In traversing the mountainous districts of the Andes, the party were exposed to the most sudden and dangerous vicissitudes of heat and cold, sometimes oppressed by the scorching heat of the deep valleys through which the road wended, and within the space of a few hours shivering in the regions of everlasting ice and snow.

line
ains.

There is a very large tract of country in the extensive plains of South and North America, of which the soil is saturated with fossil salt. In this viceroyalty the saline plains extend about 600 or 700 miles in length, and 150 in breadth. It has been generally observed, that, in all the country westward of the Paraguay, in all that tract which is comprehended under the denomination of the Chaco, and in the country also to the south of the Plata, from Cape St Anthony on the south to the Rio Vermejo on the north, there is not a single rivulet, lake, or well, which is not of a brackish taste during the heats of summer, when a quick evaporation takes place, or during a long course of dry weather, when no rain falls to correct, by its freshness, the natural saltiness of the rivers and springs. All the rivers that flow from the western Andes yield excellent water, until they reach the salt territory, after which their waters are not fit to be drunk until they reach the Parana. Even the great rivers the Pilcomayo and the Vermejo have a brackish taste during the dry season, when their waters are low. The rivers and springs are, however, more impregnated with salt in some parts than in others. The fort of Melincue, which is situated about 33° 44' S. lat. and about 150 miles to the north-west of Buenos Ayres, is almost entirely surrounded with salt lakes, which are frequently dry when there is a scarcity of rain. Azara mentions that, arriving in

this quarter in the month of March, he found the surface of the ground, for about a league across, covered to the depth of four inches with Epsom salt. To the south-west of Buenos Ayres, about 130 leagues, there is a salt lake always filled with excellent common salt, which is preferred to that of Europe on account of its being entirely free from a slight tincture of bitterness, always supposed, in these countries, to adhere to European salt. In the neighbourhood, at the distance of from 400 to 450 miles, there is an abundance of salt lakes, which produce very fine crystalline-grained salt. These lakes are large and broad. Some of them are surrounded by woods to a considerable distance; and their banks are white with salt, which needs no other preparation than an exposure for some time to the heat of the sun. Journeys are undertaken from Buenos Ayres to this part of the country, for the purpose of procuring salt, and from 200 to 300 carts are annually loaded with it for the supply of this city. Numerous salt-lakes of the same description occur in the neighbourhood of the river Vermejo, and in the Chaco to the west of the Paraguay. At the city of Assumption, situated on the Paraguay, in latitude 24° 47' south, and longitude 59° 35' west, a considerable quantity of salt is refined from the earth. Between Santa Fe and Cordova, a still greater quantity is produced, and this quality of the soil reaches to St Jago del Estero, where the whole ground is covered with a white incrustation of salt, and even quite across the barren and desert plain which extends westward to the foot of the Cordillera. Natural saltpetre is also produced in this country in great abundance. After a shower of rain the ground appears white with it, so as to chill the feet excessively. A small quantity, however, is only collected, no more than is sufficient to manufacture fire works for the amusement of the converted Indians, at the religious festivals of the Romish church.

Buenos
Ayres.

In this country, as in Brasil, and other parts of America, the cattle are accustomed to receive salt as part of their nourishment. In the province of Paraguay, they eat a sort of salted clay which they find in the ditches, and when this fails, which sometimes happens in the eastern cantons of this province, and in the missions on the banks of the Uruguay, numbers of cattle perish in the space of a few months. It is incredible with what avidity they feed upon this singular nutriment, and when they have wanted it for some time, no inducement, not even blows, will tempt them to quit the place where they have found it.

The western parts of this viceroyalty, more especially the provinces which were added from Peru, are generally mountainous, comprehending within their limits some of the highest ridges of the Andes. The province of Los Charcos includes a considerable proportion of the two principal chains that run from north to south along the eastern part of Peru, and between which lie the elevated plains of Cuzco, with the districts of Los Charcos, rugged and barren, but rich in mineral treasures. From the great chain of the Andes, branches diverge in different parts, and extend far into the interior. Of these, the mountains of Cordova and Achala, in the province

Buenos Ayres.

of Tucuman, and those of the more westerly province of Cuyo, form secondary ridges; and another ridge of this nature branches off in the latitude of the great river Colorado, which, under the Indian appellation of Casuhati, runs nearly across to the Atlantic. These southern mountains are covered with thick impenetrable woods, and are little known. The eastern mountains, which form the Brazilian ridge, are also of secondary elevation. They are generally covered with thick forests, interspersed with extensive tracts wholly devoid of vegetation. They form a cluster of mountains towards the interior provinces of Minas Geraes and Matto Grosso, by which the tributary streams of the great river of the Amazonas are divided from those which run south into the Plata. Different ridges diverge from them to the north and south, and the main chain extends quite across the Continent, taking a north-westerly direction towards Santa Cruz, de la Sierra, and Potosi, and thus uniting with the great ridges of the western Cordillera. In this mountainous district, the summits of the Andes rise above the regions of the clouds, and are covered with eternal snows. In the lower parts of the mountain, where the snow is only occasional, sterile tracts of sandy deserts appear, which are bordered with various kinds of lichen that grow in crevices. To this imperfect vegetation succeeds a wiry kind of grass or rush, the natural food of the guanacos and the vicunnas which haunt those upland deserts. The mountains of secondary elevation are covered with stately forests, and the embosomed vales which are interspersed amongst them, though frequently of a higher elevation than the summits of the Pyrenees, enjoy from their sheltered situation a temperate and favourable climate, which adapts them to the production, in great abundance, of all sorts of European fruits and grain. In many of those valleys, apples, peaches, cherries, plumbs, grow to great perfection. Wheat is cultivated with success, and there are extensive natural pastures, which afford herbage for large herds of cattle and flocks of sheep.

Productions.

In the lower districts of the country, and in the plains, wheat, maize, cocoa, grapes, oranges, citrons, figs, olives, and sugar-canes, are among the most common productions; and the herb paraguay, or matté, which furnishes the favourite beverage of all ranks, with the exception of the European Spaniards, is yielded in great abundance. This herb, which is called the tea of Paraguay, is drunk as an infusion, and the Creoles are so passionately fond of it, that they never travel without a supply of this favourite refreshment. About 100,000 arrobas of this plant, of 25 lbs. each, are annually exported from Paraguay to Peru. The value of each arroba is estimated at L. 1, 3s. 4d. Sterling, which makes the annual value of this merchandise sent to Peru equal to L. 116,666. There are, besides, great quantities sent to Buenos Ayres from the city of Assumption, of which this herb constitutes one of the principal articles of export.

Roads and Bridges.

The route from Buenos Ayres to Potosi, which is 1617 geographical miles, and from Potosi to Lima, which is an additional 1215 miles, passes over the highest ridge of the Andes, and, according to the account of Helms, who crossed the continent by it

to Lima, the traveller who undertakes so arduous a journey must expect to meet with every sort of privation and hardship; not only from being exposed to the utmost extremes both of heat and cold, but from the rugged and impracticable nature of the country through which he has to pass. It is only during the summer that the passage across the Andes can be attempted, and as this is the season when the mountain snows begin to melt, the streams which rush down the declivities of the Cordilleras are swelled to impetuous torrents. And this often happens so suddenly, that the unfortunate traveller has no time to escape from the fury of the stream, but is swept down with his mule, and perishes miserably amid the precipices and dark abysses through which the foaming waters take their rapid course. To facilitate the passage across those rivers, wooden bridges are frequently constructed, of sufficient breadth to admit the passage of a traveller on horseback; but where the river is too broad for the construction of those bridges, other bridges are thrown over of a slighter construction. These are formed of a thin elastic cane, called *bijuco*, and from thence they have received the name of *bijuco* bridges. Several of these canes are twisted together so as to form a large cable of the length required. Six of these being stretched from one side of the river to the other, two of which are considerably higher than the other four, sticks are laid in a transverse direction over the lower four, and over these branches of trees. The two uppermost ropes are fastened to the others that are lower, so as to serve as rails for the security of the passengers, who would otherwise be in no small danger from the continual oscillation. These bridges are only for men, the mules being taught to swim across the rivers. But where the rapidity of the torrent, and the large stones which it continually rolls down, render it impracticable for mules, a contrivance is adopted for passing them safely across, named a *tarabita*. This consists of two ropes made of *bijuco*, or of thongs of an ox-hide twisted together to a proper thickness. These ropes, being extended across the river, are fastened on each bank to strong posts, and the animal being slung in a sort of leathern hammock which depends from the ropes, and properly secured by girths round the belly, neck, and legs, is drawn to the opposite shore by means of ropes fastened to the hammock and extending to both sides of the river. For the carrying over men or baggage only one rope is required, and on one side is a winch or wheel by which it may be either tightened or slackened as circumstances may require.

In those upper regions heat and cold depend, it is well known, not so much on the geographical position of any particular place, as on its height above the level of the sea. In South America, accordingly, which is distinguished above all other countries by the prodigious elevation of its soil, we find everlasting ice and snow under the rays of a tropical sun; and throughout the whole tract of this elevated country the climate is uniformly modified by the height of the land. In the low country, on the other hand, the distance from the equator fixes the climate; and the extensive and unsheltered plains are ex-

enes
res.

posed to the most scorching heats, more especially those towards the south. At Assumption, the capital of Paraguay, which is situated in 25° 16' 40" of south latitude, it is stated by Azara that, in ordinary summer weather, Fahrenheit's thermometer rose, within doors, to 85 degrees; and that, during the greatest heat of the season, it rose so high as 100. During the winter, in weather which would have been called cold, it fell to 45; but in seasons when the cold was unusually severe, such as in the years 1786 and 1789, the water was found frozen in a court adjoining his house. The nature of the weather depends, in a great measure, on the prevailing winds. It is generally remarked, that a south or south-east wind brings cold weather, and that the weather is hot when the wind blows from the north. This last is the most prevailing wind, the southerly wind not blowing, at the most, for more than a twelfth part of the year. The west wind is scarcely ever known, and, if it is sometimes felt, it scarcely continues for two hours together.

At Buenos Ayres, which is situated in south latitude 34° 35', the weather is, of course, colder than at Assumption; and it is considered as an ordinary winter in which there are only three or four days when water is slightly frozen. Here, and on the coast, the winds are greatly more violent than in the interior. The west winds, which have been already noticed, are more frequent; and those from the south-east, while they always bring rain in winter, are accompanied with clear weather in summer. The violent winds, which prevail both in summer and spring, raise clouds of dust which penetrate into all the apartments of the houses, and greatly incommode the inhabitants. Hurricanes are rare; but they sometimes occur. In the year 1799, the settlement of Atira in Paraguay was thrown down by one of them; thirty-six persons were killed, many carriages were blown away, and various other destructive consequences were experienced. The atmosphere is everywhere filled with moisture, by which the furniture of the houses is injured. At Buenos Ayres, all the apartments which have a southern exposure have the floors continually damp; the walls are also covered with moss, and the roofs with a sort of bushy grass, three feet in height, which must be cleared away every two or three years, to prevent the moisture from sinking down into the house. This moisture of the atmosphere does not appear to be in the least degree prejudicial to the health of the inhabitants. In no country is thunder and lightning more violent. The peals of thunder succeed each other with such rapidity, that there seems hardly an instant between them, and the whole heavens appear as if they were illuminated with one flame. These thunder-storms are frequently fatal to individuals; and in one of them, which happened in January 1793, the lightning struck the town of Buenos Ayres in thirty-seven places, and killed nineteen persons.

The precious metals, which form such an important article of commerce in this viceroyalty, are entirely derived from the western provinces, which lie on the eastern declivity of the Cordillera, and which, in 1778, were separated from Peru. The following enumeration of the mines presently worked

was extracted by Helms from the records of the chancery.

Buenos
Ayres.

Districts.	Gold.	Silver.	Copper.	Tin.	Lead.
Tucuman	2	1	2		2
Mendoza		1			
Atacama	2	2	1		1
Caranges		2	1		
Lipes	2	1	1		1
Porco	1	2	1		
Potosi		1			
Pacages or Benenguela		1			
Chucuito		2			
Puno		1			
Lampa		2			
Chicusy					
Tanija	4	5			1
Cochabamba	1				
Sicasica	2				
Lavicaja	4				
Ouasuyo	4				
Avanguro	3				
Carabaya	2	1			
Chayanza	2	3	1	1	1
Misque		1			
Paria		1		1	1
Monte Video	1				

An account of the accidental discovery of the rich Silver Mines of Potosi will be found in the *Encyclopædia* under the article *PERU*. In 1545, the first mine was formally registered. Another was discovered some days afterwards. A third, surpassing the two others in wealth, was distinguished by the name of Rica, which, with a fourth, were soon worked with great activity. The mountain, which at the base is 18 miles in circumference, is pierced everywhere by the operations of the miners. According to Helms, who visited Potosi in 1789, above three hundred pits were at that time worked; but those who directed these works seemed totally ignorant of the first principles of mining. Few of them penetrated to a greater depth than 70 yards, and they were all of them worked as irregularly, as if it had been merely for plunder. Many of the pits were inundated with water; to free them from which, a main conduit had been begun in 1778, which, in the course of nine years, had, at an incredible expence, been carried two miles in length. But so unskilfully had this important work been planned, that even at its mouth the conduit was above the level of the water in many of the mines, after which it rose about one yard in every thirty-two, which rendered it still more inefficient. Eight new veins were intersected by this conduit, some of them containing very rich silver ores. Another conduit was inspected by Helms and the other German Mineralogists who accompanied him, which was begun about 100 years before, and which led to many rich veins of red and grey silver ore. For want of proper machinery, however, all the pits were filled with water; though, under better management, they might have been:

Buenos
Ayres.

made to yield a considerable revenue to their proprietors.

The one from which silver is extracted is various in its nature, consistency, and colour. The mountain of Potosi consists chiefly of a yellow, very firm argillaceous slate, full of veins of ferruginous quartz, in which silver ore, and sometimes brittle vitreous ore, are found interspersed. There is also a greyish brown one, in which appear some small grains, and thin branches or veins of silver, running along the layers of stone. This ore is extremely rich, yielding for each caxon, or 50 hundred weight, 20 marcs of silver or about 13 lbs. Some of the ores which are found in other provinces of this viceroyalty appear black, frequently from the admixture of lead. The silver is seen when the ore is scratched. These ores are called *negrillos*, from their colour, and are esteemed very rich, yielding 50 or 60 marcs of silver per caxon. They are more valued also on another account, namely, that the silver is extracted from them at a small charge. In place of the usual process of amalgamation with quicksilver, they are merely melted in furnaces, where the lead, being evaporated by the fire, the silver is left pure and clean. There is another sort of rich ore, containing a large proportion of the finest silver, which turns red if it is wetted and rubbed against iron. Some of the ores glitter like talc. These yield but little silver; but, being soft, the metal is easily extracted from them. Some are green, from the admixture of copper, which it is found troublesome to separate from the silver. But the most scarce and valuable ore is that which appears in entangled threads of pure silver, so fine that it is called *arana*, from its resemblance to a spider's web.

The veins of silver frequently run through hard rocks, which have to be reduced to a very fine powder before the ore can be fit for the process of amalgamation. In order to render the ore more friable, it is frequently roasted or calcined in an oven. It is afterwards broke to pieces with iron mallets, after which it is carried to the mills, where, being ground to a very fine powder, it is passed through several wire sieves successively, the last being the finest. The rude ores are also frequently broke to pieces by hammers lifted up and down by means of a wheel. These hammers weigh about 200 pounds, and fall with sufficient violence to reduce the hardest stones to powder. This powder is laid in wooden troughs, and is kneaded with quicksilver and water, until the two metals are completely amalgamated, after which the quicksilver is evaporated by distillation, and the metal which remains is cast into ingots.

In some of the smaller rivers, mills with grindstones are used. The ore is ground with water, which makes a liquid mud, that runs into a receiver. The mud is disposed on the floor in square parcels about a foot thick, each of them containing 25 hundred weight of ore. On each of these about 200 weight of sea-salt is thrown, which is moulded and incorporated with the earth for two or three days. After this the quantity of quicksilver which they judge necessary is added to the mass, which is moulded eight times a day, and lime is frequently mixed with it, to accelerate the process of amalga-

mation. In the elevated and cold regions of Potosi and Lijas, this operation requires a month or six weeks before it is completed. But, in warmer districts, it is finished in eight or ten days.

The manner in which these and all the other operations are performed, by which the precious metals are extracted from the earth, and afterwards separated from their ores, is censured, in the most unqualified terms, by Helms. After pointing out the ignorance which prevailed in the previous management of the mines, "still greater, if possible (he observes), was the ignorance of the Directors of smelting-houses and refining works at Potosi. By their method of amalgamation they were scarcely able to gain two-thirds of the silver contained in the rude ores; and for every marc of pure silver gained, they destroyed one, and frequently two marcs of quicksilver. Indeed, all the operations at the mines of Potosi, the stamping, sifting, washing, quickening, and roasting the ore, are conducted in so slovenly, wasteful, and unscientific a manner, that, to compare the excellent method of amalgamation invented by Baron Bern, and practised in Europe, with the barbarous process used by these Indians and Spaniards, would be an insult to the understanding of any readers."

"The tools of the Indian miner (he continues) are very badly contrived and unwieldy. The hammer, which is a square piece of lead of 20 pounds weight, exhausts his strength,—the iron, a foot and a half long, is a great deal too inconvenient, and, in some narrow places, cannot be made use of. The thick tallow candles, wound round with wool, vitiate the air."

The same mismanagement prevailed in the Royal Mint, where every hundred weight of refined copper used for alloy in the gold and silver coin cost the King L. 35 through the ignorance of the overseers, who spent a whole month in roasting and calcining it, and in the course of these tedious operations frequently made it unfit for the purpose to which it was intended. Mr Helms was ordered by the Governor to introduce a more improved process for the refining of the copper, and he accordingly showed, by actual experiment, that copper could be brought to a greater degree of fineness in four hours and a half, and at less than $\frac{1}{10}$ th of the expence. The other evils in the management of the mines, he also attempted to reform, in conjunction with another person of skill in the mining art, who accompanied him to South America for the same purpose. In order to free the mines from water, two deep conduits were dug in the mountains; proper machines were erected; amalgamation works were set on foot, and the necessary instructions in metallurgy were given to six pupils, for the purpose of enabling them to reduce this improved system to practice. If the water in the pits can be drained, the mines of Potosi would be in as flourishing a condition as ever. The total want of timber, however, on the naked ridge of mountains in which these mines are situated, tends greatly to retard the progress of the work.

Respecting the quantity of silver which has been extracted from the mines of Potosi, various accounts have been published. But these have generally been founded on imperfect materials, and their accuracy is therefore liable to doubt. On this point,

Humboldt's invaluable work on the kingdom of New Spain, contains the most complete and satisfactory information. This celebrated traveller was enabled to procure, from official papers, an account of the value of the royal duties paid into the provincial treasury of Potosi, on all the silver brought to the mint between the years 1556 and 1789; and the proportion of those duties to the whole produce being known, the annual amount of the silver extracted from the mines, during this period, with the exception of what was carried away by the contraband traders, can be easily ascertained from these accounts. From the year 1545 to 1556, there are no records of the royal duty, and Humboldt has supplied this defect from such imperfect and accidental information as he could collect in the works of the earlier writers on South America. Ulloa, who proceeds upon the authority of a writer in the 17th century, estimates the silver produced, during those eleven years, when the official records are wanting, to 72,000,000 of marcs, equal to about L. 144,000,000 Sterling. But, according to the more accurate reckonings of Humboldt, this estimate must be greatly above the truth; and he conjectures that the whole produce during this period, cannot have exceeded 14,000,000 of marcs or 127,500,000 piastres, equal, valuing the piastre at 4s. 2½d. to L. 26,328,125 Sterling. He states, however, that little reliance can be placed on the correctness of this estimate.

From the year 1556 to the year 1578, a duty of one-fifth was paid on all the silver brought to the mint of Potosi. These duties amounted, during this period of twenty-three years, to 9,801,906 piastres, which gives a total produce for these twenty-three years, of 49,009,580 piastres, or 5,765,827 marcs of silver, equal to L. 19,312,481.

From the year 1579 to the year 1736, including a period of 158 years, a duty of 1½ per cent. was paid, and afterwards the fifth of the remaining 98½ piastres, which amounted to nearly 6½ per cent. The produce of this duty for 158 years amounted to 129,417,273 piastres, which gives a total produce of about 610,452,822 piastres, or 71,212,626 marcs, and an annual average produce of 8,888,272 piastres, or of 455,291 marcs, in value equal to something more than L. 8,000,000 Sterling.

From the year 1736 to 1789, 1½ per cent. of duty, and the half of the fifth were paid, and, during this period of fifty-three years, the duties amounted to 14,522,684 piastres. The whole produce amounted consequently to 128,189,374 piastres, or 15,074,044 marcs of silver, and the annual average produce to about 281,748 marcs, equal to about L. 490,000.

From 1789 to 1803, there is no account of the royal duties. But, according to the records of the mint, the produce amounted to 46,000,000 of piastres, or to 3,225,710 piastres per annum. Helms, who visited Potosi in 1789, states that there were annually coined in the royal mint from 350,000 to 600,000 marcs of silver, and about 2000 marcs in gold.

According to these calculations, the quantity of silver yielded by the mines of Potosi, amounts

Buenos Ayres.

	Piastres.	L.
For 11 years, from 1545 to 1556, to	127,500,000	26,828,125
For 23 years, from 1556 to 1578, to	49,009,580	10,312,481
For 158 years, from 1579 to 1736, to	610,452,822	128,450,713
For 53 years, from 1736 to 1789, to	128,189,374	26,960,554
From 1789 to 1803, to	46,000,000	9,679,166
In this account the piastre is estimated at eight reals, or 4s. 2½d. Previous to the year 1600, it contained 13½ reals de Plata. For this add two-thirds to the produce of these years, about	250,000,000	52,604,166
The allowance for contraband is variously estimated at a third, a fourth, and a sixth. Estimating it at one-fourth, it will amount to	302,774,434	63,708,780
	1,211,097,789	254,835,155
Add for contraband, } one-fourth, }	302,774,434	63,708,780
Total produce, -	1,513,872,173	318,543,935

From this estimate of the produce of these mines, it will be found that they were never more flourishing during the whole period of 233 years, from 1556 to 1789, than from 1585 to 1606. For several successive years, the royal fifth amounted to one and a half million of piastres, which supposes an annual produce of 1,490,000, or 882,000 marcs, according as the piastre of silver is estimated at 13½ or 8 reals.* This is the more surprising, as at this period more than a third of the silver was never registered. Adding this one-third to the annual produce calculated from the royal fifth, the quantity of silver produced at this time, will amount to 10,000,000 of piastres, equal to L. 2,104,166. After the year 1606, the produce began gradually to diminish, although from this time to 1688, it never was below 350,000 marcs per annum. From the commencement of the subsequent century, the produce continued decreasing, and from the year 1736, when the royal fifth only amounted to 85,410 piastres till about the year 1748, the annual amount of the duties was never equal to 200,000 piastres. After this period, the produce began to increase, and gradually rose to between 300,000 or 400,000 marcs. This quantity, however, Helms, who had the best opportunities of information, assures his

* This coin, towards the conclusion of the sixteenth century, was reduced to the value of eight reals; and as it is uncertain when this change took place, we cannot exactly ascertain the quantity of silver which was produced at this period. We can only be certain of its highest and lowest quantity.

Buenos
Ayres.

readers could be doubled, if the mines were drained of the water with which they are overflowed, and if some other simple improvements, which he suggests, were carried into effect.

In 1545, it is mentioned that ores containing from 80 to 90 marcs *per* quintal of 1600 ounces, were common. The marc is nearly equal to about eight ounces; so that, according to this account, 1600 ounces of ore were found to yield about 600 or 700 ounces of silver. The average produce was, at this period, from eight to nine ounces *per* quintal, which was nearly in the proportion of one ounce in twenty-two or twenty-five. Since the commencement of the eighteenth century, it is stated by Humboldt, that they reckon only on extracting from three to four marcs of silver from the caxon of ore, equal to 5000 lbs. which is only one ounce of silver out of every 2000 or 2500 ounces of mineral. According to experiments made by Helms on 300 specimens of ores, they were found to produce from six to eight ounces of silver for every caxon of 5000 lbs.; although in some ores the silver was in the proportion of 20 marcs to each caxon, which is about one in 384.

The minerals of Potosi are consequently extremely poor, and it is owing to their abundance alone, that they still produce so great a quantity of silver. From 1574 to 1789, the mean quantity of silver afforded by the ores has diminished in the proportion of 170 to one, while the silver extracted from the mines has only diminished in the proportion of four to one. It thus appears that the productiveness of mines does not by any means depend so much on the richness or poverty of the minerals which they contain, as on their abundance, and the facility with which they are worked. It happens, accordingly, that the Mexican mines, which are the richest in the world, contain remarkably poor minerals, the best yielding, on an average, from $4\frac{8}{10}$ to $5\frac{3}{10}$; the middling from $1\frac{2}{10}$ to $2\frac{7}{10}$, and the worst about $1\frac{3}{10}$ ounces of silver for every 1600 ounces of ore. In some of the mines of Germany, on the other hand, of which the produce falls so far short of those of South America, the mean proportion of silver is found to amount to 10 ounces *per* quintal, and in fortunate periods to 15.

From 1545 till 1571, the silver minerals of Potosi were all smelted in portable furnaces contrived by the Indians. These were cylindrical tubes of clay, very broad, and pierced with a number of holes, which, admitting the air, gave the flame a great degree of intensity. About the year 1571, the method of amalgamation with mercury was introduced; and of the 8000 or 10,000 quintals produced by the mine of Guancunelica towards the end of the sixteenth century, above 6000 or 7000 quintals were consumed in the works of Potosi. About the year 1763, the consumption amounted to between 16,000 and 17,000 quintals annually. There are at present 2000 miners engaged in the works at Potosi, who are paid at the rate of 25s. *per* day. Fifteen thousand llamas, and an equal number of asses, are employed in carrying the ore from the mountain of Potosi to the amalgamation works.

Gold
Mines.

Gold is found in most of the mountainous districts of this viceroyalty. It is either worked in mines,

gathered from the sands, or collected from the streams. Near the town of Mojos, there is a considerable stratum of rich magnetical iron sand, in which are found particles of gold of the size of a lentil, and sometimes as heavy as the quarter of a ducat. The Indians, however, by their unskilful mode of working the sand, lose all the finer particles of the gold, which are carried away by the stream. From the town of Mojos to within a short distance of Potosi, from which it is distant 180 miles, similar alluvial layers occur, and gold is washed from them, especially at the little town of St Jago de Cotagoita, which is distant about 90 miles from Potosi. In the province of Lipes there are gold mines, many of which have been abandoned. But two are now worked, and one of copper, the strata of which are intermixed with gold, silver, iron, and loadstone. In Puno and Oruro, there are several gold mines. But most of them have gone to decay from the inactivity of the inhabitants, or they have been overflowed, and all efforts to drain them have been found unavailing. The most abundant mines are in the province of Cochabamba and Sicaica. The whole of the mountains in this last district, where the Indians collect ore by working, abound in rich gold ore, and when, about a hundred years ago, a projecting part fell down, lumps of pure gold, weighing from two to fifty pounds, were severed from the stone; and, even in the present times, in the layers of sand washed from the mountain by the rain water, pieces of pure gold are found, some of which weigh an ounce. From the ignorance of the inhabitants, however, most of these treasures lie totally neglected.

A very brief and general account of the animals of this country, is all that can be attempted within our present limits. The horses and horned cattle, originally imported from Europe, have multiplied amazingly in the extensive plains of South America. Asses, mules, European sheep, stags of different species, foxes, rabbits, goats, and hogs, are numerous, and great numbers of wild dogs are to be met with. These are descended from those of a domestic kind that have left their masters in pursuit of the game, with which the country everywhere abounds. The other wild animals are the puma or American lion, the jaguar and cougar, two species of American tigers, which are strong and ferocious animals, and commit great devastations among the flocks. The jaguar, when full grown, is a large animal, some of them measuring five feet from the nose to the root of the tail, which is two additional feet long, and so strong that they will drag the carcass of a horse or bull which they have killed to the place where they intend to devour it. They are excellent swimmers, and Azara mentions, that he has seen them swimming across a large river loaded with their prey. The Puma is a weak and cowardly animal, and is now become very scarce in the parts inhabited by the Spaniards. The guazuara, called the cougar by Buffon, is 47 inches long, without including the tail, which is 26 inches long. It flies from the human species, but kills calves, sheep, pigeons, and all other smaller animals. It does not stop to eat the flesh, but is contented with licking the blood. Of the other animals, the most remarkable are the asta or danta, which is between the elk and buffalo

uenos
Ayres.

Buenos
Ayres.
Fish.

species. It is of the size of a large ass, has no horns, and is of singular strength. It is frequently found in the forests and plains of Paraguay, but has been so much hunted both for its skin and flesh, that it is scarce both in Tucuman and Buenos Ayres. The armadillos are very numerous all over South America, and are of various species, differing in size, and in the nature of the armature with which they are covered. The tamandua, or nurumi, or ant-eater, is 53½ inches long, without reckoning the tail, which is in length 22½ inches, besides a thick bunch of hair at its end, 11 inches long. Azara enumerates various other small animals, which are generally carnivorous, preying upon birds, reptiles, or other inferior quadrupeds. The chibi-guazu, which he considers to be the jaguar of New Spain, or the tiger-cat of other countries, is 34 inches, and the tail 13 inches. Wild cats are found of various sorts. There are also several animals which have the form of the martin, the pole-cat, and the ferret, but which are much larger and stronger. The sarigue or the fe-cundo, is a small animal peculiar to America, which preys upon pigeons, mice, insects, eggs, &c. It has a long triangular and pointed face; its eyes are oblique and jutting out. Its mouth is large, and well furnished with teeth. Its tail is long, thick, and covered with scales, which it uses to climb up trees and walls when the surface is in any degree rough. It has long whiskers, and its ears are round, naked, and transparent.

Of the domestic animals, those most worthy of note are the lama and the paco, both natives of the mountainous parts of Peru, and inhabiting the higher districts of the Tucuman, and the provinces of Los Charcos, and Santa Cruz de la Sierra. The lama is a most useful animal, and is capable of carrying heavy burdens in the most rugged and dangerous roads. It is about four feet high; the body, including the neck, is five or six feet long. This animal bears a great resemblance to a camel, excepting that it has no hunch on its back. The paco, or vicunna, is a species of subordinate animal to the lama, in the same manner as the ass to the horse. Their wool is fine and long, and is a valuable article of merchandise. The natural colour of it is that of a dried rose-leaf; and while every kind of clothing manufactured of it possesses a peculiar degree of genial warmth, it is at the same time most beautifully silky and light. The lama and the paco inhabit the highest mountain-deserts amid perpetual ice and snow; and the cold, far from being unfavourable to them, seems to invigorate and refresh them. The tapir, though more abundant in Brasil, is also found on the banks of the Parana and Paraguay. It is of the size of a small cow, but has neither horns nor tail.

Of birds, the emu, which is generally known by the name of the American ostrich, and the well-known bird of prey the condor, are the most remarkable. The emu is bred in the Pampas. It is generally six feet high, measuring from the head to the feet; and it runs with such swiftness that the fleetest dogs are thrown out in the pursuit. Carrion vultures, which fly in large flocks, are also very common, and feed upon numerous carcases of the cattle slaughtered for the sake of their hides.

The rivers abound in great varieties of fish; and of amphibious animals, there are on the coast turtles, seals, and sea-lions; while alligators or caymans, of a large size, and very voracious, swarm in all the rivers. The interior of the country is infested by innumerable tribes of reptiles and insects, which are brought into life in the damp forests, and on the rank soil on the borders of rivers. Serpents also abound in these parts, among which the most remarkable is the enormous boa constrictor, which is chiefly found in the marshy places of the forests.

In regulating the colonial trade, Spain has uniformly proceeded upon the principle of sacrificing the colony for the supposed advantage of the mother country; and, with this view, such restraints were imposed on the commerce of her South American provinces, as forced them to depend entirely on the parent state, both for the supply of their wants, and for the sale of their produce. They were not only entirely debarred from trading with Europe, or with any other country, in their own vessels, but their intercourse with each other was either entirely prohibited or obstructed by many severe restrictions. Under this system, the commerce of Spain with her colonies centered entirely in the port of Seville; and the cargo of every ship destined for the colonies was inspected by a board appointed for the purpose, before she could receive a licence to make the voyage. In 1720 this commerce was transferred to Cadiz, as being a more convenient port; and the commerce was carried on by means of annual fleets, which sailed periodically, and which consisted of two squadrons, known under the respective appellations of the galleons and the flota. These expeditions were made exclusively to the Gulf of Mexico; and it was through the ports of Porto-Bello and Vera Cruz alone that the colonies of Spain were either supplied with European commodities or found a vent for their own productions. Owing to this limited intercourse, the produce of America was exchanged for that of Europe on terms extremely disadvantageous. Her markets were always imperfectly supplied with the commodities of Europe, which bore, in consequence, a very high price; while her own productions, being restricted to particular ports, were always liable to arrive at a market already overstocked. The Spanish colonies languished under those harassing restrictions; and Buenos Ayres, whose territorial resources consisted neither in gold, silver, indigo, cochineal, nor in any of those precious products which are easily exported, but in bulky and perishable commodities requiring the constant command of shipping, remained for a long time in a state of obscurity and depression.

But the operation of this system was eventually counteracted by its extreme violence and injustice; in consequence of which it was found impossible, in cases where it prohibited the colonies from being supplied with articles of the first necessity, to carry it into strict execution. Salutary evasions were, therefore, connived at, and, in process of time, a contraband trade was established, which was found so beneficial, that it flourished in spite of all the expedients adopted to prevent it. The legitimate

Buenos Ayres.

commerce was proportionably diminished, and the annual squadron gradually dwindled away from 13,000 to 2000 tons of shipping.

Those encroachments on the monopoly of the colonial trade plainly suggested the necessity of relaxing the restraints by which the colonies were oppressed, and of devising some method for ensuring to them a constant and adequate supply of European produce. In the year 1740, a considerable part of the American trade was permitted to be carried on by register ships, which, on purchasing a licence from the Council of the Indies, were allowed to sail at any time, and which, in the year 1748, finally superseded the galleons and flota, after they had been in use for two centuries. By means of this intercourse, the American market was more regularly supplied with the productions of Europe, and Buenos Ayres was benefited, along with the other colonies, by these regulations.

Other relaxations of the system of restraint soon followed. In 1774, a free intercourse was opened between several of the American provinces; and, in 1778, seven of the principal Spanish ports, to which, in 1788, five others were added, were permitted to engage in a free trade with Buenos Ayres, and with the ports of the South Sea. These regulations, together with the erection of Buenos Ayres into an independent viceroyalty in 1778, gave it importance and stability; and, from this period, its imports and exports have progressively increased. Previous to the year 1778, not more than 12 or 15 registered vessels were engaged in the colonial trade of South America, and these seldom performed more than one voyage in three years. But, in that year, their number increased to 170 vessels, the value of whose cargoes amounted to L.1,958,676. For the further encouragement of the trade of Buenos Ayres, salted meat and tallow were allowed, in the year 1793, to be exported duty-free; and, by this and other regulations, the trade and population of the adjacent provinces was considerably increased. Azara gives the following annual average estimate of the trade and shipping of Buenos Ayres, taking the average of the years between 1792 and 1796.

Imports from Spain.

No. of Cargoes.	From what Ports received.	Value of Spanish Manufactures and Productions.	Value of the Productions and Manufactures of other Nations.	Total.
21½	Cadiz	631,615	923,313	1,554,928
21	Barcelona and Malaga	595,229	21,845	617,074
6½	Corunna	223,484	75,584	299,068
3½	St Andero	32,501	24,187	56,688
	Vigo	6,132	4,400	10,532
	Jijon	4,684	2,123	6,807
	St Lucar	287		287
83½				2,545,364

In pounds Sterling, L. 535,587

Exports to Spain.

Buenos Ayres.

No. of Car-goes.	To what Ports sent.	Silver in Piastres, in Ingots, or in Plate.	Value of Gold in Piastres.	Value of Produce in Piastres.	Total Value in Piastres.
19	Cadiz	1,002,557	941,798	447,483	2,391,845
15½	Barcelona & Malaga	260,385	83,281	377,301	561,568
8½	Corunna	938,348	625,696	32,685	1,656,729
3½	St Andero	5,202	1,632	50,189	57,023
47					4,667,166

In pounds Sterling, L. 982,049

Imports from the Havannah.

Sugar	-	13,037	arrobas.
Confections	-	37	ditto.
Honey	-	132	jars.
Cocoa	-	65	arrobas.
Coffee	-	225	ditto.
Brandy	-	1,277	casks.
Rice	-	240	quintals.
Wax	-	505	arrobas.
Pitch and Tar	-	37	quintals.
Linen	-	473½	pieces.
Manna	-	96	pounds.
Dye-woods	-	37½	quintals.
Acuna wool	-	188	ditto.

Value in pounds Sterling, L. 20,397.

Exports to the Havannah

Silver in piastres	-	17,236.
Salt Beef	-	39,281 quintals.
Tallow	-	10,617 arrobas.
Fine furs	-	147
Sea-wolf skins	-	323
Common wool	-	80 arrobas.
Sheep skins	-	113 dozen.
Flour	-	440 quintals.
Oil of the sea-wolf	-	25 ditto.
Copper	-	50 ditto.
Goose wings	-	70

Value in pounds Sterling, L.15,057.

Imports from Lima.

Sugar	-	4337	arrobas.
Cocoa	-	295	do.
Cinnamon	-	75½	pounds.
Rice	-	80	quintals.
Salt Stones	-	200	
Indigo	-	133	pounds.
Wrought iron	-	7	

Value in pounds Sterling, L.526½

Buenos Ayres.

Exports to Lima.

Paraguay tea	-	-	2688 arrobas.
Tallow	-	-	2800 do.
Swan skins	-	-	20
Negro slaves	-	-	83
Hoes	-	-	419
Thread	-	-	128
Silk stockings	-	-	8
Hats	-	-	24

Value in pounds Sterling, L.4725.

Imports from the Coast of Africa.

Negro slaves	-	-	1338
Hoes	-	-	1420

Value in pounds Sterling, L.66,705.

Exports to the Coast of Africa.

Silver, in piastres	-	120,276
Value of goods	-	12,738

Value in pounds Sterling, L.27,987.

Effects of the War with England on Commerce.

In the year 1797, hostilities commenced between Spain and Great Britain; and, in consequence of this event, the trade between the mother country and her South American colonies was necessarily exposed to the maritime hostility of Britain. So effectually was this hostility carried on by the British cruisers, that, in 1798, the trade of the Spanish settlements was at a stand; and it was calculated that above three millions of hides were lying at the warehouses of Buenos Ayres and Monte Video, for which no vent could be found. European goods were totally wanting, or had risen to excessive prices. Linen was not to be had, and the cotton stuffs of the country, or those which came from Peru, were substituted in lieu of it, and for brandy and Spanish wines, those of Cuyo were used. This stagnation of trade was at length relieved by the intervention of the neutral vessels of the Americans, which brought European goods to the colonies, and took away their surplus produce in return; and this contraband intercourse was found so indispensable to the trade of these countries, that it was either connived at or openly encouraged.

Interior Commerce.

A very extensive trade is carried on between the lower and upper provinces of this viceroyalty, and also with Peru and Chili. The herb of Paraguay, known by the name of Paraguay tea, and the cattle and mules of the provinces of Buenos Ayres and Tucuman, form the staples of this commerce. The herb of Paraguay is in such demand, that the crop on the ground is generally sold before it is gathered. The quantity exported to Peru is estimated at 2,500,000 lbs., and about 1,000,000 of lbs. are annually sent to Chili. The remainder is consumed in Paraguay, Tucuman, and the other provinces. There is a continual demand for mules in Peru and Potosi to carry on the work of the mines; and it is calculated that about 60,000 of these animals are

Buenos Ayres.

annually purchased for Peru and Potosi at the price of between three and four piastres a-head. These are driven into the interior by easy journeys to Salta, where they are taken great care of during the winter, and when in good condition, they are conducted to Potosi, where they sell for eight, nine, or ten piastres a-head; and such as are carried to Peru sell for higher prices, some for 40 and even 50 piastres. Peru and Potosi, and the mountainous districts where the mines are situated, are also supplied with large droves of cattle from the provinces of Buenos Ayres and Tucuman. These are either caught wild, or they are purchased from the immense pasture lands which extend over a great part of the province of Buenos Ayres, and are conveyed by easy journeys into the interior. A great trade is also carried on, more especially when the usual intercourse with Europe is interrupted by war, between Peru and Potosi, and the other provinces which were annexed to Buenos Ayres in the year 1778. These provinces being the principal mining countries, are on this account populous, while, owing to their elevated situation, the climate is bleak, and the soil barren. Supplies therefore, both of subsistence and of manufactures, must be drawn from more fertile regions; and the trade in question consists accordingly in exchanging the produce of the adjoining provinces for the precious metals which form the great staple of the mining districts. Peru, Chili, and the provinces to the east, receive from the mining countries supplies of gold and silver, in exchange for which they send maize, wheat-flour, cotton, oil, pimento, sugar, hides, wax, soap, tallow, &c. maize, woollen manufactures, and articles for the use of the mines, &c.

Estalla, the compiler of a voluminous collection, Population. which contains much valuable information on South America, called *Viagero Universal*, estimates the population of this viceroyalty at 1,000,000 of Spaniards and Creoles, besides Indians. He estimates the population of the city of Buenos Ayres at about 40,000, of whom one half are whites or Spaniards. Though reckoned the capital of the viceroyalty, it is not so populous as Potosi, which, according to Helms, contains a population of 100,000; an amount which so greatly exceeds all preceding accounts, as to render the accuracy of his information extremely doubtful. M. Humboldt, in his general table of the population of South America, which, however, he does not give as pretending to accuracy, estimates the Spanish and Creole population of this viceroyalty at 1,100,000; which exceeds Estalla's estimate by 100,000. Azara states the population of the province of Paraguay at 97,500, and that of the province of Buenos Ayres at 170,900.

In 1806, a British squadron, commanded by Sir British Expedition. Home Popham, appeared in the Rio de la Plata, from which a force was landed under the command of Major-General Beresford, for the reduction of Buenos Ayres. Some trifling resistance was offered by the Spaniards; but, in the end, General Beresford entered the town with little opposition. He appears to have been partly indebted for his success to the surprise into which the Spaniards were thrown by this unexpected invasion, for when they had suffi-

Buenos
Ayres.

ciently recovered from their panic, and had leisure to consider the inconsiderable numbers of their enemies, the British were assailed by such a superiority of force, that they were compelled to yield themselves prisoners of war on the 12th of August, having had possession of the place for about the space of six weeks. In the meantime, reinforcements arrived from the Cape, and Sir Home Popham, having made an unsuccessful attempt on Monte Video, took possession of the fort of Maldonado, at the mouth of the Plata. Additional reinforcements having arrived under the command of Sir Samuel Achmuty, the invaders succeeded at length in taking Monte Video by storm, and they only waited for farther succours to resume the attack of the capital.

The expected reinforcements at length arrived, in May 1807, under General Whitelock, to whom was committed the chief command of the expedition; and, on the 15th June, a farther reinforcement was received under General Crawford. With this force, amounting to 8000 men, it was resolved to attack Buenos Ayres by marching into the town. But no sooner had they entered the place, than they were assailed, from all quarters, with a commanding and superior fire of grape and musketry. The streets were intersected by deep ditches secured by cannon which poured upon the assailants an incessant and destructive fire; while, from the windows and tops of the houses, they were exposed to a galling fire of musketry, to hand-grenades, bricks, and stones. In this unequal contest, about a third of the British army was either killed, wounded, or captured, without any material advantage gained; and, next day, an armistice was concluded, which issued in a convention, by which it was agreed that the British should evacuate the Plata in two months; and that all prisoners taken on both sides should be restored.

Late Revo-
lution.

The project of the French Emperor to subdue Spain, for the purpose of establishing his brother Joseph on the throne, gave rise to a spirit of just indignation throughout the South American colonies; and when his successes seemed to pave the way for the subjection of the mother country, their first care was to take effectual measures for the security of their own independence. With this view, in the town of Buenos Ayres, the government of the viceroy was superseded by one of popular appointment; and though the leaders of the revolution still professed allegiance to Ferdinand, it was generally believed that they had secretly resolved to shake off the yoke of Spain. Different views, however, prevailed in other parts of the country. In Monte Video the Regency of Cadiz was recognised; and, in the interior, a counter-revolution was begun under the influence of Liniers and the adherents of the new government in Spain. To suppress this movement, a force was dispatched into the interior, at whose approach the chiefs of the counter-revolution fled, and being pursued and taken, they were barbarously murdered. The opposition to the revolution begun at Monte Video, was of a more formidable character. It was directed by Elio, an officer of marine, who arrived from Spain with the commission of viceroy, and who, not being able to prevail on the Junta of Buenos Ayres to recognise his

authority, proceeded to bombard the city and to destroy its commerce. On the other hand, the Junta sent their army against Monte Video, and compelled Elio to take refuge within the walls of the fortress. An armistice was afterwards concluded between the parties; but the subsequent transactions are yet involved in considerable obscurity. We propose to reserve the account of the revolution which has been begun in these colonies, for the Article SOUTH AMERICA; trusting that, before we shall have advanced so far in the course of our work, the cause of independence will have finally triumphed, and that we shall then be able to exhibit a distinct and satisfactory view of its progress, and of its probable results both to America and to Europe.

Azara, *Voyages en Amerique Meridionale, depuis 1781 jusqu'en 1801*. 4 vols. 8vo. 1809.—Humboldt, *Political Essay on the Kingdom of New Spain*, 4 vols. 8vo.—Wilcocke's *History of the Viceroyalty of Buenos Ayres*, 1806.—Helms's *Travels from Buenos Ayres, by Potosi, and Lima*.—Alcedo's *Geographical and Historical Dictionary of America and the West Indies*, translated by Thompson, 5 vols. 4to. 1810.—*Edinburgh Review*, Vol. XIX.

(a.)

BUKHARA, or BOKHARA, an extensive country in central Asia, situated to the north of the Oxus, which separates it from Khoarism and the kingdom of Caubul. Its principal cities are Bukhara and Samarcand. This ancient seat of the conquerors of Asia is now almost entirely unknown to Europeans. A few particulars, however, respecting its present state, were collected by Mr Elphinstone, during his residence in Caubul.

About the beginning of the sixteenth century, the descendants of Timur were driven from this territory by the Uzbeks, who, crossing the Jaxartes, swept all before them, till they were stopt by the central barrier of mountains. They thus established themselves, and have ever since remained the ruling people in Bukhara, Bulkh, Fergannah, and Khoarism. The Uzbeks belong to the great race of Turk or Toork, which, with the Moguls and Mandshoors, comprises all the people known in Europe under the general appellation of Tartar. The beauty of this race is celebrated by the Persian poets; though, for this admiration, it seems chiefly indebted to the contrast with the hideous deformity of the Mogul aspect. The Uzbeks are generally short and stout. Broad foreheads, high cheek-bones, thin beards, and small eyes, form the national features. Their complexion is clear and ruddy, and their hair generally black. Part of the nation live in houses and part in tents. Of the latter description, Bukhara contains a large proportion, as a great part of the soil is fit only for pasturage. This people have not the remotest idea of travelling on foot; every man keeps a horse or a camel; even the beggar must have an ass to ride upon. Horse-flesh is the favourite food; but can be obtained only in small quantities unless by the rich. Their drink consists chiefly of tea, and koumiss or kimmis, an intoxicating liquor drawn from mares' milk.

The Uzbeks, having embraced Mahometanism at a time when they probably had few other positive institutions, have adopted its precepts in their fullest

Buenos
Ayres
Bukhara

Bukhara

Bulkh.

extent. All the details of civil government, and the minutest observances of common life, are regulated by the precepts of the Koran. The King of Bukhara assumes the title of Commander of the Faithful; he spends a great part of the day in teaching the Mahomedan religion, and of the night in prayers and vigils. He reads prayers in his own mosque; and will sometimes perform the funeral service, even for people of low rank.

In Bukhara, and in all the Uzbek countries, the form of government is almost entirely despotic. The country is formed into divisions and subdivisions, which are governed by officers appointed solely by the sovereign. The villages alone have some share in their own administration; but this cannot form any material check on the royal authority. The Uzbeks are brave; they charge with shouts, drawn up in three lines which advance successively to the attack; so that, till the third has given way, they cannot be considered as finally defeated. They make admirable light cavalry from the rapidity of their movements, and from being patient of thirst, hunger, and fatigue, in an extraordinary degree. Their laws of war are entirely barbarous; infidel captives are sold as slaves; and this treatment being unlawful in regard to Mahomedan enemies, these suffer a more cruel fate, and are butchered without mercy. Yet, in the intercourse of private life, they display many laudable qualities. They are honest and sincere; quarrels are rare, and a murder scarcely ever heard of. Their hospitality is such, that Mr Elphinstone considers Bukhara as the country of Asia through which a traveller may pass with the greatest security.

The capital city, called also Bukhara, appears to be very considerable. Its population is said to be equal to that of Peshawar, and, consequently, exceeds a hundred thousand souls. This city contains numerous colleges, supported either by the king, or by private foundations. The sciences exclusively taught, indeed, are those of Mahomedan Theology and Jurisprudence; and, even in these, the fame of this city is inferior to that of Peshawar. Besides these institutions for education, Bukhara contains caravanseries, on a great scale, for the accommodation of trade; and, notwithstanding the rigid attachment of the people to the Mahomedan faith, strangers of every religion experience the most liberal toleration.

(B.)

BULKH, or **BALK**, a kingdom of central Asia, situated on the northern declivity of the immense chain of mountains, commonly called Hindoo Coosh, which separates it from Caubul. It forms thus the intermediate state between that kingdom and Bukhara. Some of its vallies, particularly along the Oxus, are lower, and suffer more from heat, than those of Caubul, on the southern side of the chain. This country was conquered, at the commencement of the sixteenth century, along with Bukhara, by the Uzbeks, who have ever since continued the ruling people. Bulkh was conquered by Nadir Shah; and, notwithstanding several revolutions, has since generally continued in a state of nominal subjection to Caubul. Killich Ally, however, an Uzbek prince, exercises at present an authority almost independent.

Bulkh

Bundel-
cund.

The king of Caubul does not even draw any tribute from Bulkh; he is content if it serve as a barrier against the northern Uzbek tribes.

The country is chiefly divided into three large provinces,—Bulkh Proper, Khoolloora, and Koon-dooz. Its government and manners being those common to the Uzbek tribes, have been described under the head of **BUKHARA**. Killich Ally maintains an army of 12,000 horse; after paying the expence of which, he has a clear revenue of a lack and a half of rupees (about L. 19,000). He is much beloved by his subjects, and affords such effectual protection to trade, that his praises are celebrated by all the caravans which traverse this part of Asia. He seats himself daily in his public apartment, on a carpet, without pillows or cushions. Those of his visitors whom he wishes to honour, are seated by him on the same carpet; while others must be contented with the bare floor. He superintends in person every department of the administration, executes justice with strictness, and is particularly attentive to the regulation of the bazar, or public market.

Bulkh is the ancient Bactria, which, for wealth and power, held a high pre-eminence among the kingdoms of central Asia. The capital was known under the name of Bactra, and seems to have been the grand emporium for the commerce of this part of the world. The Asiatics are impressed with the deepest veneration for its antiquity, and call it commonly "the mother of cities." Immense ruins still attest its ancient grandeur; but the modern Bulkh merely occupies a corner of the circuit enclosed by the ancient walls. The country round, however, is level and fertile, contains a great number of villages, and is watered by artificial canals. Tausk Koorghaun, the capital of Khoolloom, contains 8000 houses, and the capital of Koondooz still exceeds it in magnitude.

(B.)

BUNDELCOND, or **BANDELKHAND**, an extensive district of the province of Allahabad, in Hindostan, between the rivers Cane and Betwah, occupying a superficies of about 11,000 square miles. The south-west frontier lies in about 24° north latitude, and 80° 45' east longitude, and the territory extends about two degrees further north. In general, the face of this country is mountainous, high, and rocky; its vegetation is scanty, and the inhabitants do not bestow much care on the cultivation of it. The summits of many of the hills, however, are covered with low copses, amidst which there is but little grass interspersed. Other parts of the district exhibit a close jungle; and there are portions, consisting of fertile soil, which are brought under suitable culture.

The most valuable of all fossils, diamonds, have been long found here, particularly near the town of Mines. Purna or Pannah. The mines producing them are situated in a range of hills called Bund-Ahill by the natives, extending above twenty miles in length by between two and three in breadth, and are said to be partitioned into twenty-one divisions; but we do not know that the whole belong to Bundelcund. Of these, the mines of Maharajepoor, Rajepoor, Kimmerah, and Guddaseah, contain the finest diamonds; and one dug from the last has been reputed the largest in the world. It was kept in the fort of Cal-

Bundel-
cund.

inger, among other treasures of Rajah Himmat Bahadur. Several different rajahs are proprietors of the mines, each having the charge of his own, without any interest in the produce of the rest. A superintendent is appointed to inspect the produce, and every diamond when found is registered, valued, and, if the rajah does not chuse to keep it, is offered for sale. When sold, he receives two-thirds of the value. In the reign of the Emperor Ackbar, the mines of Pannah produced to the amount of L.100,000 annually, and were then a considerable source of revenue; but for many years they have not been nearly so profitable, and it appears that about the year 1750, the government did not derive more from them than equivalent to L.50,000 per annum. Their present value is not exactly known. According to tradition, the mines were discovered by a fakir or religious mendicant.

Aspect of
the country. The country, at a distance from the mountains, is agreeably diversified with clusters of eminences or small hills, separate from each other, exhibiting a picturesque appearance; and the inhabitants invariably build their villages at the bottom of a hill. They are seldom seen in any other situation, and it is chiefly around the villages that the small quantity of grain raised in the district is cultivated. But Bundelcund not being a fertile country in itself, grain is brought from the banks of the Jumna and the Ganges. Many other commodities are supplied from the Deccan, or middle region of the peninsula, and large herds of bullocks are seen continually passing to the hilly part of the territory. The forests abound with tigers, and the nil-gau or white-footed antelope, as also the wild boar, which are all hunted by the chief men of the country.

Inhabitants. The inhabitants, who are called Bondelas, are a brave and warlike people, entertaining high notions of independence, and impatient of constraint or indignity. They act under the full impulse of those violent passions which sway the inhabitants of the east, and lead to catastrophes of a nature unknown to Europeans. An instance occurred not long ago, when the fortress of Adyghur, besieged by the British troops, was evacuated by the garrison. The removal of the family of the refractory Zemindar who had occasioned hostilities having been directed, his father-in-law was desired to prepare the females of the family for it. Instead of doing so, however, he murdered the whole and their children eight in number, and then put an end to his own existence. But what was still more extraordinary, the perpetration of this horrible deed was apparently with the consent, and without any complaint of the sufferers. The Bondelas are either Bramins or Rajpoots. About Ditteah and Jhansi, they are a stout and handsome race of men, exhibiting an appearance of opulence and content. They commonly go armed with a bow and spear, both of which are of excellent quality; and they know very well how to use them. They testify no apprehension in engaging veteran troops. Owing to the intestine commotions which long pervaded this district, every man carried arms; and many, availing themselves of superior force, attacked and plundered travellers, or levied a contribution from them, on pretence of guarding the passes which they had necessarily to traverse among the hills.

Very little of their manners and customs is known. Women occasionally burn themselves along with the bodies of their deceased husbands, according to a remarkable religious principle diffused in the east, which now seems universally on the decline. The inhabitants dwell in towns and villages, of which the latter are much better than most others in India; and they have numerous strong forts, which they are accustomed to take and defend with determined vigour.

There are several considerable towns in the district, such as Pannah, Pirna or Purna, where the Rajah resides on account of its proximity to the diamond mines, Chatterpoor, Ditteah, Callinger, Jyghpoor, Jhansi. Chatterpoor, 30 miles distant from Pannah, and 698 from Calcutta, is extensive, well built, and the houses chiefly consist of stone. Formerly it was in a flourishing condition, a place of great and active commercial transactions, and a kind of depot for goods carried between the Deccan and Mirazpoor, which is also in the province of Allahabad, and one of the principal trading towns of Hindoostan. The goods were afterwards transported by numerous bullocks and camels to the places of their destination, and so much commerce was conducted here, that, when Chatterpoor preserved its greatest importance, the duties levied amounted to L.50,000 yearly. It was founded by one of the rajahs of Bundelcund, and occasionally his residence. Ditteah, or Duttosh, is a large town surrounded with a stone wall, and is provided with gates. It extends a mile and a half in length, by nearly as much in breadth, and is populous and well built, the houses being of stone, and covered with tiles. A spacious edifice, with seven cupolas, stands at the north-west extremity, which was the former residence of the Rajahs; but a palace has recently been built for them on an eminence without the town, close to which is a considerable lake. The district of Ditteah was tributary to the Mahrattas, and the Rajah could raise 2000 horse, and as many infantry, esteemed excellent troops. Some years ago, they testified how much they were to be dreaded in an engagement between the veteran forces under M. de Boyne, a famous French General in the Mahratta service, where all the skill and ability of the commander could scarcely preserve the latter from destruction. But among the most important places of Bundelcund is Callinger, the chief town of a subdivision of this district, which seems to have once been an independent government, and now includes ten pergunnahs or circles of villages. It has a fortification built on a lofty rock of great extent, and is deemed impregnable by the natives. The walls are said to be six or seven miles in circuit; 170 pieces of cannon are mounted on them, and a garrison of 5000 men is necessary for their defence. Nevertheless, its natural strength has enabled a smaller number to sustain long sieges; and the earlier invaders of Bundelcund have been compelled to retire after unsuccessful blockades protracted during several years. So lately as the year 1810, the British army, having attempted to take it by storm, was repulsed with great slaughter. However, the garrison of this fortress, probably dreading a repetition of the assault, ere-

Bundel-
cund.

coated the place during the night. No fortress can be more secure against the irregular approaches of an Indian army. Here the Rajah kept his military stores and treasure, and it was also the residence of the Europeans in his service. It is twenty or thirty miles from Pannah, and lies in 24° 58' north latitude. Jhansi is a considerable town, but smaller than Ditteah, commanded by a stone fort on a high hill, in 25° 31' north latitude, and thirty-two miles distant from Chatterpoor. There is a district dependent on the town, which, from having been seventy or eighty years in the uninterrupted possession of the Peshwa, or Chief of the Mahrattas, is in a more tranquil state, and better cultivated than most of the neighbouring territories which have undergone frequent changes. Hence it is frequented by caravans from various commercial towns of India; and its wealth is augmented by a trade in cloths, and the manufacture of carpets, bows, arrows, and spears, the principal arms of the Bondela tribes. In the year 1790, it afforded a revenue of about L. 50,000 annually. There is an ancient city called Ouncha, but now in decay, whose Rajah was formerly the head of all the tribes of Bundelcund, and from whom their chiefs received tokens of their investiture. A castle which stands here, or in the neighbourhood, resembles a gothic building, and is said to have been erected by a Rajah of old, who in one day gave orders for building fifty-two forts. This may account for the places of strength seen in Bundelcund, for which the particular character of its surface is extremely favourable.

Besides these, there are several towns, villages, and fortifications of consequence in this district, but recent events have rendered the preservation of the latter of less importance to their owners.

story.

Bundelcund from ancient times has been divided into many petty territories, whose chiefs have incessantly disturbed the peace of their subjects by predatory incursions on each other. The successful captures of strongholds in the mountains, was an encouragement to the subsistence of warfare; and in addition to the numerous ordinary sources of dispute, it is not unlikely that their joint interests in the diamond mines contributed to excite dissension. Though the predominance of power induced some one of the contending parties to claim the superiority, it was reluctantly acknowledged by the rest; whence, instead of a common bond of union to defend the country, it was weakened by the distractions of the whole. The Rajahs of Callinger are mentioned by Mahometan writers so early as the year 1008, but it does not appear to have been incorporated with Bundelcund for several centuries afterwards. Sometime in the sixteenth century, it is said that a Bondela, living in Benares, removed to a fort in the district of Ouncha, then governed by a Rajah whose confidence he speedily obtained. This Bondela had a daughter of exquisite beauty of whom the Rajah became enamoured, and demanded her in marriage. But her father, considering the proposal a grievous insult, from one whom certain circumstances now unknown prompted him to consider his inferior in rank, he, in concert with his daughter, plotted a diabolical revenge. Acquiescence was given on the

Bundel-
cund.

part of both, and the Rajah was invited by his bride to the house of the Bondela, where the ceremony was to be performed. Here a magnificent entertainment was prepared, of which he partook plentifully along with his attendants; but it was soon succeeded by excruciating tortures,—poison had been treacherously administered, and when the victims became incapable of defence, they were treacherously massacred. The Bondela then placed himself on the musnud of the Rajah, which he enjoyed peaceably until his death. He was succeeded by his son Ber Sing Deo, whose descendant is the Rajah of Ouncha, and he gained an accession of power by his services to the Soubahdar of Allahabad. But he is accused of being a great plunderer, and his history is stained by the assassination of the celebrated Abul Fazel, Prime Minister of Ackbar, which is said to have been committed by a banditti under his command. Nay, it is affirmed, that he acted in compliance with the wishes of Jehangeer, the emperor's son, who was jealous of Abul Fazel's influence over his father, and who, on his accession to the throne of Delhi, entrusted Ber Sing Deo with the government of all Bundelcund, then called Dungash. On descending to a later period, we find that this territory was invaded during the government of the Rajah Chatter-saul, about the middle of last century, by the chief of Furruckabad; and the Rajah, to aid him in repelling the enemy, applied for support to the Peshwa, Sewai Bajerow. Success having attended them, he adopted Sewai Bajerow as his son, and partitioned Bundelcund between him and his own sons. But allotting him a third of his dominions, the land revenue of which was estimated at about L. 1,300,000 Sterling, was under an express stipulation that his posterity should be protected by the Peshwa, in independent possession of the remainder. The rest of his male issue, said to exceed fifty, were in a state of dependence on their two brothers. In time this division opened the way to dissensions, a civil war ensued, and the consequent weakness of the chiefs afforded an opportunity for other invasions. Ali Bahauder, an illegitimate grandson of Bajerow, held a command in the army of Scindeah, the noted Mahratta chief, and in the same army was the Rajah Himmus Bahaudar, who not only commanded a great body of cavalry, but was the spiritual head and military leader of a numerous sect of devotees called Gossains. Both seem to have fallen under the displeasure of the Peshwa, and the latter, after retiring to his estate in 1786, soon united with the other in attempting the conquest of Bundelcund. The Rajah Himmus seems to have had it in contemplation to establish a sovereignty elsewhere; and about the year 1787, he was actively engaged in assisting the prince Mirza Jurvaim Bekhit, in raising an army, but whose death, which happened suddenly in 1788, probably allowed him more leisure to attend to the other object in view. He and his associates agreed that a large portion of the territory to be conquered should be assigned to himself, and its revenue applied to the support of certain troops which he engaged to maintain in the service of Ali Bahauder. The projected invasion took place in 1789; when Ali Bahauder conquered much of the district in

Bundelcund. the name of the Peshwa, of whom he rendered himself nearly independent; and in a short time the whole was subdued except some fortresses, which the Mahrattas have never been able to reduce.

Some years elapsed before the complete establishment of their authority; but an arrangement was made with the Peshwa, whereby he was acknowledged lord paramount of all the conquests effected in Bundelcund by Ali Bahauder, who engaged to obey him as his sovereign, and to pay him tribute. The latter contrived to evade both conditions, however; and, after being occupied fourteen years in endeavouring to subjugate the country, died in 1802, during the blockade of Callinger, which, during ten years, he had fruitlessly endeavoured to capture. Ali was succeeded by his eldest son, Shumshere Bahauder, then absent at Poonah; and Himmüt Bahauder, who, to retain his own influence, had for years been exciting disaffection among the different chiefs, now appointed a relation of Shumshere, the young rajah, regent of Bundelcund until his return.

A war next broke out between the British and the Mahrattas. Himmüt Bahauder endeavoured to accomplish the transference of this district to the former, while Shumshere was determined to oppose them vigorously. In September 1803, Colonel Powell crossed the river Jumna for the purpose of entering Bundelcund, and was joined by Himmüt with a body of 13,000 or 14,000 men. The united forces arriving on the banks of the river Cane, which, passing the fort of Callinger, falls into the Jumna, near the town of Oorah, found the army of Shumshere on the opposite side. It was numerous, occupied a great extent, and was strongly posted, but after a short cannonade on both sides it precipitately retreated.

At this time a proposal was made by the Mahrattas, and acceded to by the British, for the cession of a portion of the territory of Bundelcund in lieu of certain districts in the Deccan, which had been ceded to them by a former treaty. Forces were then stationed in Bundelcund for the protection of other parts, and successive engagements of a conciliatory nature were made with Shumshere, and all the rest of the chiefs, whereby the British authority was rendered paramount. Himmüt Bahauder had previously secured an advantageous arrangement for himself; and his death ensuing in the year 1804, Government provided for his family, and assumed possession of his territory. The troops who had been retained in his service, a kind of irregular force, now dispersed. Still, however, the tranquillity of the country was liable to be disturbed, and indeed the cession of some parts of it by the Mahrattas was only nominal, as they had never been able to occupy the strong holds themselves. Thus it was judged expedient by the British to bestow a considerable tract, in 1807, to a descendant of the Regent Chuttersaul, who had been long dispossessed amidst contending factions, on condition of guarding the passes and preserving his territory in peace. Other arrangements were made, conceding to the chief of Calpee, on the confines of Bundelcund, a portion of the interior, in lieu of the city and district of Calpee, and several villages on the Jumna. Meantime it be-

came necessary to besiege the fortress of Callinger; but notwithstanding the British forces had captured many strongholds of the Indians, previously deemed impregnable, they were unsuccessful in attempting to take it by assault, and, as already observed, gained possession by the garrison retiring in the night. Its reduction proved a great accession of power, and tended materially to tranquillize the district, which had previously been incorporated with the British empire in the East, and a civil establishment constituted for the regular management of its affairs.

The possession of a country such as Bundelcund, occupying 11,000 square miles, is of considerable consequence in several respects; and it has been suggested that the revenue derived from it might be materially augmented, by assuming the direction of the diamond mines of Pannah. Nevertheless the occupation of the whole does not seem to have been judged an important object, more especially, as, by the arrangement above alluded to, with the chief of Calpee, he was left in the enjoyment of a third part of them, to which he was originally entitled. (s.)

BURGER (GODFREY AUGUSTUS), a celebrated German Poet, born the 1st of January 1748, at Wolmerswende, a village in the principality of Halberstadt, where his father was Lutheran minister. In his childhood he discovered little inclination to study; the Bible and the Canticles alone had any attraction for him: these he knew by heart, and his first attempts in versification were imitations of the Psalms, which, notwithstanding their defects, gave proofs of feeling and a correct ear. It is to this first direction of his studies that we are to attribute the *Biblical* phrases, the allusions to Christianity, and the theological style, if we may be allowed the expression, which we find even in his amatory poetry. He was fond of solitude, and indulged in all the romantic sentiments which deserts and the gloom of forests inspire. From the school of Ascherleben, where his maternal grandfather resided, and which he quitted in consequence of a severe chastisement, which had been inflicted on him for composing an epigram, he was sent to the Institution at Halle; but, at neither of these places did he make any very sensible progress. He discovered a taste only for the lessons in prosody and versification which were given to the scholars of the Institution, in which his friend Gökingk was a class-fellow with him, who afterwards distinguished himself by his *Epistles and Songs*; and who has lamented the premature death of Bürger in an elegy to his memory. In 1764, Bürger, who was intended for the clerical office, began to attend the course of lectures given by the professors of the university. Klots, a learned classical scholar, admitted him of the number of young people whose talents he took a pleasure in cultivating; but this society appears not to have produced the same favourable effect on the moral character of Bürger as on his genius. His conduct prejudiced his grandfather Bauer against him, and it was with difficulty that he obtained from him some farther assistance, with permission, in the year 1768, to repair to Göttingen, to prosecute the study of the law, instead of that of theology. This change did not make him more regular in his studies; his manners

Bürger. became corrupted, and his grandfather withdrew his protection. Bürger contracted a number of debts, and his situation would have become altogether desperate, had it not been for the assistance of some friends. An association, memorable in the annals of German literature, had just been formed at Göttingen: it reckoned among its members Boje, Biester, Sprengel, Höltz, Miller, Vose, the two Counts Stolberg, C. F. Cramer, and Leisewitz. Bürger was admitted into it. All of these persons were versed in the Greek and Roman literature; and, at the same time, all of them idolised Shakespeare. The Germans are the only foreigners who seem to relish or understand the merits of this great genius in the same degree as his own countrymen profess to do; and they do not seem to like his genius the less on account of the irregularities objected to it by other nations. Bürger, in a great measure, owed his style to the enthusiasm which he showed in common with his literary friends for our celebrated tragic writer. The *Reliques of Ancient English Poetry*, published about this time by Dr Percy, gave an additional impulse to the direction which his mind had taken, and suggested to him some of the productions which his countrymen admire the most. Of all his friends, Boje was the one who exercised the greatest influence over him in the choice and management of his compositions. He taught him to make easy verses, by taking pains; and it is to his severe observations that the poetical stanza of Bürger owes a great part of that elegance and roundness which characterize it. To the same friend he was indebted, also, for some improvement in his circumstances, which, till the year 1772, had been very uncomfortable. On the recommendation of Boje, he was appointed to the Collectorship of Alvensleben, in the principality of Calenberg. The winter following, some fragments of a ghost story, which he heard a peasant girl singing by moon-light, caught his imagination, and his *Leonora* appeared, which soon became popular in all parts of Germany. Soon after the publication of this ballad, a circumstance occurred to give him still greater confidence in his talents: Going a journey to his native place, he one evening heard the schoolmaster of the village, in the room next to that in which he lay, reading to the assembled audience collected at the inn, the ballad of *Leonora*, which had just come out, and which was received with the liveliest marks of admiration. This proof of success flattered him more than all the compliments of his friends. About this time, he married a Hanoverian lady, named Leonhart; but this union proved only a source of bitterness to him, an unhappy attachment to her younger sister having sprung up in his heart. The loss of a sum of money, of which his grandfather had made him a present, was the first commencement of the embarrassment of his circumstances. The taking a large farm, which he did not know how to manage, increased it, and the dismissal from his place, which he was obliged to submit to in 1784, in consequence of suspicions (probably ill-founded) raised against the fidelity of his accounts, gave the finishing stroke to

VOL. II. PART II.

his misfortunes. He had, a little before, lost his wife; and it is but too certain that her death was hastened by the culpable passion which Bürger cherished in his heart. Left with two children, and reduced to the inconsiderable emoluments of *The Almanack of the Muses*, published at Göttingen, which he had edited since 1779, he removed to this city, with a view to give private lessons there, and in the hope of obtaining from the Hanoverian government a Professor's chair in the Belles-lettres. Five years after, this title was conferred on him, but without a salary; yet this was the only public recompence obtained during his whole life by a man who was one of the favourite authors of his nation; and who, while yet young, had enjoyed the highest reputation. Scarcely were the ashes of his wife cold, when he espoused her sister Molly, whose name his poems have made but too famous, and who had embittered the existence of his first wife; but he did not long enjoy the happiness after which he had sighed. She died in child-bed, in the beginning of 1786. From that moment, his own life only lingered on; and the fire of his genius seemed extinguished with the passion which had so long nourished it. He had scarcely strength enough, in the intervals of his dejection, to finish his *Song of Songs*, a sort of dithyrambic or nuptial hymn, intended to celebrate his second marriage, and which is a strange mixture of frantic passion, religious devotion, and the most bombastic expression. It was the last production of Bürger. Having studied the philosophy of Kant, he had an idea of deriving some advantage from it at Göttingen, where it had not yet been taught. He undertook to explain it in a course of lectures, which were attended by a great number of young people. The satisfaction which the university expressed to him for two Cantatas which he composed in 1787, at the period of the fifty years' jubilee of this illustrious institution, and his nomination to the situation of Professor Extraordinary, reanimated his spirits. Fortune appearing to smile on him once more, he formed the design of marrying again, in order to provide a mother for his children. During one of the moments when he was most occupied with this idea, he received a letter from Stuttgart, in which a young woman, whose style indicated a cultivated mind, and her sentiments an elevated and feeling heart, after describing to him, with enthusiasm, the impression which his poetry had made upon her, offered him her hand and heart. Bürger spoke of the thing, at first, only in jest, but the information which he received respecting the character, the fortune, and personal accomplishments of his correspondent, having excited his curiosity, he took a journey to Stuttgart, and brought back with him a wife who embittered and dishonoured the rest of his days. In less than three years, he saw himself under the necessity of obtaining a divorce from her, and the ruin of his health aggravated the absolute disorder of his finances. Confined to a small chamber, the favourite poet of Germany wasted the remainder of his strength in translations ordered by foreign booksellers; but sickness and grief soon deprived him even of this resource, and he must have died in

4 A

Bürger. the most frightful state of want, if the Government of Hanover had not extended some kindness to him. He died the 8th of June 1794, of a disorder of the bowels, of which he had never believed the danger.

Bürger is only remarkable as a lyric poet. He has tried all the different species of this class of the productions of genius; but he succeeded eminently only in the song and the ballad. We shall, perhaps, characterize his genius sufficiently by saying, that his imagination is more fresh than rich,—that he has more sensibility than elevation,—more naïveté and good nature than delicacy or taste. His style sparkles by its clearness, its energy, and from an elegance which is rather the result of labour than of natural grace; he possesses, in short, all the qualities which please the multitude. Allowing the title of poet only to those whose writings were calculated to become popular, he early habituated himself to reject whatever appeared to him not sufficiently intelligible and interesting to all classes of readers. Always clear and forcible, he is never either low or trivial; and if, at certain times, there appears a want of selection and care in the details, yet the sentiments are uniformly noble, and the moral intention of the majority of his pieces altogether irreproachable. Some breathe the loftiest piety and the purest love of virtue. Wieland said of him (see the German *Mercury*, 1778), that in composing his poem entitled *Männerkeuschheit* (on Chastity), Bürger had deserved better of the present and future generations, than if he had written the finest treatise of morality. This little piece has been inserted in most of the collections of hymns for the use of the Lutheran church.

There are three editions of Bürger's works. The two first appeared in his lifetime, in 1778 and 1789, in 8 vols. 8vo, and the third, after his death, was published by his friend Ch. Reinhard, in 4 vols., 1796. All three were printed at Göttingen. The last contains some posthumous pieces, and miscellanies in prose. We must confine ourselves to a short notice of those for which their merit or the singularity of the subject has procured the greatest degree of celebrity. I. A translation, or rather an imitation, of the *Vigil of Venus* (*Pervigilium Veneris*). It is a fine piece of poetic diction and rythmical harmony. II. *Leonora*, a romance, which belongs to the class which Bürger himself called the *epic lyric*. The story is borrowed from a popular tradition, of which the traces are to be found in the different countries of the north. *Leonora* was translated into Danish, in 1788,—six times into English, by Stanley, Pye, Spencer, Taylor, &c.—and from English into French, by De la Madelaine, in 1811. The translation by Mr Spencer is accompanied with engravings after designs by Lady Diana Beauclerc. Two German composers have set it to music. Bürger often appeared very ill-contented with the vast success of this production of his youth. He preferred a great number of his other poems, and was himself the first to blame the puerile trick of the play upon sounds which he has there indulged in. III. *The Minister's Daughter of Taubenhain*. It is the story of the seduction and tragi-

cal end of a young girl. There are in this, as in the other productions of the same author, some objectionable details, but the whole leaves a deep impression. IV. *The Inhuman Huntsman*. V. *The Song of the Brave*; in which the heroism of a peasant, who saves a family from the fury of the waves, is related with admirable feeling. VI. *The Song of Songs, conceived at the foot of the altar*. This is a hymn or ode in praise of his Molly. VII. *A Travesty of the Fable of Jupiter and Europa*. This is a piece of humour of the most clumsy kind, and in a taste the most wretched, yet it had a great run when it first appeared. VIII. *A translation, in iambic verse, of some books of the Iliad*. The choice of the measure is by no means happy. He was accordingly requested, ironically, to set about translating Anacreon into hexameters, when he had finished his version of Homer into German iambics. IX. An excellent *Translation of Shakespear's Macbeth*. X. *Pieces of Poetry and of Rhetorical Prose*. He had begun to write critical observations on his own works, with equal severity and sagacity. But he has only left some fragments of this work. XI. He was editor of the *Göttingen Almanack of the Muses*, from 1779 to 1794. Vetterlein, Pölitz, and Engel, have published a selection of the poetry of Bürger, with notes; and celebrated composers, such as Schulz and Reichardt, have set a great number of his songs to music. Bürger's third wife, whom German biography has thought worthy to have her name associated with his on account of her taste for literature, and particularly poetry, is author of several pieces in verse, inserted in the Collections. The one having for its title *The Raillery of a Mother*, is sufficient to prove her poetical talent.

See the account of Bürger in the sixth Volume of the *Biographie Universelle*. (z.)

BUSCHING (ANTONY FREDERICK). This very eminent Geographer was born at Stadthagen, a village of Westphalia, on the 27th September 1724. In his youth he laboured under peculiar disadvantages, arising from the disorderly life led by his father, and from the narrow means of education which his native town afforded. Fortunately, a clergyman of the name of Hauber, pleased with the promising talents of the young man, undertook to give him gratuitous instruction. He laid a solid foundation of learning, and also of a piety which, though fervent, was always accompanied with moderation and mildness. At the age of eighteen, young Busching was driven from his father's house, on account of the zeal with which he espoused the cause of his patron, on occasion of a controversy in which he was involved. Hauber, however, procured for him the means of continuing his studies at Halle. There, by his application to learning, and his irreproachable conduct, he acquired numerous friends. They procured him the appointment of tutor in the family of the Count de Lynars, who was then going as ambassador to Petersburgh. The observations made by Busching on this journey decided the pursuits of his future life. In travelling through Poland and Russia, he compared the actual features of those

ching. regions with the descriptions given of them. He thus became sensible of the miserably defective state of geographical science, and resolved to devote his life to its improvement. He withdrew as soon as possible from the Count's family, and went to reside at Copenhagen, devoting himself entirely to this new pursuit. In 1752, he presented the first specimen of his powers in a *Description of the Counties of Sleswig and Holstein*, a work which produced a favourable idea of his accuracy and ability. He soon after removed to Gottingen, and married Christiana Dilthey, a young lady of great accomplishments, authoress of a volume of poems, and to whom he had been engaged from the time of his departure to Russia. Here, on account of a work which appeared to dissent from some of the Lutheran tenets, he was excluded from the theological chair, for which he had become a candidate. The chagrin occasioned by this disappointment, induced him to accept an invitation to the German congregation at Petersburg. He was employed there, also, in organizing a school, which, under his auspices, soon became one of the most flourishing in the north. This school was superintended by Marshal Munich, who, at first, showed great favour to Busching; but being accustomed to entire obsequiousness from all connected with him, he did not accommodate himself to the hardy independence of the German sage. A collision arose, in consequence of which Busching announced to his congregation, that he was under the necessity of returning to Germany. The Empress expressed much dissatisfaction at the conduct of Munich, and made very high offers to Busching if he would consent to remain; but he deemed it unworthy of him, after having resisted the intreaties of his congregation, to yield to the favours of the Court. He returned to Germany without any fixed object or establishment in life, and went, at first, to reside at Altona. Next year, however, he was called to superintend an extensive establishment for education, which had been formed at Berlin, under the auspices of the great Frederick. His appointments here were liberal, and his exertions proved of signal benefit to the institution, of which he became the head. His writings and example gave a new impulse to education throughout Prussia. He spent a number of hours every day in the Institute,—superintended the progress of every pupil,—and inspected the minutest details connected with its prosperity. He gave also courses of Lectures on the History of the Arts and Sciences. This labour did not interrupt the composition of his numerous works. The Queen loved his society, and, at first, often invited him to dine with her; but, finding that such engagements occupied too much of his time, he intreated her Majesty to allow him to devote himself, as much as possible, to his numerous labours. Though seized with dropsy, which occasioned a series of the most cruel sufferings, he did not remit his academical labours, till the disease, coming to a crisis, terminated his life on the 28th May 1793, in the 69th year of his age. His wife had died in 1777, and he had contracted a second marriage with Mad^{le}. Reinbeck, the daugh-

ter of a clergyman at Berlin. By the first marriage, he had two children, who survived him; by the second, he had six, who, except one, all died in infancy. Busching
Bateshire.

Few authors, even in Germany, have produced a greater number of works than Busching. The entire number, as enumerated by Meusel, in his *Lexicon of German Authors*, amounts to more than a hundred. They may all be classed under the following heads: 1. Geography and History. 2. Education. 3. Religion. 4. Biography. The first class comprehends those upon which his fame chiefly rests. He possessed not, indeed, the geographical genius, if we may so speak, of D'Anville; his skill in the construction of maps, his quick eye, or his sagacity in eliciting the truth from hints and imperfect notices. He may be regarded, however, as the creator of modern *Statistics*,—that science which exhibits the present state of every kingdom, its civil and political constitution, its wealth, the productions of nature, the exchanges of commerce, and the establishments for public instruction: all these particulars are detailed in his works in the fullest manner, and from the most careful investigation of original materials. His works, devoid of the ornaments of style, and composed of minute details, are rather useful to consult, than profitable to read; but this is a fault to which most writers of his country are liable. His grand work is the *Neue Erdbeschreibung, New Geographical Description of the Globe*. The four first parts, which comprehend Europe, were published in four successive volumes, from 1754 to 1761, and have been translated into all the European languages. They appeared in English, with a preface by Murdoch, in six volumes 4to, London, 1762. He published also in 1768 the fifth part, being the first volume upon Asia, containing *Asiatic Turkey and Arabia*. It displays an immense extent of research, and is generally considered as his masterpiece; but has not been translated either into French or English.

Besides this great geographical work, Busching was the editor of a valuable collection, entitled *Magazine for the History and Geography of modern times*, 22 vols. 4to. 1767-88; also of a *Journal appropriated to the Notice of Maps*, Berlin, 1773-87.

The elementary works on education, published by Busching, are very numerous, and have long held a distinguished place, even in a country so eminent as Germany, in this branch of literature. If, in some departments, better works have now been produced, it is by labouring on the foundation of Busching. His theological writings are not very highly esteemed. In biography, he wrote a number of articles for the *Historical Magazine*; also *A Collection of Biography*, in six volumes, 1783-9, including a very elaborate life of the great Frederick. (B.)

BUTESHIRE, a county on the west coast of Scotland, in the Firth of Clyde, comprehends the Islands of Bute, Arran, the Cumbraes, Inchmarnoch, and a few smaller islets.

BUTE, which gives name to the county, is separated by a narrow channel from the district of Cow- and Extent.

Buteshire. al in Argyleshire. It is about 15 miles long, and 3½ miles broad, but so much indented by the sea that the heads of some of the bays on the opposite sides of the island are not more than a mile distant; and it contains nearly 30,000 acres, of which more than a half is susceptible of cultivation. The country is generally low, few of its hills rising more than 200 feet above the sea. The climate, though very moist, is so mild as to be compared with that of Devonshire; and the soil is for the most part dry, and naturally fertile.

Agriculture. A former Marquis of Bute, to whom seven-eighths of the island belonged, began, so early as 1758, to promote the improvement of the island and its inhabitants; but his plans, though apparently well calculated for this purpose, do not seem to have effected any favourable alteration, probably owing to his absence from the country, and to his time having been engrossed by public affairs. The present Marquis, however, has within these few years displayed a very laudable attention to the same object. An eminent agriculturalist has been employed to survey the island, and to point out the defects in its husbandry in a small treatise which is distributed gratis; and young men have been sent to the border counties, as apprentices to some of the best farmers in that district, to whom the noble proprietor means to give a preference as tenants. All the crops common in the lowlands of Scotland are cultivated in Bute; and, though modern husbandry be yet in its infancy, its progress in the southern parts of the island, where the land is enclosed with white-thorn hedges, is by no means inconsiderable.

Minerals. Slate and limestone are found in various quarters of the island, from which also there is ready access to the noted limestone quarries in the north of Ireland. Coal has not yet been discovered. Beds of sea-shells abound on the western side, and vast quantities of sea-weed are thrown upon its shores.

Fisheries. The herring-fishery was formerly prosecuted by the inhabitants of Bute with great success; but of late it has declined, and at present does not much interfere with agriculture, as it is chiefly confined to the town of Rothsay. White fish and shell fish, though abounding on the coast, have been hitherto much neglected. In the town of Rothsay, the principal town of Buteshire, from which the heir apparent to the British throne takes the title of a Scottish duke, there has been a cotton manufactory for several years. The vessels belonging to this port in 1812 carried 5195 tons; and it has a regular communication by packets with Greenock, and by a daily mail-boat with Largs in Ayrshire.

Rains. In the ruins of the castle of Rothsay, the principal residence of the Stuarts, ancestors of the present family of Bute, till it was burned in 1685, are still pointed out the bedchambers and banquetting rooms of Robert II. and III. the last Scottish monarchs who inhabited this venerable pile. Mount Stuart, the seat of the Marquis of Bute, from which he takes his second title, is an elegant house, with fine woods and pleasure-grounds, situated about two hundred yards from the eastern shore, and commanding a delightful view of the navigation of the Firth of Clyde, and of the opposite shore.

ARRAN, lying about twelve miles south from Buteshire Bute, is something more than twenty miles long and from eight to eleven miles broad; and contains, by Arran, the latest estimation, more than 100,000 acres, of which only a seventh part may be fit for cultivation. It is an extremely rugged and mountainous country, particularly the northern part, in which the valleys are deep and romantic. Goatfield, a mountain Surface, nearly in the centre of the island, is about 3000 feet high, and a few others approach to the same elevation. The climate, in winter, is exceedingly severe; and, like that of all the other western isles, moist during the other seasons. With the exception of a few farms, the whole island belongs to the Duke of Hamilton, who has very lately begun to take an interest in its improvement, and expended a considerable sum in making roads, bridges, and small harbours. Game is in great abundance, particularly grouse, which are surprisingly numerous on the mountains. Limestone, marl, and slate, are found in different parts, and there are indications of coal also. The herring fishery is prosecuted to great advantage. Arran has two remarkably fine harbours, Harbours, Lamash on the east side, and Loch Ranza on the north. Its agriculture does not seem to have improved much since the time when Pennant visited it. The arable land of a farm is still occupied in intermixed ridges, or what in Scotland is called *run-rig*, by a society of tenants, who interchange their possessions every year, or every two years at the longest; and, adjoining to this portion, a common pasture is allotted for their cows, under the charge of a herd. The highest grounds are held in common by the tenantry at large; and, as soon as the crops are removed, the live-stock pasture indiscriminately over the whole island. See the Article **ARRAN** in the *Encyclopædia*.

The **CUMBRACKS** are two small islands on the coast of Ayrshire, but do not, as has been inadvertently stated in the article **AYRSHIRE**, make a part of that county. The largest, which belongs to the Marquis of Bute and the Earl of Glasgow, contains about four square miles, of which a half is cultivated; and the smallest, the property of the Earl of Eglington, only one mile, on which there is a light-house, with four or five families, and a great number of rabbits.

INCHMARNOCH, a beautiful islet, lies to the south-west of Bute, and takes its name from a chapel on it, dedicated to St Marnoch, of which the ruins are still visible. Its surface is less than a square mile, and about a third of it is cultivated.

PLADDA, another islet belonging to Buteshire, is about a mile to the east of Bute. A light-house was erected on it a few years ago. The only other islet worthy of notice in this county is Lamash, which covers the harbour of that name in Arran.

The county of Bute sends a Member to Parliament alternately with Caithness; and Rothsay, the only royal burgh it contains, unites with Ayr, Irvine, Campbelton, and Inverary, in electing a Member for the boroughs. The valued rental, according to the books of the collector of the land-tax, is in Scots money L. 15,042, 13s. 10d., divided among only

shire eleven estates; and that of the lands held under entail is a third of the whole. The real rent in 1811 was, for the lands L. 18,591, 9s. 2d., and for the

houses L. 2810, 1s. 7d. Sterling. The following tables exhibit an abstract of the returns made under the Population Acts of 1800 and 1811.

Bateshire
Cabanis.

1800.

HOUSES.			PERSONS.		OCCUPATIONS.			Total of Persons.
Inhabited.	By how many Families occupied.	Uninhabited.	Males.	Females.	Persons chiefly employed in Agriculture.	Persons chiefly employed in Trade, Manufactures, or Handicraft.	All other Persons not comprised in the two preceding classes.	
1911	2501	17	5552	6239	3161	4821	3809	11,791

1811.

HOUSES.			PERSONS.		OCCUPATIONS.			Total of Persons.
Inhabited.	By how many Families occupied.	Uninhabited.	Males.	Females.	Families chiefly employed in Agriculture.	Families chiefly employed in Trade, Manufactures, or Handicraft.	All other Families not comprised in the two preceding classes.	
2047	2618	38	5545	6488	1214	530	874	12,033

(A.)

C A B

CABANIS (PETER JOHN GEORGE), a distinguished Writer and Physician at Paris, was born at Conac in 1757. His father, John Baptiste Cabanis, was a lawyer of eminence, and chief Magistrate of a district in the lower Limousin; highly respected for his extensive knowledge and inflexible integrity, and entitled to the gratitude of his country for the many improvements he has introduced in agriculture and farming. He brought the culture of the vine to great perfection in his province, and introduced a mixed breed of sheep, by crossing the Spanish with those of Limousin and Berri. France is more particularly indebted to him, however, for the successful methods he discovered of grafting fruit trees, and also for contributing to render more general the use of the potatoe in the southern provinces. He was exceedingly anxious that his son, the subject of the present article, and who had given early indications of talent, should have the advantage of a learned education; and, accordingly, placed him, when only seven years old, under the tuition of a neighbouring priest. It was remarked, that, even at this early age, he had acquired habits of steadiness and perseverance, from which, under proper direction, the best results might be expected. At the age of ten, he entered the college of Brive, where the severity of discipline to which he was subjected, had an injurious effect upon his temper, and fostered that habitual impatience of restraint which formed part of

his character, and which afterwards so frequently operated to interrupt his progress. When raised to the second class, he was fortunate in meeting with a master whose kind treatment soon softened a disposition, which harshness only had rendered stubborn and intractable. He was not only reconciled to study, but applied to it with the utmost diligence, and became passionately fond of the great models of poetry and eloquence that were put into his hands. At a later period, being again exposed to the rigorous control of one of the heads of the college, his spirit was again roused; he came to the determination of provoking the anger of his master, and even suffered himself to be accused of a fault of which he was innocent, in the hope that he might get expelled. Persisting in this extraordinary mode of conduct, he soon accomplished his object, and was sent back to his father. But far from enjoying any relaxation under the paternal roof, he now found himself under a subjection still more rigorous and insupportable than that from which he had managed to escape. Indignant at the yoke imposed upon him, he relapsed into his habits of obstinacy, and would do nothing. After a year had thus passed in sullessness, his father became sensible that other measures than those of severity must be tried, and adopted the bold expedient of taking him to Paris, and leaving him there, at the age of fourteen, without any restraint on his actions, or even commissioning

Cabanis any one to superintend his conduct. The experiment was hazardous in the extreme; but it was attended with complete success. Young Cabanis no sooner felt himself at full liberty to do as he pleased, than his love of literature revived, and he engaged with ardour in the pursuit. He had formerly paid no attention to the lectures of his professors; but he now, of his own accord, resumed those branches of his education in which he had remained deficient, and prosecuted them with the same perseverance which throughout marked his character. He devoted himself entirely to the cultivation of his mind, and associated only with a few chosen companions of his own age, who had a congenial taste for literature, and an equal desire of improvement.

Thus constantly occupied, two years passed away with a rapidity which astonished him, when he received a letter from his father, offering him the place of secretary to a Polish nobleman of high rank. He had now to choose between accepting a situation, which, although it would totally interrupt his present pursuits, might give him the power of resuming them at some future period, or returning to his family, where he felt that all his exertions must be paralysed, and his hopes blighted by neglect. He embraced, therefore, without hesitation, the offer made to him, and, though only sixteen, committed himself into the hands of strangers, in a distant country, which was represented to him as in a state of barbarism. This was in 1773, the year during which that Diet was sitting, which was to deliberate upon giving its sanction to the first partition of Poland. The corrupt intrigues and compulsory measures which were practised on that occasion, gave him an insight into the affairs of the world peculiarly revolting to a youthful and generous mind, and inspired him with a contempt for mankind, and a degree of misanthropic gloom, which are generally the fruits of a later experience of human depravity. He returned to Paris two years after, when Turgot, the friend of his father, was Minister of Finance. On being presented to him, he was received with kindness, and would soon have been placed in a situation perfectly conformable to his tastes and wishes, had not a court intrigue produced the sudden downfall of the minister.

Thus, the only fruits which he had gathered from his travels, were the knowledge of the German language, and a premature acquaintance with the world. He now felt the necessity of making up for the time he had lost, and again applied to his studies with his former ardour. His father feeling it incumbent upon him to second his efforts, secured to him the means of subsistence for two or three years longer, which was all that Cabanis desired. He had contracted a friendship with the poet Roucher, who possessed some celebrity. This connection rekindled his taste for poetry; and the French Academy, having proposed, as a prize subject, the translation of a passage in the *Iliad*, he not only ventured to appear as competitor, but set about translating the entire poem. The two specimens which he sent to the Academy, did not obtain any public notice; but they were judged of favourably by several persons of taste; and some other frag-

ments that were published among the notes to the poem *Des Mois*, met with general approbation. He received the approbation of those critics who were the dispensers of literary fame in Paris, and was introduced at once into a large circle of acquaintance, where he was everywhere greeted with acclamation. He was soon, however, sensible of the emptiness of these applauses; and dissatisfied with successes that offered no prospect of solid advantage, he sunk into a state of melancholy, which, together with his excessive application to study, began visibly to prey upon his constitution. His father now urged him to choose a useful profession, and he at length decided for that of medicine, which, embracing such various objects of study, presented an ample field for the exertions of his active mind, while it necessitated that degree of bodily exercise, which had become so necessary for the preservation of his health. Dubreuil, whose counsels had had much influence with him in forming this determination, offered to be his guide in the new and arduous career which he was commencing. Cabanis continued for six years the pupil of this able master, following his steps both in his hospital and private practice, and conducting his studies conformably to his instructions. In 1789 he published *Observations sur les Hôpitaux*; a work which procured him the appointment of Administrator of Hospitals at Paris.

His state of health, in the midst of his laborious professional exertions, requiring occasional relaxation in the country, he fixed upon Auteuil, in the immediate vicinity of Paris, as his place of residence. It was there that he became acquainted with the widow of Helvetius, and ever after cherished for that excellent woman the affection of a son, as she, on her part, fulfilled towards him the duties of the kindest mother. He spent all his leisure hours in her society; and profited by the opportunity her house afforded him of cultivating the acquaintance of the most distinguished literary men of that period. He continued his intercourse with Turgot, was on terms of intimacy with Condillac, Thomas, and D'Alembert; and acquired the friendship of Holbach, Franklin, and Jefferson. During the last visit which Voltaire made to Paris, Cabanis was presented to him by Turgot, and read to him part of his translation of the *Iliad*, which that acute critic, though old, infirm, and fatigued with his journey, listened to with great interest, and bestowed much commendation on the talents of the author. Cabanis had now, however, long ceased to occupy himself with that work, and fully engaged with the studies and duties of his profession, had renounced the cultivation of letters. He even bade a formal adieu to poetry in his *Serment d'un Médecin*, which appeared in 1783, and is a free imitation of the Greek of Hippocrates, but is more remarkable as exhibiting the author in the light of a zealous friend to liberty. Political interests were now, indeed, beginning to engross the general attention, and the muses were deserted amidst the contentions of parties, the din of arms, and the various anxieties and passions, which were called into play during this eventful period. Cabanis espoused with enthusiasm the cause of the revolution, to which he was attached from principle,

and of which the opening prospects were so congenial to his active and ardent mind. But however he may have shared in the intoxication which seized its early partizans, it is certain that he had no participation in the criminal excesses which followed, and which have left so indelible a stain upon the history of those times.

During the two last years of Mirabeau's life, he was intimately connected with that extraordinary man, who had the singular art of pressing into his service the pens of all his literary friends, whom he engaged to furnish him with their ideas, in writing, on the political topics of the day, that he might afterwards combine them as he chose, and adopt them as his own. Cabanis united himself with this disinterested association of labourers, and contributed the *Travail sur l'éducation publique*,—a tract which was found among the papers of Mirabeau at his death, and was edited by the real author soon after, in 1791. During the illness which terminated his life, Mirabeau confided himself entirely to the professional skill of Cabanis; and though repeatedly and strongly urged, as his danger increased, to have farther medical assistance, constantly refused to have recourse to any other advice. Of the progress of the malady, and the circumstances attending the death of Mirabeau, Cabanis has drawn up a very detailed narrative, which, whatever proof it may afford of the warmth of his friendship for his patient, is not calculated to impress us with any high idea of his skill in the treatment of an acute inflammatory disease.

Condorcet was another distinguished character with whom Cabanis was on terms of intimacy. The calamitous events of the Revolution, and the relentless persecution which the former was suffering from the party which had gained the ascendancy, tended only to unite them still more closely in the ties of friendship; and Cabanis exerted every means in his power to avert his impending fate. But all his efforts were unavailing; and he had only the melancholy consolation of preserving the last writings of his unfortunate friend, and of collecting his dying wishes relative to his wife and children. Soon after this event he married Charlotte Grouchy, sister to Madame Condorcet, and to General Grouchy; a union which was a great source of happiness to him during the remainder of his life.

After the subversion of the government of the terrorists, on the establishment of central schools, Cabanis was named Professor of *Hygiène*, in the medical schools of the metropolis. He was chosen member of the National Institute the next year, and on the following, was appointed Clinical Professor. He was afterwards member of the Council of Five Hundred, and then of the Conservative Senate. The dissolution of the Directory was the result of a motion which he made to that effect. But his political career was not of long continuance. He was profoundly affected at the turn which the affairs of his country were taking, so unfavourable to the cause of liberty, and so dispiriting to the friends of humanity; and the latter years of his life were, in consequence, deeply tinctured with melancholy. A foe to tyranny, under every shape, he was decidedly hostile to

the policy of Buonaparte, and had constantly rejected all his solicitations to accept of a place under his government.

For some years before his death, his health became gradually more impaired, in consequence of the exertions and anxieties he had undergone; and, in the spring of 1807, he had a slight apoplectic attack, from which he soon recovered. He took, however, the warning that was thus given him, and retired from the laborious duties of his profession, spending the greatest part of his time at the chateau of his father-in-law, at Meulan, about thirty miles from Paris. Here he again solaced himself with reading his favourite poets, and even had it in contemplation to resume his translation of the *Iliad*, which had been the first effort of his youthful muse. The rest of his time was devoted to acts of kindness and beneficence, especially towards the poor, who flocked from all parts to consult him on their complaints. Increasing infirmity now made him sensible that his life was drawing near to a close, and he was fond of conversing on the subject of his approaching end,—an event which he always contemplated with perfect serenity of mind. A more complete attack of his disorder, at length, carried him off, on the 5th of May 1808, when he had attained his fifty-second year. He left a widow and one daughter to lament the loss of one, who united to the ornaments of a highly cultivated mind, the greatest sensibility and benevolence of heart.

Besides the tracts already mentioned, he was author of several other works. The only one among them which is purely of a literary nature, is the *Mélanges de Littérature Allemande, ou Choix de traductions de l'Allemand, &c.* Paris, 8vo, 1797. It is dedicated to Madame Helvetius, and consists of translations of different works of Meisner,—of a drama of Goëthe's entitled *Stella*,—of Gray's *Elegy on a Country Church-Yard*,—and of the *Idyl of Bion on the Death of Adonis*. His work, *Du degré de certitude de la Médecine*, appeared in the same year, and a second edition was published in 1803, containing a republication of his *Observations sur les Hôpitaux*, and his *Journal de la Maladie et de la Mort de Mirabeau l'aîné*; together with a short tract on the punishment of the guillotine, in which he combats the opinion of Soemmerring, Celsuer, and Sue, that sensibility remains for some time after decapitation. This tract had already appeared in the *Magazin Encyclopédique*, and in the first volume of the *Mémoires de la Société Médicale d'Emulation*. This new edition also contains his *Rapport fait au Conseil des Cing-cents sur l'Organisation des écoles de Médecine*; and a long dissertation entitled, *Quelques principes et quelques vues sur les secours publics*. In 1799, he published *Quelques Considérations sur l'Organisation sociale en général, et particulièrement sur la nouvelle Constitution*, 12mo. His principal work, however, is that entitled, *Des Rapports du Physique et du Moral de l'Homme*, 1803, in two volumes 8vo; consisting of twelve essays, the first six of which had been presented to the National Institute, and were inserted in the two first volumes of their *Memoirs*, in the Class of Moral and Political Sciences. This work was reprinted in the following year, with the

anis.

Cabanis.

Cabinet
|
Caermar-
thenshire.

addition of a copious analytical table of its contents by M. Destutt-Tracy, and alphabetical indexes by M. Sue. His *Coup d'œil sur les Révolutions et les réformes de la Médecine*, came out in 1808. Of this work we possess an excellent English translation, with notes, by Dr Henderson. His only practical work on medicine is the *Observations sur les Affections Catarrhales en général, et particulièrement sur celles connues sous le nom de rhumes de cerveau, et rhumes de poitrine*, 8vo, 1807. He wrote many interesting articles in the *Magasin Encyclopédique*. Several of his speeches to the Legislative Assembly are given at full length in the columns of the *Moniteur*.

(w.)

CABINET-MAKING, see JOINERY.

Extent and
Surface.

CAERMARTHENSHIRE, a county in South Wales, containing 926 square miles, or about 590,640 acres. The northern and eastern parts are mountainous. Near the sea the land is flat, but the general surface of the county is hilly. It is intersected in almost every direction by valleys, from the sides of which the hills rise abruptly. These valleys are, for the most part, very narrow. The most celebrated for fertility and picturesque beauty, as well as the most extensive, is the vale of Towy, which stretches thirty miles up the county, with a breadth of only two miles. From the celebrated Grongar Hill, and the ruins of the Castle of Dynevor, the picturesque beauty of this vale are seen to the greatest advantage.

Rivers.

The principal rivers in Caermarthenshire are the Towy, the Teivy or Tair, the Cothy, the Dulas, and the Gwilly. The Towy rises in Cardiganshire. It enters Caermarthenshire, at its north-eastern corner, crossing towards the south-west, and, passing Caermarthen, it empties itself into the large bay, between the counties of Glamorgan and Pembroke, called Caermarthen Bay. Many rivulets join the Towy in its course, among which is the Cothy. This stream rises on the north side of the county, and, running mostly in a southern direction, unites with the Towy about six miles above Caermarthen. The Teivy rises in Cardiganshire, between which county and Caermarthenshire it afterwards forms the boundary; soon after receiving the Keach, it enters the county of Pembroke.

Ports.

The principal ports in this county are Llanelly, Kidwelly, Caermarthen, and Llaugharne. Llanelly has a good port for vessels of ten feet draught, formed by an inlet of the sea called Burry River, which divides this county and Glamorganshire. Llanelly is the port of entry of Kidwelly and Caermarthen: its exports are coal and tinned iron plates. Kidwelly is situated on two small streams, called Givandraeth, which form a little haven, but mostly choked with sand. From this town a canal has been cut, at the expence of a private gentleman, between three and four miles long, to his coal-mines and lime-quarries; and, by means of this canal, Kidwelly has been enabled to export a considerable quantity of coals. Vessels of 250 tons burden ascend to the bridge of the town of Caermarthen on the Towy, but the entrance of the river is rather difficult, in consequence of a bar across it. The principal exports of Caermarthen are tin plates and cast-iron. Llaugharne, on a creek, is chiefly remarkable for a considerable

flat tract in the vicinity, embanked from the sea, and of singular fertility.

The climate of this county is soft and mild, but moist; the soil of the lower districts is fertile, being for the most part either a rich clay, or a sharp or deep loam. Little wheat is grown; and, except on the lighter soils, barley is not a common crop; but oats are extensively cultivated, and in respect both of produce and quality, are a very profitable crop. Great quantities are exported, chiefly to Bristol. The pasture land, especially where the soil is suitable, support a heavy stock; they are applied either to the dairy, or to the breeding of black-cattle and horses. The latter are reared in great numbers on the hills, and constitute the principal article of trade at the fairs of this and the adjacent counties. Much butter is exported. It is computed that 114,000 acres are in tillage; and about double that number in pasture; the rest is unfit for cultivation, though by no means unprofitable. According to the original agricultural report of this county, there are only about 170,000 acres of wastes and commons. This county was formerly extremely well wooded; but, of late years, great waste has been made of the timber. Its rivers and sea-coast abound in fish, especially salmon of excellent quality, and a species of trout, called Suen, in high request with epicures.

Caermarthenshire is rich in mineral productions. Coals and lead are the most abundant and profitable. The greatest lead-mines are not far from Llandowry. Limestone also abounds, and there are considerable quantities of iron ore. The sands in the vicinity of Llaugharne, according to Mr Donovan, abound in shells of great rarity and beauty. On the road from Caermarthen to Llandillo Vawr, a medicinal spring has lately been discovered, containing carbonic acid gas; carbonate of iron, and lime; muriate of soda and lime; and sulphate of lime. At Kastell-Karreg there is a fountain, which ebbs and flows twice in twenty-four hours. There are several remains of antiquity, chiefly Roman, to be seen in Caermarthenshire.

The inhabitants, who are not engaged in agriculture, are principally employed in working the mines, or in manufacturing the produce of these mines, or in making woollen stockings. The most extensive manufactures of tinned iron-plates are carried on at Kidwelly; here are also other manufactures of iron, for which there are large and excellent furnaces, forges, flatting-mills, &c. Tinned-plates and cast-iron are also manufactured at Caermarthen, and the works in both branches are extensive. In the neighbourhood of Llandowry, the woollen-stocking manufactory principally prevails.

The money raised for the maintenance of the poor in 1803 was L.17,046, at the rate of 12s. 9d. in the pound. In the year ending the 25th of March 1815, there was paid, in parochial rates, the sum of L.30,354, 6s. 9d. from 83 parishes alone, the remaining 43 not having made any return. By the population returns, in the year 1800, there were 13,449 inhabited houses, 67,317 inhabitants, 31,439 males, and 35,878 females; of this number 32,802 were returned as employed in agriculture, and 4345 as

Caernarvonshire employed in trade. The following are the results of the last population-return, in 1811 :

Inhabited houses,	-	-	14,856
Families inhabiting them,	-	-	16,083
Houses building,	-	-	113
uninhabited,	-	-	333
Families employed in agriculture,	-	-	9878
in trade and manufactures,	-	-	3256
not included in these heads,	-	-	949
Males,	-	36,080	
Females,	-	41,137	
<hr/>			
Total population in 1811,		77,217	
in 1800,		67,317	

Increase, 9,900

See *Agricultural Report of South Wales*.—Malkin's *Scenery of South Wales*.—Evans's *Tour*.—Denovan's *Excursions*. (c.)

CAERNARVONSHIRE, a county in North Wales, is divided by the Conway from Denbighshire; from part of Merionethshire by a rivulet; from Anglesea by the straits of Menai: the residue is bounded by the sea. In figure it is very irregular, a great peninsulated point running out from it to the south-west. From the extremity of this point, the length is 45 miles; the breadth varies extremely; its circumference is about 150 miles. It contains, from a late survey, 300,000 acres of land, of which, by one account, about 200,000, and, by another account, only 160,000 are in a state of cultivation.

This county is the most mountainous in Wales. Its central part is entirely occupied by Snowdon, and its subordinate mountains, extending from near Conway in the north-east to the shore that bounds the Perthorian road, including the Rhifel ridges. The Snowdon mountains are connected with another chain of hills, which approach the sea at Aberdaron. Among these are very deep passes, forming narrow valleys, through which numerous streams, issuing from various lakes, rush in some places with great violence. The highest region of the mountainous district is covered with snow, during the greatest part of the year; the middle region affords fuel and pasturage, though the woods which once clothed it are nearly exhausted. The bases of the mountains and the valleys are in general temperate and fertile. The vale of Conway is the most extensive in the county; it is a long and narrow tract, equally romantic and beautiful, through which the river of the same name runs. At first it is very narrow, but it gradually widens to the breadth of a mile. Its extent is about twenty miles, terminating at the town of Conway. It affords rich pasturage, especially near Llanwost, where it is formed into the finest meadows, corn-fields, and groves,—and exhibits a striking and pleasing contrast to the bleak regions of Snowdon frowning above it.

The general escarpment of the mountains, which rise from the sea towards the centre of this county, fronts the sea. But the particular escarpment of the detached groups, depends upon the course of the

streams. The mountain of Snowdon is composed of various cliffs of different heights; the altitude of the highest point of the mountain is about 3600 feet from the high-water mark on Caernarvon quay. Snow lies all the year in the hollows near the top of Snowdon, the temperature here being very low, even in the middle of summer. On the morning of the 5th of July 1795, just after sunrise, Mr Aikin observed the thermometer at 34, whereas in the vale of Beddgelert, at seven in the morning, it was at 62; at one in the afternoon it had reached only 48 on the top of Snowdon.

The principal rivers in Caernarvonshire are the Rivers Conway and the Seicot. The first rises from a lake on the confines of Denbigh, Merioneth, and Caernarvon. Its course is nearly in a northerly direction, along the east side of the county, for about twenty-four miles, when it empties itself into the sea, at the town of the same name; it is half a mile wide at the Tash at high-water; and not above fifty yards at low, the remaining space being sand-banks, which, at high-water, are covered twelve feet. These sands still abound in the pearl muscle, as they did in the time of the Romans, but they have been long neglected. The Conway is navigable for about twelve miles. The Seicot rises from a lake near Snowdon; its course is westward, and it discharges itself into the Menai Straits at Caernarvon. The bay admits vessels of about 300 tons into the haven.

The sea coast of this county presents many ob-sea coast. jects worthy of notice. Traeth Bach, and Traeth Mawr, are two inlets of the sea having one entrance, and each receiving a little river; the greatest part of them are dry at low-water, and become quicksands. They lie between Caernarvonshire and Merionethshire, but as they seem more properly to belong to the latter county, the attempts of Mr Maddocks to embank the sands of Traeth Mawr, will more properly be noticed under Merionethshire. Passing from this county into Caernarvonshire, the first seaport is Pwllheli, on an inlet which receives three or four rivulets. It has a considerable coasting trade in small vessels. St Tudwell's bay is sheltered by two small islands. To it succeeds the bay named Hell's Mouth, from the height and form of the shores, which cause the wind to blow continually into it, while there is also a constant in-draught of the current. The promontory of Lyn extends to the west of the mass of mountains, that occupy the space between the west entrance of the Menai, and Traeth Mawr. At the extremity of this promontory lies the Isle of Bardsey, two miles long, and one mile broad; the tides run with great rapidity between this island and the promontory. The gulf between the peninsulated hundred of Lyr and Anglesea is called the bay of Caernarvon. It is lined by the high ridge of Snowdon. The only port on this coast is Porthyn Lyn, formed by a long point of land jutting into the sea, and sheltering a cove on the west. Port Penryhn, on a small rivulet, has been recently enlarged into a haven for vessels of 300 or 400 tons; from it are exported immense quantities of slate, from Lord Penryhn's estate in this county, to the amount of 500 tons a-week when the demand is great. About seven miles to the

Caernarvonshire.

west-south-west of Conway, on the road from that town to Bangor, is the stupendous precipice of Pen-mæn Mawr, the last of the long Caernarvon chain. It is 1400 feet perpendicular from its base, and, according to Mr Caswell, who was employed by Mr Flamstead the astronomer to measure it, 1545 feet above the beach at low-water. In 1772, application was made to Parliament to improve and secure the road across this precipice, which was accordingly done; and there is now a good road, on a ledge of the rock, defended by a wall five feet high. The county of Caernarvon is terminated by the lofty round promontory, called Llandudno, or the Great Orme's Head, on the east of the Conway river. It is a fine sheepwalk, ending in a steep precipice over the sea, which is hollowed into various inaccessible caverns.

Agriculture.

In consequence of the elevated surface of the greatest part of the county, and its cold, piercing, and damp atmosphere, there is little corn grown in it. Near the sea, however, and in some of the vales, barley of fine quality is grown; and in some of the higher districts, oats are cultivated. The vales yield a little meadow grass for hay, which is got in without the aid of wheel-carriages, the uneven surface of the ground not admitting their use. Sheep and black cattle, however, constitute the principal agricultural stock of the Caernarvonshire farmers. The former are pastured on the mountains, which, in general, are commons; and the latter on the lower grounds. A considerable quantity of cheese, made from the mixed milk of ewes and cows, is made. From the peninsulated hundred of Lyn, which is in general flat, oats, barley, cheese, and black-cattle, are exported; of the last, about 3000 annually. The numerous herds of goats, which used to frequent the rocky districts of this county, are now nearly extinct. There are some profitable orchards in the vales, but in general the climate is very unfavourable to fruit-trees.

Mineralogy.

Caernarvonshire is an interesting county to the Mineralogist; but we can only very briefly notice the principal features of its mineralogy. The highest and interior regions of the Snowdon mountains are composed of granite, porphyry, whin, and other primitive aggregate rocks, inclosing considerable blocks of quartz. The western side of Snowdon itself consists of ironstone, on which are placed basaltic columns, of different lengths, and about four feet in diameter. On each side of the primitive rocks, there are mountainous banks of slate, the coarsest on the eastern, and the finest invariably on the western side of the central ridge. At Nant-francon are the slate quarries of Lord Penryhn, who has constructed admirable railways from them to Port Penryhn. The banks of slate, growing finer as they descend, occupy the country between Snowdon and the Menai, usually terminating within a few hundred yards of its banks. The channel of the Shast, as well as its banks, consists of limestone; breccia, or the fragments of the Snowdon mountains, in a calcareous cement, and hard marl, inclosing shells. The general dip of the strata, in the promontory of Lyn, is to the south-west; on the north coast is chlorite slate and coarse serpentine.

On the former rest beds of primitive argillaceous schistus. The argillaceous schistus in some places is largely mixed with carbon, forming a kind of hard drawing slate; and in others it is penetrated by carbon and pyrites, forming alum slate. No mines have been opened in this district. A hard stone, used instead of brass, for supporting the pivots of light machinery, and another stone, something resembling the French burr, have been found in this county. There are some lead mines near Gwydir; but the most important and valuable metal found in this county is copper. The richest mines of it are in the vicinity of Llanberis; it is also found in various parts of the Snowdon mountains; and the green carbonate of copper lies between the limestone strata, in the promontory of Orme's Head. There are mines of calamine on the Caernarvon side of the river Conway.

Caernarvonshire
Caesalpinus

Many rare vegetables, met with only on the most elevated spots, grow in this county. Some of the steepest crags of the Great Orme's Head are inhabited by the peregrine falcon. Considerable quantities of fish, particularly herrings, are caught on the shores of this county; and lobsters and oysters are found in great abundance. In some of the lakes are found the char, and the gwyniad, another alpine fish. Foxes are the chief wild animals.

The money raised for the poor in 1803 was Poor Rate L. 9137, being at the rate of 4s. 0½d. in the pound. In the year ending the 25th of March 1815, there was paid in parochial rates the sum of L. 15,776, 17s. 6d. In 1800, there were 8904 inhabited houses, Population and 41,521 inhabitants; 19,586 males, and 21,935 females, of whom 12,808 were employed in agriculture, and 4234 in manufactures, trade, and handicrafts. The inhabitants live in a state of the utmost simplicity, manufacturing their clothes from the wool of their own flocks, and dyeing them with lichens: a little oatmeal added to the produce of their dairies constitutes their food. In 1811, the results of the population returns were as follows:

Inhabited houses,	-	-	9369
Families inhabiting them,	-	-	10,187
Houses building,	-	-	102
Houses uninhabited,	-	-	154
Families employed in agriculture,	-	-	6667
———— in trade, and manufactures,	-	-	2687
———— not included in the above head,	-	-	833
Males,	-	-	23,379
Females,	-	-	25,957

Total in 1811,			49,336
———— in 1800,			41,521

Increase in 1811,			7815

See Davie's *Agriculture of North Wales*.—Aikin's *Tour*.—Bingley's *Tour*.—Pennant's *Tour*, Vol. II.

(c.)

CÆSALPINUS (ANDREW), one of those great and daring geniuses, who, contending with the mists of a dark age, elicit the most brilliant truths on the one hand, while they sometimes wander into great absurdities on the other, was born at Arezzo

Spinus. in Tuscany in 1519. Of his family nothing is recorded, nor does he appear to have left any progeny, nor to have been ever married. Devoted to the studies of physic and natural philosophy, he attained at length the honour of being physician to Pope Clement VIII., during the chief part of whose pontificate, from 1592 till his own death in 1603, at the age of eighty-four, Cæsalpinus lived at Rome, in the highest credit and celebrity; for which, as we trace the circumstances of his history, and inquire into his opinions, it seems, at first sight, difficult to account. Eminent talents have seldom proved a shield against persecution. On the contrary, by adding fear to its malice, they have generally tended to envenom its darts. How then could Cæsalpinus, a professed Aristotelian, an open unbeliever of revealed religion, whose opinions nearly approached those of Spinosa, exist in the holy court of Rome, which was then beginning to persecute the immortal Galileo! This mystery will but too readily unravel itself.

Cæsalpinus seems to have been furnished with two distinct philosophical intellects, which, like a good and evil genius, directed him by turns. Under the influence of the one he discovered the circulation of the blood, the sexes of plants, and the only true principles of botanical classification; under the guidance of the other, he became entangled in the metaphysics of the schools, the dreams of Aristotle, and a philosophic contempt for everything, good or bad, connected with the nonsense he was obliged publicly to respect. It is scarcely necessary to remind the reader, that however brilliant the reign of literature and taste in the golden age of Leo X. and the times which immediately succeeded, true science and experimental philosophy were as yet in the cradle. In this respect the time of Cæsalpinus was "dark as Erebus," and the light he struck out was altogether his own.

We have no account of this great man, till we find him seated in the botanical chair of the University of Pisa, where also he studied, if he did not teach, anatomy and medicine. His first publication was entitled *Speculum Artis Medicæ Hypocraticum*, in which it were too much to expect he should release himself from the shackles of his venerable guide; but he has left evident proofs, in a passage often quoted, of his having a clear idea of the circulation of the blood, at least through the lungs. In botany his inquiries were conducted on a more original plan, and their result was one of the most philosophical works in that science, which came from the press at Florence in 1583, in one volume 4to. The title page runs thus: *De Plantis libri XVI. Andrea Cæsalpini Aretim, Medici clarissimi, doctissimique, atque Philosophi celeberrimi ac subtilissimi*; yet he appears to have been himself the editor of the work, to which is prefixed, in his own name, an elegant and learned epistle dedicatory to Francis de' Medici, Grand Duke of Tuscany. This book, now rarely to be met with, is not only the unacknowledged source from whence various subsequent writers, and especially Morison, derived their ideas of botanical arrangement; but it was a mine of science to which Linnæus himself gratefully avowed his obligations. His

own copy evinces the assiduity with which he studied the book. He has laboured throughout to remedy the defect of which Haller complains, of the want of synonyms, and has subjoined his own generic names, nearly to every species. He has particularly indicated those remarkable passages, in p. 13 and 15, where the germination of plants and their sexual distinctions are explained. In the former we trace the first rudiments of a natural classification of plants by the differences in their cotyledons; or, in other words, we find the origin of the natural systems of Linnæus and Jussieu; in the latter passage we detect the fundamental principle of the Linnæan artificial system. On these subjects the reader may consult our article on BOTANY. Nor were these merely incidental suggestions of the illustrious author. He has pursued his enquiries to a conclusion on which the existence of Botany as a science depends, and which the no less eminent Conrad Gesner detected about the same time, though his ideas respecting it were not then made public. The principle to which we allude is the classification of plants by their parts of fructification alone. This was afterwards extended, by the greatest writers on the subject, as Ray and Tournefort, and more completely by Linnæus, to the discrimination of their genera by the same parts, more particularly considered and contrasted. To this more extensive conclusion, indeed, the principle of Cæsalpinus directly and inevitably leads. He pursued it himself to such a length, as to develop some of the most important characters for generic distinctions, such as the flower being superior or inferior with respect to the fruit; the heart of the seed situated at its summit or base; the seeds, or the cells of the seed-vessels, solitary or otherwise; the partitions of certain pericarps parallel or contrary to their valves. Linnæus remarks that this author, though the first systematical botanist, found out as many natural classes, or orders, as any of his followers. He did not indeed well define the philosophical limits of genera in the vegetable kingdom, and therefore his work cannot regularly be quoted throughout for generic synonyms. The want of plates of his own, and of references to other authors, render, as we have already hinted, some of his names and descriptions unintelligible. Yet Linnæus has in manuscript filled up many blanks which he had been obliged to leave in his own *Classes Plantarum*, where the system of Cæsalpinus first assumed a synoptical form. This author might probably have adopted a more clear and methodical mode of arranging and explaining the botanical part of his subject, had he not had in view the vague and desultory manner of Pliny, whom he closely imitates in the materials of his numerous chapters, as well as in his style of description. A small and unimportant *Appendix* to this work, of 19 pages, appeared at Rome in 1603, which is of very rare occurrence, but may be found reprinted in Boccone's *Museo di Pisante rare*, p. 125.

Cæsalpinus printed at Rome, in 1596, a 4to volume of 222 pages, entitled *De Metallicis*, dedicated to Pope Clement VIII. which, like his botanical publications, is now extremely rare. In the philosophy

Cæsalpinus of this work, Aristotle is his guide; in its method and composition, Pliny. A prefatory address to the Pope declares it to have been undertaken in opposition to a certain treatise on the same subject, which, though written with diligence and elegance, contained many things inconsistent with the principles of philosophy, and subversive of the peripatetic doctrines; and with the author of which, as being excommunicated by the holy church of Rome, no measures were to be kept.

In our author's *Quæstionum Peripateticarum libri quinque*, published at Rome in 1603, it appears that he scrupled not to stand forth, as an open defender of the Aristotelian philosophy, without any concealment of his own peculiar opinions and hypotheses, derived from thence. By these he incurred the charge of atheism, from a physician named Taurel, who, punning on the name of his antagonist, entitled his book *Alpes cæsæ, hoc est, Andreae Cæsalpini monstrosa dogmata discussa et excussa*. This attack however met with little or no countenance, and the learned Aristotelian died in the course of the year, receiving, no doubt, in the very focus of sanctity itself, the funeral honours due to an orthodox physician of his holiness.

Of the medical publications of *Cæsalpinus*, entitled *Praxis univærsæ medicinæ*, and *De medicamentorum facultatibus*, we have had no opportunity of forming an opinion for ourselves. By what is to be gathered from his other writings, his ideas of the medical qualities of plants and fossils seem adopted from ancient writers, rather than from any considerable portion of actual experiment. Like other physicians of his time, he was too much occupied in ascertaining the articles of the *materia medica*, to find leisure for doubt, or for practical enquiry, respecting the truth of their reputed virtues. He did however promulgate some original ideas, relative to the investigation of the properties of plants by their taste and smell. With Botany he was not only theoretically but practically conversant. He left behind him a collection of above 760 dried specimens, one of the earliest upon record, which is said to have come into the hands of Micheli, and therefore is doubtless still preserved in the museum of Dr Targioni Tozzetti at Florence. A catalogue of this venerable *Herbarium* is reported to have been prepared for the press; but we do not find that it ever appeared.

Cæsalpinus having been settled at Pisa, when the great Galileo first presumed to doubt the infallibility of the Aristotelian philosophy; and, most likely, when that rising character became, at the age of twenty-six, Professor of Mathematics in the same university; we cannot presume him to have been free from the party spirit which so disgracefully manifested itself there. He must have concurred in the measures which his own associates, leagued with the ruling powers, thought proper to adopt. The ancient school philosophy, derived from the Peripatetics, whether it was considered as a mere abstract speculation, or whether, as being equally absurd and unintelligible with the orthodox establishment, it did not excite alarm, was, as every body knows, allowed to go on very lovingly with that establishment; nor did it, in general, raise any more suspicion than the

heathen mythology, studied and exemplified in the same and other schools. But when a spirit of truth and enquiry arose; when principles and opinions were to be submitted to the tests of reason and experiment; the same fatal results, which the preceding age had witnessed in what was called religion, were justly apprehended for what was now, with scarcely more propriety, denominated philosophy. Hence the papal authority, which had suffered shipwreck in the one case, wanting the wisdom to avoid a similar disgrace in the other, gladly clung for support to any ally. These two celebrated occasions, the divorce of Henry VIII., and the base persecution of Galileo, are almost the only ones in which the authority of the Pope has been exerted about any matter that human reason could determine, or that much signified, except to his own immediate dependants, how it might be determined. It is a memorable fact, that his decision was no less just in one case, than unjust in the other; yet both were equally ruinous, the former to his power, the latter to his credit. So hazardous is the exercise of usurped or over-strained authority, and so infallibly, thanks to the Author of all Good! do truth and justice rise, with renovated vigour, from such contests!

By this view of our subject, the mystery above alluded to becomes clearly unravelled. *Cæsalpinus*, though a known heretic and infidel, professing to be an obedient son, and even a champion, of the church, tried to rise by the ruin of equally learned, and more honest, men than himself. On the side on which he was aboard and censurable, and on that side only, he was unjust and unprincipled; nor is such a character uncommon. Where he exercised his unbiased judgment, and honestly sought for truth, he, like Galileo, enlarged the bounds of human knowledge, and made discoveries which will for ever claim the gratitude and admiration of mankind. (J. J.)

CAITHNESS, a Scottish county, the most northern of the mainland of Great Britain, is situated between 56° 20' and 59° of north latitude, and between 2° 50' and 3° 27' west longitude; and, including the island of Stromna, in the Pentland Frith, extends over 618½ square miles, or 395,600 English acres, of which 3414 acres are covered by lakes and other waters. About a fourth of the surface is mountainous, more than a half consists of deep mosses, and only about an eighth part is cultivated. The boundaries, pronontories, bays, climate, wild animals, &c. having been particularly described in the corresponding article in the *Encyclopædia*, we shall confine our notices at present to what is omitted there, and to the alterations which the progress of time has introduced.

This county is divided into thirty-four estates, eight of which comprise two-thirds of the rated rent, which is L.37,266, 2s. 10d. Scots; and more than a third of the whole is held under entail. Nine proprietors of the names of Sinclair, one of whom is a Peer, hold more than the half of this valuation. The real rent, for the year ending April 1811, was Rated for the lands L.30,926, 1s. 9d. Sterling; and for the houses L.1,698, 7s. 6d. The Earl of Caithness is the only nobleman who resides in, or is connected

with the county; most of the other proprietors have modern mansions, and reside, at least a part of the year, upon their estates. Rents in this, as in almost every part of Scotland, have experienced a very great advance within the last fifty years; in one instance, noticed in Captain Henderson's survey of the county, published in 1812, nearly eight-fold, from 1762 to 1809. In 1792, Sir John Sinclair established a flock of Cheviot-sheep on his farm of Langwell, which have been found to prosper in that climate; and several other spirited improvements were about the same time promoted by this gentleman, though unfortunately they have not been attended with all the success that their indefatigable, but perhaps too sanguine, projector had contemplated. Several other proprietors have shown a very laudable zeal for the interests of this remote, and, till of late, much neglected quarter of the island. About twenty-four years ago, an act of Parliament was procured for commutating the statute-labour, under which L.550 has been annually expended on the repair of roads; and, within these few years, the proprietors have availed themselves of the aid granted by Parliament to the northern counties, of half the estimated expence necessary to make the great lines of road; more especially from the Ord to Wick, and from Wick to Thurso. No attempts to raise plantations in this county have yet been successful, though it appears, from the trees found in mosses, that woods had formerly grown, even on the sea-coast. As a great part of the county is nearly level, the want of plantations is much felt in this rigorous climate.

It has been the practice in this county, from time immemorial, for a few of the superior class of farmers, under the name of tacksmen, to take a lease for 19 or 21 years of a town land, occupied by from 10 to 40 small farmers, at a rent commonly paid in money, and not partly in kind, as was the case with smaller tenants. These men occupied only a part of the lands themselves, and sublet the remainder to small tenants, for a certain money rent, payments in grain, customs, and services (the latter in many cases unlimited), so as to have, upon the whole, a surplus rent for the trouble and risk of recovering their rack-rent from these subtenants. Through this arrangement has been much, and perhaps justly complained of, both in the Highlands of Scotland and in Ireland, as oppressive to the lower classes, yet it seems to be the natural consequence of that minute division of farm-lands which has been so injudiciously recommended for improving the condition of the poor. The surplus rent drawn by the tacksmen is merely a charge against the proprietor for factorage and insurance; and, notwithstanding the oppression of the small tenants, which may be the consequence of thus placing them at the mercy of one who must have a much slighter interest in their welfare than the proprietor himself ought to feel, yet there appears to be no remedy but such a one as would dislodge these small tenants altogether,—the enlargement of farms to such a size as would make them an object to professional farmers. A few young men, from the south of Scotland, have taken farms here, but it is said they have not been successful in esta-

lishing a mode of management superior to that of the natives. A great part of the county, accordingly, is still divided into small holdings, of which the rent is paid in money, in the Highland district of it; and, in the Lowlands, partly in money and partly in grain; and in some instances, with customs, casualties, and services, as formerly. When the small tenants possess upon leases, the term is commonly too short to encourage any expensive improvements, or even to permit any favourable change in their modes of cultivation.

The implements of that numerous class are, in Agriculture, extremely rude and inefficient: ploughs and harrows, entirely of wood, excepting some thin plates of iron nailed to the sole of the farmer, to prevent its wearing by the friction of the soil, with four ponies or oxen yoked abreast, attended by a driver who walks backwards according to the ancient custom; seldom even a winnowing machine to separate their grain from the chaff,—and fences formed by a ditch and sod-wall. Their crops are bear and oats, alternately on the infield or old tillage lands, and grey oats successively, for four or five years, on the outfield or inferior land. Wheat has been tried by a few proprietors, but it does not succeed so well in that climate as to encourage its extensive culture. Turnips are beginning to attract notice among the small tenants, and to come into the regular course of cropping on large farms; and potatoes are now cultivated with the plough, as well as with the spade, in every part of the county. The cattle in Caithness have been long the worst breed in Scotland; but a considerable improvement has been lately effected on some estates, by the introduction of bulls from Argyleshire and the Western Isles. Oxen continue to be worked with the plough and harrow. With the exception of a few flocks of the Cheviot breed, the sheep are of the ancient race of the island, mostly horned, bearing a white fleece, but coarser than the wool of Shetland, and weighing from seven to ten lbs. per quarter. Since two-horse ploughs have been partially established, some attention seems to be paid to the breed of horses, though the *garrows* from 11 to 14 hands high, are still by far the most numerous description. The native breed of swine is small, short bodied, and generally of a redish or grey colour; there are a few black, but the grey are reckoned the best.

In a county where the want of coal is added to the many disadvantages under which it labours from its soil, climate, and other circumstances, it is not to be expected that manufactures or commerce should have acquired any footing. A tannery, bleachfield, and woollen factory, were long ago undertaken under the direction, and chiefly at the expence, of Sir John Sinclair, of which only the first has been found profitable. A brewery is still carried on at Thurso; and a small ropework in the village of Castletown. In winter 1810, about 250 women and girls were employed in Thurso plaiting straw for ladies' bonnets; the straw-plait being returned to London, from whence the straw itself is imported. Caithness exports a few cattle and sheep, but of the former not a tenth part of what has been stated by Pennant. About twenty years ago from

Caithness-shire.
Small Farms.

Commerce.

Caithness-shire.

Fisheries.

John-o-Groat's House.

Picts Houses.

20,000 to 30,000 bolls of grain were annually sold out of it, but the quantity has diminished; and there used to be about 140 tons of kelp prepared from the sea-weed on its shores. But their fish form the most important article of export. Herrings, cod, lobsters, and salmon, bring in L. 43,400, of which the herring-fishery alone yields L. 40,000. Besides a great number of boats employed in the several creeks and harbours in fishing for haddock, ling, &c. which are consumed in the county; about twenty smacks from Gravesend fish for cod and ling, on the north coast of Caithness, and are said to have, in a great degree, destroyed the cod-fishery on its shores.

Among the antiquities of this county, the far famed *John-o-Groat's* house deserves to be noticed. The tradition regarding this celebrated personage is, that his ancestor came from Holland, and settled in this county in the reign of James IV.; and that he built this house of an octagon form, inclosing a large table of the same shape, to obviate disputes about precedence, at their anniversary meetings, among the Groats in his time, consisting of eight families. Each family, by this contrivance, entered separately at its own door, and was seated at the corresponding side of the table. A variety of these singular structures called Picts Houses, are still to be seen in Caithness. Many of the stones are of an enormous size, and must have been brought from a distance; fragments of earthen-ware, and a few small copper coins, have been found in them; and some singular articles made of bone fixed with nails of the same material. They are almost always of a conical form, and their exterior being now covered with a thick sward of fine grass, they have the appearance of large tumuli or barrows. The internal structure, as well as the size of these *Duns*, as they are called by the Highlanders, is various. The smallest, and apparently the oldest, have only one circular wall which contracts as it rises, till, at the top, only a small hole must have remained open, or been covered with flat stones.

The largest ones have two concentric walls, two feet distant, which in some instances meet at a certain height, and in others ascend parallel to the summit; the space between them being entered by a door only two feet high, and occupied by a winding stair from the bottom to the top of the building; and these are surrounded by a broad deep ditch, and a sort of rampart. The walls are usually nine or ten feet thick, without cement of any kind; and from their situation on high land near the sea, or on the banks of precipitous rocks, stretching in a chain from one headland to another; they are supposed to have been used either as storehouses, or as retreats for women and children when the men were at a distance engaged in war.

The county of Caithness sends a Member to Parliament alternately with Buteshire, on the west of Scotland, an arrangement which of late has been much objected to, not only because one of these counties must always be without a representative, to which each, it is thought, is entitled, but also because there can be hardly any common interest between districts so distant from one another, and placed in circumstances so different. Five of the northern boroughs, of which Wick, the only royal borough in this county, is one, join together in the election of a Member for that department.

On the low grounds, the people differ little in their dialect from the inhabitants of the south of Scotland; but on the mountainous tract, where Caithness borders with Sutherland, the Gaelic prevails; though many of the natives can speak both languages with nearly equal facility.

By comparing the population lists taken under the acts 1800 and 1811, it will be seen that, even in this remote and comparatively unproductive portion of the British Empire, there has been an increase of numbers in the intermediate period, though not so considerable as in most other counties. The inhabitants of the towns bear a very small proportion to those of the country.

1800.

HOUSES.			PERSONS.		OCCUPATIONS.			Total of Persons.
Inhabited.	By how many Families occupied.	Uninhabited.	Males.	Females.	Persons chiefly employed in Agriculture.	Persons chiefly employed in Trade, Manufactures, or Handicraft.	All other Persons not comprised in the two preceding classes.	
483	4652	140	10,183	12,426	13,263	2201	7145	22,609

1811.

HOUSES.			PERSONS.		OCCUPATIONS.			Total of Persons.
Inhabited.	By how many Families occupied.	Uninhabited.	Males.	Females.	Families chiefly employed in Agriculture.	Families chiefly employed in Trade, Manufactures, or Handicraft.	All other Families not comprised in the two preceding classes.	
4301	4714	189	10,608	12,811	3270	838	606	23,419

(A.)

CALCUTTA. The *Encyclopædia* contains some account of the settlement and subsequent improvement of Calcutta; and in the present article, which is compiled from the works of recent writers, we have endeavoured to comprehend whatever is most useful and interesting in the description of this celebrated city.

Calculta is situated upon the river Hooghly, which forms the western channel of the Ganges, and though not the principal, is the only one of its numerous branches which is navigable for large vessels. The town is 100 miles from the mouth of the river, the navigation of which is difficult and often dangerous, on account of its numerous sand-banks, many of which are continually shifting their situation. Vessels drawing more than seventeen feet water cannot, except at spring-tides, ascend with safety above Diamond Harbour, where the vessels of the East India Company usually load and unload. This is about sixty miles below Calcutta, and passengers are conveyed to the city in smaller vessels or in boats. The country, from the mouth of the Hooghly to Diamond Harbour, is dreary in the extreme; the banks of the river are high, and the adjacent land, on each side, which is perfectly flat, forms a complete wilderness of timber and brushwood, the haunt of tigers, and of other beasts of prey. Advancing up the river, the scene gradually improves; the country becomes more and more cultivated, the shipping and the bustle on the river increase, and the beautiful country-seats on its banks announce the approach to the capital. The city, with its numerous spires and other public edifices, presents, at a distance, a striking appearance; and, on landing, the magnificence of the buildings command the admiration of all strangers. The town and suburbs extend along the left or eastern bank of the river above six miles, but varying much in breadth at different places. In the middle of it, and very near the landing-place, is an immense square, each side of which extends above a quarter of a mile, and the centre is occupied by a large tank or open reservoir of water, for the supply of the town. This square, together with the adjacent buildings and those towards the south, forms, what is properly termed, the town of Calcutta, the residence of the European inhabitants and of the natives of distinction. To the south, along the bank of the river, lies the Black Town, which is occupied entirely by the lower classes of inhabitants, and is rather considered as part of the suburbs; and about a quarter of a mile to the north stand Fort-William, and the barracks, which form, on this side, a great ornament to the city. The intermediate space, which is an extensive open plain, is termed the Esplanade. The citadel of Fort-William, which was begun by Lord Clive in 1757, after the battle of Plassey, is the strongest and most regular fortress in India, but the works are so extensive, that they would require at least 9000 or 10,000 men, with 600 pieces of cannon, to defend them. On the west of the Esplanade stands the government-house, built by the Marquis Wellesley, which is the largest and most splendid building in Calcutta. It is the residence of the Governor-General, where he holds levees, and transacts all the

government business; it also contains magnificent apartments for public entertainments. The other principal buildings are a town-house, with public rooms, which, though handsome, are too confined for the climate, and for the number of inhabitants; the hospital and jail, which are situated on the Esplanade; two English churches, the one of which is a plain building, but the other has an elegant appearance; also a Scottish church, which is newly finished; and, besides these, there are various churches belonging to the professors of almost every religion in the world. Portuguese, Greeks, Armenians, Hindoos, and Mahomedans, all enjoy here the most perfect toleration.

The customhouse faces the river, and forms part of the west side of the great square. It is built upon the site of the old fort, which was taken in 1757 by Surajah Dowla. Near to it is the famous Black Hole, which is now converted into a warehouse; and before the gate stands the monument which has been erected to commemorate the unfortunate persons who perished there. It is surrounded by an iron-railing, but it has been struck with lightning, and has since been allowed to go to decay. In front of the customhouse is the quay, which has been of essential service to the numerous shipping which there load and unload. On the west side of the river, and in a beautiful situation, stands the botanic garden, at a bend to which it gives the name of Garden Reach. It contains a splendid collection of plants from every quarter of the globe, and is laid out with great taste, but more with a view to practical utility than scientific arrangement. Above the garden there is an extensive plantation of teak. Horse-racing having been discouraged by government, the course, which was to the south of the town, is now converted into a ride; but the practice still continues at Barrackpore, sixteen miles up the river, where the fashionable society of Calcutta assemble to partake of the amusement. The south side of the great square is occupied by the writers' buildings, which make but an indifferent appearance. They form the residence of this class of the Company's servants who are newly arrived from Europe, and who are students at the college of Fort-William. The private houses in Calcutta, in the central or genteel part of the town, are built, mostly, after the European fashion, but modified to the nature of the climate, and to the magnificence of eastern manners. In a line with the government-house, is a range of elegant buildings, ornamented with large verandahs, and another, at right angles with it, called Chouringee, formerly occupied by native huts. These houses are built of brick, covered with a species of stucco called Chunam. They are all separated from each other, every one having attached to it a considerable piece of enclosed ground, in the middle of which it is situated. The approach is by a flight of steps, under a large portico. The architecture is Grecian, and the profusion of columns, porticos, and verandahs, gives them more the air of palaces than of private houses. To this part of Calcutta the Black Town forms a striking contrast. It has been already described in the *Encyclopædia*, but has been considerably improved

Calcutta. by the widening of the streets, the filling up of ponds, and by tiling instead of thatching the houses, by which means the danger from fire has been much diminished.

Though building materials are abundant in the neighbourhood of Calcutta, house-rent is not moderate. This is owing partly to the high interest of money, and partly to the constant repairs which are required, from the casting of the wood in this hot climate, and from the ravages of insects, particularly the white ants. Though the wood-work of a house appear externally quite sound, it often turns out upon examination to be completely excavated or honey-combed by these insects, which assemble in incredible numbers, wherever they can find an entrance.

Precautions to be observed by Strangers.

The houses here, which are known under the name of taverns, are greatly inferior in respectability to those in Europe. They are, with the exception of two or three particular houses, resorted to only by the lowest company, and strangers who are enticed into them are exposed to every species of imposition, and frequently to total ruin. A European, on his first landing, is surrounded by numerous dangers and inconveniences, which he finds it extremely difficult to escape. These are so well described in the *East India Vade-Mecum*, by Captain Thomas Williamson, that we shall extract the following passages, for the instruction of such of our countrymen as propose to visit those distant regions.

"The tavern-keeper, under the plausible pretext of aiding towards the completion of the youth's wishes, never fails to inquire whether the gentleman has any friends in town? or even in the country? If affirmatively answered, 'mine host' feels himself tolerably secure of his money: but will probably assert, that the friend in town is out of the way, and will not be back for some days. Should the gentleman be totally destitute of friends, then comes the rich harvest. Imposition following imposition, swell the bill; which, if appearances warrant forbearance, is kept back as long as possible, under the pleasing assurance of perfect confidence: but, in the end, a catalogue of items is produced, which never fails to alarm, if not to ruin, the unsuspecting victim!"

"If, unhappily, the guest should so far lower himself as to associate with the ordinary company of the common drinking-room, he is irretrievably gone. Quarrels, riots, and inebriety, must follow; in all probability rendering him subject to the notice of the police. Should his face ever be seen at that office, it would be next to impossible that he should be admitted into any respectable circle. What with lodging, dinners, wines, &c. of the worst description, but all rated at the highest prices, he must be a fortunate wight who escapes under a gold mohur (*i. e.* two guineas) per day: in general, double that sum is charged; so that a person starts at the rate of L. 1000 per annum, at least; while, in all probability, no established, or even apparent, provision exists, whereby he may be maintained."

"To state the evil, without pointing out the remedy, would be next to useless; but, when I suggest the means of avoiding those difficulties, or any portion of them, attendant on arrival in a foreign land, it must be understood, that I consider the stranger to

be possessed of pecuniary means: that is, that he can pay his way. Without this, he can do nothing; and must undergo all the afflictions and miseries attendant upon despised poverty, in every part of the globe. It may be proper to point out in this place, that what might here appear to be liberal calculations, would not suit the East; where every article of European manufacture bears so enormous a price, where house-rent is so expensive, and where it is indispensably necessary to retain so many servants. The first thing to be done (setting a letter of recommendation out of the question) should be to report arrival at the Secretary's Office, depositing the certificate of the Court of Directors' licence to proceed to India; without which, the party is considered as an alien, and scarcely considered as entitled to British protection. This does not arise from ill-will on the part of government, or of the inhabitants; but from that strict attention the politics of the country imperiously demand to be paid to the several characters, and descriptions, of persons residing within our territory.

"The above relates equally to all persons in the civil or military branches; the certificate granted at the India House must be produced, in order to identify the party; but if it should have been lost, he himself, together with the commander who received the order for taking him on board, must attend to make affidavit to that effect, before the appointment can be admitted upon the registers in India.

"Such as appertain to the civil service, being always strongly recommended, and often finding many old acquaintances of their families on the spot, require but little advice; nor does the cadet stand much in need of instruction, as to the manner in which he should provide himself with a home. All he has to do, is to wait upon the town-major, at his office in Fort-William, when he will receive the necessary order for his admission into the Cadet Corps at Baraset, about sixteen miles from Calcutta.

"He who has not these advantages, must do the best his circumstances may afford; he will find temperance to be not only cheap, but indispensable; for, if he should act so indiscreetly at the outset as to injure his health, a thousand privations, and a certain increase of difficulties, must follow. The first point must necessarily be to get under cover. This will not be found so easy, as those who have never quitted England may suppose. It will be after much research, that a small house will be had, and then only the bare walls; for no such thing is known in India as a furnished house to be let; and lodgings are, if possible, still more out of the question. Fortunately, there are, among the European shopkeepers in Calcutta, some most respectable characters; men distinguished for their urbanity, philanthropy, and generosity. Application should be instantly made to one of these firms, for aid and advice. The case should be candidly stated; and, in order to insure confidence, a deposit of money should be made, either with them, or at one of the banks. The consequences will be, that, in a few hours, some small tenement will be obtained, either on hire, or granted as a temporary accommodation, and the whole of the articles really necessary will be provided, at

Calcutta. some one or other of the auctions which daily take place within the central parts of the town."

Commerce. Calcutta is the great emporium of the east. By means of the Ganges, and its tributary streams, it has an uninterrupted water communication with the whole of the north of Hindostan, on the one hand, and with the whole of Europe, Africa, America, and great part of Asia, on the other. Thus advantageously situated for commerce, it trades extensively with almost every country in the world, and numbers of vessels of every form and description are constantly arriving or departing from the river, which, in the vicinity of the town, presents the busiest scene imaginable. Numerous dock-yards have also been established, in which are built vessels of great burden and of admirable construction. Piece-goods, shawls, indigo, silk, sugar, opium, and rum, are the staple commodities of export. Treasure is imported from all quarters. From London, the imports consist principally of articles of consumption for the European inhabitants, consisting of porter, ale, confectionaries; and, generally, of all the finer manufactures.

Public Establishments. In 1808 a bank was established at Calcutta, under the name of the Calcutta Bank. Its capital amounts to 50 lacks of rupees, of which ten were subscribed by Government, and the remainder by individuals. There are twelve Insurance Companies. Several newspapers are published weekly. The charitable institutions are numerous. Of these the principal are two schools for the education and maintenance of the children of Europeans in the military service of the Company, one for the children of officers, and another for those of privates; a free school at which about 100 children are educated, and a native hospital or infirmary. The Asiatic Society still continues its sittings, and publishes its Transactions, which contain much interesting matter concerning the history, literature, languages, and antiquities of Asia. An Auxiliary Bible Society has also been established at Calcutta.

Supreme Court. The Supreme Court consists of a Chief-Justice and two puisne judges, all nominated by the Crown. Its jurisdiction extends to all British subjects in India, and to all civil actions between natives, or between natives and Europeans. Criminal cases are tried in this Court by a jury, consisting exclusively of British subjects; as also all criminal charges against the Company's servants, and all civil actions in which the Company, or any of its servants, are concerned; but it takes no cognizance of the land revenues. The law practitioners attached to this Court are fourteen attorneys, and six barristers.

College of Fort William. The College of Fort William, for the education of the junior servants of the East India Company, which promised at one time to be so great an establishment, is now reduced to a few lecture rooms in the Writers' buildings. It was begun in 1801 by the Marquis Wellesley, then Governor-General, and its object was to remedy the evils which had arisen from the ignorance of the Company's servants; to fill, if possible, the important situations of the Empire with men of learning, talents, integrity, and moderate habits; and along with a just administration of government, to spread the influence of literature, science, and the Christian religion, over the eastern world.

VOL. II. PART II.

The arrangements of the institution seemed well adapted in many respects for this purpose. But the extensive nature of the plan did not meet the views of the Court of Directors, and in June 1802, their instructions were received for its abolition; the period of which, however, the Governor-General delayed for various reasons till December 1803, having, in the meantime, addressed to the Directors a strong defence of the institution. In January 1804, instructions were received to continue it on its original footing. The institution accordingly proceeded with new vigour. All promotion to the service was made through the college, and was regulated entirely by the merit of the students, among whom an unexampled emulation in literary pursuits had arisen. In four years from the time of its establishment, one hundred original volumes in the oriental languages and literature had been published, and the plan of translating and printing the Scriptures in all the languages of the east had made great advances. In 1805, the students of the establishments of Madras and Bombay were separated from those of Calcutta; in consequence of this reduction of the extent of the college, the duties of the Provost and Vice-Provost were united by a minute of the Governor and Council in one person, under the title of Provost; and in January 1807, the offices of Provost and Vice-Provost were abolished; the Professorships were restricted to three,—those of the Hindostanee, Bengalee, and Perso-Arabic; the period of attendance was reduced to one year, and all control over the private expences or conduct of the students was given up. On this reduced and limited footing the establishment still continues.

Population. The population of Calcutta, which is stated by some to amount to 500,000, by others to 700,000, is composed of persons from every quarter of the world. British, and other Europeans, Armenians, Persians, Chinese, Hindoos, and Mahomedans, are all seen mixing in the streets of this metropolis. The occupations of these various classes are nearly what might be expected in the luxurious capital of a great Empire, and in so great an emporium of maritime commerce. Public officers, lawyers, physicians, merchants, and their families, make up the bulk of the British inhabitants. The natives and foreigners of respectability are mostly engaged in trade, or living upon their property, and the lower classes are principally composed of retail-dealers, mechanics, and servants.

The British merchants form a most respectable **Different Classes of Merchants.** class of men, and contribute essentially to the prosperity of the settlement; many of them are possessed of large fortunes, and live in a style of suitable splendour. The Armenians are the most numerous body of foreign merchants in Calcutta. They trade extensively to all parts of India and China, are uncommonly diligent and attentive to business, and are considered to have the most minute intelligence from foreign ports of any other body of merchants. The native bankers, agents, and money-dealers, are numerous. Though formerly timorous, the Hindoo now adventures in almost every species of mercantile speculation; and cloths belonging to the native merchants, to the amount of

4 c

Calcutta L. 1,000,000 Sterling, are generally lying for sale in the warehouses of Calcutta. The native merchants of an inferior class, engross nearly the whole of the retail trade of Calcutta, under the titles of Banians, Sircars, and Writers; and they are generally described as fond of money to excess, and most unprincipled in all their dealings.

Cold and Hot Season. The cold season, which lasts from September to April, is generally allotted to amusement and festivity in Calcutta. It is only during part of this season that it is possible to venture abroad in the heat of the day, which, in the rest of the year, is devoted to repose. The hot season begins in April. Every day the heat increases until the middle of June, when the periodical rains begin, and last till August. The weather then being extremely close, is more oppressive, and more unhealthy than before. The thermometer, throughout the year, generally ranges between 75° and 95°, but frequently rises to 100° and 110°.

Markets. The markets at Calcutta are open at day-break, and they afford, at very moderate prices, meat of every kind, and poultry, with various kinds of choice fish, fruits, and vegetables; also game, such as wild ducks, partridges, snipes, &c. with various kinds of ortolans. The wild venison is not nearly so good as that of Britain, but the park or stall-fed is equally good. The hare is very different from that of England, being defective in size, strength, and swiftness.

Rise of the Ganges called the Bore. That sudden rise of the waters, termed the *Bore*, is quite common on the Hooghly, as well as on the other branches of the Ganges. The general cause of this appearance is sufficiently understood, but it is not easy to explain the details. It is common on several of the rivers in England; it is also known on the waters of the Dordogne and Garonne in France, under the name of *Mascaret*, and in the Amazons in South America, where it is termed the *Proruroco*. It is an immense wave, which, in the Hooghly, heads the spring flood-tide, travelling before it, at the rate of 80 miles an hour; and, what is most singular, not occupying the whole breadth of the stream, but ranging along one of the banks, and crossing over to the opposite shore at every considerable bend of the river. It begins about 40 miles below Calcutta, and is felt, but with continually decreasing effect, nearly as far above it. At Calcutta it ranges on the opposite bank. The swell is prodigious; and, on its approach, all the small craft fly for safety to the middle of the river, where, though the swell is still considerable, they are not exposed to the same imminent danger. At Calcutta it often causes an instantaneous rise of the water of five feet.

See Williamson's *East India Vade-Mecum*, 2 vols. 8vo. 1810.—Lord Valentia's *Travels*, 3 vols. 4to. 1811.—Mrs Graham's *Journal of a Residence in India*, 4to. 1812.—Hamilton's *East India Gazetteer*, 8vo. 1815.—Milburne's *Oriental Commerce*, 2 vols. 4to. 1813.

(o.)

CALEDONIAN CANAL. The importance of this great national undertaking, whether considered as a work of magnitude and expence, as tending to open up and improve some of the most barren and rugged districts in Scotland, or to facilitate the

intercourse between the eastern and western sides of Great Britain, by rendering unnecessary the navigation of a circuitous and dangerous coast, induces us to treat of it separately, and to furnish our readers with a correct map or plan of its line, reduced from the maps laid before Parliament.

So early as the year 1778, Mr James Watt of Soho; to whom mankind and the arts are much indebted for his improvements in the steam-engine, was appointed by the Trustees or Commissioners for certain Forfeited Estates in Scotland, to make a survey of the central Highlands. Mr Watt, in his Report to that public body, recommended, amongst other improvements for the Highlands, the formation of the Crinan Canal, which has long since been executed, and also of the Caledonian Canal, from Inverness to Fort-William, now in progress, and which we are immediately to describe.

The late rapid introduction of the sheep-farming system having necessarily deprived multitudes of the inhabitants of their former means of subsistence, the formation of roads and canals, and the multiplication of fishing stations, came to be looked to, as affording the most likely means of mitigating the evils consequent upon this great and sudden change of system; and in pursuance of this view of things, the Lords of the Treasury, in 1802, directed Mr Telford, Civil Engineer, to make a survey of the coasts and central Highlands of Scotland. The Report which he in consequence drew up, involves a variety of considerations connected with the improvement of the Highlands, and the employment of the population of these districts; but the part of it which we are more particularly to consider, is that which refers to the proposition of an inland navigation from Loch Beaul and the German Ocean on the eastern coast, to Loch Eil and the Atlantic Ocean, on the western coast. Mr Watt proposed that the depth of this canal should be ten feet, or two feet more than the Forth and Clyde Canal; but Mr Telford, considering the great command of water from the chain of lochs or lakes in its line, and aware no doubt of the advancing state of maritime adventure, and of the inconveniences which are felt from the small scale on which that navigation has been executed, though originally termed the *great canal*, was induced to propose a depth of twenty feet for the Caledonian Canal; that it might thus be capable of floating twenty-eight gun Frigates, and the largest class of Baltic traders.

The Parliamentary Committee, which had been appointed in reference to the situation of the Highlands, had corresponded with the Highland Society of Scotland as to the means of improvement; and, before finally reporting upon this great and bold plan, they called before them the most eminent Engineers, nautical Surveyors, Mariners, and Merchants in the kingdom. In particular, Mr Jessop and Mr Rennie, Civil Engineers, were severally examined with regard to the practicability and expence of the plan proposed by Mr Telford; and Captain George Duff, of the Royal Navy, Captain Huddart of the Trinity House, London, Lieutenant Gwynn, Commander of the Fort-Augustus galley on Loch Ness, and several others, were examined upon points touching the navigation and anchorage for large vessels.

Caledonian Canal. Returns were also procured from the ports of Dublin, Liverpool, Greenock, Leith, and Aberdeen, regarding the probable advantages of the proposed inland navigation, and to what extent it would be useful. This Committee, after much investigation, reported as follows :

“ Your Committee, from a full consideration of all the evidence laid before them, and annexed to this Report, by way of Appendix, submit to the House their opinion: That the execution of the inland navigation, proposed in Mr Telford's plan, under all due regulations, for the economical expenditure of such monies as may be employed in this great work, will be a measure highly conducive to the prosperity and happiness of that part of Scotland in which it is situated, and of great importance to the general interests of the whole United Kingdom.”

First Act of Parliament. A Bill was, accordingly, brought into Parliament, on the Report of this Committee, in the Session of 1803, entitled, “ An Act for granting to his Majesty the sum of L. 20,000, towards defraying the expence of making an inland navigation from the Eastern to the Western Sea, by Inverness and Fort-William; and for taking the necessary steps towards executing the same;” which Act received the Royal Assent on the 27th day of July 1803.

The Board of Commissioners for the Caledonian Canal, appointed by this act, accordingly met, and made certain arrangements for the immediate commencement of the work; having, in the first place, appointed Mr Thomas Telford to be their Engineer. He had formerly been employed by the Lords of the Treasury in making various surveys of the Highlands. But in so important an undertaking, the Commissioners judged it necessary to call to his assistance Mr William Jessop, another eminent and experienced Engineer. Mr Telford, instructed by the Commissioners, proceeded immediately for Scotland, and again made an entire survey of the whole line of the canal from Inverness to Fort-William. To ascertain the soil, trial-pits and borings were made from shore to shore, at distances not exceeding half a mile. Mr Murdoch Downie, an experienced Marine and Nautical Surveyor, was employed to make a survey of the chain of lochs upon the line, in order to sound and determine their respective depths and anchorages. The line of the canal, where *cutting* was necessary, was now carefully laid out. Stone and lime quarries, timber and other necessary materials were looked after, and some idea was formed as to the probable value of the land to be passed through. Places were also fixed upon for the entrance-basins or sea-locks, at both extremities, and every possible information prepared for Mr Jessop's survey, which took place in the month of October. He was met by Mr Telford at Edinburgh, and these gentlemen proceeded together to a full examination of the whole; and, upon this survey, Mr Jessop reported his opinion to the Commissioners, and furnished an estimate of the expence. The chief difficulties alluded to in his Report, as incident to this great work, refer to the cutting new channels or courses for the rivers Ness, Oich, and Lochy, the deepening Lochs Doughfour and Oich by excavation,—the damming up and raising the surface of Loch

Lochy, which is about ten miles and a half in length, to an additional depth of twelve feet,—the *spilling* or running off its flood-waters by a new cut into the River Spean; and some extra cutting at the summit level between Lochs Oich and Lochy. But one of the most difficult parts of the navigation, is stated to consist in the deepening and management of Loch Doughfour. Mr Jessop seems to have been prepared to meet with rather an unfavourable soil for canal operations; he was of opinion, that the whole valley between Loch Ness and Fort-William, has been one entire sheet of water; and that the portions of land intervening between the lochs are the *debris* of the adjoining mountains. The first *trial-pits* dug in the neighbourhood of Inverness, did not fail to give some alarm upon this subject, as the ground consisted of sand and gravel so open and porous, that the tidal waters of Loch Beaully flowed and ebbed through it. But on other parts of the line of the canal, the gravel was found to have such a mixture of earthy particles as would be sufficient to render it impervious to water.

The extent of canal to be formed and cut, is stated to be about 21½ miles, and the loch or lake navigation at 37½, making a total distance of inland navigation from sea to sea of about 59 miles; the bottomwidth of the cutting 50 feet, with slopes of 18 inches to a foot, with *benchings* at the water-line, making the width at the surface to be about 110 feet. The general dimensions of the canal, though afterwards enlarged, were now estimated at 20 feet for the depth; the width of the locks is taken at 38 feet, and their length at 162 feet. The number of locks is estimated to be 23. They are to be built of masonry, with gates and platforms of American pitch-pine. After critically examining the whole intended line of the Caledonian Canal, its proposed dimensions, soil, materials and workmanship, Mr Jessop estimated the expence at the sum of L. 474,531, including 8 per cent. for contingencies; but exclusively of the price of land, and the necessary moorings for the anchorages at the respective lochs. Upon a joint Report afterwards by Messrs Jessop and Telford, this sum is proposed to be expended, and the works completed, in the course of seven years from the period of their commencement.

In this stage of the affairs of a work so extensive in its operation, and so important in its consequences, it became of the last importance, in finally resolving upon the dimensions of the first lock, to fix upon such as would answer, in the fullest manner, all the purposes of the intended navigation. To this point, therefore, the attention of the Engineers was again directed; especially as the dimensions of the first lock would not only regulate all the rest, but also the works of excavation along the whole line of the canal. After maturely deliberating upon all the information which had been obtained, regarding the description and tonnage of the shipping which navigate the northern seas, and advising at large, as before noticed, with Engineers, Mariners, and Merchants, upon the important subject of the dimensions of the canal;—it having been specified in the act authorizing this work, that such an inland navigation should be formed, as, when completed,

Caledonian Canal.

First Dimensions and Estimates.

Caledonian Canal.

might "enable ships and vessels of considerable burden, trading between the eastern and western coasts of Great Britain and Ireland, and the German Ocean, to avoid a long and dangerous navigation round the northern coasts of Scotland;" the Commissioners, considering also that the proposed dimensions of the works of excavation, viz. 20 feet of depth, 50 feet of width at bottom, and 110 feet at the surface water-line of the canal, would admit and be sufficient to float a 32 gun frigate; and as only a very small addition to the original and annual expence would be incurred by enlarging the locks for that purpose;— it was finally ordered, that the length of the locks should be increased from 162 to 172 feet, and that the breadth should be from 38 to 40 feet, the depth to remain at 20 feet as before intended. The Commissioners thought it their duty to prefer this large scale of construction, as, although it would increase the expence, the canal would thereby be capable of affording an occasional passage to that class of His Majesty's ships, of which there was, at that period, upwards of forty in the service, which must otherwise have been excluded from it. In this resolution, the Board of Commissioners had also in view the increasing tonnage of merchant ships, as some of the vessels trading between Liverpool and the Baltic, approach to the dimensions even of these enlarged locks.

Side Locks. With a view to give greater facility to the passage of small vessels, and to avoid the consequent wear of the large locks, the Engineers had been directed to consider the propriety of constructing small *side-locks* for vessels of about 200 tons, which draw about twelve feet water, or of such dimensions as to correspond with the depth of the Crinan Canal. This appendage of small locks, it appeared, would have added to the original expence about L. 75,200; and considering that two, or even three small vessels might pass together through the large locks, the advantages attending the *side-locks* appeared to be very uncertain, and the idea was therefore laid aside for the present.

New Act of Parliament. It appears from the first Report of the Commissioners for making the Caledonian Canal, that the sum of L. 6052, 10s. 10½d. had been expended in the preparatory measures for this great undertaking. In the Session of Parliament 1804, another act was passed, entitled, "An Act for making further Provision for making and maintaining an Inland Navigation, commonly called The Caledonian Canal, from the eastern to the western Sea, by Inverness and Fort-William in Scotland." By this additional act, a further provision of L. 50,000 was made for this undertaking.

Commencement of the Work. In the month of June 1804, the Commissioners resolved that Mr Jessop should again visit the line of the intended navigation in concert with Mr Telford, that they might jointly inspect the progress of the works already commenced, and re-examine all the particulars of the former survey; that they might determine the position of each lock on the whole line of the canal, and, as far as possible, fix the situation, dimensions, and construction of the bridges, culverts, and other necessary works; and that they might take into consideration the manner in which

it would be most convenient to connect the line of Caledonian the canal with the several lochs or lakes forming part of the intended navigation; and also fix and arrange the price of labour, and the mode in which the several works would be most advantageously let or contracted for.

During the first year (1803), the operations were merely of a preparatory nature, and the number of workmen did not exceed 150. But in the year following they were increased to upwards of 900, when it became necessary to appoint resident Engineers, particularly at the extremities of the line, to which the first works were entirely confined. For this highly important charge, Mr Matthew Davidson, who had acquired much experience at the works upon the Elsemere Canal, particularly at the great aqueduct of Pontycyfelte in Denbighshire, was appointed to the eastern division, and Mr John Telford took charge at the western end.

In the commencement of operations of this public nature, it became an important consideration to interfere as little as possible with the rates of the stated labour of the country; and therefore, as well as from motives of economy, only about one-sixth part of the work was done by *day-labour*, the other parts being done by *contract* and *measurement*. The rates for day-labour and workmanship, as fixed by Messrs Jessop and Telford in 1804, we shall state, more as a matter of future, than of present interest. Labourers by the day, were paid from 1s. 6d. to 1s. 8d. and 2s., according to the description of work. The works of excavation and embankment varied according to the distance of removal. That for the earthen work of coffer-dams of the eastern division was 9d. *per* cubic yard, exclusively of pumping water, working the puddle in the banks, or expence of railways. The rate or price of iron-work to be 5½d. *per* lib., when the price of Swedish iron is at L. 30 *per* ton at Inverness. Timber work in coffer-dams, and sheeting to locks, 6d. *per* cubic foot for labour only. Rubble masonry, laid in lime mortar, at 11s. *per* cubic yard, cut stone or squared masonry at 1s. 7d. *per* cubic foot, exclusively of pozzolano or tarras, where necessary. In common earth cutting, including puddling and forming the banks, the price throughout the whole works was not to exceed the average rate of 6d. *per* cubic yard; excepting in cases where the removal of the puddle should exceed 100 yards, when an extra allowance was to be made by the award of Mr Thomas Telford. Also, wherever the removal of earth by barrow exceeds 60 lineal yards, or 120 yards by barrow-carts, an allowance to be made over and above these prices, at the rate of ¾d. *per* cubic yard for every *run* of 20 yards by barrow, or 40 yards by barrow-carts. The same rate of prices is applicable to the works of the western division of the canal, only in such instances as the circumstances differ materially. Part of the excavation at the western end is in rock, which is to be paid for at the rate of 2s. *per* cubic yard, and the excavation and embankment at 8d. *per* cubic yard. The most considerable difference here was in the price of cut stone, or squared masonry. At the eastern division, the quarry of Redcastle is only about five or six miles from the work; while

Caledonian Canal.

at the western division, the cut stones for hollow quoins, coping stones, &c. were brought from the Cumbrae Island in the Clyde, distant, even by the Crinan Canal, upwards of 100 miles; the price of cut stone work was consequently fixed at 2s. 5d. per cubic foot, instead of 1s. 7d.; or if granite from Ballahulish, distant about twenty miles, should be used, the price to be at the rate of 2s. per cubic foot. But even these prices were, upon due investigation, found to be insufficient, and the contractors were afterwards allowed at the rate of 3d. per cubic foot in addition for cut stone, and 1s. per cubic yard for rubble work.

These highly important arrangements being made, the masonry, and much of the work of excavation and embankment, were undertaken by contract, and proceeded with great alacrity. Men skilled in the various branches of canal work resorted to the Caledonian Canal, from all parts of the united kingdom; and no less than about one thousand men have been employed on an average for the year; so that this tract of country, lately a forlorn waste, became all at once a place of active industry. The Highlander, hitherto accustomed to loiter away his days in indolence, looked on for a time with astonishment at the exertions of his southern brethren, and ere long mixed with this busy scene. In this respect, the Caledonian Canal has been of immense advantage to the Highlanders, a fact which the writer of this article has had many opportunities to observe.

Description of the Line of the Canal.

Having thus stated the commencement of the Canal, we shall next give a general description or outline of the country through which it passes, proceeding from the east to the west sea. Mr Watt, in his Report of 1773, observes, that the regularity of this extensive tract is quite astonishing, in so mountainous and rugged a country. Mr Jessop, in his first Report, says, that at some early age of the world, it seems probable this immense chasm (the line of the Canal) has been nearly open from sea to sea. Though the investigations of the Geologist have, as yet, we may observe, made small progress in elucidating the probable revolutions which the earth has undergone; and although, upon every hand, he is met by difficulties, and contradictory appearances, yet it is scarcely possible that any one who has examined and considered the appearances of this interesting chain of salt and fresh water lochs or lakes, can doubt that, at some period of the world, the sea has occupied a higher level; that the country in the vicinity of the towns of Inverness and Fort-William have been, at one time, covered by it to a much greater extent; and that at some period the whole of this chain of lakes, thus forming one great sheet of water, had only one barrier, at the eastern, and another at the western extremity. These barriers or fences, in the course of time, being worn down, the increased issue of the waters from the original loch, would have a tendency to lower the surface of the water, and thereby expose the highest parts of the bed, and thus ultimately form the divisions or necks of land which we now find separating and dividing these lochs. So much of probability does this theory carry with it, that, along the whole length

of the line of canal, the excavated matters, with little exception, are found to consist chiefly of gravel and water-worn stones: these subdivisions, once formed and exposed to the atmosphere, would acquire vegetable and adventitious matters; and in time, by the wearing of the beds of the original outlets, these patches of land would rapidly increase.

Caledonian Canal.

But whatever may have been the actual state of matters here, at an early period, the great vale, or perhaps more properly, the chasm, of the Ness and Lochy, is, without exception, the most remarkable in the kingdom; for, in a distance of about sixty miles, from sea to sea, the summit level of this navigation is only about 94 feet above the level of the ocean. There are, indeed, some approximations to this state of things; as, for example, between Crinan and Lochgilphead,—(the line of the Crinan Canal.) This may also be noticed of various other parts of the kingdom,—as between the great Wash of Lincoln on the east, and the vale of Gloucester and Severn on the west; between the river Tyne and the Solway Firth; the Firth of Forth, by Blair Drummond Moss, and the Clyde. Perhaps the nearest to the vale of the Ness and Lochy of those mentioned, is that between the Forth and the Clyde, which passes between two ranges of hills; but all of these come far short, in sublimity of effect, to the line of the Caledonian Canal, where the hills rise to a stupendous height, while the bottom of the dell, or vale, is interspersed with extensive sheets of water.

Compared with other parts of the country.

We shall now proceed to notice the position of the first, or sea lock, of the canal at Loch Beau District. ly on the east, and so advancing westward, describe the works of this great Inland Navigation. The precise spot originally intended for the Eastern Sea or tide-lock, was rather to the north-eastward of the present site; but the ground, upon trial, was found not to answer the purposes of a foundation, for such a weight of masonry. The sea lock of Clachnaharry is about three quarters of a mile to the westward of the much frequented Ferry of Kessock. It extends upwards of 400 yards into the sea, or beyond the high water mark, where it is expected a depth of water, equal to about 30 feet, will be obtained at high water of spring-tides. The writer of this article, attracted by the magnitude and novelty of this particular operation, visited it in the autumn of 1811, when the masonry was then in a half finished state; and cannot pass this extensive and interesting part of the works, without noticing more particularly its progress and completion. The unexampled price of foreign timber, especially of large dimensions, about the year 1807, had induced the Engineers to delay commencing the sea lock as long as possible, in hopes of a change of circumstances. In 1808, however, it was thought advisable to lay down an immense quantity of rubbish, in the form of two parallel mounds, extending from the second canal lock into Beau-ly Firth. This was done by means of two sets of railways; one from the rubble stone quarry of Clachnaharry; and the other, consisting of a kind of indurated clay, was carried across the line of the canal from an adjacent hill, along the site of the intended sea lock; that it might answer the purposes of a

Caledonian
Canal.

coffer-dam, and consolidate the subsoil or strata of matters deposited from the joint operation of the River and Firth of Beaully. These strata, when bored to the depth of about 54 feet, were found to consist of soft bluish clay or mud, overlying a whitish clay, similar to the base of the neighbouring hill of Clachnaharry. These mounds of rubbish extending into the sea, were found to settle and subside so much, as to require an additional stratum of 11 feet in thickness to restore them to their former level; an effect which was, no doubt, expected; but this, however, was the means of suggesting the propriety of laying also a quantity of rubbish between these mounds or parallel banks upon the site of the sea lock, which, in the same manner, had the effect of compressing the subsoil, and preparing it for the immense weight of masonry it had to support, which could not have been the case, had it been built with a coffer-dam in the usual way: the finished work might, in that case, have subsided in the same manner as the mounds had done, which would have been productive of the most serious consequences to the work. This consideration, in conjunction with the high price of timber, induced Messrs Jessop and Telford to adopt the simple but more secure method just described; and when the mass of rubbish had sufficiently subsided, they commenced their operations by excavating the lock-pit in the mound of rubbish lying upon the site of the lock to the depth of about 30 feet, when the subsoil was found in such a state of consolidation, that the excavation had proceeded to a considerable depth before it was found necessary to have recourse to the power of steam, for pumping the water out of the lock-pit. It has indeed been remarked of the adhesive nature of this ground, that although piles were driven with great ease into it, yet, after they had remained for a time in the silt, it was neither found practicable to draw them out, nor to drive them farther into the ground. When the area of the lock-pit had been dug to a sufficient depth, a course of large stones, two feet in thickness, was laid in the middle for supporting the key-stone of the inverted arch of the lock. This foundation course increased in thickness to five feet towards the springing in front of the side walls, which were built upon it with all possible dispatch, in lengths or compartments of six yards at a time, till the whole was brought to the height of the silt, or to about eight feet, that it might not be unduly exposed to *wet and dry*. In this manner the work proceeded, till the chamber of the lock was formed by the side walls, when the inverted arch and sides of squared masonry was built upon this layer of rubble work, which finished the work. The construction of this lock is particularly noticed in the Parliamentary Reports with marks of approbation to all concerned; and, with much propriety, the Commissioners have there been pleased to notice the successful exertions of Mr Davidson, the Resident Engineer.

Clachnaharry Lock
and Basin.

Having thus given a general description of this tide-lock, which has a lift or rise eight feet six inches, and is, perhaps, the most extraordinary work upon the whole line of this navigation, or, indeed, in any part of the kingdom; proceeding eastwards, we come

to the second, or Clachnaharry lock, which is contiguous to the sea-lock, being itself barely within the high water mark. It is close to the small fishing village of Clachnaharry, which, prior to the commencement of these works, consisted of six or eight fishermen's huts. It has still but a few additional houses, yet when this navigation is fully opened, it may rapidly increase, and in time become the port of Inverness, and a place of considerable trade. Clachnaharry lock has a perpendicular rise of six feet, and forms a division between the sea-lock-basin, and the great basin of Muirton, containing an area of about twenty acres. This great basin is of an oblong, and rather irregular form, but is well suited to the figure of the ground; it is formed by works of excavation and embankment, and has a wharf wall of considerable extent, which will be convenient for the town of Inverness, from which it is distant only about one mile. To defend the projecting mounds upon each side of the sea-lock, rubble stones are laid upon the external slopes with such a gentle declivity to the sea, as to be sufficiently secure against the impression of the waves of the Beaully Firth, while the exterior bank of the Muirton basin is defended from its encroachment, by a dike of considerable extent.

At the southern extremity of this basin, the ^{Swivel} road from Inverness to Beaully crosses the line of ^{Bridges} the canal; and here a handsome Turn or Swivel Bridge of cast-iron, on a very light construction, has been erected upon piers of masonry. Canal bridges were formerly constructed of timber, and lifted in two leaves or halves by chains and a large timber framing; but they are now chiefly framed of cast-iron, the roadway only being covered with timber; and by the latest improvements they are raised by a wheel and pinion, as originally projected by Mr Peronnet for the Neva, at St Petersburg, and now introduced on the Forth and Clyde Canal; or as here managed, they are made to turn in two pieces, each placed upon an opposite abutment of masonry, and move upon a centre, similar to those of the West India and London Docks. The compartments which project over the water way of the canal, meet and joggle into each other, while the opposite ends, towards the land, are loaded so as to balance and become a counterpoise to the projecting parts. When a vessel is to pass, the two parts of the bridge are disengaged, and turned off the line of the canal in a horizontal position, by a person stationed on each side of the canal, who works it with a kind of key-bar with a cross head. This key is made to fit the pinion, which works in the segment of a wheel several feet in radius, and is thus easily turned out of the way of the rigging of passing vessels.

The Muirton locks are four in number, and have ^{Muirton} each a rise of eight feet. The foundations of these ^{Locks} locks were upon the whole easy, being upon a bottom of hard whitish clay, mixed with gravel; by building them in one connected range, it was necessary to lengthen each a few feet, to give accommodation to the largest vessels; but still a considerable saving is introduced by this method, as the head and tail walls, and also one pair of gates, are saved. These locks, when viewed from the bridge below, and especially when the gates are open, present a very noble

Caledonian Canal.

Caledonian Canal.

appearance, and seem to be upon the whole an excellent piece of masonry. The gates or valves consist of British oak for the lower and upper gates, being more liable to accident of ships coming against them than any of the intermediate ones, which are framed of cast-iron in great bars, covered over with strong oak planks, attached to the cast-iron work by numerous screw bolts with nuts. Lock-gates of cast-iron have been for a considerable time in use. Perhaps the first of these were constructed on Carron River, upon a small dock for the repair of the Carron Company's ships; but they are very trifling compared with the great dimensions of the Caledonian Canal-gates, which measure 30 feet in height, and each leaf is 22 feet in breadth. Cast-iron gates, however, seem to have been brought into use here, rather as a matter of necessity than of choice, from the difficulty and expence of procuring oak of sufficient scantling or size. The lock-gates have a very stupendous appearance, yet are moved with comparative ease, by means of chains with a wheel and pinion upon the most approved principles. The *heel* of the gate, or that part which works in the hollow quins, is placed upon a pivot, and the *toe*, or outward extremity, is fitted with a roller connected with a screw-bar, in such a manner that the roller may be raised or lowered to suit the ground-sill of the lock, where a segment of cast-iron is inlaid, on which the roller and gate traverse, in opening and shutting; so that these stupendous gates, weighing about 40 tons, are opened and shut with great facility, by one man on each side of the lock.

Masonry of the Locks.

The masonry of the sea lock is executed wholly of freestone or sandstone, from Redcastle quarry; but the second, or Clachnaharry lock, and also the four locks at Muirton, and the abutments of the Muirton and Bught Bridges, are only faced with Redcastle stone, the inward walls or backing being rubble stone, from the more contiguous quarry of Clachnaharry.

It deserves to be noticed, in this place, that the whole of the face-walls of the masonry here were only specified and paid for as common rubble work, instead of which, with few exceptions, the work is executed of a superior quality, in regular courses, technically called *coursed rubble*. This certainly does much credit to the spirit in which the contractors for this great undertaking seem to have conducted their operations; and it is but justice here to notice the name of a person who, for many years, was eminent as a contractor for masonry, especially for canal works, harbours, and bridges, throughout the kingdom—we mean the late Mr Simpson of Shrewsbury, principal contractor upon the Caledonian Canal,—a native of Scotland; and who, it is believed, has superintended and executed more work of this kind than perhaps any other individual in the line of his profession.

Expence of Locks.

It is not always possible to apportion the expence of the several compartments of a large work, so as to show the neat cost of each, but it seems probable that these locks, upon an average, exclusively of the sea lock, will have cost, when entirely finished, not less than L.8000. This sum, compared with other works also of considerable magnitude, appears to be very moderately stated, although it is somewhat higher than the estimates of 1804, and considerably

more than had been originally calculated upon in 1802. Besides the difference of time between the estimates and the execution of the work, the unexampled rise in the price of labour, and indeed of every commodity. The estimate of 1802 applied to locks of a very different construction from those actually executed. The locks originally proposed by Mr Telford would, no doubt, have been considerably less expensive, probably not exceeding L. 5000, as they were only meant to have had masonry at the gates, while the space between was to be embanked, like the other parts of the canal. But as this would have made the navigation much more tedious, it was determined to line the lock-chambers with masonry, in the usual way, when the locks were then estimated, each, at L. 7500; so that this part of the work may fairly be considered as not greatly exceeding the estimate.

On the Reach of the canal between Muirton locks and Loch Ness, the distance is about five miles. The works of excavation here are chiefly in gravel, some parts of a loose and others of a more compact nature; and containing various proportions of earthy matters. But, upon the whole, the soil is exceedingly bad for canal work; which renders it necessary to trust a great deal to the puddle-walls of the banks and bottom, against the pressure of the great depth of water in this canal. On this reach there is some deep cutting, in passing the singular hillock of Tomnahurich; and the road on the eastern side of Torvaine hill, has been carried by a new line on the western side. A considerable embankment also became necessary to the westward of the lands of Bught, where the eastern bank of the canal is actually formed on the bed of the river Ness, under the hill of Torvaine. Here the course of the river has to be altered and widened by cutting away part of its eastern bank, for the space of about half a mile. A similar operation, but of smaller extent, became necessary under the hill of Toremore, where the canal banks again trench upon the river Ness; after which, the only work of expence on this reach, is the construction of a regulating-lock and weir for the waters of Loch Ness.

Reach from Muirton to Loch Doughfour.

It was, no doubt, a bold attempt, to place the bank of a canal upon the verge of a considerable river, but after a trial of several years, it has sustained no material injury. This arises entirely from the waters being, in a good measure, regulated and apportioned by the great receptacle of Loch Ness, which so regulates the stream of that river, and checks its velocity, as to prevent the injurious effects that would, under other circumstances, attend the exposed state of the canal banks at this place, however well armed and secured by a facing of boulder or rubble stones, upon the slope of the outward bank.

The Regulating-lock for Lochs Doughfour and Ness has a rise of six feet six inches, and is situated about half a mile northward from the former, which connects with Loch Ness by the narrow channel of Bona Ferry. This lock was intended to have been placed somewhat nearer the loch, and was proposed to be carried across the stream of the river Ness; but a proper foundation could not be found for it there. The close connection of its site with the river, has necessarily increased the difficulties of this part of

Caledonian Canal.

the canal, while the operations were unavoidably retarded by the land-carriage of the Redcastle stone, for the outward walls, brought over land from Clachnaharry, a distance of about six miles. Great labour and perseverance were exerted here, in clearing the lock-pit of water, to the depth of about 20 feet under the level of the bed of the river. This work commenced in July 1812, and the masonry was completed in about two years, without the occurrence of any material accident. The name of Regulating-Locks sufficiently implies its use. Connected as the canal is at this end with Lochs Doughfour and Ness, which extend about twenty-four miles to the south-westward, through a range of mountains, and, consequently, forming the drainage of a great extent of country, it is obvious that these extensive lochs must receive vast quantities of water during wet and rainy seasons, but especially in time of thaw, when there is much snow upon the ground. The effect must be, to raise the surface of the water of Loch Ness, which has been known, on such occasions, to rise from six to eight feet above its ordinary summer level. Indeed, the remarkable regularity of the gravel beach round its margin,—the present position of many aged alder trees, even within the summer water-mark along the shores, sufficiently indicate this, and lead us to suppose, that the surface waters of the loch are, upon the whole, in a state of increase. At all events, we are certain, that the water of these lochs must have a tendency to rise, from the great quantity of debris which is constantly falling in and silting up the bottom, while the surface to be drained, and the quantity of water flowing into it, remains nearly a constant quantity. This process is, therefore, likely to keep pace with the wearing away of the bed or channel of the river, by which the flood or spout waters are let off; considerations which, of course, form the limits of the regulating lock and weir across the River Ness, connected with this chain of lochs.

Operation of deepening Loch Doughfour.

One of the most difficult operations in forming this navigation, is the deepening of Loch Doughfour. This Loch, as will be observed from the map, is connected with the eastern end of Loch Ness by the narrow pass of Bona Ferry. It is about one mile in length, and varies from 100 to 150 fathoms in breadth. From the rapid current at Bona Ferry, it appears that the fall of the water, towards the river and the sea, commences here, and with Loch Doughfour forms a receptacle for much of the gravel and debris, which is brought down from the extensive shores of Loch Ness. This part of the navigation it was therefore found necessary to deepen, by artificial means, in some places, to nearly the full depth of the canal. This was done partly by a powerful dredging-machine, which is floated upon a barge. The apparatus is somewhat complicated, but the chief part is a succession of iron buckets, connected by an endless chain made to revolve round a frame, which is let down into the water to any convenient depth, and lifts silt, gravel, and other matters from the bottom. This machine has been long in use in clearing mud from the bottom of harbours and rivers. Till of late years it was worked by the power of men and horses, but where much is to be done, as on the Caledonian Canal, the steam-engine is substituted as the moving power;

which requires a barge or vessel of great strength to carry it. The dredging-machine has been used with much success at Loch Doughfour, where it is calculated to have lifted about 90,000 tons of gravel in a twelvemonth. The stuff lifted is received from the dredging-machine, as it comes out of the water, in punts or lighters, and is carried to a proper place for deposition. By such means, the navigation from the eastern end of Loch Doughfour to Loch Ness is brought to a depth no where less than ten feet. In the course of this arduous operation, the roots of large trees have been lifted, weighing several tons. Even rock has been excavated at this depth under water, by means of placing picks instead of buckets upon the revolving apparatus.

To obtain the additional depth of water, beyond the reach of the dredging-machine, a weir or dam is to be placed across the eastern end of Loch Doughfour, where the river Ness properly commences. This dam or weir will not only deepen the loch, but will check the current at Bona Ferry, and prevent the tendency of the debris from being carried from Loch Ness into Loch Doughfour. The waters of the Ness will then be drawn off from the surface of the loch, and will cease to carry with it quantities of stones and gravel, as at present, and Loch Doughfour will become an excellent place of anchorage for wind-bound ships. The operation of building this dam or weir across the Ness, has not yet been commenced. It will be attended with considerable difficulty from the current of the river, and from the requisite strength and important purposes to be served by it.

Loch Ness, forming so considerable a part of this navigation, is about twenty-two miles in length, of a pretty uniform breadth, varying from about one mile to three quarters of a mile. Its depth of water is from 106 to 180 fathoms in the middle or deepest parts. The sides of the loch appear to be steep and precipitous, as it suddenly deepens to 70 and 80 fathoms; except in the creeks or bays of Dores, Urquhart, Inver Morrison, Cherry Island, and the western extremity of the loch. The depth of water in these varies from 12 to 20 fathoms; but even these soundings are so close to the shore, that it has been suggested to lay Mooring-Buoys to enable ships to stop for a time; as it would be quite unsafe, especially for ships of great tonnage, to let go an anchor, chiefly from the difficulty of purchasing or lifting it. Indeed the necessity of this in these lochs is in a great measure superseded, by the proposed use of the steam-boat for tracking ships; and the anchorage or mooring buoys for large vessels may now be confined almost entirely to the east and west ends of the loch; as the distance to return to either end, in the event of such weather as may prevent the steam tracker from proceeding, cannot be a matter of much moment. The application of steam as a power for impelling ships, is a discovery of the greatest importance to the speedy navigation of the Caledonian Canal. Upon the formed banks a tracking-path is readily obtained, but along the precipitous shores and cliffs of the lochs, this would not be so easy a matter; and, even if formed, would not be conveniently brought into use for tracking ships of burden. For although vessels of about 200 or even 300 tons, might tack or work in Loch

Caledonian Canal. Ness and Loch Lochy, yet even for these it would be an extremely troublesome operation; and altogether impracticable in the case of ships of war, or the largest class of merchant vessels.

Effect of the Winds upon this navigation. There has been much discussion respecting the sailing of ships on the loch part of this navigation. It had been asserted, that the winds blow almost constantly in a current from the south-west so as to render it difficult, if not impossible, to pass by this navigation from the eastern to the western sea. But, upon a more minute attention to the subject, from the returns or register of the winds, and state of the weather, by the barometer and thermometer, kept at Clachnaharry, Fort-Augustus, and Fort-William, by order of the Commissioners, since the year 1804 up to the last return of 1816, it appears, that the winds are nearly as subject to change in the great vale between Inverness and Fort-William, as in other parts of the country.

Middle District. In the Parliamentary Reports, the Caledonian Canal is generally laid out in three districts, viz. the Clachnaharry or eastern district, comprehending the works from Loch Beaully to Fort-Augustus; the middle district, extending to the west end of Loch Lochy; and the Corpach or western district, from Loch Lochy to Loch Eil, or the western sea. With regard to the middle district, we observe that hitherto the sum annually allowed for this work does not admit of every part being carried on with equal vigour. The works of this compartment have, therefore, been almost wholly confined to excavating the ground; it being of importance to have the eastern end opened to Loch Ness, and the western division to Loch Lochy, before much was done to the masonry of the central parts; in order to facilitate the transport of materials from the respective seas. This may now be confidently expected to be accomplished, at least for vessels drawing eight or ten feet water, in the course of the current year, 1817.

Locks. The extent of the navigation comprehended in the middle district is about twelve miles. The whole height, from the Beaully Firth or the east sea to Loch Oich, the summit level of the canal, is stated at about 94 feet; and as 53 feet of this has been overcome in rising to Loch Ness, it appears that about 41 feet will form the rise of the lockage of the middle district; while the fall on the western side to Loch Eil is only 90 feet. This is to be overcome by a chain of four locks at Fort-Augustus, and one at Callachie, near three miles westward, independently of the Regulating-lock within half a mile of Loch Oich. The foundation of the chain of locks at Fort-Augustus has been long a matter of uncertainty; and when the writer of this article visited the works, in the month of August 1816, though preparations had been made by changing a part of the course of the river Oich, and a steam-engine of 36 horses' power was then erected for clearing the lock-pits of water; yet the foundation of the lowest lock was nevertheless looked forward to with anxiety, from the loose nature of the gravel, and the quantity of water which continued to flow into the excavated part. But the official gentlemen of this establishment are so much accustomed to encounter difficulties, that they had other expedients in reserve, in case of any

failure attending the plan then in hand. The lock at Callachie is curiously situated, being founded and built upon a dike or stratum of rock called *Grey Wacke* by Mineralogists, which runs across the moor, and is indeed the only piece of rock on this part of the line of the canal. It is just large enough for the site of the lock, and was preferred to gravel as a foundation. This rock being found very compact, it rendered an inverted arch for the lock unnecessary.

Considerable progress has been made upon the middle district in excavation, which, with little exception, is in gravel. The greater part of the canal is now formed, and cut to the requisite depth. For the purpose of deepening Loch Oich (on which is situated the famous castle of Glengary, the seat of the Macdonnells), a dredging machine of great power is to be employed, which is to have four punts or lighters attached to it. This will form a difficult part of the works of the middle district; but the experience and practice acquired upon Loch Dough-four will prove of much advantage to the operations upon Loch Oich.

The track of the canal is here so close upon the Loch and river Oich, that the course of that river requires to be altered in two or three instances. Nor is this river quite so manageable as the Ness; owing to the smaller capacity of Loch Oich, and its connection with Loch Gary, it forms the drainage of a great extent of mountainous country, without having any very considerable space for containing its flood waters, like that of Loch Ness; for the waters of the river Ness cannot be swelled till the whole surface of Loch Ness is raised. We are therefore to look upon the river Oich, in so far as it interferes with the track of the canal, as much more troublesome, and requiring a different management.

The western or Corpach district of the Caledonian Canal, may, in a great measure, be supposed to resemble the eastern or Clachnaharry district in its general outline and operations, making a due allowance for the difference of situation and local circumstances.

On the Clachnaharry or eastern division of the canal, we have endeavoured to give some account of the principal works as they occur. To go again into detail, would only be to repeat, in some measure, what is already sufficiently noticed for the general reader. Those who wish to be more critically informed, would do well to look into the Parliamentary Reports; and we think a visit to this great national work, quite as necessary to the traveller, as the Languedock Canal is considered by many who visit France; while the mountainous tract through which this navigation passes, is likely to be far more interesting to the Mineralogist, and to those who seek after and admire the bold scenery of a country, almost completely in a state of nature.

The first great work upon the western district is the raising the surface of Loch Lochy about twelve feet perpendicular; which is effected by shutting up the present course, and excavating a new channel for the river Lochy, the only stream that flows from the loch, raising the level of its new alveus or bed, and thereby rendering the works of the summit level more easy than by works of excavation. By this means, the new course of the river Lochy, about

Caledonian
Canal.

half a mile in length, cut through a piece of flat ground, called Mucomer, forms its confluence with the river Spean, nearly half a mile further up that river. The joint waters of the Lochy and the Spean soon afterwards skirt the eastern bank of the canal, where it becomes necessary to make a strong defence against their joint effects, by arming and fortifying it with rubble stone.

From Loch Lochy to Loch Eil, the distance is about eight miles, on which the canal works may now be considered as very nearly finished, having kept pace with those of the eastern district; so that there is little doubt that this end will also be opened for the purposes of the work in the course of the year 1817. The works of this compartment, both in regard to masonry, excavation, and embankment, have been more expensive than those of the eastern division; in particular, the deep cutting at Moy, Strone, and Muirshearlich, and excavating the sites of the locks and basin for shipping at Corpach in rock. But, perhaps, if all the expence of the foundations and earth work on the Beaully Firth are taken into account, they may be found to have been as expensive, if not more so, than the blasting of rocks on the Corpach district.

Aqueducts.

The aqueducts and masonry in general of this district are executed in rubble work, excepting the principal stones of the lock-work, which are of sandstone from the Clyde. In the regulating lock of Loch Lochy, the hollow quoins, from the difficulties attending the land-carriage, are actually constructed of cast-iron, being a new application of that British manufacture in massive building. Over the Mucomer channel of the river Lochy, a very handsome stone-bridge of two arches of fifty feet each has been erected. From the irregularity of the ground on this part of the track of the canal, which is much cut up with mountain brooks, a number of aqueducts have been found necessary; one, in particular, over the Loy, consists of a centre arch of 20 feet span, and two side arches of 10 feet each, and, owing to the width of embankment here, the arch is no less than 250 feet in length. But in this and other cases the side arches answer the purpose of passages under the canal, and thus save the expence of bridges. Another very difficult and troublesome part of the navigation, occurs at East Moy, where like that of Doughfour Burn, on the eastern division, the water is allowed to flow into the canal, but the gravel and stones are intercepted, by a kind of cess-pool, formed in the adjoining valley.

Great Chain
of Locks.

In our progress towards the western sea-lock of Loch Eil, after passing the aqueduct of the Lower Banavie burn, we reach the famous chain or suite consisting of EIGHT LOCKS, not unaptly termed "NEPTUNE'S STAIRCASE" by the artificers and workmen. This majestic chain of locks was finished, excepting the gates, in 1811. The probable cost of these locks may be stated at about L. 50,000. They occupy a range of 500 yards, and rise altogether about 60 feet perpendicular. The common void or cavity of the lock-chambers is 40 feet in width, and the depth 20 feet; the bottom, forming an inverted arch, gives the whole a very grand appearance, presenting the greatest mass of masonry any where to be found as applicable to the purposes of a canal. After pass-

ing this interesting part of the work, the canal gets easily along Corpach Moss (to the House of Corpach, the former seat of the Camerons of Loch-eil). Here a double lock is situate, connected with a basin for shipping, measuring 250 yards in length by 100 yards in breadth, which joins the sea-lock, and so communicates with the Western Ocean by two mounds projecting about 350 yards into Loch Eil, and completing the inland navigation of the Caledonian Canal from sea to sea.

As before noticed, the operations of the canal have been hitherto chiefly confined to the eastern and western divisions, so as to render these subservient to the operations of the middle or central division. The artificers have now been employed to a greater or less extent upon the middle part for two seasons, and the probability is, that the canal may be opened from sea to sea in about three years, or in 1820. But, in works of this kind, it is almost impossible to foresee every contingency, and much depends upon the annual extent of funds to be laid out, and the effect which may thereby be given to the works. Time must also be allowed for proving the banks, and puddle-walls, which, in all similar works, are found to leak in the first instance, and require the banks to be partially opened.

The expence of this great work, up to the month of April 1816, by the Parliamentary Reports, appears to amount to about L. 600,000; and, in all probability, before it is opened from sea to sea, it will require the expenditure of L. 200,000 more, or L. 800,000 in whole; independently of the expence of the various improvements to be made for the navigation, which experience alone can point out and determine, after the canal is opened.

To render the access from seaward to the canal more safe, and give every facility to the navigation, there will require to be beacons fixed, and buoys moored in various parts, and even a light-house erected at Tarbetness, in the Murray Firth, and another, as a direction for the Sound, between the Islands of Mull and Kerrara. Nor will the full advantages of this navigation be felt, until west Loch Eil is connected with Loch Shiel, and a passage found to the Western Ocean, in the direction of the districts of Ardnarrachan and Moidart.

The question of the ultimate advantage of this work, has been matter of much discussion. But, we believe, this may, at once, be restricted to the consideration of the propriety of the excess of dimensions above the depth of fifteen or sixteen feet, so as to admit almost the largest class of merchant ships, using the Baltic and North Sea trade. Now, we think it was proper that it should be constructed upon a scale calculated to meet the increasing dimensions of merchant vessels. For when the Forth and Clyde Canal was determined, in the year 1768, to be of the depth of eight feet, and the locks in proportion to measure seventy-four feet in length, and nineteen feet in breadth, it was termed the "GREAT CANAL," and it is worthy of remark that its uncommon size, for that day, was considered unnecessary and useless for the trade of the country. The reverse of all this, however, has been found by

folding may **Calender.**
erwards be
 ing of it to

calendering
 or threads
 in some de-
 pe, and re-
 , by bring-
 each other,
 of closeness
 ssess. The
 es the su-
 a all knots,
 ch no mate-
 an ever be
 ses of spin-

irable, and
 and beauty
 should re-
 plication of
 sh, which is
 of glazing,
 ich are em-
 male attire.
 sole and ex-
 al operation
 ons besides
 the proper
 ese also are
 e same pre-
 not strictly
 he term ca-
 hief mecha-
 name to the
 t operations
 as usual to
 s are *dress-*
 herefore, of
 s article will
 y a distinct
 d operation
 and then to
 ervations as
 ss of cloth-
 ded form.
 urfaces of a
 y should be
 re in every
 y to acquire
 lish. Such
 roduce this
 large plane
 lers, in this
 respects in-
 both in the
 he common
 mple of all
 application
 d be difficult
 ntly level to
 ct with the
 ew folds of
 ollen cloth.
 erseded, ma-

Caledonian Canal.

half a mile ground, cal the river Sp river. The soon afterw where it bec against their it with ruble

From Loc eight miles, considered with those of little doubt purposes of The works of masonry, es more expen in particular Muirshearlic and basin fo haps, if all t work on the they may b not more so pach district

Aqueducts.

The aque trict are exe cipal stones from the Cl Lochy, the tending the of cast-iron, manufacture mer channe stone-bridge been erected on this part cut up with have been f the Loy, co and two side the width of than 250 feet the side arcl der the cana Another ver navigation, Doughfour is allowed to stones are in ed in the ad

Great Chain of Locks.

In our pr Loch Eil, at Banavie burz sisting of EX TUNE'S STA This majesti the gates, in may be state range of 500 perpendicular lock-chambe 20 feet; the the whole a greatest ma applicable to

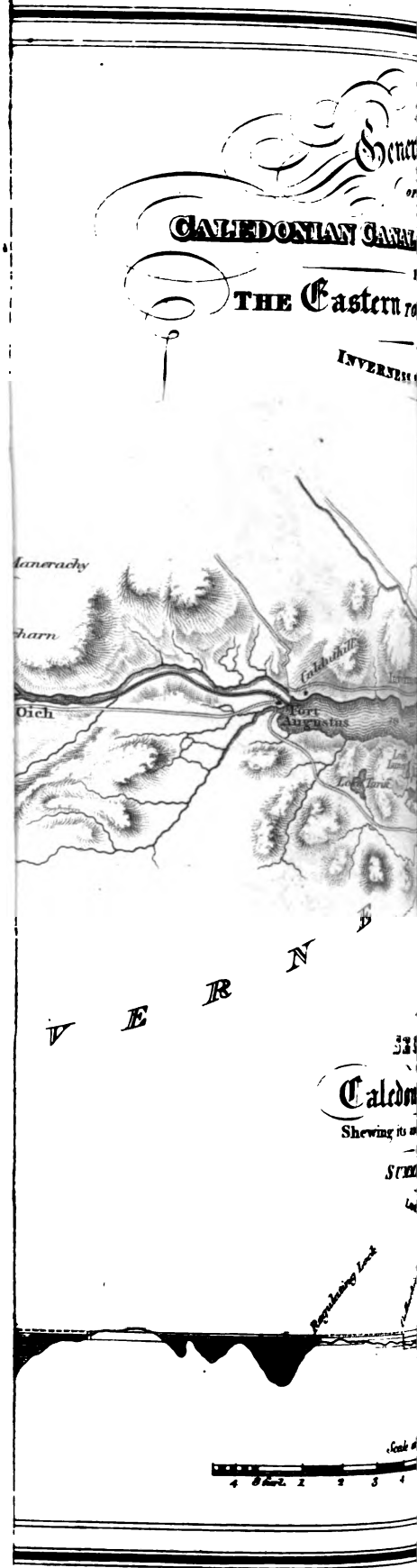

Caledonian Canal Calender. experience; and if its dimensions could now be enlarged and its depth increased to the rise of the tides of the Firth of Forth, or to the depth of sixteen feet, the benefit of that navigation to the country would be incalculably greater. The Commissioners for the Caledonian Canal certainly acted wisely, in keeping its dimensions large; as this will be of great service in navigating vessels even of a middling size; the force applicable to the trackage of ships being found to be in proportion to the quantity of the fluid compared to the bulk of the vessel. Although the inducement for frigates and the smaller classes of his Majesty's ships of war passing through this navigation, does not appear very obvious, yet cases may occur when this may be found advisable; and as there is an abundant supply of water from the lochs upon this line of canal for the wants of any supposable lockage, it was certainly proper, in a national work, that such an event should be provided for.

The writer of this article has made frequent voyages from the Firth of Forth to the Firth of Clyde by the Orkneys, and is well acquainted with all the tracks of that navigation; and can easily imagine its dangers, in long winter nights, even with all the advantages of light-houses and accurate surveys of the coast. He has also repeatedly visited the works of the Caledonian Canal. With regard to the quality of the workmanship, he shall only mention, as a pretty conclusive circumstance with regard to the masonry, that, from end to end of this great work, he has not seen a single *set* or *shake* in the whole of the locks and walls. Upon the subject of the navigation of a ship in the lochs or lakes, he cannot speak professionally; but, upon one of these visits, he went over the whole line in company with a captain of the Royal Navy; and although this officer did not much relish the idea of his ship putting about or tacking with *eddy winds* in these *narrows*, nor of being *dragged* along by the power of horses or of steam, yet he had no doubt as to the fitness of the navigation for smaller vessels. Indeed, since the discovery of the application of the *Dalswinton steam dragger*, the practicability of this navigation, from Fort George on the east coast, to the Ferry of Curran, at the junction of Loch Eil and Loch Linnhe on the west coast, is reduced to a certainty, for all vessels which can pass the canal locks. And thus, we have the firmest conviction, that the Caledonian Canal will, in the end, be universally viewed, as a truly great and noble undertaking, issuing in the most solid benefits to the country. (H.H.)

CALENDER, a mechanical engine employed by cloth-lappers, for dressing and finishing cloths and stuffs of various descriptions and fabrics, before exposure to sale, or delivery to purchasers. It is also used by calico-printers, in order to extend and smooth the surface of their cloths, after they have been bleached, and before they are subjected to the operations of the printing table or copperplate press.

In all cases two, and in many three, requisites must be attained, in order to give to cloth that appearance which it is deemed necessary that it should possess, to attract the eye and gratify the fancy of the purchaser and consumer,

The first of these requisites consists in as perfect extension and smoothness of surface as can be at-

tained; so that no wrinkle or doubled folding may remain in it, excepting such as shall afterwards be intentionally made, in order to the reducing of it to the proper form and shape.

The second requisite acquired by the calendering of cloth, is the compression of the yarn or threads of which the texture is composed, which in some degree divests them of their cylindrical shape, and reduces them to a degree of flatness, which, by bringing them more closely into contact with each other, gives to the fabric a greater appearance of closeness and strength, than it would otherwise possess. The operation of the calender also improves the superficial appearance, by flattening down all knots, lumps, and other imperfections, from which no material, from which cloth is fabricated, can ever be entirely freed during the previous processes of spinning and weaving.

And thirdly, in many fabrics it is desirable; and esteemed a great addition to the effect and beauty of the superficial appearance, that cloth should receive, by means of friction and an application of bleached wax, an additional lustre or polish, which is generally distinguished by the appellation of glazing, and is chiefly required in those stuffs which are employed in the ornamental descriptions of female attire.

Such, in a strictly limited sense, are the sole and exclusive effects resulting from the mechanical operation of the calender; but, as other operations besides smoothing or glazing are necessary for the proper preparation of cloths for the market, these also are carried on by the same persons and in the same premises. Hence by a natural, although not strictly correct, extension of its acceptance, the term calender, which really means only the chief mechanical engine employed, gives the general name to the whole establishment where all the varied operations of cloth-lapping are carried on; and it is as usual to say that goods are *packed*, as that goods are *dressed*, at a calender. In the illustration, therefore, of those operations, which the limits of this article will admit, the first object will be to convey a distinct idea of the principles, construction, and operation of the principal machinery employed; and then to add such general and miscellaneous observations as may serve to elucidate how the business of cloth-lapping is carried on in its present extended form.

For the purpose of smoothing both surfaces of a piece of cloth, it is necessary that they should be exposed to universal contact and pressure in every point, with some body of sufficient density to acquire the requisite degree of superficial polish. Such equality of surface, however, as will produce this effect, is not very easily attainable in large plane surfaces. Hence the contact of cylinders, in this operation, has been found to be in all respects infinitely preferable to that of planes, both in the speed and the effect of the operation. The common domestic smoothing iron is the most simple of all calendering utensils; but, even in the application of its small and limited surface, it would be difficult to procure any table or board sufficiently level to bring the whole cloth into equal contact with the iron, without the intervention of a few folds of blanket, or some other thick and soft woollen cloth.

The old, and now almost entirely superseded, ma-

Calender.

of the
calender.

Calender.
Different
kinds of
Calenders.

chine, termed a *wangle*, gives the most simple and rude approximation towards cylindrical calendering, and the substitution of circular for plane surfaces. Its operation is that of a cylinder applied to a plane, upon which it is rolled backward and forward, until some degree of smoothness is produced by this reciprocating motion. It is, therefore, very analogous in principle to the common gardener's roller, with which land is resmoothed after having been dug up for sowing or other agricultural purposes.

The smoothing calender completes the substitution of cylindrical for plane surfaces, all the parts which operate upon the cloth being of that form. This ingenious engine, which was introduced into Britain from Flanders and Holland, during the persecution of the Hugonots, has, since its introduction and adoption here, undergone no very material or important alteration or improvement in point of theoretical principle; nor, until the extension of the cotton manufacture had introduced a general spirit of mechanical improvement, had it received any great amelioration in practical execution. Two very important improvements have, however, since that period, been introduced and adopted. The first of these, which originated in Lancashire, is now almost universally employed. The second, which was invented at Glasgow, is still limited to the original proprietors or their assigns by the operation of a patent, the period of which, however, has now nearly determined.

The scope of the former of these improvements consists in the substitution of pasteboard, in the place of wood, in constructing three out of the five cylinders of which the engine is composed. These cylinders, when previously composed of wood, were found to be liable to two serious and important objections. Calenders employed in general business are necessarily subjected to frequent alternations and vicissitudes of heat and cold. These are entirely unavoidable, because, in smoothing or dressing cloths of the denser fabrics, the effect, as in the common operation of ironing linens, is found to be greatly heightened by the application of as great a degree of heat as can safely be communicated without danger to the fabrics which are to be smoothed.

The expansion of every thread which composes a given extent of cloth, although individually indistinguishable, even with microscopic aid, produces very considerable general effect, when exerted upon eight or ten thousand of these minute cylindrical substances, all combined together, in the space of one single square yard. In this expanded state, the pressure of the calender divests them more easily of their cylindrical form, and flattens them down until they come more closely into contact than before. This effect, which is in exact unison with the general theories of expansion and contraction, will at once produce an apparent increase of closeness and density to the texture, as well as of gloss to the surfaces; although the former is in fact deceptive, as no real acquisition of strength to the fabric can thus be obtained. The apparent density of fabric, as well as a higher accession of gloss, are also frequently obtained by impregnating and stiffening the cloth, after it has been bleached, with a mucilage of starch;

and this is too frequently carried to a very unfair height for the purposes of deception, which is not very easily detected, until the cloth be again exposed to moisture, when the delusive appearance instantly vanishes. Hence, in all dense fabrics, the calender is generally used in a heated state, whilst in flimsy fabrics, in which transparency of appearance is more the requisite than strength, the operation is conducted with the calender perfectly cold.

The effect of these frequent and sudden transitions upon wooden cylinders was necessarily productive both of *fissure* and *warping* or *twisting* ; and no care in drying or seasoning the wood before turning could entirely remove these defects. The substitution of pasteboard, however, afforded a radical cure for both, as well as a collateral advantage arising from its being susceptible of a much higher degree of superficial polish, which is always transferred to the cloth.

The paper or pasteboard cylinder, besides total exemption from all defects incidental to ligneous substances, from the immense density of which it is susceptible, by compression, presents a superficies capable of receiving and retaining an almost unparalleled smoothness and polish.

In order to construct cylinders of this description, an axis of malleable iron, and two circular plates of cast-iron, are, in the first place, provided. In these plates, which must be at least from one to two inches thick, there are six equidistant perforations near to the circumference, each capable of admitting a rod of malleable iron at least three-fourths of an inch in diameter. The entire space between the two iron-plates is then to be filled with circular pieces of the strongest pasteboard, exceeding, by about one inch in diameter, the iron-plates, and having each a correspondent perforation, through which the six iron rods may pass parallel to the axis. A cylinder is thus formed, the substance of which is of pasteboard locked together by plates of iron at the extremities, and susceptible, by means of screws on the extremities of the six connecting rods, of immense compression.—After undergoing this preparation, the cylinder is exposed to strong heat in a confined apartment; and, as the pasteboard daily contracts, the screws are every day tightened for the space of some weeks. The density of the cylinder is thus increased, whilst it is contracted in length upon the axis, for which contraction adequate allowance must be made in its original measure, and the operation is continued until it has gradually acquired the requisite compression. It is then re-exposed to the ordinary temperature of the atmosphere, and by its re-expansion presents a body almost inconceivably compact, its specific gravity in this state being greater than even that of silver.—The only operation now required is that of turning its superficies until correctly cylindrical; and this is a work of immense labour and patience.

The rotatory motion in turning does not exceed 40 or 50 revolutions per minute; and the turner requires two or three assistants constantly employed in sharpening his tools. When properly finished and smoothed, a pasteboard cylinder, however, apply compenates, by its strength, its gloss, and its dur-

Calender. bility, for the great labour and expence which its construction has created.

A second practical improvement in calenders of the common description consists in the substitution of cast iron for wood, in the construction of the connecting frames. This improvement is now common to almost every description of machinery; and when applied to the calender, it is of more than usual advantage, because, independently of the accession of strength and diminution of space occupied, the total exemption of iron from warping is of peculiar advantage in an engine so rapidly exposed to alteration of temperature as the calender must be. The entire exemption of iron framing from combustion forms also another advantage of some importance in an engine frequently heated by the application of red-hot cylinders of iron. With this cursory outline of general improvement, the next object of the present article is to afford a description of calenders in their present state of improvement, referring for illustration to the figures which are delineated in the Plate.

Smoothing Calender.

A representation of a common smoothing calender, combining in its construction all the improvements which have been detailed; will be found represented by fig. 1. Plate XLV.

The framing of this calender, as well as of the glazing calender (fig. 2.), and which will afterwards be noticed, is represented as composed partly of iron and partly of wood; the upright posts which form the lateral connections, and which contain the *bouches* or sockets in which the axes or *journals* of the cylinders revolve being of the former substance, whilst the horizontal parts at top and bottom are represented as of the latter. The latter, however, may also be very advantageously cast in iron.

The constituent parts of this calender are as follow: MA is the chief or main cylinder, which is represented as 24 inches in diameter, and five feet in length, betwixt the connecting and compressing plates at the extremities. It must, however, be premised, in order to avoid misconception, that different Engineers adopt different dimensions for their cylinders; and that those adopted and specified in the representations given, are merely selected as specimens of such diameters as are in general use, and found to answer their end sufficiently; but they may unquestionably be either extended or contracted, according to particular circumstances, without any perceptible alteration of effect, provided care be taken that the ratio of velocity be always correspondent with that of dimension.

BB are two cylinders of cast iron externally turned until perfectly smooth. Their diameter is fixed at six inches each, allowing the substance of iron to be one and a half inches, and leaving a central cavity or perforation of three inches diameter, for the reception of red-hot cylinders of cast iron, when the calender is required to operate at a heated temperature. Both extremities are perfectly open, in order that the heated cylinders, which, for the sake of convenient exposure in the furnace, should not exceed 12 or 16 inches in length, may be easily introduced at one end, and, after cooling, may be expelled at the other by fresh cylinders from the furnace. Their diameter should so far correspond with that of the

Calender. cavity into which they are to be introduced, that, in their utmost state of expansion from the heat, they may slide freely along, with as little vacant space as can safely be allowed, but without exposing them to the danger of occasional obstruction from excess of diameter.

The cylinders CC, like the main cylinder A, ought to be constructed of compressed pasteboard, and their diameter is assumed to be 12 inches. These five cylinders, with the wheels which put them in motion, constitute the whole dynamical or moving apparatus of the calender; and, at the diameters which have been assigned to them, will occupy, when in contact fit for working, a space of five feet perpendicular in whole. To this must be added the thickness of the top and bottom parts, and an allowance of two or three inches vacancy to clear these from the upper and lower cylinders. A space in whole of about two feet will be sufficient for these purposes, and the total altitude of the calender from the floor to the vertex will be about seven feet.

The cylinders revolve in *bouches* or sockets, generally of smooth hard brass or bell-metal; and all these, excepting those of the main cylinder, are so connected with the lateral framing by which they are supported, as to render them capable of being shifted upwards or downwards occasionally. This admits of altering the degree of pressure given by the cylinders, so as to suit the great variety of fabrics which are necessarily subjected to the operation of the same calender, if employed in general business. The *quantum* of pressure exerted upon the cloth is sometimes regulated by projecting levers, operating as steelyards. The short end of these being connected with the centres of the cylinders, the pressure is proportional to the weight applied to the longer extremity, and its distance from the fulcrum.

This is perhaps the best and surest mode of tempering and adjusting the quantum of pressure. The steelyards, however, require more space than the proprietors are generally willing to allot for their calenders; and, consequently, the pressure is most commonly regulated by screws. This, however, subjects everything to the discretion of the operator, and an unskilful person often injures the machinery, and even stops its motion by overscrewing the calender. At other times, he is apt to set it so open, as to permit the cloth to pass through it without receiving nearly the effect which will be derived when the calender is skilfully adjusted.

In order that the operating effect of the calender may be merely by pressure, it will be obvious that the relative velocity of rotation, communicated to each cylinder respectively, should be reciprocally as its diameter; for thus each will expose equal superficies in equal times. And to effect this, it will be equally obvious, that the diameter of the wheels (reckoned to the *pitch lines* or working parts of the teeth) should be commensurate with those of the cylinders, upon whose *axes* they are respectively placed. These diameters being respectively 6, 12, and 24 inches, and that of the wheels the same, the perimeters of this latter (avoiding minute fractions) will be nearly 18.8, 37.6, and 75.2 inches; and to deduce from these the requisite number of teeth, it is only necessary to ascertain what strength it will

Calender. be necessary to allow for each. An epicycloidal tooth, measuring .75 inch thick at the pitch line, will be abundantly strong to undergo any opposition which it may encounter in a well constructed calender; and should this be adopted, the numbers of the wheels will be

	Inches.	
Main cylinders A,	24	diameter, 48 teeth <i>nearly</i> .
Iron cylinders BB,	6	12
Extreme cylinders CC,	12	24

liable to such modification as the engineer may deem it proper to adopt, under the special circumstances of each case.

When these connections betwixt the cylinders are formed, and a sufficient moving power is applied to the main cylinder A, the whole will revolve with velocities proportional to their diameters; and as equal surfaces will be exposed by all in equal times, pressure alone will be applied at the lines of junction, and the calender will smooth, *by compression exclusively*, whatever pieces of cloth may be exposed to its operation. This pressure, it is also apparent, will take place at the four lines of contact between the cylinders, and, of course, will be four times applied during the transit of the cloth. Those who attend the calender must be careful that the pieces are fairly extended before insertion, to prevent *creasing*; and that they are regularly although loosely collected into regular folds after being calendered; and in this state delivered to those whose business it is to refold and press them into the proper folds, which they are permanently to retain, until they shall come into the possession of the consumer.

The above description of the common calender supercedes, in a great measure, what it might otherwise be necessary to detail respecting that employed for glazing. Both engines are, in fact, nearly the same; and the same calender may, by a few minutes labour, be altered so as to answer either purpose.

Glazing
Calender.

Previously to the introduction of this improvement, the operation of glazing, although performed sufficiently well, was somewhat tedious, being effected almost exclusively by the mere application of manual labour. It was performed upon a table, the cover of which was oblique to the horizon, forming with it an angle of 15° or 20°. The cloth being stretched on this, and a quantity of wax being thinly spread on its surface, the glazing was effected by the reciprocation of a smoothed flint, vibrating at the end of a rod, somewhat similar to the oscillations of a pendulum. The centre of oscillation was also moveable on a spring, in order to reduce the arc of vibration to a plane, and keep the flint in uniform contact with the cloth. But a man's power was competent to glaze only a few inches in breadth at once, and it was only by successive shiftings, that the whole breadth was successively brought under the friction of the flint. The glazing calender produces the same effect, with increased uniformity, simply by changing the relative velocities of the cylinders to each other, and generating friction, as well as pressure, at the points of contact.

Indeed, the whole changes necessary to convert a smoothing into a glazing calender, consists merely in accelerating the rotatory velocity of the main cylinder A, whilst those of the other cylinders remain

unchanged. The shifting of one wheel upon the main cylinder, and the addition of four smaller wheels or pinions to the engine, is entirely adequate to produce this effect; and, in point of fact, this is the whole extent of the improvement. The extent of alteration in the relative velocities, of course regulates the quantum of friction, and the extent of gloss which is given to the cloth; and this must be varied in proportion to the strength and density of the fabric to be glazed. As an illustration of the principle, let it be supposed, that a friction of one inch is to be communicated in every three inches of cloth, and the effect will be attained in the manner represented by the glazing calender, fig. 2. Plate XLV.

Let the wheel on the main cylinder A be reduced to thirty-two teeth, and let the power be so applied, that its own velocity of rotation shall be increased until it makes three revolutions where it formerly made only two. Then the diminished wheel, which has been substituted, in place of direct operation, will communicate rotation to the iron cylinders BB, by the intervention of two intermediate pinions DD, the diameters and teeth of which are entirely discretionary, as they affect only their own respective velocities, and not those of the cylinders in general.

Notwithstanding the extreme simplicity of this improvement, it has given very universal satisfaction, and, as the time of the patent will very shortly expire, there is little doubt of its universal adoption, to the entire supersession of the common and tedious operation of glazing.

For dressing muslins, gauzes, lawns, and other Small Calender for Light Fabrics. goods of the light and transparent fabrics, a smaller species of calender, represented by fig. 3. is employed. It consists of only three cylinders of equal diameters (generally about six inches), and is easily moved by a common winch or handle at F. The mid cylinder is iron, and the others wood or pasteboard. They are of equal diameters, and are moved with equal velocities by the small wheels at E. This machine is always used in a cold state.

The folding of cloth is so entirely regulated by fashion, that no precise rules can be laid down for its regulation. In general, as all the different manufactures of cloth have been imported from other countries, the original foldings have been copied to complete the resemblance. In the infant state of imitation there was probably some policy in this, but the continuance may be ascribed almost exclusively to the power of habit. Preservation and portability are the main requisites to be attained by folding; and these are attained by subjecting the cloth, when folded, to a very powerful compression.

To communicate this, very strong presses are employed, of which various kinds are in use.

The capstan press, which is the most usual, is represented by fig. 4. at G. They are now generally constructed of cast iron, the screw and handle excepted, which are malleable. They are tightened to a certain pressure, by merely using a lever of 10, 12, 16, or more feet in length, to turn the screw. When greater compression is required, the end of the lever is connected by a strong rope or chain with the capstan at I, which is heaved round by handspikes until the desired compression be obtained. The pieces of cloth are separated in the press

Calender. By smooth wooden boards and folds of that species of glazed pasteboard, which, from its application to this very use, has acquired the appellation, among stationers, of pressing-paper.

Water-presses, upon the forcing principle of Mr Bramah, or acted upon by the pressure of a column of water, are also employed; but the latter depend much on local situation, and cannot easily be applied in large towns like Manchester or Glasgow, where the chief command for calendering exists.

Operations connected with Calendering.

To the mechanical art of calendering, it is found expedient, in the extended states of commerce, to add many of the operations of packing, sheeting, and preparing goods for shipment, and these generally form a branch of the establishment. In order to suit the great extent and variety of manufacture practised in Britain, and to adapt these to the prevalent tastes and views of the extensive range of consumers to be supplied, a multiplicity of foldings or lappings have been necessarily adopted, few of which, probably, possess much claim to entire originality. The high, and perhaps preeminent, station which the productions of the British looms have gradually attained, seem to be rather the effect of assiduous and enterprising industry, than of great originality of invention, or precedence in mechanical improvement. Certainly, she can, at the utmost, boast of only one *raw material*, from which cloth is manufactured, as peculiarly indigenous.

At an early period, no doubt, the British wool had attracted the peculiar attention of economists and statesmen, as of paramount value; and the prohibition of its exportation became an object of legislative enactment. That manufacture, therefore, has long been the staple of England, as the linen trade, at a later period, has become that of Ireland.

The attempts to introduce both of these branches of industry into Scotland, although, during the latter part of the last century, they engrossed much of the attention, both of public bodies and of patriotic individuals, cannot be regarded as having proved eminently successful; and the progress actually made, has been almost entirely superseded and extinguished, by the more recent introduction of the cotton manufacture.

The latter branch of industry, since the splendid invention of spinning by the aid of machinery, has, indeed, made most rapid advances in every part of the United Kingdom; and has attained to a height, which has, perhaps, absorbed a greater portion of national industry, than consumers can easily be found to employ. The extension of external commerce has constantly supplied the raw material at easy, and, generally, moderate rates; and even the India Company have long ceased to oppose to it any very formidable competition in the market.

The silk manufactures of Britain have never been carried to a very great extent; and whatever may have, directly or indirectly, tended to regulate the finishing, folding, and preparing of British goods for the various markets of consumption, will chiefly refer to the three former branches of manufacture.

Extensively as the woollen trade is carried on, it is, in a great measure, absorbed either by internal or colonial consumption, and does not, therefore, enter

so generally into actual competition with the cloths of other nations, as to render it either peculiarly desirable that its marketable aspect should be either servilely copied from those of other countries, or very peculiarly distinguished from them. The chief object appears to have generally been, to prevent the intrusion of foreign cloths and stuffs into our own markets; and hence adopting their usual folds into such rolls, as most effectually preserve the dressed surface from acute creases, is found to be most expedient and convenient, the goods being distinguished by letters denoting them to be "British manufacture," on the ends of the pieces.

In the Irish manufactures of cambrics and linens, the case is almost entirely reversed. From the superiority of climate, the French flax is admitted to be of finer appearance; and although the importation of manufactured cambrics be strictly prohibited, the restraint, during periods of peace, has always been considerably evaded, in consequence of the demand experienced, and the reputation in which they are held. Indeed, it was found generally most expedient, by many retailers, to sell Irish cambrics under the title of French, and hence the fold was correctly imitated. The pieces, after being folded into lengths of about 12 inches, and twice laterally doubled, until the whole breadth of 34 inches was reduced to about 8½ inches, were subjected to a powerful compression in the press until fully flattened. They were then packed in purple coloured wrappers or papers, and a small engraved card or ticket was attached to each piece, specifying the length, generally about 8 or 8½ yards. The cards were attached by a silken string, so as to be easily cut away with a penknife or pair of scissors, in order to avoid seizure; and French or Irish goods were sold indiscriminately as "foreign cambrics." Custom has even carried this practice farther; and cotton cambrics, which are avowedly *British manufacture*, and subjected to no risk whatever, because easily distinguishable from any cambric manufactured from flax, are put up into the same folds, papered, and ticketed, in exactly the same manner.

In linens, hollands, and sheetings, whether of foreign or Irish manufacture, the same fold is also employed; and in cotton shirtings and sheetings, is closely imitated. The form is that of a cylindrical roll, somewhat flattened by subsequent compression; and, in general, all dense fabrics, whether of linen or of cotton, are rolled up and compressed in a similar manner; the object of which is, evidently, safety, and diminution of space, in land carriage or exportation.

In others of the extensive varieties of cotton cloths of British manufacture, some are avowed imitations of the manufactures of Hindostan, whilst others profess no such imitation. Very few among the manufactures of Lancashire are either distinguished by Indian names, or copied from Indian cloths, although some of great extent are directly so. Calicoes, cosacs, and jaconets, for printing, as well as Ballusore, Bandana, and Pullicate handkerchiefs, are amongst the leading articles of the latter description; whilst amongst the latter may be classed the very extensive manufactures of corduroys, thicksetts, velveretts,

Calender. velveteens, &c. although their origin is also probably Asiatic, but because well known and manufactured by the Genoese, French, and other European nations, even before the discoveries of De Gama, and other mariners, had first laid open the maritime intercourse with India by the Cape of Good Hope.

When, at a period infinitely more recent, the splendid invention of spinning cotton by the agency of machinery, to any degree of fineness, afforded new scope to the British weaver, the imitation of the lighter Indian fabrics fell chiefly into the hands of the Scottish weavers; for executing which, they had been, in a considerable degree, previously prepared, by their habits of weaving lawns in imitation of the French, as well as their lighter fabrics of silk and thread gauzes. To their share, in consequence, fell the bouks, mulls, and japans, almost exclusively; as well as the lighter *jaconets*, designed for ornament, from the needle and tambour frame. And whilst they have made no successful attempt to compete with their Lancashire brethren in the dense fabrics of corduroys, quiltings, and other ponderous articles, they have shared with them the manufacture of the middling textures of cambrics, Pullicates, and gingham.

Indeed, whatever prepossession may, at an early period, have existed in favour of the real Indian fabrics, it has now so entirely subsided, as to possess no influence whatever in swaying general opinion. The British workmanship has proved itself long ago so decisively superior to the Indian, both in spinning and weaving, as to eradicate every doubt in the minds of all who are really competent to decide the question of comparative superiority. Still, however, candour will compel us to allow, that the Indian possesses advantages in the rich qualities of his cotton, and the brilliancy of some of his dyes, which, in some degree, compensate for the immense superiority of the British skill and machinery, and which, to those who examine superficially, may appear to entitle him to the preference.

Nothing, therefore, exists in the cotton manufacture which could, in general cases, prompt to a servile imitation of external appearance for the purposes of deception; and the Indian mode of lapping their cloth is too rude and laborious to admit of its being copied as a matter of expediency. Their method consists merely in doubling a piece of twenty yards, to reduce its length to ten yards; which is again doubled, in order to reduce it to five; and thus they continue to redouble, until the piece be reduced to a moderate length, capable of being contained in a chest or bale. Thus often redoubled, an Indian piece cannot be examined throughout, unless the whole piece be again unfolded; and this, in large transactions, would be utterly impracticable.

British muslins are folded generally to a yard in length, with a small allowance for extra measure; and as the folding is alternately from right to left, every part can be instantly examined upon a table or counter, every fold opening as easily as the leaves of a book, in its most state. The piece, when folded, is reduced by doubling it longitudinally to about 19 inches, and it is then folded across to the breadth of about 18 inches. An ordinary sized trunk, 29 x 19

inches, thus contains three layers of pieces; in which package, goods for exportation to the colonies are generally packed; the trunk there forming an article of merchandise as much in general demand as the muslins which it contains.

Even the Indian ornaments of gilt silver threads, which were at first woven into one end of each piece, although they did not exceed the value of twopence each, have been either greatly curtailed, or totally given up upon principles of economy. Even the cost of this trivial ornament has been computed to have amounted annually in Glasgow and Paisley to about L. 30,000.

Pullicate, and other handkerchiefs, are most commonly folded up in dozens. For the African, and some other foreign trades, pieces containing only eight handkerchiefs are preferred. These are still imitations of Indian precedents, confined to markets where competition continues to exist, not only with the British Company, but with Americans, and others trading to India. A species of pale orange-coloured India handkerchief, distinguished by the name of *Mudrus*, being in extensive reputation in the Caraccas, and other Spanish settlements in South America, at the period of the capture of Trinidad in 1795, patterns were procured by some British traders, who ordered very large quantities to be manufactured in Scotland, of the same quality and appearance. With such effect were these imitated in texture, in dye, in finishing, and even in the packages, that some hundreds of pieces sent to London for exportation, were actually seized at the Custom House, as India goods, either illegally imported, or stolen from some of the Company's ships in the river. A scrutiny, however, clearly ascertained that these goods were not Indian, but British; and that no trespass against either the privileges or the property of the Company had been even attempted. The goods were of course released, and permitted to proceed to their destination, where, after examination and trial, it was found totally unnecessary longer to conceal their real origin, and a very extensive trade, through direct channels, has been since carried on for similar goods.

From the above general and cursory sketch, it will be obvious that the management of an extensive calendering establishment will require, on the part of its conductor, not only a competent knowledge and experience of the mechanical operations, and duties of his particular profession, but that a more extensive mercantile acquaintance with the demands, habits, and tastes of particular markets, will conduce equally to his own interests, and those of his employers. From the variations of markets, and fluctuations of mercantile transactions, there can be no precise or definite limit to the extent of such knowledge. It is only by constant attention and sedulous inquiry, that he can preserve accuracy, in what is liable to almost daily change. His immediate employers will, no doubt, be often both able and desirous to supply him with this. But, as even they must sometimes be liable to error or deception, he ought to omit no opportunity of extending his inquiries, and arriving, as nearly as he can, at the most comprehensive and unambiguous information. (L. L.)

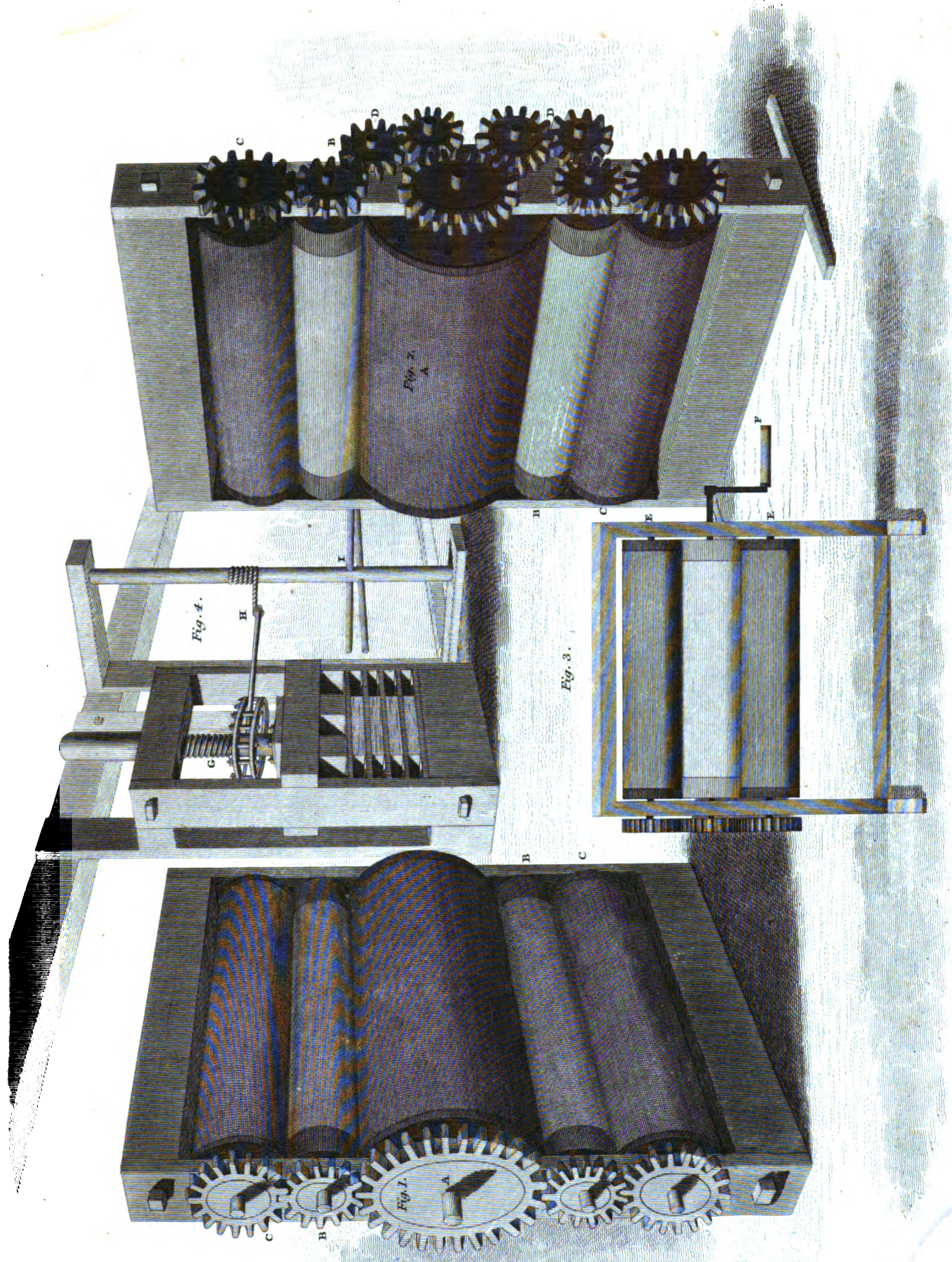

Fig. 4.

Fig. 3.

Fig. 2.

Fig. 1.

Published by A. Conestable & Co. 1817.

Duncan

Engraved by W. & D. Lizars, Edinburgh.

Calico-
Printing
Cambridge-
shire.

CALICO-PRINTING. This important art is treated of under the article **DYEING** in the *Encyclopædia*, in the third chapter of that article; but as the nature of this species of Printing, and the processes employed in it, require to be more fully examined and described, we shall resume the subject under the same head, or under that of **PRINTING**, as circumstances may best permit.

Form and
Extent.

CAMBRIDGESHIRE is divided into two parts by the river Ouse. Its most northerly division, which is principally composed of the Isle of Ely, is bounded by rivers, and their communicating branches. The limits thus formed are so intermixed, as with difficulty to be traced. The southern half has an indented and undistinguished boundary-line on the adjacent counties. The form of Cambridgeshire bears some resemblance to that of the human ear, the county of Huntingdon cutting deeply into its western side by a circular projection. The number of acres assigned to it in the *Encyclopædia* is taken from Dr Halley, but Dr Boeke reduces them to 530,000; and they are still farther reduced in the agricultural report, and in the returns in 1803 of the poor-rates, to 448,800, and 439,040 respectively. When the original agricultural report was made in 1794 by Mr Vancouver, he calculated that, of the 448,000 acres, there were 132,000 open field, and 150,000 waste and unimproved fen; but since that time, both these descriptions of land have been very considerably reduced by enclosure and cultivation.

Surface.

The surface of this county presents considerable variety. The northern part, including the Isle of Ely, is chiefly fen land, and perfectly level, intersected with numerous canals and ditches, and abounding with windmills, for the purpose of carrying the water from the lands. This district is naturally a bog, formed by the stagnation of the water from the overflowing rivers. It comprises nearly half of that extensive tract, called the Bedford Level, the whole extent of which is 400,000 acres, and not 300,000, as stated in the *Encyclopædia*. This great level has been, from an early period, divided into three parts, the north level, the middle level, and the south level. The largest portion of the middle level, and a considerable part of the south level, are in Cambridgeshire, comprehending the Isle of Ely, and a few parishes to the south-east of the Isle. The principal of the drains, by means of which this immense fenny district has been, in a great measure, rendered either rich meadow or arable land, are the Bedford old and new rivers, which run navigable in a straight line upwards of 20 miles across the county, from the Great to the Little Ouse. There are some rising grounds in this part of the county, on the most considerable of which the city of Ely stands. Those parts of Cambridgeshire, which lie adjacent to Suffolk, Essex, and Hertfordshire, have their surface varied by gently rising hills and downs. The Gogmagog hills, which begin about four miles to the south-east of Cambridge, and which are one of the terminations of the range of chalk hills that commence in the south-west of England, are the highest in the county; but their height is very inconsiderable. The district which extends from these hills to Newmarket, is bleak and thinly inhabited. This dis-

VOL. II. PART II.

trict is connected with that vast tract of land, which, extending southwards into Essex, and northwards through Suffolk into Norfolk, forms one of the largest plains in the kingdom.

The substrata of this county are chalk, *clunch*, Soil gravel, *gault*, sand, *silt*, and peat-earth. The chalk extends through the hilly part of the county from Royston to Newmarket. The *clunch*, an impure limestone, chiefly abounds in the parishes of Burwell and Iselham. On the east and west sides of the upland division of the county, *gault*, a stiff blue clay, chiefly prevails. The sand enters Cambridgeshire from Bedfordshire, in the parish of Gamlingay. In the northern extremity of the county, near Wisbeach, *silt*, a fine sea-sand, is found. The peat-earth extends through the whole of the fen-land.

The principal rivers are the Ouse, and Granta or Rivers. Cam. The Ouse enters the county between Fen Drayton and Erith; thence it runs eastward through the fens, till, at some distance above Denny Abbey, it takes a northerly course, and, passing Streatham, Ely, and Littleport, flows into Norfolk. From this river are many cuts, called *loads*. The Cam enters the county to the west of Gilden Morden; thence flowing to the east, it receives several rivulets. Near Grantchester, its stream is enlarged by the united waters of several rivulets from Essex. After their junction, it takes a northerly direction, and, having passed Cambridge and several villages, it falls into the Ouse in the parish of Streatham.

Besides the numerous canals in the fenny district, Canals. principally for the purposes of draining the land, there are the Cambridgeshire Canal, which commences in the Ouse at Harrimere, and terminates at Cambridge. A cut of 3 miles extends to Reche, and another of 3½ miles to Burwell; and the Wisbeach canal, which joins the Wisbeach river at the old sluice in the town, opening a communication with Norfolk, Suffolk, and other places.

The climate of Cambridgeshire differs considerably in different parts. In the south-east it is cold and bleak; in the fenny district damp and unhealthy, though much less so than formerly; in the south and south-western districts, the climate is the mildest, most agreeable, and healthy.

Estates vary much in size. There are many large Landed ones, especially those of the Earl of Hardwicke and Property. the Dukes of Bedford and Rutland. College tenures are numerous. There are some large farms of 1000 acres or more, but the general size is from 100 to 500 acres.

Cambridgeshire is not celebrated as an agricultural Agriculture. county. It may be considered as chiefly arable. Wheat is grown principally in some parts of the fenny district, and in the south and south-western parts of the county. Barley is cultivated in these parts, and in some of the more fertile portions of the south-east district. Immense crops of oats, of good quality, are grown in the fenny district, and also in most other parts of the county. It is supposed, that about one-fourth of the fen-lands are cropped with cole, which is principally sown to be eaten green with sheep, very little being now cultivated for the seed. The cultivation of hemp and flax is carried on to a considerable extent, in that part of the county which

Cambridge-shire.

borders on Norfolk, particularly in the parishes of Upwell and Wolney. Saffron has been very little, if at all cultivated, for upwards of 40 years. In some parts mustard is a favourite and valuable crop. Sedge is cultivated near Chippenham; but the cultivation of the reed is rapidly decreasing, in consequence of the improvement of the fens. White seed, or fen-hay, is grown abundantly in several places. It increases the milk of cows. Oziers are grown in the Wash, as well as in many parts of the fen: they are a profitable crop in these districts. So great is the value of turf, that the land producing it has been sold at from L. 50 to L. 80 *per acre*. At Ely, Soham, Wisbeach, &c. are many large gardens, producing so abundantly of vegetables and common kinds of fruit, as to supply not only the neighbouring towns, and counties, but even London. Great quantities of strawberries are grown in the vicinity of Ely, which are chiefly conveyed in barges to Lynn, and carried thence to Newcastle and other places in the north of England. There are numerous and large orchards in the same districts as the gardens; their chief produce is apples and cherries. Soham is remarkable for the latter.

Pasture.

That district of the county which, by old authors, is termed the *Dairies*, comprehends the parishes of Shengay, Wengy, Whaddon, &c.; but the dairy farms in this district are, at present, much less considerable than those in the parishes of Chatteris, Mepal, Sutton, Cottenham, Soham, Ely, and Streatham. The whole number of cows kept in this district is supposed to be between 9000 and 10,000; in the parish of Cottenham alone, about 1500 are usually kept; in Willingham, about 1200. These two parishes make the cheese, so much esteemed, which goes by the name of Cottenham cheese; the parish of Soham is also esteemed for good cheese. Little cheese is made in other parts of the county; rearing of calves and making of butter being the chief dairy management. The butter is sold, rolled up in pieces of a yard long, and about two inches in circumference: this is done for the convenience of the colleges, where it is cut into pieces called *parts*, and so sent to table; its quality is excellent. The cows kept on the dairy farms are mostly the breed of the county: most of the calves that are suckled, are sent to the London market. Immense numbers of sheep are pastured on the heaths and commons, with which the south and south-western districts of this county are intersected. The downs in the vicinity of the Gogmagog Hills, are also chiefly used as sheep walks. The principal breeds kept here, are the Norfolk and west country; in the fens the most prevalent sort is a cross between the Leicester and Lincoln. The Cambridgeshire farmers think themselves unrivalled in cart-horses; they are of the large black breed; in the fens they are a source of great profit. In Cambridgeshire there is also a peculiar breed of hogs, some of which are so large as to fatten to forty stone, fourteen lbs. to the stone, at two years old.

Draining, Irrigation, and Warping.

From the nature of the northern division of the county, great attention has necessarily been paid to draining; and, in some places, advantage has been taken of the numerous rivers to irrigate and *warp* land.

The interior drainage of the fens is performed principally by mills; one or two steam-engines have been erected for that purpose, and will probably answer better. There is a large tract of meadow land at Babraham, which has been irrigated from the time of Queen Elizabeth, and is supposed to be one of the oldest instances of this mode of improving land in the kingdom; it was first irrigated by Pallavicino, who was Collector of Peter's Pence at the death of Queen Mary, and who, turning Protestant, applied the money thus obtained to the purchase and irrigation of this estate. The practice, however, though evidently beneficial, has extended very little. Near Denver sluice, on the Ouse, some land has been *warped* by letting the muddy water of that river upon it, and then throwing it back by means of a wind-mill.

This is by no means a manufacturing county. At *Mantle*, Ely there is a pottery for coarse ware; and at this town, Chatteris, and Cambridge, excellent white bricks are made. Lime and chalk are a source of considerable trade and profit; the lime in the greatest estimation is that which is burnt at Reach. At Cherryhinton, at the foot of the Gogmagog Hills, are great chalk pits, noted for the marine productions they contain, and for the many rare plants growing in their vicinity. Elephants' grindstone, and other animal remains have been found in a gravel pit near Chesterford, and a small tortoise in flint, at Milton. On the borders of Norfolk, a little yarn is spun for the Norwich weavers. Malt is made to a considerable amount in the north-west part of the county. There are several mills for preparing oil from cole and rape-seed, at Wiltlesford, Sawton, &c., and a pretty extensive paper manufactory at the latter place. Near Cambridge is annually held one of the greatest fairs in England; it is called Stourbridge or Sturbich fair, and is under the jurisdiction of the university. It begins September the 19th, and lasts a fortnight; it has, however, been declining for many years.

A very curious example, and unquestionably one of the oldest in the kingdom, of Saxon architecture, occurs in the remains of the conventual church of Ely. This building is undoubtedly of as early a date as the tenth century, having been erected in the reign of King Edgar. The two transepts of Ely cathedral, afford specimens of the more massy kind of architecture introduced by the Normans; they were built towards the end of the eleventh century. St Sepulchre's church at Cambridge, affords a curious specimen of that species of architecture, which was introduced into this country, in imitation of the church of the Holy Sepulchre at Jerusalem; it is supposed to be the oldest of this form in England, and to have been built in the reign of Henry I. There are some instances in this county of the pointed arch, enriched with Saxon mouldings; this style was the immediate forerunner of the Gothic. Soham Church, the south door way of St Giles in Cambridge, and the north and south door ways of St Mary's Church in Ely, are specimens of this species of architecture. One of the most ancient buildings in this county, in which the pointed arch makes its appearance, is the great Tower at the west end

Cambridge-shire. of Ely Cathedral, and the south transept adjoining; they were erected between 1174 and 1189. Some traces of Saxon architecture may be observed in this part of the cathedral. The early or simple Gothic may be seen in the vestibule at the west end of Ely cathedral, in Jesus College Chapel, Cambridge, and in the chancels of Foxton, Kennett, and Cherryhinton churches. Of the Gothic architecture of the fifteenth century, especially in the reign of King Henry VII. which was distinguished by the abundance of its rich tracery, the finest and most perfect example is found in the magnificent chapel of King's College in Cambridge.

Antiquities. There are not many remains of antiquity in this county. The most remarkable are the ditches, which formerly extended from the woods on the east side of the county to the fens. The most entire is called the *Devil's Ditch*, and extends from Wood-ditton or ditch-town, to Reach. Near this latter place, it is most perfect, the works consisting of a deep ditch with an elevated *vallum*, the slope of which measures 52 feet on the west, and 26 on the east side. The whole of the works are about 100 feet in width. The origin and intention of these ditches are not known; they are certainly very ancient, and were probably formed for the purpose of defence.

Poor-rates. By returns made to the Board of Agriculture in the year 1804, it appears that the poor-rates rose between 1790 and 1803 from 4s. 11d. to 5s. 8½d. in the pound; the expence of maintaining them from Easter 1802 to Easter 1803, amounted to the sum of L.55,954, 14s. 11d. In the year ending the 25th of March 1815, the parochial rates in 181 parishes amounted to the sum of L.63,854, 13s. 1½d.; 44 parishes had made no returns.

Population. In the year 1377, the number of persons charged in this county to a poll-tax, from which the clergy, children, and paupers were exempted, was 37,350; but it seems doubtful whether it was exclusively of the town of Cambridge and city of Ely, in each of which 1722 persons were taxed. If they were taxed separately, the total number in the county would be 30,794. In the year 1700, there are supposed to have been 76,000 inhabitants: and, in the year 1750, 72,000. By the returns made under the act of Parliament, for ascertaining the population of the kingdom, in 1800, there were then 16,451 houses in Cambridgeshire, of which 16,189 were inhabited. The total number of inhabitants is stated to be 89,346, of whom 44,081 were males, and 45,265 females. Of this total number, there were 38,045 principally employed in agriculture; and 11,988 in trade, manufactures, and handicrafts. The following is the result of the population returns in 1811:

Houses inhabited,	-	-	17,282
Families inhabiting them,	-	-	21,022
Houses building,	-	-	93
----- uninhabited,	-	-	257
Families chiefly employed in agricul- - ture,	-	-	12,831
----- in trade, ma- - nufactures, and handicrafts,	-	-	5903
All others, not included under these heads,	-	-	2688

Males,	-	-	50,756
Females,	-	-	50,353
Total in 1811,	-	-	101,109
----- in 1800,	-	-	89,846
Increase,	-	-	11,768

Cambridge-shire
|
Camera Lucida.

It will be observed that, in the year 1800, there were 1184 more females than males in this county, whereas, in the year 1811, there were 403 more males than females.

See Gooch's *Agriculture of Cambridge*.—*Beauties of England and Wales*, Vol. II.—*Lyson's Magna Britannia*, Vol. II. Part 1. (c.)

CAMERA LUCIDA. Dr Hook's instrument of this name is described in the *Encyclopaedia*, under the title CAMERA LUCIDA. The instrument which is to be spoken of here, and which differs from Hook's both in its construction and in the purpose it is designed to serve, is one of the many ingenious inventions of Dr Wollaston. Its use is to facilitate the perspective delineation of objects.

If a piece of plain glass be fixed at an angle of 45 degrees with the horizon, and if, at some distance beneath, there be a sheet of paper laid horizontally on a table, a person looking downwards through the glass will see an image of the objects situated before him; and as the glass, which reflects the image is also transparent, the paper and pencil can be seen at the same time with the image, so that the outline of the image may be traced on the paper. The image is an *inverted* one. This is the simplest form of the instrument, and may be constructed extemporaneously by fixing on a stand a plain transparent glass, with its surfaces ground parallel, or a piece of Mascovy glass, at an angle of 45 degrees with the horizon; a card with a small hole in it will serve as a sight for keeping the eye steady in one situation, whilst the pencil is tracing the image.

If there be a plain mirror at an angle of 22½ degrees with the horizon, and a piece of plain transparent glass be placed near it, at an angle of 22½ degrees with the vertical, the rays from the object will be twice reflected before they reach the eye, and consequently, on looking down through the transparent glass, an *erect* image is seen, and the pencil may be drawn over the outlines of this image so as to leave a perspective representation on the paper. This disposition is seen at fig. 1. Plate XLVI. where *bc* is the mirror, *ab* the transparent plain glass.

As the image and pencil are at different distances, they cannot be both seen in the same state of the eye. To remedy this inconvenience, a convex glass is used, of such focus as to require no more effort than is necessary for seeing the distant objects distinctly. By means of this lens, the image will appear as if it were placed on the surface of the paper. In fig. 1. *bd* is a convex glass of 12 inches focus, at *e* the eye is placed; *fghe* is the course of the rays proceeding from the object to the eye.

Those whose eyes are adapted to seeing near objects alone, will not derive advantage from the use of a convex glass, but will require a concave glass to

Camera
Lucida.

be placed at f , in the course of the rays from the object to the reflecting surface. In fig. 2. Plate XLVI. ik is a concave-glass placed in the above-mentioned situation; it is so disposed as to be turned at pleasure into its place, as the sight of the observer may require. Persons whose sight is nearly perfect, may use either the concave glass placed before the reflecting surface, or the convex glass placed between the paper and the eye.

Usual form
of the Ca-
mera Lu-
cida.

In the actual construction of the instrument, a prism is used instead of a mirror and a plain glass. The rays from the object fall upon the surface bc of the prism fig. 2. This surface bc is inclined $22\frac{1}{2}$ degrees to the horizon. The refractive power of the glass allows none of the rays in this situation to pass out; they are all reflected from the surface bc to the surface ab , and from that to the eye; ab makes an angle of 135 degrees with bc , and $22\frac{1}{2}$ degrees with the vertical. The eye cannot see the pencil through the prism as it does through a plain glass; therefore, in order that the pencil may be seen, the eye must be so placed that only a part of the pupil may be above the edge of the prism, as at e , fig. 3.; and then the reflected image will be seen at the same time with the paper and pencil. There is a small piece of brass perforated with a hole, and moving on a centre at e , fig. 2.; this serves to keep the eye in one position, as it must be, that the image may be steady, and also to regulate the relative quantities of light to be received from the object and from the paper.

The instrument, being near the eye, does not require to be large. The smallest size which can be executed with accuracy is to be preferred, and is such that the lens is only three-fourths of an inch in diameter. Fig. 4. shows the instrument on its stand, and clamped to a board. The joint by which the prism is attached to the stand is double. The whole instrument packs in a box eight inches by two, and half an inch deep.

Its Uses.

This instrument serves for drawing objects of all forms, and consequently also for copying lines already drawn on a plain surface. If it is required that the copy shall be of the same size as the original drawing, the distance from the drawing from the prism should be the same as the distance of the paper from the eye-hole. No lens will be necessary in this case, because the image and the paper being both at the same distance from the eye, coincide without the aid of a glass.

In order to have a reduced copy of a drawing, the drawing is to be placed at a distance from the prism greater than the distance of the paper from the eye-hole. If the distance is twice as great, a copy will be obtained, in which the lines are of one-half the size of the lines in the original, and so in proportion for other distances. A lens is necessary, that the eye may be enabled to see at two different distances; and, in order that one lens may serve, the distance between the eye-hole and the paper should be variable; to that effect, the stand is susceptible of being lengthened or shortened at pleasure.

The length of the stem is adjusted upon optical principles. When a distant object is to be delineat-

ed, the rays coming from it, and reflected by the instrument to the eye, are parallel, and it is required that the rays proceeding from the paper to the eye should also be parallel. This is accomplished by interposing a lens between the paper and the eye, with its principal focus on the paper. When the object to be delineated is so near that the rays which come from it to the eye are divergent, then it is required that the rays from the paper should likewise be divergent in the same degree, in order that the paper and the image may both be seen distinctly by the same eye; for this purpose the lens must be placed at a distance from the paper less than the distance of its principal focus. The stem of the instrument is marked at certain distances, to which the conjugate foci are in the several proportions of 2, 3, 4, &c. to 1, so that distinct vision may be obtained in all cases by placing the original drawing more distant.

If the convex lens be transposed to the front of the prism, and the proportional distances be reversed, a magnified image of the object will be obtained.

This instrument has deservedly come into use. Its Compani advantages when compared with the camera obscura with the are, 1st, That it is small and easily carried about. Camera 2dly, That no lines are distorted, not even those (Lucida) most remote from the centre, whereas, in the camera obscura; the lines which are not near the centre of the field are more or less distorted. 3dly, In the field of the camera lucida 70 or 80 degrees may be included, whilst the distinct field of the camera obscura does not extend beyond 30 or 35 degrees at most. The specification of Dr Wollaston's patent for the camera lucida is inserted in the *Repertory of Arts*, Vol. X. 1807, p. 162, and his description of the instrument in *Nicholson's Journal*, Vol. XVII.

If the camera lucida be fixed at the eye-glass of a The Appli- telescope, it will reflect to the eye the image of the tion in the objects in the field of the telescope, so that a drawing Telescope of the image may be made. See Dr Brewster's *Account of some Philosophical Instruments*. A plain reflecting glass, fixed at an angle of 45 degrees with the horizon, and placed so as to receive the rays from the eye-glass of a telescope, will also give an image of the objects in the field, so situated that the image may be traced with a pencil. Varley's patent graphic telescope is upon this principle. In order that the field may be large, the magnifying power of the telescope should be small.

The inherent qualities of all the instruments for Various drawing in perspective being closely allied, it will Modes of be proper to say something of the principles on making which these instruments are formed, and to mention Drawing some that are not described in other parts of an Object this work.

To make a perspective drawing of an object is to lay down on paper a section of the perspective cone, whose apex is at the eye, and whose base is the object. An experienced draughtsman can draw the figure of this section without the aid of instruments. Others who have not acquired the facility of drawing the image they see, must have recourse either to *measurement*, or to the *instruments, which bring the image under the pencil.*

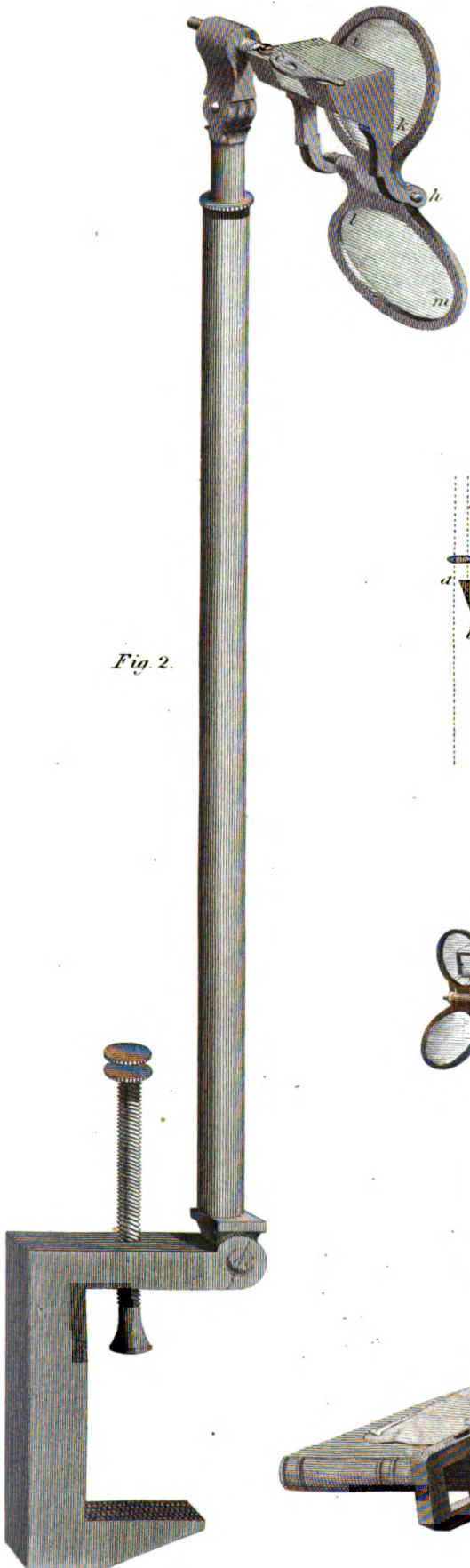

Fig. 2.

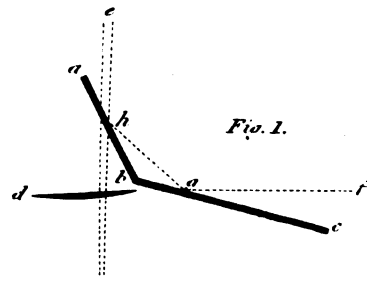

Fig. 1.

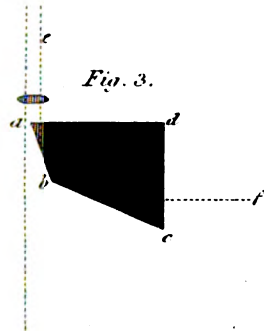

Fig. 3.

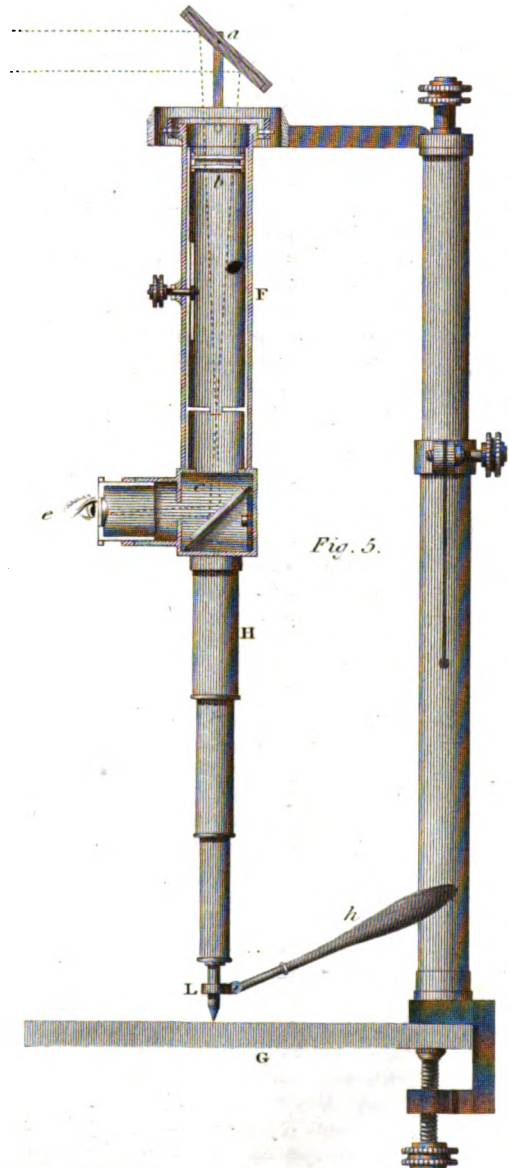

Fig. 5.

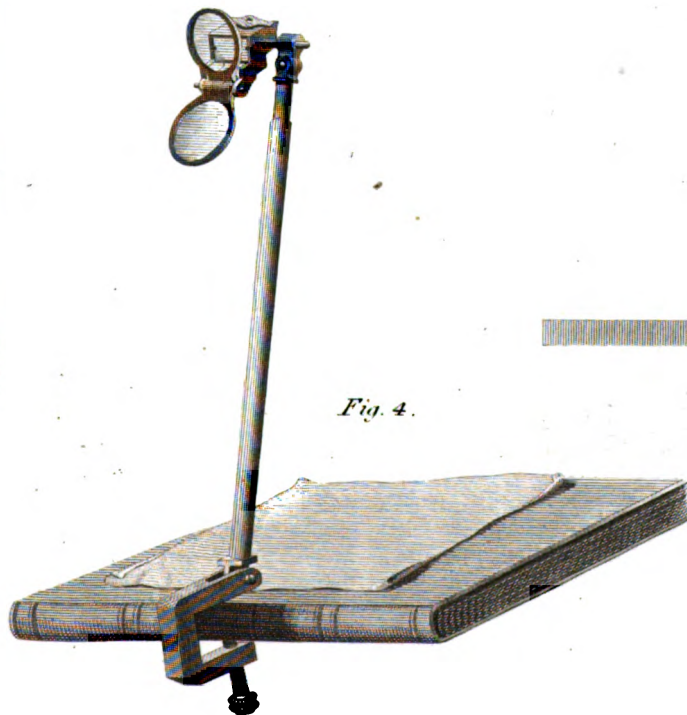

Fig. 4.

Camera
Lucida.

Drawing by measurement is performed by actually measuring the height of the principal parts of the object, and their horizontal distance from the eye, together with the distance of the paper from the eye, and from these dimensions the drawing is constructed by the systematic rules of perspective.

Another mode of obtaining a drawing by measurement, is to measure the angles at the eye. Suited to this purpose are theodolites, astronomical quadrants, or other instruments, capable of measuring vertical and azimuthal angles at the eye. The angles to be measured are, the angles of altitude, and the angles of azimuth, between the point of sight and the principal points of the object; and if the tangents of the azimuthal angles be laid down with a radius equal to the distance of the paper from the eye, and the tangents of the angles of altitude with a radius equal to the distance of the paper multiplied by the secant of the azimuth, the situation of the principal points of the drawing will be determined. Or, if the instrument is capable of measuring angles in any plane, the angles between the principal points of the object and the point of sight are to be observed, and the azimuthal angles of these principal points with the point of sight; and the tangents of both are to be laid down on the paper, with a radius equal to the distance of the paper from the eye.

But these two modes by measurement are long, particularly the first. Usually, therefore, the instruments to which recourse is had for facilitating the operation of drawing, are such as give an image or section of the perspective cone on a plain surface, so that the pencil may be drawn over the outline of the image. These instruments may be considered under two heads. The first comprehending those in which the pencil is immediately drawn over the lines of the image. The second those in which the pencil has a motion parallel to that of the point which moves over the lines of the image.

Of the first kind are the following. 1. The tracing pane, a very simple and convenient instrument, consisting in a transparent plate of plain ground glass, or of Muscovy glass, placed vertically between the object and the eye; whilst the eye is kept fixed by a sight, the outline of the image is drawn on the glass with Indian ink. 2. Or the upright glass may be divided into small squares by lines crossing each other, and the paper on which the drawing is to be made, being similarly divided, the particular intersections on the glass that cover the principal points of the object are observed, and these points are laid down on the corresponding intersections on the paper. 3. The image seen in a plain mirror, may also be drawn on its surface with Indian ink. 4. In the camera obscura, different forms of which are described in the *Encyclopædia* under the articles DIOPTRICS and OPTICS, the image to be drawn is formed at the focus of a lens. 5. In the camera lucida the reflected image is used.

In the second division of the instruments which give a section of the perspective-cone susceptible of being delineated, the pencil does not move immediately over the lines of the image, but moves parallel

to these lines. 1. There is a rod which can be moved in all directions, consistent with its remaining parallel to itself. If one extremity of this rod be moved in space over the outlines of the image which the eye sees, a pencil at the other extremity will necessarily move with a similar motion, and form a drawing of the object on paper. In Sir Christopher Wren's instrument, of which he has given the description and figure in the *Philosophical Transactions*, Vol. IV., the rod is suspended by strings passing over pulleys, and the ends of the strings are fixed to a counterpoise. On a similar principle is Peacock's instrument, described in the *Philosophical Transactions*, Vol. LXXV., p. 366; and the instruments treated of in the *Stockholm Transactions* for the years 1760, 1774, and 1790. 2. The pencil may delineate the base of a cone similar and opposite to the perspective cone. If the rays from the extreme points of an object cross on the ray from the centre, as they do in passing through a small hole into a dark room, and if it be supposed, that in the place of one of the rays a slender inflexible rod is substituted, moveable on a centre at the hole, when this rod is moved, so that its outer extremity goes over the outlines of the external image, a pencil fixed to its inner extremity will form an inverted drawing of the object. Of this nature is the optigraph of Ramsden and Thomas Jones, described in the *Philosophical Magazine*, Vol. XXVIII. 1807, p. 67. The image of the object is seen in a telescope. There is a piece of plain glass near *c* in the focus of the eye-glass of the telescope F, Plate XLVI., fig. 5. On the centre of this piece of glass is a dot: *a* is a plain mirror, inclined so as to reflect the image of the object down into the telescope; this mirror remains fixed, whilst the telescope is moveable on a universal joint at its object-glass *b*. Near *c* is another plain mirror, which reflects the rays to the eye-glass. The eye being placed at the eye-glass at *e*, the telescope is to be moved by the handle *h*, so that the dot in the focus of the eye-glass shall pass over the outlines of the image seen by the eye, and the pencil at L performing a similar motion to that of the dot, and sliding freely in its sheath, presses with its weight on the paper: a drawing of the object is the result. If the stand and slider H be lengthened, an enlarged drawing will be obtained. The instrument packs in a box 14 inches by 6 and 3. (v.)

CAMPER (PETER), eminent for his extensive knowledge in the various branches of Medicine, Zoology, and Comparative Anatomy, and for his taste in the Fine Arts, was born at Leyden, May the 11th, 1722. His family had long held distinguished situations in the magistracy of that city, where his grandfather had exercised the profession of medicine. His father, Florent Camper, was a Protestant clergyman, and had officiated in that capacity for some years at Batavia; but had returned to his native country in 1713, after marrying Sarah Ketting, who was born of Dutch parents, at Surat. Florent Camper was an enthusiastic admirer of painting, and took great delight in the society of artists, whom he treated with the greatest liberality,—his purse being

Camera
Lucida
Camper.

Camper.

ever open to such as needed his assistance. He was much connected with the learned men who adorned the University of Leyden at the beginning of the last century; and was on terms of intimate friendship with the great Boerhaave. Young Camper has, no doubt, been greatly indebted for his success to the fortunate circumstances in which he was placed in early life; being thus surrounded by men of enlarged and cultivated understandings, eminent for their taste and learning, and having, at the same time, every incentive that a wise education could supply to emulate those excellent models; but nature had besides endowed him with that inherent desire of knowledge, that capacity, and that vigour and activity of mind, which, united as they were with a robust constitution of body, enabled him to reap the full benefit of these advantages. He gave very early proofs of his possessing those mental qualities, which lay the foundation of future eminence; and his father, discerning with delight the auspicious dawn of his genius, judiciously removed whatever might cramp its growth, and avoided imposing on him as a task those instructions and attainments, which he seemed so well inclined to acquire and pursue as an amusement.

He applied himself, at an early age, to drawing and painting, under the tuition of Moor and of his son, both of whom were celebrated artists, and soon became remarkably proficient in these accomplishments. He derived, in the course of his life, immense advantage from the skill with which he used his pencil in delineating any object in which he was interested, whether among the works of art, or the productions of nature,—or whether they were the offsprings of his own conception, in the course of his philosophical researches. The value of this acquirement, as an object of early education, is not, perhaps, in general, sufficiently appreciated. The power of conceiving readily, and with correctness, mechanical forms, is one of the most useful results that practice, in the delineation of objects, can confer, and is of incalculable advantage in a variety of pursuits, with which such a talent might not, at first sight, seem to be immediately concerned. There is no doubt, for instance, that it must remove many difficulties in the study of Geometry, by facilitating the conception of figured space, the properties of which are the subjects of that science. An accurate knowledge of Anatomy is still more directly dependant upon the same power of apprehending the relations of form. The progress which Camper made in this branch of science, and the range of inquiries to which he afterwards made his knowledge subservient, are striking illustrations of this position.

He was indebted to Laborde for his first lessons in Geometry; and was instructed in Natural Philosophy by Musschenbroek and Gravesande, who were the intimate friends of his father, and whose names will be ever illustrious in the annals of science. From these studies he was naturally led to the pursuit of Medicine, of which the elementary branches have so close an alliance with the physical sciences; and having entered the university of Leyden, became the pupil of Gaubius, Van Rooyen, and the elder

Camper.

Albinus; for Boerhaave was, by this time, incapacitated by the infirmities of age from continuing his exertions as public teacher in the university. Camper earned the first fruits of his academical labours by receiving, in 1746, the degree of Doctor in Philosophy and Medicine; on which occasion he published two dissertations; the one *De Visu*, the other *De oculi quibusdam partibus*, which are mentioned with commendation by Baldinger, in his *Biography of Living Physicians*, and which have been preserved by Haller. In the former he illustrates and defends Smith's *Theory of Vision*, and in the latter describes and gives plates of Petit's *Canal in the Eyes of different Animals*.

The acquaintance he had formed at college with several foreigners of merit, had long inspired him with a desire of travelling, and of gratifying his thirst for knowledge, by visiting different countries, and conversing with men distinguished for their attainments in the several branches of science. But the declining health of his parents, who were now advanced in years, and required the continual presence and kindest attentions of their son, long prevented him from accomplishing his wishes. Their death, however, which happened in 1748, released him from duties, which he had the consolation of reflecting had been so piously discharged; and he soon after, at the age of twenty-six, embarked for England. In London he met with the celebrated physicians Mead, Pringle, and Pitcairn, with whom he became acquainted. He pursued his medical studies under Hunter, Sharp, Smellie, and Wmchester, and indulged his taste for natural history, by examining diligently the cabinets of Hans Sloane and Collinson, and the collections of Hill and Catesby. He studied Botany under Elliot, and Astronomy under Short; and was instructed in the use of the microscope by Baker, who was at that time applying this instrument with so much success to objects of natural history. He seemed determined to suffer no opportunity of amassing a store of useful knowledge to escape him; and although his views embraced a wide range of subjects, he was never satisfied with a superficial glance, nor trusted to the reports of others, when there was a possibility of seeing with his own eyes the objects of his curiosity. His attention was particularly directed to the mechanical arts; he visited the principal manufactories, and was indefatigable in collecting instructions from artists of eminence in every department; and his eager curiosity even extended to the details of naval architecture, to the study of which he devoted a considerable portion of time. He was in the habit, during all his travels, of making minutes of every thing he saw and learned; and his happy facility in the employment of the pencil, enabled him to take sketches on the spot of every object of which a delineation could be useful. Knowledge thus derived from personal observation is the more valuable, as it is more strongly impressed on the memory, and as it is less liable to inaccuracy, and less likely to be tinged with prejudice, or distorted by the medium through which it is received. He still cultivated his taste for painting, and acquired much practical skill in the art

Camper. of engraving. After remaining about a year in London, and visiting the universities of Oxford and Cambridge, he proceeded to Paris, and devoted two months to the inspection of the principal public establishments in that capital. He then travelled onwards to Lyons and Geneva: but the prosecution of his journey in the direction of Italy was stopped by the intelligence he received of his being appointed Professor in Philosophy, Medicine, and Surgery, at Franeker, in Friseland; and he returned to Holland by Switzerland, and the banks of the Rhine, visiting, as he passed through Basle, the great Berneulli, and examining, in the library of that city, the writings of Erasmus and the paintings of Holbein. The itinerary which he kept of his journey contains a great number of valuable remarks on agriculture and geology, and showed how well he was gifted with the talent for observation.

In consequence of a severe illness with which he was attacked in 1749, he was obliged to defer entering upon the duties of his new Professorship till the autumn of the following year, when, in conformity with the custom on these occasions, he pronounced a public inaugural discourse, choosing as his subject *De Mundo Optimo*. About the same period he was elected a Fellow of the Royal Society of London.

He had resped so much advantage by his residence in England, and was so much attached to its inhabitants, and full of admiration for the great public establishments of that country, that he returned there during the vacation of 1753, and resumed his various pursuits, both medical and scientific, with unabated ardour. Among other objects, his attention was much directed to the method of inoculating for the small-pox, the practice of which was as yet confined to England. On his return to Franeker he resumed his lectures, which were every year more numerously attended, and gained him such increasing celebrity, that he was soon ranked as one of the ablest men of science in Holland. In 1755, he was appointed Professor of Anatomy and Surgery at the Athenæum of Amsterdam, and came, in consequence, to settle in that city, which was then the seat of opulence and learning. According to custom, he pronounced two inaugural discourses, the first, *De Anatomie in omnibus scientiis usu*; and the second, *De certo in Medicina*. In 1756, he married the widow of the Burgomaster of Harlingen.

After continuing six years in Amsterdam, his avocations were so multiplied and fatiguing, that he yielded to the strong desire which Mrs Camper had long entertained of retiring to Friseland; and once more took up his abode at his country house near Franeker. He, of course, resigned his Professorship at Amsterdam; but was allowed to retain the title of Honorary Professor of that Academy. His principal work, during the time he had held that chair, was the first volume of his *Demonstrationes Anatomico-Pathologicae*. But the leisure he now enjoyed in his retirement in Friseland, allowed him to devote his whole time to science; and the second volume of the same work made its appearance in 1762, together with several other publications, of which notice will be taken in the sequel.

Camper. Two years thus gilded by rapidly in the country, when he was again called to the active duties of an academical life, by the appointment which was conferred upon him of Professor of Medicine, Surgery, and Anatomy, in the University of Groningen. The proximity of this city to his present habitation, the natural activity of his mind, and a conscientious desire of being useful to the community, concurred with the love of fame, which retirement had not extinguished, in inducing him to undertake the office which he was now so honourably called upon to discharge. He accordingly established himself and his family at Groningen, and, at his inauguration as professor, delivered a discourse, *De admirabili analogie inter stirpes et animalia*. The great interest which he took in the improvement of agriculture, led to the establishment, under his auspices, of a society for the purpose of conducting experiments in this important art. To this society Camper was nominated Secretary. He bestowed much pains in investigating the nature of an epidemic disorder, which prevailed extensively among the cattle of Holland, and in devising the best means of diminishing its ravages. He made these the subject of several lectures, which he read, in 1769, to the Academy of Groningen; and his proposed method of inoculating the disorder, with a view of disarming it of its virulence, appears to have effectually succeeded in those districts where it was adopted. He was also much occupied, at this period, with researches in Natural History; and made a variety of important discoveries in Comparative Anatomy, of which we shall afterwards give a brief account.

The ten years that he spent at Groningen were esteemed by Camper the happiest, at the same time that they were the most laborious, of his life; and he probably would never have quitted a situation in every respect so congenial to his taste, or the circle of friends he had formed there, by whom his talents were well appreciated, and in whose approbation he found the reward of his exertions, if the wishes of his wife, and his own anxiety to superintend the education of his family, had not induced him to make the sacrifice of all these enjoyments, and once more remove to Franeker Academy, at which his sons were to be placed. He continued, nevertheless, steadily to prosecute his various philosophical and medical researches until the year 1776, when he sustained a heavy stroke of affliction in the death of his wife, in whom his affections had been centered during a union of twenty years, and whose domestic virtues, and exemplary attention to her children, had secured her the esteem and respect of all who knew her. As the most efficacious mode of soothing his grief, he determined upon varying the scene, and making occasional excursions to the neighbouring parts of the Continent. He accordingly visited all the cities that offered objects of attraction in the sciences or the fine arts; and after gratifying his taste for painting by the sight of the masterpieces of Rubens, Vandyke, and of other Painters of the Flemish School, proceeded, in search of amusement and instruction, to pay another visit to Paris. Here he enjoyed the society of Franklin, Marmontel, Di-

Camper. derot, Daubenton, Portal, and other distinguished characters in the literary and scientific world. Returning to his own country, with recruited spirits, he applied himself with fresh ardour to his favourite pursuits, and, aiming at more comprehensive views of the animal kingdom, occupied himself in pursuing the analogies which connect its several departments, and in tracing the successive links of that extended chain, by which the different orders of beings are united in one continued series of gradation. A tour through Germany, at a later period of his life, brought him acquainted with many treasures in Natural History, with which that country abounds. The anatomical preparations of Kerkringius, and the observatory of Tycho Brahe at Hamburgh; the collections of Natural History of Taube and Desrogués at Zell, and the superb cabinet of antiquities of the Count Walmoden at Hanover, particularly attracted his attention; and he explored with the eye of a geologist the volcanic district of Cassel. He formed also the acquaintance of Zimmerman, Soemmerring, and other eminent physicians. The following year he visited Prussia, and was presented to the great Frederick, who received him at Potsdam, with much affability and respect, conversing with him for a long time on the subject of the fine arts; and, on his return, had the honour of spending two days with the brother of the king, Prince Henry of Prussia, at Rhynsburg.

In 1785, Camper was chosen Member of the Royal Academy of Sciences at Paris, an honour which was the more highly prized, as the number of foreigners on whom it was conferred was limited to eight. In the same year, he paid a fourth visit to England, a country for which he had always shown a strong partiality, and was again gratified with the society of the numerous friends he had left there, and of others whose acquaintance he then for the first time made.

His literary and philosophical occupations, numerous and important as they were, did not preclude him from taking an active part in the political concerns of his country. In 1768, he was returned as deputy in the Assembly of the province of Friesland; and in 1776, appeared there as deputy for Idaarderadeel. He persuaded the Assembly to reject a proposal for the restoration of the maritime dikes of that province. In 1783, on the recommendation of the Stadtholder, he was nominated one of the Council of State of the United Provinces, and was of course obliged to reside at the Hague. During the revolution which soon after occurred in Holland, he remained faithfully attached to the party of the Stadtholder; without, however, yielding his unqualified approbation to all their measures. The triumph of his own party was even accompanied with circumstances which gave him much concern, and embittered the latter period of his life. He died in 1789, of a violent pleurisy, on the 7th of April: and his remains were deposited in the tomb of his ancestors, in the Church of St Peter at Leyden.

To a mind enriched with vast stores of knowledge, and adorned with a taste at once elegant and refined, Camper united the most benevolent affections, and possessed all the virtues of domestic and social life.

Camper. His conduct in the several relations of son, of husband, and of father, was in all respects exemplary. His manners were remarkably placid, and bespoke that habitual equanimity, which was the characteristic quality of his temper, and which, amidst strong sensibility to the affections of humanity, he constantly studied to preserve. Nature had bestowed upon him a dignified and graceful form, and a remarkably animated and expressive countenance. His voice, which was sonorous and flexible, was excellently adapted for public speaking. He had a singular facility in acquiring languages; and spoke fluently Latin, English, French, and German; and had, besides, attained a competent knowledge of Greek and of Italian.

Few men have received, during their lives, so many honourable marks of literary distinction as Camper. Besides those which have been already mentioned, he was chosen Member of the Academies of Petersburg, Berlin, Edinburgh, Manchester, Thoulouse, Gottingen, Harlem, Rotterdam, and Flushing; and was Foreign Associate of the Royal Society of Medicine at Paris. He obtained the prize of the Academy of Harlem, for his *Memoir on the Physical Education of Children*. His *Researches on Specific Remedies* gained him the prize of the Academy of Sciences of Dijon; his *Observations on Inoculation* that of the Academy of Thoulouse; and his *Memoir on Chronic Diseases of the Chest* that of the Academy of Lyons. The Royal Academy of Surgery voted him three prizes for his *Memoirs on the Influence of Different Circumstances in Regimen on the Treatment of Surgical Diseases*. To specify in detail the several subjects on which he has written, would be to extend this article to too great a length. We shall, therefore, content ourselves with enumerating those works which are of most importance; and, instead of reciting them in the order of their publication, shall arrange them according to the subjects to which they relate. His principal labours were bestowed on Comparative Anatomy and Physiology, and his discoveries in this wide field of research are numerous and important. A posthumous collection of his works on these subjects appeared at Paris in 1803, in 3 vols. 8vo, with a folio atlas of plates, under the title of *Œuvres de Pierre Camper, qui ont pour objet l'Histoire Naturelle, la Physiologie, et l'Anatomie Comparée*; to which is prefixed an Essay on his Life and Writings, by his son, and two eulogiums, one by Vicq d'Azyr, and the other by Condorcet. They contain his *Dissection and Natural History of the Orang-outang, and other Species of Apes*. He examines especially the peculiarities in the structure of the organ of voice of those animals, which deprive them of the power of uttering articulate sounds, and which alone would place an immense interval between them and the human species. His anatomical description of the two-horned rhinoceros, of the rein-deer, and of the elephant, are the subjects of separate dissertations; as also his researches on the structure of the great bones of birds, and the manner in which atmospheric air is introduced into them (of which the discovery was made by Camper, prior to the time at which Hunter published his observations on the same fact); on the

uper
li
mpo-
mea.

structure of the porpoise and the whale; on the classification of fishes, according to the system of Linnæus; on the anatomical structure of the organs of hearing in fishes, and of the blowing-holes of the cetacea; on the *dugon* of Buffon, and the *sirena lacerlina* of Linnæus, both of which he pronounces to belong to the class of fishes; on the generation of the *pipa*, or American toad; on the croaking of the male frog; on the petrifications found in the mountain of St Peter, near Maestricht, and the fossil bones of fish and other animals; on the analogies that may be traced between the several parts of the animal kingdom, especially in the structure of the human species, compared with those of quadrupeds, birds, and fishes; on the alteration of form in the human species produced by age; on the diversity of features which characterize different nations, and the mode of expressing these differences in delineating the human figure; on the mode in which the passions are indicated by the countenance; on the *beau physique*, or the beauty of forms; and on the analogy between plants and animals. In the practical branches of Medicine, he has written observations on the inoculation of the small pox, founded on experiment; on the theory and treatment of chronic diseases of the lungs, and a historical inquiry into the principal methods of cure employed by the ancients and moderns in these disorders; on the nature, employment, and mode of operation of remedies termed specifics; on the nature, causes, and treatment of dropsy, and the different indications of cure derived from the symptoms; on the nature of cancer, and on the signs denoting those of the breast that do not admit of cure; on the herniæ incident to new-born children, &c.; on ulcers in the urethra and prolapsus ani; on the fracture of the patella; on the callus of fractured bones; on lithotomy, and especially on the method of performing that operation at two different times, according to the plan of the celebrated Franco; on the construction of bandages for herniæ; on bandages in general; on the abuse of ointments and plasters, in the treatment of ulcers, and on improved methods of managing them; on the noxious effects attending the admission of air into the body, and the influence of this principle on the treatment of surgical diseases. In the department of Midwifery, he has written a letter to Dr Van Gescher on the utility of the section of the *symphysis pubis* in laborious labours, and observations on the use of the lever of Roonhuysen in difficult parturition. Several memoirs on the subject of infanticide, and the juridical questions connected with that subject, were published by him at Leenwarden. (w.)

CAMPOMANES (D. PEDRO RODRIGUES, COMTE DE), a Spanish Statesman, and Writer of great celebrity, particularly on subjects of Political Philosophy, was born in the Asturias towards the year 1710. We have sought in vain for biographical materials in regard to this eminent person, of whose life we can find no particulars but the scanty notices contained in the *Biographie Universelle*, and the Supplement to the last edition of the *Dictionnaire Universel*. From these works we learn that, in 1765 he was appointed

Campo-
manes.

by Charles III. Fiscal of the Royal and Supreme Council of Castille; that on the accession of Charles IV. in 1788 he was appointed President of this Council, and afterwards Minister of State; and that he was expelled from the Council, and deprived of all his employments, when Count Florida Blanca came into power. He was Director of the *Royal Academy of History*, and an honorary member of most of the other similar establishments in Europe. He supported his expulsion from office and power with firmness and dignity; and died at Madrid, according to the *Dictionnaire Universel*, in 1789, but according to the *Biographie Universelle*, not till after the commencement of the present century.

The number of his works, and the variety of subjects which they embrace, show him to have been a man of uncommon activity, as well as versatility of talent, while some of them display such a depth of political knowledge, and superiority to the prejudices of his country and age, as have ranked him in the first class of modern writers on Political Economy and Legislation. The following list contains abridged titles of his principal works, all of which, we believe, were published in the Spanish language, and none of them, so far as we know, has ever appeared in an English dress.

1. *Historical Dissertations on the Order of the Knights Templars*. Madrid, 1747.
2. *A Translation of the Periplus of Hanno, with Notes*. 1756. This translation was made from Hudson's edition of the *Periplus*, and the Notes contain a refutation of the objections urged by Dodwell against the authenticity of this celebrated Journal, which is now universally admitted to be one of the most curious relics of antiquity. The learning and ability which he displayed in support of it procured him an unsolicited place among the corresponding members of the French *Academy of Inscriptions and Belles Lettres*.
3. *A Geographical Account of the Kingdom of Portugal*. 1762.
4. *Two Memorials* relative to the means of regulating and employing *Gypsies* and *Vagrants*. 1763-4.
5. *A Memorial on the necessity of a Free Commerce in Grain*. 1764.
6. *Memorial on the provisioning of the city of Madrid*, drawn up and published by order of the Supreme Council. 1768, 2 vols. 8vo.
7. *Discourse on the Protection of Industry*. 1774, in 8vo.
8. *Discourse on the education of Artisans*. 8vo, 1775. In 1777 he gave to the world an *Appendix* to this work, containing a view of the causes which have led to the decline of arts and manufactures in Spain, in 4 vols. 8vo. Of these two great works, the *Discurso sobre el fomento de la industria popular*, and *Discurso sobre la educacion Popular de los Artesanos*, Dr Robertson speaks as follows: "Almost every point of importance with respect to interior police, taxation, agriculture, manufactures, and trade, domestic as well as foreign, is examined in the course of them; and there are not many authors, even in the nations most eminent for commercial knowledge, who have carried on their inquiries with more thorough knowledge of those various subjects, and a more perfect freedom from vulgar and national prejudices, or who have united more happily the calm researches of phi-

losophy, with the ardent zeal of a public-spirited citizen." (*History of America.*)

The above seem to be the chief productions of the pen of Campomanes; but, besides these, he was author of several other pieces on historical and literary subjects; and he published a complete edition of the voluminous works of Feyjoo, to which he prefixed an account of the life of that learned Benedictine.

CAMUS (CHARLES STEPHEN LOUIS), a mathematician and mechanic: born at Cressy en Brie, near Meaux, the 25th August 1699; son of Stephen Camus, a surgeon of that town, and Margaret Mailard.

His taste for practical mechanics was very early demonstrated by a singular ingenuity in the construction of a variety of little machines, with which he amused himself; and he soon felt so strongly the value of mathematical studies, that he urged his parents to find the means of sending him to a school where he might apply to them. In compliance with his wishes, he was placed, when he was little more than ten years old, at the College de Navarre, in Paris: and in two years he acquired knowledge enough to become an instructor of others, and to relieve his friends from all further expence in his education. He was assisted, in the pursuit of the higher departments of the mathematics, by the celebrated M. Varignon; and he particularly applied himself to civil and military architecture, and to astronomy.

1. The first result of his studies that was destined for the public eye, was an essay *On the Masts of Ships*, a subject which had been proposed in 1727 as a prize question by the Academy of Sciences. This essay was received with considerable approbation, and was inserted in the second volume of the *Collection of Prize Memoirs*: shortly after, the author was made an Adjunct, or Subassociate, of the Academy, in the department of Mechanics.

2. In 1728 he brought forwards a memoir on the *Living force* of bodies in motion, in which he concludes, from considering the actions of springs, and other similar powers, that its true measure is the product of the mass into the square of the velocity, as Leibnitz maintained: this product being also proportional to that of the force into the space through which it acts, while the momentum is proportional to the force and the time conjointly. In December 1730, M. Camus was appointed Professor of Geometry to the Academy of Architecture, and a few years afterwards he became Secretary to the same body.

3. The *Memoirs of the Academy* for 1732 contain a short paper on a *Problem proposed by M. Cramer*, respecting the determination of two curves bearing a particular relation to each other. It was the custom of the age to consider exercises of this sort as trials of strength, to which it was incumbent on all geometricians to submit, for the honour of the countries in which they lived, and of the societies to which they belonged. The author was elevated in 1738 to the rank of an Associate of the Academy,

together with Clairaut, over whom he even obtained some advantage in the ballot.

4. He communicated to the Academy, in the same year, a valuable paper on the *Teeth of Wheels*. Lahire had already laid the foundation of the investigation on its true basis, and had pointed out the use of different epicycloidal curves for the forms of the teeth of wheels in different circumstances: and M. Camus, in this essay, enters into some further inquiries, particularly with regard to the best proportions for the length of the teeth, and the comparative diameters of the wheels: a discussion for which his intimate acquaintance with the art of the clock-maker made him particularly well qualified. In 1736 he accompanied Maupertuis and Clairaut in the expedition to Lapland, for the measurement of a degree of the meridian; and he was enabled to render them very essential service, not only as a geometer and an astronomer, but also by his skill in various departments of the mechanical arts, which became particularly valuable in so remote a situation.

5. M. Camus directed his attention in 1738 to the well known but interesting mechanical phenomenon of a *Pistol ball piercing an open door*, without causing any very sensible motion in the door, and published a paper on the subject in the *Memoirs of the Academy*. He justly observes, that the effect of any force depends, not only on its magnitude, but also on the time for which it operates; and that though the impulse of the ball must tend to carry the door before it, with a force paramount to the resistance which it opposes to the ball, yet the time of the action of this force is too short to produce a sensible effect on the whole mass of the door. 6, 7. In 1739 he presented to the Academy two hydraulic memoirs, the one on *Water buckets*, the other on *Pumps*. In the latter he investigates the diameter of a valve, capable of transmitting the greatest quantity of water, within a given barrel; a valve which is too large not being at liberty to rise to a sufficient height.

8. He inserted in the *Memoirs* for 1740 a confutation of a *Mechanical fallacy*, which has misled many of the enthusiasts who have bewildered themselves in the search of a perpetual motion: demonstrating, that when a number of weights are caused to descend, in any imaginable paths, at a greater distance from the centre of a wheel than they ascend, the number of the weights descending at any one time must always be smaller than those of the weights ascending; and in such a proportion, as perfectly to compensate for the mechanical advantage apparently gained by the greater distance. In the following year he was received into the number of the Academicians, in the department of Geometry, on occasion of the resignation of M. Fontenelle.

9. He published also, in the *Memoirs* for 1741, an account of a *Gauging rule*, for measuring barrels of different forms, by simple inspection of the logarithmic scales engraved on it, observing only some easy rules for their adjustment, according to the general nature of the solid. 10. In 1746 he presented a Report, in conjunction with M. Hellot, on the *Length of the Standard Ell*, which was thought worthy of being inserted in the collection of the Academy.

Camus
Canada.

11. We find among the *Memoirs* for 1747 an *Essay* of M. Camus on the *Tangents of Curves* having several branches, crossing each other; which frequently require, for their determination, the use of fluxions of the higher orders, the first fluxions of the absciss and ordinate vanishing together. M. Saurin had before given a similar solution of the problem, but had not attempted to explain the metaphysical ground, upon which the apparent paradox is reconciled to the general principles of the differential method.

12. M. Camus also assisted in several determinations and reports which were referred at various times to committees of the Academy; and particularly in the remeasurement of M. Picard's base from Villejuif to Juvisy, which was performed by eight members, and recorded in the *Memoirs* for 1754.

13. The latter years of his life were much occupied in various engagements connected with the offices of Examiner in the schools of the Royal Engineers and in that of the Artillery, to which he was nominated by the King. He undertook, for the advantage of the students in these schools, the laborious task of reducing into a uniform system a complete course of mathematical study, in which the geometrical method was as much as possible observed, and which is considered as highly creditable to his talents and exertions: it was entitled *Cours des Mathématiques*, 4 vols. 8vo. 14. He also published an *Elementary work on Arithmetic*.

In person M. Camus was tall; his countenance was agreeable; his manners firm, and occasionally somewhat warm; but he was far from being either morose or vindictive. He was elected a foreign member of the Royal Society of London in January 1764. He married, in 1733, Mad^{lle}. M. A. M. Fourrier, and had four daughters, the eldest of whom was married to M. Pagin; the others died young. His last illness was supposed to have originated from a cold, taken in a professional journey, during the hard winter of 1766; and to have been aggravated by affliction for the loss of his surviving daughter: he died a few months after her, on the 4th May 1768. He left a variety of manuscripts, demonstrative of his habitual diligence, and of the extent of his researches; but not deemed of sufficient importance to meet the hazards of posthumous publication. (*Hist. Acad. Par.* 1768. P. 144.) (M. E.)

CANADA. In the *Encyclopædia* will be found an account of the settlement and early history of Canada, with other particulars relative to the nature and productions of the country. At present we propose to add such further information as we have been enabled to collect from the works of recent travellers.

In the year 1791, the territory formerly distinguished by the general name of Canada, was divided, by an act of the British Parliament, into the two provinces of Upper and Lower Canada. These are comprehended within the 61° and 81° of west

Canada.

longitude from London, and between 42° 30' and 52° north latitude; and are computed to extend from east to west about 1400 miles, and from north to south from 200 to 400 miles.

The province of Lower Canada lies between 45° and 52° of north latitude, and between the 63° and 81° of west longitude. On the north it is bounded by the territory of East Maine; on the east by the Gulf of St Lawrence, the river St John, and part of the Labrador coast, now annexed to the government of Newfoundland; on the south, by New Brunswick and the territories of the United States, namely, the district of Maine, the province of New Hampshire, the state of Vermont, and the state of New York; on the west, by a line which separates it from Upper Canada, commencing at a stone boundary on the north bank of the Lake St Francis, in St Lawrence river, thence north to Ottawa river, which it ascends to its source in Lake Temiscaming, and from thence due north, till it strikes the boundary-line of Hudson's Bay, including all the territory to the westward and southward, commonly known under the general name of Canada. This province is divided into the districts of Montreal, Three Rivers, Quebec, and Gaspé, which by proclamation of the Government were, in 1792, subdivided into the following twenty-one counties, viz. Bedford, Buckingham, Cornwallis, Devon, Dorchester, Eppingham, Gaspé, Hampshire, Hertford, Huntingdon, Kent, Leinster, Montreal, St Maurice, Northumberland, Orleans, Quebec, Richlieu, Surrey, Warwick, and York. The minor divisions are, 1st, The seignories, or the original grants of the French Government under the feudal system, which, in the year 1721, were again partitioned out into parishes. The limits of these last, however, have not been very strictly adhered to, portions of ancient parishes having been from time to time constituted into new ones. 2^d, The townships or grants of land made by the English Government since the year 1796, in free and common soccage.

The following are the boundaries of Upper Canada: On the east, it is bounded, since the year 1791, by Lower Canada; on the north-east, by the Grand or Ottawa river, which is the common boundary between it and the lower province; on the north, by the territories of the Hudson's Bay Company; on the south and south-east, by the United States of America, although the common frontier between these two states is far from being well defined. It is merely an imaginary line, beginning at the village of St Regis on the St Lawrence, in the 45th° of north latitude, passing up the middle of this river, through Lake Ontario, the Niagara river, and Lake Erie, and continuing thence through the middle of the water-communication into Lakes Huron and Superior, along the middle of the chain of lakes which leads to the Lake of the Woods, and from thence due west to the river Mississippi.* The treaty of 1815 provides for the revision of this boundary-line. On

Upper Ca-
nada.

* This is the boundary fixed by the treaty of 1783, when the country was little known, and it is therefore erroneous; the Lake of the Woods being to the north of the sources of the Mississippi. A line drawn due west from this lake would never strike the Mississippi.

Canada. the west and north-west, no limits have been assigned; and Upper Canada may be supposed, therefore, to extend, in this direction, as far as the Pacific and Northern Oceans.

Upper Canada is divided into eight districts, namely,

Eastern,
Johnstown,
Midland,
Newcastle,

The Home,
Niagara,
London, and
The Western.

These again are subdivided into twenty-three counties, namely,

Glengary,
Stormont,
Dundas,
Prescott,
Russel,
Grenville,
Leeds,
Carleton,
Frontenac,
Lenox,
Addington,
Hastings,

Prince Edward,
Northumberland,
Durham,
York,
Norfolk,
Oxford,
Middlesex,
Lincoln,
Haldimand,
Kent, and
Essex.

These contain 159 townships, exclusive of Indian lands, and certain other portions that are reserved for the Crown, and the maintenance of the Protestant clergy. The quantity of land in each township is computed by Bouchette, in his valuable and elaborate work on Canada, to amount, on an average, to 61,600 acres, making the whole amount to 9,694,400 acres; of which 3,000,000 of acres are granted in feu and common soccage, 2,769,828, are reserved for the Crown and clergy, and 3,924,572 still remain to be granted.

General
Aspect of
the Coun-
try.

The country of Canada is intersected by mountainous ridges, which extend from the coast far into the interior, and between these lie extensive valleys, which are generally pleasant and fertile. On the southern shore of the St Lawrence, a ridge of heights rises near the eastern extremity of Lower Canada, which runs close to the river for upwards of 100 miles, and forms its rugged banks as far as Cape Tourment, about 30 miles below Quebec. Here the ridge, taking a direction west south-west, terminates on the river Ottawa, about 38 leagues above its confluence with the St Lawrence; extending westward from Cape Tourment along the course of the river about 300 miles. The tract of country lying between it and the St Lawrence, which may be estimated at from 15 to 30 miles in breadth, is beautifully picturesque, well watered, and level. Towards the westward, more especially, it may be considered, both in respect to population, soil, and skilful cultivation, as the choicest part of the province.

That part of Canada which lies on the north side of this ridge, is comprehended within the Ottawa river on the north-west, the 81st parallel of west longitude, and the 52d of north latitude. It is intersected by another and higher range of mountains, which runs into the interior in a north-west direction, at the distance of about 200 miles from the former

ridge, and which forms the height of land by which the tributary streams of the St Lawrence are divided from those that fall into Hudson's Bay. Of this extensive wilderness, which has been but imperfectly explored, all that we know is, that it is covered with immense forests, whose dreary solitudes are only interrupted by hunting parties of wandering savages.

On the south side of the river St Lawrence, a ridge commences nearly 100 miles below Quebec, taking a south-west direction; and, opposite to this city, it is about 10 leagues distant from the river. The intervening country is a fertile and well-cultivated level, with several insulated hills, or rather rocks, of a singular form, and thinly covered with small trees near their summits. The same chain, continuing in a south-west direction, crosses the boundary-line between Canada and the United States to the west of Lake Memphremagog, and proceeds in the same course until it meets with the Hudson river. The tract between this ridge and the St Lawrence, with the exception of some occasional ridges, is nearly level; and, from the richness of its soil, is covered with populous and flourishing settlements.

Beyond this ridge, at about the distance of 50 miles, is another and a higher ridge, generally denominated the Land's Height, as it divides the tributary streams of the St Lawrence from those which flow towards the Atlantic Ocean, and its summit is also supposed to constitute the boundary-line between the territories of Great Britain and the United States. This range of mountains commences near Cape Rosier, in the Gulf of St Lawrence, and, running into the interior in a direction nearly parallel with the course of the river, and with the former chain, it terminates upon the eastern branch of Connecticut river, being in length nearly 400 miles. The country lying between these two ridges, varies in its quality and fruitfulness, according to its peculiar situation. From the 45th degree of north latitude, which is the boundary-line between Canada and the United States, to the river Chaudiere, within a few miles of Quebec, there is a tract of excellent and fertile land, divided mostly into townships, many of which are settled and under cultivation. This part of the country, both from its luxuriant soil, and from the great advantage of its being contiguous to the United States, and its comprehending the main roads and principal points of communication between the two territories, will probably become the most flourishing portion of the province. From the river Chaudiere eastward to Lake Temiscouata, the land is broken, irregular, and of an indifferent quality; interspersed, however, with some good and productive tracts, of which the returns would amply repay the expences of cultivation.

From Lake Temiscouata eastward to Cape Rosier, in the Gulf of St Lawrence, the country has been but partially explored. But it appears generally to be of a rugged and mountainous character, and such parts of it as are known exhibit an appearance of sterility which holds out no encouragement to the labours of the farmer. On the banks of the St Lawrence, however, some fertile spots are to be found, on which settlements might be established with advan-

Canada. tage. On the south side of the ridge, down to the shores of Gaspé and Chaleur Bay, the country is generally barren and mountainous, interspersed with occasional spots of excellent land, some of which, especially those on the shores of Chaleur Bay, are well settled. They contain about 3000 inhabitants, most of whom, being employed in the fisheries, bestow comparatively little attention on agriculture.

That portion of Upper Canada which has been laid out into townships, extends from its eastern frontier along the north shore of the river St Lawrence, Lake Ontario, Lake Erie, Lake St Clair, and the communication between it and Lake Huron, in length about 570 miles, and its breadth towards the north varies from 40 to 50 miles. Through the whole of this track the soil is excellent, and is not exceeded by any other part of the American Continent. It generally consists of a fine dark loam, mixed with a rich vegetable mould; but it is so happily varied as to present situations adapted to every species of produce. For about 170 miles from the eastern frontier of the province to the head of the Bay of Quinté, on Lake Ontario, the land is spread out into an almost uniform level of great beauty, which rises only a few feet from the bank of the St Lawrence. It is well watered in almost every direction by numerous streams, which are generally navigable for boats and canoes, and which, at the same time, present the most desirable situations for the erection of machinery. From the Bay of Quinté, about 40 miles from the eastern shores of Lake Ontario to its western extremity, runs a longitudinal ridge of no great elevation, and of inconsiderable breadth. Another ridge, called the Queenstown Heights, extends eastward along the southern shores of Lake Ontario, between these and Lake Erie, into the State of New York. This range never rises in any part more than 160 yards above the level of the lake. The country which lies between the two lakes of Ontario and Erie, and which extends round the western extremity of Lake Ontario to the Bay of Quinté, comprehending the Newcastle, the Home, and the Niagara districts, or nearly one-third of that portion of the province which has been surveyed, and laid out into townships, is watered by a number both of large and small streams. The land throughout is uncommonly rich and fertile, and already contains a number of flourishing settlements.

The remaining part of the tract we have been describing, which extends along the southern shores of Lake Erie, from the river Ouse to the Lake and River of St Clair, is a complete level, abounding in the most advantageous situations for settlements; and those places which are already occupied and under tillage, equal any part of either province, for the plentiful crops and thriving farms with which they abound. That portion of the country which lies between Lake Erie and Lake St Clair is, perhaps, the most delightful in the whole province. The fertility of the soil,—the diversified and luxuriant scene which everywhere opens to the view,—the excellent fish which abound in the rivers, and the profusion of game in the woods, combine to attract a continual supply of new settlers to this highly favoured tract.

Canada. Beyond these cultivated parts of Upper Canada, there are large tracts of land, stretching far to the northward, covered with immense forests, the haunt of wild animals and of wandering savages. But these regions, though they have never been explored by the Europeans, are known to spread out into valleys of a rich and fertile soil, more especially in the country skirting the south-west shore of the Ottawa river. They are also watered by many streams, some of a large size, which flow both into Lake Huron, and into the Ottawa river. The course of these rivers is not, however, sufficiently known, to be traced with accuracy on the map. In those unexplored countries all sorts of timber are found in the greatest profusion. The oak, beech, walnut, ash, hickory, maple, elm, pine, sycamore, birch, and many other sorts, grow to the largest dimensions, which is the best proof of the fertility and vigour of the soil in which they have taken root.

The rivers and lakes of Canada are stamped with Rivers, a peculiar character of grandeur. The great river St Lawrence issues from Lake Superior, and flowing successively through Lakes Huron, Erie, and Ontario, falls into the ocean after a course of 2000 miles. Its course is through a long and narrow valley, in which, also, are contained the great lakes from which it derives its ample stream. This valley seems to have taken the form of the immense collection of waters of which it is the depository; it is closely encompassed on every side, except on that through which the river makes its way to the sea, by different ranges of mountains, which completely encircle the great lakes at the distance, in some points, of not more than sixty miles, and shutting them up from the interior, form the dividing ridge between the tributary streams of the St Lawrence, and those which flow north and south into Hudson's Bay and the Mississippi. The prodigious volume of water which the St Lawrence rolls into the ocean, and the extent to which it is navigable, give it the pre-eminence over all the other great rivers of the American Continent. Its breadth, at its mouth, may be reckoned 90 miles, and at Saguenay river, 260 miles higher up, it is still 18 miles broad. It is navigable with safety for ships of the line 400 miles from its mouth, and, to Montreal, 160 miles further, it is navigable, with very little difficulty, for ships of 600 tons burden. For vessels of a larger size the navigation is intricate and dangerous. The St Lawrence is diversified by numerous islands, and its shores alternately present the pleasing view of flourishing settlements, and of sublime and picturesque scenery.

The tract of country which the St Lawrence drains of its waters, is confined, both on the north, and more especially on the south, by ranges of mountains which run along its whole extent; so that there is no adequate space for the formation of such immense tributary rivers as pour their waters into the Amazons, the Plata, or the Mississippi. It will, accordingly, be found that the main stream of the St Lawrence is not increased by such vast accessions from the tributary waters of the territory through which it flows, as these last mentioned rivers. The

Canada. principal rivers which it receives from the north, are the Ottawa, the Masquinongé, the St Maurice, the St Ann, the Jacques Cartier, the Saguenay, and the Manicouagan. From the south, it receives the Salmon river, the Chateaugay, the Chambly or Richlieu, the Yamaska, the St Francis, the Becancour, the Du Chene, Chaudiere, and Du Loup. Of these, the Ottawa and Saguenay are important rivers, and bring a great accession to the stream of the St Lawrence. The Saguenay is a broad, deep, and uncommonly rapid river. At its mouth it is only one mile broad, but is said to be of unfathomable depth, attempts having been made to find the bottom with 500 fathoms of line, but without effect. About two miles higher it has been found to be from 180 to 140 fathoms deep. The Ottawa is also a large and important river. It has its rise from several lakes in Upper Canada, and, rushing over a bed of remarkable declivity, falls into the St Lawrence a few miles above Montreal.

Lakes.

No country in the world contains such immense depositories of fresh water as Canada. Its lakes are not only numerous, but they are unequalled in magnitude by those of any other country in the world. Lake Superior, which is of a triangular form, is 381 miles in length, and 161 broad. Its circumference is above 1100 miles, and it is equally remarkable for the transparency of its waters and for their extraordinary depth. Lake Huron yields but little, in point of extent, to Lake Superior. Its greatest length from west to east is 218 miles; at its western extremity it is less than 100 miles, and at about 100 miles from its eastern shore it is scarcely 60 miles broad; but near the centre it extends southward to the breadth of 180 miles. Its circumference, measuring all the bendings of the coast, is about 812 miles. At the western angle of Lake Huron is Lake Michigan, which is 262 miles in length by 55 in breadth, and whose circumference is 731 miles. Lake Erie, which is connected with Lake Huron by the river Detroit, extends from south-west to north-east 231 miles. It is 63½ miles in breadth where it is broadest, and is 658 miles in circumference. From the north-east extremity of Lake Erie, the communication to Lake Ontario is by the Niagara river, and is 36 miles in length. This lake is 171 miles in length, its greatest breadth is 59½, and its circumference is 467 miles. In the interior, the country is covered with numerous smaller lakes, which are so connected, that, by the help of short pontages, and other expedients, a navigable communication, by means of canoes, is carried to the Lake of the Woods, Lake Winnipeg, and onwards to the distance of several thousand miles in the remote regions of the north-west country.

Climate and Seasons.

In Canada, the opposite extremes of heat and cold are felt in all their excess. The greatest heat experienced during the summer is from 96 to 102 degrees of Fahrenheit in the shade; but the usual summer heat varies from 75 to 80. In the winter, the mercury sometimes sinks to 31°, and it has even been known to fall so low as 36° below 0. It never continues, however, above one or two days at these extremes, and it is not above once or twice in a sea-

son that this excessive cold is felt. The medium temperature of winter may be estimated, in general, to be from 20 degrees above to 25 degrees below 0. The pure air and cloudless sky, which always accompany this intense frost, make it both pleasant and healthy, and render its effects on the human body much less severe than when the atmosphere is loaded with vapours. In the vicinity of the sea, towards the eastern coast of Lower Canada, fogs are frequently brought from the gulf of Lawrence, by the easterly wind. But to the westward they seldom prevail, and even at Quebec they are almost unknown. In Canada, the spring, summer, and autumn are comprehended in five months, from May to September. The rest of the year may be said to consist wholly of winter. The summer commences in May, and ends with September. In October, frost begins to be felt, although during the day, the rays of the sun still keep the weather tolerably warm. In the succeeding month of November, the frost increases in rigour, and one snow storm succeeds another, until the whole face of the country is covered, and the eye looks in vain for one solitary spot of verdure whereon to rest. These storms are generally accompanied by a violent tempest of wind, which, driving along the snow with immense velocity, renders them tenfold more gloomy and terrific. The most severe snow storms occur in November. They generally come from the north-east, from the frozen regions of Hudson's Bay and Labrador. This gloomy and disagreeable weather frequently continues to the middle or latter end of December, when the atmosphere clears; an intense frost succeeds—the sky becomes serene, pure, and frosty, and of a bright azure hue, and this cold and clear weather generally lasts till the month of May. The snow covers the ground to the depth of several feet, so that wheel-carriages can no longer be used. Their place is supplied by *carioles*, a sort of sledges, which, being placed on iron-runners, resembling in their form the irons of a pair of skais, pass over the hardened snow without sinking deep. Those carriages are generally light open vehicles, drawn by one horse, to which the snow, after it is trodden for some time, and hardened by the frost, offers very little resistance. In these vehicles, the Canadians travel in the most agreeable manner, and with inconceivable rapidity. So light is the draught, that the same horse will go in one day 80, and sometimes 90 miles, and the inhabitants of this cold climate always take advantage of the winter season, when they can travel so easily and expeditiously, to visit their friends who live at a distance. Covered *carioles* are sometimes used to protect the travellers from the weather. But, in general, open carriages are preferred.

About the beginning of December, all the small rivers are completely frozen over and covered with snow. Even the great river St Lawrence is arrested in its course, and from the beginning of December till the middle of April, the navigable communication is interrupted by the frost. During this period, the river from Quebec to Kingston, and between the great lakes, except the Niagara and the rapids, is wholly frozen over. The great lakes are

Canada. never entirely covered with ice; but it usually shuts up all the bays and inlets, and extends many miles towards the centre of those inland seas. In Lake Superior, which is furthest to the north, the ice extends 70 miles from the shore. It is seldom that the river is frozen over below Quebec. But the force of the tides is continually detaching the ice from its shores, and these immense masses are kept in such constant agitation that navigation is rendered quite impracticable. In some seasons, though rarely, the river is frozen completely over below Quebec; and this happens when large masses of ice come in contact, and fill the whole space between one side of the river and the other, in consequence of which the whole becomes stationary. If this takes place at neap tides, and in calm weather, the intense frost gives it solidity before it can be deranged by the rising tides; and when it has stood some days, it remains firm and immovable, till it is dissolved and broken up by the warmth of the April sun. When the river is frozen over, it is of great advantage, both to the inhabitants of Quebec, and to those of the adjacent country, as it affords an easy mode of transporting into the town all sorts of bulky commodities, such as fire-wood, and other produce. It thus reduces the price of those necessary articles in Quebec, while by diminishing the price of carriage, it opens to the produce of the most distant parts of the country, a quick and easy access to all the most eligible markets.

The snow begins to melt in April, and the thaw is so rapid that it is generally gone by the second or third week. Vegetation then resumes its suspended powers; the fields are clothed with verdure, and spring can scarcely be said to exist before summer is at hand. In Upper Canada, the winters are much shorter than in Lower Canada, nor is the cold so intense. The spring opens, and the labours of the farmer commence six weeks or two months earlier than in the neighbourhood of Quebec. The climate is not liable to the same extremes either of heat or cold, and the weather in autumn is usually favourable for securing all the late crops.

Commerce. The exports from Canada consist chiefly of oak and pine timber, deals, masts, and bowsprits, spars of all denominations, staves, pot and pearl ashes, peltry, wheat, flour-biscuit, Indian corn, pulse, salt provisions, furs of various descriptions, and other miscellaneous articles. The imports are wines, rum, sugar, molasses, coffee, tobacco, salt, coals, and all sorts of manufactured articles from Great Britain. The commerce of Canada has been progressively increasing since it became a British colony. In the year 1769, the value of produce exported amounted to L. 163,105; and it employed 70 vessels belonging to Great Britain and to her subjects in the different colonies of North America. Not more than twelve vessels were engaged at this period in the fisheries of the St Lawrence, and about six were sent to the West Indies. In the course of the next ten years, the trade appears to have greatly improved; and the number of vessels employed in 1775 was increased to 97, containing 10,841 tons. In the succeeding ten years, the number of vessels which entered the

Canada. St Lawrence was diminished to 57. But in the course of another period of ten years, about the year 1795, not less than 128 vessels were employed in the commerce of Canada. This increase was occasioned by the scarcity of grain which prevailed at that time in Britain, and in other countries of Europe; to supply the augmented demands from this quarter, there were exported from Canada in that year 395,000 bushels of wheat, 18,000 barrels of flour, and 20,000 cwts. of biscuit. The high prices which were procured for those necessary articles, gave a powerful stimulus to industry in all its branches, and by increasing the capital of the colony, gave it the means of carrying on a more extended commerce. The following is an account of its exports and imports:

For 1797, from Quebec, furs and other produce	L. 295,063
Wheat, biscuit, and flour	45,445
Oak and pine timber, planks and staves	32,144
Pot and pearl ashes	29,866
Fish, lumber, oil, &c. from Labrador and Gaspé	88,900
	<hr/>
	491,419
Imports from England of manufactured goods, and West India produce	338,214

In 1799 and the three following years, large exportations of grain took place. In 1802, 1,010,000 bushels of wheat, 38,000 barrels of flour, and 32,000 cwts. of biscuit were sent abroad; and the number of vessels engaged in the trade of the colony was 211, the aggregate burden of which amounted to 36,000 tons. Agriculture in Canada has since been greatly extended,—the surplus produce has of course increased, and we find the exports amounting for 1807 to L. 813,900; the imports to L. 467,294. In 1808 the exports had increased to L. 1,156,060, and the imports to L. 610,000.

The following is an account of the value of the exports to the British colonies in North America during four years previous to 1814:—

	British Produce.	Foreign.	Total
1810,	L.1,484,383	L.263,733	L.1,748,116
1811,	1,578,464	266,095	1,844,559
1812,	1,658,531	251,158	1,909,689
1813,	1,134,987	284,032	1,419,019

This includes the exports to Nova Scotia and Newfoundland, which being deducted, the annual value of the exports to Canada will not be found to amount to more than one million. Since the year 1808, therefore, its trade does not appear to have materially increased. In 1808, the number of vessels which cleared outwards from Britain to Canada was 179, and the number of arrivals from Canada, in the same year, was 202. In 1815, those which cleared outwards amounted only to 132, and those which entered inwards only to 138. This, however, is probably owing to accidental circumstances; since it cannot be doubted that as the interior ad-

Canada. vances in population and improvement, there will be a corresponding increase of external trade.

Population. For a long period after its original settlement, the colony of Canada was neglected by the court of France, and its administration was left, in a great measure, to the discretion of individuals. In 1668, it was raised to the dignity of a royal government, and from this period its governors were appointed by a regular commission from the king. Its inhabitants amounted to about 7000, who, possessing the advantages of a free trade and of regular government, began rapidly to increase; and, in 1714, their numbers had risen to 20,000. The colony would even have increased more rapidly, but, by the rashness of its governors, it was engaged in almost perpetual hostility with the native tribes, by whose continued incursions the attention of the settlers was distracted from agriculture to war. Under these disadvantages, however, its population had increased, in 1759, when it was conquered by the English, to 70,000. The conquest of a country must be regarded as a serious evil, even in circumstances the most favourable; and the revolution which took place, in consequence of this event, in the government and political institutions of Canada, tended, for some years, to retard its progress. The change of allegiance from one sovereign to another, was rendered as easy as possible to the inhabitants, by the lenient measures of the conquerors. Their laws were allowed to remain unaltered. They were secured in the undisturbed possession of their lands under their ancient tenures, and in the free possession of their religion. All religious property was respected, and every concession was made by the British Government in favour of the peculiar customs and manners of its new subjects. Under this judicious management, the country soon began to improve, and, in the year 1773, its population, including the new settlers in Upper Canada, who could not amount to above some thousands, had increased to 90,000. In 1814, according to a regular census, the province of Lower Canada contained 335,000 inhabitants. Of this number 235,000 may be reckoned native Canadians, descendants of the original French settlers. The remainder is composed of emigrants from various nations, chiefly English, Scotch, Irish, and American. In the year 1783, the settlers of Upper Canada were estimated at 10,000, of which the numerous frontier posts and garrisons constituted by far the greatest part. After this period, the number of settlers was augmented by a great accession of loyalists and disbanded soldiers, and by emigrants from the United States, and from Great Britain, so that in the year 1814 the inhabitants of the province had increased, according to the most accurate returns, to 95,000. Since the year 1798, the progress of this colony has been particularly rapid. In that year a solitary Indian wigwam stood where the town of York, the capital of Upper Canada, is now built. In the succeeding spring, the ground was marked out for the future metropolis of the country, and it now contains 2500 inhabitants, and is fast increasing. It is the residence of the chief officers of government, both civil and military, and affords many

of the more refined comforts and conveniences of life. A newspaper is printed once a week, and its markets are well supplied with every necessary from the adjacent lands, which are in a high state of cultivation. The other towns of Upper Canada are Kingston, Johnstown, and Cornwall. The two latter contain only sixty or seventy houses, built of wood. The town of Kingston was founded in 1784, and it now presents a front of nearly three quarters of a mile in length, and extending in breadth about 600 yards. It contains 370 houses, and the streets are regularly planned, crossing each other at right angles, though they are not paved.

At the time when Canada was conquered by Britain, the lands throughout the country were universally held by feudal tenures, all of which being confirmed by the British Government, still remain in force. But the townships and tracts subsequently disposed of, have been, with two or three exceptions, granted in free and common soccage. Under the French Government, the lands were held immediately from the King, either *en fief* or *en roture*; each proprietor being bound to render homage to the sovereign, on his accession to the seigniorial property. The revenues of the seigneurs arise from various sources. They are entitled to certain fines from their vassals, which are paid on the alienation of any part of the property. In the event of a sale, a sum of money equal to a twelfth part of the price, is payable to the seignior, and he has also the right, within forty days after the sale, to take the property sold at the highest price offered,—a right, however, which is seldom exercised. In the event of new lands being granted, a fifth part of the whole purchase money is payable to the seigneur, which, if paid immediately, entitles the purchaser to a deduction of two-thirds of the fine. The vassals are also bound to grind their corn at the lord's mill, and this condition is found on many occasions to be exceedingly irksome. In a large seignior, for example, there may not be more than one mill; and though it should be ten miles distant from the tenant's farm, and although he might have his corn ground on better terms at some adjoining mill, he is, nevertheless, bound to carry it to the seignior's mill, under a heavy penalty. Another evil of these seigniorial rights is, that they are by no means well defined, and that the vassal is, in consequence, subjected to exorbitant and unjust demands, when the superior happens to be of a rapacious disposition. In the provincial assembly, the propriety of setting bounds to these undefined privileges has been frequently urged by the English members. But the French party, attached to old habits, which they found conducive to their interest, have hitherto strenuously and successfully resisted any alteration of the established laws. The seignior is entitled to receive a tith of the produce of all the fisheries which are established within the bounds of his seignior. He has also the privilege of selling the timber which grows in any part of his seignior, for the purpose of erecting mills, repairing roads, or constructing new ones, or for any other purpose of general utility. Many proprietors of seigniories have acquired wealth from these revenues, as the sales

Canada. and transfers of landed property have of late years become numerous.

Lands held by Roman Catholics, under any of the aforementioned tenures, are still further subject to the payment of one twenty-sixth part of all the grain produced upon them, for the maintenance of their curates, and to occasional assessments for building and repairing churches. The lands of the province, which are not held under these tenures, are subjected to a reservation out of the produce of two-sevenths, one of which goes to the Crown, and the other is set apart for the maintenance of the Protestant clergy.

was and vern- nt.

The laws of England, both civil and criminal, were introduced into Canada after its conquest in 1759; and the criminal code of Britain, which freed the Canadians from the tyrannical modes of procedure to which they were formerly exposed, was generally considered as a most important improvement. But the civil code of England was not received with equal satisfaction. The inhabitants were attached by habit and prejudice to the ancient system by which property was regulated; and, by the act of 1775, therefore, that system was restored. The government of the country was, at the same time, vested in a council, composed of certain individuals, chosen by the sovereign. In 1792, by the 31st Geo. III., all the advantages of the British Constitution were extended to Canada. Two houses of legislature were at the same time appointed, namely, a legislative council and assembly. The legislative council of Upper Canada consists of not fewer than seven members; and that of Lower Canada of not fewer than fifteen, appointed by the King. The house of assembly is composed of fifty-two members, who are generally extensive proprietors of land. In the districts and counties, the possessors of a property of the annual value of forty shillings are qualified to vote; and in the city of Quebec and the other towns, the voters must either be possessed of a dwelling-house, and a piece of ground, of not less annual value than L. 5 Sterling; or they must have been settled for a year, and have paid one year's rent, not under L. 10. There exists no disqualification in this country for any office, or for the exercise of any political privilege, on account of religious tenets; and great practical benefit is found to result from this unreserved toleration, which has the effect of reconciling the different sectaries to each other, and of abating that mutual rancour necessarily arising from a system of exclusion. The executive government consists of a Governor, who is generally a military officer, and Commander of the forces, a Lieutenant-Governor, and an Executive Council, amounting to seventeen, appointed by the King, and exercising an influence in the affairs of the province, similar to that of the Privy Council in the affairs of England. The Governor has the power to prorogue and to dissolve the assembly. He is also invested with the prerogative of giving the royal assent or refusal to all acts which have been approved by the two houses of legislature.

roads and instances. The following table of the roads and distances in Canada may be found useful.

VOL. II. PART II.

Roads and Distances in Canada.

Canada.

From Quebec to Halifax.

	Miles.
From Quebec to Point Levi, across the river	1
Thence to the portage at Riviere du Cap	121 ¹ / ₂
Thence to Timiskuata	36
Thence to the settlement of Maduaska	45
Thence to the great falls in River St John	45
Thence to Fredericktown	180
Thence to St John's	90
Thence to Halifax	189 ¹ / ₂
	708

From Quebec to Michillimakinak, at the entrance of Lake Huron.

	Miles.
To Montreal	184
To Coteau du Lac	225
To Cornwall	266
To Matilda	301
To Augusta	335
To Kingston	385
To Niagara	535
To Fort Erie	560
To Detroit	790
To Michillimakinak	1107
	4698

From Quebec to New York, by way of Montreal.

	Miles.
To Cape Rouge	9
To St Augustin	9
To Jacques Cartier	15
To St Anne's	30
To Three Rivers	22
	85
To Riviere du Loup	27
To Berthier	22
To Repentigne	32
To Montreal	18
	99
To La Prairie	9
To St John's	14
To Isle au Noir	14
To Windmill Point	12
To Savage's Point	6
To Soudar	30
To Burlington, the first post town in the States	14
	89
To Skeneburgh	78
To Fort Anne	12
To Dumost Ferry	24
To Waterford	24
To Albany City	12
	150
To Hudson City	34
Carry forward,	184

Canada
|
Canary
Islands.

	Brought over,	184
To Rhinebeck	-	31
To Poughkeepsie	-	17
To Peckskill	-	84
To Kingsbridge	-	34
To New York	-	15
		— 165
		588

The expence of travelling post in Lower Canada is 1s. currency *per* league. The American packets on Lake Champlain, charge from three to four dollars for the passage from St John's to Skenesburgh, a distance of nearly 160 miles, and from Skenesburgh the traveller proceeds to New York, in a waggon or stage, at the rate of 3d. Sterling *per* mile.

See *A Topographical Description of the Province of Lower Canada, with Remarks upon Upper Canada*, by Jos. Bouchette, Esq. 1815.—Weld's *Travels through the States of North America in 1795, 1796, 1797*.—Heriot's *Travels through the Canadas, 1807*.—Grey's *Letters from Canada*.—Lambert's *Travels in North America, 1814*. (o.)

CANARY ISLANDS. In the *Encyclopædia* will be found some account of this Archipelago, so far as known at the time of its publication. Since that time, M. Bory de St Vincent has published his *Essay on the Fortunate Islands*, in which, besides giving the result of his own observations, he has collected, with great industry, all that is to be found in the Spanish writers on the subject. M. Humboldt also, who, in his way to South America, ascended the Peak of Teneriffe, has communicated, in his *Personal Narrative*, a number of learned and curious remarks. From these sources we have derived a considerable accession of new materials.

Original Inhabitants.

It is not proposed to follow M. Bory into his speculation concerning the ancient Atlantic Continent, of which the Canaries appear to him to have composed a fragment; because the whole theory appears to us destitute of any solid foundation. He has collected, however, from the early Spanish historians, a variety of particulars respecting that singular people, called the Guanches, by whom the Canaries were originally inhabited. They appear to have considerably surpassed in civilization, both the inhabitants of the West India Islands, and those of the opposite Continent of Africa. The most remarkable of their customs, and of which monuments still remain, was that of embalming the bodies of their dead. This operation was performed by extracting the intestines, washing the whole body with salt water, and filling the large cavities with aromatic plants. The bodies were then dried in the heat of the sun, or, if that were wanting, in a stove. Where this method was too expensive, corrosive liquids, calculated to destroy the intestines, were merely poured down the throat previous to desiccation. The embalment being completed, usually in about fifteen days, the body was sewed up in several folds of goat skin, was placed in a chest or coffin, cut out

from a single piece of wood, and was finally lodged in a grotto excavated from the rock, and the entrance of which was carefully guarded. These mummies or *sasos*, as they are called, when found at the present day, are of a tanned colour, and usually of an agreeable odour. They are often perfectly well preserved, particularly the hair; the features are distinct, but drawn back; the belly sunk. On being taken out of the goat skins, and exposed to the air, they fall gradually into dust.

The Spanish authors have translated some specimens of the poetry of the Guanches, which display considerable imagination and sensibility. The females appear to have been treated with a respect very unusual among savage tribes. In the island of Lancerota, a plurality of husbands is said to have prevailed, as in Thibet. There were a species of vestal priestesses called *Malgades*, who were held in the utmost veneration, and supposed to enjoy peculiar communication with the divinity. The form of government was highly aristocratic. A tradition prevailed, that the nobles were created first, and had the property of the earth, and of all its productions vested in them; after which a supplementary creation took place of beings destined solely to perform the office of slaves. They had a king, however, but of limited power. There are reports of the existence, among the Guanches, of a race of giants; and the Spanish annals mention one chief who was nine, and another who was fourteen feet in height; but these are evidently fables, such as are found in the early traditions of every nation.

The Guanches have long been entirely extinct. They made a vigorous resistance to the invaders; but the sword of the Spaniards, aided by a pestilential disorder, soon swept entirely this ancient population from the face of these islands.

The information furnished by Humboldt relates chiefly to the physical aspect and present state of the Canaries. In ascending the Peak of Teneriffe, he found five zones of vegetation. The first was that of vines, rising about two or three hundred toises above the sea. It forms the only part of the island which is much inhabited, or carefully cultivated. Here corn, the vine, the olive, the fruit trees of Europe, the date, the plantain, the Indian fig, the *arum colocasia*, are found in a flourishing state. The bread-fruit, cinnamon, coffee, and cocoa, have been tried with success. The second zone, or that of the laurels, contains the wooded part of Teneriffe. It contains four species of laurel, an oak resembling the *quercus Turneri* of Thibet, a native olive, the largest tree of this zone, and several species of myrtle. The third zone, beginning at the height of 900 toises, and extending 400 upwards, consists entirely of a vast pine forest. The tree resembled the Scotch fir; but M. Humboldt, not having an opportunity of examining the fructification, could not determine whether there was any thing peculiar in the species. The fourth and fifth zones, called those of the Retama and the Gramina, consist of an immense plain, or rather sea, of sand, covered with pumice stones and large blocks of obsidian. In its lower part, are scattered tufts of the retama (*spartium nubigenum* of Aiton), a beauti-

ful plant, whose odoriferous flowers render delicious the flesh of the goats who feed upon them. At the upper end of the plain, grasses and lichens faintly struggle against the volcanic matter. At 1530 toises above the sea, they reached a station comanonly called the *English Halt*, consisting of a cavern inclosed between two rocks. Here they spent the night, suffering considerably from cold. Next morning, after two hours walk, they came to a small plain called *Alta Vista*, where persons called *Neueros* were collecting snow for the use of the inhabitants of the coast. Then began the *Malpays*, a tract entirely destitute of mould, covered with fragments of lava, which, sinking beneath the feet, rendered the ascent very laborious. The guides now earnestly dissuaded them from proceeding farther, and were found, on examination, never to have themselves reached the summit. At the extremity of the *Malpays*, however, the travellers came to a small plain, whence they saw rising the cone of the *piton*. This hillock is extremely steep, and is so covered with volcanic ashes and fragments of pumice stone, as to render the ascent scarcely possible. They succeeded only by following a current of old lava, the wrecks of which formed a wall of scorious rocks, by grasping the points of which, in half an hour, they reached the top. This volcano appeared to Humboldt the most difficult to ascend of any he had seen, except that of Jorullo in Mexico.

On arriving at the summit, our traveller was surprised to find scarcely room to sit down. The crater was inclosed with a small circular wall of porphyritic lava, with basis of pitchstone. This wall, at a little distance, has the appearance of a small cylinder or a truncated cone. It would have entirely blocked up the approach to the crater, had there not been a breach on the east side, through which they descended into the funnel. They found it of an elliptic form, 300 feet in length, and 200 in breadth. It is remarkable, that these dimensions are only a fifth part of those of the crater of Vesuvius. In fact, very lofty volcanoes usually throw out the matter by lateral openings, so that some of the greatest among the Andes have very small apertures at the summit. The inside of the funnel indicated the appearance of a crater which had not thrown out fire for thousands of years. There were none of those layers of scoriae and ashes, which mark recent volcanic action; the floor was strewed with fragments of stony lavas, which the action of time had detached from the sides. The strata along the edges were very irregularly piled over each other, exhibiting various grotesque ramifications. The inclosing wall is snow white at its surface, owing to the action of sulphuric acid gas on pitchstone porphyry. The aspect of the whole is rather curious than awful. "The majesty of the site consists in its elevation above the level of the ocean, in the profound solitude of those lofty regions, and the immense space over which the eye ranges."

The view from this point is described by Humboldt as interesting in a very peculiar manner. He observes, "Travellers have learnt by experience, that views from the summit of very lofty mountains

are neither so beautiful, picturesque, or varied, as those from the summit of heights which do not exceed that of Vesuvius, Rigi, or Puy-de-Dome. Colossal mountains, such as Chimborazo, Antisana, or Mount Rosa, compose so large a mass, that the plains, covered with rich vegetation, are seen only in the immensity of distance, where a blue and vapoury tint is uniformly spread over the landscape. The Peak of Teneriffe, from its slender form and local position, unites the advantages of less lofty summits to those which arise from very great heights. We not only discover from its top a vast expanse of sea, but we see also the forests of Teneriffe, and the inhabited part of the coasts, in a proximity fitted to produce the most beautiful contrasts of form and colouring. The volcano seems as if it crushed, with its mass, the little isle which serves for its basis, and shoots up from the bosom of the waters to a height three times loftier than the region where the clouds float in the summer." The remarkable transparency of the atmosphere increases greatly the apparent proximity in which the hamlets, vineyards, and gardens on the coast are beheld.

The Peak appeared to Humboldt to be composed entirely of volcanic products, without any mixture of primitive rocks. It is peculiarly distinguished by the vast quantity of obsidian, a substance not found in the immediate vicinity of almost any other volcano. It alternates with, and passes into pumice, in a manner which convinced our traveller that pumice was merely tumefied obsidian. These two rocks, together with a porphyry consisting of vitreous lava in a basis of pitchstone, composed the whole upper part of the Peak. Although the crater was entirely silent, yet, near the summit, vapour, which condensed into pure water, issued from different spiracles, called the *Nostrils of the Peak*.

The active volcanos of Teneriffe are considered by Humboldt to be merely lateral eruptions of the great volcano. The only one recently in operation, is the volcano of Cahorra, situated on the west side of the Peak. After a long silence, it began its discharge on the night of the 8th of June 1798. A hollow and stifled sound was first heard, like that of distant thunder; then a louder noise, like that of matter in violent ebullition; after which another sound, which resembled a great discharge of artillery. A short interval still elapsed, till the liquified substances began to ascend. Four mouths were opened, of which the two highest threw up only red-hot stones. The third poured out lava, but slowly; and it is fortunately surrounded by a rampart of rocks, the interval between which and the volcano must be filled up, before the stream could reach the cultivated fields.

Humboldt observed the other islands merely by sailing along their coasts. Lancerota exhibited every mark of having been recently overwhelmed by volcanic agency. This appears to have taken place in 1780, when nine villages were entirely destroyed. The summit of its great volcano did not appear to exceed 300 toises. The coast of Graciosa is distinguished by rocks of basalt 500 or 600 feet high, which frown in perpendicular walls over the ocean,

Canary Islands.

like the ruins of vast edifices. One of them so exactly resembled a castle, that the French captain saluted it, and sent a boat on shore to make some inquiries of the governor.

All the rocks which Humboldt observed, were thus either volcanic, or of very recent trap formation. M. Broussonnet, however, who spent a long time upon these islands, stated, that Gomera was composed of the primitive rocks of granite and mica slate. The Grand Canary has never been explored; but it struck Humboldt as wearing a different aspect from the rest, its mountains being disposed in parallel chains.

Present state of Teneriffe and the other Islands.

The eastern side of the Island of Teneriffe is entirely naked and barren; but the northern and western sides are beautiful and fertile. It does not produce two-thirds of the corn necessary for its own consumption, but is supplied from the other islands. Santa Cruz, the capital, is situated on the eastern side; the convenience of the harbour and situation compensating for the barrenness of the surrounding country. It supports itself by trade, forming, as it were, a great caravansary between Spain and the Indies. English ships often touch at this port for fresh provisions, which are obtained of excellent quality, though chiefly from the neighbouring island of Canary. The appearance of this city, which exhibits houses of dazzling whiteness, with flat roofs, and windows without glass, stuck against a perpendicular wall of basaltic rocks, appeared very unpleasing to Humboldt. The streets, however, are neat, with foot-walks on each side. The houses within are remarkably spacious; the halls and galleries so extensive as, in M. Bory's opinion, to exclude the comfortable feeling of a house, and rather to suggest that of an open space. The road is excellent, and forms the chief recommendation of Santa Cruz. The harbour is well built, but the landing difficult and even dangerous. The population is estimated at 8000 souls.

Laguna is the nominal capital of Teneriffe, and contains the tribunals belonging to the island; but since the volcano of 1706 destroyed its port of Garachico, then the finest on the island, its commerce has been supplanted by that of Santa Cruz, and it has been in a state of rapid decline. It still, however, contains 9000 inhabitants. The situation is beautiful, about 350 toises higher than Santa Cruz, and crowned by a wood of laurel, myrtle, and arbutus, which maintains a delightful coolness. The situation of Orotova is still finer, and it is refreshed by numerous rivulets passing even through the streets. Its aspect, however, is gloomy and deserted, and it is chiefly inhabited by a haughty race of nobility. The population amounts to 7000, with 8000 in its port of Santa Cruz. The road is bad.

The other islands have been very little examined. The Grand Canary is said to surpass Teneriffe in fertility, but has been much neglected. Its chief town, Guidede las Palmas, contains upwards of 9000 inhabitants, and is the ecclesiastical capital of the islands. Lancerota and Fortaventura are the most arid, and their soil so nearly resembles that of the African continent, that the camel has been introduced with success.

The following statement is given by Humboldt of the progressive population of the different islands.

	Surface in Nautical Leagues.	POPULATION in			
		1678.	1745.	1768.	1790.
Teneriffe . .	73	49,112	60,218	66,354	70,000
Grand Canary	60	20,458	33,864	41,082	50,000
Palma . . .	27	13,892	17,580	19,195	22,600
Lancerota .	26		7,210	9,705	10,000
Fortaventura	68		7,382	8,863	9,000
Gomera . .	14	4373	6,251	6,645	7,400
Terro . . .	7	3297	3,687	4,022	5,000
Total	270		136,192	155,866	174,000

The inhabitants are said to be of an active and industrious disposition. They have emigrated in great numbers to the different parts of South America, where they are supposed to be as numerous as in their native islands. They are fond of considering these as a portion of European Spain, to whose literature they have made some not unimportant additions, by the labours of Clavijo, Vieyra, Yriarte, and Betancourt. A most formidable list of prohibited books is exhibited at Laguna, but this only whets their avidity after these forbidden treasures.

The chief article of export is wine; of which the average produce in Teneriffe is estimated by M. Bory at 22,000 pipes. Lord Macartney reckons 25,000, and Mr Anderson (in *Cook's Third Voyage*) 40,000; but this last amount is doubtless greatly exaggerated. A large proportion is consumed in the island; the export, chiefly to Britain and America, amounts to 8000 or 9000 pipes. The other exports are brandy, raw silk, soda, and some fruits, which, however, are not equal in quality to those of Portugal. The revenue amounts to 242,000 piastres. (2.)

CANNON, THE ART OF CASTING. Formerly the mould for casting cannon was of loam, and now is usually made of dry sand. Loam for making Moulds, is an earth consisting principally of clay. It is passed through sieves and then mixed, whilst wet, with horse dung, cow's hair, chopped straw, or tow cut short; the loam being mixed up with one of these substances, they are well beat up together on a wooden board with an iron bar; by this addition, the loam becomes susceptible of being dried rapidly without cracking. The most attenuated loam is used for the surface of the mould that is to come in contact with the metal, to the end that the surface may come off smooth. The loam-moulders are a particular class of workmen different from the common sand-moulders. The business to which they are bred, consists in making of loam and of dry sand, the moulds for steam-engine cylinders, pipes for conveying water, boilers, guns and other large articles.

Formerly on a tapering wooden spindle, entwined with straw ropes, a model was made of loam, copied

Cannon.
 Old Method
 of forming
 the Loam-
 Moulds.

exactly from the pattern gun; this model was painted over with a coat of wood ashes mixed with water. By means of this coat, no adhesion took place between the convex model and the loam which was afterwards applied; over this coat of ashes, successive coats of loam were applied, each being dried by fire before the next was laid on; the whole was bound externally with longitudinal iron bars, and with hoops transversely. Over this carcass of iron, a coat of plaster of Paris was applied. This was dried, and then the spindle and its envelope of straw was taken out. The interior convex model being thus deprived of its core and support, fell to pieces and was picked out; and then a hollow mould of the gun remained. In this way the mould for the body of the piece was formed; the moulds for the breech and head were made separately; these three parts were joined together so as to form a complete mould. This method of moulding guns required the construction of a new convex model for every gun that was moulded; It was used in the French Government founderies of Douai, Ruelle, near Paris, and Strasburg, in 1794.

Another
 Method.

The following method of constructing the loam-mould, is an improvement on that just mentioned: A model of wood, or to prevent change of form by moisture, a model of brass or pewter is made and formed on the turning lathe, with its exterior surface exactly resembling that of the gun, with its head and the square piece at the cascabel; if the model is of metal, it is made hollow for the sake of lightness. This model is laid with its longitudinal axis horizontal, and one half immersed in a bed of sand; upon that part of the model which projects above the sand, successive coats of loam are applied and pressed on the model. When the first layer is dried by fire, a second layer is applied and dried, and so on till the model is covered with a coat of loam four or five inches thick. Over this an iron carcass is applied, and over the carcass another coat of loam. The mould with the model in it is now turned, so that the half already covered with loam shall be lowermost. The plain surface of the loam which had been in contact with the sand, is painted over with a coat of blacking, composed of finely powdered charcoal mixed with clayed water; this prevents the adhesion of the flat surface with the loam that is to be laid on it. A layer of loam is applied upon the naked half of the model. This is dried, and several more layers are applied successively. A carcass is put over the loam corresponding to the carcass of the first half, so that these two carcasses can be bound together with bolts and wedge-formed keys, with screw-bolts and nuts, or tied with iron-wire. When the loam is dry, the upper half of the mould is lifted off, the model is taken out, and the interior surfaces of both parts of the mould are painted over with blacking; this prevents the loam from being melted, and from adhering to the hot metal. The two halves of the mould are then put together, and the carcasses are firmly connected by their bolts; the whole is thoroughly dried by fire. When dried, the mould is placed vertically in the pit of the casting house, with the

breech lowermost, sand is beat round it for support, and the metal is poured in at the top of the head. This method was practised in the Arsenal of Paris in 1794.

Cannon.

The most approved method of constructing the Dry Sand Moulding. mould of a gun is in dry sand, and this is the method now practised in Britain. Guns cast in loam do not come from the mould with a surface so correctly resembling that of the model as those cast in dry sand, and in order to render the surface correct, and to remedy defects, it was always necessary to subject them to the process of turning. In guns carefully cast in dry sand, the process of turning might be dispensed with, the gun would then be strengthened by the outer skin of metal which, having cooled more rapidly than the other parts, is the hardest; this outer skin is also less liable to rust than the surface laid bare by turning. The mould of a gun in dry sand, at the same time that it is more accurate, is also sooner made and dried than a loam-mould. Dry sand-moulding is a part of the business of the loam-moulder.

The sand for dry sand-mouldings is made by mixing a quantity of sharp refractory sand with water in which clay has been diluted. After the mixture is thoroughly made, if a handful is grasped, and on opening the hand the sand retains the form given it, then the consistence of the mixture is good. The sand should have the following qualities: 1st, It should not be fusible by the heat of melted cast-iron; if it were, it would adhere to the metal, and make the surface of the gun rough. 2^{dly}, It must be sharp, and composed of angular particles; if the particles of the sand were round, it would not hold together on taking out the model. 3^{dly}, It must not contain too much clay, for in that case it would crack in drying. 4^{thly}, It must contain a certain proportion of clay to retain the form that the model impresses on it.

For dry sand-moulding, a pattern of wood may be used, turned exactly to the form of the gun; or to avoid expansion from humidity, the model or pattern, as it is termed in the founderies, may be of metal. Brass or pewter are preferable to iron for making patterns, as a smooth surface may be more easily given them, so that they may leave a correct impression and may come out well from the sand. The metallic pattern is hollow, that it may be lighter and more easily handled; it is in different pieces; each piece fits into the adjacent piece by a rabbet.

The length of each piece of the model should be a very little greater than the given length of the corresponding part of the gun; because the length of the mould is the length of the gun whilst hot; and this is longer than the length of the gun when it comes to the temperature of the atmosphere, at which temperature the dimensions of the guns are given. It has been estimated that some kinds of cast-iron contract six-hundredths of an inch in a foot, in passing from the liquid state to the temperature of the atmosphere. This contraction is not considerable enough to be taken into consideration in the diameter of the pattern. The shrinking of the sand in drying, though not considerable, tends like-

Cannon. wise to make the piece shorter, and is another motive for making the pattern a little longer than the dimensions taken from a gun at the usual temperature. The patterns of the trunions are attached to the pattern of the second reinforce by screws, so as to be unscrewed and separated when the pattern is to be lifted out of the sand.

Gun-Boxes. The gun-box, in which the dry sand mould is to be formed, is of cast-iron, and cast in sand. It consists of several portions; each of these portions has flanges by which it is fixed to the others, and the whole, when connected together, form the gun-box. In the flanges are holes through which bolts are passed; the bolts are secured by wedge-formed keys; thus the different parts of the box are firmly held together. The two portions of the gun-box which contain the breech-ring and cascabel are single, not being divided longitudinally. Each of the other five transverse portions is divided longitudinally into two. A handle is fixed to each portion of the box, for the purpose of moving it. The upper transverse portion AA contains the gun-head. In each of the two portions BB, which contain the second reinforce, there is a lateral projection for the trunions. The figure represents the gun-box with the breech lowermost, in the position in which it is placed when the metal is poured in.

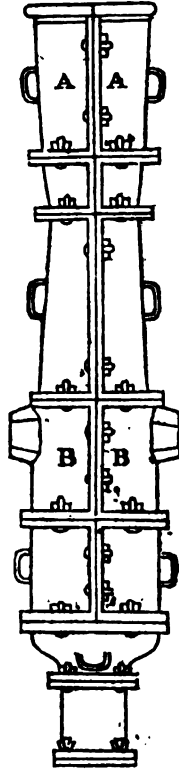

Forming the mould.

To make the mould, the pattern of the breech is first placed on a board, and the corresponding portion of the gun-box is put over it, and sand is rammed between the pattern and the box. The flat exposed surface of the sand is painted over with blacking, which consists of charcoal and clayed water, that there may be no adhesion with the sand of the next portion of the mould. The pattern of the first reinforce is now fitted into the pattern of the breech, and the corresponding portions of the first reinforce box adjusted on the flange of the breech box. Sand is well rammed, in small quantities at a time, between the pattern and the box; and the upper flat surface of the sand is painted over with blacking. The mould is completed by adding the remaining pieces of the model and of the box, one above another, ramming the sand, and painting the transverse surface of the sand at the top of each division of the box with blacking. The sand must be strongly rammed and equably, that every part of its surface may be able to resist the pressure of the liquid metal. Three little wedges are interposed between the two adjacent transverse portions of the box, that the sand may project a little, so that after it is dry it

may be flush with the box; if this were not done, there would be an interval between the adjacent surfaces of the sand, through which the metal would pass and form a fin.

When every part is moulded, the box is taken to pieces, and the parts of the pattern are carefully taken out of the sand, for which purpose they are first struck with a wooden mallet. Each part of the mould is then carried separately to the stove to dry. The stove is a room 12 or 15 feet square, with large iron doors on one side; the fire is made in a large conical grate placed on the middle of the floor; the smoke issues by an aperture in the brick ceiling. The heat in this stove is considerable, but it must not be so great as to make the boxes red-hot, for then, by the expansion of the iron, the mould would be injured; the moulds take about 15 hours to dry in this situation. When the moulds are taken out of the stove, their interior surface is painted over with a coat of blacking, that there may be no adhesion between the mould and the metal.

The pieces of the gun-box containing the mould are then taken to the pit, and being carefully placed the one upon the other by the crane, they are put together and secured by their bolts. The mould is placed with the breech undermost; the axis of the mould is made perpendicular to the horizon by a plumb-line, that the weight of the melted metal may press equably, and not more on one side of the mould than on another. It is not necessary that sand should be rammed round the mould, the box being strong, and its parts firmly bound together, so as to require no additional support. The mould is now in a position for the metal to flow into it through its open end, which is the extremity of the head. Whether the gun is to be of cast-iron or brass, the construction of the mould is the same.

The pig iron from which the gun is to be made is melted in a furnace, called an air-furnace in the iron-founderies, and termed by some authors a reverberatory furnace. The flame of pit coal is carried by a current of air, so as to play upon the pig iron. The stack of the chimney is 40 feet high. By the pressure of the unrarified external air on the lower part of the rarified column of air in the furnace and chimney, the current of air through the furnace is produced. The grate G is larger than any other transverse section of the furnace. (See figure next page.) The furnace has three openings, one C, for introducing the coals; the second P, which has a sliding brick door, with a counterpoise, serves for introducing the pig iron. The third I is for the purpose of stirring the metal, and taking out the melted iron for small castings by iron ladles coated with clay, and made red-hot. This third opening has a door of fire brick, the joints between the door and the door-frame are luted. In the middle of the door is a hole, through which the state of the melted metal may be seen. There is likewise a smaller opening T for letting out the melted metal.

The furnace and stack are of brick. The interior of the furnace is a coating of fire brick, 9 inches thick, detached and separate from the outer coat, and the other parts of the building, in order that the

Cannon. heat may not melt the common brick of which the outer parts are composed. The fire-brick is made of refractory clay, which, containing little iron, and little or no calcareous matter, burns white, and sustains a great heat without melting. These bricks are made of Stourbridge clay, or of a light blueish grey stratified clay found in the strata that accompany coal. The clay is first ground, the pieces of ironstone picked out, and then made into bricks. In making the interior coating of the furnace, the bricks must be built with moistened fire-clay, and not with lime mortar. The quantity of metal put into the furnace should be equal to the weight of the solid unbored gun with its head, and something more in case of need. It requires a large air-furnace to contain metal enough for one large gun.

Quality of the Iron. The pig-iron for guns should be grey, that kind having most tenacity; white pig-iron is too brittle, and so hard that the head cannot be cut off, nor the gun bored.

Charging the Furnace. A bed of sand N is made in the furnace on which the pig-iron is to be laid. The furnace is heated to a white heat, till the sand is vitrified, which is known to have taken place by touching the surface of the sand with an iron ringard. The brick door is then lifted up, and the pig-iron is laid on the bed of sand. The heat should be applied so as to produce a speedy fusion, for if the iron is long exposed to heat before melting, a portion of its carbonaceous matter is burnt, and it passes from the state of grey cast-iron to that of white. In situations where pit-coal cannot be had, wood may be used in the air-furnace, but the heat given by wood is not so great as that produced by pit-coal. To obtain the most heat that the wood is capable of affording, it should be well dried, cut into small logs, and the logs should be placed with their end upon the grate.

The pig-iron melted by the flame playing on it, flows down into a cavity L, which has a hole T opening outwardly, and stopped with clay. When the hole is forced open by a workman, the metal issues and is conveyed by a gutter formed of sand to the gun-mould, into which the melted metal falls through the open end of the head. The sand forming the gutter should be in a proper state of moisture. If it is too dry, some pieces of it will be carried away by the metal. Across the gutter is a dam composed of an iron-plate luted, and dipping a little below the surface of the metal to retain the scoriae. This dam is driven down to stop the current of metal when the mould is full. The metal is also skimmed, as it passes along, by a skimmer, composed of a rod of iron terminated by a flat semi-elliptical piece luted and made red hot. It is sometimes the practice to plunge a piece of green wood for a short time into the head whilst liquid. This is with a view to prevent honeycombs, and its action may be to metallize any oxidated particles of the metal; and that the vapour from the green wood rising to the surface of the metal may carry with it small air bubbles, or other extraneous bodies that would, if they remained, occasion cavities in the metal.

Explanation of the Figure. The figure is a transverse section of the air-furnace. C is the opening through which the coals are introduced. P the opening at which the pig-iron is

thrown in. T the hole through which the metal is let out. The metal flows into the casting-house. O the floor of the casting house. In this floor is the pit in which the moulds of large goods are sunk, that the metal may flow down into them. I the door, with a hole in it, for seeing the state of the melted metal.

Cannon.

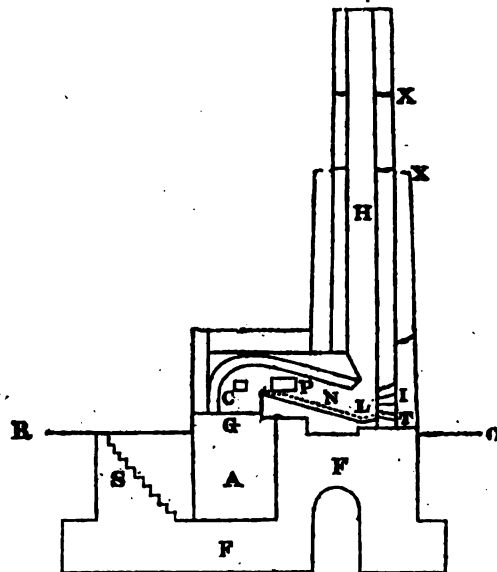

G the grate. L the lower part of the cavity of the furnace, into which the metal, as it is melted, flows. S steps leading to A, the ash-pit. N bottom of the furnace lined with sand. H chimney; the height of the stack is 40 feet from the surface of the ground. The stack is strengthened in different places by iron bars, X. F is the mass of building which forms the foundation built below the surface of the ground to support the weight of the furnace and stack. R the surface of the ground out of doors. C P N L H is the course that the flame takes.

It is better to cast the guns from the air-furnace than from the blast-furnace; for in the blast-furnace, where the ironstone is smelted, the quality of the metal is uncertain, and it may vary from one cast to another, by causes either unknown, or not under the control of the iron-master. On the other hand, in the air-furnace, pig-iron of a quality proper for making guns is put in, and the quality of the iron is not materially altered by the process of melting.

The head of the gun is like the jet (gate or geet of the workmen) of any other casting. Whilst the whole is liquid, the head is a column of liquid metal that acts by its height, exerting pressure on the metal that forms the body of the gun. The metal subjected to this pressure whilst liquid, is less subject to porosity when cooled. The head also furnishes metal to fill up the cavities that occur in the piece by the contraction and crystallization of the metal whilst it is passing to the solid state. All the great contractions and crystallizations are thus transferred to the surface of the head, which is found, to be composed of large cavities, sometimes containing cast-iron crystallized in a fern-leafed shape. The head

Cannon.

also serves to receive any impurities that may have escaped the attention of those appointed to skim the iron as it flows along the gutter.

In ten or twelve hours, the piece is sufficiently cool to be removed. It is then stripped of the mould, and taken to the boring-mill, to undergo the operations described under our article BORING OF CANNON. Mortars, howitzers, and carronades are moulded, cast, and bored in the same way as long guns.

The English Board of Ordnance is supplied with iron guns by contract. The contractors are those iron-masters who offer the guns at the lowest price, and the guns are cast at their works in the country. The guns are sent to Woolwich to be examined in respect to their dimensions, the coincidence of the axis of the bore with that of the piece, the position of the touch-hole, and to undergo a proof by powder. It is also tried whether water can be forced through the substance of the gun. If any cavities called honey-combs be found in the bore, the piece is rejected. The proofs are at the risk of the contractors, who generally examine and prove the guns at their works, before sending them to Woolwich. Unserviceable guns are taken to the triangle, where a large mass of cast-iron is let fall upon the gun, from a height of 40 or 50 feet. It is thus broken into pieces of a size fit for being introduced into the air-furnace to be re-cast. Some brass guns are cast and bored in the foundery of the Board of Ordnance at Woolwich.

Brass Guns.

Cast-iron guns have the advantage of not suffering any injurious alteration from the heat of repeated firing. Brass guns, when fired rapidly in succession, droop at the muzzle. Cast-iron guns alone are used on board British ships; brass guns are now principally used for field-pieces. Brass guns, in strict and precise language, might be called bronze guns, as the word brass is most commonly used to denote a composition of copper and zinc, whereas, in gun-metal, there is generally little zinc, and often none. Copper alone is too soft, so that the guns that have been made of it were cut and furrowed by the ball in firing. Use is made, therefore, of a mixture of copper and tin; this composition being harder than copper. Copper and tin separately are soft and malleable; when combined they form a composition that is hard and brittle; and these two qualities are increased by augmenting the relative quantity of tin. Different proportions have been employed for guns; 10 parts by weight of copper, and 1 of tin, is a proportion that is found to give the requisite hardness, and not too much, nor too great brittleness. The copper is first melted, and the tin is added. If the tin were melted first, and the copper added, much of the tin would be oxidated before the combination took place; the metal, during the process, is stirred with a rod of green wood.

Bell-metal is a combination of copper and tin in other proportions. It is made hard by means of tin, in order that it may be sonorous. It contains 25 per cent. of tin, and is too brittle and too hard for making guns. In the year 1794 the Revolutionary Government of France obtained gun-metal by depriving bell-metal of a part of its tin. Bell-metal was heated with the contact of air, and stirred to oxidate the

tin; the bell-metal was thus reduced to the state of Cannon. a coarse powder; this powder was thrown into another quantity of bell-metal in fusion; the metallic and oxidated copper in the powder melted, and was mixed with the already fused bell-metal; the oxide of tin of the powder remained on the surface. A melted mass was thus obtained, containing a larger proportion of copper than the bell-metal, and fit for making guns.

The mould for brass guns is formed of dry sand, in the same way as the mould for cast-iron guns already described. The furnace for melting brass for guns is a reverberatory furnace, the metal being exposed to the flame. It has no high chimney like the air furnace for melting iron, the heat required not being so great as that for melting cast-iron.

Brass guns are subject to melt at the interior extremity of the touch-hole, by the heat of quick firing; and the melted parts are driven out by the explosion, so as to render the touch-hole too wide. To prevent this, there is sometimes a bush of copper inserted, and in this bush the touch-hole is drilled. The copper being less fusible than the brass, is not melted by the heat of firing the piece. To form the bush, a cylindrical piece of copper is hammered cold, and made into the form of a male screw. A hole is then bored, reaching from the surface of the gun into its bore; the diameter of this cylindrical hole is equal to the diameter of the cylinder of copper measured from the bottom of the threads of the screw. The piece of copper is then screwed into the cylindrical hole, and the touch-hole is drilled in it.

The improvements in casting cannon, as in other ^{parts} arts, have been gradual. Formerly cannon were cast with a core, and this was practised in some founderies in Flanders, even in the year 1794. But they are now always cast solid, experience having shown that guns cast solid are stronger, and less liable to burst, and the bore is freer from honeycombs, and more likely to have the same axis with the piece. The second of these qualities is still more certainly attained by the practice now in use, of making the gun itself revolve whilst boring; in this way, as long as the boring bar remains unmoved, the axis is right; but if the boring bar has a conical motion, then the point of the bit is out of the axis; when the boring bar was made to revolve, the bore might deviate greatly from the axis. The improvements in the casting of cannon have kept pace with the improvements in the manufacture of cast-iron.

The art of casting iron was known to the ancients, as appears from a small antique statue of Hercules, of cast-iron, dug up at Rome. In China it appears to be practised with a dexterity visible in the Chinese specimens of many other arts. In modern Europe it has grown with the general advancement of society, and has latterly attained to a high degree of improvement in this Island, where individuals having the command of capital, and the power of making advances for the salaries of workmen and the construction of buildings, were induced to form large establishments for the smelting of ironstone, and for the manufacture of cast-iron. In

Cannon. France cast-iron is little used; many of the articles which in England are of cast-iron, being there of wrought-iron, copper, earthenware, or wood. In the Prussian dominions, the art of casting statues and small medals, in cast-iron, is successfully practised. But in none of the other countries of Europe is cast-iron so generally used, and nowhere is it manufactured on so large a scale, and with the employment of so much capital, as in Britain.

extended of the Use of Pit-coal. Pit-coal has been the main instrument in this extensive manufacture. As it gives a better heat for the melting of cast-iron, and saves the great extent of ground required for rearing wood, the greatest part of the cast-iron in Britain is now extracted from the ironstone, and made into castings by pit-coal. Pit-coal began to be used in smelting of ironstone in 1619. This first operation was performed in Worcestershire, by Dudley, who describes his process in a book, entitled, *Metallum Martis*. The manufacture of cast-iron was not much advanced one hundred years after; for in the first half of the eighteenth century, cast-iron goods were imported into some part of Britain from Holland. And the Dutch chimney-backs, with the figure of a parrot, are to be seen in old country houses in Scotland to this day.

Two kinds of mineral are smelted for iron in Britain. The first is the hæmatites of Ulverstone and the neighbourhood of Whitehaven, which, as it contains much iron (60 per cent.), is carried by sea to smelting furnaces in different parts of Britain. The second is the argillaceous ironstone, which constitutes some of the strata that accompany pit-coal. This is more generally used than the hæmatites. And it is in the vicinity of the masses of stratified minerals, which yield coal and ironstone, that the principal iron-works in Britain are set down. These strata are found in various parts of the island, and are portions of that class of depositions called by geologists the coal-formation. A stratum of coal or of ironstone of considerable extent, is termed, by the coal and iron masters, a coal-field, or an ironstone field.

Pit-coal cannot be employed entire in the blast-furnace; the bituminous part would be conglutinated by the heat, and the furnace would be choked, and the materials would no longer descend gradually as they ought to do. The coal is, therefore, burnt to

drive off its bitumen, and it is then in a state of cinder and called coak. It requires a larger mass of coak than of charcoal to smelt ironstone. Hence the coak blast-furnaces are large, and the machines employed to blow them are more powerful than the wooden spring bellows invented in Germany, in 1620, and which continue to be employed in the charcoal iron furnaces in Germany and France. Bellows connected by leather, and worked by water, were used to blow the blast-furnaces at Carron, at the commencement of that establishment in 1760. Sometime after, these bellows gave place to blowing machines, composed of pistons working in iron cylinders, constructed by the celebrated Smeaton, and described in his Reports. The blowing machines of the blast-furnaces in Britain are now always composed of pistons moving in iron cylinders. The improvements in the steam-engine have rendered practicable the working of blast-furnaces in situations where there is no fall of water; and, on the other hand, the manufacture of the various parts of numerous steam-engines, has called forth the abilities and ingenuity of the iron founder.

In consequence of the advanced state of the English cast-iron manufacture, several foreign nations have been desirous of introducing the English method, and have procured English workmen for that purpose. In this way, iron-works, on the English plan, were erected in Russia, about 1780, in Silesia in 1790, and in France, at Creusot, near Montcenis, there were three English coak blast-furnaces, begun about 1790.

The strength of guns depends on the strength of the metal of which the gun is composed, and on the quantity of metal and the manner in which it is disposed. This subject is considered in the article **Calibre, and Dimensions of Cannon.** *GUNNERY* of the *Encyclopædia*. The nature of the subject does not admit of determining with precision the best weight and length that can be given to a gun fitted for exploding a ball of a given weight. Guns of the same calibre are consequently made of different dimensions, even in the same country. The four tables that follow contain the weight, length, and other dimensions of British and of French guns:

I.—TABLE of the Length, Weight, Calibre, and Charges of British Government Iron Guns.

	Length.		Weight.		Diameter of the Bore.	Diameter of the Shot.	Diameter of the Shot Gauge.	Charge.		
	F.	In.	Cwt.	lb.	oz.	In.	In.	In.	Proof. lb.	Service. lb.
42 Pounder gun	10	0	67	0	0	7.018	6.684	6.795	25.0	14.0
32 Pounder gun	10	0	58	0	0	6.410	6.105	6.207	21.8	10.11
24 Pounder gun	10	0	52	0	0	5.824	5.547	5.639	18.0	8.0
18 Pounder gun	9	6	42	0	0	5.292	5.040	5.124	15.0	6.0
12 Pounder gun	9	6	34	0	0	4.623	4.403	4.476	12.0	4.0
9 Pounder gun	9	6	30	1	0	4.20	4.000	4.066	9.0	3.0
6 Pounder gun	9	0	24	0	0	3.668	3.498	3.552	6.0	2.0
4 Pounder gun	6	0	12	1	0	3.204	3.053	3.104	4.0	1.5
3 Pounder gun	4	6	7	1	0	2.913	2.775	2.820	3.0	1.0
2 Pounder gun	3	9	4	2	0	2.544	2.423	2.463	2.0	0.11
1 Pounder gun	3	0	2	2	0	2.019	1.293	1.955	1.0	0.6
½ Pounder gun	3	0	1	2	0	1.602	1.526	1.551	0.8	0.3

Canon. II.—TABLE of the Length, Weight, and Calibre of Iron Ordnance used on Board British Merchant Ships in 1811.

	Length from Base-ring to Muzzle end.	Weight.	Diameter of Bore.
	Feet.	Cwt. lb. oz.	Inches.
9 Pounder gun	5	14 2 0	4.2
6 Pounder gun	4 6	9 1 17	3.668
4 Pounder gun	4 0	6 3 21	3.204
12 Pounder car-ronade	4 0	10 1 0	4.52
9 Pounder car-ronade	4 0	8 1 23	4.11
9 Pounder car-ronade light	1 3½	6 2 21	4.11
6 Pounder car-ronade	3 6	6 0 8	3.6

III.—TABLE of the Length and Weight of Iron Guns used in the French Navy in 1794.

	Length from the extremity of the Pom-mel to extre-mity of Muzzle.	Length of the Head with which the Gun is cast.	Weight of the Gun.
	Pied. Pouce.	Pied. Pouce.	Lbs.
36 Pounder gun	10.	3. 0	7190
24 Pounder gun	9. 5½	3. 0	5116
18 Pounder gun	8. 10½	2. 6	4212
12 Pounder gun	8. 2½	2. 6	2995
8 Pounder gun long - -	6. 7½	2. 0	2382
8 Pounder gun short - -	7. 5½	2. 0	2056
6 Pounder gun long - -	7. 7½	2. 0	1733
4 Pounder	6. 0½	2. 0	

IV.—TABLE of the Weight of Brass Guns used in the French Land Service, in 1794, and the Weight of the Head with which they are Cast.

	Length from the extrem. of Pom-mel to extre-m. of Muzzle.	Weight of the Gun.	Weight of the Head.
		lb.	lb.
24 Pounder } Battering	10 10½	5628	3100
16 Pounder } guns	10 4½	4111	2600
12 Pounder } Garrison	9 9½	3184	1800
8 Pounder } guns	8 9½	2175	1200
12 Pounder } Field	7 0½	1808	1233
8 Pounder } pieces	6 1½	1186	950
4 Pounder } pieces	4 10½	590	583
1 Pounder } For light troops	3 10	266	250

(v.)

CAPILLARY ATTRACTION. We had intended, in this place, to examine at some length the different theories which have been proposed in this branch of Natural Philosophy; but we find that we must defer this inquiry till we reach the article **TUBES, CAPILLARY.**

CAPMANY (D. ANTONIO DE), one of the most eminent of the later writers of Spain, was born in Catalonia in 1754. He lived for a considerable time in Barcelona, and latterly in Madrid, where he died in 1810. He ranks high both as a general scholar, and as a political writer, and has, indeed, in the latter character, manifested much more sound and extensive views than belong to most of his countrymen. In particular, it is to be remarked of him, that he is almost the only native who has endeavoured to expose the exaggerations of the earlier writers in regard to the immense population, and highly advanced state of agriculture, commerce, and manufactures, in that country, in former times. His principal works, as noticed in the *Biographie Universelle*, and *Dictionnaire Universel*, are as follows: 1. *The art of translating the French into the Spanish language.* 1776, in 4to. 2. *The Philosophy of Eloquence.* 1777, in 8vo. 3. *History of the Marine, Commerce, and Arts of the ancient City of Barcelona.* The two first volumes of this work were published in 1779; the two last, which consist of a variety of curious and important documents copied from the archives of Barcelona, in 1792. "This excellent work is marked throughout with a spirit of liberality and good sense, and distinguished by an attention to philosophical and general views, but seldom displayed by those who ransack archives, and compile papers for the use of future historians. We consider it a most valuable addition to the history of the commerce and manufactures of the middle ages." (*Edinburgh Review*, Vol. X.) 4. *Historical and Critical Theatre of Spanish Eloquence.* 1786—94. 5 vols. 4to. 5. *A Dictionary, French and Spanish.* 1805, in 4to. This dictionary is prefaced with a critical examination of the two languages.

Besides these, and some other pieces, noticed in the Biographical Dictionaries already mentioned, there is a collection of tracts by Capmany, not alluded to in either of them, entitled *Questiones criticas sobre varios Puntos de Historia Economica, Politica y Militar*, published in 1807, and of which there is an interesting account in the tenth volume of the *Edinburgh Review*. All Capmany's works were published in the Spanish language, and we are not aware that any of them has been translated into any other tongue.

CARACCAS, an extensive province of South America, forming part of the Spanish dominions in that country. It comprehends five other subordinate provinces or governments; namely, the province of Venezuela in the centre, the government of Maracaibo on the west, Guiana on the south, the government of Cumana on the east, and the Island of Margaritta on the north-east. It is bounded on the north from the Cape de la Vela to the point of Paria, by the Carribbean sea; on the east by the Atlantic from the 12th to the 8th degree of north latitude;

Caraccas. on the south by Dutch Guiana and Peru, and on the west by the kingdom of Santa Fé.

imate. This country, extending from the 12th degree of north latitude towards the equinoctial line, might be expected, from its geographical position, to be subject to the utmost violence of the tropical heats, and to be reckoned almost uninhabitable by a scorching sun. But throughout the whole continent of America, the general law of the climate is modified by the elevation of the ground; and, owing to this circumstance, the inhabitants of many parts of the Caraccas enjoy the temperature of perpetual spring. For this happy singularity in its climate, the province of the Caraccas is indebted to a chain of the Andes, which, commencing near the province of Quito, traverses the country in its whole extent, and, gradually diminishing in height in its progress to the east, finally loses itself in the Island of Trinidad. This chain of mountains, which varies in breadth from ten to twenty leagues, is generally of moderate elevation. In some points it rises to the height of 8000 feet, but its average height is not more than 4500 feet above the level of the sea. These inequalities of height give rise to a corresponding diversity of temperature; owing to which the vegetable productions of distant countries, here meeting with a congenial climate, are frequently found concentrated within a comparatively narrow compass. At intervals rich valleys open, and the sides of the mountains are covered with the finest trees. In travelling into the interior from the coast, the European experiences a great and enlivening change from the hot air of the low countries to the pure and cool atmosphere which prevails in these mountainous regions. The city of Caraccas, according to Depons, is 3000 feet above the level of the sea, and though it is situated in 10° 31' north latitude, so far from being oppressed by the insupportable heats of the torrid zone, it enjoys the mild and temperate climate of the southern countries of Europe. The highest range of the thermometer in summer is 85°, and in winter 76°, and the minimum of heat in winter is 52°.

To the south, these mountains are bounded by the valley of the Orinoco. The country is here extended into immense plains, known by the general name of *Las Llanos*. Those plains afford pasturage to innumerable cattle, the proprietors of which reside in the towns, leaving them to the care of slaves or people of colour. This race of men, accustomed to be almost continually on horseback, and being almost in a state of nature, in these immense and uninhabited plains, contract the most disorderly and lawless habits. Many of them are professed robbers; they are already beginning to form themselves into bands, and to infest the roads, so as to render travelling dangerous. In these plains the heat is intense, the thermometer frequently rising to 110 and even 115 degrees.

seasons. The seasons here are divided into winter and summer, which are not so much distinguished by cold or heat, as by rainy and dry weather. The rainy season commences generally in April and continues till November. These rains are not, however, without intermission. There are some days in which no rain falls, and there are others, though they are not frequent, in which it rains incessantly. It may

be calculated that, during the rainy season, it rains, on an average, three hours each day, and oftener in the morning than in the evening. The long continued and drizzling rains of the polar regions are not known here. But notwithstanding of this, the rains which in the torrid zone rush down with the violence of a torrent, produce in one hour about six times the quantity of water which is ever known to fall in Europe within the same space. During the rainy season, the rivers are consequently in a continual state of inundation; the channels which, during the rest of the year, remain parched and dry, are now filled with overflowing streams; and the plain through which flows the Orinoco, is inundated by a sea of fresh water for a space extending 150 leagues in length and 40 in breadth.

For about a century after the acquisition of *Terra Firma* by the Europeans, no attempt was made to raise any sort of produce from the soil. Gold and silver were the great objects of research, and the pursuit after these superseded every other species of industry. The adventurers, however, who settled in the country, not finding a sufficient quantity of the precious metals to gratify their rapacity, turned their thoughts towards the pearl fisheries. Being speedily disappointed in their expectations of wealth from this source, they had recourse to agriculture, and, on trial, they found the soil of the Caraccas extremely fertile, and capable of producing ample returns. They began with cultivating cacao, plantations of which were multiplied throughout the country, and the labours of the planter were so admirably seconded by a favourable soil, that the produce was both abundant and of an excellent quality. Cacao was almost exclusively cultivated till a very late period. About the year 1774, the culture of indigo was begun, and it was speedily ascertained, that the soil was equally well adapted to raise this valuable produce. Most of the new plantations were, therefore, prepared for this new species of culture, and immense plains, till then uncultivated, were covered with plantations of indigo. The profits derived from this trade, and the great concourse of traders and cultivators, occasioned villages to spring up in the desert, and gave to many towns, such as Maracay, Tulmero, and Victoria, which were before in a state of decay, the aspect and consistence of cities. About the same time the cotton plant was introduced. The cultivation of sugar, tobacco, and generally of all the other products of the tropical regions, was also commenced. In this fine country, however, blessed as it is with all the advantages both of soil and of climate, agriculture still languishes. There is a want of enterprise and active industry among the planters;—their plantations are committed to the care of ignorant overseers; and the Spanish proprietor, who generally resides in town, seldom visits his estates above once in a year. This carelessness frequently produces embarrassments; the land is mortgaged for the purpose of raising money, and the capital which ought to be laid out in improved cultivation, is thus forestalled for the purposes of extravagance. "It is a matter of astonishment," says Depons, "that in the most beautiful country in nature, where everything concurs to promote luxuriance of vegetation, the plantations should be so inconsider-

Caraccas.

Caraccas. able in magnitude. A planter, whose income amounts to 4000 or 5000 dollars *per annum*, is considered rich. There cannot be enumerated twenty plantations in the Caraccas which yield a greater revenue. It is not, however, that the property is too much divided. It is rare to see a plantation of one-tenth part of its extent is cultivated. It is a cheerless and painful sight to behold the labour of three successive centuries crowned with such pitiful results. On a soil two hundred times less spacious, incomparably less watered, and less fertile, and with not more than one-half the white population, the French have succeeded in raising, at St Domingo, ten times more produce than is raised at this day in the vast province of the Caraccas."

Abundance
of Wood of
various
kinds.

Besides the colonial commodities already enumerated, this country produces vanilla, wild cochineal, gums, resins, roots, barks, and plants, many of which are prized for their medicinal virtues. In the mountains of the interior are found the same kinds of wood as in the Antilles, and many other kinds peculiar to the country. The vast forests by which the country is covered, contain abundant supplies of timber for the most extensive ship-yards. All those inexhaustible resources are, however, useless, owing to the difficulty of transporting the wood over the trackless paths of the mountains. These difficulties might be considerably diminished, if due exertion were made to clear the channels of the rivers from occasional obstructions, so as to facilitate the intercourse with the interior. But there is neither enterprise nor industry in the country adequate for such improvements. Besides large timber for the construction of vessels and other purposes, their forests contain materials for the work of the carpenter and cabinet-maker, so various, as to embarrass them in their choice. The beams and joists of houses are, in general, made from the wood which the Spaniards call Pardillo, and in some places they use a species of very hard oak. Cedar is used for doors, windows, tables, &c.; and, for ornamental furniture, they have several kinds of wood susceptible of the highest polish. Among these is distinguished the black ebony, found in great abundance in the forests in the neighbourhood of Lake Maracaibo. Yellow and red ebony is also common; but mahogany is not so abundant as in the West India islands, and it is, besides, inferior both in respect to its shades and gloss. Iron wood, which abounds in different parts of the country, is used for shafts to the wheels of water-mills; for the rollers of the cylinders used for pressing sugar-canes; and, generally, on all occasions for which wood of extraordinary hardness is required. The red ebony is also applied to the same uses as the iron wood, and is even thought to surpass it in hardness. No wood has yet been found fit for dyeing, except the Brasil wood. But the immense forests which overspread the mountainous parts of this country have not been explored to any extent. They still continue, for the most part, to be the exclusive domain of ferocious animals and venomous reptiles, and we cannot be certain, until they are more fully known, what hidden resources they may afford for the extension of commerce, or the improvement of art.

On the first discovery of *Terra Firma*, the pearl-fishery formed a considerable branch of trade as well as of revenue. The *pearla ronde* was found to abound in the shoals which extend from Cape Paria to that of Vela; and the island of Margareta, Cubagua, Coche, Punta Araya, and the mouth of the Rio la Hacha, were celebrated for the quantity of pearls which they produced. The fifth of the produce was claimed by the king, and it was estimated in the beginning of the 16th century to amount to about 15,000 ducats, which, considering that an extensive contraband trade was at the same time carried on, shows the whole amount to have been considerable. Till the year 1530, the annual value of the pearls sent to Europe amounted on an average to 800,000 piastres. Towards the end of the 16th century, the produce of the American pearl-fisheries diminished rapidly, and, according to some accounts, they were altogether abandoned by the year 1683. Various causes were assigned for the decline of this trade. But the chief cause seems to have been the increasing scarcity of the oysters which yielded these precious stones. With such persevering rapacity was this lucrative trade pursued, that the shells were destroyed faster than they could be multiplied. It is known that the animal which inhabits the pearl-shell does not live above nine or ten years, and it is only in the fourth year that the pearls begin to show themselves. Of these shells, a boat will collect in about two or three weeks more than 35,000. At Ceylon, the government only permits the pearl-fishing to be continued for one month in the course of a year; but on the coasts of the Caraccas there was no restriction. The pearl banks were fished at all seasons, and the consequence is, that they have been abandoned for nearly two centuries. At Cumana it is supposed, that, during such a long period of reprieve, the pearl-shells must have been greatly increased; and, in 1812, some attempts were made to revive the fishery. But it is generally observed, that the few pearls which are now accidentally found are both extremely small, and devoid of brilliancy, while those found among the Indians on the arrival of the Spaniards on *Terra Firma*, were particularly distinguished for these two properties. It is difficult to account for this change. Humboldt conjectures that the earthquakes to which this country is peculiarly subject, may have altered the bottom of the sea, or that the changes in the submarine currents may have so far influenced the temperature of the water, as to diminish the sustenance necessary for the support of the animal which produces the pearl. The small pearls which are still occasionally found on the coasts entangled in the fishermen's nets, are sold to the retail dealers of Cumana, at the ordinary price of a piastre, or 4s. 2d. *per* dozen.

Mineral springs abound in these provinces, both warm and cold; and they are of various qualities, namely, the ammoniacal, the ferruginous, the nitrous, and the acidulous. Some of these waters have a degree of heat which nearly approaches to that of boiling water. Owing to their situation, however, generally in uninhabited places, far from any frequented path, they are not of the same advantage to medicine as if they were differently situ-

raccas. ated, because the patient cannot enjoy the benefit of those waters, and, at the same time, all those domestic comforts which are equally necessary to his recovery. He must sacrifice the one to procure the other; so that, in many cases, the disadvantage of the change is greater than the benefit.

halt. All that portion of the coast which is north of the province of Venezuela, furnishes a considerable quantity of salt, of a beautiful whiteness. But the most abundant salt-pit is that of Araya, which consists of a mixture of the fossil and marine salts. Its produce, under the regime of the mother country, was monopolized for the benefit of the Crown, the consequence of which was, that the working of the pits was little attended to, and that they did not yield anything like the quantity of salt which, under better management, they were capable of producing.

kes. The aspect of this country is agreeably diversified by lakes and rivers. Of the lakes, those of Maracaibo and Valencia are the most deserving of notice. The lake of Maracaibo is of an oblong form, lying north and south, and communicating by a narrow neck with the sea. Its length, from the bar to its southern extremity, is 150 miles. Its greatest breadth is 90, and it is 450 miles in circumference. It is navigable for vessels of the greatest burden; and though it is not liable to tempests, there is always an undulation on its surface; and when strong breezes blow, more especially from the north, its waves become sufficiently agitated to bury under them canoes and small craft. Its waters are, in general, fresh and fit for drinking; but, at times, the waters of the sea are forced, by means of storms, towards the lake, and it then becomes brackish as far as the town of Maracaibo. All the different species of fish which are found in the rivers of South America, with the exception of the tortoise, abound in this lake; but the general sterility of the adjacent country, and the unhealthy atmosphere which is occasioned by noxious exhalations from its waters, are unfavourable to the progress of cultivation; so that the Indians, in place of making their abode on its shores, have generally dwelt on the lake itself, in wooden huts, constructed for the purpose. To the north-west of the lake is an inexhaustible mine of mineral pitch, which is of so inflammable a nature that during the night, and especially in hot weather, phosphoric fires are continually seen, which have the appearance of lightning. These fires are known by the name of the *lanterns of Maracaibo*, and they serve as a light-house and compass to guide the course of the Spaniards and Indians who are navigating the lake.

The lake of Valencia, though not of the same magnitude as Lake Maracaibo, presents a far more agreeable and interesting spectacle. Its shores, in place of being arid and unhealthy, are clothed with all the luxuriant vegetation of the tropical regions, and the temperature is mild and salubrious. This lake is about one league distant from the city of Valencia, and about 18 miles from the sea. It is of an oblong form, stretching north-east and south-west, and is about 40 miles in length, and about 12 in the broadest part. It is situated in a valley surrounded with high and inaccessible mountains, ex-

cepting on the west, where it extends into the interior; and it receives the waters of twenty rivers, without any visible outlet. This circumstance has given occasion to the conjecture, that its waters must be discharged by a subterraneous passage; and, in confirmation of this hypothesis, it is stated by Depons, that the boats which navigate the lake sail with rapidity from the shores to the centre, but that it requires longer time and greater exertion to return from the centre towards the shore. How far this conjecture is well-founded, seems extremely doubtful. The contributions from so many rivers may be no more than sufficient to supply the drain occasioned by the constant and intense evaporation of a tropical sun; and, at any rate, until this question is determined by accurate investigation, it seems idle to have recourse to the supposition of subterraneous channels to account for what may be the result of more obvious causes. One fact is certain, that, of late years, the waters of the lake have experienced a considerable depression, and they still continue receding within a narrower space. This is sufficiently accounted for by the progress of cultivation throughout the country, in consequence of which the cultivators draw an increased supply of water from the streams which flow into the lake, in order to irrigate and refresh their different plantations. In proportion as the waters recede, tracts of ground are left uncovered, which, having received for centuries past the deposited slime and substances of the lake, have thence acquired a prodigious fertility. These spots are eagerly selected for cultivation, and they reward the labours of the planter with a large return. The eastern shores of the lake are laid out for the culture of tobacco in five plantations, which occupy 15,000 persons, and the remainder of the lands which surround it are employed in raising other productions peculiar to the country. The woods in the vicinity afford a haunt to numerous varieties of birds, which are equally distinguished by the brilliancy of their plumage, and the melody of their notes. Reptiles are also common. Among these are two species of lizards, which are considered by the Indians and Spaniards as delicious food, and which are eagerly sought after. The waters of the lake are thick and of a nauseous taste, which is ascribed by Depons to the putrefaction of animal and vegetable substances. Its surface is diversified by numerous islands, by which its navigation is somewhat impeded. Most of these are inhabited, and yield abundance of provisions, fruits, and vegetables.

The abundant rains, which fall in the Caraccas, Rivers. find their way to the ocean by a variety of channels, and there is, accordingly, no country which is watered by more numerous streams. Every valley has its rivers, and if they are not all of sufficient size to answer the purposes of navigation, they afford ample supplies of water for the necessary purpose of irrigating the grounds which are cultivated along their shores. All the streams which rise on the northern ridge of the mountains in the interior run from south to north, and fall into the Carribean Sea, while those which have their sources in the southern declivity of the same range of mountains, traverse in a southern direction the whole ex-

Caracas. tent of the intermediate plain, till they reach the majestic stream of the Orinoco. The principal rivers which flow northward into the Carribean Sea are the Guiges, Tocuyo, Aroa, Yaracuy, Tuy, Unara, Neveri, Manzanares. These are so strongly fenced in by the natural barriers of high banks, and the ground at the same time forms such a continued declivity, that they seldom overflow the adjacent country to any extent, so as to occasion damage. The most considerable rivers which fall into the Orinoco are the Mamo, the Pariagon and Pao, the Chivata and Zoa, the Cachimamo, the Aracay, the Manapira and Espino, and, lastly, the great river Apure, which enters the Orinoco by several channels. This river receives an immense variety of smaller streams, and is, indeed, the only channel by which all the lesser rivers, which rise in the extensive tract of country through which it flows, are conveyed to the Orinoco. During the rainy season, its waters, near its mouth, are spread over the flat country, which it traverses to an extent of nearly 96 miles; and, in general, all the rivers of this province, which flow through level grounds, overflow, during part of the year, a large tract of the adjacent country. This inundation covers a larger space as the rivers approach the ocean. Near the mouth of the Orinoco, one vast sea of fresh water is spread over the country to an extent, according to Depous, of nearly 200 leagues. The rise of the rivers commences in April, and ends in August, and during the subsequent month of September, there is no perceptible fall in the waters of the Orinoco. About the beginning of October they begin to retire from the flat country, and by the end of February the river has reached its lowest point.

Commerce of this Colony, and Policy of the Mother Country.

In the settlements which they established in different parts of South America, the Spaniards, it is well known, were actuated solely by the desire of procuring the precious metals, and every other less valuable produce was regarded as unworthy of consideration. Under the influence of this spirit, the first adventurers in *Terra Firma* directed all their researches, as we have already observed, to the discovery of mines. These, however, proved so unproductive, that they were soon abandoned, and the colonists were, in this manner, compelled to have recourse for their subsistence to the cultivation of the soil. But it does not appear that their early efforts were favoured by the superintending care of the mother country. No Spanish vessel ever approached the desert shores of this new settled colony; and it was only at the special request of the colonists, that one vessel from the mother country was annually freighted to this part of America, to supply them with the necessaries of life. In this languishing state, the Caraccas continued during the whole of the 16th century. The faint hope of discovering mines, joined to the prosecution of the pearl fishery, which was at this time carried on with singular perseverance and cruelty, still continued to stifle every idea of agricultural industry; and it was not till the year 1634, when the Dutch took possession of the island of Curacao, that the inhabitants of *Terra Firma* were encouraged, by

the vicinity of those industrious settlers, to devote their attention to agriculture, for the purpose of providing themselves with the means of commercial exchange. Cacao and hides constituted for a long period the two staple articles which they exchanged with the Hollanders for such other commodities as they were in want of.

The commencement of a trade with foreigners, however inconsiderable, excited the jealousy of the mother country, which, though it gave no reasonable aid to the early efforts of those colonists, was resolved to claim the dominion over them, as soon as their industry could be made subservient to its profit. Two vessels were accordingly allowed to sail from Spain, freighted with merchandise for the colonies, on which enormous duties were charged. The consequence was, that the Spanish merchants were undersold by the Dutch traders, and those foreigners were left during the remainder of the century in quiet possession of the trade, which was carried on both more openly and to a greater extent. During the first thirty years of the subsequent century, the intercourse with Spain was revived; but the trade with the mother country bore no proportion to the contraband trade. The annual produce of the province amounted to 65,000 quintals* of cacao; the legal exports were estimated at 21,000 quintals, so that 44,000 quintals still remain for the contraband trader. The Spanish Government, viewing with increasing dislike the growing connection of its colony with foreigners, resolved to stop the intercourse by the violence of power; and, with this view, confiscations, fines, and the most degrading punishments, were inflicted on those who engaged in it. Numerous families were ruined by these severities, but the trade continued as before. It originated in the necessities of the country, and such encouragements to evasion were held out, as covered all the risks of detection.

These violent measures not being found to answer their intended purpose, several Biscayan merchants offered to the government, in 1728, to destroy the contraband commerce, on condition of being allowed the privilege of supplying the wants of the colony, and of exporting its produce. To this proposal the government acceded, after imposing several burdensome conditions on the company. These, however, were complied with, and with such activity, prudence, and economy, were the affairs of the company carried on, that they succeeded in supplanting the contraband trade, while their management gave complete satisfaction to the colonies. From the year 1730 to 1748, 858,978 quintals of cacao were shipped from the colonies to the mother country, which amounted to one-third more than had been exported for the last thirty years. In 1742, the company had acquired such credit with the government, that they applied for and obtained the monopoly of the colonial trade. Great jealousies were excited in the colonies by this concession; and to appease the universal discontent which prevailed, it was agreed, in 1750, that a board should be appointed, composed of an

* A quintal is 1600 ounces.

Caracas. equal number of members of the company, and of cultivators in the colony,—the Governor-General to be President, who should regulate the prices at which the colony and the company should respectively exchange their merchandise. It was, at the same time, permitted to those planters who were not satisfied with the established price, to send one-sixth part of their cacao to Spain, on their own account, and in the vessels of the company. Under this regulated monopoly, the colonial trade was carried on with less of injustice to individuals than might have been expected, and with great prudence and success. For the destruction of the contraband trade, the company maintained, at an annual expence of 200,000 dollars, an armament of ten vessels, which carried 86 guns and 518 men; besides, 102 men employed on shore. Superb warehouses were constructed in the different ports to which its vessels traded, for the accommodation of its agents; and advances, without interest, were made to different planters to the amount of 640,000 dollars, on the security of the produce of their estates, at a fixed price. By the encouragement thus given to the trade of the colony, cultivation was extended,—flourishing villages arose in different parts,—and in addition to cacao, formerly the only staple of the country, other species of colonial produce were now cultivated. About the year 1735, the whole cacao produced in the province was estimated at 65,000 quintals, while, in 1763, there were embarked,

	Quintals.
For Spain,	50,319
Vera Cruz,	16,864
the Canaries,	11,160
St Domingo, Porto Rico, and Havannah,	2316
Local consumption,	30,000
Total,	110,659

During the same period the cattle multiplied rapidly on the extensive plains which stretch to the south of Caraccas, and hides were added to the other articles of exportation. By the increase of cultivation and trade, the various duties, which were hitherto insufficient to defray the expences of government, became perfectly adequate to every charge; and the government of the mother country was freed from the burden to which it had been subject for a

Caracas. period of 200 years, of sending remittances from Mexico, for the purpose of supporting the civil and military establishments of Venezuela.

Such were the beneficial effects produced by the moderate and prudent conduct of the Company. It was evident, however, that no security existed for the continuance of this good management, farther than the discretion of the directors, who, in process of time, were corrupted by the temptations held out to them; and, in place of trading with the colonies upon the equitable principles of commercial exchange, became eager to obtain all the unfair advantages of the most rapacious monopolists. Bribery was resorted to, in order to procure a regulation of prices favourable to their interests,—the duties were evaded,—the contraband trade was encouraged,—and by all those transactions the planters were injured, while the mother country was deprived of the trade which the Company had engaged to carry on for her benefit. The natural remedy for these abuses was a free trade. A regulation was accordingly issued in 1778, by which all the chief ports of the Caraccas and of Spain were reciprocally opened to each other's produce, and the trade between them was, in effect, declared free. A scale of duties was at the same time established, by which the articles exported to the colonies were divided into three classes. The first of these consisted of articles the growth or manufacture of Spain, which were charged at the lowest rate, namely, 9½ per cent. on leaving Spain, and the same on being landed in America. All goods, likewise, of which the value was doubled by domestic industry, were placed in the same class. In the second class were comprehended such articles as had received a certain augmentation of value from domestic industry, but not such as to raise their value one half. These paid, on their shipment to the colonies, and on their arrival, 12½ per cent. The third class of articles, which were of foreign workmanship, were liable to a duty of 22 per cent. on leaving Spain. The colonial produce, on its importation into Spain, was made subject to moderate duties.

From the year 1793 to the year 1796, and from 1796 to 1800, Depons, in his account of the Caraccas, gives the following comparative statement of the value of the produce exported.

Exportations from 1793 to 1796.

		Dollars.
367,819 quintals cacao, at 18 dollars,		6,620,742
2,955,963 lbs. indigo, 12 reals,		5,172,987
1,498,332 lbs. cotton, 20 reals,		299,666
1,325,584 lbs. coffee,		159,070
		12,252,415.

Exportations from 1796 to 1800.

		Dollars.
239,162 quintals cacao, at 18 dollars,		4,304,916
793,210 lbs. indigo, 14 reals,		1,386,117
2,834,254 lbs. cotton, 20 dollars,		566,850
1,536,967 lbs. coffee,		184,435
		6,442,318

Diminution on the four last years, 5,810,097

Caraccas.

This diminution of exports is ascribed by Depons to the defects of the internal administration, and partly also to the war which, after this period, was begun between Great Britain and Spain. This writer does not specify particularly the faults to which he alludes; but, in the mean time, no such change had taken place in the domestic administration of the country, as will account for such an enormous defalcation in the value of the produce exported. The war between Britain and Spain appears to be the most probable and satisfactory cause of this diminution. By that event, the whole colonial trade of Spain became the prey of the British cruisers; and such was their unremitting vigilance, that the intercourse between the colonies and the mother country was almost entirely interrupted. In these circumstances, the rigour of the colonial monopoly was relaxed; the ports of the colonies were thrown open to neutrals; and, in addition to this intercourse, a contraband trade, to a great extent, was carried on with the British colonies. But of this illicit traffic no return would of course be made in the general account of the colonial trade; and it is possible, therefore, that the apparent defalcation of exports pointed out by Depons may have arisen from the circumstance of an illicit having taken the place of a contraband trade. In the year 1800, the Court of Spain, swayed by the selfish representations of the Spanish merchants, revoked the liberty granted to the colonies of trading with neutrals; and the consequences of this order were injurious in the extreme, and would have been ruinous to the colonies, had they not resorted, as before, to the necessary remedy of the contraband trade. This trade was carried on to a great extent with the British colonies, and was either connived at, or, as was affirmed, was in some cases formally licensed, by the British cruisers. During this period, therefore, and generally indeed during the whole course of the war, no custom-house account of imports and exports can be considered as affording any accurate view of the foreign trade of this colony.

Revenues.

The public revenues of the Caraccas arise from various taxes, namely, from the alcavala, which is a tax of 5 per cent. collected on all sales, whether of moveables, or of landed property. Every species of merchandise or territorial production is made subject to this impost, the moment it is exposed to sale; and retail dealers are in the habit of compounding with the Government, by the payment of an annual sum on their whole stock. This tax produced, in 1798, 150,862 dollars, and, in 1797, only 10,248, owing to the suspension of maritime commerce. A revenue is also derived from export and import duties, from duties on all distillers of intoxicating liquors, and on the shops where they are sold; from the sale of titles and offices, from stamps, from the sale of bulls granting spiritual indulgencies, from the monopoly of tobacco, and from various other local imports. The tithes, which are rigorously levied throughout the Caraccas, form a branch of the public revenue; two-ninths belonging to the Crown, and the remaining seven-ninths being appropriated to the payment of the ecclesiastics, and to the building and upholding of religious edifices.

The cargoes exported from Spain to the Caraccas do not, generally, contain above one-fourth of Spanish produce and manufactures, the other three-fourths being supplied chiefly from Britain, France, the Hanse Towns, and part occasionally by Italy. The articles in the greatest demand at the Caraccas are linens, laces, black stuffs, principally serges, prunellas, satins, and taffeties. These are used for the cassocks and mantles of the priests, and for the dresses used by the women in their devotional exercises. Thick cloths are also in demand, and most of the whites are dressed in cassimere or in French cloths. Hats are also a saleable article, and French hats are universally preferred to those manufactured in other countries. No round hats are worn except by the lowest classes, or by boys, all the civil and military officers wearing cocked hats. A considerable quantity of boots, for the wearing of which the young Spaniards have acquired a taste, have been lately imported from the British colonies, and have met with a ready sale. As the shoemakers of the country cannot imitate the fashion and the make of these articles, the importer is free from competition, and he is therefore enabled to charge a high price. Shoes, however, are made in the country of a sufficiently good quality, and at a moderate price. They do not, therefore, form so profitable an article of importation. Among the coarse goods, the linens of Brittany, Rouen, Morlaix, and of Russia, are universally used.

The population of the Caraccas is stated by Depons to amount to 728,000, and he assigns the following proportions to the different provinces:

To the province of Venezuela, including		
Varinas, a population of	-	500,000
To the Government of Maracaibo,	-	100,000
To that of Cumana,	-	80,000
To Spanish Guiana,	-	34,000
To the Isle of Margaritta,	-	14,000
		728,000

Of this population the whites form two-tenths, the slaves three-tenths, the descendants of freedmen four, and the Indians compose the remainder. Some writers are of opinion that this account of the population is rather exaggerated.

The principal towns of the Caraccas are, Caraccas the capital, containing 34,000 inhabitants, Cumana 24,000, Porto Cavello 7500, Valencia 6500, Maracay 8400, Guayra 6000, Tulmero 8000, Victoria 7800, Coro 10,000, Carora 6200, Barquisimeto 11,300, Tocuyo 10,000, Guanara 12,300.

This country was first discovered by Columbus in the year 1498, in the course of his third voyage to America. Several attempts were made to settle it by means of missionaries, all of which proved unsuccessful. The natives were at last subdued by a military force, and the management of the Spanish settlements in this province were, for a pecuniary consideration, consigned by Charles V. to a German mercantile company named the Welsers. Under their government, the country experienced the most cruel oppression. The company were, in consequence

Baraccas deprived of the sovereignty in the year 1550, and a supreme government was appointed by the Crown. Since this period, these provinces continued under the government of the mother country, until the year 1810, when Spain was nearly overrun by the armies of France, and when no reasonable expectation could be entertained that she would be able to resist the invading force. In these circumstances, the colonies being aggrieved by useless restrictions on their commerce, and by other oppressions, a strong party was formed, ostensibly to protect them from the yoke of France, but really, it is supposed, with a view to detach them entirely from the dominion of the mother country. At last, on the 4th July 1811, the congress of Venezuela published a formal decree for their independence. A declaration of rights was afterwards issued, and with such severity was the new system enforced, that the jails were crowded with persons suspected of disaffection to the revolutionary measures adopted; great numbers were proscribed; some were banished and imprisoned; others were executed, and their heads stuck upon poles, as examples of terror to others. Several towns, and among others Coro and Valencia, declared against the new system. Troops were immediately dispatched to reduce the former city by force; these were beaten back with considerable loss. General Miranda was at the same time sent against the town of Valencia, and after some sanguinary encounters, he obtained possession of the place, from which, however, he was soon driven with loss by the determined resistance of the inhabitants. Being reinforced, he renewed the attack, and finally succeeded in his object. Since this period, the war between the two parties has been carried on with various success; and, from the latest accounts, it would appear that the cause of the independents is gaining ground. At present we have no information by which we can decide as to the issue of the contest; and we must, therefore, defer any farther account of it till we arrive at the general article of SOUTH AMERICA.

See Semple's *Sketch of the Present State of the Caraccas*, 1812.—*Travels in South America*, by F. Depons, 2 vols. 8vo, 1807.—*Humboldt's Personal Narrative of Travels in the Equinoctial Regions*, 2 vols. 8vo, 1814. (o.)

CARDIGANSHIRE is divided from Caermarthenshire and Pembrokeshire, along the greatest part of its southern side, by the Tivy; on the north it is divided from Merionethshire by the river Dory; and from Montgomeryshire by an artificial boundary. The boundaries on the east, between it and Radnorshire and Breconshire, are also artificial. On the west, it stretches along the sea-coast in a bending line, from north-east to south-west, forming part of the shore of Cardigan Bay. Its extent, measured along the shore, is nearly 40 miles. Its breadth does not average 20. It contains 726 square miles, or 464,640 acres. It is divided into five hundred. The market towns are Aberystwith, Cardigan, Llanbodemrwan, Llanbeder, and Tregaron. The number of parishes, according to the last Parliamentary returns respecting the poor's rates, is 97. It sends

VOL. II, PART II.

one member to Parliament; lies in the province of Canterbury, and diocese of St David's; and is in the North Wales circuit. The coast of Cardigan Bay (which is formed by the projecting counties of Caernarvon on the north, and Pembroke on the south, with the coasts of Merioneth and Cardigan in the centre), according to tradition and appearance, have suffered greatly from the depredations of the sea, especially on the Cardigan shore. The tradition of the country is, that there was formerly a sixth hundred, which is now covered by the sea; and there are still to be seen, at low water, several ridges of rocks, called causeways, which seem to confirm the truth of this tradition. Of these the most remarkable is St Patrick's Causeway, which extends from within a mile of the point of Mochras, south of Harlech, 22 miles into the sea, in a serpentine line. It is formed of rough stones, 24 feet broad; and at the extremity there is a round head, formed of sixteen great stones, one of which is four yards in diameter. Trunks and roots of trees are also found at a considerable distance from the shore.

The principal rivers are the Tivy, the Rydiol, the Rivers. Ystwyth, and the Aeron. The Tivy rises in Llyn Tecfy, or Tivy Pool, in a mountain in the north-east of the county. On the top of this mountain there are five lakes, of which Tivy Pool is the principal. It is about one mile and a half in circumference, is surrounded by high and perpendicular rocks, and is said never to have been fathomed. The Tivy at first flows through a rocky district; afterwards, forming a regular channel, it passes Tregaron; and, at Llanbeder, becomes the boundary between Caermarthenshire and Cardiganshire. It falls into the sea about two miles below Cardigan. The Rydiol rises on the south-west side of Plinlimmon; its course is about south-west; and it falls into the sea near Aberystwyth. About 12 miles above this town is the Devil's Bridge, called by the Welch, Pont y Monach, or the Monks' Bridge, and Pont ar Fynach, from the confluence here of the Fynach with the Rydiol. There are two arches, one above the other. The uppermost is between 20 and 30 feet in the chord; and the other less than 20. The upper one was built in 1758; the date of the building of the lower one is not known. Near this bridge are the falls of the Fynach. The first fall takes place where the river is much confined by the rocks. The water is carried about six feet over them, into a basin 18 feet below. The next fall is 60 feet, the third fall is 20, and the last is 110 feet. Near this is the fall of the Rydiol, the scenery round which is considered very striking and grand. The Ystwyth rises among the hills on the eastern side of the county, and falls into the sea at Aberystwyth. The Aeron is between six and seven miles in extent, receives six tributary streams, and forms, during the whole of its course, nearly the arc of a circle. It falls into the sea at Aberaeron.

That part of the country which lies along the sea Surface and is level, especially the south-western extremity; but Soil. the northern and eastern parts are very rugged and mountainous. The soil of the low lands is either a light or a strong loam, lying on slate. The soil of

4 I

Cardigan-shire. Agriculture.

the mountainous division is in general thin and poor, except in the narrow vallies, where it consists of clay or peat. The tract along the sea coast produces good crops of wheat, barley, turnips, potatoes, and oats. The quality, as well as the produce of the barley grown in some parts of this tract, are very remarkable. Between Aberaeron and Llanrysted, is an extensive flat, extending from the sea to the east mountains, which produces from sixty to eighty bushels of fine barley per acre. This land is constantly under this crop, and has been so for at least half a century. It is manured every three years with sea-weed. Potatoes are grown on the peat mosses in such a manner as at once to secure good crops, and to drain the land. The potatoe sets are laid on the surface of the bog, a little manure is spread over them, and they are afterwards covered with earth dug out of the trenches.

Very few sheep are kept on the low land; but on the mountains they are numerous. They are, in general, the native breed, very inferior both for wool and carcase. Cattle are kept in all parts of the county; in the low lands, and in the vales of the mountainous district, principally for butter and cheese; in the other parts they are bred for the English drovers. Of the 464,640 acres which this county contains, it is calculated that 100,000 are in tillage; 145,000 in pasture, and the rest waste land.

Mines.

Cardiganshire formerly was famous for its mines of lead, but at present they are not very productive; the principal are two, in the vicinity of Cwmysytwith. Near Tal-y-bont are some that used to be very productive, but now are almost exhausted; the matrix of the ore is carbonate of lime. There are also veins of copper, but they are not wrought. The want of coal, of which there is none in the whole county, the rugged nature of the country, and the badness of the roads, are probably the chief causes why the mines are not worked. Near Aberystwith are large slate quarries; the slates lie in alternate strata with shale, and are in compact masses, of a coarse texture; the inclination of the strata varies very much, following the general irregularity of shale. The slate that is found near the sea coast, not being mixed with shale, lies in perpendicular strata. There are some very extensive tracts of peat, especially on the coast beyond Aberystwith, bordering on the river Dovy; and from Strata Florida, near the Tivy, to Llyn y Maes, or the lake of the flood; the latter tract is one continued marshy bog, abounding in Turbaries, as far as Tregaron: according to tradition, a town once stood in this marsh. As connected with the natural history of this county, it may be remarked that Mr Aikin observed near the banks of the Rydiol, a moor-buzzard, and the horse-ant, the largest species of ants that are natives of Britain. The angel-fish is found in the bay of Cardigan.

Slate Quarries.

Peat.

There are few manufactures in this county; at Llechwydol, near Cardigan, are iron and tin works. Black cattle, pigs, butter, barley, oats, flannels, Welsh-webs, bark, iron, tin, slates, and ale, are exported from Aberystwyth, and Cardigan. There is a great fair for cattle and sheep at Rhos, near the source of the Tivy.

Manufactures and Exports.

Cardiganshire is celebrated in the literary history of Wales, for having given birth to David ap Gwylim, who flourished between 1390 and 1370. From the poems of this author, the modern literary dialect of Wales has been chiefly formed, and this dialect is spoken with greater purity in this county than in any other part of the principality.

In Cardiganshire, a custom prevails resembling the penny-weddings among the peasantry of Scotland. Before marriage a bidder goes from house to house, inviting the inhabitants to come to the wedding, and to bring money and cheese and butter. The marriage always takes place on the Saturday, and the guests assemble on the Friday with their presents. All these are set down on paper, that, if demanded, they may be repaid, but this seldom happens. The furnishing of the woman is also brought home on this day. On Saturday, ten or twenty of the man's friends who are best mounted, go to demand the bride, who is placed on a horse behind her father, and rides off as fast as she can. She is soon, however, overtaken. Presents are continued to be received on the Saturday and Sunday; on Monday they are sold, frequently making, with the money presented, the sum of L. 50 or L. 60.

In 1803, the poor's rates amounted to L. 10,167. In 1815, there was collected from 92 parishes L. 15,409, 8s. 6d.

In 1800, the number of houses was 9040, and of inhabitants 42,956. The males were 20,408; the females 22,548. In 1811, there were

Houses inhabited,	-	-	9639
Families inhabiting them,	-	-	11,296
Houses building,	-	-	129
uninhabited,	-	-	155
Families employed in agriculture,	-	-	5864
in trade, manufactures, and handicrafts,	-	-	1913
All others, not comprehended in these classes,	-	-	3519
Males,	-	-	23,759
Females,	-	-	26,501
Total,	-	-	50,260
Population in 1800,	-	-	42,956
Increase,	-	-	7304

See Meyrick's *History of Cardiganshire*.—Mal-kin's *Scenery, &c. of Wales*.—Aikin's *Tour in Wales*. (c.)

CARLOW, the account of which in the *Encyclo-pædia*, under the name of CATHERLOUGH, occupies only a very few lines, lies almost entirely between the rivers Barrow and Slaney. It is about 33 English miles long, from north to south, and about 29 miles broad at its greatest breadth; but it narrows in very much from east to west, between Kilkenny and Wexford. It is divided into five baronies, and into fifty parishes. According to Dr Beaufort, its area is 214 square miles Irish, or 344 English, equal to 137,050 Irish or plantation acres, and 220,098 English acres. The principal towns are

Carlow. Carlow, Tublow, Leighlin-Bridge, Rutland, Palatine Town, Hackets-town, and Gousbridge.

Surface and Soil.

The surface of the greater part of this county is pleasantly undulated; and, with the exception of the high and rough hills which occupy the small portion of it that lies to the west of the Barrow, and the moutainous district in the south-east, on the borders of Wexford, the hills yield little in fertility to the vales. The prevailing soil of the lowlands is a strong fertile loam, mixed with limestone, and incumbent upon it; and that of the uplands is generally a light gravel.

Mr Wakefield gives the following statement of the cultivated and uncultivated land in this county :

Baronies.	Cultivated Land. Acres Irish.	Mountains and Bogs. Acres Irish.
Ruthvilly, -	28,510	
Carlow, -	18,487	
Forth, -	21,601	1937
Idrone, -	38,615	7100
St Mullins, -	16,303	8171
	<hr/> 123,516	<hr/> 12,217

ivers. The principal rivers are the Barrow and the Slaney; the former runs along the whole of the western borders of the county, with the exception of a jutting part of Idrone barony, which it separates from the main body. The Barrow is navigable for barges as far as the town of Carlow, and thence there is a communication with Dublin by means of the Grand Canal. The Slaney, which rises in Wicklow, crosses the eastern part of the county.

Mineralogy. The mineralogy of Carlow is very imperfectly known. The river Barrow seems to separate the soil in this part of Ireland; to the west of it there is limestone in abundance, whereas there is none in Wexford and Wicklow; the best in Ireland is found near Carlow. Marl and a great variety of clays are also found in this county. The mountains, called Black Stairs, from their black appearance at a distance, and their perpendicular height, which separate Carlow from Wexford, are chiefly composed of granite. It also contains iron ore, and a considerable quantity of oxide of manganese. In the time of Charles I. there appears to have been a large iron-foundry near Idof, in which, ordnance, pots, and small round furnaces, were cast. It belonged to Mr Christopher Wandsworth, Master of the Rolls in Ireland, and afterwards Deputy of that kingdom, under the Earl of Stafford (*Natural History of Ireland*, p. 73, Dublin, 1726.) By the same authority we are informed, that the first coal mine was found out in Ireland, a few years before 1726, in the same hill, where the iron mine was. "In that iron mine, after that for a great while they had drawn iron-ore out of it, and that, by degrees, they were gone deeper, at last, in lieu of ore, they met with sea-coal, so as ever since, all the people dwelling in those parts have used it for their firing, finding it very cheap; for the load of an Irish car, drawn by one garron, did stand

them, besides the charges of bringing it, in nine pence only, three pence to the digger, and six pence to the owner."—"These coals are very heavy, and burn with little flame, but lye like charcoal, and continue to the space of seven or eight hours, casting a very great and violent heat." (*Natural History of Ireland*, p. 84.) The same author informs us, that "little smith coals were dispersed every where in great quantity, and had been used by the smiths, even before the mine was discovered." At present, this mine is either forgotten, or not deemed worth working, as the county is chiefly supplied with coals from Kilkenny.

Carlow.

There are no large estates in this county; and very little minute division of property. The hiring tenant is generally the occupier, except of small pieces. The fee has been more transferred here than in any other part of Ireland. Carlow was formerly noted for the extent and luxuriance of its pastures, being one of the greatest sheep counties in the kingdom; but in consequence of the bounty which was granted about the year 1768, on corn conveyed by land-carriage to Dublin, Mr Young calculated that sheep-feeding had declined so much, when he was there in 1776-8, that four farmers had a greater number of sheep twenty years before, than were kept in the whole county at that period. There are still, however, some excellent flocks of large woolled sheep. Four sheep of the Irish breed, and five of the English are called a "collop," and three collops are allotted to two acres of the best land. But it is for its dairies that Carlow is famous; and in this respect, it is not excelled by any county in Ireland. The farmers spare no trouble or expence to procure good cattle for their dairies. From twenty to fifty are generally kept; and, during the season, each cow produces on an average about 1½ cwt. of butter. The dairy system pursued in Devonshire, Dorsetshire, and some of the northern counties of Ireland, of letting cows to dairymen, is followed here; but this custom was more prevalent when the Catholics could not legally purchase land, as they then employed their capital in hiring cows. The butter made in Carlow is divided into three sorts, according to its quality. The first in point of quality is sent to Dublin and England, and thence exported to the East and West Indies. It is highly esteemed in the London market, where it is often sold as Cambridge butter. That of the second quality is exported to Spain, and the worst to Portugal. It is all packed in large casks, weighing upwards of three hundred weight.

From the following statement, given by Mr Young, it appears that the bounty on land-carriage corn soon operated to the increase of tillage in Carlow. No great additional quantity of corn was brought from this county to Dublin till 1769, when the bounty had risen from about L. 150 to L. 849. In the years 1770 and 1771, it declined. In 1772, it rose to L. 1025; and in 1773 to L. 2676. In 1774, to L. 2813. In 1777, the last year Mr Young quotes, it was L. 2479.

There is not, however, much wheat grown, and it is not of a bright colour, or a very good quality.

Carlow
Carlyle.

But the barley of Carlow is excellent; according to Mr Young, the best in Ireland. At the time of his tour, it was the only interior county which produced it; and at present more is grown here than in any other part of the kingdom. It is principally consumed by the illicit distilleries in the north of Ireland, being carried to Dublin by the canal; by the breweries and distilleries at Cork; or by the malting-houses at Wexford. The potatoes grown in Carlow are excellent. There is little or no flax. The county is tolerably wooded. In the vicinity of Carlow, a great many onions are grown, which are sold all over Ireland.

Manufac-
tures.

Carlow is not distinguished as a manufacturing county. In Carlow, coarse cloth, reaping hooks, scythes, shears, &c. are, however, made. At Leighlinbridge is one of the largest corn-mills in Ireland, capable of grinding more than 15,000 barrels a-year.

Population

According to Dr Beaufort, in the year 1792, there were 8763 houses, and 44,000 inhabitants; 15.6 Irish acres to a house; and 40.94 inhabitants to an Irish square mile. The Catholics are reckoned to be ten to one Protestant. The Catholic farmers are becoming wealthy, and have considerable property in leases and farming stock.

In 1792, there were 5503 houses of one hearth; 484 of two; 128 of three; 69 of four; 50 of five; 31 of six; 15 of seven; 8 of eight; 7 of nine; 3 of ten; none were returned above 44; 268 were exempted as new, and 1822 as inhabited by paupers. The total, according to this return, was 8394.

Carlow county sends two members to Parliament, and the town one. The number of registered freeholders of fifty pounds, to February 1815, was 359; of twenty pounds, 295; and of forty shillings, 3263: in all, 3917.

See Young's *Tour in Ireland*.—Beaufort's *Memoir of a Map of Ireland*.—Wakefield's *Statistical Account of Ireland*. (c.)

CARLYLE (JOSEPH DACRE), a distinguished orientalist, and general scholar, was the son of a Physician at Carlisle, and was born there in the year 1759. He received his early education, in the learned languages, at the grammar-school of that city. In 1775 he proceeded to Cambridge, obtained his bachelor's degree in 1779, and was elected a fellow of Queen's College in that University. He left College in 1783, after taking his master's degree, and returned to his native city, where he obtained some church preferment. In 1793, upon the resignation of Dr Paley, he succeeded to the Chancellorship of the Diocese of Carlisle. (*Gentleman's Magazine*, 1804.)

Mr Carlyle had early devoted much of his attention to an accurate study of the Arabic language, in which pursuit he had been assisted by a native of Bagdad, who resided sometime with him at the University. Having thus attained to great proficiency in the language and literature of the Arabians, he in 1792 appeared before the Public as the Translator of an inedited historical work in that language, known under the name of the *Maured Allatafet*. The author of this work was Jemaleddin, a person of the rank of Emir, and distinguished among the Eastern writers by the title of *Historiographer of Egypt*, on

account of his great attention to the improvement of its history. The *Maured Allatafet* is an Epitome, made by Jemaleddin himself, of a larger work, which comprised a complete history of that country, from the first establishment of the Arabian Government, to the eight hundred and fifty seventh year of the Hegira. In reviewing the Epitome with a view to its publication, Mr Carlyle thought proper to retrench that part of it which relates to the Caliphs of Bagdad, their history being, as he conceived, sufficiently illustrated in other writings; so that his publication commences with the first of the *Fatimitic* Caliphs who reigned in Egypt; and it ends, where the original Epitome also terminates, with the reign of Almalec Alashrof, the twelfth of the Circassian race of Sultans, thus comprising a period of nearly five hundred years. However creditable to Mr Carlyle's attainments in Eastern learning, this treatise is not thought to have added much to the stock of historical knowledge, or to suggest any high ideas of the merit of that larger work from which it was abridged, and which procured Jemaleddin so much renown in the East. The title of Mr Carlyle's publication is as follows: *Maured Allatafet Jemaleddini, filii Togri Bardii, seu rerum Egyptianarum Annales, ab anno Christi 971, usque ad annum 1453. E Codice MS. Bibliothecæ Academicæ Cambrigiensis. Arab. et Lat. 4to.*

In 1794, Mr Carlyle was elected Professor of Arabic in the University of Cambridge; and, in 1796, he gave to the world another, and more pleasing proof of his zealous endeavours to illustrate the literature of the East, in a work entitled, *Specimens of Arabian Poetry, from the earliest time to the extinction of the Caliphate, with some Account of the Authors*. Arab. and Eng. 8vo. His object was, by arranging the pieces in chronological order, and accompanying each with some account of the author, and of the occasion of the composition, to exhibit a sort of history of Arabian poetry, during the most splendid period of the Mohammedan empire. Many of these pieces possess considerable beauty; but as Mr Carlyle had it in view to exemplify the different species of poetic composition, he has accordingly translated some specimens, in which he was himself sensible there was nothing to be prized, either in the thought or the execution. Like most of those who have become eminent in Eastern learning, Professor Carlyle is thought to have formed too high an estimate of its merits; but all must admit that his *Specimens*, with their prefaces, form an elegant and interesting work; one which, to use his own words, cannot but prove acceptable to "those who wish to gain an insight into the history of manners, and who love to trace the operations of the human mind in distant countries and various situations." A second edition of this work was published in 1810.

When the Earl of Elgin was appointed Ambassador to the Porte, in 1799, Professor Carlyle was invited to accompany him as an accredited agent of the British government, for the purpose of literary research; and in that capacity he accordingly proceeded to the East. After remaining some time in Constantinople, he left that capital in January 1800, and proceeded through Asia Minor and Cyprus to

Carlyle
|
Carpentry.

Carnatic
|
Carpentry.

Palestine; in which tour he was employed till the following July, when he returned to Constantinople. He again quitted this city in March 1801, and visited the Troad, the convents of Mount Athos, and several parts of Greece. He appears to have spent three weeks amongst these celebrated convents, where, being furnished with recommendations from the Government, and the Patriarch of Constantinople, he was received with marked kindness, and enjoyed every opportunity for literary research. From Athens, where he spent some time, assisted in his inquiries by the artists employed by Lord Elgin, he proceeded in a Ragusan vessel to Malta, and afterwards to Naples, where he arrived in July 1801. He soon thereafter set out for England, and reached his native city early in the month of October. (*Addenda to the REMAINS of John Tweddall. 1816. 4to.*)

Soon after his return, he was presented by the Bishop of Carlisle to the living of Newcastle-upon-Tyne; but which he did not long enjoy; for he fell into bad health, and died in the prime of life, in April 1804 (*Gent. Mag. 1804*). His premature death cut short some useful literary undertakings, and deprived the world of the full fruits of his observations on many interesting scenes, which he had surveyed with the eye of a scholar and the feeling of a poet; for all that the public has derived from his travels, is a posthumous volume of poems, with remarks suggested by these scenes, and which, though bearing testimony to his learning and taste, is but a poor substitute for such a work as, with his knowledge and means of information, he could not have failed to produce. The title of this posthumous volume is as follows: *Poems, suggested chiefly by scenes in Asia Minor, Syria, and Greece, with Prefaces extracted from the Author's Journal.* It was published in 4to, in 1805, and is embellished with some fine engravings.

CARNATIC, the name of an extensive maritime province on the eastern side of the peninsula of India, which, according to Mr Hamilton's *East India Gazetteer*, stretches from the 8th to the 16th degree of north latitude. In Dr Heyne's *Tracts on India*, it is said to extend from the 10th to the 15th degree. The average breadth of this tract is about seventy-five miles. It comprehends the former dominions of the Nabob of Arcot, which were transferred to the East India Company, by a treaty concluded in 1801.

The Carnatic is reckoned one of the hottest portions of India. The soil varies, but is generally sandy,

and in many parts water is scarce, the supplies being wholly derived from what is preserved in tanks filled during the periodical rains. There are, however, some rivers which flow through the country from the high mountains called the Ghauts. In the inland parts, there are large spots of salt ground, containing, says Dr Heyne, either common salt, or a mixture of that salt and soda, which, from the use to which it is applied in India, is known by the name of *Washermen's earth*. Rice constitutes the principal produce of this country, and in those places where water is scarce, great labour is employed to obtain the necessary supplies for the rice fields. The cultivators raise four different crops in the year, two of them from the same ground. In good seasons the first crop produces fifty fold. Sugar is cultivated, but in very small quantities, the soil not being rich enough for the cane. The indigo plant might be cultivated to advantage, if the demand for it were greater. The common *dwarf cotton* is cultivated on the coast, but not extensively.

The capital of this province is MADRAS, of the present state of which city we shall give some account when we reach that head. The other principal towns are Tanjore, Trichinopoly, Madura, Tranquebar, and Negapatam, in the division called the *Southern Carnatic*; Madras, Pondicherry, Arcot, Wallajahbad, Vellore, Cuddalore, Ginjee, Pullicat, Chandgherry, and Nelloor, in the *Central Carnatic*; and Ongole, Carwaree, and Samgaum, in the *North-ern Carnatic*. Vellore is well known as one of the principal stations of the Company's forces. The sons of Tippoo Sultan were placed here, and palaces on a large scale built for them, but since the well known mutiny of 1807, they have been removed to Bengal.

The great mass of the population profess the Hindoo religion, the Mahomedans being but thinly scattered through the country. It contains about 40,000 Christians of all descriptions. The whole population of the Carnatic, in its most extensive sense, may be estimated at five millions. The natives are considered inferior in bodily strength to the other natives of Hindostan Proper. In no part of India are the genuine Hindoo manners more purely preserved than among the majority of the natives of the Carnatic.

See Hamilton's *East India Gazetteer*, 8vo. London, 1815. Heyne's *Tracts, Historical and Statistical, on India*. 4to, London, 1814.

CARPENTRY.

It has been judged most expedient to reprint the article CARPENTRY from the *Supplement* to the third Edition of the *Encyclopædia*, in order that it

may form, with the articles ROOF and STRENGTH OF MATERIALS, * a uniform system of the most useful departments of practical mechanics, deduced, in

* It is proper to mention here, that these two articles, first printed in the *third*, were incorporated in the subsequent editions of the *Encyclopædia*, but that the connected article Carpentry, first published in the *Supplement* to that edition, was not; owing to this circumstance, that the copyright of the *Encyclopædia*, and of that Supplement, was for some time held by different Proprietors.—ED.

Carpentry. the same familiar and elementary manner, from the simple principles of the composition of forces: premising some Introductory Observations, which may be considered as a retrospective summary of the doctrine of Passive Strength, accompanied by some of the most useful propositions respecting the resistance of elastic substances, derived from the principles which have been already laid down in our article BRIDGE: and subjoining a few notes, on such passages as may appear to require further illustration or correction. Some of the demonstrations will be partly borrowed from a work which has been published since the death of Professor Robison, the able author of these three articles: but others will be more completely original: and of the remarks, the most important will probably be those which relate to the form and direction of the abutments of rafters; a subject which seems to have been very incorrectly treated by former writers on Carpentry.

I. ABSTRACT OF THE DOCTRINE OF PASSIVE STRENGTH.

The effects of forces of different kinds, on the materials employed in the mechanical arts, require to be minutely examined in the arrangement of every work dependent on them; and of these effects, as exhibited in a solid body at rest, we may distinguish seven different varieties: the extension of a substance acting simply as a tie; the compression of a block supporting a load above it; the detrusion of an axis resting on a support close to its wheel, and resisting by its lateral adhesion only; the flexure of a body bent by a force applied unequally to its different parts; the torsion or twisting, arising from a partial detrusion of the external parts in opposite directions, while the axis retains its place; the alteration or permanent change of a body which settles, so as to remain in a new form, when the force is withdrawn; and lastly, the fracture, which consists in a complete separation of parts before united, and which has been the only effect particularly examined by the generality of authors on the strength of materials.

The analogy of the laws of extension and compression has been demonstrated in a former article of this volume, and their connexion with flexure has been investigated: but it is not easy to compare them directly with the resistance opposed to a partial detrusion, the effects of which are only so far understood as they are exhibited in the phenomena of twisting: and these appear to justify us in considering the resistance of lateral adhesion as a primitive force, deduced from the rigidity or solidity of the substance, and proportional to the deviation from the natural situation of the particles. The resistance exhibited by steel wire, when twisted, bears a greater proportion to that of brass than the resistance to extension or compression; but the forces agree in being independent of the hardness produced by tempering.

Flexure may be occasioned either by a transverse or by a longitudinal force: when the force is transverse, the extent of the flexure is nearly proportion-

al to its magnitude; but when it is longitudinal, there is a certain magnitude which it must exceed, in order to produce or rather to continue the flexure, if the force be applied exactly at the axis. But it is equally true that the slightest possible force applied at a distance from the axis, however minute, or with an obliquity however small, or to a beam already a little curved, will produce a certain degree of flexure; and this observation will serve to explain some of the difficulties and irregularities which have occurred, in making experiments on beams exposed to longitudinal pressure.

Stiffness, or the power of resisting flexure, is measured by the force required to produce a given minute change of form. For beams similarly fixed, it is directly proportional to the breadth and the cube of the depth, and inversely to the cube of the length. Thus a beam or bar two yards long will be equally stiff with a beam one yard, provided that it be either twice as deep, or eight times as broad. If the ends of a beam can be firmly fixed, by continuing them to a sufficient distance, and keeping them down by a proper pressure, the stiffness will be four times as great as if the ends were simply supported. A hollow substance, of given weight and length, has its stiffness nearly proportional to the square of the diameter: and hence arises the great utility of tubes, when stiffness is required, this property being still more increased by the expansion of the substance than the ultimate strength. It is obvious that there are a multiplicity of cases in Carpentry where stiffness is of more importance than any other property, since the utility as well as beauty of the fabric might often be destroyed by too great a flexibility of the materials.

If we wish to find how much a beam of fir will sink when it is loaded in the middle, we may multiply the cube of the length in inches by the given weight in pounds, and divide by the cube of the depth, and by ten million times the breadth: but on account of the unequal texture of the wood, we must expect to find the bending somewhat greater than this in practice, besides that a large weight will often produce an alteration, or permanent settling, which will be added to it: a beam of oak will also sink a little more than a beam of fir, with the same weight.

With respect to torsion, the stiffness of a cylindrical body varies directly as the fourth power of the diameter, and inversely in the simple proportion of the length: it does not appear to be changed by the action of any force tending to lengthen or to compress the cylinder: and it may very possibly bear some simple relation to the force of cohesion, which has not yet been fully ascertained: but it appears that, in an experiment of Mr Cavepdish, the resistance of a cylinder of copper to a twisting force, acting at its surface, was about $\frac{1}{100}$ of the resistance that the same cylinder would have opposed to direct extension or compression.

Alteration is often an intermediate step between a temporary change and a complete fracture. There are many substances, which, after bending to a certain extent, are no longer capable of resuming their original form: and in such cases it generally hap-

Carpentry. pens that the alteration may be increased without limit, until complete fracture takes place, by the continued operation of the same force which has begun it, or by a force a little greater. Those substances which are the most capable of this change, are called ductile, and the most remarkable are gold, and a spider's web. When a substance has undergone an alteration by means of its ductility, its stiffness, in resisting small changes on either side, remains little or not at all altered. Thus if the stiffness of a spider's web, in resisting torsion, were sufficient at the commencement of an experiment, to cause it to recover itself, after being twisted in an angle of ten degrees, it would return ten degrees, and not more, after having been twisted round a thousand times. The ductility of all substances, capable of being annealed, is greatly modified by the effects of heat: hard steel, for example, is incomparably less subject to alteration than soft, although in some cases more liable to fracture; so that the degree of hardness requires to be proportioned to the uses for which each instrument is intended: although it was proved by Coulomb, and has since been confirmed by other observers, that the primitive stiffness of steel, in resisting small flexures, is neither increased nor diminished by any variation in its temper.

The strength of a body is measured by the force required completely to overcome the corpuscular powers concerned in the aggregation of its particles, and it is jointly proportional to the primitive stiffness, and to the toughness of the substance; that is, to the degree in which it is capable of a change of form without permanent alteration. It becomes however of importance in some cases, to consider the measure of another kind of strength, which has sometimes been called resilience, or the power of resisting a body in motion, and which is proportional to the strength and the toughness conjointly, that is, to the stiffness and the square of the toughness. Thus if we double the length of a given beam, we reduce its absolute strength to one half, and its stiffness to one eighth; but since the toughness, or the space, through which it will continue to resist, is quadrupled, the resilience will be doubled, and it would require a double weight to fall from the same height, or the same weight to fall from a double height, in order to overcome its whole resistance. If we wish to determine the resilience of a body from an experiment on its strength, we must measure the distance through which it recedes or is bent, previously to its fracture; and it may be shown that a weight, which is capable of breaking it by pressure, would also break it by impulse if it moved with the velocity acquired by falling from a height equal to half the deflection. Thus if a beam or bar were broken by a weight of 100 pounds, after being bent 6 inches, without alteration, it would also be broken by a weight of 100 pounds falling from a height of 3 inches, or moving in a horizontal direction with a velocity of 4 feet in a second, or by a weight of 1 pound falling from a height of 300 inches. This substitution of velocity for quantity of matter has however one limit, beyond which the velocity must prevail over the resistance, without regard to the quantity of matter, and this limit is

Carpentry. derived from the time required for the successive propagation of the pressure through the different parts of the substance, in order that they may participate in the resistance. Thus if a weight fell on the end of a bar or column with a velocity of 100 feet in a second, and the substance could only be compressed $\frac{1}{300}$ of its length, without being crushed, it is obvious that the pressure must be propagated through the substance, with a velocity of 20,000 feet in a second, in order that it might resist the stroke; and, in general, a substance will be crushed or penetrated by any velocity exceeding that which is acquired by a body falling from a height, which is to half that of the modulus of elasticity of the substance, as the square of the greatest possible change of length is to the whole length. From the consideration of the effect of rigidity in lessening the resilience of bodies, we may understand how a diamond, which is capable of resisting an enormous pressure, may be crushed with a blow of a small hammer, moving with a moderate velocity. It is remarkable that, for the same substance in different forms, the resilience is in most cases simply proportional to the bulk or weight, while almost every other kind of resistance is capable of infinite variation by change of form only.

The elaborate investigations of Mr Lagrange, respecting the strength and the strongest forms of columns, appear to have been conducted upon principles not altogether unexceptionable; but it is much easier to confute the results than to follow the steps of the computations. One great error is the supposition that columns are to be considered as elastic beams, bent by a longitudinal force; while, in reality, a stone column is never slender enough to be bent by a force which it can bear without being crushed: and even for such columns as are capable of being bent by a longitudinal force, Mr Lagrange's determinations are in several instances inadmissible; he asserts, for example, that a cylinder is the strongest of all possible forms, and that a cone is stronger than any conoid of the same bulk; but it appears to be demonstrable in a very simple manner, and upon incontestable principles, that a conoidal form may be determined, which shall be stronger than either a cone or a cylinder of the same bulk.

When a column is crushed, its resistance to compression seems to depend in great measure on the force of lateral adhesion, assisted by a kind of internal friction, dependent on the magnitude of the pressure, and it commonly gives way by the separation of a wedge in an oblique direction. If the adhesion were simply proportional to the section, it may be shown that a square column would be most easily crushed when the angle of the wedge is equal to half of a right angle; but, if the adhesion is increased by pressure, this angle will be diminished by half the angle of repose appropriate to the substance. In a wedge separated by a direct force from a prism of cast iron, the angle was found equal to $32\frac{1}{2}^{\circ}$, consequently the angle of repose was $2 \times 12\frac{1}{2}^{\circ} = 25^{\circ}$, and the internal friction to the pressure as 1 to .466, the tangent of this angle: there was, however, a little bubble in the course of

Carpentry. the fracture, which may have changed its direction in a slight degree. The magnitude of the lateral adhesion is measured by twice the height of the wedge, whatever its angle may be: in this instance the height was to the depth as 1.57 to 1, consequently the surface, affording an adhesion equal to the force, was somewhat more than three times as great as the transverse section, and the lateral adhesion of a square inch of cast iron would be equal to about 46,000 pounds: the direct cohesive force of the same iron was found by experiment equal to about 20,000 pounds for a square inch. It is obvious that experiments on the strength of a substance in resisting compression ought to be tried on pieces rather longer than cubes, since a cube would not allow of the free separation of a single wedge so acute as was observed in this experiment; although, indeed, the force required to separate a shorter wedge on each side would be little or no greater than for a single wedge. The same consideration of the oblique direction of the plane of easiest fracture would induce us to make the outline of a column a little convex externally, as the common practice has been: for a circle cut out of a plank possesses the advantage of resisting equally in every section, and consequently of exhibiting the strongest form, when there is no lateral adhesion; and in the case of an additional resistance proportional to the pressure, the strongest form is afforded by an oval consisting of two circular segments, each containing twice the angle formed by the plane of fracture with the horizon. If we wish to obtain a direct measure of the lateral adhesion, we must take care to apply the forces concerned at a distance from each other not greater than one sixth of the depth of the substance, otherwise the fracture will probably be rather the consequence of flexure than of detrusion. Professor Robison found this force in some instances twice as great as the direct cohesion, or nearly in the same proportion, as it appears to have been in the experiment on the strength of cast iron; Mr Coulomb thinks it most commonly equal only to the cohesion: and in fibrous substances, especially where the fibres are not perfectly straight, the repulsive strength is generally much less than would be inferred from this equality, and sometimes even less than the cohesive strength.

It is well known that the transverse strength of a beam is directly as the breadth, and as the square of the depth, and inversely as the length: and the variation of the results of some experiments from this law can only have depended on accidental circumstances. If we wish to find the number of hundred weights that will break a beam of oak, supported at both ends, supposing them to be placed exactly on the middle, we may multiply the square of the depth, in inches, by 100 times the breadth, and divide by the length; and we may venture in practice to load a beam with at least an eighth as much as this, or in case of necessity, even a fourth. And if the load be distributed equally throughout the length of the beam, it will support twice as much: but for a beam of fir, the strength is somewhat less than for oak. A cylinder will bear the same curvature as the circumscribing prism, and it may be shown that its strength, as well as its stiffness, is to that of the

prism as one fourth of its bulk is to one third of the bulk of the prism. The strength of a beam supported at its extremities may be doubled by firmly fixing the ends, where it is practicable; and we have already seen that the stiffness is quadrupled: but the resilience remains unaltered, since the resistance is doubled, and the space through which it acts is reduced to a half. It is therefore obviously of importance to consider the nature of the resistance that is required from the fabric which we are constructing. A floor, considered alone, requires to be strong; but in connexion with a ceiling, its stiffness requires more particular attention, in order that the ceiling may remain free from cracks. A coach spring requires resilience, for resisting the relative motions of the carriage, and we obtain this kind of strength as effectually by combining a number of separate plates, as if we united them into a single mass, while we avoid the stiffness, which would render the changes of motion inconveniently abrupt.

In all calculations respecting stiffness, it is necessary to be acquainted with the modulus of elasticity, which may be found, for a variety of substances, in the annexed table.

Height of the Modulus of Elasticity in Thousands of Feet.

Iron and steel,	10,000	Fir wood,	10,000
Copper,	5,700	Elm,	8,000
Brass,	5,000	Beech,	8,000
Silver,	3,240	Oak,	5,060
Tin,	2,250	Box,	5,050
Crown glass,	9,800	Ice,	850

II. PROPOSITIONS RELATING TO FLEXURE.

A. *The stiffness of a cylinder is to that of its circumscribing rectangular prism, as three times the bulk of the cylinder is to four times that of the prism.*

We may consider the different strata of the substance as acting on levers equal in length to the distance of each from the axis; for although there is no fixed fulcrum at the axis, yet the whole force is the same as if such a fulcrum existed, since the opposite actions of the opposite parts would relieve the fulcrum from all pressure. Then the tension of each stratum being also as the same distance x , and the breadth of the stratum being called $2y$, the fluxion of the force on either side of the axis will be $2x^2ydx$, while that of the force of the prism, the radius being r , is $2rx^2dx$. Now x being the area of half the portion included between the stratum and the axis, of

which the fluxion is ydx , the fluxion of $x = \frac{y^2x}{r}$ will

be $ydx = \frac{y^2dx}{r} = \frac{2y^2x dy}{r}$, or since $\frac{xx}{r} = 1 - \frac{yy}{r}$,

$\frac{xyydx}{r} = \frac{2y}{r} \frac{yx}{r} \left(-\frac{r dx}{y} \right)$, or $\frac{xyydx}{r} + \frac{3xyydx}{r} =$

$\frac{4xyydx}{r}$; consequently the fluent of $2x^2ydx$ is $\frac{1}{2}r^2x -$

$\frac{1}{2}y^2x$, which, when $y = 0$ becomes $\frac{1}{2}r^2x$, or one fourth of the product of the square of the radius by the area of the section, while the fluent of $2rx^2dx$,

Carpen-try. that is, $\frac{2}{3} r^2$, the force of the prism, becomes $\frac{2}{3} r^4$ or $\frac{1}{3} r^2 \times 2r^2$, one third of the product of the same square into the area of the section of the prism.

Hence the radius of curvature of a cylindrical column, instead of $\frac{Maa}{12fy}$ (ART. BRIDGE, Prop. G), will

be $\frac{Maa}{16fy}$, the weight of the modulus M decreasing in

the same proportion as the bulk, when the prism is reduced to a cylinder. The force is supposed in this proposition to be either transverse or applied at a considerable distance from the axis: but the error will not be material in any other case.

B. When a longitudinal force f is applied to the extremities of a straight prismatic beam, at the distance b from the axis, the deflection of the middle of the

beam will be $b \left(\text{SECANT} \left[\sqrt{\left(\frac{3f}{M}\right) \cdot \frac{c}{a}} \right] - 1 \right)$; M

being the weight of the modulus, c the length of the beam, and a its depth.

The curvature being proportional to the distance from the line of direction of the force, or to the ordinate, when that line is considered as the absciss, the elastic curve must, in this case, initially coincide with a portion of the harmonic curve, well known for its utility in the resolution of a variety of problems of this kind. Now if the half length of the complete curve be called k, corresponding to a quadrant of the generating circle, and the greatest ordinate y, c being the quadrant of a circle of which the radius is unity, the radius of curvature r corresponding to y will be

$\frac{kk}{ccy}$, that is, a third proportional to y and $\frac{k}{c}$ the ra-

dius of the generating circle; consequently $\frac{Maa}{12fy} =$

$\frac{kk}{ccy}$, $kk = \frac{Maacc}{12f}$, and $k = \frac{1}{2} \sqrt{\frac{M}{3f}} \cdot ac$; but, by the

nature of the curve, $y : b = 1 : c \frac{ec}{2k} = \text{SEC.} \frac{ec}{2k} : 1$ and

$y = b \text{ SEC.} \frac{ec}{2k} = b \text{ SEC.} \sqrt{\frac{3f}{M}} \cdot \frac{c}{a}$, which is the ordi-

nate at the middle; and the deflection from the natural situation is $y - b$.

It follows that, since the secant of the quadrant is infinite, when $\sqrt{\frac{3f}{M}} \cdot \frac{c}{a}$ becomes equal to c, the de-

flection will be infinite, and the resistance of the column will be overcome, however small the distance b may be taken, provided that it be of finite magni-

tude; and since in this case $\frac{3fec}{Maa} = cc$, $f = \frac{Maacc}{3ec} =$

$.8225 M \frac{aa}{ec}$, which is the utmost force that the col-

umn will bear: and for a cylinder we find, by the

same reasoning, $f = \frac{Maacc}{4ec} = .6169 M \frac{aa}{ec}$. If b be

supposed to vanish, we shall have in theory an equi-

librium without flexure, but since it will be totter- Carpen-try, ing, it cannot exist in nature.

By applying this determination to the strength of wood and iron, compared with the modulus of elasticity, it appears, that a round column or a square pillar of either of these substances cannot be bent by any longitudinal force applied to the axis, which it can withstand without being crushed, unless its length be greater than 12 or 13 times its thickness, respectively: nor a column or pillar of stone, unless, it be 40 or 45 times as long as it is thick. Hence we may infer, as a practical rule, that every piece of timber or iron, intended to withstand any considerable compressing force, should be at least as many inches in thickness as it is feet in length, in order to avoid the loss of force which necessarily arises from curvature.

C. When a beam, fixed at one end, is pressed by a force in a direction deviating from the original position of the axis in a small angle, of which the tangent

is t, the deflection becomes $d = at \sqrt{\frac{M}{12f}}$ TANG.

$\left(\sqrt{\frac{12f}{M}} \cdot \frac{c}{a} \right)$.

The inclination of the curve to the absciss being inconsiderable, it will not differ sensibly from a portion of a harmonic curve; and supposing the quadrantal length of this curve k, we have again, as in

the last proposition, $k = \frac{1}{2} \sqrt{\frac{M}{3f}} \cdot ac$, or, for a cylin-

der, $k = \frac{1}{2} \sqrt{\frac{M}{f}} \cdot ac$. Now, the tangent of the in-

clination of the harmonic curve varies as the sine of the angular distance from the middle, consequently

as $\left(\frac{k-c}{k} \right) \cdot c$, or $\frac{ec}{k}$ is to the radius, so is the tan-

gent t, expressing the difference of inclination of the end of the beam and the direction of the force, which is also that of the middle of the supposed curve, to the tangent of the extreme inclination of the curve to its absciss, which will therefore

be $t \text{ SEC.} \frac{ec}{k}$: consequently the greatest ordinate will

be $\frac{kt}{c} \text{ SEC.} \frac{ec}{k}$, and since the ordinates are as the

sines of the angular distances from the origin of the curve, the ordinate at the fixed end of the beam,

corresponding to the angle $\frac{ec}{k}$, that is, the deflection,

will be $\frac{kt}{c} \text{ SEC.} \frac{ec}{k} \cdot \frac{ec}{k} = \frac{kt}{c} \text{ TANG.} \frac{ec}{k} = \frac{1}{2} \sqrt{\frac{M}{3f}} \cdot at$

$\text{TANG.} \frac{2e}{a} \sqrt{\frac{3f}{M}}$, or, for a cylinder, $\frac{1}{2} \sqrt{\frac{M}{f}} \cdot at \text{ TANG.}$

$\frac{4e}{a} \sqrt{\frac{f}{M}}$.

By means of this proposition we may determine

Carpentry. the effect of a small lateral force in weakening a beam or pillar, which is at the same time compressed longitudinally by a much greater force; considering the parts on each side of the point, to which the lateral force is applied, as portions of two beams, bent in the manner here described, by a single force slightly inclined to the axis.

D. A bar fixed at one end, and bent by a transverse force applied to the other end, assumes initially the form of a cubic parabola, and the deflection at the end is $d = \frac{4e^3f}{Maa}$.

The ordinate of a cubic parabola varying as x^3 , its second fluxion varies as $6x(dx)^2$, or since the first fluxion of the absciss is constant, simply as the absciss x , measured from the vertex of the parabola, which must therefore be situated at the end to which the force is applied, and the absciss must coincide with the tangent of the bar. But if we begin from the other end, we must substitute $e-x$ for x , and the second fluxion of the ordinate will be as $6(e-x)(dx)^2$, the first as $6exdx-3x^2dx$, and the fluent as $3ex^2-x^3$, which, when $x=e$, becomes $2e^3$, while it would have been $3e^3$ if the curvature had been uniform, and the second fluxion had been every where $6e(dx)^2$. Now the radius of curvature at the fixed end being $r = \frac{Maa}{12ef}$, and the versed sine of a small

portion of a circle being equal to $\frac{ee}{2r}$, this versed sine will be expressed by $\frac{6e^3f}{Maa}$; and two thirds of this, or $\frac{4e^3f}{Maa}$, will be the actual deflection.

E. The depression of a bar, fixed horizontally at one end, and supporting only its own weight, is $d = \frac{3e^4}{2maa}$; m being the height of the modulus of elasticity.

The curvature here varies as the square of the distance from the end, because the strain is proportional to the weight of the portion of the bar beyond any given point, and to the distance of its centre of gravity conjointly, that is, to $(e-x) \frac{1}{2}(e-x)$, so that if the second fluxion at the fixed end be as $e^2(dx)^2$, it will elsewhere be as $(e-x)^2(dx)^2$; and the corresponding first fluxions being e^2xdx and $e^2xdx - ex^2dx + \frac{1}{2}x^2dx$, the fluents will be $\frac{1}{2}e^2x^2$, and $\frac{1}{2}e^2x^2 - \frac{1}{2}ex^3 + \frac{1}{6}x^3$, or, when $x=e$, $\frac{1}{2}e^3$, and $(\frac{1}{2} - \frac{1}{2} + \frac{1}{6})e^3 = \frac{1}{6}e^3$; consequently the depression must be half the versed sine in the circle of greatest

curvature. Now the radius of curvature $\frac{Maa}{12fy}$ becomes here $\frac{Maa}{6ef}$, the force being applied at the distance $\frac{1}{2}e$: and since the weight of the bar is to that of the modulus of elasticity in the proportion of the respective lengths, we have $\frac{f}{M} = \frac{e}{m}$, and $r = \frac{maa}{6ee}$, and

the versed sine for the ordinate e will be $\frac{3e^4}{maa}$, half of which is the actual depression.

F. The depression of the middle of a horizontal bar, fixed at both ends, and supporting its own weight only, is $d = \frac{5e^4}{32maa}$.

The transverse force at each point of such a bar, resisted by the lateral adhesion, is as the distance x from the middle (Art. BRIDGE, under Prop. L.); but this force is proportional to the first fluxion of the strain or curvature, consequently the curvature itself must vary as the corrected fluent of $\pm xdx$, taking here the negative sign, because the curvature diminishes as x increases; and the corrected fluent will be $\frac{1}{2}e^2-x^2$, since it must vanish when $x = \frac{1}{2}e$; the first fluxion of the ordinate will then be $\frac{1}{2}e^2dx - \frac{1}{2}x^2dx$, and the fluent $\frac{1}{2}e^2x^2 - \frac{1}{6}x^3$, or for the whole length $\frac{1}{2}e$, $\frac{1}{16}e^4$, instead of $\frac{1}{32}e^4$, or $\frac{1}{16}e^4$, which would have been its value if the curvature had been equal throughout. Now the strain at the middle is the difference of the opposite strains, produced by the forces acting on either side; and these are the half weight, acting at the mean distance $\frac{1}{2}e$, and the resistance of the support, which is equal to the same half weight, but acts at the distance $\frac{1}{2}e$, the difference being equivalent to the half weight, acting at the distance $\frac{1}{2}e$, so that the curvature at the middle is the same as if the bar were fixed there, and loose at the ends, that is, as in the last proposition, substituting $\frac{1}{2}e$ for e , $r = \frac{2maa}{3ee}$; and the versed sine at

the distance $\frac{1}{2}e$ being $\frac{e^2}{8r}$, or $\frac{3e^4}{16maa}$, $\frac{1}{2}$ of this will be

$\frac{5e^4}{32maa}$. This demonstration may serve as an illustration of two modes of considering the effect of a strain, which have not been generally known, and which are capable of a very extensive application.

It follows that where a bar is equally loaded throughout its length, the curvature at the middle is half as great as if the whole weight were collected there, the strain derived from the resistance of the support remaining in that case uncompensated. The depression produced by the divided weight will be $\frac{1}{2}$ as great as by the single weight, since $\frac{1}{2} \times \frac{1}{2}$ is to $\frac{1}{4}$ as 5 to 8. Mr Dupin found the proposition by many experiments, between $\frac{2}{3}$ and $\frac{3}{4}$; and $\frac{2}{3}$ is a very good mean for representing these results.

III. ELEMENTS OF CARPENTRY.

“Carpentry is the art of framing timber for the purposes of Architecture, Machinery, and, in general, for all considerable structures.

It is not intended in this article to give a full account of Carpentry as a mechanical art, or to describe the various ways of executing its different works, suited to the variety of materials employed, the processes which must be followed for fashioning and framing them for our purposes, and the tools

carpentry. which must be used, and the manner in which they must be handled : This would be an occupation for volumes ; and though of great importance, must be entirely omitted here. Our only aim at present will be to deduce, from the principles and laws of mechanics, and the knowledge which experience and judicious inferences from it have given us concerning the strength of timber, in relation to the strain laid on it, such maxims of construction as will unite economy with strength and efficacy.

This object is to be attained by a knowledge, 1st, of the strength of our materials, and of the absolute strain that is to be laid on them ; 2dly, of the modifications of this strain, by the place and direction in which it is exerted, and the changes that can be made by a proper disposition of the parts of our structure ; and, 3dly, having disposed every piece in such a manner as to derive the utmost advantage from its relative strength, we must know how to form the joints and other connections in such a manner as to secure the advantages derived from this disposition.

This is, evidently, a branch of mechanical science which makes Carpentry a liberal art, constitutes part of the learning of the ENGINEER, and distinguishes him from the workman. Its importance in all times and states of civil society is manifest and great. In the present condition of these kingdoms, raised, by the active ingenuity and energy of our countrymen, to a pitch of prosperity and influence unequalled in the history of the world, a condition which consists chiefly in the superiority of our manufactures, attained by prodigious multiplication of engines of every description, and for every species of labour, the SCIENCE (so to term it) of Carpentry is of immense consequence. We regret therefore exceedingly, that none of our celebrated artists have done honour to themselves and their country, by digesting into a body of consecutive doctrines the results of their experience, so as to form a system from which their pupils might derive the first principles of their education. The many volumes called COMPLETE INSTRUCTORS, MANUALS, &c. take a much humbler flight, and content themselves with instructing the mere workman, or sometimes give the master builder a few approved forms of roofs and other framings, with the rules for drawing them on paper ; and from thence forming the working draughts which must guide the saw and the chisel of the workman. Hardly any of them offer any thing that can be called a principle, applicable to many particular cases, with the rules for this adaptation. We are indebted for the greatest part of our knowledge of this subject to the labours of literary men, chiefly foreigners, who have published in the memoirs of the learned academies dissertations on different parts of what may be termed the Science of Carpentry. It is singular, that the members of the Royal Society of London, and even of that established and supported by the patriotism of these days for the Encouragement of the Arts, have contributed so little to the public instruction in this respect. We observe of late some beginnings of this kind, such as the last part of Nicholson's *Carpenter's and Joiner's Assistant*, published by J. Taylor, Holborn, 1797. And it is with

an important Branch of Mechanical Science.

principally indebted to foreigners for a Knowledge of this subject.

pleasure that we can say, that we were told by the editor, that this work was prompted in a great measure by what has been delivered in the *Encyclopædia Britannica* in the articles ROOF and STRENGTH OF MATERIALS. It abounds more in important and new observations than any book of the kind that we are acquainted with. We again call on such as have given a scientific attention to this subject, and pray that they would render a meritorious service to their country by imparting the result of their researches. The very limited nature of this work does not allow us to treat the subject in detail ; and we must confine our observations to the fundamental and leading propositions.

The theory (so to term it) of Carpentry is founded on two distinct portions of mechanical sciences, namely, a knowledge of the strains to which framings of timber are exposed, and a knowledge of their relative strength.

We shall therefore attempt to bring into one point of view the propositions of mechanical science that are more immediately applicable to the art of Carpentry, and are to be found in various articles of our work, particularly ROOF and STRENGTH OF MATERIALS. From these propositions we hope to deduce such principles as shall enable an attentive reader to comprehend distinctly what is to be aimed at in framing timber, and how to attain this object with certainty ; and we shall illustrate and confirm our principles by examples of pieces of Carpentry which are acknowledged to be excellent in their kind.

The most important proposition of general mechanics to the carpenter is that which exhibits the composition and resolution of forces ; and we beg our practical readers to endeavour to form very distinct conceptions of it, and to make it very familiar to their mind. When accommodated to their chief purposes, it may be thus expressed :

1. If a body, or any part of a body, be at once pressed in the two directions AB. AC (fig. 1. Plate XLVIII.), and if the intensity or force of those pressures be in the proportion of these two lines, the body is affected in the same manner as if it were pressed by a single force acting in the direction AD, which is the diagonal of the parallelogram ABDC formed by the two lines, and whose intensity has the same proportion to the intensity of each of the other two that AD has to AB or AC.

Such of our readers as have studied the laws of motion, know that this is fully demonstrated. Such as wish for a very accurate view of this proposition, will do well to read the demonstration given by D. Bernoulli, in the first volume of the *Comment. Petropol.*, and the improvement of this demonstration by D'Alembert in his *Opuscules* and in the *Comment. Taurinens.* The practitioner in Carpentry will get more useful confidence in the doctrine, if he will shut his book, and verify the theoretical demonstrations by actual experiments. They are remarkably easy and convincing. Therefore it is our request that the artist, who is not so habitually acquainted with the subject, do not proceed further till he has made it quite familiar to his thoughts. Nothing is so conducive to this

Carpentry.

Theory founded on what.

Composition and Resolution of Forces.

Illustrated by Experiment.

Carpentry as the actual experiment; and since this only requires the trifling expence of two small pulleys and a few yards of whipcord, we hope that none of our practical readers will omit it: They will thank us for this injunction.

2. Let the threads Ad , AFb , and AEc (fig. 2.), have the weights d , b , and c , appended to them, and let two of the threads be laid over the pulleys F and E . By this apparatus the knot A will be drawn in the directions AB , AC , and AK . If the sum of the weights b and c be greater than the single weight d , the assemblage will of itself settle in a certain determined form: if you pull the knot A out of its place, it will always return to it again, and will rest in no other position. For example, if the three weights are equal, the threads will always make equal angles, of 120 degrees each, round the knot. If one of the weights be three pounds, another four, and the third five, the angle opposite to the thread stretched by five pounds will always be square, &c. When the knot A is thus in equilibrio, we must infer, that the action of the weight d , in the direction Ad , is in direct opposition to the combined action of b in the direction AB , and of c , in the direction AC . Therefore, if we produce dA to any point D , and take AD to represent the magnitude of the force, or pressure exerted by the weight d , the pressures exerted on A by the weights b and c , in the directions AB , AC , are in fact equivalent to a pressure acting in the direction AD ; whose intensity we have represented by AD . If we now measure off by a scale on AF and AE , the lines AB and AC , having the same proportions to AD that the weights b and c have to the weight d , and if we draw DB and DC , we shall find BC to be equal and parallel to AB , and DB equal and parallel to AC ; so that AD is the diagonal of a parallelogram $ABDC$. We shall find this always to be the case, whatever are the weights made use of; only we must take care that the weight which we cause to act without the intervention of a pulley be less than the sum of the other two: if any one of the weights exceeds the sum of the other two, it will prevail, and drag them along with it.

Now since we know that the weight d would just balance an equal weight g , pulling directly upwards by the intervention of the pulley G ; and since we see that it just balances the weights b and c , acting in the directions AB , AC , we must infer, that the knot A is affected in the same manner by those two weights or by the single weight g ; and therefore that two pressures, acting in the directions, and with the intensities, AB , AC , are equivalent to a single pressure having the direction and proportion of AD . In like manner, the pressures AB , AK , are equivalent to AH , which is equal and opposite to AC . Also AK and AC are equivalent to AI , which is equal and opposite to AB .

We shall consider this combination of pressures a little more particularly.

Suppose an upright beam BA (fig. 3.) pushed in the direction of its length by a load B , and abutting on the ends of two beams AC , AD , which are firmly resisted at their extreme points C and D , which rest on two blocks, but are nowise joined to them: these two beams can resist no way but in the direc-

tions CA , DA ; and therefore the pressures which they sustain from the beam BA are in the directions AC , AD . We wish to know how much each sustains? Produce BA to E , taking AE from a scale of equal parts, to represent the number of tons or pounds by which BA is pressed. Draw EF and EG parallel to AD and AC ; then AF , measured on the same scale, will give us the number of pounds by which AC is strained or crushed, and AG will give the strain on AD .

It deserves particular remark here, that the length of AC or AD has no influence on the strain, arising from the thrust of BA , while the directions remain the same. The effects, however, of this strain are modified by the length of the piece on which it is exerted. This strain compresses the beam, and will therefore compress a beam of double length twice as much. This may change the form of the assemblage. If AC , for example, be very much shorter than AD , it will be much less compressed: the line CA will turn about the centre C , while DA will hardly change its position; and the angle CAD will grow more open, the point A sinking down. The artist will find it of great consequence to pay a very minute attention to this circumstance, and to be able to see clearly the change of shape which necessarily results from these mutual strains. He will see in this the cause of failure in many very great works.—By thus changing shape, strains are often produced in places where there were none before, and frequently of the very worst kind, tending to break the beams across.

The dotted lines of this figure show another position of the beam AD' . This makes a prodigious change; not only in the strain on AD' , but also in that on AC . Both of them are much increased; AG is almost doubled, and AF is four times greater than before. This addition was made to the figure, to show what enormous strains may be produced by a very moderate force AE , when it is exerted on a very obtuse angle.

The 4th and 5th figures will assist the most unconstructed reader in conceiving how the very same strains AF , AG , are laid on these beams, by a weight simply hanging from a billet resting on A , pressing hard on AD , and also leaning a little on AC ; or by an upright piece AE , joggled on the two beams AC , AD , and performing the office of an ordinary king-post. The reader will thus learn to call off his attention from the means by which the strains are produced, and learn to consider them abstractedly merely as strains, in whatever situation he finds them, and from whatever cause they arise.

We presume that every reader will perceive, that the proportions of these strains will be precisely the same if every thing be inverted, and each beam be drawn or pulled in the opposite direction. In the same way that we have substituted a rope and weight in fig. 4. or a king-post in fig. 5. for the loaded beam BA of fig. 3. we might have substituted the framing of fig. 6. which is a very usual practice. In this framing, the batten DA is stretched by a force AG , and the piece AC is compressed by a force AF . It is evident, that we may employ a rope, or an iron rod hooked on at D , in place

Carpentry. Of the batten DA, and the strains will be the same as before.

This seemingly simple matter is still full of instruction; and we hope that the well-informed reader will pardon us, though we dwell a little longer on it for the sake of the young artist.

By changing the form of this framing, as in fig. 7. we produce the same strains as in the disposition represented by the dotted lines in fig. 3. The strains on both the battens AD, AC, are now greatly increased.

The same consequences result from an improper change of the position of AC. If it is placed as in fig. 8. the strains on both are vastly increased. In short, the rule is general; that the more open we make the angle against which the push is exerted, the greater are the strains which are brought on the struts or ties which form the sides of the angle.

The reader may not readily conceive the piece AC of fig. 8. as sustaining a compression; for the weight B appears to hang from AC as much as from AD. But his doubts will be removed by considering whether he could employ a rope in place of AC. He cannot; but AD may be exchanged for a rope. AC is therefore a strut, and not a tie.

In fig. 9. Plate XLIX. AD is again a strut, butting on the block D, and AC is a tie; and the batten AC may be replaced by a rope. While AD is compressed by the force AG, AC is stretched by the force AF.

If we give AC the position represented by the dotted lines, the compression of AD is now AG', and the force stretching AC' is now AF'; both much greater than they were before.* This disposition is analogous to fig. 8. and to the dotted lines in fig. 3. Nor will the young artist have any doubts of AC' being on the stretch, if he consider whether AD can be replaced by a rope. It cannot, but AC' may; and it is therefore not compressed, but stretched.

In fig. 10. all the three pieces, AC, AD, and AB, are ties, on the stretch. This is the complete inversion of fig. 3.; and the dotted position of AC induces the same changes in the forces AF, AG', as in fig. 3.

Thus have we gone over all the varieties which can happen in the bearings of three pieces on one point. All calculations about the strength of carpentry are reduced to this case: for when more ties or braces meet in a point (a thing that rarely happens), we reduce them to three, by substituting for any two the force which results from their combination, and then combining this with another; and so on.

The young artist must be particularly careful not to mistake the kind of strain that is exerted on any

piece of the framing, and suppose a piece to be a *Carpentry* brace which is really a tie. It is very easy to avoid all mistakes in this matter by the following rule, which has no exception. (See Note AA.)

Take notice of the direction in which the piece acts from which the strain proceeds. Draw a line in that direction from the point on which the strain is exerted; and let its length (measured on some scale of equal parts) express the magnitude of this action in pounds, hundreds, or tons. From its remote extremity draw lines parallel to the pieces on which the strain is exerted. The line parallel to one piece will necessarily cut the other, or its direction produced: if it cut the piece itself, that piece is compressed by the strain, and it is performing the office of a strut or brace; if it cut its direction produced, the piece is stretched, and it is a tie. In short, the strains on the pieces AC, AD, are to be estimated in the direction of the points F and G from the strained point A. Thus, in fig. 3. the upright piece BA, loaded with the weight B, presses the point A in the direction AE; so does the rope AB in the other figures, or the batten AB in fig. 5.

In general, if the straining piece is within the angle formed by the pieces which are strained, the strains which they sustain are of the opposite kind to that which it exerts. If it be pushing, they are drawing; but if it be within the angle formed by their directions produced, the strains which they sustain are of the same kind. All the three are either drawing or pressing. If the straining piece lie within the angle formed by one piece and the produced direction of the other, its own strain, whether compression or extension, is of the same kind with that of the most remote of the other two, and opposite to that of the nearest. Thus, in fig. 9. where AB is drawing, the remote piece AC is also drawing, while AD is pushing or resisting compression.

In all that has been said on this subject, we have not spoken of any joints. In the calculations with which we are occupied at present, the resistance of joints has no share; and we must not suppose that they exert any force which tends to prevent the angles from changing. The joints are supposed perfectly flexible, or to be like compass joints; the pin of which only keeps the pieces together when one or more of the pieces draws or pulls. The carpenter must always suppose them all compass joints when he calculates the thrusts and draughts of the different pieces of his frames. The strains on joints, and their power to produce or balance them, are of a different kind, and require a very different examination.

Seeing that the angles which the pieces make with each other are of such importance to the mag-
General ex-
pression of the mag-
nitude of
the strain.

* The reader is requested to add accents to the lower C, the upper F, and the lower G, in this figure. In fig. 10. for b, read C', and add accents to the upper F and the lower G. In fig. 12. the dotted line should be continued upwards, and marked L. In fig. 16. the letters should stand thus, C E e D f F B. The arrangements required, for delivering every plate with the text to which it belongs, have made it necessary to work off these engravings before the order of their occurrence, a circumstance with which the author of the remarks on this article was not acquainted, in time to have them corrected.

Carpentry. nitude and the proportion of the excited strains, it is proper to find out some way of readily and compendiously conceiving and expressing this analogy.

In general, the strain on any piece is proportional to the straining force. This is evident.

Secondly, the strain on any piece AC is proportional to the sine of the angle which the straining force makes with the other piece directly, and to the sine of the angle which the pieces make with each other inversely.

For it is plain, that the three pressures AE, AF, and AG, which are exerted at the point A, are in the proportion of the lines AE, AF, and FE (because FE is equal to AG). But because the sides of a triangle are proportional to the sines of the opposite angles, the strains are proportional to the sines of the angles AFE, AEF, and FAE. But the sine of AFE is the same with the sine of the angle CAD, which the two pieces AC and AD make with each other; and the sine of AEF is the same with the sine of EAD, which the straining piece BA makes with the piece AC. Therefore we have this analogy, $\text{Sin. CAD} : \text{Sin. EAD} =$

$$\text{AE} : \text{AF}, \text{ and } \text{AF} = \text{AE} \times \frac{\text{Sin. EAD}}{\text{Sin. CAD}} \text{— Now the}$$

sines of angles are most conveniently conceived as decimal fractions of the radius, which is considered as unity. Thus, $\text{Sin. } 30^\circ$ is the same thing with 0.5, or $\frac{1}{2}$; and so of others. Therefore, to have the strain on AC, arising from any load AE acting in the direction AE, multiply AE by the sine of EAD, and divide the product by the sine of CAD.

This rule shows how great the strains must be when the angle CAD becomes very open, approaching to 180 degrees. But when the angle CAD becomes very small, its sine, (which is our divisor) is also very small; and we should expect a very great quotient in this case also. But we must observe, that in this case the sine of EAD is also very small; and this is our multiplier. In such a case, the quotient cannot exceed unity.

But it is unnecessary to consider the calculation by the tables of sines more particularly. The angles are seldom known any otherwise but by drawing the figure of the frame of carpentry. In this case, we can always obtain the measures of the strains from the same scale, with equal accuracy, by drawing the parallelogram AFCG.

Strains propagated to the points of support.

Hitherto we have considered the strains excited at A only as they affect the pieces on which they are exerted. But the pieces, in order to sustain, or be subject to, any strain, must be supported at their ends C and D; and we may consider them as mere intermediums, by which these strains are made to act on those points of support: Therefore AF and AG are also measures of the forces which press or pull at C and D. Thus we learn the supports which must be found for these points. These may be infinitely various. We shall attend only to such as somehow depend on the framing itself.

Action of a Straining Beam.

Such a structure as fig. 11. very frequently occurs, where a beam BA is strongly pressed to the end of another beam AD, which is prevented from yielding, both because it lies on another beam HD,

and because its end D is hindered from sliding backwards. It is indifferent from what this pressure arises: we have represented it as owing to a weight hung on at B, while B is withheld from yielding by a rod or rope hooked to the wall. The beam AD may be supposed at full liberty to exert all its pressure on D, as if it were supported on rollers lodged in the beam HD; but the loaded beam BA presses both on the beam AD and on HD. We wish only to know what strain is borne by AD?

All bodies act on each other in the direction perpendicular to their touching surfaces; therefore the support given by HD is in a direction perpendicular to it. We may therefore supply its place at A by a beam AC, perpendicular to HD, and firmly supported at C. In this case, therefore, we may take AE, as before, to represent the pressure exerted by the loaded beam, and draw EG perpendicular to AD, and EF parallel to it, meeting the perpendicular AC in F. Then AG is the strain compressing AD, and AF is the pressure on the beam HD.

It may be thought, that since we assume as a principle that the mutual pressures of solid bodies are exerted perpendicular to their touching surfaces, this balance of pressures, in framings of timbers, depends on the directions of their butting joints: but it does not, as will readily appear by considering the present case. Let the joint or abutment of the two pieces BA, AD be mitred, in the usual manner, in the direction $fA f'$. Therefore, if Ae be drawn perpendicular to Af , it will be the direction of the actual pressure exerted by the loaded beam BA on the beam AD. But the reaction of AD, in the opposite direction At , will not balance the pressure of BA; because it is not in the direction precisely opposite. BA will therefore slide along the joint, and press on the beam HD. AE represents the load on the mitre joint A. Draw Ee perpendicular to Ae , and Ef parallel to it. The pressure AE will be balanced by the reactions eA and fA : or, the pressure AE produces the pressures Ae and Af ; of which Af must be resisted by the beam HD, and Ae by the beam AD. The pressure Af not being perpendicular to HD, cannot be fully resisted by it; because (by our assumed principle) it reacts only in a direction perpendicular to its surface. Therefore draw fp, fi parallel to HD, and perpendicular to it. The pressure Af will be resisted by HD with the force pA ; but there is required another force iA , to prevent the beam BA from slipping outwards. This must be furnished by the reaction of the beam DA. (See Note BB.) In like manner, the other force Ae cannot be fully resisted by the beam AD, or rather by the prop D, acting by the intervention of the beam; for the action of that prop is exerted through the beam in the direction DA. The beam AD, therefore, is pressed to the beam HD by the force Ae , as well as by Af . To find what this pressure on HD is, draw eg perpendicular to HD, and eo parallel to it, cutting EG in r . The forces gA and oA will resist, and balance Ae .

Thus we see, that the two forces Ae and Af , which are equivalent to AE, are equivalent also to Ap, Ai ,

Carpentry. *Ao*, and *Ag*. But because *Af* and *eE* are equal and parallel, and *Er* and *fi* are also parallel, as also *er* and *fp*, it is evident, that *if* is equal to *rE*, or to *oF*, and *iA* is equal to *re*, or to *Gg*. Therefore the four forces *Ag*, *Ao*, *Ap*, *Ai*, are equal to *AG* and *AF*. Therefore *AG* is the compression of the beam *AD*, or the force pressing it on *D*, and *AF* is the force pressing it on the beam *HD*. The proportion of these pressures, therefore, is not affected by the form of the joint.

This remark is important; for many carpenters think the form and direction of the butting joint of great importance; and even the theorist, by not prosecuting the general principle through *all* its consequences, may be led into an error. The form of the joint is of no importance, in as far as it affects the strains in the direction of the beams; but it is often of great consequence, in respect to its own firmness, and the effect it may have in bruising the piece on which it acts, or being crippled by it.

origin of the Strain in a Tie-beam.

The same compression of *AB*, and the same thrust on the point *D* by the intervention of *AD*, will obtain, in whatever way the original pressure on the end *A* is produced. Thus, supposing that a cord is made fast at *A*, and pulled in the direction *AE*, and with the same force, the beam *AD* will be equally compressed, and the prop *D* must react with the same force.

But it often happens that the obliquity of the pressure on *AD*, instead of compressing it, stretches it; and we desire to know what tension it sustains. Of this we have a familiar example in a common roof. Let the two rafters *AC*, *AD* (fig. 12.), press on the tie-beam *DC*. We may suppose the whole weight to press vertically on the ridge *A*, as if a weight *B* were hung on there. (See Note CC.) We may represent this weight by the portion *Ab* of the vertical or plumb line, intercepted between the ridge and the beam. Then drawing *bf* and *bg* parallel to *AD* and *AC*, *Ag* and *Af* will represent the pressures on *AC* and *AD*. Produce *AC* till *CH* be equal to *Af*. The point *C* is forced out in this direction, and with a force represented by this line. As this force is not perpendicularly across the beam, it evidently stretches it; and this extending force must be withstood by an equal force pulling it in the opposite direction. This must arise from a similar oblique thrust of the opposite rafter on the other end *D*. We concern ourselves only with this extension at present; but we see that the cohesion of the beam does nothing but supply the balance to the extending forces. It must still be supported externally, that it may resist, and by resisting obliquely, be stretched. The points *C* and *D* are supported on the walls, which they press in the directions *CK* and *DO*, parallel to *Ab*. If we draw *HK* parallel to *DC*, and *HI* parallel to *CK* (that is to *Ab*), meeting *DC* produced in *I*, it follows from the composition of forces, that the point *C* would be supported by the two forces *KC* and *IC*. In like manner, making *DN* = *Ag*, and completing the parallelogram *DMNO*, the point *D* would be supported by the forces *OD* and *MD*. If we draw *go* and *fk* parallel to *DC*, it is plain that they are equal to *NO* and *CI*, while *Ao* and *Ak* are equal to

Carpentry. *DO* and *CK*, and *Ab* is equal to the sum of *DO* and *CK* (because it is equal to *Ao* + *Ak*). The weight of the roof is equal to its vertical pressure on the walls.

Thus we see, that while a pressure on *A*, in the direction *Ab*, produces the strains *Af* and *Ag*, on the pieces *AC* and *AD*, it also excites a strain *CI* or *DM* in the piece *DC*. And this completes the mechanism of a frame; for all derive their efficacy from the triangles of which they are composed, as will appear more clearly as we proceed.

But there is more to be learned from this. The External consideration of the strains on the two pieces *AD* and *AC*, by the action of a force at *A*, only showed them as the means of propagating the same strains in their own direction to the points of support. But, by adding the strains exerted in *DC*, we see that the frame becomes an intermedium, by which exertions may be made on other bodies, in certain directions and proportions; so that this frame may become part of a more complicated one, and, as it were, an element of its constitution. It is worth while to ascertain the proportion of the pressures *CK* and *DO*, which are thus exerted on the walls. The similarity of triangles gives the following analogies:

$$\begin{aligned} DO : DM &= Ab : bD \\ CI, \text{ or } DM : CK &= Cb : Ab \\ \text{Therefore } DO : CK &= Cb : bD. \end{aligned}$$

Or, the pressures on the points *C* and *D*, in the direction of the straining force *Ab*, are reciprocally proportional to the portions of *DC* intercepted by *Ab*.

Also, since *Ab* is = *DO* + *CK*, we have
 $Ab : CK = Cb + bD \text{ (or } CD) : bD, \text{ and}$
 $Ab : DO = CD : bC.$

In general, any two of the three parallel forces *Ab*, *DO*, *CK*, are to each other in the reciprocal proportion of the parts of *CD*, intercepted between their directions and the direction of the third.

And this explains a still more important office of the frame *ADC*. If one of the points, such as *D*, be supported, an external power acting at *A*, in the direction *Ab*, and with an intensity which may be measured by *Ab*, may be set in equilibrio, with another acting at *C*, in the direction *CL*, opposite to *CK* or *Ab*, and with an intensity represented by *CK*: for since the pressure *CH* is partly withstood by the force *IC*, or the firmness of the beam *DC* supported at *D*, the force *KC* will complete the balance. When we do not attend to the support at *D*, we conceive the force *Ab* to be balanced by *KC*, or *KC* to be balanced by *Ab*. And, in like manner, we may neglect the support or force acting at *A*, and consider the force *DO* as balanced by *CK*.

Thus our frame becomes a lever, and we are able to trace the interior mechanical procedure which gives it its efficacy: it is by the intervention of the forces of cohesion, which connect the points to which the external forces are applied with the supported point or fulcrum, and with each other.

These strains or pressures *Ab*, *DO*, and *CK*, not being in the directions of the beams, may be called *transverse*. We see that by their means a frame of

Carpentry. carpentry may be considered as a solid body: but the example which brought this to our view is too limited for explaining the efficacy which may be given to such constructions. We shall therefore give a general proposition, which will more distinctly explain the procedure of nature, and enable us to trace the strains as they are propagated through all the parts of the most complicated framing, finally producing the exertion of its most distant points.

General Proposition.

We presume that the reader is now pretty well habituated to the conception of the strains as they are propagated along the lines joining the points of a frame, and we shall therefore employ a very simple figure.

Let the strong lines ACBD (fig. 13.) represent a frame of carpentry. Suppose that it is pulled at the point A by a force acting in the direction AE, but that it rests on a fixed point C, and that the other extreme point B is held back by a power which resists in the direction BF: It is required to determine the proportion of the strains excited in its different parts, the proportion of the external pressures at A and B; and the pressure which is produced on the obstacle or fulcrum C?

It is evident that each of the external forces at A and B tend one way, or to one side of the frame, and that each would cause it to turn round C if the other did not prevent it; and that if, notwithstanding their action, it is turned neither way, the forces in actual exertion are in equilibrio by the intervention of the frame. It is no less evident that these forces concur in pressing the frame on the prop C. Therefore, if the piece CD were away, and if the joints C and D be perfectly flexible, the pieces CA, CB would be turned round the prop C, and the pieces AD, DB would also turn with them, and the whole frame change its form. This shows, by the way, and we desire it to be carefully kept in mind, that the firmness or stiffness of framing depends entirely on the triangles bounded by beams which are contained in it. An open quadrilateral may always change its shape, the sides revolving round the angles. A quadrilateral may have an infinity of forms, without any change of its sides, by merely pushing two opposite angles towards each other, or drawing them asunder. But when the three sides of a triangle are determined, its shape is also invariably determined; and if two angles be held fast, the third cannot be moved. It is thus that, by inserting the bar CD, the figure becomes unchangeable; and any attempt to change it by applying a force to an angle A, immediately excites forces of attraction or repulsion between the particles of the stuff which form its sides. Thus it happens, in the present instance, that a change of shape is prevented by the bar CD. The power at A presses its end against the prop; and in doing this it puts the bar AD on the stretch; and also the bar DB. Their places might therefore be supplied by cords or metal wires. Hence it is evident that DC is compressed, as is also AC; and, for the same reason, CB is also in a state of compression; for either A or B may be considered as the point that is impelled or withheld. Therefore DA and DB are stretched, and are resisting with attractive forces. DC and CB are compressed, and are resisting with

repulsive forces: and thus the support of the prop, combined with the firmness of DC, puts the frame ADBC into the condition of the two frames in fig. 8. and fig. 9. Therefore the external force at A is really in equilibrio with an attracting force acting in the direction AD, and a repulsive force acting in the direction AK. And since all the connecting forces are mutual and equal, the point D is pulled or drawn in the direction DA. The condition of the point B is similar to that of A, and D is also drawn in the direction DB. Thus the point D, being urged by the forces in the directions DA and DB, resists the beam DC on the prop, and the prop resists in the opposite direction. Therefore the line DC is the diagonal of the parallelogram, whose sides have the proportion of the forces which connect D with A and B. This is the principle on which the rest of our investigation proceeds. We may take DC as the representation and measure of their joint effect. Therefore draw CH, CG, parallel to DA, DB. Draw HL, GO, parallel to CA, CB, cutting AE, BF, in L and O, and cutting DA, DB in I and M. Complete the parallelograms ILKA, MONB. Then DG and AI are the equal and opposite forces which connect A and D; for $GD = CH = AI$. In like manner DH and BM are the forces which connect D and B.

The external force at A is in immediate equilibrio with the combined forces, connecting A with D and with C. AI is one of them: Therefore AK is the other; and AL is the compound force with which the external force at A is in immediate equilibrium. This external force is therefore equal and opposite to AL. In like manner, the external force at B is equal and opposite to BO; and AL is to BO as the external force at A to the external force at B. The prop C resists with forces equal to those which are propagated to it from the points D, A, and B. Therefore it resists with forces CH, CG; equal and opposite to DG, DH; and it resists the compressions KA, NB, with equal and opposite forces CL, CN. Draw W, no parallel to AD, BD; and draw CQ, CoP: It is plain that $ACHW$ is a parallelogram equal to KAIL, and that CW is equal to AL. In like manner Co is equal to BO. Now the forces CL, CH, exerted by the prop, compose the force C; and CN, CG compose the force Co. These two forces C, Co are equal and parallel to AL and BO; and therefore they are equal and opposite to the external forces acting at A and B. But they are (primitively) equal and opposite to the pressures (or at least the compounds of the pressures) exerted on the prop, by the forces propagated to C from A, D, and B. Therefore the pressures exerted on the prop are the same as if the external forces were applied there in the same directions, as they are applied to A and B. Now if we make Co, Cn equal to Cl and Cc, and complete the parallelogram CVYZ; it is plain that the force YC is in equilibrio with IC and cC. Therefore the pressures at A, C, and B, are such as would balance if applied to one point.

Lastly, in order to determine their proportions, draw CS and CN perpendicular to DA and DB. Also draw Ad, Bf perpendicular to CQ and CP; and draw Cg, Ci perpendicular to AE, BF.

Carpentry. The triangles CPR and BPf are similar, having a common angle P, and a right angle at R and f.

In like manner the triangles CQS and AQd are similar. Also the triangles CHR, CGS are similar, by reason of the equal angles at H and G, and the right angles at R and S. Hence we obtain the following analogies :

$$\begin{aligned} Co : CP &= on : PB, = CG : PB \\ CP : CR &= PB : fB \\ CR : CS &= CH : CG \\ CS : CQ &= Ad : AQ \\ CQ : Cl &= AQ : h, = AQ : CH \end{aligned}$$

Therefore, by equality,

$$\begin{aligned} Co : Cl &= Ad : fB \\ \text{or } BO : AL &= Cg : Ci. \end{aligned}$$

That is, the external forces are reciprocally proportional to the perpendiculars drawn from the prop on the lines of their direction.*

extensive
consequences.

This proposition (sufficiently general for our purpose) is fertile in consequences, and furnishes many useful instructions to the artist. The strains LA, OB, CY, that are excited, occur in many, we may say in all, framings of carpentry, whether for edifices or engines, and are the sources of their efficacy. It is also evident, that the doctrine of the transverse strength of timber is contained in this proposition; for every piece of timber may be considered as an assemblage of parts, connected by forces which act in the direction of the lines which joined the strained points on the matter which lies between those points, and also act on the rest of the matter, exciting those lateral forces which produce the inflexibility of the whole. See STRENGTH OF MATERIALS, *Encyclopædia*.

Thus it appears that this proposition contains the principles which direct the artist to frame the most powerful levers; to secure uprights by shores or braces, or by tiers and ropes; to secure scaffoldings for the erection of spires, and many other more delicate problems of his art. He also learns from this proposition, how to ascertain the strains that are produced, without his intention, by pieces which he in-

tended for other offices, and which, by their transverse action, put his work in hazard. In short, this proposition is the key to the science of this art.

We would now counsel the artist, after he has made the tracing of the strains and thrusts through the various parts of a frame familiar to his mind, and even amused himself with some complicated fancy framings, to read over with care the articles STRENGTH OF MATERIALS and ROOF in the *Encyclopædia*. He will now conceive its doctrines much more clearly than when he was considering them as abstract theories. The mutual action of the woody fibres will now be easily comprehended, and his confidence in the results will be greatly increased.

There is a proposition (No. 19. article Roof in the *Decision of Encyclopædia*), which has been called in question by a Disputed and very Important Question.

several very intelligent persons; and they say that Belidor has demonstrated, in his *Science des Ingenieurs*, that a beam firmly fixed at both ends is not twice as strong as when simply lying on the props; and that its strength is increased only in the proportion of two to three; and they support this determination by a list of experiments recited by Belidor, which agree precisely with it. Belidor also says, that Pitot had the same result in his experiments. These are respectable authorities: but Belidor's reasoning is any thing but demonstration; and his experiments are described in such an imperfect manner, that we cannot build much on them. It is not said in what manner the battens were secured at the ends, any farther than that it was by *chevalets*. If by this word is meant a tressle, we cannot conceive how they were employed; but we see it sometimes used for a wedge or key. If the battens were wedged in the holes, their resistance to fracture may be made what we please; they may be made loose, and therefore resist little more than when simply laid on props. They may be (and probably were) wedged very fast, and bruised or crippled.

Our proposition mentioned distinctly the security given to the ends of the beams. They were mortised into remote posts. Our precise meaning was, that they were simply kept from rising by these mortises, but at full liberty to bend up at E and I, and between G and K. Our assertion was not made

* "The learned reader will perceive, that this analogy is precisely the same with that of forces which are in equilibrio by the intervention of a lever. In fact, this whole frame of carpentry is nothing else than a built or framed lever in equilibrio. It is acting in the same manner as a solid, which occupies the whole figure compressed in the frame, or as a body of any size and shape whatever that will admit the three points of application A, C, and B. It is always in equilibrio in the case first stated; because the pressure produced at B by a force applied to A is always such as balances it. The reader may also perceive, in this proposition, the analysis or tracing of those internal mechanical forces which are indispensably requisite for the functions of a lever. The mechanicians have been extremely puzzled to find a legitimate demonstration of the equilibrium of a lever ever since the days of Archimedes. Mr Vince has the honour of first demonstrating, most ingeniously, the principle assumed by Archimedes, but without sufficient ground, for his demonstration: but Mr Vince's demonstration is only a putting the mind into that perplexed state which makes it acknowledge the proposition, but without a clear perception of its truth. The difficulty has proceeded from the abstract notion of a lever, conceiving it as a mathematical line—inflexible, without reflecting how it is inflexible,—for the very source of this indispensable quality furnishes the mechanical connection between the remote pressures and the fulcrum; and this supplies the demonstration (without the least difficulty) of the desperate case of a straight lever urged by parallel forces. See ROTATION in the *Encyclopædia*."

Carpentry. from theory alone (although we think the reasoning incontrovertible), but was agreeable to numerous experiments made in those precise circumstances. Had we mortised the beams firmly into two very stout posts, which could not be drawn nearer to each other by bending, the beam would have borne a *much* greater weight, as we have verified by experiments. We hope that the following mode of conceiving this case will remove all doubts.

Let LM be a long beam (fig. 14.) divided into six equal parts, in the points D, B, A, C, E. Let it be firmly supported at L, B, C, M. Let it be cut through at A, and have compass joints at B and C. Let FB, GC be two equal uprights, resting on B and C, but without any connection. Let AH be a similar and equal piece, to be occasionally applied at the seam A. Now let a thread or wire AGE be extended over the piece GC, and made fast at A, G, and E. Let the same thing be done on the other side of A. If a weight be now laid on at A, the wires AFD, AGE will be strained and may be broken. In the instant of fracture we may suppose their strains to be represented by Af and Ag . Complete the parallelogram, and Aa is the magnitude of the weight. It is plain that nothing is concerned here but the cohesion of the wires; for the beam is sawed through at A, and its parts are perfectly moveable round B and C.

Instead of this process apply the piece AH below A, and keep it there by straining the same wire BHC over it. Now lay on a weight. It must press down the ends of BA and CA, and cause the piece AH to strain the wire BHC. In the instant of fracture of the same wire, its resistances Hb and Hc must be equal to Af and Ag , and the weight hH which breaks them must be equal to Aa .

Lastly, employ all the three pieces FB, AH, GC, with the same wire attached as before. There can be no doubt but that the weight which breaks all the four wires must be $= aA + hH$, or twice Aa .

The reader cannot but see that the wires perform the very same office with the fibres of an entire beam LM held fast in the four holes D, B, C, and E, of some upright posts.

In the experiments for verifying this, by breaking slender bars of fine deal, we get complete demonstration, by measuring the curvatures produced in the parts of the beam thus held down, and comparing them with the curvature of a beam simply laid on the props B and C: and there are many curious inferences to be made from these observations, but we have not room for them in this place.

We may observe by the way, that we learn from this case, that purlins are able to carry twice the load when notched into the rafters that they carry when mortised into them, which is the most usual manner of framing them. So would the bending joists of floors; but this would double the thickness of the flooring. But this method should be followed in every possible case, such as breast summers, lintels over several pillars, &c. These should never be cut off and mortised into the sides of every upright: numberless cases will occur which show the importance of the maxim.

We must here remark, that the proportion of

the spaces BC and CM, or BC and LB, has a very sensible effect on the strength of the beam BC; but we have not yet satisfied our minds as to the *rationale* of this effect. It is undoubtedly connected with the serpentine form of the curve of the beam before fracture. This should be attended to in the construction of the springs of carriages. These are frequently supported at a middle point (and it is an excellent practice), and there is a certain proportion which will give the easiest motion to the body of the carriage. We also think that it is connected with that deviation from the best theory observable in Buffon's experiments on various lengths of the same scantling. The force of the beams diminished much more than in the inverse proportion of their lengths.

We have seen that it depends entirely on the position of the pieces in respect of their points of ultimate support, and of the direction of the external force which produces the strains, whether any particular piece is in a state of extension or of compression. The knowledge of this circumstance may greatly influence us in the choice of the construction. In many cases we may substitute slender iron rods for massive beams, when the piece is to act the part of a tie. But we must not invert this disposition; for when a piece of timber acts as a strut, and is in a state of compression, it is next to certain that it is not equally compressible in its opposite sides through the whole length of the piece, and that the compressing force on the abutting joint is not acting in the most equable manner all over the joint. A very trifling inequality in either of these circumstances (especially in the first) will compress the beam more on one side than on the other. This cannot be without the beam's bending, and becoming concave on that side on which it is most compressed. When this happens, the frame is in danger of being crushed, and soon going to ruin. It is, therefore, indispensably necessary to make use of beams in all cases where struts are required of considerable length, rather than of metal rods of slender dimensions, unless in situations where we can effectually prevent their bending, as in trussing a girder internally, where a cast iron strut may be firmly cased in it, so as not to bend in the smallest degree. In cases where the pressures are enormous, as in the very oblique struts of a centre or arch frame, we must be particularly cautious to do nothing which can facilitate the compression of either side. No mortises should be cut near to one side; no lateral pressures, even the slightest, should be allowed to touch it. We have seen a pillar of fir 12 inches long, and one inch in section, when loaded with three tons, snap in an instant when pressed on one side by 16 pounds, while another bore $4\frac{1}{2}$ tons without hurt, because it was inclosed (loosely) in a stout pipe of iron. (See Note DD.)

In such cases of enormous compression, it is of great importance that the compressing force bear equally on the whole abutting surface. The German carpenters are accustomed to put a plate of lead over the joint. This prevents, in some measure, the penetration of the end fibres. Mr Perronet, the celebrated French architect, formed his abutments into arches of circles, the centre of which was the re-

Carpentry.

In what cases Ties are better than Struts.

Carpentry.

Genl Theo connect the re Struts Beam

The best manner of Framing Portico.

Carpentry. mote end of the strut. By this contrivance the unavoidable change of form of the triangle made no partial bearing of either angle of the abutment. This always has a tendency to splinter off the heel of the beam where it presses strongest. It is a very judicious practice. (See Note EE.)

When circumstances allow it, we must rather employ ties than struts for securing a beam against lateral strains. When an upright pillar, such as a flag-staff, a mast, or the uprights of a very tall scaffolding, are to be shored up, the dependence is more certain on those braces that are stretched by the strain than on those which are compressed. The scaffolding of the iron bridge near Sunderland had some ties very judiciously disposed, and others with less judgment.

We should proceed to consider the transverse strains as they affect the various parts of a frame of carpentry; but we have very little to add to what has been said already in the article STRENGTH OF MATERIALS (*Encycl.*), and in the article ROOF. What we shall add in this article will find a place in our occasional remarks on different works. It may, however, be of use to recal to the reader's memory the following propositions.

General Theorems concerning the relative Strength of Beams.

1. When a beam AB (fig. 15.) is firmly fixed at the end A, and a straining force acts perpendicularly to its length at any point B, the strain occasioned at any section C between B and A is proportional to CB, and may therefore be represented by the product $W \times CB$; that is, by the product of the number of tons, pounds, &c. which measure the straining force, and the number of feet, inches, &c. contained in CB. As the loads on a beam are easily conceived, we shall substitute this for any other straining force.

2. If the strain or load is uniformly distributed along any part of the beam lying beyond C (that is, further from A), the strain at C is the same as if the load were all collected at the middle point of that part; for that point is the centre of gravity of the load.

3. The strain on any section D of a beam AB (fig. 16.) resting freely on two props A and B, is $w \times \frac{AD \times DB}{AB}$. (See ROOF, No. 19. and STRENGTH OF MATERIALS, No. 92., &c. *Encyclopædia.*) Therefore,

4. The strain on the middle point, by a force applied there, is one-fourth of the strain which the same force would produce, if applied to one end of a beam of the same length, having the other end fixed.

5. The strain on any section C of a beam, resting on two props A and B, occasioned by a force applied perpendicularly to another point D, is proportional to the rectangle of the exterior segments, or is equal to $w \times \frac{AC \times DB}{AB}$. Therefore,

The strain at C occasioned by the pressure on D, is the same with the strain at D occasioned by the same pressure on C.

6. The strain on any section D, occasioned by a

load uniformly diffused over any part EF, is the same as if the two parts ED, DF of the load were collected at their middle points *e* and *f*. Therefore, The strain on any part D, occasioned by a load uniformly distributed over the whole beam, is one half of the strain that is produced when the same load is laid on at D; and

The strain on the middle point C, occasioned by a load uniformly distributed over the whole beam, is the same which half that load would produce if laid on at C.

7. A beam supported at both ends on two props B and C (fig. 14.) will carry twice as much when the ends beyond the props are kept from rising, as it will carry when it rests loosely on the props.

8. Lastly, the transverse strain on any section, occasioned by a force applied obliquely, is diminished in the proportion of the sine of the angle which the direction of the force makes with the beam. Thus, if it be inclined to it in an angle of thirty degrees, the strain is one half of the strain occasioned by the same force acting perpendicularly.

On the other hand, the RELATIVE STRENGTH of a beam, or its power in any particular section to resist any transverse strain, is proportional to the absolute cohesion to the section directly, to the distance of its centre of effort from the axis of fracture directly, and to the distance from the strained point inversely.

Thus in a rectangular section of the beam, of which *b* is the breadth, *d* the depth (that is, the dimension in the direction of the straining force), measured in inches, and *f* the number of pounds which one square inch will just support without being torn asunder, we must have $f \times b \times d^2$, proportional to $w \times CB$ (fig. 15.) Or, $f \times b \times d^2$, multiplied by some number *m*, depending on the nature of the timber, must be equal to $w \times CB$. Or, in the case of the section C of fig. 16. that is strained by the force *w* applied at D, we must have $m \times fbd^2 =$

$w \times \frac{AC \times DB}{AB}$. Thus if the beam is of sound oak,

m is very nearly = $\frac{1}{9}$ (see STRENGTH OF MATERIALS, No. 116, *Encycl.*) Therefore we have $\frac{fbd^2}{9} = w$

$\times \frac{AC \times CB}{AB}$. (See Note FF.)

Hence we can tell the precise force *w* which any section C can just resist when that force is applied in any way whatever. For the above-mentioned formula gives $w = \frac{fbd^2}{9CB}$, for the case represented by

fig. 15. But the case represented in fig. 16. having the straining force applied at D, gives the strain at

$C (= w) = f \times \frac{bd^2 \times AB}{9AC \times CB}$.

Example. Let an oak beam, four inches square, rest freely on the props A and B, seven feet apart, or 84 inches. What weight will it just support at

Carpentry. its middle point C, on the supposition that a square inch rod will just carry 16,000 pounds, pulling it asunder?

$$\text{The formula becomes } w = \frac{16000 \times 4 \times 16 \times 84}{9 \times 42 \times 42}$$

or $w = \frac{86016000}{15876} = 5418$ pounds. This is very near what was employed in Buffon's experiment, which was 5312.

Had the straining force acted on a point D, half way between C and B, the force sufficient to break

$$\text{the beam at C would be } = \frac{16000 \times 4 \times 16 \times 84}{9 \times 42 \times 21} =$$

10836 lbs.

Had the beam been sound red fir, we must have taken $f = 10,000$ nearly, and m nearly 8; for although fir be less cohesive than oak in the proportion of 5 to 8 nearly, it is less compressible, and its axis of fracture is therefore nearer to the concave side.

Of Joints.

HAVING considered at sufficient length the strains of different kinds which arise from the form of the parts of a frame of carpentry, and the direction of the external forces which act on it, whether considered as impelling or as supporting its different parts, we must now proceed to consider the means by which this form is to be secured, and the connections by which those strains are excited and communicated.

The joinings practised in carpentry are almost infinitely various, and each has advantages which make it preferable in some circumstances. Many varieties are employed merely to please the eye. We do not concern ourselves with these: Nor shall we consider those which are only employed in connecting small works, and can never appear on a great scale; yet even in some of these, the skill of the carpenter may be discovered by his choice; for in all cases, it is wise to make every, even the smallest, part of his work as strong as the materials will admit. He will be particularly attentive to the changes which will necessarily happen by the shrinking of timber as it dries, and will consider what dimensions of his framings will be affected by this, and what will not; and will then dispose the pieces which are less essential to the strength of the whole, in such a manner that their tendency to shrink shall be in the same direction with the shrinking of the whole framing. If he do otherwise, the seams will widen, and parts will be split asunder. He will dispose his boardings in such a manner as to contribute to the stiffness of the whole, avoiding at the same time the giving them positions which will produce lateral strains on truss beams which bear great pressures; recollecting, that although a single board has little force, yet many united have a great deal, and may frequently perform the office of very powerful struts.

Our limits confine us to the joinings which are most essential for connecting the parts of a single piece of a frame when it cannot be formed of one beam, either for want of the necessary thickness or length; and the joints for connecting the different sides of a trussed frame.

Much ingenuity and contrivance has been be-

stowed on the manner of building up a great beam of many thicknesses, and many singular methods are practised as great nostrums by different artists: but when we consider the manner in which the cohesion of the fibres performs its office, we will clearly see that the simplest are equally effected with the most refined, and that they are less apt to lead us into false notions of the strength of the assemblage.

Thus, were it required to build up a beam for a great lever or a girder, so that it may act nearly as a beam of the same size of one log—it may either be done by plain joggling, as in Plate L. fig. 17. A, or by scarfing, as in fig. 17. B or C. If it is to act as a lever, having the gudgeon on the lower side at C, we believe that most artists will prefer the form B and C; at least this has been the case with nine-tenths of those to whom we have proposed the question. The best informed only hesitated; but the ordinary artists were all confident in its superiority; and we found their views of the matter very coincident. They considered the upper piece as grasping the lower in its hooks; and several imagined that, by driving the one very tight on the other, the beam would be stronger than an entire log; but if we attend carefully to the internal procedure in the loaded lever, we shall find the upper one clearly the strongest. If they are formed of equal logs, the upper one is thicker than the other by the depth of the joggling or scarfing, which we suppose to be the same in both; consequently, if the cohesion of the fibres in the intervals is able to bring the uppermost filaments into full action, the form A is stronger than B, in the proportion of the greater distance of the upper filaments from the axis of the fracture: this may be greater than the difference of the thickness, if the wood is very compressible. If the gudgeon be in the middle, the effect, both of the joggles and the scarfings, is considerably diminished; and if it is on the upper side, the scarfings act in a very different way. In this situation, if the loads on the arms are also applied to the upper side, the joggled beam is still more superior to the scarfed one. This will be best understood by resolving it in imagination into a trussed frame. But when a gudgeon is thus put on that side of the lever which grows convex by the strain, it is usual to connect it with the rest by a powerful strap, which embraces the beam, and causes the opposite point to become the resisting point. This greatly changes the internal actions of the filaments, and, in some measure, brings it into the same state as the first, with the gudgeon below. Were it possible to have the gudgeon on the upper side, and to bring the whole into action without a strap, it would be the strongest of all; because, in general, the resistance to compression is greater than to extension. In every situation the joggled beam has the advantage; and it is the easiest executed. (See Note GG.)

We may frequently gain a considerable accession of strength by this building up of a beam; especially if the part which is stretched by the strain be of oak, and the other part be fir. Fir being so much superior to oak as a pillar (if Muschenbroek's experiments may be confided in), and oak so much preferable as a tie, this construction seems to unite both

Carpentry. advantages. But we shall see much better methods of making powerful levers, girders, &c. by trussing.

Observe, that the efficacy of both methods depends entirely on the difficulty of causing the piece between the cross-joints to slide along the timber to which it adheres. Therefore, if this be moderate, it is wrong to make the notches deep; for as soon as they are so deep that their ends have a force sufficient to push the slice along the line of junction, nothing is gained by making them deeper; and this requires a greater expenditure of timber.

Scarings are frequently made oblique, as in fig. 18.; but we imagine that this is a bad practice. It begins to yield at a point, where the wood is crippled, and splintered off, or at least bruised out a little: as the pressure increases, this part, by squeezing broader, causes the solid parts to rise a little upwards, and gives them some tendency, not only to push their antagonists along the base, but even to tear them up a little. For similar reasons, we disapprove of the favourite practice of many artists, to make the angles of their scarings acute, as in fig. 19. This often causes the two pieces to tear each other up. The abutments should always be perpendicular to the directions of the pressures. Lest it should be forgotten in its proper place, we may extend this injunction also to the abutments of different pieces of a frame, and recommend it to the artist even to attend to the shrinking of the timbers by drying. When two timbers abut obliquely, the joint should be most full at the obtuse angle of the end; because, by drying, that angle grows more obtuse, and the beam would then be in danger of splintering off at the acute angle.

We must not wedge too hard.

It is evident, that the nicest work is indispensably necessary in building up a beam. The parts must abut on each other completely, and the smallest play or void takes away the whole efficacy. It is usual to give the butting joints a small taper to one side of the beam, so that they may require moderate blows of a maul to force them in, and the joints may be perfectly close when the external surfaces are even on each side of the beam. But we must not exceed in the least degree; for a very taper wedge has great force; and if we have driven the pieces together by very heavy blows, we leave the whole in a state of violent strain, and the abutments are perhaps ready to splinter off by a small addition of pressure. This is like too severe a proof for artillery: which, though not sufficient to burst the pieces, has weakened them to such a degree, that the strain of ordinary service is sufficient to complete the fracture. The workman is tempted to exceed in this, because it smooths off and conceals all uneven seams; but he must be watched. It is not unusual to leave some abutments open enough to admit a thin wedge reaching through the beam. Nor is this a bad practice, if the wedge is of materials which is not compressed by the driving or the strain of service. Iron would be preferable for this purpose, and for the joggles, were it not that by its too great hardness it cripples the fibres of timber to some distance. In consequence of this, it often happens that, in beams which are subjected to desultory and sudden strains (as in the

levers of reciprocating engines), the joggles or wedges widen the holes, and work themselves loose: Therefore skilful engineers never admit them; and indeed as few bolts as possible, for the same reason: but when resisting a steady or dead pull, they are not so improper, and are frequently used.

Beams are built up, not only to increase their dimensions in the direction of the strain (which we have hitherto called their depth), but also to increase their breadth, or the dimensions perpendicular to the strain. We sometimes double the breadth of a girder which is thought too weak for its load, and where we must not increase the thickness of the flooring.

The mast of a great ship of war must be made bigger athwartship, as well as fore and aft. This is one of the nicest problems of the art; and professional men are by no means agreed in their opinions about it. We do not presume to decide; and shall content ourselves with exhibiting the different methods.

Building of Masts.

The most obvious and natural method is that shown in fig. 20. It is plain that (independent of the connection of cross bolts, which are used in them all when the beams are square) the piece C cannot bend in the direction of the plane of the figure without bending the piece D along with it. This method is much used in the French navy: but it is undoubtedly imperfect. Hardly any two great trees are of equal quality, and swell or shrink alike. If C shrinks more than D, the feather of C becomes loose in the groove wrought in D to receive it; and when the beam bends, the parts can slide on each other like the plates of a coach spring; and if the bending is in the direction *ef*, there is nothing to hinder this sliding but the bolts, which soon work themselves loose in the bolt-holes.

Method used in the French Navy.

Fig. 21. exhibits another method. The two halves of the beam are tabled into each other in the same manner as in fig. 17. It is plain that this will not be affected by the unequal swelling or shrinking, because this is insensible in the direction of the fibres; but when bent in the direction *ab*, the beam is weaker than fig. 20. bent in the direction *ef*. Each half of fig. 20. has, in every part of its length, a thickness greater than half the thickness of the beam. It is the contrary in the alternate portions of the halves of fig. 21. When one of them is bent in the direction AB, it is plain that it drags the other with it by means of the cross butments of its tables, and there can be no longitudinal sliding. But unless the work is accurately executed, and each hollow completely filled up by the table of the other piece, there will be a lateral slide along the cross joints sufficient to compensate for the curvature; and this will hinder the one from compressing or stretching the other in conformity to this curvature.

Another Method.

The imperfection of this method is so obvious, that it has seldom been practised: but it has been combined with the other, as is represented in fig. 22. where the beams are divided along the middle, and the tables in each half are alternate, and alternate also with the tables of the other half. Thus 1, 3, 4, are prominent, and 5, 2, 6, are depressed. This construction evidently puts a stop to both slides, and obliges every part of both pieces to move together. *ab* and *cd* show

Its imperfection.

Carpentry. sections of the built-up beam corresponding to AB and CD.

No more is intended in this practice by any intelligent artist, than the causing the two pieces to act together in all their parts, although the strains may be unequally distributed on them. Thus, in a built-up girder, the binding joists are frequently mortised into very different parts of the two sides. But many seem to aim at making the beam stronger than if it were of one piece; and this inconsiderate project has given rise to many whimsical modes of tabling and scarfing, which we need not regard.

British method.

The practice in the British dock-yards is somewhat different from any of these methods. The pieces are tabled as in fig. 22. but the tables are not thin parallelepipeds, but thin prisms. The two outward joints or visible seams are straight lines, and the table No. 1. rises gradually to its greatest thickness in the axis. In like manner, the hollow 5 for receiving the opposite table, sinks gradually from the edge to its greatest depth in the axis. Fig. 23. No. 1. represents a section of a round piece of timber built up in this way, where the full line EFGH is the section corresponding to AB of fig. 22., and the dotted line EGFH is the section corresponding to CD.

This construction, by making the external seam straight, leaves no lodgment for water, and looks much fairer to the eye; but it appears to us that it does not give such firm hold when the mast is bent in the direction EH. The exterior parts are most stretched and most compressed by this bending; but there is hardly any abutment in the exterior parts of these tables. In the very axis, where the abutment is the firmest, there is little or no difference of extension and compression.

But this construction has an advantage, which we imagine much more than compensates for these imperfections, at least in the particular case of a round mast: it will draw together by hooping incomparably better than any of the others. If the cavity be made somewhat too shallow for the prominence of the tables, and if this be done uniformly along the whole length, it will make a somewhat open seam: and this opening can be regulated with the utmost exactness from end to end by the plane. The heart of those vast trunks is very sensibly softer than the exterior circles: Therefore, when the whole is hooped, and the hoops hard driven, and at considerable intervals between each spell—we are confident that all may be compressed till the seam disappears; and then the whole makes one piece, much stronger than if it were an original log of that size, because the middle has become, by compression, as solid as the crust, which was naturally firmer, and resisted farther compression. We verified this beyond a doubt, by hooping a built stick of a timber which has this inequality of firmness in a remarkable degree, and it was nearly twice as strong as another of the same size.

Our mastmakers are not without their fancies and whims; and the manner in which our masts and yards are generally built up, is not near so simple as fig. 23.: but it consists of the same essential parts, acting in the very same manner, and derives all

its efficacy from the principles which are here employed. Carpentry

This construction is particularly suited to the situation and office of a ship's mast. It has no bolts; or, at least, none of any magnitude, or that make very important parts of its construction. The most violent strains perhaps that it is exposed to, is that of twisting, when the lower yards are close braced up by the force of many men acting by a long lever. This form resists a twist with peculiar energy: it is therefore an excellent method for building up a great shaft for a mill. The way in which they are usually built up is by reducing a central log to a polygonal prism, and then filling it up to the intended size by *planting* pieces of timber along its sides, either spiking them down, or cocking them into it by a feather, or joggling them by slips of hard wood sunk into the central log and into the slips. *N.B.* Joggles of elm are sometimes used in the middle of the large tables of masts; and when sunk into the firm wood near the surface, they must contribute much to the strength. But it is very necessary to employ wood not much harder than the pine; otherwise it will soon enlarge its bed, and become loose; for the timber of these large trunks is very soft.

Attended with peculiar advantages.

The most general reason for piercing a beam is to increase its length. This is frequently necessary, in order to procure tie-beams for very wide roofs. Two pieces must be scarfed together.—Numberless are the modes of doing this; and almost every master carpenter has his favourite nostrum. Some of them are very ingenious: But here, as in other cases, the most simple are commonly the strongest. We do not imagine that any, the most ingenious, is equally strong with a tie consisting of two pieces of the same scantling laid over each other for a certain length, and firmly bolted together. We acknowledge that this will appear an artless and clumsy tie-beam; but we only say that it will be stronger than any that is more artificially made up of the same thickness of timber. This, we imagine, will appear sufficiently certain.

Various methods of scarfing.

The simplest and most obvious scarfing (after the one now mentioned) is that represented in fig. 24., No. 1. and 2. If considered merely as two pieces of wood joined, it is plain that, as a tie, it has but half the strength of an entire piece, supposing that the bolts (which are the only connections) are fast in their holes. No. 2. requires a bolt in the middle of the scarf to give it that strength; and, in every other part, is weaker on one side or the other. (See Note HH.)

But the bolts are very apt to bend by the violent strain, and require to be strengthened by uniting their ends by iron plates; in which case it is no longer a wooden tie. The form of No. 1. is better adapted to the office of a pillar than No. 2.; especially if its ends be formed in the manner shown in the elevation No. 3. By the sally given to the ends, the scarf resists an effort to bend it in that direction. Besides, the form of No. 2. is unsuitable for a post; because the pieces, by sliding on each other by the pressure, are apt to splinter off the tongue which confines their extremity.

Carpentry.

Fig. 25. and 26. exhibit the most approved form of a scarf, whether for a tie or for a post. The key represented in the middle is not essentially necessary; the two pieces might simply meet square there. This form, without a key, needs no bolts (although they strengthen it greatly); but, if worked very true and close, and with square abutments, will hold together, and will resist bending in any direction. But the key is an ingenious and a very great improvement, and will force the parts together with perfect tightness. The same precaution must be observed that we mentioned on another occasion, not to produce a constant internal strain on the parts by overdriving the key. The form of fig. 25. is by far the best; because the triangle of 26 is much easier splintered off by the strain, or by the key, than the square wood of 25. It is far preferable for a post, for the reason given when speaking of fig. 24., No. 1. and No. 2. Both may be formed with a sally at the ends equal to the breadth of the key. In this shape fig. 25. is vastly well suited for joining the parts of the long corner posts of spires and other wooden towers. Fig. 25., No. 2., differs from No. 1. only by having three keys. The principal and the longitudinal strength are the same. The long scarf of No. 2., tightened by the three keys, enables it to resist a bending much better.

None of these scarfed tie-beams can have more than one-third of the strength of an entire piece, unless with the assistance of iron plates; for if the key be made thinner than one-third, it has less than one-third of the fibres to pull by.

We are confident, therefore, that when the heads of the bolts are connected by plates, the simple form of fig. 24. No. 1. is stronger than those more ingenious scarfings. It may be strengthened against lateral bending by a little tongue, or by a sally; but cannot have both.

The strongest of all methods of piecing a tie-beam would be to set the parts end to end, and grasp them between other pieces on each side, as in fig. 27. Plate LI. This is what the ship-carpenter calls *fishing* a beam; and is a frequent practice for occasional repairs. Mr Perronet used it for the tie-beams or stretchers, by which he connected the opposite feet of a centre, which was yielding to its load, and had pushed aside one of the piers above four inches. Six of these not only withstood a strain of 1800 tons, but, by wedging behind them, he brought the feet of the truss $2\frac{1}{2}$ inches nearer. The stretchers were 14 inches by 11 of sound oak, and could have withstood three times that strain. Mr Perronet, fearing that the great length of the bolts employed to connect the beams of these stretchers would expose them to the risk of bending, scarfed the two side pieces into the middle piece. The scarfing was of the triangular kind (*Trait de Jupiter*), and only an inch deep, each face being two feet long, and the bolt passed through close to the angle.

Fishing a Beam.

In piecing the pump rods, and other wooden stretchers of great engines, no dependence is had on scarfing; and the engineer connects every thing by iron straps. We doubt the propriety of this, at least in cases where the bulk of the wooden connexion is not inconvenient. These observations

Carpentry.

must suffice for the methods employed for connecting the parts of a beam; and we now proceed to consider what are more usually called the joints of a piece of carpentry.

Where the beams stand square with each other, and the strains are also square with the beams, and in the plane of the frame, the common mortise and tenon is the most perfect junction. A pin is generally put through both, in order to keep the pieces united, in opposition to any force which tends to part them. Every carpenter knows how to bore the hole for this pin, so that it shall draw the tenon tight into the mortise, and cause the shoulder to butt close, and make neat work: and he knows the risk of tearing out the bit of the tenon beyond the pin, if he draw it too much. We may just observe, that square holes and pins are much preferable to round ones for this purpose, bringing more of the wood into action, with less tendency to split it. The ship-carpenters have an ingenious method of making long wooden bolts, which do not pass completely through, take a very fast hold, though not nicely fitted to their holes, which they must not be, lest they should be crippled in driving. They call it *foxtail wedging*. They stick into the point of the bolt a very thin wedge of hard wood, so as to project a proper distance; when this reaches the bottom of the hole by driving the bolt, it splits the end of it, and squeezes it hard to the side. This may be practised with advantage in carpentry. If the ends of the mortise are widened inwards, and a thin wedge be put into the end of the tenon, it will have the same effect, and make the joint equal to a dovetail. But this risks the splitting the piece beyond the shoulder of the tenon, which would be unsightly. This may be avoided as follows: Let the tenon T, fig. 28. have two very thin wedges *a* and *c* struck in near its angles, projecting equally: at a very small distance within these, put in two shorter ones *b*, *d*, and more within these if necessary. In driving this tenon, the wedges *a* and *c* will take first, and split off a thin slice, which will easily bend without breaking. The wedges *b*, *d*, will act next, and have a similar effect, and the others in succession. The thickness of all the wedges taken together must be equal to the enlargement of the mortise toward the bottom.

When the strain is transverse to the plane of the two beams, the principles laid down in No. 85, 86, of the article STRENGTH OF MATERIALS, will direct the artist in placing his mortise. Thus the mortise in a girder for receiving the tenon of a binding joist of a floor should be as near the upper side as possible, because the girder becomes concave on that side by the strain. But as this exposes the tenon of the binding-joist to the risk of being torn off, we are obliged to mortise farther down. The form (fig. 29.) generally given to this joint is extremely judicious. The sloping part *a b* gives a very firm support to the additional bearing *e d*, without much weakening of the girder. This form should be copied in every case where the strain has a similar direction.

The joint that most of all demands the careful attention of the artist is, that which connects the ends of beams, one of which pushes the other very obliquely, putting it into a state of extension. The

Square Joints.

Fox-tail Wedging.

Oblique Mortise and Tenon.

Carpentry. most familiar instance of this is the foot of a rafter pressing on the tie-beam, and thereby *drawing* it away from the other wall. When the direction is very oblique (in which case the extending strain is the greatest), it is difficult to give the foot of the rafter such a hold of the tie-beam as to bring many of its fibres into the proper action. There would be little difficulty if we could allow the end of the tie-beam to project to a small distance beyond the foot of the rafter: but, indeed, the dimensions which are given to tie-beams, for other reasons, are always sufficient to give enough of abutment when judiciously employed. Unfortunately this joint is much exposed to failure by the effects of the weather. It is much exposed, and frequently perishes by rot, or becomes so soft and friable that a very small force is sufficient, either for pulling the filaments out of the tie-beam, or for crushing them together. We are therefore obliged to secure it with particular attention, and to avail ourselves of every circumstance of construction.

One is naturally disposed to give the rafter a deep hold by a long tenon; but it has been frequently observed in old roofs that such tenons break off. Frequently they are observed to tear up the wood that is above them, and push their way through the end of the tie-beam. This in all probability arises from the first sagging of the roof, by the compression of the rafters and of the head of the king-post. The head of the rafter descends, the angle with the tie-beam is diminished by the rafter revolving round its step in the tie-beam. By this motion the heel or inner angle of the rafter becomes a fulcrum to a very long and powerful lever much loaded. The tenon is the other arm, very short, and being still fresh, it is therefore very powerful. It therefore forces up the wood that is above it, tearing it out from between the cheeks of the mortise, and then pushes it along. Carpenters have therefore given up long tenons, and give to the toe of the tenon a shape which abuts firmly, in the direction of the thrust, on the solid bottom of the mortise, which is well supported on the under side by the wall plate. This form has the farther advantage of having no tendency to tear up the end of the mortise. This form is represented in fig. 30. The tenon has a small portion *ab* cut perpendicular to the surface of the tie-beam, and the rest *bc* is perpendicular to the rafter. (See Note CC.)

But if the tenon is not sufficiently strong (and it is not so strong as the rafter, which is thought not to be stronger than is necessary), it will be crushed, and then the rafter will shade out along the surface of the beam. It is therefore necessary to call in the assistance of the whole rafter. It is in this distribution of the strain among the various abutting parts that the varieties of joints and their merits chiefly consist. It would be endless to describe every nostrum, and we shall only mention a few that are most generally approved of.

The aim in fig. 31. is to make the abutments exactly perpendicular to the thrusts. (See Note CC.) It does this very precisely; and the share which the tenon and the shoulder have of the whole may be what we please, by the portion of the beam that we notch down. If the wall plate lie duly before the

heel of the rafter, there is no risk of straining the tie across or breaking it, because the thrust is made to direct to that point where the beam is supported. The action is the same as against the joggle on the head or foot of a king-post. We have no doubt but that this is a very effectual joint. It is not, however, much practised. It is said that the alosing seam at the shoulder lodges water; but the great reason seems to be a secret notion that it weakens the tie-beam. If we consider the direction in which it acts as a tie, we must acknowledge that this form takes the best method for bringing the whole of it into action.

Fig. 32. exhibits a form that is more general, but certainly worse. What part of the thrust that is not borne by the tenon acts obliquely on the joint of the shoulder, and gives the whole a tendency to rise up and slide outward.

The shoulder joint is sometimes formed like the dotted line *abcdefg* of fig. 32. This is much more agreeable to the true principle, and would be a very perfect method, were it not that the intervals *bd* and *df* are so short that the little wooden triangles *bd*, *df*, will be easily pushed off their bases *bd*, *df*.

Fig. 33. No. 1. seems to have the most general approbation. It is the joint recommended by Price, and copied into all books of carpentry as the *true joint* for a rafter foot. The visible shoulder-joint is flush with the upper surface of the tie-beam. The angle of the tenon at the tie nearly bisects the obtuse angle formed by the rafter and the beam, and is therefore somewhat oblique to the thrust. The inner shoulder *ac* is nearly perpendicular to *bd*. The lower angle of the tenon is cut off horizontally as at *ed*. Fig. 34. is a section of the beam and rafter foot, showing the different shoulders.

We do not perceive the peculiar merit of this joint. The effect of the three oblique abutments, *ab*, *ac*, *ed*, is undoubtedly to make the whole bear on the outer end of the mortise, and there is no other part of the tie-beam that makes immediate resistance. Its only advantage over a tenon extending in the direction of the thrust is, that it will not tear up the wood above it. Had the inner shoulder had the form *eci*, having its face *ic* perpendicular, it would certainly have acted more powerfully in stretching many filaments of the tie-beam, and would have had much less tendency to force out the end of the mortise. The little bit *ci* would have prevented the sliding upwards along *ec*. At any rate, the joint *ab* being flush with the beam, prevents any sensible abutment on the shoulder *ac*.

Fig. 33. No. 2. is a simpler, and in our opinion a preferable, joint. We observe it practised by the most eminent carpenters for all oblique thrusts; but it surely employs less of the cohesion of the tie-beam than might be used without weakening it, at least when it is supported on the other side by the wall plate.

Fig. 33. No. 3. is also much practised by the first carpenters.

Fig. 35. No. 1. is proposed by Mr Nicholson as preferable to fig. 33. No. 3., because the abutment of the inner part is better supported. This is certainly the case; but it supposes the whole

Most approved
Forms.

carpentry. rafter to go to the bottom of the socket, and the beam to be thicker than the rafter. Some may think that this will weaken the beam too much, when it is no broader than the rafter is thick; in which case they think that it requires a deeper socket than Nicholson has given it. Perhaps the advantages of Nicholson's construction may be had by a joint like fig. 35. No. 2.

**con-
nec-
to
attend** Whatever is the form of these butting joints, great care should be taken that all parts bear alike, and the artist will attend to the magnitude of the different surfaces. In the general compression, the greater surfaces will be less compressed, and the smaller will therefore change most. When all has settled, every part should be *equally* close. Because great logs are moved with difficulty, it is very troublesome to try the joint frequently to see how the parts fit; therefore we must expect less accuracy in the interior parts. This should make us prefer those joints whose efficacy depends chiefly on the visible joint.

It appears from all that we have said on this subject, that a very small part of the cohesion of the tie-beam is sufficient for withstanding the horizontal thrust of a roof, even though very low pitched. If therefore no other use is made of the tie-beam, one much slenderer may be used, and blocks may be firmly fixed to the ends, on which the rafters might abut, as they do on the joggles on the head and foot of a king-post. Although a tie-beam has commonly floors or ceilings to carry, and sometimes the workshops and store-rooms of a theatre, and therefore requires a great scantling, yet there frequently occur in machiaes and engines very oblique stretchers, which have no other office, and are generally made of dimensions quite inadequate to their situation, often containing ten times the necessary quantity of timber. It is therefore of importance to ascertain the most perfect manner of executing such a joint. We have directed the attention to the principles that are really concerned in the effect. In all hazardous cases, the carpenter calls in the assistance of iron straps; and they are frequently necessary, even in roofs, notwithstanding this superabundant strength of the tie-beam. But this is generally owing to bad construction of the wooden joint, or to the failure of it by time. Straps will be considered in their place.

There needs but little to be said of the joints at a joggle worked out of solid timber; they are not near so difficult as the last. When the size of a log will allow the joggle to receive the whole breadth of the abutting brace, it ought certainly to be made with a square shoulder; or, which is still better, an arch of a circle, having the other end of the brace for its centre. (See Note E.E.) Indeed this in general will not sensibly differ from a straight line perpendicular to the brace. By this circular form, the settling of the roof makes no change in the abutment; but when there is not sufficient stuff for this, we must avoid bevel joints at the shoulders, because these always tend to make the brace slide off. The brace in fig. 36. No. 1. must not be joined as at *b*, but as at *a*, or some equivalent manner. Observe

VOL. II. PART II.

the joints at the head of the main posts of Drury Lane Theatre, Fig. 41. Plate LIII.

Carpentry. When the very oblique action of one side of a frame of carpentry does not extend but compress the piece on which it abuts (as in fig. 11.), there is no difficulty in the joint. Indeed a joining is unnecessary, and it is enough that the pieces abut on each other; and we have only to take care that the mutual pressure be equally borne by all the parts, and that it do not produce lateral pressures, which may cause one of the pieces to slide on the butting-joint. A very slight mortise and tenon is sufficient at the joggle of a king post with a rafter or straining beam. It is best, in general, to make the butting plain, bisecting the angle formed by the sides, or else perpendicular to one of the pieces. In fig. 36. No. 2. where the straining beam *ab* cannot slip away from the pressure, the joint *a* is preferable to *b*, or indeed to any uneven joint, which never fails to produce very unequal pressures on the different parts, by which some are crippled, others are splintered off, &c.

**Directions
for placing
Iron Straps.** When it is necessary to employ iron straps for strengthening a joint, a considerable attention is necessary, that we may place them properly. The first thing to be determined is the direction of the strain. This is learned by the observations in the beginning of this article. We must then resolve this strain into a strain parallel to each piece, and another perpendicular to it. Then the strap which is to be made fast to any of the pieces, must be so fixed, that it shall resist in the direction parallel to the piece. Frequently this cannot be done; but we must come as near to it as we can. In such cases we must suppose that the assemblage yields a little to the pressures which act on it. We must examine what change of shape a small yielding will produce. We must now see how this will affect the iron strap which we have already supposed attached to the joint in some manner that we thought suitable. This settling will perhaps draw the pieces away from it, leaving it loose and unserviceable (this frequently happens to the plates which are put to secure the obtuse angles of butting timbers, when their bolts are at some distance from the angles, especially when these plates are laid on the inside of the angles); or it may cause it to compress the pieces harder than before; in which case it is answering our intention. But it may be producing cross strains, which may break them, or it may be crippling them. We can hardly give any general rules; but the reader will do well to read what is written in No. 36, and 41, of the article ROOF, (*Encycl.*) In No. 36, he will see the nature of the strap or stirrup, by which the king post carries the tie beam. The strap that we observe most generally ill-placed is that which connects the foot of the rafter with the beam. It only binds down the rafter, but does not act against its horizontal thrust. It should be placed farther back on the beam, with a bolt through it, which will allow it to turn round. It should embrace the rafter almost horizontally near the foot, and should be notched square with the back of the rafter. Such a construction is represented in fig. 37. By moving

4 M

Carpentry. round the eye bolt, it follows the rafter, and cannot pinch and cripple it, which it always does in its ordinary form. We are of opinion that straps which have eye-bolts in the very angles, and allow all motion round them, are of all the most perfect. A branched strap, such as may at once bind the king post and the two braces which butt on its foot, will be more serviceable if it have a joint. When a roof warps, those branched straps frequently break the tenons, by affording a fulcrum in one of their bolts. An attentive and judicious artist will consider how the beams will act on such occasions, and will avoid giving rise to these great strains by levers.—A skilful carpenter never employs many straps, considering them as auxiliaries foreign to his art, and subject to imperfections in workmanship which he cannot discern nor amend. We must refer the reader to Nicholson's *Carpenter and Joiner's Assistant* for a more particular account of the various forms of stirrups, screwed rods, and other iron work for carrying tie-beams, &c.

As for those that are necessary for the turning joints of great engines constructed of timber, they make no part of the art of carpentry. (See Note II.)

Examples of different Pieces of Carpentry.

Roof of Greenwich Chapel.

After having attempted to give a systematic view of the principles of framing carpentry, we shall conclude, by giving some examples which will illustrate and confirm the foregoing principles.

Fig. 38. Plate LII. is the roof of the chapel of the Royal Hospital at Greenwich, constructed by Mr S. Wyatt.

	Ticks
	Beantling.
AA, is the tie-beam, 57 feet long, spanning 51 feet clear,	14 by 12
CC, Queen posts,	9 x 12
D, Braces,	9 x 7
E, Straining beam,	10 x 7
F, Straining piece,	6 x 7
G, Principal rafters,	10 x 7
H, A cambered beam for the platform,	9 x 7
B, An iron string, supporting the tie-beam,	2 x 2

The trusses are 7 feet apart, and the whole is covered with lead, the boarding being supported by horizontal ledgers *h, h*, of 6 by 4 inches.

This is a beautiful roof, and contains less timber than most of its dimensions. The parts are all disposed with great judgment. Perhaps the iron rod is unnecessary; but it adds great stiffness to the whole.

The iron straps at the rafter feet would have had more effect if not so oblique. Those at the head of the post are very effective.

We may observe, however, that the joints between the straining beam and its braces are not of the best kind, and tend to bruise both the straining beam and the truss beam above it.

St Paul's, Covent Garden.

Fig. 39. The roof of St Paul's, Covent Garden, designed by Mr Hardwick, and constructed by Mr Wapshot in 1796.

AA, Tie-beam spanning 80 feet 2 inches	16 x 12
BB, Queen posts,	9 x 8
C, Straining beam,	10 x 8
D, King post (14 at the joggle),	9 x 8

EE, Struts,	8 x 7 1/2	Carpenter
FF, Auxiliary rafters (at bottom),	10 x 8 1/2	
HH, Principal rafter (at bottom),	10 x 8 1/2	
g g, Studs supporting the rafter,	8 x 8	

The trusses are about 10 feet 6 inches apart, and the dotted lines in the middle compartment show the manner in which the roof is framed under the cupola.

This roof far excels the original one put up by Inigo Jones. One of its trusses contains 198 feet of timber. One of the old roof had 273, but had many inactive timbers, and others ill disposed. The internal truss FCF is admirably contrived for supporting the exterior rafters, without any pressure on the far projecting ends of the tie-beam. The former roof had bent them greatly, so as to appear ungraceful. (See Note KK.)

We think that the catber (six inches) of the tie-beam is rather hurtful; because by settling, the beam lengthens; and this must be accompanied by a considerable sinking of the roof. This will appear by calculation. (See Note LL.)

Fig. 40. Plate LIII. the roof of Birmingham theatre, Birmingham constructed by Mr Geo. Saunders. The span is 80 feet clear, and the trusses are 10 feet apart.

A, Is an oak corbel,	9 x 5
B, Inner plate,	9 x 9
C, Wall Plate,	8 x 5 1/2
D, Pole plate,	7 x 5
E, Tie beam,	15 x 15
F, Straining beam	12 x 9
G, Oak king post (in the shaft),	9 x 9
H, Oak queen post (in the shaft),	7 x 9
I, Principal rafters,	9 x 9
K, Common ditto,	4 x 2 1/2
L, Principal braces,	9 and 6 x 9
M, Common ditto,	6 x 9
N, Purlins,	7 x 5
Q, Straining sill,	5 1/2 x 9
S, Ridge piece,	

This roof is a fine specimen of British carpentry, and is one of the boldest and lightest roofs in Europe. The straining sill Q, gives a firm abutment to the principal braces, and the space between the posts is 19 1/2 feet wide, affording roomy workshops for the carpenters and other workmen connected with a theatre. The contrivance for taking double hold of the wall, which is very thin, is excellent. There is also added a beam (marked R), bolted down to the tie-beams. The intention of this was to prevent the total failure of so bold a trussing, if any of the tie-beams should fail at the end by rot.

A kin to this roof is fig. 41. Plate LIII. the roof Drury-Lane of Drury-Lane theatre, 80 feet 3 inches in the clear, and the trusses 15 feet apart, constructed by Edward Grey Saunders.

A, Beams,	10 by 7
B, Rafters,	7 x 7
C, King posts,	12 x 7
D, Struts,	5 x 7
F, Purlins,	9 x 5
G, Pole plates,	5 x 6
H, Gutter plates framed into the beams,	12 x 6

Carpentry.	I, Common rafters,	5 × 4
	K, Tie-beam, to the main truss,	15 × 12;
	L, Posts to ditto,	15 × 12.
	M, Principal braces to ditto,	14 and 12 × 12;
	N, Struts,	8 × 12.
	P, Straining beams,	12 × 12.

tie-beam, a good way back.* All the parts are formed, and disposed with the precision of a person thoroughly acquainted with the subject; and we have not the smallest doubt of the success of the project, and the complete security and durability of his roofs. We abound in iron, but we must send abroad for building timber. This is therefore a valuable project; at the same time, however, let us not over-rate its value. Iron is but about 12 times stronger than red fir, and is more than 12 times heavier; nor is it cheaper, weight for weight, or strength for strength.

Carpentry.

The main beams are trussed in the middle space with oak trusses 5 inches square. This was necessary for its width of 32 feet, occupied by the carpenters, painters, &c. The great space between the trusses afford good store rooms, dressing rooms, &c.

It is probable that this roof has not its equal in the world for lightness, stiffness, and strength. The main truss is so judiciously framed, that each of them will safely bear a load of 300 tons; so it is not likely that they will ever be quarter loaded. The division of the whole into three parts makes the exterior roofings very light. The strains are admirably kept from the walls, and the walls are even firmly bound together by the roof. They also take off the dead weight from the main truss one third.

Remarks.

The intelligent reader will perceive that all these roofs are on one principle, depending on a truss of three pieces and a straight tie-beam. This is indeed the great principle of a truss, and is a step beyond the roof with two rafters and a king post. It admits of much greater variety of forms, and of greater extent. We may see, that even the middle part may be carried to any space, and yet be flat at top; for the truss-beam may be supported in the middle by an inverted king post (of timber, not iron), carried by iron or wooden ties from its extremities: and the same ties may carry the horizontal tie-beam K; for till K be torn asunder, or M, N, and P be crippled, nothing can fail.

The roof of St Martin's church in the Fields is constructed on good principles, and every piece properly disposed. But, although its span does not exceed 40 feet from column to column, it contains more timber in a truss than there is in one of Drury-Lane theatre. The roof of the chapel at Greenwich, that of St Paul's, Covent-Garden, that of Birmingham, and that of Drury-Lane theatre, form a series, gradually more perfect. Such specimens afford excellent lessons to the artists. We therefore account them a useful present to the public.

Project by Mr Nicholson.

There is a very ingenious project, offered to the public by Mr P. Nicholson, (*Carpenter's Assistant*, p. 68.) He proposes iron rods for king posts, queen posts, and all other situations where beams perform the office of ties. This is in prosecution of the notions which we published in the article *Roof* of the *Encyclopaedia*. He receives the feet of the braces and struts in a socket very well connected with the foot of his iron king post; and he secures the feet of his queen posts from being pushed inwards by interposing a straining sill. He does not even mortise the foot of his principal rafter into the end of the tie-beam, but sets it in a socket like a shoe, at the end of an iron bar, which is bolted into the

Our illustrations and examples have been chiefly taken from roofs, because they are the most familiar instances of the difficult problems of the art. We could have wished for more room even on this subject. The construction of dome roofs has been (we think) mistaken, and the difficulty is much less than is imagined. We mean in respect of strength; for we grant that the obliquity of the joints, and a general intricacy, increases the trouble of workmanship exceedingly. Wooden bridges form another class equally difficult and important; but our limits are already overpassed, and will not admit them. The principle on which they should all be constructed, without exception, is that of a truss, avoiding all lateral bearings on any of the timbers. In the application of this principle, we must farther remark, that the angles of our truss should be as acute as possible; therefore we should make it of as few, and of as long pieces as we can, taking care to prevent the bending of the truss beams by bridles, which embrace them, but without pressing them to either side. When the truss consists of many pieces, the angles are very obtuse; and the thrusts increase nearly in the duplicate proportion of the number of angles.

Wooden Bridges.

With respect to the frames of carpentry which occur in engines and great machines, the varieties are such that it would require a volume to treat of them properly. The principles are already laid down; and if the reader be really interested in the study, he will engage in it with seriousness, and cannot fail of being instructed. We recommend to his consideration, as a specimen of what may be done in this way, the working beam of Hornblower's steam engine. (See *STEAM-ENGINE*, in the *Encyclopaedia*.) When the beam must act by chains hung from the upper end of arch heads, the framing there given seems very scientifically constructed; at the same time, we think that a strap of wrought iron, reaching the whole length of the upper bar (see the figure), would be vastly preferable to those partial plates which the engineer has put there, for the bolts will soon work loose.

Framing of great levers.

But when arches are not necessary, the form employed by Mr Watt is vastly preferable, both for simplicity and for strength. It consists of a simple beam AB (fig. 42, Plate LIII.), having the gudgeon C on the upper side. The two piston rods are attached to wrought iron joints A and B. Two strong struts

* See figures 40, 41, 42, Plate LII., and Mr Nicholson's work, p. 68, where these figures are particularly described.

Carpentry. DC, EC rest on the upper side of the gudgeon, and carry an iron string ADEB, consisting of three pieces, connected with the struts by proper joints of wrought iron. A more minute description is not needed for a clear conception of the principle. No part of this is exposed to a cross strain; even the beam AB might be sawed through at the middle. The iron string is the only part which is stretched; for AC, DC, EC, BC, are all in a state of compression. We have made the angles equal, that all may be as great as possible, and the pressure on the struts and strings a minimum. Mr Watt makes them much lower, as $AdeB$, or $A\delta\epsilon B$. But this is for economy, because the strength is almost insuperable. It might be made with wooden strings; but the workmanship of the joints would more than compensate the cheapness of the materials.

We offer this article to the public with deference, and we hope for an indulgent reception of our essay on a subject which is in a manner new, and would require much study. We have bestowed our chief attention on the strength of the construction, because it is here that persons of the profession have the most scanty information. We beg them not to consider our observations as too refined, and that they will study them with care. One principle runs through the whole; and when that is clearly conceived and familiar to the mind, we venture to say that the practitioner will find it of easy application, and that he will improve every performance by a continual reference to it."

IV. NOTES.

AA. P. 629. This rule may be somewhat more accurately expressed in these words: From the point at which any three forces meet and balance each other, draw a line in the actual direction of any one of them, and from the extremity of this line draw two others, parallel to the directions of the other two forces respectively; then supposing the pieces affording these two forces to be produced indefinitely at their remoter ends, either of them which is cut by one of the two lines will be compressed, and act as a brace, and either of them which is not cut will be stretched, and act as a tie.

BB. P. 630. It is however difficult to imagine how the beam DA can furnish a force iA , to prevent the force Af from carrying the beam BA towards H, when DA only affords a repulsive abutment. The true resolution of the force AE is found by considering the intersection of GE with Ae, which are the directions of the separate forces composing it; these lines meeting in a point a little above r , we may call their intersection r^* ; then in the triangle AEr*, the side Ar* will represent the pressure on the mitred joint, and r^*E the pressure on the beam HD; and the former being again resolved into AG and Gr*, we have ultimately AG and $Gr^* + r^*E = GE = AF$, for the horizontal and vertical forces, however they may be modified by intermediate combinations.

CC. P. 631. The reasoning contained in this and some of the subsequent articles may serve as an approximation to the truth in many cases of common occurrence; but the supposition, on which it is

founded, is by no means generally admissible as affording a result mathematically accurate: for in reality, the distribution of the weight of a roof over the whole extent of the rafters, or the concentration of the whole weight in the point where they meet, is far from being an indifferent alternative, either with respect to the magnitude of the thrusts, or to the proper directions of the abutments or joints. In the case here discussed, where there is no king post, it is clear that the centre of gravity of the whole roof must be much nearer to the middle of the figure than the angular point, and that consequently the weights, supported by the two walls, will be very different from those which would be supported, if the whole load were placed at the summit: although, where there is a heavy king post, supporting also, as it ought to do, about half the weight of the tie beam, with its floors or cieling, the case will approach much nearer to the supposition here assumed.

For a common light roof, without a king post, the calculation or construction is very simple. When two rafters only meet at the summit, they must support each other by a horizontal thrust (see Art. BRIDGE, Prop. Y): and this thrust, acting on each rafter as a lever, of which the lower end is the fulcrum, must be equivalent to the weight, acting at the horizontal distance of the centre of gravity from the fulcrum, which is a quarter of the whole span; consequently the thrust must be to the weight as a quarter of the span to the height, and the compound oblique thrust on the abutment will be represented by the hypotenuse of the triangle of which those lines are the sides: so that if we had a roof of the same height, and of half the breadth, the direction of its rafters would exactly represent the actual direction of the compound thrust on the end of the tie beam, and would consequently indicate the proper form for the abutment of the given structure.

But in the case of the unequal rafters represented in the figure, the determination becomes more complicated, and we must first find the direction of the mutual thrust of the rafters, which must evidently be such, that the perpendiculars falling on it from each end of the tie beam may be in the inverse proportion of the motive powers of the weights of the rafters, that is, of the products of those weights into the horizontal distances of the centres of gravity from the respective fulcrums, or into the segments of the tie beam made by a vertical line passing through the summit, which are proportional to these distances; and if we produce the base of the triangle, and find in it a point, of which the distance is to the length of the tie beam, as the smaller product to the difference of the products, a line drawn from the summit to this point will show the true direction of the thrust; and its magnitude may then be readily determined, by dividing either of the products by the respective perpendicular falling on this line.

Where, however, there is a king post supporting a heavy tie beam, it is necessary to determine the centre of gravity of the half roof, together with this addition; and the distance of the centre of gravity from the middle will then be to the half span, as the weight of one of the rafters with its load is to the weight of the whole roof, including the tie beam and

Carpentry.

cieling; and if we erect a perpendicular passing through the centre of gravity thus found, and equal to the height, the oblique thrust on the abutment will be in the direction of the line joining the upper end of this perpendicular and the end of the tie beam.

DD. P. 634. In order to obtain a distinct idea of the operation of the forces concerned in this experiment, we must have recourse to Proposition C of this article, and substitute in the formula for the

$$\text{deflection } d = at \sqrt{\frac{M}{16f}} \text{TANG} \left(\sqrt{\frac{16f \cdot c}{M \cdot a}} \right), a=1, t = \frac{8}{6720} = \frac{1}{840}, M = 1,900,000 \text{ pounds, the specific}$$

gravity of fir being .56, $f = 6720$, and $c = 6$, the middle of the pillar being considered as the fixed point: we then find $\sqrt{\frac{16f \cdot c}{M \cdot a}} = 1.427$, which is the

length of an arc of $81^{\circ} 45'$, and the tangent becomes 6.9 , whence we have $d = \frac{1}{840} \times 4.2 \times 6.9 = .0345$,

or somewhat more than the thirtieth of an inch: consequently the strength must have been reduced in the proportion of 1.207 to 1. (Art. BRIDGE, Prop. E.) But, considering how near the arc thus determined approaches to a quadrant, it is obvious that any slight variations of the quantities concerned in the calculation must have greatly affected the magnitude of the tangent: so that the loss of strength may easily have been considerably greater than this, as it appears to have been found in the experiment. It would however scarcely have been expected that such a pillar, however supported, could withstand the pressure of 90 hundred weight, since Emerson informs us that the cohesive strength of a pillar of fir an inch in diameter is only about 35: but supposing the facts correct, the coincidence tends to show the near approach to equality of the forces of cohesion and lateral adhesion, as explained in the Introduction to this article.

EE. P. 635. A similar remark of the author has already been noticed in the article BRIDGE, at the end of the fifth section. In the form in which it is here expressed, it becomes still more objectionable: for with whatever part of a circular abutment a rafter equal to the radius may be brought into contact, it is very plain that its opposite end can never be either higher or lower than the original centre of curvature: and even if the curvature were made twice as great, so that the rafter might be equal to the diameter of the circle, it would be necessary that the lower end should slide upwards on the abutment as much as the upper end fell, in order to preserve the contact; and there would obviously be no force in the structure capable of producing such a change as this. Any general curvature of the joint must therefore be totally useless; but a judicious workman will make it somewhat looser below than above, when there is any probability that the rafters will sink, taking care however to avoid all bearing too near the surface, lest it should splinter; and for these reasons

Carpentry.

combined, making the end a little prominent somewhat above the middle of the surface which rests on the abutment.

With this precaution, the direction of the joint between a rafter and a tie beam ought to be made precisely perpendicular to the true thrust of the rafter, determined as already explained (Note CC): for in the first place, unless we trust either to the friction or to straps, the bearing cannot be more nearly horizontal than this, without danger of the rafters sliding outwards; and in the second place, if we made it more nearly vertical, we should lessen the vertical pressure on the end of the tie beam, immediately beyond the joint; a pressure which gives firmness to the wood, by pressing its fibres more closely together, and increasing their lateral adhesion or rather internal friction. If however the tie beam were not deep enough to receive the whole of the rafter so terminated, without too great a reduction of its depth, it would be proper to make the joint a little flatter, or more horizontal, and to restrain the end from sliding upwards by an iron strap fixed in a proper direction. We should preserve the end of the rafter as little diminished in breadth as possible, when the tie beam is wide enough to receive it; a moderate thickness, left on each side of the mortise in the tie beam, being sufficient to assist in securing the connexion of the ends of the beam with the intermediate parts.

FF. P. 635. The doctrine of the initial equality of the resistances to compression and extension, as stated in the article BRIDGE, enables us to demonstrate that the transverse strength can never exceed one sixth of that which would be derived from the resistance of all the fibres, cooperating at the distance of the whole depth from a fixed fulcrum, and acting with the weaker of the two powers appropriate to the body. It is true that the results of some direct experiments seem to favour the opinion that the cohesive power is the weaker; but where the flexure is already considerable, it is probable that this circumstance materially diminishes the primitive power of resisting compression, so that the principles, on which the calculation proceeds, are by no means strictly applicable to the case of a bar so broken.

GG P. 636. There seems to be a little confusion in the idea of the possibility of altering the nature of the action of the fibres of a beam by altering the place of the gudgeon in this manner: but the author has very properly abstained from making any practical application of the supposed modification thus introduced. With respect to the strength required for scarfing or joggling, it may be observed, that the whole of the compressed fibres of the concave side may be considered as abutting against the whole of the extended fibres on the convex side; and this abutment is equally divided throughout the length of the beam: so that if the scarfings or joggles in the whole length of the arm of a lever, taken together, are as strong as one half of the depth of the lever, exerting half its powers, from the inequality of tension, there will be no danger of the failing of these joints; and from this principle it will be easy

Carpentry
Casiri.

to determine the depth to which the joints ought to extend in any particular case. Hence also we may understand how a beam may become so short as to be incapable of transverse fracture in its whole extent: for the lateral adhesion between the different fibres of wood is generally far inferior to the longitudinal strength of the fibres; and if, for example, it were only one fourth as great, a beam less than twice as long as it is deep would separate, if urged in the middle by a transverse force, into two strata, from its incapacity of affording sufficient abutment, before its longitudinal fibres would give way.

HL. P. 638. If the bolts were sufficiently numerous, and sufficiently firm, so as to produce a great degree of adhesion or of friction between the parts, this joint might be made almost as strong as the entire beam, since there is nothing to prevent the co-operation of each side with the other throughout its extent: but much of the strength would be lost if the bolts became loose, even in an inconsiderable degree.

II. P. 642. The author has reasoned upon the direction of straps, as if it were universally necessary to economize their immediate strength only, without regard to the effect produced on the tightness of the joint: but it may happen that the principal purpose of the strap will be answered by its pressing the rafter firmly upon the beam, and this effect may be pro-

duced by a certain deviation from the horizontal position, with but little diminution of the strength of the strap: a deviation which has also the advantage of allowing the strap to embrace the whole of the beam, without weakening it by driving a bolt through it. We must not however endanger the crippling of the end of the beam, and the straps represented in fig. 38. may be allowed to be somewhat too erect.

KK. P. 642. It does not appear to be desirable that the ends of the rafters should be supported without any pressure on the ends of the beams, since these ends would bear a small weight without any danger of bending, and would thus lessen the pressure on the king post.

LL. P. 642. The half length being 25 feet, and the camber 6 inches, the excess of the oblique length will be $\sqrt{625.25} - 25$, or $\frac{1}{10}$ of a foot, that is, $\frac{1}{8}$ of an inch, which is all that the beam would appear to lengthen in sinking; nor would the settling of the roof be more "considerable" than about a quarter of an inch. But there seems to be no advantage in this deviation of the tie beam from the rectilinear direction; and the idea, which appears to be entertained by some workmen, that a bent beam partakes of the nature of an arch, is one of the many mischievous fallacies, which it is the business of the mathematical theory of Carpentry to dispel.

(O. R.)

CASIRI (MICHAEL), a very learned Orientalist, of the sect of Syrian Christians called Maronites, was born at Tripoli in Syria in the year 1710. As the sect of Maronites were subject to the Pope, Casiri came to study at Rome, and entered into holy orders in 1734. In the following year he proceeded to Syria to assist at a Synod of the Maronites. He returned to Rome in 1738, and for ten years thereafter taught the brethren of his convent to read Arabic, Syriac, and Chaldaic, giving lectures also in Philosophy and Theology. In 1748 he passed into Spain, upon the invitation of Ravago, Confessor to Ferdinand VI., and was by his means employed in the Royal Library at Madrid. In 1749 he was named a member of the *Royal Academy of History*; in 1756, he was appointed *Interpreter of Eastern Languages* to the King; and soon thereafter joint Librarian of the Escorial, with a royal pension of 200 piastres, besides the ordinary emoluments of the office. In 1763 he became principal Librarian, a situation which he appears to have held till his death in 1791. (*Biographie Universelle*.)

The only work which entitles Casiri's name to be recorded among the benefactors of Literature is his celebrated *Catalogue of the Arabic Manuscripts* preserved in the Library of which he was Keeper. This rare and curious work, entitled *Bibliotheca Arabico-Hispana Escorialensis*, was published in two volumes, folio, at Madrid, the first volume in 1760, and the second ten years thereafter. Mr Gibbon expresses himself "happy in possessing a copy of this splendid and interesting work," which constitutes, indeed, one of the most valuable contri-

utions that modern Europe has yet furnished towards the illustration of Eastern literature. By means of it, the literary treasures of the Escorial Library, the richest perhaps in Europe in the works of Arabic writers, are in a manner shared with the learned of other countries; thus affording an example, which it were to be wished, all other countries possessing similar treasures would imitate. The judicious manner in which it is compiled renders it a sort of digest of the attainments of the Saracens in science and literature during the most flourishing eras of their Empire. Its contents, as Mr Barington observes, "may indeed, under some of its heads, principally regard Spain; but they will, however, be found adequately to represent the general standard of learning, in its full extent and character, whether at Cordova or Fez, at Cairo or at Bagdad." (*Literary History of the Middle Ages*, p. 652.)

The manuscripts described amount to above eighteen hundred, and are classed in the following order: Grammar, Rhetoric, Poetry, Philology and Miscellanies, Lexicons, Philosophy, Politics, Medicine, Natural History, Jurisprudence, Theology, Geography, and History. The two last classes, with a copious Index, occupy the whole of the second volume. As a system of *Bibliography*, this arrangement of classes could not be allowed to be very perfect or scientific; but it was not the learned author's object to exhibit any such system; though some French Bibliographers seem to view his classification in that light, and express no small degree of wonder, that an Ecclesiastic, in the country of the Inquisition, should place so many classes before that

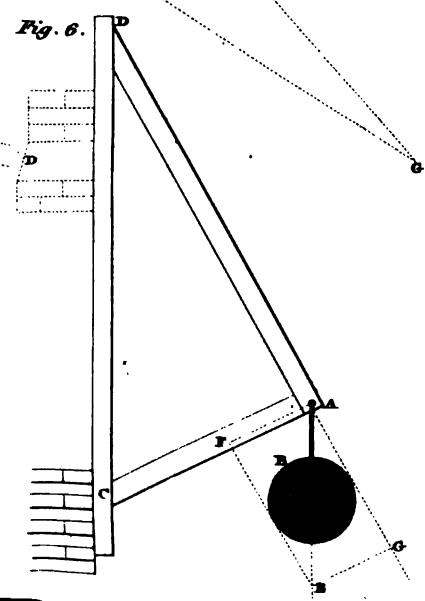
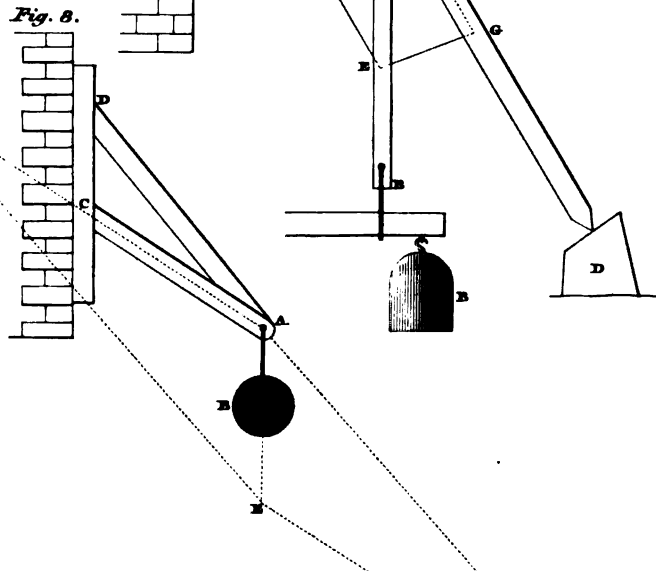
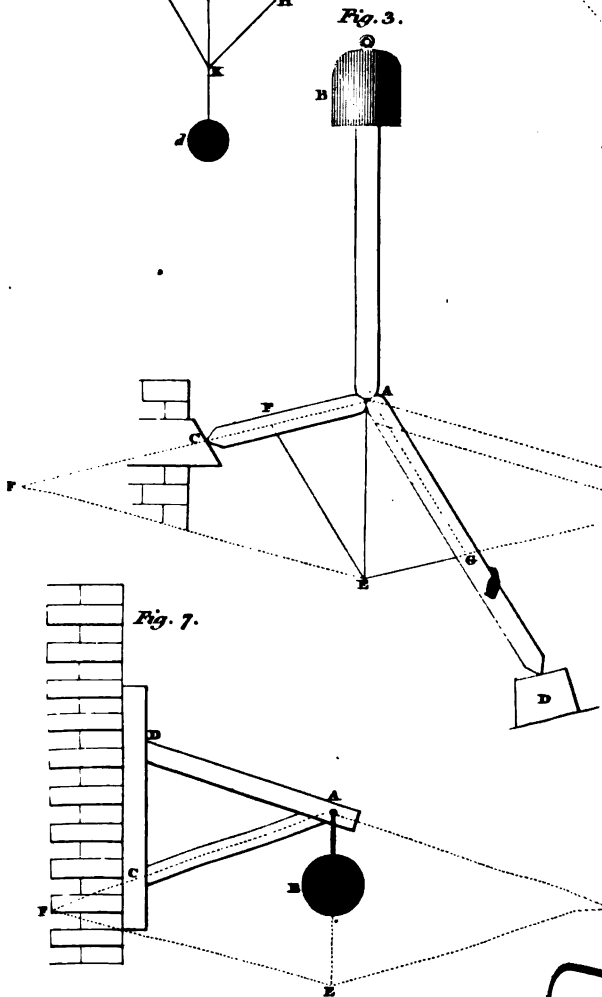
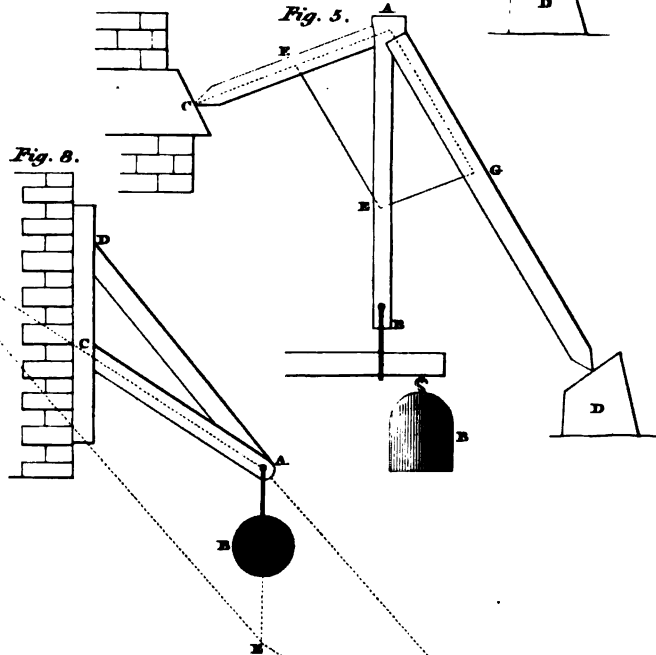
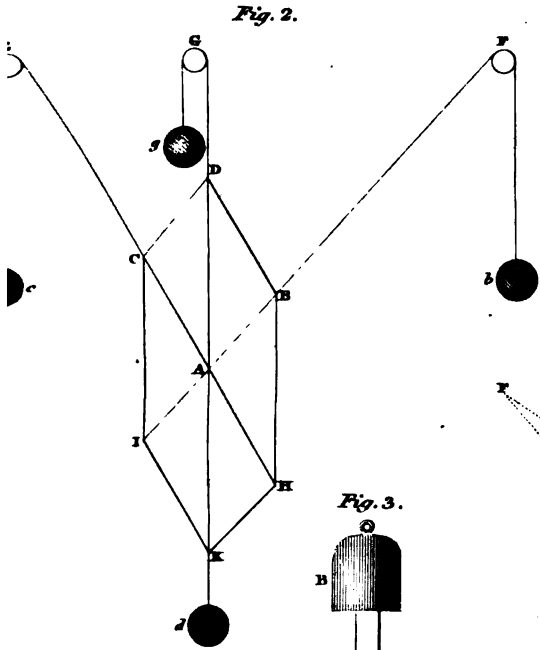
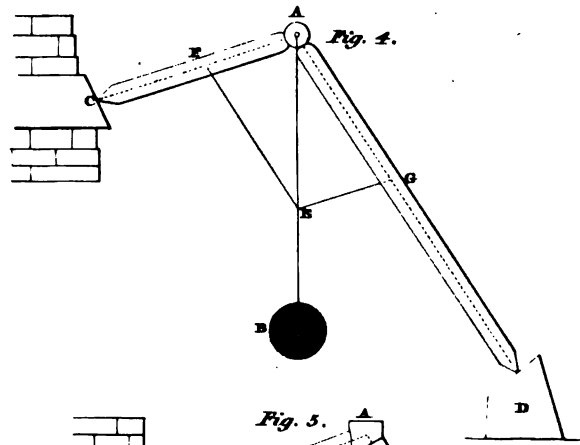
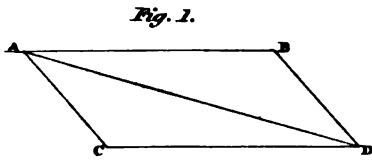

Edinburgh Publ

Engraved by W & D. Lithers Edinburgh

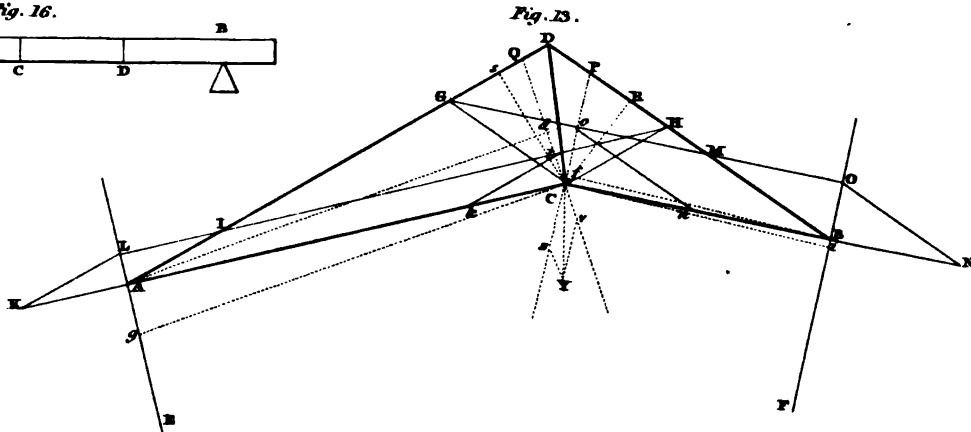
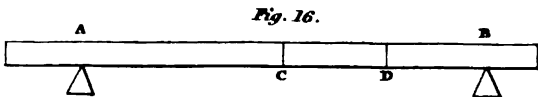
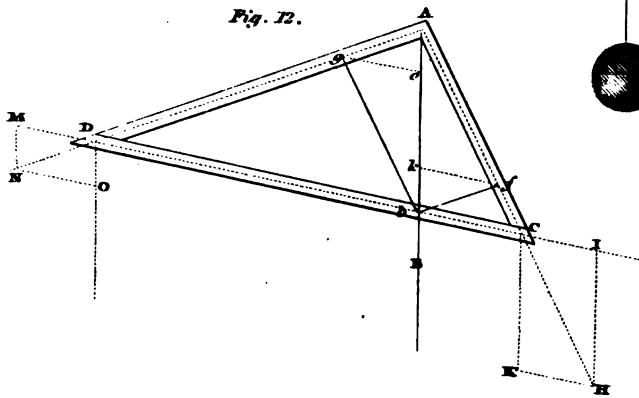
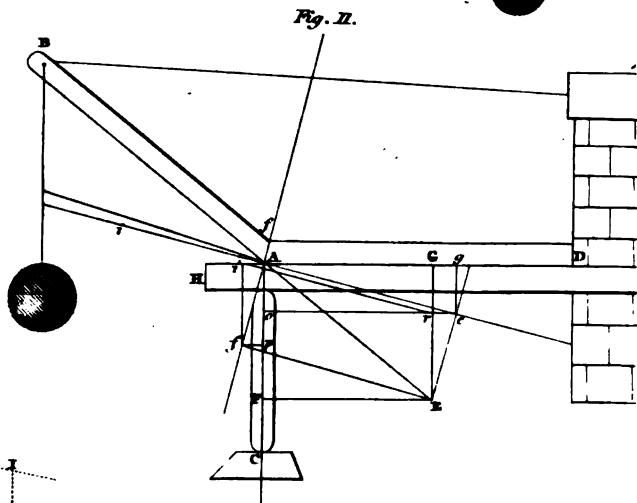
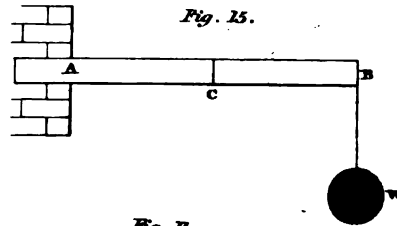
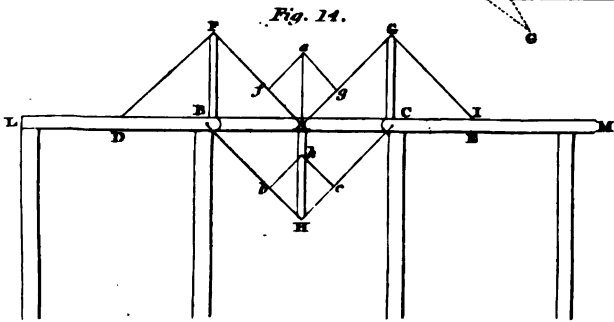
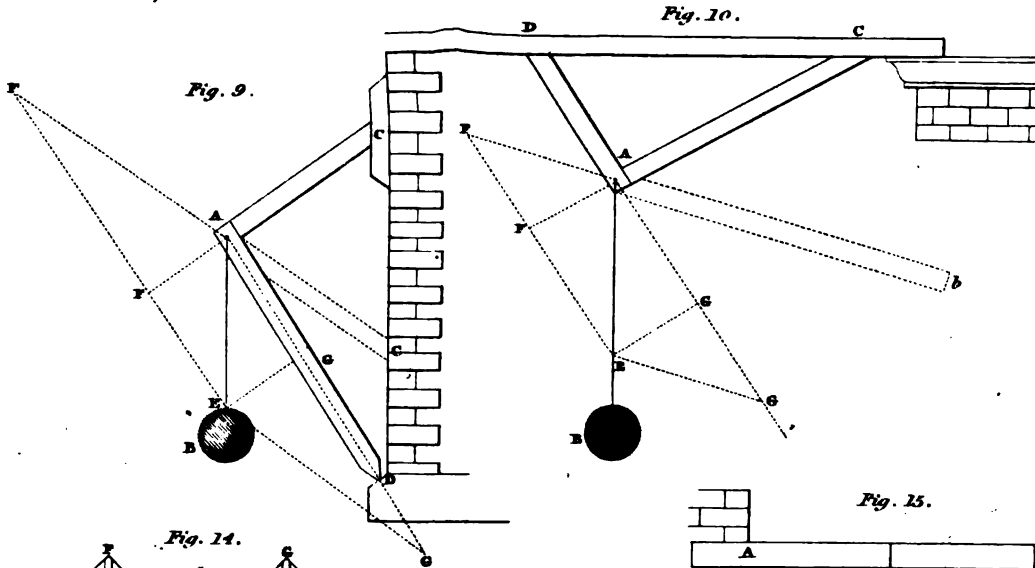

Fig. 17.



Fig. 18.



B



Fig. 19.



C



Fig. 22.

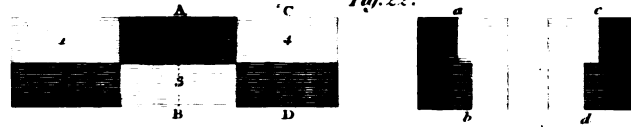

Fig. 21.



Fig. 23. N° 1.



Fig. 23. N° 2.

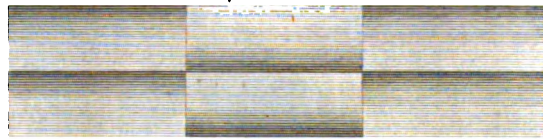

Fig. 20.



Fig. 24. N° 1.



Fig. 24. N° 2.



Fig. 24. N° 3.



Fig. 25. N° 1.



Fig. 26. N° 2.



Fig. 26.



Fig. 17.

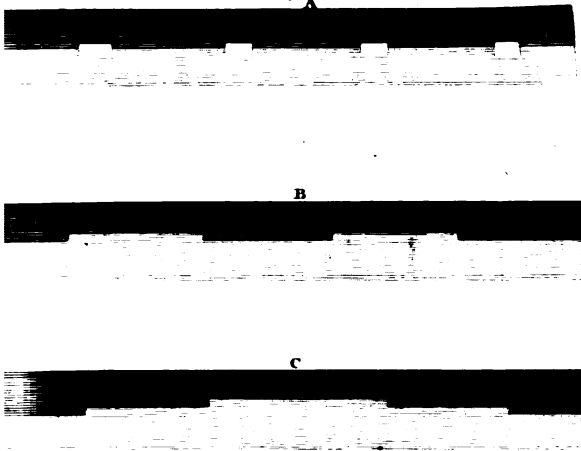

Fig. 18.



Fig. 19.



Fig. 22.

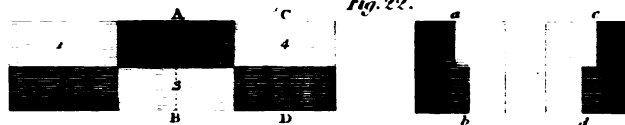

Fig. 21.

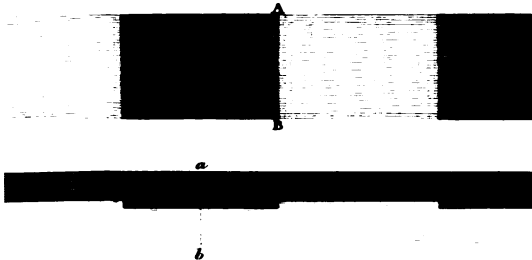

Fig. 23. N° 1.



Fig. 23. N° 2.



Fig. 20.



Fig. 24. N° 1.



Fig. 24. N° 2.



Fig. 24. N° 3.



Fig. 25. N° 1.



Fig. 25. N° 2.



Fig. 26.



Fig. 17.



B



Fig. 18.



Fig. 19.



Fig. 21.



a



b

Fig. 23. N° 1.

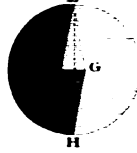

Fig. 22.

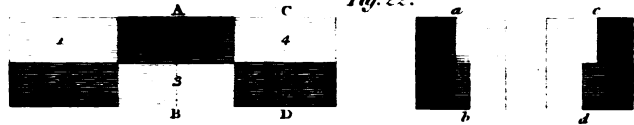

Fig. 23. N° 2.



Fig. 20.



Fig. 24. N° 1.



Fig. 24. N° 2.



Fig. 24. N° 3.



Fig. 25. N° 1.



Fig. 25. N° 2.



Fig. 26.



Fig. 17.



B



C

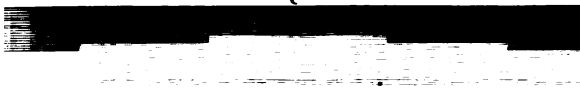

Fig. 18.



Fig. 19.



Fig. 22.

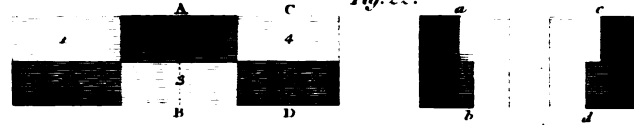

Fig. 21.



a

b



Fig. 23. N° 1.

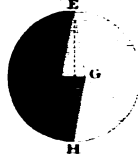

Fig. 23. N° 2.

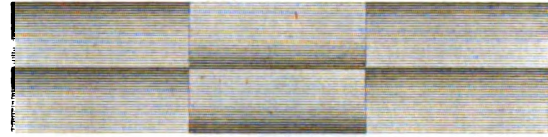

Fig. 20.

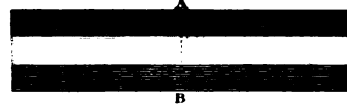

Fig. 24. N° 1.



Fig. 24. N° 2.



Fig. 24. N° 3.



Fig. 25. N° 1.



Fig. 26. N° 2.



Fig. 26.



Fig. 17.



Fig. 18.



B



Fig. 19.



C



Fig. 22.

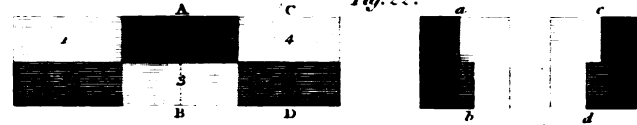

Fig. 21.



Fig. 23. N° 1.



Fig. 23. N° 2.

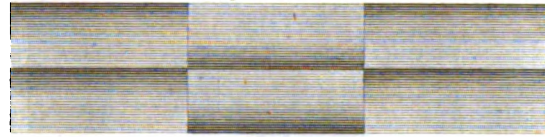

a



b

Fig. 20.



Fig. 24. N° 1.



Fig. 24. N° 2.



Fig. 24. N° 3.



Fig. 25. N° 1.



Fig. 25. N° 2.



Fig. 26.



Fig. 27.



Fig. 28.



Fig. 29.

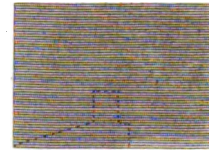

Fig. 34.

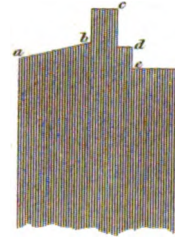
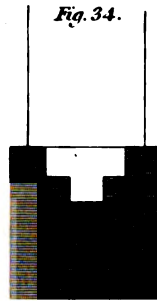

Fig. 33. N° 1.

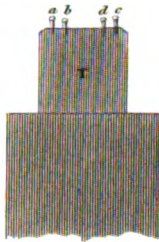
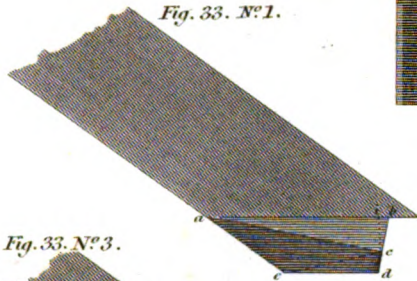

Fig. 33. N° 2.

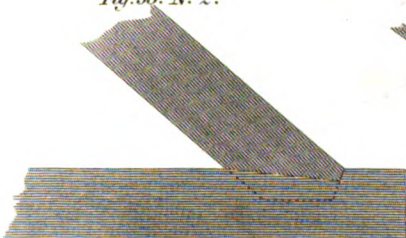

Fig. 33. N° 3.



Fig. 30.

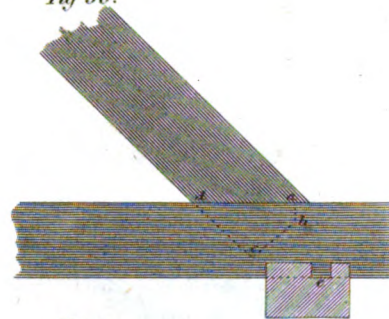

Fig. 32.

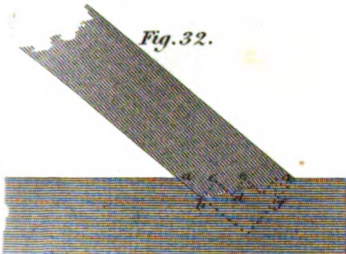

Fig. 37.

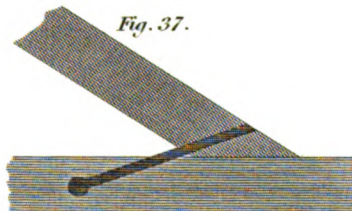

Fig. 31.

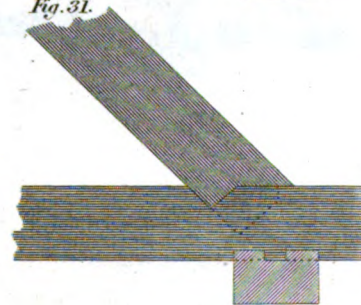

Fig. 36. N° 1.

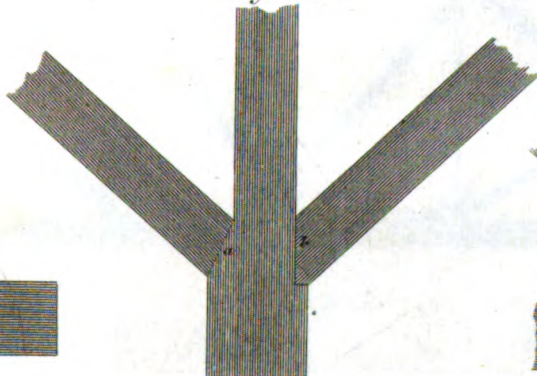

Fig. 35. N° 1.

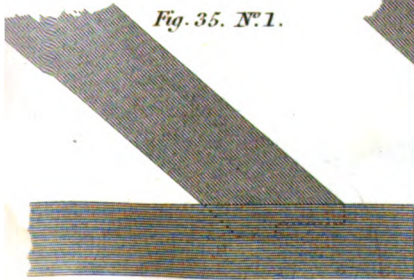

Fig. 35. N° 2.

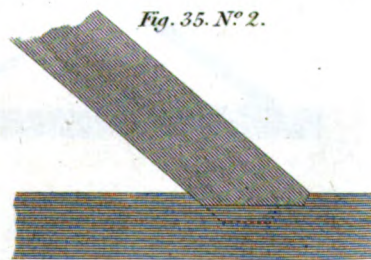
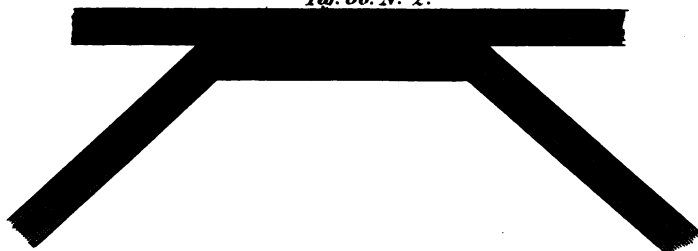

Fig. 36. N° 2.



Casiri
Caste.

of Theology, which in their systems generally holds the first place. The title of each Manuscript is given in the original Arabic, with a Latin translation, and its age and author, when these are known, are pointed out; but this is not all; the title and description of the work is frequently followed with extracts, also in Arabic and Latin, by which some of the most curious or peculiar features of the piece are brought before the reader; thereby supplying the want of the original, as well to those who could read it if accessible, as to those who could not read it though at hand. The learned author has also collected various interesting and authentic particulars of Saracenic Biography, and corrects some prevalent errors regarding the lives of these writers. We have noticed an error of this kind, in our account, derived from Casiri, of the celebrated Arabian Philosopher ALHAZEN, given in the first volume of this Supplement.

In the preface, which is of considerable length, Casiri gives a general view of his labours, and commemorates the assistance which he received from the Government and from the Learned. Rich as the Escorial is in Arabic Manuscripts, its present stores are small, compared to what they once were; for Casiri mentions that, by a fire which happened in 1670, more than *three thousand* of these interesting pieces were consumed. They who have not access to this valuable work, which is indeed but rarely to be met with, will find a full view of its contents, with some critical comments, in the *First Appendix* to Harris's *Philological Inquiries*, and in the *Second Appendix* to Barington's *Literary History of the Middle Ages*. The latter writer closes his review by stating it as his opinion, that the Arabian literature, though it greatly outshone ours during the same period, has experienced upon the whole too much prodigality of praise. This may perhaps be true; but this writer has failed, as abler writers likewise have, to furnish a sound and thorough estimate of the attainments and services to which the Arabians are fairly entitled to lay claim in regard to the culture and advancement of learning. The erudition of Gibbon, vast and varied as it was, did not nearly embrace all that was necessary to a full appreciation of this portion of literary history. His general view may be just, his criticisms penetrating and comprehensive; but he was ignorant of the language, and of some branches of science, without a proficiency in which, such an estimate could not be drawn up with any pretensions either to critical or philosophical accuracy. He who attempts, with requisite endowments, to supply that great desideratum—a literary history of the Saracens during the flourishing periods of their literature, will find the work of Casiri an invaluable assistant in such an undertaking.

Definition.

CASTE. By this term is here distinguished the classification and distribution of the members of a community into certain classes or orders, for the performance of certain functions; with the enjoyment of certain privileges, or the endurance of certain burthens; and the establishment of hereditary permanence in these orders, the son being ordained to perform the functions, to enjoy the privileges, or

sustain the burthens of the father, and to marry only in his own tribe, without mixture of the classes, in regular succession, through all ages.

Caste.

The term *Caste* is borrowed from the Portuguese. It was the term applied by that people, who first of the European nations formed establishments in India, to the classes which they found established upon this principle among the inhabitants of that portion of the globe; and from them, as it was from their intercourse that the rest of the nations of modern Europe first derived their familiarity with the manners and institutions of the people of India, the term made its way, and was established in the other languages of Europe.

The institution itself appears in the early ages of society to have been very extensively introduced.

In regard to the ancient Egyptians, the fact is universally and familiarly known. The President de Goguet, who, with singular industry, and no ordinary judgment and sagacity, explored the remains of ancient times, comprehends a great body of history in a few words. "We may farther observe," says he, "that, in the Assyrian empire, the people were distributed into a certain number of tribes, and that professions were hereditary; that is to say, children were not permitted to quit their father's occupation, and embrace another. We know not the time nor the author of this institution, which, from the highest antiquity, prevailed over almost all Asia, as well as in several other countries." It is not necessary here to surcharge the reader with the authorities which he quotes. The passage itself (P. i. B. i. Ch. l. Art. 3.) will be consulted by all who distrust the legitimacy of his inference, or desire to prosecute the inquiry.

It is stated in the common histories of Greece, that Cecrops distributed into four hereditary classes, or tribes, all the inhabitants of Attica. And we are informed by Plutarch, in his *Life of Theseus*, that by this prince, the class of priests, and that of nobles, in other words the magistrates or military leaders, were united into one: whence the society was composed of three classes; 1. The sacerdotal, legislating, and ruling class; 2. The class of husbandmen; and, 3. The class of tradesmen. "To the nobility," says the illustrious biographer, "he committed the choice of magistrates, the teaching and dispensing of the laws, and the interpretation of all holy and religious things; the whole city, as to all other matters, being as it were reduced to an exact equality; the nobles excelling the rest in honour, the husbandmen in profit, and the artificers in number. And Theseus was the first who, as Aristotle says, out of an inclination to popular government, parted with the regal power; which Homer also appears to attest, in his catalogue of the ships, where he gives the name of *PEOPLE* to the Athenians alone." There is a passage near the beginning of Plato's *Timæus*, which, though in a work of fancy, is not without some weight, as evidence either of conclusions which were drawn by men of research, or of traditions which were current among the people. In this passage, not only is it asserted, that, in the primeval state of the inhabitants of Attica, they resembled the Egyptians in the division into hereditary classes

Origin of the Term.

This Institution widely diffused.

Caste.

and professions; but a very accurate description is given of those classes, five in number; viz. 1. The class of priests; 2. The class of handicrafts; 3. The class of shepherds and hunters; 4. The class of ploughmen; 5. The military class. Πρωτον μιν το των ιερων γινος, απο των αλλων χωρις αφωρισμενον μετα δε ταυτο το των δημουργων, οτι καθ' αυτο ελασον, αλλη δε εκ επιμμεγμενων, δημουργο το τε των νομισων και των θρησκευτων το τε των γιωργων και δη το μαχιμον γινος, απο παντων των γενων καχωρισμενον, ος εδαν αλλο πλην τα περι τοι πολιμου υπο τε νομω προσεταχθη μελων.

We are informed by Aristotle, that the people of Crete were divided into castes, after the manner of the Egyptians, by the laws of Minos. Εοικε δε ε νυν αδη νωσθε. τωτ' ειναι γνωριμον τοις περι πολιτιας φιλοσοφωσι, οτι δεη δηρησθαι χωρις κατα γενη την πολιν, και το τε μαχιμον ιερον ειναι, και το γιωργον ειναι Αργυρατω τι γαρ εχει τον τροπον ταυτον οτι και νυν τα τε περι την Κρητην. Τα μιν εν περι Αργυρατων, Σισωεριοι, ος φασι, ετω νομοθετησαντος Μινω δε τα περι Κρητην. *Polit.* vii. 1.

It is worthy of observation, that certain vestiges at least of that ancient institution are still visible in Egypt. "La distinction par familles," says General Reynier (*De l'Egypte*, p. 56), "se retrouve encore dans les villes: l'exercice des arts et metiers est hereditaire: le fils imite les procedes de son pere, et ne les perfectionne pas."

We have a remarkable passage to prove, that, among the ancient Persians, the same division into castes existed which now has place among the Hindoos. In the *Zendavesta*, as translated by M. Anquetil Duperron, it is said: "Ormusd declared, There are three measures (literally weights, i. e. tests, rules) of conduct, four states, and five places of dignity. The states are, that of the priest; that of the soldier; that of the husbandman, the source of riches; and that of the artisan or labourer."—"We are told," says Sir John Malcolm (*Hist. of Persia*, i. 205), "that Jemsheed divided his subjects into four classes, and that he allotted to each a separate and fixed station in life; which seems to imply that the condition of the ancient Persians was like that of the modern Hindoos; and that the extraordinary institution of cast, which now exists in India, was once known in Persia." Sir John proceeds to state some reasons which induce him to doubt the reality of the fact; in not one of which, however, there is a particle of weight.

Sir John quotes, and translates for us a passage from Strabo, which asserts that a similar institution existed in Iberia. "Four kinds or classes of people inhabited that country. From what they consider the first class, they appoint their kings according to nearness of kindred and seniority; these administer justice, and head their armies: The second is of priests, who take charge of their political rights with respect to their neighbours: The third of soldiers and husbandmen: The fourth of the people in general, who are slaves of the king, and perform every menial office." This account of the distinctions of the castes is evidently incorrect, and by a man who was not well informed. The fact of the Iberians being distributed in a remarkable and uncommon manner, he knew; otherwise there would have been no occasion to single out the fact, in the description

of this particular people. He knew also that they were divided into four principal classes. With regard to the matters of detail, however, his words bear internal evidence that either his information had been vague and inaccurate, or that his recollection had become so.

From a dissertation of Mr Joinville, on the religion and manners of the people of Ceylon, (*Asiat. Researches*, vii. 430.) we find that there is sufficient evidence to prove the existence of a similar institution, anciently, among the Buddhists of Ceylon; and by consequence to infer it, among the other Buddhists, spread over so large a portion of Asia.

After this evidence of the general diffusion of the institution of castes, in the rude ages of the world, especially in Asia, there is a temptation, from the following passage of Herodotus, (Lib. I. cap. 101.) to infer its existence among the Medes, at the commencement of the monarchy. *Esi de Μηδων τωσδε γινωα, Βυσου, Παρηγασηνοι, Αδζατω, Βυδου, Μαγου.* There is nothing in the passage which serves to fix the meaning of the word *γινωα*; and the names, it is plain, are words of the ancient Median language. But we know that the *Μαγου* were the priests; and hence there is reason to conclude, that the other words also are names of classes and professions; in other words, of hereditary castes.

The institution of castes may be traced in places with which we are more intimately connected. Mr Millar, to whom the world is indebted for almost the first lessons which it received, in tracing the facts of history up to the general laws of the human mind, has called our attention to the fact, that in the ancient condition of our Saxon ancestors, they were divided into four great classes: 1. The artificers and tradesmen; 2. the husbandmen; 3. those who exercised the honourable profession of arms; and, 4. the clergy. Mr Millar adds, (*Hist. View of the English Gov.* B. i. ch. ii.) "From the natural course of things, it should seem, that, in every country, where religion has had so much influence as to introduce a great body of ecclesiastics, the people, upon the first advances made in agriculture and in manufactures, are usually distributed into the same number of classes or orders. This distribution is accordingly to be found, not only in all the European nations, formed upon the ruins of the Roman Empire; but, in other ages, and in very distant parts of the globe. The ancient inhabitants of Egypt are said to have been divided into the clergy, the military people, the husbandmen, and the artificers. The establishment of the four great castes, in the country of Indostan, is precisely of the same nature."

Human nature is very uniform in the phenomena which it exhibits. The new world displays a striking resemblance to the old. The same stage of society presents nearly the same results. There is reason to conclude, that something which resembled the institution of castes existed among the ancient inhabitants of Peru and Mexico. The Count Carl, the celebrated author of the *Lettres Americaines*, when treating (Lett. xiii. and xiv.) of the laws of the Peruvians says: "Les citoyens furent distribues en classes ou tribus. * * * Il n'etoit pas permis, ni par mariage, ni par changement d'habitation, de con-

Caste. fondre une classe avec l'autre : car la loi defendoit de se marier dans une autre famille que celle d'ou l'on sortoit. * * * N'oublions pas le soin qu'on avoit de l'education des enfans. C'etoit toujours le pere qui elevoit son fils. L'education consistoit à apprendre aux enfans roturiers le metier que chaque pere de famille exerçoit," &c. We are informed by Clavigero (*Hist. of Mexico*, B. iv. § 5.), that "the sons in general learned the trades of their fathers, and embraced their professions; thus they perpetuated the arts in families, to the advantage of the state."

Such is the extent to which this institution has existed on the surface of the globe. We shall next endeavour to ascertain the state and condition of the human mind, to which it may be considered as owing its origin.

Origin, and Causes of the Wide Diffusion of this Institution. The lowest and rudest state in which the human race are found to exist, may, in a certain general way, be described as the hunter state. That of the shepherd is the next stage in the progress toward the advantages of civilized life. The agricultural state succeeds; when men begin to cultivate the ground for the means of subsistence, and experience the benefit of fixed habitations.

So long as they continue in the condition of hunters or of shepherds, the division of labour is unknown, and all the multitude of blessings which it brings. Every family is itself the author of all the simple accommodations which it knows. The tent or hovel, the waggon or cart, is constructed by the men; the coarse garment is spun and even woven by the women.

In this situation of things, the accommodations with which it is possible for human beings to supply themselves are few and imperfect; and life is a scene of privation.

When population has so far multiplied as to render the produce of flocks and herds insufficient for the means of subsistence, and the cultivation of the land has become necessary, the inconveniences arising from the want of the division of labour becomes still more sensible and oppressive. The labours of the field are neglected while the family are engaged at the loom, or repelling the incursions of an enemy. The accommodations of lodging, of clothing, of taste, and fancy, are wretchedly supplied, when the business of extracting the means of subsistence from the soil, exacts the greater part of their time and attention.

The progress, however, of human improvement, though not necessarily, is commonly, in point of fact, at least in the more uncultivated ages, exceedingly slow. Men continue to suffer under the inconveniences which their present condition imposes upon them, complaining of their miseries, but unable to form a clear conception of the means of exemption, and doubtful of all the remedies which are pointed out to their attention. In the mean time, as the human mind is essentially progressive, and, unless in very extraordinary circumstances, never fails to make progression, the uneasiness which is felt under the inconveniences of a state to which the mind has become superior, and above which it is rising higher and higher every day, is continually increasing; and at last rises to such a height

VOL. II. PART II.

Caste. that some change is unavoidable; and the society are prepared to welcome the most plausible of the schemes which are proposed to them.

The grand steps which are made in improving the condition of mankind, though essentially the result of a progression in the minds of the society taken as a whole, are commonly the immediate suggestion of some one individual, or small number of individuals, whose conception of the necessity of a change, and of the means of relief, is more clear and determinate than that of the rest of the community.

In the earliest stages, when the human mind is weak and prone to superstition, the individuals who project the great improvements in the state of society, endeavour to accelerate the consent of the people, and overcome their reluctance to innovation, by giving to their projects the character of a divine revelation and command. The first legislators of almost every country, we find to have represented themselves as depositaries of the divine will, and entrusted with a revelation from heaven.

If we take the Hindoos as a model, the people divided into castes with whom our acquaintance is the most complete, we shall conclude, that some individual, wise enough to perceive the cause of the inconveniences under which men suffer while the division of labour is unknown, and placed in circumstances which enabled him to clothe himself with a divine authority, overcame in most places the reluctance of the people to so great a change of their manners and habits, and accelerated the date of their improvement, by persuading them that the divine power, or divine powers, now commanded them to be divided into classes for the performance of certain offices.

In the early stages of society, however, the wants of men are few; and the ideas of the legislator himself are incapable of extending to a great variety of cases. In such periods, the power of superstition is always exceedingly great. Unacquainted with the laws of nature, and exposed to the most dreadful vicissitudes, which they are altogether unable to foresee, human life appears to men in that situation to hang altogether upon invisible powers. The human mind is incessantly occupied with conjectures respecting what those unknown powers will produce, and with tormenting apprehensions that they will produce evil rather than good. The persons who, in this state of things, are skilful enough to create a persuasion that they are better acquainted than others with the will of these powers, more especially if accompanied with a persuasion that they have an influence over that will, and can turn it more or less whichever way they please, become an object of supreme regard. Nothing can be done without them. They are the most important class in the community. When society is first divided into classes, for the sake of the division of labour, the priests, therefore, are always a separate class, and always in the place of highest distinction.

After the evils to which men in the rude state of society conceive themselves liable from the unknown and invisible authors of physical events, the evils to which they are liable from the incursions of hostile men, appear the next in magnitude. While the in-

4 N

Caste.

stitutions of society are imperfect, and the human mind is weak, these evils are very great, and present a terrific picture to an imagination perpetually haunted with fear. In the rude ages of society, therefore, the soldier is always a character of great importance. He is the barrier against those evils which rank next in order after the evils against which the priest affords relief. When classes are first formed, the military are, therefore, always a separate class, and next in rank and veneration to the class of the priests. It is remarkable, that the rank and consequence of both classes are founded upon fear. It is also remarkable, though a natural consequence, that, in all ages, they are most apt to be venerated by the most timid persons,—the most timid sex, for example; over whose imagination the priest and the soldier have a proverbial sway. It is farther observable, and a necessary consequence, that as the fears with respect to invisible powers, and with respect to the incursions of hostile men, gradually decline as society advances, and have less and less effect upon the imaginations even of those who are most apt to be governed by the passion of fear, so the respect for the castes of priest and soldier are destined to sink in relative importance, as the institutions of society are improved, and the human mind becomes strong.

After provision is made, in that early stage of society which we are endeavouring to describe, against the two classes of fears against which the priest and the soldier held up their respective shields, the care of subsistence is the object of greatest importance. A class of husbandmen, therefore, is a necessary and never failing institution, and, in the scale of rank and consequence, this order follows immediately after the sacerdotal and the military castes.

Beside the means of subsistence, other accommodations are required. But, at first, very few are so much as known, and, by consequence, very few are demanded. One class of the community are, therefore, supposed to be sufficient for the supply of all other wants, and the performance of all other services.

It is obvious, that reflection upon the laws of human nature would lead us to draw a picture, nearly the same with this, if we were called upon to describe the state of society, at the time when the division of labour is first introduced, even if we had no specific facts to direct our inquiries. In a remarkable passage in Plato, in his second book *De Republica*, he ascribes the origin of political association and laws, to the benefits which were sought for by the division of labour. *Γρηγορι πωλις, ως εν ὁμοι, σπουδαι, ενχησιν ἕκαστος, εκ αυταρχης, αλλα πολλων οδου.* As men cannot be supplied with accommodations in any tolerable degree, but by the division of labour and employments, one man producing one thing, another another, and every man getting what he wants, by exchange with other men, an association of a certain number of men is necessary for well being; and hence society and laws. In exact coincidence with the deduction which we have presented above, he says, that the simplest form of a society would consist of four or five orders of men. *Αλλα μεν ερηνη ης και μαχητη των χριτων ε της ερηνης τριτων*

κων, δευρατ δε αμνηστος; ερητη σοληρο; και και τριτων. . . . *Επι δε εν ε η ης αμνηστος η τριτων εκ τριτων η και αμνη.* The coincidence is very nearly complete between the speculation and the practice; between what is in this manner inferred, and what is recorded of ancient nations, and witnessed among the Hindus.

Under all the difficulties under which, especially in rude ages, human society; and the human mind, make progress, small are the steps which can be taken at once. When professions were separated, and the vast benefits derived from the separation began to be felt, the human mind was not sufficiently strong to perceive, that there was no danger whatever that they should ever again be combined and confounded. No; it was imagined to be another grand effort of the same wisdom which had made the separation, to take care of its permanence, and to make provision for securing the benefits of it through all ages. With this view it was thought necessary to ordain and sanction, by divine authority, that the son should follow the profession of the father, and be subject to the severest punishment if he engaged in any other occupation. To secure also, in each profession, the due succession of sons to fathers, it was necessary that marriage should be strictly regulated; and the method which obviously enough suggested itself for that purpose was, that the members of each class, male and female, should be compelled, under the severest penalties, to marry only among themselves, and never, by intermarriage, to ruin and confound the separate castes.

So far the aim, at any rate, was good. The benefit of the whole society was the object which all these regulations were accounted useful to promote, and no degradation of any of the classes was either intended by any of these enactments, or necessary for the ends which they were destined to serve.

The degradation of one set of the castes, in comparison with another, was the result of an after-thought, and in the pursuit of ends of a different description. When one of the castes, as that of the priests, or the soldiers, found itself possessed of an influence over the minds of the rest of the community, such, that it could establish certain points of belief in its own favour, it was never long before it availed itself of that advantage, and pushed it to the utmost. If it could inspire the belief that it was more noble, worthy of higher privileges, and greater honour, than the rest of the community, it never failed to get this point established as an incontrovertible right, not the result of the mere will of the community, but of an absolute law of nature, or even a revelation and command from God.

As every elevation of one class implies a correspondent degradation of another, and as there is no end to the elevation which one class will aim at, there is no end to the degradation which will be imposed upon another, if the state of the human mind is sufficiently weak to give to one class an unbounded influence over the belief of another. How naturally this extreme degradation is grafted upon the institution of castes, will immediately appear.

As we derive our most minute and practical acquaintance with the shape into which society is

Caste.
Of the Indian Caste in particular.

moulded by the establishment of castes, ^{from our in-}tercourse with the Hindus, the particulars which are at this day exhibited in Hindustan, and provided for by their laws, afford the most certain means of acquiring precise and specific ideas concerning this remarkable institution.

According to the sacred law book, entitled the "*Ordinances of Menu*," the Creator, "that the human race might be multiplied, caused the Brahmen, the Cahatriya, the Vaisya, and the Sudra (so named from the *Scripture, protection, wealth, and labour*), to proceed from his mouth, his arm, his thigh, and his foot." "For the sake of preserving this universe, the Being, supremely glorious, allotted separate duties to those who sprung respectively from his mouth, his arm, his thigh, and his foot. To Brahmen he assigned the duties of reading the Veda, of teaching it, of sacrificing, of assisting others to sacrifice, of giving alms, if they be rich, and, if indigent, of receiving gifts: To defend the people, to give alms, to sacrifice, to read the Veda, to shun the allurements of sensual gratification, are, in a few words, the duties of a Cahatriya: To keep herds of cattle, to bestow largesses, to sacrifice, to read the scripture, to carry on trade, to lend at interest, and to cultivate land, are prescribed or permitted to a Vaisya: One principal duty the Supreme Ruler assigns to a Sudra, namely, to serve the before-mentioned classes, without depreciating their worth."

Such is the employment of the castes; and such the authority whence it is derived. The next great peculiarity is, the degree of elevation which one set of the castes was enabled to usurp, and the correspondent degradation of the others.

Priests.

1. The Brahmen, or the priests. "Since the Brahmen sprung from the most excellent part," says the same divine code, immediately quoted, "since he was the first born, and since he possesses the Veda, he is, by right, the chief of this whole creation. Him the Being, who exists of himself, produced in the beginning from his own mouth, that, having performed holy rites, he might present clarified butter to the gods, and cakes of rice to the progenitors of mankind for the preservation of this world. What created being then can surpass Him, with whose mouth the gods of the firmament continually feast on clarified butter, and the manes of ancestors on hallowed cakes? Of created things, the most excellent are those which are animated; of the animated, those which subsist by intelligence; of the intelligent, mankind; and of men, the sacerdotal class. When a Brahmen springs to light, he is born above the world, the chief of all creatures. Whatever exists in the universe, is all, in effect, the wealth of the Brahmen; since the Brahmen is entitled to it all by his primogeniture and eminence of birth."

As the Brahman exclusively, or at least to a supreme degree, engrosses the regard and favour of the Deity, so he is entitled to the worship and adoration of mortals. Kings themselves, and the most exalted of men, are infinitely inferior to the meanest of the Brahmen. "Let the king," we again quote the ordinances of Menu, "having risen at early dawn, respectfully attend to Brahmen learned in the three Vedas, &c. . . . and by their decision, let

him abide. Constantly must he show respect to Brahmen, who have grown old, who know the scriptures, who are pure." "The king must appoint seven or eight ministers, &c. . . . To one learned Brahmen, distinguished among them all, let the king impart his momentous counsel. To him, with full confidence, let him entrust all his transactions; and with him, having taken his final resolution; let him begin all his measures." "Let him not, although in the greatest distress, provoke Brahmen to anger, by whom Brahma, the all-devouring fire, was created, the sea with waters not drinkable, and the moon with its wane and increase. What prince would gain wealth by oppressing those, who, if angry, could frame other worlds, and agents of worlds, could give being to new gods and mortals? What men, desirous of life, would injure those by the aid of whom, worlds and gods perpetually subsist; those who are rich in the knowledge of the Veda? A Brahmen, whether learned or ignorant, is a powerful divinity; even as fire, is a powerful divinity, whether consecrated or popular. Thus, though Brahmen employ themselves in all sorts of mean occupations, they must invariably be honoured; for they are something transcendently divine."

The least disrespect to one of the sacred order, is the most atrocious of crimes. "For contumelious language to a Brahmen," says the code of Menu, "a Sudra must have an iron style, ten fingers long, thrust red-hot into his mouth; and for offering to give instruction to priests, hot oil must be poured into his mouth and ears."

The laws give to the Brahmen the most remarkable advantages, over the other classes of the community. Neither the person, nor so much as the property of the Brahmen, can ever be touched, in awarding punishment for the most atrocious crimes. "Never shall the king," says one of the ordinances of Menu, "slay a Brahmen, though convicted of all possible crimes; let him banish the offender from his realm, but with all his property secure, and his body unhurt." This privileged order was entirely exempt from taxes. One of the most important of all duties is to bestow wealth upon the Brahmen, by incessant gifts and donations.

2. The Cahatriyas, or the military caste. Though Military the Brahmen look down upon this class, they are looked up to by all the rest of the classes, with a prostrate veneration, inferior only to that with which the Brahmen are regarded. The difference of rank in India, is not a mere ceremonial distinction. The advantages which are conferred by it, or the injuries endured, are immense; and to the suffering party unspeakably degrading. Any infringement, even of the external marks of the abjectness of the degraded party, is punished as a heinous crime. "If a man of an inferior caste," says Halhed's *Gentoo Code*, "proudly affecting an equality with a person of superior cast, should speak at the same time with him, the magistrate in that case shall punish him to the extent of his abilities." It is unnecessary, under this head, to enter into details, which would occupy a disproportionate space.

3. The Vaisyas, the agricultural and commercial class. It is still less necessary to multiply particular

Caste.

Caste.

Servile
Caste.

lars under this head. When the two extremes are sufficiently explained, what modifications of respect or disrespect belong to the intermediate stages, may be easily inferred.

4. As much as the Brahman is an object of intense veneration; so much is the Sudra an object of contempt, and even of abhorrence, to the other classes of his countrymen. The business of the Sudras is servile labour; and their degradation inhuman. The most abject and grovelling submission is imposed upon them as a religious duty, enforced by the most dreadful punishments. They are so completely deprived of an equal share in the advantages of the social union, that few of those advantages are reserved to them. The classes above them are restrained from injuring them, even in the case of the greatest crimes, by punishments far slighter, than those which are appointed for injuries done to the superior classes. The crimes which they commit, are punished with much heavier inflictions than equal crimes committed by individuals of the classes above them. Neither their persons nor their labour is free. "A man of the servile caste," says the sacred ordinance of Menu, "whether bought or unbought, a Brahman may compel to perform servile duty; because such a man was created by the Self-existent for the purpose of serving Brahmens."

According to the principles of the same code, the Sudra was excluded from the benefits of property. "No collection of wealth must be made by a Sudra, even though he has power, since a servile man who has amassed riches gives pain even to Brahmens." "A Brahman may seize without hesitation, the goods of his Sudra slave; for as that slave can have no property, his master may take his goods."

The degradation of the wretched Sudra extends not only to every thing in this life, but even to religion, and the prospect of future happiness. "Let not a Brahman," says the above code, "give advice, nor what remains from his table, nor clarified butter, of which part has been offered, nor let him give spiritual counsel to such a man, nor inform him of the legal expiation for his sin; surely he who declares the law to a servile man, and he who instructs him in the mode of expiating sin, sinks with that very man into the hell named Asamvrita." Not only are the Sudras not allowed to read any of the sacred books; but, "If," says the *Gentoo Code*, "a man of the Soeder reads the Beids of the Shaster, or the Pooran, to a Brahman, a Chehteree, or a Bice" (Halhed's mode of spelling the names of the four castes), "then the magistrate shall heat some bitter oil, and pour it into the aforesaid Soeder's mouth; and if a Soeder listens to the Beids of the Shaster, then the oil, heated as before, shall be poured into his ears, and arzeez and wax shall be melted together, and the orifice of his ears shall be stopped up therewith. If a Soeder gets by heart the Beids of the Shaster, the magistrate shall put him to death. If a Soeder gives much and frequent molestation to a Brahman, the magistrate shall put him to death." From this specimen of particulars, a judgment may be formed with regard to the rest.

Though this is the primary and original formation

of castes, the institution, unless where it happens to be early broken up, does not rest here. The distribution of the members of the community into four classes only, and the appropriation of their services to four species of employment, though a great step in improvement at the time they were instituted, must have become productive of many inconveniences, as the wants of society multiplied. The necessities of life, with a few of its rudest accommodations, are all the means of gratification which it affords, or is capable of affording to mankind. As the desires of mankind, however, speedily extend beyond such narrow limits, a struggle must have early ensued between the first principles of human nature, and those of the political establishment.

And this was not the only evil to which, under this primary institution, society was exposed. The different castes were strictly commanded to marry with those exclusively of their own class and profession; and the mixture of the classes by the union of the sexes, was guarded against by the most sanguinary laws. This, however, was a result which laws were not sufficiently powerful to prevent. Irregularities occurred, and children were born who belonged to no caste, and for whom there was no occupation. A more calamitous event could not fall upon human society. Unholy and infamous on account of that violation of the sacred law to which they owed their unwelcome birth, those wretched outcasts had no resource for subsistence, except two; either the bounty of the regular classes, to whom they were objects of contempt and abhorrence, not of sympathy, or the plunder of those classes by whom they were oppressed; a resource to which they would betake themselves with all the ingenuity of necessitous, and all the ferocity of injured men.

When a class of this description became numerous, they must have filled society with the greatest disorders. The nature of the case would have drawn the philosophical mind to this conclusion, had no testimony existed. It so happens, however, that this is one of the few facts in the ancient history of the Hindus, which can be ascertained from their records. In the preface to that compilation of the *Hindu Law*, which was translated by Mr Halhed, it is stated that, after a succession of good kings who secured obedience to the laws, and under whom the people enjoyed felicity, came a monarch, evil and corrupt, under whom the laws were violated, the mixture of the classes was perpetrated, and a new and impious race were produced. The Brahmens put this wicked king to death; and, by an effect of miraculous power, created a successor, endowed with the most excellent qualities. Nevertheless the kingdom did not prosper, by reason of the Burren Sunker (so were the impure and irregular brood denominated); and it required all the wisdom of this sage and virtuous king to devise a remedy. He resolved to form a classification of the mixed race; and to assign them occupations. This accordingly was the commencement of arts and manufactures. The Burren Sunker became all manner of artisans and handicrafts. Of the classes into which they were distributed, one was appointed to the weaving of cloth, another to works in iron, and so in all other cases;

Caste. till the subdivisions of the race were exhausted, and the wants of the community were provided for. Among the Hindus, thirty-six castes of the impure race are enumerated, all inferior in rank and privileges even to the Sudra. To proceed farther in the detail, would be inconvenient and useless. By this supplement to the institution of the four primary castes, two great evils were remedied at once; the increasing wants of an improving society were supplied, and a class of men, who had been the pest of the community, were converted to its service.

The only remaining inquiry with respect to the institution of castes, which seems appropriate to this place, is that of its utility or inutility as a part of the social establishment.

A few words, we think, will suffice, to convey clear and determinate ideas upon this subject.

General View of the Effects of this Institution. It is the distinction of man's nature, that he is a progressive being. It is by this grand characteristic that he is separated so widely from the inferior animals. When found in circumstances and situations in which the benefits of progression seem not to have been reaped, he is raised but a slight degree above the condition of some of the more perfect of the inferior animals. His peculiarity is, that he is susceptible of progression; and unless when he is placed in circumstances which impose extraordinary restraints upon the principles of his nature, does invariably and incessantly make progress. Even when he originates in a state little above that of the inferior animals, he rises, and gradually ascends from one stage to another, till his elevation above all the other inhabitants of this globe is immense; nor is there any limit which our knowledge permits us to set, to his final attainments and felicity. In whatever state the other animals originate, in that same state they remain through all ages; and seem altogether incapable of improvement.

In regard to man, therefore, considered as a class of beings, or an order of existence; every thing is to be considered as beneficently important, in proportion as it favours his progression; every thing is to be considered as mischievously important, in proportion as it obstructs and impedes that progression.

It is by this grand test of all that is good and evil in human institutions, that we shall endeavour to estimate the effects of the establishment of castes.

We shall not here adduce the elevation of one set of the classes, and the correspondent degradation of another, obviously the cause of infinite evil; because it may be with justice maintained, that this horrid elevation, and equally horrid depression, are not essential parts of the institution of caste, but arise from other causes, and may, in fact, be separated from that institution.

First of all, it is evident, that at the time when the number of castes and professions is established, unless it could be foreseen what are all the species of operations or arts, by which the desires of man, in all their possible varieties, are capable of being gratified; and what are all the possible divisions of labour from which any good can arise; the appointment of fixed, unalterable castes and professions, must oppose an irresistible barrier to human advancement in these two grand instruments of progression, the divi-

Caste. sion of labour, and the practice of new arts, as invention may suggest them, or the multiplying desires of an improving society may create the demand. Since it is obviously impossible that all these things can be foreseen, it is abundantly certain, that the institution of any fixed number of arts and trades is exactly an institution for preventing the progression of mankind. This deduction appears to be conclusive; and, if there were no other argument, affords a complete answer to the question respecting the utility of castes.

Even in the trades and arts which are known and provided for at the time of the institution, it is by no means certain, that this fixed order of the persons who are to practise them is a contrivance well adapted for carrying these arts themselves, whether large in number or small, to their highest state of perfection. It by no means follows, that a man will do any thing better than any other man because his father did it before him. To establish a caste for any particular art or profession, is giving a sort of monopoly to that particular description of men. It is a wide monopoly, to be sure; but as far as the appropriation of the art to one class is calculated to have any effects, they must so far be such as it is of the nature of a monopoly to produce, and hence unfavourable to the progress of the art. The way which presents itself to the reasoning mind, as that which is best calculated for improving every branch of human industry or skill, is to open, as widely as possible, the doors to competition; not to exclude any man, of whatever origin, who may appear to have an extraordinary genius for any particular thing, but allow him, through competition, to reap the reward of his superiority, and hence to feel all the motives that can prompt him to excel. The acquirements of one generation are not transmitted to another more surely when they are transmitted from father to son, than when they are transmitted in the way of promiscuous instruction. Nor does it necessarily, or even commonly, happen, that the learner gets more careful instruction from his father, than he would from a man who is not his father; or, that he himself is more intent in his application, and careful to learn, because it is his father who instructs him.

In the sciences and the fine arts, the power of excelling in which depends upon rare combinations of circumstances, to limit the number of competitors, and shut up the field from all but the members of a particular tribe, is obviously a powerful expedient for diminishing the chance of progression. In regard to literature and knowledge the case is clear and decisive. To confine the prosecution of it to a particular tribe, is to insure a perpetuity of ignorance and misery to the human race. It will be decidedly the interest of the knowing class to maintain as much ignorance as possible among the rest of the community, that they may be able the more easily to turn and wind them conformable to their own purposes; and, for that end, to study, not real knowledge, not the means of making mankind wiser and happier, but the means of deluding and imposing upon them; the arts of imposture. With this clear and incontrovertible inference, how exactly does the historical fact cor-

Caste.

respond? How truly and faithfully have the Brahmens acted up to that rule? They have made it a law revealed from heaven to keep the great bulk of the community in ignorance. And what branch of knowledge have they ever studied but the science of delusion? There is first their theology; a mass of absurd fictions to chain the imagination of ignorant and foolish men. And then there is astrology, which concludes the circle of all their studies, and may be justly styled the "Second Part of the Act of Imposture;" even their mathematics, in which they made some little progress, being studied in no other shape than as a part of the business of astrology.

Another circumstance appears to merit no slight regard. The institution of castes is calculated to multiply the evils, so dreadful in magnitude, which are apt to arise from the principles of population, and is opposed to the measures which are calculated to lessen or prevent them. The evils which are apt to be produced by an occasional superabundance of people in any one of the departments of industry and subsistence, are exceedingly diminished, when the greatest possible facility is given to the supernumerary individuals, of distributing themselves through all the other departments of industry and subsistence. And these evils, it is obvious, are all raised to the greatest height when the possibility of that distribution is taken away; and individuals, in whatsoever degree superabundant, are still confined to their own department. As this is a topic, the elucidation of which is easy to carry on; we shall content ourselves with the bare hint which has thus been given, and leave the developement to the reflections of the reader.

It may be added, as a supplement to what was said about the obstruction which, by the institution of castes, is given to progression, not only in the division of labour and the multiplication of arts, but even in perfecting the arts which are known and practised, that the strict confinement of one tribe of men to one tribe of operations must have a strong tendency to create a habit of routine, and hence an aversion to all innovation; a disposition to acquiesce in what has constantly been done, as if it were that which ought to be constantly done; and hence to deaden that activity of mind which is on the alert to catch at every chance of improvement,—that admirable temper, on which the greatest rapidity in the march of human amelioration essentially depends.

It was intended, after thus presenting the reasons on which we conclude that the institution of castes is an arrangement altogether opposite to the interests of human nature, to have stated and answered the reasons which have been advanced by Dr Robertson, in the *Appendix to his Historical Disquisition Concerning India*, and very recently by the Abbé Du Bois, in his *Description of the Character, &c. of the People of India*, to prove that the institution of castes is really beneficial. But after looking over these reasonings, with a view to that answer, they have appeared to us to be so weak and insignificant, as to be altogether unworthy the trouble of transcription. A sufficient answer to every point which they adduce,

will be found in the considerations which we have already urged upon the subject; and we doubt not, that we may safely intrust the decision to the judgment of the reader. Caste
Casi

(F. F.)

CASTI (GIAMBATTISTA), an Italian Poet, was born of humble parents, in the year 1721, at Montefiascone, a small town in the States of the Church. It was there, too, that his studies commenced, in which he made such rapid progress, that he was appointed, in early youth, Professor of Greek and Latin, in an academy of his native town,—an employment which peculiarly directed his attention to Classical Poetry and Literature. He soon, however, quitted this obscure situation, and repaired to Rome, in search of more noble examples of emulation, and a higher recompense of public esteem than his birth-place afforded him. His learning, acuteness, and agreeable disposition, recommended him to the notice and friendship of the most eminent individuals of that capital. He was admitted a Member of the Academy *Degli Arcadi*, and it is believed he might easily have risen from a Canonship in the Cathedral of Montefiascone, which he had already obtained, to the enjoyment of much higher church benefices, had such been the chief objects of his ambition. But his love of freedom, and his restless inclination for travelling (which appears to have been characteristic of all the literary men of Italy), interfered with his ecclesiastical preferment. He gladly accepted the invitation of Prince Rosenberg (tutor to the Grand Duke Leopold), with whom he had become acquainted at Florence, to accompany him to Vienna, where he was presented to the Emperor Joseph. After this introduction, he visited almost all the capitals of Europe, from Petersburg to Lisbon, and from Constantinople to Stockholm, directing his particular attention to the manners and civil institutions of the various countries through which he passed. On his return to Vienna, he was appointed *Poeta Cæsario*, or Poet-Laureate, in the room of Metastasio, a situation which he held till some time after the death of the Emperor Leopold, when he resigned it, and retired to Florence in 1796. During two years residence in that city, he composed a great number of his works. At the end of that period, he went to live in Paris; and, though now far advanced in life, neither his habitual gaiety nor ardour of literary composition were in any degree abated. Scarce a day passed in which he did not add something to his principal poem, *Gli Animali Parlanti*, or write one of his poetical novels. At the same time, he delighted the society with which he lived by the unceasing liveliness of his conversation, which was rendered highly entertaining and interesting, by his knowledge of the world, and the extensive opportunities he had possessed of observing the manners and characters of mankind. Though, in 1808, he had passed the age of 82, the strength both of his mind and body still afforded the promise of a yet longer life; but he died during this year, in consequence of having caught a severe cold, in returning home at a late hour from a house where he had spent the evening. His funeral was attended by a great concourse of French and Italians, distin-

Casti.

guided by literary eminence, and an eloquent funeral oration was pronounced on this occasion by Corona, an Italian physician.

The chief work of Casti is *Gli Animali Parlanti*, poema Epico Diviso, in XXVI. Canti. In 1792 and 1793, the French revolution had attracted the attention and speculations of all Europe, and had introduced comparisons between new theories of government and ancient institutions. The rage of innovation, and dislike of established forms, having infected the minds of so large a proportion of the community, Casti resolved to exhibit, though under an allegorical veil, what he conceived to be the predominant feelings of the multitude, their avowed hopes, and secret designs. With this view, as he himself has expressed it in his preface, "he contrived a grand apologue, divided into parts, and forming a continued poem, in which animals being introduced as speakers and actors, a complete political story might be exhibited, exposing the defects of various political systems, and the absurdity of many institutions which had been from time to time adopted." Near the commencement of this apologue, the beasts assemble to choose a king, and after a good deal of intrigue, and various harangues, the lion is elected. On his death, the folly of the lioness regent, and perversity of the royal cub, excite murmurs, cabals, and at length a successful insurrection, which is headed by the dog. By thus assigning to animals human speech and passions, the author has very happily parodied the usual appearances and events of political revolutions in general; but often with some allusion to the political events of the day, to the characters of the reigning princes of Europe, and to that most portentous of all revolutions, the consequences of which at that time occupied so large a portion of the thoughts of mankind.

Accordingly, we find that in this work, Casti has portrayed and satirized the hypocrisy so often mixed in political pretensions—the secret ambition of leaders, who alternately supplant and succeed each other—the intolerance of cabals and parties, who proscribe all who have not ranged themselves under their banners, and who regard the maxims which happen to be then in vogue as fixed and immutable principles. He has represented, with peculiar felicity, the democratic declamations of the dog, once so loyal, the aristocratic surliness of the bear, the simple good-nature of Lion I. and the caprices of his cub Lion II. who is obviously intended for the late Czar of Muscovy. It must, however, be confessed, that the pleasantry of an apologue of twenty-six cantos, each of about 600 lines, is too much prolonged, and the too frequent negligence of the style, with the repetition of trivial and obvious morals, like those at the bottom of the page in the English *Æsop's Fables*, do not aid in sustaining the curiosity or interest.

This work of Casti, which raised him to a very high rank among the modern poets of his country, was begun at Vienna in 1794. His situation, however, as poet-laureate, was unfavourable to the freedom of political satire, and this obstacle to his favourite pursuit may have been one inducement to his resignation of that office. After his retirement,

Casti.

the poem was continued at Florence without interruption, and completed at Paris, where it was published in 1802, in 3 vols. 8vo, an impression which has been followed by various editions in Italy. It was translated into French, Spanish, and German, and we have also seen a free and abridged English version, executed with considerable vivacity and spirit. To most of the Italian editions, four apologues have been added, but which have no relation to the subject of the *Animali Parlanti*. One of them, entitled *Della Gatta e del Topo*, written, we believe, before the author was poet-laureate, and published certainly after he had resigned that situation, is supposed to pourtray those sinister events which clouded the prospects of aggrandizement anticipated by Joseph from his formidable league with Russia against the Turks.

Casti having completed his great work of the *Animali Parlanti*, anew directed his attention to the composition and publication of poetical novels. As far back as the year 1778, he had written eighteen of these *Novelle Galanti*, but his poetical avocations at the Imperial Court had interrupted his progress; and meanwhile those he had composed were surreptitiously printed, both in Italy and France, in a manner so inaccurate, and so much altered from the way in which they had been originally written, that they could scarcely be recognised by the author, as we learn from the *Protesta dell'Autore*.

"Molti vi son che senza mio permesso
Sparser le mie novelle, e v'han cangiato
Ordine, senso, e turri, e stoffe; e spesso
Mi fan dir ciò che non ho mai pensato,
Che appena omai mi vi conosco io stesso."

Some too, as *La Bella Circassa*, and *La Figliu che non ha Giudizio*, which were not written by Casti, were added to these surreptitious publications:

"Saran belli e leggiadre poesie,
Tutto quel che vi vuol; ma non son mie."

In these circumstances, the injured poet assiduously prepared himself to enlarge the number of his novels, and to collect the whole in an edition which might be printed under his own immediate superintendence. He was prevented, however, by his sudden death; but his novels, which, at the period of his decease, amounted to forty-eight, were published by one of his Parisian friends, in 3 vols. 8vo, 1804, accompanied by a prefatory memoir of the author. The practice of tale-writing, which commenced with the author of the *Cento Novelle Antiche*, and was brought to such perfection by Boccaccio, had prevailed in Italy for nearly 500 years before the age of Casti. The Italian novelists invariably copied from each other, and from those inexhaustible stores of fiction, the *Fabliaux* of the Trouveurs. But the merit of Casti does not consist in the invention of his stories, all of which are borrowed, but in being the first among his countrymen who has clothed these tales in a poetical garb. His Novels are founded either on mythological stories, or on preceding Italian tales. To the first class belong *Aurora*, *L'Origine di Roma*, *Diana ed Endimione*, *Prometeo e Pandora*. Almost all the rest are poetical versions

Casti.

from Boccaccio, Massuccio di Salerno, and other Italian novelists. The longest, *La Papessa*, which is divided into three parts, is founded on the old story of Pope Joan. These tales are much admired by the Italians for purity of language, and harmony of versification, and they contain many ingenious and sarcastic reflections on the hypocrisy, errors, and vices of men in every age and condition of life. They are disfigured, however, by an unpardonable licentiousness, which is carried much farther than that of almost any of the prior novelists of Italy. Some of them also terminate rather flatly, and the octave stanza, in which they are all written, and which has a certain degree of heaviness, even in the hands of Ariosto and Berni, is ill adapted to the gaiety and levity of the lightest of all species of composition. One cannot mention the tales of Casti without being naturally led to compare them with those of Fontaine, which are founded on similar originals, and written in something of the same spirit. But, if there be more asperity and caustic raillery in Casti, he is infinitely inferior to the French poet in ease, *naïveté*, and grace. The language in which he was obliged to write, whatever may be its other excellencies, is less expressive of playfulness than the French, and the octave stanza, which he unfortunately chose, is not susceptible of the buoyancy and lightness of Fontaine's versification.

The *Animali Parlanti*, and the *Novelle* are the best known and most popular works of Casti; but he is also author of the *Poema Tartaro*, a satiric poem, in twelve cantos, on the Court of Catherine II. The scene of action, however, is laid in Asia, and all the names are fictitious. Russia is called Mogollia—St Petersburg, Caracora—The Empress, Cattuna—the Grand Duke Paul, afterwards Czar, Cajuco—Orloff, Cuslucco—and Potemkin, Toto Toctabei. The first sketch of this mock-heroic poem was made by the author during his visit to St Petersburg, in the train of Count Kaunitz, the Austrian Ambassador. On his return to Vienna, the Emperor Joseph having manifested a desire to hear it read, Casti new-modelled the composition, struck out whatever might be likely to prove offensive to crowned heads in general, and inserted a complimentary episode on the celebrated journey of his imperial patron into the Crimea. Notwithstanding the approbation which his poem met with from the Austrian court, Casti would not probably have published it during the life of the heroine; but numerous manuscripts of it having been circulated, some of them found their way to Italy, where it was repeatedly but very incorrectly printed, none of the impressions having been ever subjected to the revision of the author.

In his capacity of poet-laureate, it was the duty of Casti to provide new dramatic entertainments at stated occasions and periods. The court and public of Vienna had probably grown weary, in the course of half a century, of the elegant moral monotony of Metastasio; and Casti, whose genius was diametrically opposite to that of his predecessor, could not have vied with him in the grand or serious opera. He therefore resolved to excite the mirth of the spectators by the revival of the *Opera Buffa*, in which he

obtained great success. One of his productions in this line, entitled *La Grotta di Trofonio*, is intended to ridicule the pretensions of false philosophers. The subject of another, *Il Re Teodoro in Venezia*, suggested by an episode in Voltaire's *Candide*, was assigned to him by the Emperor himself, who is said to have been much entertained with the lines

*Senza soldi e senza regno
Brutta cosa è l'esser Re.*

A third burlesque opera, of which Cicero is the principal character, is founded on the plot of Catiline. Here the characters of the Roman senators and conspirators, with the orations against Catiline, are so parodied as to produce something of the same effect as our mock tragedies, or the ancient satiric drama of the Greeks.

On the whole, although neither the Novel nor the Apologue was by any means a new species of composition among the Italians, yet Casti may be regarded an original author, in so far as he has bestowed a new form on the first, and has given to the second an extent which it had not yet received, as well as directed it to an object to which it had not been previously applied. (M.)

CATOPTRICS. See the *Encyclopædia* under that head, and OPTICS in this *Supplement*.

CAUBUL. That extensive territory in the centre of Asia, which at present composes the kingdom of Caubul, is formed of various and disunited portions. The basis is a large tract of mountain table land, interposed between Persia and Indostan, and to which the Persians have given the generally received appellation of Afghaunistaun. To this original territory, conquest has added, on the east, Cashmeer, with the greater part of Moultaun and Lahore, called commonly the Punjaub; on the north, Bulkh, or Bactria; on the west, Herat and a great part of Khorasan; and, on the south, a portion of Sinde and Beloochistaun. Several of these provinces are very slightly attached to the main body of the kingdom. Beloochistaun and Bulkh have been already described; and the provinces of Moultaun and the Punjaub are so connected with Indostan by natural boundaries and physical aspect, that we cannot forbear referring them to that country, notwithstanding the political events which, at present, sever them from it. Our details will refer chiefly to the remaining provinces, which may be considered as the integral portions of the kingdom of Caubul. Under the heads of AFGHANS, CAUBUL, and CANDAHAR, in the original work, will be found a summary of the very little that was known relative to this part of Asia. Mr Elphinstone's excellent account of his recent mission to Caubul, has thrown an entirely new light upon those regions; and will enable us to exhibit a much more full and satisfactory view, than was before possible, of their actual condition.

The modern Afghaunistaun was recognised by the ancients under the appellations of Aria, Draugiana, Arachosia, and Parapomius; but these countries were scarcely known, unless by the marches of Alexander, who traversed them only partially; for, in advancing, he went chiefly to the north of this region, and to the south of it in returning. In modern times, Cau-

Caubul. bul has shared all the revolutions which has changed the face of Southern Asia. In the eleventh century, under Mahmood of Ghuznee, it was the seat of an Empire, which extended from the Ganges to the Euphrates, and from the Jaxartes to the ocean. This sceptre was broken by the inroad of those innumerable hordes which, under Gengis and Timour, poured down from the interior of Tartary. Caubul was conquered, in 1506, by the Emperor Bauher, who made the city of that name his capital. This example was not followed by the Moguls and his successors; but the plains of Afghaunistaun continued to be divided between Persia and India, while the mountainous tracts commonly maintained their independence. In the beginning of the last century, a tribe of Afghauns conquered Persia, and continued to reign over that Empire till its independence was re-asserted by Naudir Shauh. That daring Chief not only expelled the invaders, but rendered Caubul, in its turn, subject to Persia, and carried his arms into Indostan. After the death of Naudir, Ahmed Shauh, the head of one of the principal Afghaun tribes, founded the present kingdom of Caubul. He not only made it independent of every foreign power, but extended its boundaries on every side, twice entered Delhi, and annexed to his dominion several of the Indian provinces. In 1773, he was succeeded by his son Timour, a moderate Prince, who made it his chief aim to maintain tranquillity throughout his extensive dominions. In this object he with difficulty succeeded; but a train of policy, so adverse to the habits and inclination of his subjects, was not calculated to make his government respected, and he left, in 1793, a weakened sceptre to his posterity. In this kingdom, the Chiefs select from the sons of the deceased monarch the individual whom they judge best qualified to reign. The choice, in this instance, fell upon Zemaun Shauh. A half-brother, Mahmood, however, raised the standard of revolt, and, after various successes, obtained possession of the person of Zemaun, whom he deposed, and deprived of sight. Meantime another brother, Shujah, advanced a claim to the throne, which he made good, and was found reigning at Peshawer when Mr Elphinstone arrived there in 1808. Mahmood, however, had escaped from prison, had raised a new force, with which he had taken Candahar, and was advancing upon Peshawer. The mission afterwards learned that he had entered that city, driving Shujah before him. A civil war then ensued, in which the contending parties alternately obtained possession of the capital. Which of the two now holds the preeminence is not known, and is not of very much importance; but it is of importance to ascertain the general statistical and political state of a great kingdom, which borders so closely on our eastern possessions.

Boundaries. The kingdom of Caubul is bounded on the east by Indostan, on the north by Toorkistaun, or Independent Tartary, on the west and south by Persia. Its extent may be roughly stated at 600 miles from east to west, and 550 from north to south.

Mountains. Among the natural features of Caubul, the most remarkable is that portion of the great mountain chain of Asia, which passes along its northern front-

Caubul. tier. The lofty peak of Hindoo Coosh or Koh, communicates its name to this range, which forms evidently a prolongation of the Hemalleh, or snowy chain, which divides India from the table land of Thibet. Hemalleh, however, extends from south-east to north-west, while Hindoo Coosh runs directly east and west. It is of stupendous height, and its most elevated summits clad in perpetual snow; yet they do not seem altogether to equal some of those which tower above the plains of Nepaul. The observations made by Lieutenant Macartney, apparently with considerable skill and attention, fixed the elevation of some peaks at 20,493 feet; though the operation, being performed at the distance of 100 miles, afforded too small an angle to secure rigorous accuracy. "The stupendous height of these mountains; the magnificence and variety of their lofty summits; the various nations by whom they are seen, and who seem to be brought together by this common object; and the awful and undisturbed solitude, which reigns amid their eternal snows, fill the mind with admiration and astonishment, that no language can express." This chain continues with undiminished magnitude for about 440 geographic miles west from Cashmeer, and then shoots into that elevated peak to which the name of Hindoo Coosh is peculiarly applied. West of this point, it becomes considerably lower; and travellers from Candahar to Bulkh cross it without meeting any perpetual snow. The Greek term of *Parapomius* is here commonly applied to it. In approaching the frontier of Persia, the mountains become of still inferior elevation; though branches continue to stretch westward, which may be viewed as prolongations of the great central chain.

Next in magnitude to the Hindoo Coosh, ranks the ridge of Solimaun. It commences a little to the west of Peshawer, at a very high peak, covered with perpetual snow, called Suffaid Koh, and proceeds thence, with diminishing magnitude, almost directly south, till it sinks into the plains of Sinde and Beloochistan. Only a narrow valley, through which the Caubul river flows, is interposed between it and the central range, on the opposite side of which begins the Beloor Taugh, extending northward as far as Cashgar, and which may probably be considered as a continuation of the Solimaun. From these two principal ranges, a variety of others, in different directions, traverse the elevated plain of Afghaunistan. One of the most remarkable of these is the Salt range, which, beginning not far from Suffaid Koh, runs east-south-east, crosses the Indus at Karrabah, or Callabaugh, and is continued to the banks of the Jelum. It is composed in many places of solid salt, clear as crystal, and so hard that plates for the table are formed out of it. At Callabaugh, it is seen lying in large blocks, for the purpose of being conveyed to the countries situated up and down the river. In other respects, the mineralogical structure and composition of all these ranges is entirely unknown.

Of the rivers of the kingdom of Caubul, the most considerable by far is the Indus. This stream has been proved, by recent discoveries, to have a much longer course than had hitherto been assigned to it

Caubul. by modern geography. It seems to have been traced to a mountainous track on the eastern border of Little Thibet, the same which, on its opposite side, gives rise to the Bramapoutra. Here two branches arise, near to each other, which, after widely diverging, unite a few journeys to the north-east of Cashmeer. Soon after their combined streams turn to the south, and force their way across the barrier of Hindoo Coosh. Here the Indus is, for a long time, confined in a narrow channel between rocks, and after receiving the rapid river of Caubul, is broken into numerous whirlpools and eddies, which are heard to a great distance, producing a sound like that of a stormy sea. After passing the salt range at Callabaugh, the stream no longer meets with any obstruction, and pours its waters over the plain in various channels, which successively separate and reunite, till they are poured, by many mouths, into the Indian Ocean. Near Auch an important accession is received from the Punjnd, which bears the united waters of the five great rivers that traverse the Punjaub; yet all these combined are considerably inferior to the Indus before the junction. The whole course of this noble river is estimated at 1350 miles.

Among the rivers which fall into the Indus from the west, the principal is the Kama, which, rising on the opposite side of the same peak which gives rise to the Oxus, rolls through the mountainous country of Kaushkaur, then penetrates the barrier of Hindoo Coosh, and pours down with tempestuous rapidity into the valley beneath. It here joins the river of Caubul, and the united stream falls into the Indus a little above Attok. The western part of Afghaunistaun is watered by the Helmund, which rises near Caubul, and, after rolling for 200 miles through mountainous tracks, enters a fertile plain, which, however, is soon crossed, and its subsequent course directed through a desert, when it falls, beyond the Afgham frontier, into the lake of Durra or Zereng. Its whole length is about 400 miles. It receives a considerable number of smaller streams from different parts of the chain of Parapomusis. Near Ghuznee several small streams concur in forming the only lake in this country, called Aubiastandeh.

Climate and Seasons.

The climate of Afghaunistaun exhibits the most striking varieties, in consequence of the abruptness with which the mountain ranges often rise from the deep plains beneath. A few hours journey carries the traveller from a place where snow never falls, to another where it never melts. In the plain of Jellalabad, immediately beneath Suffaid Koh, persons are often killed by the intensity of the hot wind, while regions of eternal ice are towering above. At Caubul, the winter, if not more severe, is more steady than in England. The inhabitants wear woollen cloths and great coats of tanned sheep skin; they often sleep round stones, and avoid, as much as possible, leaving the house till the vernal equinox brings milder weather. Ghuznee, from its high situation, suffers more from cold than any of the other cities; and snow there often lies deep after the vernal equinox. In Damaun, on the contrary, a province lying along the Indus, the heat is such that the inhabitants are obliged to wet their clothes before going

to sleep, and to keep, during the whole night, a vessel with water standing by the bedside. The heat is still more intense in the plain of Sewcestaun, on the south western frontier; whence the Afghans are accustomed to make the odd exclamation, "O Lord, when thou hadst Sewee, why needest thou to have made Hell!"

The prevailing winds in Afghaunistaun are from the west and south-west. The latter begins in the middle of summer, and blows for about a hundred and twenty days without intermission. This wind, throughout all this country, is cool, while the east wind is hot. The chief rain is in winter. When this falls in the form of snow and melts at the return of heat, it is of great importance to agriculture; but in the form of rain, its effect is lost, and the main dependence of the husbandman is then upon another rain, much smaller in quantity, which falls in spring. The monsoon that produces the great rains of India, is scarcely felt in Afghaunistaun; and the latter may be considered in general as a dry country.

The soil is nearly as various as the climate. In well watered plains of moderate elevation, as Peshawer and Candahar, it is exceedingly fertile, and produces two full crops in the year. Wheat and barley, the grains of Europe, are cultivated in preference to rice and Indian corn. In the higher districts, only one crop can be raised in the year; and in some, the grain must be sown at the end of one autumn, that it may ripen before another. The loftier part of the mountain chains is of course condemned to perpetual ruggedness and sterility. On the other hand, in the level districts to the south, bordering upon Seestaun and Beloochistaun, extensive deserts are produced by the absence of water. The empire of desolation seems, on this side, to be continually spreading; the moving sand being blown by the south-west wind over the bordering fertile tracts, which it gradually covers, and converts into desert.

The account of the animals of Afghaunistaun is very imperfect. Lions are rare; tygers and leopards are more common; wolves, hyenas, foxes, and hares, everywhere abound. The agricultural labour is performed by oxen; but a species of broad-tailed sheep form the riches of the pastoral tribes. Horses occur in considerable numbers, but not of the same excellent quality as those bred in the extensive plains north of Hindoo Coosh.

The political constitution of Caubul is by no means of that simple structure which is usual in Asiatic monarchies. The royal power has been compared to that which was exercised by the Scottish monarchs during the feudal ages. Over the great towns, the country in their immediate vicinity, and the foreign dependencies, their authority is direct, and almost supreme. The rest of the nation is divided into clans or communities, who act nearly independently of the sovereign, and from whom a contingent of troops and money is with difficulty levied. These communities are called Oolooos. They are governed by a Khaun, who is usually appointed by the King, but always out of the oldest family of the Oolooos. The Khaun, within his own community, is quite a limited monarch; he can undertake no-

Caubul. thing of importance without the consent of the Jeerga, or representative assembly of the people. The judicial power, so far as exercised, is also vested in the Jeerga. The principle of private revenge, however, is deeply rooted in the mind of the nation, and an appeal to the Jeerga carries with it some degree of reproach; being supposed to indicate, in the individual who has recourse to such a remedy, a want either of power or courage to vindicate his own wrongs. Even the Jeerga recognises the right of retaliation, by making a formal offer to the offended party of delivering the criminal into his hands, that he may inflict his own punishment, though it is understood that he shall decline and leave the point to the determination of the Jeerga. Alliances are formed, and wars carried on by the Oolooos between themselves, without any concern or interference of the sovereign. This form of government keeps every part of the country in a state of tumult and ferment, and presents at first sight a very unfavourable contrast to that undisturbed tranquillity which, under an absolute government, reigns over the greater part of the plains of India. Mr Elphinstone, however, through this outward aspect of rudeness and turbulence, saw enough to convince him of the radical superiority even of this rude freedom. The powers of action, and, as it were, of vitality, lodged in each of these independent communities, enabled it to flourish, unaffected by the personal character of the sovereign, or even by the convulsions which subverted his throne. The succession of revolutions to which the kingdom has been exposed during the last half century, have produced effects visibly injurious on the great cities, and the districts situated along the high roads. But the more remote and independent parts of the country have proceeded in an uninterrupted career of improvement; cultivation has been extended, new aqueducts built, and various public establishments undertaken.

National
Character
and Man-
ners.

Though the external appearance of the Afghans be more uncouth than that of the Indians, they possess estimable qualities to which he is a stranger. A certain measure of reliance can be placed upon their statements of fact; not that they can compare with Europeans in veracity, or will scruple dissimulation, when any great interest is to be promoted; but they are far from that profound and habitual falsehood, which characterizes the natives of Persia and Indostan. They manifest also an active spirit of curiosity, to which the subjects of despotism are altogether strangers. Displays of European art and machinery, which by Indians were noticed evidently from mere politeness, without any real interest, excited in the Afghans the highest gratification, and an anxious wish to examine the processes by which they were performed. There exists also more purity of manners than is observed in other Asiatic countries. Polygamy, indeed, and the purchase of wives, prevails here, as over all the East. They are well treated, however, and often acquire an ascendancy in the family, from which the severity of Mahometan institutions seems elsewhere to exclude them. In the country districts, where the system of seclusion cannot be carried to such a rigorous extent as in towns, the passion of love seems often to be felt

Caubul. in all its ardour. Many of their popular poems relate to amorous adventures, and detail incidents not dissimilar to those which form the subject of similar compositions in Europe. It is said to be not uncommon for a young man to set out for India, or some other foreign country, with a view of earning the purchase money of the female of whom he has become enamoured. This price being usually considerable, the procuring of an Afghau wife is attended with difficulty, and men arrive often at the age of forty, before they are able to collect a sum sufficient. This has led to a very peculiar mode of penal infliction. The fine imposed, on conviction of any crime, is levied in young women, to be given as wives to the injured person or his friends. Murder is twelve young women; severe mutilation, six; and so on, diminishing for smaller offences.

Hospitality is a virtue for which the nation is eminently distinguished. Not only a stranger, but the bitterest enemy, beneath the roof of an Afghau, is in perfect security. Usage has even established, that any individual, who enters his house, and places himself in the posture of a supplicant, shall receive the boon which he thus craves. Yet, with this even romantic courtesy and humanity, are combined almost universally the habits of plunder and robbery. The extent of these practices varies among different tribes; and in those placed under the immediate eye of the Sovereign they are much restrained; but scarcely any tribes are wholly exempted. Instances have occurred in which an Afghau has received a stranger with all the rights of hospitality, and afterwards, meeting him in the open country, has robbed him. The same person, it is supposed, who would plunder a cloak from a traveller who had one, would give a cloak to one who had none. From these circumstances, it is conceived, that no European, carrying property along with him, could, with any degree of safety, travel through Afghauistan. Nothing except absolute poverty could afford him any chance of security.

The Afghau nobles reside almost entirely at court. They maintain a considerable state; but do not move with that crowded and noisy attendance which forms the delight of the Indian great man. In their comparatively small retinue, order and silence are strictly observed; so that they are alighted, and often entered, before their approach is announced. Even those whose fortunes are most ample, do not display the magnificence usual among the Persian nobility. In an entertainment, to which the British mission were invited, the dishes, consisting of all kinds of roasted, boiled, and baked meats, were dyed of various colours, and profusely ornamented with gold and silver leaf. The English were surprised, however, to see the servants jointing the meat with a penknife, and laying it on the plates with their hands. The amusements consisted in dancing girls, and displays of fire works, neither of which being very excellent in its kind, the pleasure afforded was extremely moderate. The nobles employed in offices at court are the most corrupted part of the nation, and, with a few exceptions, are guilty of every species of meanness.

Among Afghans of all descriptions, the favourite

Cahul.

amusement is hunting. They practise it against all descriptions of game, and in every possible variety of mode. Sometimes large parties assemble, and, forming a crescent, sweep the country, so as to inclose all the game to be found within the compass of a certain district. They do not excel much in shooting or hawking; but have a singular mode of chasing partridges. A number of horsemen, one after another, pursue the bird, and never allow it to rest a moment, till, being quite exhausted, it is easily beat down with a stick. Within doors, quail and cock-fighting afford favourite enjoyments; nor is any exercise which calls forth bodily strength and dexterity omitted. The Afghans are also a social people; they give frequent dinner parties, and delight in serious as well as gay conversation. The inhabitants of the towns find great enjoyment in excursions to the gardens in the vicinity, which command usually magnificent prospects.

Literature.

Education, to a certain extent, is very general among the Afghans. Moollahs, performing the office of schoolmasters, are established not only in towns, but even in every village. Unfortunately, the grand object is to enable their pupils to read the Koran in Arabic, often without understanding it; and not a fourth part of the lower orders can read their own language. The more advanced studies are the Persian classics, Arabic, grammar, logic, law, and theology. The two great seminaries of learning are Peshawer and Bukhara, the former of which has somewhat the preeminence. Although the superiority of the Persians in literature is acknowledged, yet their reputation of heresy deters all faithful *Soonnees* from repairing to their colleges. The Afghan princes, in general, have been eminent encouragers of learning. Ahmed Shaah held weekly assemblies at his palace, often prolonged to a late hour, and in which various topics of theology, law, and literature, were discussed. He and most of his successors have practised poetical composition, though their fame does not rest upon that basis. The most celebrated of the Afghan poets in Rehman; in whose pieces, however, so far as they were explained to Mr Elphinstone, he was not able to discover any merit; but he is willing to believe that this may have arisen from the defective nature of the few specimens which he obtained. More true poetical fire glows in the verses of Khooshhaul, a Khaun or Chieftain, whose valour maintained the independence of his tribe against the power of Aurungzebe. His odes seem well calculated to inspire his followers with the love of independence, and with a passion for war and glory. The poetical taste of the nation is also indicated by the reading of poetry being established as a regular profession, which is followed in the towns by a considerable number of individuals.

Agriculture.

The useful arts have made considerable progress. Agriculture is followed with assiduity. The grand process upon which its success depends, is that of irrigation, which is practised to a great extent, throughout all the kingdom. It is usually effected by small canals, into which the water is turned by dams, and sometimes by partial embankments. A much more laborious contrivance, called a *cauraz*, is frequently employed. A chain of wells

are sunk on a sloping field, and are connected by a subterraneous channel, so constructed, that the water of all the wells is poured into the lowest one, and thence into a water-course, from which it is conducted over the field. This laborious structure forms sometimes the mode in which a rich man employs his money; sometimes it is performed by an association formed among the poor. The ground is always watered before being ploughed. The ploughing is performed with two oxen, and is deeper than in India; the grain is sown always in broadcast, and a substitute for the harrow is formed by a plank, above which a man stands, to increase the pressure. The crop, in the course of its growth, is watered at least once, usually oftener. The sickle is the only instrument employed in reaping, and the grain is threshed by the treading of oxen. Two kinds of artificial grass are raised. Wheat forms the staple food of the inhabitants, and barley is chiefly used for horses. The cheapness of provisions, particularly of fruits and vegetables, is almost incredible. Grapes are considered dear when they exceed a farthing a pound, and the coarser species are sometimes given to cattle; the best apricots are less than a halfpenny a pound, and melons much cheaper. The smallest piece of copper money purchases ten pounds of spinage, twenty-five of cabbage, &c. The land is divided into very minute portions, and the proprietor and cultivator are usually the same person.

Of the manufactures of Afghanistan no mention is made; and they seem to be limited to objects of immediate consumption. Manufacturing industry is confined to the provinces annexed to the kingdom of Caubul by conquest from India. The most important branch is the manufacture of the shawls of Cashmeer. These beautiful fabrics are wrought in a shop or shed, consisting of a frame-work, at which from two to four people are employed. The plain shawls are woven with a shuttle, the variegated ones with wooden needles,—there being a needle for each species of coloured thread. A year or more is sometimes employed in the manufacture of a very fine shawl, but six or eight of the ordinary kind may be made in that period. The annual number produced in Cashmeer is estimated at about 80,000. The wool is imported chiefly from Great Thibet, by the way of Rodauk.

Afghanistan, from its situation, can only have an inland commerce. This is conducted by caravans, and the merchants usually employ camels for the conveyance of their goods; though when they have to cross any part of the chain of Hindu Coosh, horses and poneyes must be used. Considerable obstacles are encountered from the roughness of the roads, the difficulty of finding water and provisions, and the attacks of the predatory tribes. In traversing the territories of the latter, strict order is observed, and the march is covered by parties of horse stationed at proper distances. During the night, a large proportion of the caravan remain on watch. In towns they lodge in the caravansaries, which consist of large squares, along each side of which the apartments are ranged, with a mosque in the centre. Each merchant usually hires, at a very easy rate, two rooms for himself and his goods. Afghanistan,

Caul. from its want of manufactures, yields few commodities which can bear the expence of so laborious a transport. The principal are, fruits of all kinds, furs, madder, and assafostida. The produce of its subject provinces, the shawls of Cashmeer, the chintzes of Monltan, form more convenient articles of exchange. The trade of this country, however, is chiefly supported by its being the channel through which India maintains its communication with Persia and Toorkistaun. All the Indian manufactures are thus conveyed into those regions, while European goods are brought by the Russians, by way of Orenburg to Bukhara, and thence to Caulbul. The English mission, after having, with great difficulty, conveyed some large mirrors across the desert, hoping thus to inspire the king with a high idea of British manufacture, were much astonished and mortified, in the first private house which they visited, to see two mirrors of greater dimensions, which they understood had been brought by the above channel. From Toorkistaun itself are imported vast numbers of horses, for the supply of all the great men and armies of India. These, in consequence of the immediate channel by which they arrive, are there erroneously called Caulbul horses.

Principal Tribes.

Such are the general features of the kingdom of Caulbul; but every district has its separate tribe, divided and subdivided into others, and every one having something peculiar to itself. Our limits will only allow us to notice some of the most prominent of these distinctions. The western Afghauns are divided chiefly into the Ghiljies and Dooranees. The Ghiljies are the most warlike of all the Afghaun tribes. Ghuznee, situated in the heart of their territory, was the residence of the great Mahmood, and the Ghiljies formed the strength of those armies, with which he spread desolation over Asia. The conquest of Persia, at the beginning of the eighteenth century, was also effected by the Ghiljies, and they continued the ruling tribe till the invasion by Naudir Shauh. The restoration of the Afghaun monarchy being effected by Ahmed Shauh, the chief of the Dooranees, the Ghiljies have never regained their former ascendancy. Their constitution is extremely democratic, the administration, in some districts, verging almost on total anarchy. This spirit, which was always prevalent, has gained much additional strength since the sovereign ceased to belong to their tribe, and to add to his constitutional prerogative the more revered character of hereditary chief of the Ghiljies. This distinction now belongs to the Dooranees, who, since the elevation of Ahmed Shauh, have had the king of Caulbul for the head of their tribe. The great Dooranee Sirdars unite the influence derived from office and military command, to that which they enjoy in right of their birth. Accordingly, though the democratic principle is by no means crushed, the power both of the king and chiefs is greater here than in any other part of the kingdom. The character and deportment of the Dooranees are the subject of much panegyric. They are brave, honourable, hospitable, ardently attached to their tribe, and, at the same time, more liberal and humane than the rest of their countrymen. This preeminence is

Caulbul. admitted by the Ghiljies, even while they avow themselves their bitterest enemies. One of them being asked by Mr Elphinstone, what sort of people the Dooranees were, answered, " Good people; they dress well, they are hospitable, they are not treacherous." Being then asked how his countrymen treated such as fell into their hands, he replied, " We never let one escape; and now, if I had an opportunity, I would not give one time to drink water. Are we not enemies?" He added, " Our hearts burn, because we have lost the kingdom, and we wish to see the Dooranees as poor as ourselves."

The heights of Solimaun are occupied by the Khyberees, Vizerees, and Sheraunees, tribes still more barbarous than the names which they bear. They are all robbers, and some of them little better than savages, living in caves cut out from the rock. The Eusofzies inhabit the north-eastern extremity of Afghaunistaun, and occupy a fertile valley on the right bank of the Indus, watered by the river of Suant. They came into this region as conquerors, and have reduced all the original inhabitants to a state of slavery. The slaves being more numerous than the masters, perform all the laborious offices, and leave the latter in a state of almost total indolence. Although democracy be very prevalent throughout Afghaunistaun, it nowhere rises to such a height as among the Eusofzies, who indeed can scarcely be said to have any government whatever. The small number of the freemen, and a species of connection resembling that of a religious sect, which binds them to each other, are sufficient to prevent any violent disorder. Proud of this freedom, the Eusofzies regard themselves as the noblest of the Afghaun tribes, and look down with contempt even on the Dooranees.

Cashmeer was wrested from the Mogul by Ahmed Shauh, and has ever since continued a subject province of Caulbul. The soil is more fertile, and the inhabitants more industrious than in any other part of the Afghaun dominions. The capital of the same name is the largest city in the kingdom, containing from 150,000 to 200,000 inhabitants; and the revenue is estimated at 4,626,300 rupees, nearly half a million Sterling. The country is ruled by a governor, who exercises with severity all the functions of a sovereign. The Dooranees, who compose the military force, indulge in unusual licence, and treat this fine country as a conquered province. These oppressions give rise to frequent insurrections; but as the Cashmerians are endowed with a very small portion of courage, their risings are quickly crushed by the arrival of an Afghaun army; and the yoke is rendered more severe by the abortive attempt at emancipation.

The principal cities of Afghaunistaun are Peshawer, Caulbul, Candahar, and Heraut. Peshawer, at present the largest town in Caulbul, is situated in a most beautiful and fertile plain, of about 35 miles in diameter. It is watered by several branches of the river of Caulbul; and while it displays all the luxuriance of tropical fertility, is nearly environed by the snowy summits of the Hindoo Coosh, and the ridge of Solimaun. The city

Caubul. itself is upwards of five miles in circumference, is built upon an irregular surface, and contains about 100,000 inhabitants. The houses are built of brick, generally unburnt, in wooden frames. They are usually three stories high, the lower story being occupied by shops. The streets are narrow, not being designed for wheel-carriages; and, though paved, they are slippery and inconvenient. The shops are commodious, and well supplied with a variety of articles; while greens, curds, and particularly water, are called through the streets. The inhabitants present a varied and picturesque appearance; "people of the town in white turbans, some in large, white, or dark blue frocks, and others in sheep-skin cloaks; Persians and Afghans, in brown woollen tunics, or flowing mantles, and caps of black sheep-skin or coloured silk; Khyberces, with the straw sandals, and the wild dress and air of their mountains; Hindoos, uniting the peculiar features and manners of their own nation, to the long beard and the dress of the country; and Hazarehs not more remarkable for their conical caps of skin with the wool appearing like a fringe round the edge, and for their broad faces and little eyes, than for that want of the beard, which is the ornament of every other face in the city. Among these might be discovered a few women, with long veils that reached their feet. Sometimes, when the king was going out, the streets were choked with horse and foot, and dromedaries bearing swivels, and large waving red and green flags; and, at all times, loaded dromedaries, or heavy Bactrian camels, made their way slowly through the streets."

The Balla Hissar, or royal residence, is a castle of no strength. It contains some fine halls and magnificent gardens; but being only occasionally occupied by the king, is much neglected. This, and a fine caravansera, are the only public edifices that deserve notice. Few of the nobility have houses at Peshawer.

Caubul is a small city not supposed to contain more than 8000 inhabitants. It is, however, compact and handsome, and has for some time been the chief residence of the court. It is also a great emporium of trade, and the number and arrangement of its bazars have excited much admiration. Its climate and scenery have been a theme of panegyric to the writers of Persia and India. It is situated in a valley encompassed by mountains, and watered by numerous streams, which maintain perpetual verdure and fertility. A single district in the neighbourhood contains no less than 6000 orchards. In the province of Caubul are situated the remains of Ghuznee, once the proud capital of Western Asia. It is now reduced to 1500 houses, but proves its ancient greatness by some lofty minarets, situated without the walls, and by the tomb of the Sultan Mahmood, placed at the distance of three miles from the city.

Candahar is a large city, though, as Mr Elphinstone apprehends, not quite equal to Peshawer. It is built of an oblong form, and on a more regular plan than is usual in Asia. Its edifices, however, are not more elegant than those of the other cities of the kingdom. It is chiefly inhabited by Afghans, who, however, are by no means allowed to enjoy

the same rude freedom as on their mountains, but are subjected to a very rigorous system of law and police.

Heraut scarcely belongs to Caubul, being governed, almost independently, by a prince of the royal blood. It is a very ancient city, and somewhat surpasses the others in magnificence, being built, in a great measure, after the Persian model. It is supposed to contain about 100,000 inhabitants.

The following table of the population of the kingdom of Caubul, founded chiefly upon conjectural data, is supposed rather to fall short of, than to exceed the truth.

Afghans,	-	-	4,300,000
Beloches,	-	-	1,000,000
Tartars of all descriptions,	-	-	1,200,000
Persians,	-	-	1,500,000
Indians (Cashmerees, Jauts, &c.),	-	-	5,700,000
Miscellaneous tribes,	-	-	300,000
			14,000,000

See Elphinstone's *Account of Caubul and its Dependencies*. 4to. Lond. 1815. (a.)

CAUFIRISTAUN, a mountainous country of Asia, situated partly upon the Hindoo Coosh, and partly upon the Beloor Taugh. Its boundaries are Caubul, Budukshan, and Bulkh. This territory consists of vast mountains covered with snow, inclosing a few narrow but fertile valleys. It is inhabited by a singular people, the Caufirs, who, in religion, manners, and institutions, have remained entirely distinct from all their neighbours. Their religion is entirely Pagan, and they cherish the deadliest antipathy against the Mahometan name. To have killed a Mussulman is the highest glory at which a Caufir can aspire. Their religious observances bear no resemblance to those established in any part of India. They acknowledge a supreme Deity, whom they call Imra; and, in their ceremonies, represent him by a stone called Imrtan, or the holy stone. But they observe, "This stands for him, but we know not his shape." They have besides numerous inferior deities, consisting chiefly of deceased Caufirs, who have distinguished themselves by any eminent qualities. The best mode of securing an apothecosis, is by giving numerous feasts to the village, hospitality and good cheer being held by this people in the highest veneration. The Caufirs are in almost continual war with their neighbours. They sometimes openly attack, but more commonly seek to surprise, their enemy. On succeeding, they set up a war-cry, sing a song of triumph, and massacre all without distinction. Numerous privileges are attached to the having killed a Mussulman. He who has performed this exploit, may wear a turban stuck with feathers, may flourish his axe over his head in the dance, and may set up a pole before his door, with a pin stuck in it for every slaughtered enemy. Their arms are bows, four and a half feet long, with light arrows, sometimes poisoned. When pursued, they unbend their bows, and use them as poles, by the aid of which they leap from rock to rock with astonishing agility. About thirty years ago, all their neighbours united in a general confederacy for the

Causiric-
fann
Cavallo.

Cavallo.

extirpation of the Causirs. They penetrated the country in every direction, but found themselves unable to maintain their ground, and were soon obliged to retire with considerable loss.

The Causirs are hospitable in the extreme. A stranger arriving at one of their villages is not only welcomed, but is expected to visit each of the principal men, where he is regaled with every dainty which the house can afford. Their wealth consists of cattle and slaves; the latter are always their own countrymen, as they never spare the life of a Mussulman. The government is chiefly conducted by consultations among the rich men. Their dress consists principally of goat-skins, with the hair turned outwards, two of which form a vest, and other two a kind of petticoat. They are less addicted to hunting than the Afghans. The favourite amusement is dancing, of which they never tire. They cannot accommodate themselves to the Asiatic practice of seating themselves cross-legged on the ground, but sit in the European manner on benches and stools. They also use tables, and drink wine copiously, though not to intoxication, out of silver cups. These European habits have given rise to the hypothesis of their being a Greek colony, left during the expedition of Alexander; but all probability of this seems destroyed by the circumstance that their language contains no Greek admixture, and is closely allied to the Sanscrit. The two chief towns, or rather villages, of the Causirs, are Caumdash and Tsokooc. The former contains five hundred houses. See Mr Elphinstone's valuable *Account of Caubul*. (s.)

CAVALLO (TIZZIVUS), an electrician and natural philosopher; born at Naples 30th March 1749; and son of a physician established in that city.

His father died when he was only eleven years old; but he received a liberal education through the kindness of his friends, and completed his studies at the University of Naples. He was originally destined for commerce, and came to England in 1771, in order to obtain more complete information respecting the various objects of mercantile pursuit. But he soon abandoned his intention of adopting that mode of life, and determined to devote his time almost exclusively to the cultivation of science, and to literary employments connected with it. The splendid improvements which had been lately made in electricity, early directed his earliest attention to that amusing department of natural philosophy; but his studies were by no means confined to that subject; and the extent of his diversified researches may be understood from an enumeration of his principal publications.

1. *Extraordinary Electricity of the Atmosphere in October 1775*. *Phil. Trans.* 1776, p. 407. This observation was made at Islington, where the author then resided; and he seems to have been in some danger of becoming, like another Richmann, a martyr to his zeal in pursuit of his favourite science; for he says that he felt a number of severe shocks, while he was holding the wire of his kits.

2. *An account of some new Electrical Experiments*. *Phil. Trans.* 1777, p. 48. He here describes two atmospherical electrometers, and an exhausted tube containing some quicksilver; for illustrating the nature of electrical excitation. A paper of Mr Henly,

in the same volume, contains also some communications from Mr Cavallo, and in particular a remark on the opposite electricities which he detected in the bow and strings of his violin.

3. *New Electrical Experiments*. *Phil. Trans.* 1777, p. 388. Relating to changes of the colours of pigments, with a description of a pocket electrometer.

4. *A complete Treatise on Electricity*, 8vo. London, 1777. German by Gehler, 8vo. Leipz. 1785. French by Silvestre, 8vo. Paris, 1785. Ed. 4, 3 vols. 8vo. London, 1795.

This Essay contains a clear and familiar account of the principal facts respecting electricity, which had been discovered at the time of its publication, as well as of the best apparatus and of the most interesting experiments. The first part relates to the general laws of the science; the second to the hypothetical theories, by which different authors have attempted to explain them, but without any mention of the calculations of Alpinus and Cavendish; the third part gives an account of the practical arrangement of electrical apparatus, and the fourth of some original experiments and instruments; the fifth part in the later editions, is a republication of the author's *Essay on Medical Electricity*. To the fourth edition a third volume is added, containing an account of the recent discoveries respecting animal electricity; of the author's multiplier, for detecting the presence of small quantities of electricity, by the repeated operation of two condensers connected together; and of some original and very important experiments, relating principally to the effect of the contact of different metals with each other, and exhibiting an imperfect outline of those properties, which have since furnished Volta and Davy with their ingenious explanations of the phenomena of the electrochemical battery.

Mr Cavallo has inadvertently attributed to Nollet the honour of having first entertained the opinion of the electrical nature of thunder and lightning; the German translator has thought it necessary to vindicate the scientific character of his own country, by laying claim to this conjecture on behalf of Winkler, but Mr Silvestre has remarked, with a laudable impartiality, that both Germany and France must on this occasion give way to England, since the first suggestion of the identity is found in a paper of Stephen Gray, published in the *Philosophical Transactions* about 1735.

5. *An account of some new Experiments in Electricity*. *Phil. Trans.* 1780, p. 15. Consisting of remarks on Professor Lichenberg's discovery of the peculiarity of the figures exhibited by strewing powders on the cake of the electrophorus; with an account of two improved electrometers.

6. *Thermometrical Experiments and Observations*. *Phil. Trans.* 1780, p. 585. This was a Bakerian lecture, delivered by appointment of the President and Council of the Royal Society; an appointment which entitles the lecturer to a small fee, left by the will of Mr Henry Baker, but which is commonly considered as rather complimentary than lucrative. These experiments relate to the effect produced by colouring the bulb of a thermometer exposed to the sun's rays, and to the intensity of heat at different

Cavallo. distances from its source. The most refrangible colours appeared to absorb the most heat; and it was observed that even the day-light, without sunshine, occasioned a perceptible difference in the indications of the different thermometers.

7. *An Essay on Medical Electricity*, 8vo, London, 1780. It is seldom that persons not medical have been sufficiently incredulous in their opinions respecting the operations of remedies; and the whole of the expectation held out in this work, has certainly not been fulfilled by later experience; but, as a candid and distinct relation of cases, it may still have its value.

8. *Account of a Luminous Appearance*. *Phil. Trans.* 1781, p. 329. One of the permanent arches since found to be connected with the aurora borealis. It was so bright that the stars could not be seen through it, and lasted about an hour.

9. *Thermometrical Experiments*. *Phil. Trans.* 1781, p. 509. A Bakerian lecture, relating to the evaporation of ether, to the expansion of mercury, and to a thermometrical barometer; that is, a very delicate thermometer, for ascertaining the temperature of boiling water at different heights above the level of the sea, according to the idea then suggested by Sir George Shuckburgh, and very lately resumed by other natural philosophers. Mr Cavallo observes that the instrument has the advantage of being very portable; but that unless the quantity of water be considerable, its boiling temperature will be somewhat unsteady.

10. *A Treatise on the Air and other Permanently Elastic Fluids*. 4to, Lond. 1781. This elaborate work commences with the principles of chemistry and of hydrostatics, and proceeds to relate all the known properties of the different kinds of elastic fluids, many of which had been very lately discovered; these are followed by an account of some original experiments, for example, on the gas produced by the deflagration of gunpowder, which is found to be chiefly nitrogen and carbonic acid, without any nitric oxyd; on the explosion of hydrogen mixed with atmospheric air, and on the evolution of gas from plants, respecting which the author finds some reason to differ from the opinions of Dr Ingenhuz. Considering that Mr Cavendish had not then discovered the composition of the nitric acid, it must be allowed that the experiments on gunpowder may justly be deemed an important step in the progress of chemical science.

11. *Description of an Improved Air Pump*. *Phil. Trans.* 1783, p. 435. The improvement was made by Haas and Hurter, and consisted in a mode of opening the valve of oiled silk mechanically, when the elasticity of the air became too weak to raise it. The rarefaction obtained went to about the thousandth of an atmosphere: in this state the air transmitted electricity, with a light equally diffused; and the balls of the electrometer exhibited no divergence. Some later improvements are said to have carried the rarefaction to $\frac{1}{5000}$.

12. *Description of a Meteor*. *Phil. Trans.* 1784, p. 108. This observation was made at Windsor, and is highly valuable, from the circumstance of a noise like thunder having been heard, about ten mi-

nutes after the explosion of the meteor was seen; Cavalli hence the author concludes that its direct distance was 130 miles, and its height 56 $\frac{1}{2}$.

13. *The History and Practice of Erotation*, 8vo, Lond. A work of temporary rather than of permanent interest; but which it was the more natural for Mr Cavallo to undertake, as he was one of the first who had made experiments on the means of employing hydrogen for raising bodies into the air by its levity.

14. *Mineralogical Tables*. f. Explanation. 8vo, Lond. 1785; containing a comparison of the different systems of mineralogical arrangement then most generally adopted, but at present almost wholly superseded by later methods.

15, 16. *Magnetical Experiments and Observations*. *Phil. Trans.* 1786, p. 62; 1787, p. 6. Two Bakerian lectures; the former relates chiefly to the magnetism of brass, and of some other metals, generally rendered discoverable by hammering them; in the latter, the same subject is continued; and it is shown that the same powers may be detected in the metals in question without hammering them, if they are placed on a very clean and wide surface of quicksilver. The limit, at which red hot iron begins to be attracted by a magnet, is found to be the heat at which it ceases to be visible in the day-light. A considerable change is observed in the magnetic powers of iron during its solution in acids: and the author endeavours to apply these experiments to the explanation of the variation of terrestrial magnetism, as derived from the effects of heat, and from internal changes in the constitution of the earth. Mr Bennet has endeavoured to explain the phenomena observed by Mr Cavallo, from the accidental operation of foreign causes, but he has not been perfectly successful in the attempt.

17. *A Treatise on Magnetism in Theory and Practice*, 8vo. Lond. 1787. Ed. 3. 1800. The arrangement resembles that of the Treatise on Electricity: under the head of Theory the name of Alpinus is mentioned with due respect. The original experiments are chiefly reprinted from the *Philosophical Transactions*: there is also a description of an improved mode of suspension for a magnetic needle, and there are several letters from Dr Lormer on the terrestrial variation.

18. *Of the Methods of manifesting the presence of small quantities of Electricity*. *Phil. Trans.* 1788, p. 1. In this Bakerian lecture, Mr Cavallo proposes an improvement on Volta's condenser, and makes some remarks on Mr Bennet's doubler, which he thinks objectionable on account of the impossibility to deprive the plate of a small quantity of electricity adhering to it. His own instrument has the advantage of avoiding the friction to which the condensers and doublers in their original form were liable.

19. *Of the Temperament of musical intervals*. *Phil. Trans.* 1788, p. 238. The author's particular object is to calculate the exact scale for the division of a monochord, according to the system of a perfectly equal temperament: but he very candidly remarks, that "for playing solos," the usual temperament is the best, "giving the greatest effect to those concords which occur most frequently;" and he says,

Cavallo.

that when a harpsichord was tuned according to the scale laid down on this monochord, the harmony was perfectly equal throughout, and the effect "the same as if one played in the key of E natural on a harpsichord tuned in the usual manner."

20. *Description of a new electrical Instrument, capable of collecting together a diffused quantity of Electricity.* *Phil. Trans.* 1788, p. 255. This collector consists of a fixed plate of tin, situated between two moveable ones; it is said to be more certain in its operation than the condenser, the results of which are liable to considerable irregularities from various accidents, and to be more free from the inconvenience of permanent electricity than the doubler.

21. *Description of a Micrometer.* *Phil. Trans.* 1791, p. 288. *Description and use of the Mother of Pearl Micrometer.* 8vo. Lond. 1798. A thin slip of mother of pearl with a fine scale engraved on it, placed in the focus of the eye-piece of a telescope: its principal use is for ascertaining the distance of an object, of known dimensions, by its apparent magnitude thus measured; for instance, for judging of the distance of a body of troops, in military operations: the mother of pearl is found to be more convenient than glass for receiving the divisions, and to be sufficiently transparent for transmitting the images of the respective objects.

22. *On the Multiplier of Electricity.* *Nicholson's Journal*, I. p. 394. 1797. In this letter Mr Cavallo attempts to show the advantage of his instrument over doublers of all kinds: Mr Nicholson, in a very respectful answer, expresses his doubts whether the objections to the doubler do not arise from its extreme sensibility only, as demonstrating the existence of an electricity too weak to affect the other instruments compared with it: Mr Cavallo had however remarked, that the inconvenience partly arose from the greater intensity of the charge communicated to the plate of the doubler during the operation, which required a longer time for the restoration of the natural equilibrium.

23. *An Essay on the medicinal properties of factitious Airs, with an Appendix on the nature of the Blood.* 8vo. London, 1798. The modern improvements in pneumatic chemistry have been still less productive of advantage to practical medicine, than the discovery of the powers of electricity, and this work can scarcely be considered as having conferred any material benefit on the public. The observations on the blood are chiefly the result of a minute and careful microscopical examination of its particles, but the author was not particularly happy in the light which he employed for viewing them.

24. *Elements of Natural or Experimental Philosophy*, 4 vols. 8vo. Lond. 1803. This work, the last and most valuable of the author's publications, will long serve as a useful manual of the most important parts of the mechanical and physical sciences. The first volume is devoted to mathematical and practical mechanics; beginning with matter and motion, and proceeding to simple machines. The second relates, first, to fluids; to the principles of hydrostatics, cohesion, hydraulics, pneumatics, sound, and music; and secondly, to the most important parts of chemistry. In the third volume we find the doctrine of

VOL. II. PART II.

heat, optics, electricity, and magnetism; and the fourth, besides astronomy and the use of the globes, contains a compendium of the history of aerostation; an account of meteors, including the recent discoveries respecting aeroliths; and a collection of useful tables.

25. Mr Cavallo was also an occasional contributor to several *Periodical Publications*; and his critical articles were not in every instance anonymous. He was made a Member of the Royal Academy of Naples in 1779, and a Fellow of the Royal Society of London in the month of December of the same year.

It is impossible to hesitate in attributing to Mr Cavallo the possession of very considerable powers of mind; but these powers seem to have been of a different nature from those which have distinguished some other individuals, remarkable for the faculty of acute reasoning, and brilliant invention, and apparently born to succeed in the highest flights of genius. Mr Cavallo's talents appear to have had more of the imitative character, and to have been rather calculated for the attainment of excellence in the fine arts than in science; but his memory was uncommonly retentive, and his industry seems to have been indefatigable. He used to relate, that when he was first compelled to study Euclid, he felt himself utterly incapable of comprehending the train of argumentation, and he was obliged to get the whole work by heart, both propositions and demonstrations, in order to impress the conclusions strongly on his mind; this expedient answered his purpose very well, as long as the impression lasted; but after some years he had forgotten his task, and he was obliged to go through the whole again, in the same manner, still finding it easier to commit the eight entire books, with all the unmeaning letters of reference, to the care of his ever faithful memory, than to acquire the spirit of the mode of reasoning, and to anticipate the steps of the demonstration; although, after having performed this second labour, he felt himself sufficiently master of the subject. It may be observed that he possessed considerable skill in music; and music was called by the ancients an imitative art; a description which may indeed be somewhat objectionable, with regard to the province of the original composer, who creates something altogether unlike what had ever before existed; but which may not improperly be applied to the occupation of a performer; and Mr Cavallo, even when his hearing was impaired, still retained a very correct taste in the execution of vocal music. He possessed also his country's aptitude for the painter's art; and he was particularly happy in cutting out striking likenesses of his acquaintances in paper. The principal object of his life was to collect and arrange the labours of others; and he was so much in the habit of collecting, that he had for many years made it his amusement to collect specimens of the hand writing of eminent persons, which he had extended to an immense number of individuals, of different ages and countries. But he was by no means incapable of copying from the great book of nature; and he made, in the course of his various researches, a number of original experiments, well calculated to

Cavallo.

Cavan
I
Cavan.

illustrate particular questions, relating to the sciences which he cultivated. In the latter part of his life, he had discontinued his attendance at the meetings of the Royal Society, as well as his contributions to the *Transactions*; but he was in the habit of frequenting some other literary conversations, at which he constantly met some of his oldest and kindest friends. A short time before his last illness, he was engaged in some experiments on Mr Deluc's perpetual pile of paper, and on the electricity of different specimens of crystals; but he does not appear to have obtained any new results from these investigations. He died at his residence in Wells Street, on the 26th of December 1809, and was buried in St Pancras Church Yard, near the tomb of General Paoli, with whom he had long been on terms of the greatest intimacy. *Literary Memoirs of Living Authors*; *Dance's Collection of Portraits*; *Gent. Mag.* 1809; *Suppl. Monthly Mag.* 1810. p. 86; *Aikin's General Biography*, Vol. X.; *Chalmers's Biographical Dictionary*, Vol. VII. (X. A.)

Extent and
Divisions.

CAVAN, COUNTY, is situated midway between the Irish Sea and the Atlantic Ocean, from the shores of which its eastern and western extremities are each distant about 14 miles. Its boundaries towards the north are the mountains of Bullynageerah and Slieve Russel, and the waters of Lough Erne; the mountains of Leitrim mark its western extremity, while Bruce hill rises abruptly on the south. Its greatest length, from east to west, is about 51 English miles; and its greatest breadth, from north to south, 28 miles. Its area contains 758 square miles, or about 499,957 English acres. It is divided into seven baronies; Castleraghan, Clontmahon, Clonkee, Upper Loughtee, Lower Loughtee, Tullygarvy, Tullyhanco, and Tullyhan; and contains 30 parishes, of which 26, with 24 churches, are in the diocese of Kilmore, three in the diocese of Ardagh, and one in that of Meath. The principal places in it are Cavan, Kilmore, the see of a Bishop, Killyshandra, Belturbet, and Virginia; but they are all very small.

Face of the
Country.

Cavan is almost entirely covered with hills; and in the north, the surface, soil, and climate, are equally bleak and uncomfortable. In some places, however, the appearance of the country is more favourable, especially in the vicinity of Farnham. Bogs and lakes are very numerous; so that, according to Mr Young, they, together with the hills, occupy at least half the county. The greatest part of the waters, which issue from the lakes of West Meath, flow through Cavan, till they discharge themselves into Lough Erne, and in their passage, in some places, they expand into small lakes, and in others, retain the appearance and character of rivers. The shores of many of these lakes are very beautiful. The form and outline of Lough Ramor, near Virginia, are good, but the banks are flat; towards the upper end of it, there is some little wood. It contains pike and trout. Near Bruce hill is the great lake of Gawnagh, out of which the Erne flows. Between Bailyborough and King's Court, on the summit of a mountain, is a famous pool, called Lough-an-Leighaghs, or the healing lake. To its waters many healing virtues are ascribed; but its natural peculiarities are more undoubted. It is never observed above a stated level; it has no visible outlet,

nor any apparent source from which it derives its waters; and it never has been found to vary in temperature. Its extent is not above one square rood; on the surface the water is clear, but deeper it is muddy; and its medicinal qualities are said to reside in this mud. Perhaps the finest lakes in the county, with respect to picturesque beauties, are those near Farnham, which communicate with each other by a river.

The principal river is the Erne; the source of it has been already noticed; it flows through the barony of Tullyhanco, where it forms the extensive Lough Oughter, containing many islands, among which is Cloghter, where Bishop Bedel was confined by the rebels, in 1641. From this lough the Erne flows with an increased stream to Belturbet, and discharges itself into Lough Erne.

There is not much variety of soil in this county; soil in the north it consists principally of a cold, wet clay. Near Farnham, it is a good loam, lying on sixty gravel, limestone, or blue whinstone; from Cavan to Belturbet, it is dry, rocky, and rough; from Killyshandra to Knockwin, dry gravel; and from Cavan to Virginia, heathy. In many parts, especially about Kilmore, there is plenty of limestone, but it is little used for agricultural purposes; near Killyshandra, there are beds of marl, which is laid on the heathy moors with success. There is said to be coal in Slieve Russel, but if there is, it is not worked, as the county is supplied with it from Newry. A great deal of turf is also burnt for fuel. According to the *Natural History of Ireland* (Dublin, 1726), iron ore was formerly dug "in this county, in a place called Doubally, in a dry mountain." At present, it is not known. There are several mineral waters in Cavan, particularly at Swadlingbar, Derrylester, Derrinduff, and Owen Brien, but they have not been accurately analysed.

The largest estates in this county are two of 30,000 Acres and 26,000 acres; besides these there are none of very great extent. Nearly the whole of the land, or about three fifths, according to Mr Young, is under tillage, but the agriculture in every respect is very bad. The size of the farms is from 50 to 100 acres, but these are generally divided into farms of from two to twenty acres, which are let to the manufacturers or "cottars," who pay a high rent for them, by means of their other employments. Their principal object is to raise a sufficient quantity of oats and potatoes to feed their families, and of flax to give employment to the women and children. Most of the land is dug with the spade and trenched as in Armagh; where the plough is used, they put three or four horses to it; and when Mr Young visited the county, he found that all over it, the horses were yoked to the plough and harrows by the tail; that practice, however, is now disused. Almost the only grain sown is oats, which are reckoned to be in the proportion of seventy to one, to all other grain; there is scarcely any wheat. In 1809, there were 4300 acres of flax, from which 6500 bushels of seed were saved. Though the very tops of the hills are tilled, yet it does not appear that this county produces more grain than is necessary for its own consumption; nor has the bounty on the inland carriage of corn to Dublin increased the very trifling quantity brought to that market. From the coldness and moist

Cavan. ture of the climate, all the corn of Cavan is obliged to be kiln-dried.

The stock-farms generally consist of about 100 or 150 acres; the farmers buy young cattle and sell them again without fattening; a few, however, fat bullocks or sheep, but the latter are very poor. There are very few dairy farms, though from these, as they are in the richest parts of the county, a good deal of butter is sent. Many pigs are kept by the cottars; and near all the cabins are to be seen goats tethered to the tops of the banks, or "ditches," as they are here called, which divide the fields.

Woods. Cavan was formerly celebrated for its extensive woods, and trees of an immense size; but, at present, it is in general bare of timber, except near Kilmore, Farnham, and a few other places. Mr Wakefield remarks, that the ash is confined to parts of this county, and to Tyrone and Fermanagh.

Manufactures. The linen manufacture is the staple; chiefly a thin linen seven-eighths wide. The weaving of it, however, is not so general as the spinning of the flax, which is the principal employment of the women and children in all parts of the county. Killyshandra and Coothill are the principal markets for linen; in the latter, great quantities of brown linen are sold. There are several bleaching-grounds in the county. It is probable, however, that the cotton manufacture will root out that of linen, as, from the greater demand for cotton goods, it has already induced the manufacturers of Cavan to turn much of their attention to it. The food of the inhabitants is very plain and frugal, being little else besides oatmeal, potatoes, and milk; the two first are the only provisions for sale in any of the markets. The labourers are paid partly in money and partly in goods, and the weavers till enough for their own food.

County Cens. The county cess or tax is not collected per acre, but by a division called a "carvel." A town land is divided into so many carvels, each of which, though of a totally different extent, pays the same sum.

Population. According to Dr Beaufort, in the year 1792, there were 16,814 houses; 81,570 inhabitants; 18.4 Irish acres to a house; 3471 inhabitants to a square Irish mile; 12,928 houses of one hearth; 571 of two; 222 of three; 65 of four; 34 of five; 36 of six; 15 of seven; 13 of eight; 7 of nine; 7 of ten; 19 more than ten, and under forty-four; none returned above forty-four: 559 new, and 2763 belonging to paupers. The total 18,159. A census, taken in 1797, states the number of houses at 18,056, which, reckoning as Dr Beaufort does, five persons to a house, would give a population of 90,280. According to Mr Wakefield, this county contains at least 6000 freeholders, one half of whom, he says, neglect to enrol their names. But these were registered up to February 1815, 134 fifty pound freeholders, 177 twenty pound, and 5720 forty shillings; in all, 6031. Of these, according to the same author, 1000 are under the Earl of Farnham, and his relation Colonel Barry. The proportion of Catholics to Protestants is as five to one; but there is only one Catholic who possesses landed property to a considerable extent. The Protestants are mostly dissenters.

See Coote's *Statistical Account of Cavan*.—Dr Beaufort's *Memoir of a Map of Ireland*.—Wakefield's *Account of Ireland*.—Young's *Tour in Ireland*.

(c.)

CAVANILLES (ANTONIO JOSEPH), a Spanish Ecclesiastic, who devoted himself with great assiduity to the study of Botany, and has published several important works, was born in 1745 at Valencia. He received his first education among the Jesuits in that university, and he ever retained the urbanity of character and manners characteristic of that celebrated order of men. These were, in him, accompanied with more estimable qualities of the heart than are usually attributed to that order, or than any other exclusively possesses. He early devoted himself to the studies of divinity and philosophy, and was distinguished for diligence and ability, not only in these pursuits, but in the mathematics, history, and belles lettres. He afterwards removed to Murcia, where he acquired so much credit, that he was chosen by the late Duke de l'Infantado to superintend the education of his sons. In the house of this nobleman he was perfectly domesticated, and when, after a course of years, the death of his patron broke up a circle of more than usual domestic virtue and felicity, at least in that elevated rank of life, the Abbé Cavanilles became only a more valuable and confidential friend of the survivors. He accompanied the sons of the Duke, in their father's lifetime, to Paris in 1777, where he resided twelve years, adding to his various information, and particularly cultivating the sciences of Botany, with all the aids which that celebrated capital was so well calculated to afford. Here he was more particularly associated with the famous Jussieu, and the pupils of his school. From the Linnaean botanists of Paris he was a good deal estranged. Yet he acquired a great inclination towards the Swedish school, and imbibed many of its good principles.

The first publication of the Abbé Cavanilles was in French, entitled *Observations sur l'article "Espagne" de la nouvelle Encyclopédie*. This pamphlet contained a defence of his country, against what appeared to him an unfair attack upon it; but we know not the particular subjects of the discussion. We have no difficulty in conceiving that they might be manifold, and that there were few opinions upon which a man of Cavanilles' correctness and orthodoxy of character, to say nothing of his patriotism, was likely to agree with the writers of the above mentioned celebrated work.

He soon after devoted himself to a study which promised him a less thorny path. In 1785 he published at Paris his first *Dissertation upon Monadelphous Plants*, a Latin 4to, containing the species of the genus *Sida*, with some plants nearly related thereto. The plates, uncoloured, were executed from his own drawings; as were those of the rest of his numerous publications. The specimens delineated in this first essay, were too small and imperfect. In that respect his following dissertations, making ten in all, have a considerable superiority. His subsequent figures were also better engraved. The descriptions are full and correct; the new species numerous; and the specific characters tolerably classical, though not quite uncontaminated by the feebleness and ambiguity of the French school. This work, in its beginning, not being received by the Linnaean botanists of Paris, and especially by L'Heritier, with

Cavanilles.

Cavanilles. any respectful attention, the author, in an evil hour, was induced to complain, in the *Journal de Paris*, of neglect, and of injustice. L'Heritier had not noticed the book in his *Stirpes Novæ*; had published the same plants by different names, without citing Cavanilles; and had even antedated some of his own *Fasciculi*, to conceal, as it appeared, this literary incorrectness. His reply could not, in the opinion of unprejudiced witnesses, clear him of illiberal conduct; though, it is very certain, he neither did nor could borrow any thing from Cavanilles. It would have been better to have declared the truth; that his own plates were already engraved with different names, or that he had at least chosen such as seemed to him preferable. The authority of L'Heritier's works, by their transcendent merit, has prevailed, while Cavanilles has retained all the credit due to correctness of principle and intention. The 9th and 10th *fasciculi* of Cavanilles, on the *Monadelphous* Plants, were indeed published at Madrid, to which place the author returned in 1790. The number of plates, in the whole work, are 296, many of which, especially in the earlier part, contain several species. It cannot be denied that the merit of this work kept increasing as it advanced. The abilities of the writer gained strength by exercise, and his knowledge was enriched by experience. He is charged with admitting, as *monadelphous*, too many plants, the union of whose stamens is very slight or uncertain; but it were ungrateful to complain of any book for the riches of its materials. A more real fault is, that usual one, of too great, and artificial, a subdivision of genera. This is also the fault of the school in which he studied, though the great man at its head is perhaps as free from it as any leading writer.

Soon afterwards the Abbé Cavanilles began a larger and more comprehensive publication, in folio, entitled, *Icones et Descriptiones Plantarum quæ aut sponte in Hispania crescunt, aut in Hortis hospitantur*. The first volume appeared in 1791, containing 100 plates, with ample descriptions. It was followed by five more, of equal size and merit, the last of which came out in 1801. The whole work is enriched with critical remarks, and with much economical, as well as what may be called picturesque and sentimental, matter, respecting many native Spanish plants. The exotic part of these volumes is derived from the highly valuable and novel discoveries of the Spaniards in Mexico, Peru, and Chili, and the acquisitions of some voyagers to New Holland and the Philippine Islands. Hence numerous very fine plants, originally discovered by our own celebrated circumnavigators, but unfortunately not yet published by them, have first been made known in the pages of Cavanilles.

In the course of the botanical tours of our author, he collected materials for a general *History of the Kingdom of Valencia*, which appeared in 1795, in Spanish, making two volumes. This work, which we have never seen, is said to be rich, not only in what relates to the three kingdoms of nature, but likewise in statistic and antiquarian information.

Having, in June 1801, been entrusted with the Directorship of the Royal Garden at Madrid, he

published in 1802, another work in his native tongue, containing the characters and descriptions of the plants demonstrated in his public botanical lectures. To these are prefixed an exposition of the elementary principles of the science, with explanations of botanic terms. Cavanilles was also a frequent and important contributor to the periodical work, entitled *Anales de Ciencias Naturales*, published at Madrid. Some observations of his, translated from thence, may be found in Dr Sim's and Mr König's *Annals of Botany*, Vol. I. 409. The first of these indeed, relative to certain seemingly lenticular bodies, supposed to have an important share in the impregnation of ferns and mosses, he has himself contradicted, as arising from an optical deception. His candid avowal of this, in a letter to Dr Swartz, is published in volume second of the said *Annals*, p. 587. We think him also mistaken in the true stigma of the *Iris*, his opinion being sufficiently refuted by those of Kolreuter and Sprengel, given in a note, in the very place just quoted; nor is his idea of the stamens of certain *Asclepiadeæ* correct. If he errs however, he errs with great authorities.

The subject of our present memoir undoubtedly excelled more in practical observation, than in physiological speculation. He is said to have prepared, and partly printed, the first volume of a *Hortus Matritensis*, being a sort of sequel to his *Icones*; for it was intended to contain, not merely the figures and descriptions of curious or new plants from the garden, but also of rare dried specimens from the museum at Madrid. This work, with any other project in favour of science which he might have formed, was cut short by his death, in May 1804, in the fifty-ninth year of his age. An engraved portrait of the Abbé Cavanilles, at the age of forty-four, is given in Schrader's *Neues Journal*, published at Erfurt, in 1805. Dr Swartz in the *Annals of Botany* above quoted, gives this testimony to his worth. "Cavanilles was, like many others, often rather hasty in his conclusions; but always eager to promote science. He was, indeed, a man of a very noble mind, and of the most generous communicative turn; so that I feel I have lost much by his untimely decease, which I shall ever regret." In these sentiments the writer of this article most sincerely concurs. (J.J.)

CAVENDISH (HENRY), a great and justly celebrated Chemist, Natural Philosopher, and Astronomer; son of Lord Charles Cavendish, and grandson of William, second Duke of Devonshire; born the 10th of October 1731, at Nice, where his mother, Lady Anne Grey, daughter of Henry, Duke of Kent, had gone, though ineffectually, for the recovery of her health.

Of a man, whose rank, among the benefactors of science and of mankind, is so elevated as that of Mr Cavendish, we are anxious to learn all the details both of intellectual cultivation and of moral character, that the labours of a biographer can discover and record. Little, however, is known respecting his earliest education: he was for some time at Newcombe's school, an establishment of considerable reputation at Hackney; and he afterwards went to Cambridge: but it is probable that he acquired his

Cavendish. taste for experimental investigation in great measure from his father, who was in the habit of amusing himself with meteorological observations and apparatus, and to whom we are indebted for a very accurate determination of the depression of mercury in barometrical tubes, which has been made the basis of some of the most refined investigations of modern times. "It has been observed," says M. Cuvier, "that more persons of rank enter seriously into science and literature in Great Britain than in other countries: and this circumstance may naturally be explained from the constitution of the British Government, which renders it impossible for birth and fortune alone to attain to distinction in the state, without high cultivation of the mind; so that amidst the universal diffusion of solid learning, which is thus rendered indispensable, some individuals are always found, who are more disposed to occupy themselves in the pursuit of the eternal truths of nature, and in the contemplation of the finished productions of talent and genius, than in the transitory interests of the politics of the day." Mr Cavendish was neither influenced by the ordinary ambition of becoming a distinguished statesman, nor by a taste for expensive luxuries or sensual gratifications; so that, enjoying a moderate competence during his father's life, and being elevated by his birth above all danger of being despised for want of greater affluence, he felt himself exempted from the necessity of applying to any professional studies, of courting the approbation of the public either by the parade of literature or by the habits of conviviality, or of ingratiating himself with mixed society by the display of superficial accomplishments. It is difficult to refrain from imagining that his mind had received some slight impression from the habitual recurrence to the motto of his family: the words *cavendo tutus* must have occurred perpetually to his eye; and all the operations of his intellectual powers exhibit a degree of *caution* almost unparalleled in the annals of science; for there is scarcely a single instance, in which he had occasion to retrace his steps, or to recal his opinions. In 1760, he became a Fellow of the Royal Society, and continued for almost fifty years to contribute to the *Philosophical Transactions* some of the most interesting and important papers, that have ever appeared in that Collection; expressed in language which affords a model of concise simplicity and unaffected modesty; and exhibiting a precision of experimental demonstration, commensurate to the judicious selection of the methods of research, and to the accuracy of the argumentative induction; and which have been considered, by some of the most enlightened historians, as having been no less instrumental in promoting the further progress of chemical discovery, by banishing the vague manner of observing and reasoning, that had too long prevailed, than by immediately extending the bounds of human knowledge with respect to the very important facts, which are first made public in these communications.

1. *Three Papers, containing Experiments on Facilitious Air.* (*Phil. Trans.* 1766, p. 141.) It had been observed by Boyle, that some kinds of air were unfit for respiration; and Hook and Mayow had looked still further forwards into futurity with prophetic

glances, which seem to have been soon lost and forgotten by the inattention or want of candour of their successors. Hales had made many experiments on gases, but without sufficiently distinguishing their different kinds, or even being fully aware that fixed air was essentially different from the common atmosphere. Sir James Lowther, in 1783, had sent to the Royal Society some bladders filled with coal damp, which remained inflammable for many weeks; little imagining the extent of the advantages which were one day to result to his posterity from the labours of that society, by the prevention of the fatal mischiefs which this substance so frequently occasioned. Dr Seip had soon after suggested, that the gas which stagnated in some caverns near Pymont was the cause of the briskness of the water; Dr Brownrigg of Whitehaven had confirmed this opinion by experiments in 1741; and Dr Black, in 1755, had explained the operation of this fluid in rendering the earths and alkalis mild. Such was the state of pneumatic chemistry when Mr Cavendish began these experimental researches: He first describes the apparatus now commonly used in processes of this kind, a part of which had been before employed by Hales and others, but which he had rendered far more perfect, by the occasional employment of mercury. He next relates the experiments, by which he found the specific gravity of inflammable air to be about $\frac{1}{11}$ of that of common air, whether it was produced from zinc or otherwise: first weighing a bladder filled with a known bulk of the gas, and then in a state of collapse; and also examining the loss of weight during the solution of zinc in an acid, having taken care to absorb all the superfluous moisture of the gas by means of dry potass. He also observed, that the gas obtained during the solution of copper in muriatic acid was rapidly absorbed by water, but he did not inquire further into its nature. The second paper relates to fixed air, which was found to undergo no alteration in its elasticity when kept a year over mercury; to be absorbed by an equal bulk of water or of olive oil, and by less than half its bulk of spirit of wine; to exceed the atmospheric air in specific gravity by more than one half, and to render this fluid unfit for supporting combustion, even when added to it in the proportion of 1 to 9 only. Mr Cavendish ascertained the quantity of this gas contained in marble and in the alkalis; but his numbers fell somewhat short of those which have been determined by later experiments: he also observed the solubility of the supercarbonate of magnesia. In the third part, the air produced by fermentation and putrefaction is examined: Macbride had shown that a part of it was fixed air; and our author finds that sugar and water, thrown into fermentation by yeast, emit this gas, without altering the quantity or quality of the common air previously contained in the vessel, which retains its power of exploding with hydrogen, exactly like common air: he also shows that the gas thus emitted is identical with the fixed air obtained from marble; and that the inflammable air, extricated during putrefaction, resembles that which is procured from zinc, although it appeared to be a little heavier.

2. *Experiments on Rathbone Place Water.* *Phil.*

Cavendish. *Trans.* 1767. P. 92. In this paper Mr Cavendish shows the solubility of the supercarbonate of lime, which is found in several waters about London, and is decomposed by the process of boiling, the simple carbonate being deposited in the form of a crust: the addition of pure lime water also causes a precipitation of a greater quantity of lime than it contains. These conclusions are confirmed by synthetical experiments, in which the supercarbonate is formed, and remains in solution.

3. *An Attempt to explain some of the principal Phenomena of Electricity by means of an Elastic Fluid.* *Phil. Trans.* 1771. P. 364. Our author's theory of electricity agrees with that which had been published a few years before by *Æpinus*, but he has entered more minutely into the details of calculation, showing the manner in which the supposed fluid must be distributed in a variety of cases, and explaining the phenomena of electrified and charged substances, as they are actually observed. There is some degree of unnecessary complication from the great generality of the determinations: the law of electric attraction and repulsion not having been at that time fully ascertained, although Mr Cavendish inclines to the true supposition, of forces varying inversely as the square of the distance: this deficiency he proposes to supply by future experiments, and leaves it to more skilful mathematicians to render some other parts of the theory still more complete. He probably found, that the necessity of the experiments, which he intended to pursue, was afterwards superseded by those of Lord Stanhope and M. Coulomb; but he had carried the mathematical investigation somewhat further at a latter period of his life, though he did not publish his papers: an omission, however, which is the less to be regretted, as M. Poisson, assisted by all the improvements of modern analysis, has lately treated the same subject in a very masterly manner. The acknowledged imperfections, in some parts of Mr Cavendish's demonstrative reasoning, have served to display the strength of a judgment and sagacity, still more admirable than the plodding labours of an arithmetical calculator. One of the corollaries seems at first sight to lead to a mode of distinguishing positive from negative electricity, which is not justified by experiment; but the fallacy appears to be referable to the very comprehensive character of the author's hypothesis, which requires some little modification to accommodate it to the actual circumstances of the electric fluid, as it must be supposed to exist in nature.

4. *A Report of the Committee appointed by the Royal Society, to consider of a Method for securing the Powder Magazine at Purfleet.* *Phil. Trans.* 1773. P. 42. *Additional Letter.* P. 66. Mr Cavendish, and most of his colleagues on the committee, recommended the adoption of pointed conductors: Mr Wilson protested, and preferred blunt conductors; but the committee persisted in their opinion. Later experiments, however, have shown, that the point in dispute between them was of little moment.

5. *An Account of some Attempts to imitate the Effects of the Torpedo by Electricity.* *Phil. Trans.* 1776. P. 196. The peculiarity of these effects is

shown to depend in some measure on the proportional conducting powers of the substances concerned, and on the quantity of electricity, as distinguished from its intensity. Iron is found to conduct 400 million times as well as pure water, and sea water 720 times as well: and the path, chosen by the electric fluid, depending on the nature of all the substances within its reach, an animal, not immediately situated in the circuit, will often be affected, on account of the facility with which animal substances in general conduct the fluid. The shock of a torpedo, producing a strong sensation, but incapable of being conveyed by a chain, was imitated by the effect of a weak charge of a very large battery: and an artificial torpedo of wood being made a part of the circuit, the shock diffused itself very perceptibly through the water in which it was placed; but the experiment succeeded better, when the instrument was made of wet leather, which conducts rather better than wood, the battery being more highly charged, in proportion to the increase of conducting power.

6. *An Account of the Meteorological Instruments used at the Royal Society's House.* *Phil. Trans.* 1776. P. 875. Of the thermometers it is observed, that they are adjusted by surrounding the tubes with wet cloths or with steam, and barely immersing the bulbs in the water; since a variation of two or three degrees will often occur, if these precautions are neglected. For the correction of the heights of barometers, we have Lord Charles Cavendish's table of the depression arising from capillary action. The variation computed was found to exhibit a deviation from the meridian 15' greater in the house of the Royal Society than in an open garden in Marlborough Street: there was also a mean error of about 7' in the indications of the dipping needle; but it was difficult to ascertain the dip, without being liable to an irregularity, which often amounted to twice as much.

7. *Report of the Committee appointed to consider of the best Method of adjusting Thermometers.* *Phil. Trans.* 1777. P. 816. This paper is signed by Mr Cavendish and six other members, but it is principally a continuation of the preceding. It contains very accurate rules for the determination of the boiling point, and tables for the correction of unavoidable deviations from them: establishing 29.8 inches as the proper height of the barometer for making the experiment, if only steam be employed, and 29.5 if the ball be dipped in the water: but with all precautions, occasional variations of half a degree were found in the results.

8. *An Account of a New Eudiometer.* *Phil. Trans.* 1783. P. 106. Mr Cavendish was aware of the great difference in the results of eudiometrical experiments with nitrous gas, or nitric oxyd, according to the different modes of mixing the elastic fluids; and he justly attributes them to the different degrees of oxygenization of the acid that is formed. But he found that when the method employed was the same, the results were perfectly uniform; and he ascertained in this manner that there was no sensible difference in the constituent parts of the atmosphere under circumstances the most dissimilar: the air of London, with all its fices burning in the winter, ap-

Cavendish peering equally pure with the freshest breezes of the country. He also observed the utility of the sulfurets of potass and of iron for procuring phlogisticated air; but he does not seem to have employed them as tests of the quantity of this gas contained in a given mixture.

9. *Observations on Mr Hutchins's Experiments for determining the degree of Cold at which Quicksilver freezes. Phil. Trans. 1783. P. 303.* In experiments of this kind, many precautions are necessary, principally on account of the contraction of the metal at the time of its congelation, which was found to amount to about $\frac{1}{4}$ of its bulk; and the results which had been obtained, were also found to require some corrections for the errors of the scales, which reduced the degree of cold observed to 39° below the zero of Fahrenheit, or 71° below the freezing point, answering to -89.4° of the centesimal scale. In speaking of the evolution of heat during congelation, he calls it "generated" by the substances, and observes, in a note, that Dr Black's hypothesis of capacities depends "on the supposition that the heat of bodies is owing to their containing more or less of a substance called the matter of heat; and as" he thinks "Sir Isaac Newton's opinion, that heat consists in the internal motion of the particles of bodies, much the most probable," he chooses "to use the expression heat is generated," in order to avoid the appearance of adopting the mere modern hypothesis; and this persuasion, of the nonexistence of elementary heat, he repeats in his next paper. It is remarkable that one of the first of Sir Humphry Davy's objects, at the very beginning of his singularly brilliant career of refined investigation and fortunate discovery, was the confirmation of this almost forgotten opinion of Mr Cavendish; and for this purpose he devised the very ingenious experiment of melting two pieces of ice by their mutual friction in a room below the freezing temperature, which is certainly incompatible with the common doctrine of caloric, unless we admit that caloric could have existed in the neighbouring bodies in the form of cold, or of something else that could be converted into caloric by the operation; and this transmutation would still be nearly synonymous with generation, in the sense here intended. However this may be, it is certain that, notwithstanding all the experiments of Count Rumford, Dr Haldat, and others, Sir Humphry has been less successful in persuading his contemporaries of the truth of Mr Cavendish's doctrine of heat, than in establishing the probability of his opinions respecting the muriatic acid.

10. *Experiments on Air. Phil. Trans. 1784. P. 119.* This paper contains an account of two of the greatest discoveries in chemistry that have ever yet been made public: the composition of water, and that of the nitric acid. The author first establishes the radical difference of hydrogen from nitrogen or azote; he then proceeds to relate his experiments on the combustion of hydrogen with oxygen, which had partly been suggested by a cursory observation of Mr Warltire, a Lecturer on Natural Philosophy, and which proved that pure water is the result of the process, provided that no nitrogen be present. These experiments were first made in 1781, and were then

mentioned to Dr Priestley; and when they were first communicated to Lavoisier, he found some difficulty in believing them to be accurate. The second series of experiments demonstrates, that when phlogisticated air, or nitrogen, is present, in the process, some nitric acid is produced; and that this acid may be obtained from atmospheric air, by the repeated operation of the electrical spark.

It has been supposed by one of Mr Cavendish's biographers, that if Mr Kirwan, instead of opposing, had adopted his chemical opinions, "he would never have been obliged to yield to his French antagonists, and the antiphlogistic theory would never have gained ground." But in this supposition there seems to be a little of national prejudice. Mr Cavendish by no means dissented from the whole of the antiphlogistic theory: and in this paper, he has quoted Lavoisier and Scheele in terms of approbation, as having suggested the opinion "that dephlogisticated and phlogisticated air are quite distinct substances, and not differing only in their degree of phlogistication, and that common air is a mixture of the two." He afterwards mentions several memoirs of Lavoisier in which phlogiston is entirely discarded; and says that "not only the foregoing experiments, but most other phenomena of nature, seem explicable as well, or nearly as well, upon this, as upon the commonly believed principle of phlogiston;" and after stating a slight conjectural objection, derived from the chemical constitution of vegetables, he proceeds finally to observe, that "Lavoisier endeavours to prove, that dephlogisticated air is the acidifying principle;" this is no more than saying, that acids lose their acidity by uniting to phlogiston, which, with regard to the nitrous, vitriolic, phosphoric, and arsenical acids, is certainly true; and probably with regard to the acid of sugar; "but as to the marine acid, and acid of tartar, it does not appear that they are capable of losing their acidity by any union with phlogiston;" and the acids of sugar and tartar become even less acid by a further dephlogistication. It is obvious that this argument amounts only to an exception, and not to a total denial of the truth of the theory: M. Cuvier has even asserted that the antiphlogistic theory derived its first origin from one great discovery of Mr Cavendish, that of the nature of hydrogen gas, and owed its complete establishment to another, that of the composition of water: but it would be unjust to deny to Lavoisier the merit of considerable originality in his doctrines respecting the combinations of oxygen; and however he may have been partly anticipated by Hooke and Mayow, it was certainly from him that the modern English chemists immediately derived the true knowledge of the constitution of the atmosphere, which they did not admit without some hesitation, but which they did ultimately admit, when they found the evidence irresistible. On the other hand, it has been sufficiently established, since Mr Cavendish's death, by the enlightened researches of the most original of all chemists, that Lavoisier had carried his generalization too far; and it must ever be remembered, to the honour of Mr Cavendish, and to the credit of this country, that we had not all been seduced, by the dazzling semblance of

Cavendish. universal laws, to admit facts as demonstrated, which were only made plausible by a slight and imperfect analogy.

11. *Answer to Mr Kirwan's Remarks upon the Experiments on Air.* *Phil. Trans.* 1784. P. 170. Mr Kirwan, relying on the results of some inaccurate experiments, had objected to those conclusions, which form the principal basis of the antiphlogistic theory. Mr Cavendish repeated such of these experiments as seemed to be the most ambiguous, and repelled the objections: showing, in particular, that when fixed air was derived from the combustion of iron, it was only to be referred to the plumbago, shown by Bergmann to exist in it, which was well known to be capable, in common with other carbonaceous substances, of affording fixed air.

12. *Experiments on Air.* *Phil. Trans.* 1785. P. 372. The discovery of the composition of the nitric acid is here further established; and it is shown that the whole, or very nearly the whole of the irrespirable part of the atmosphere is convertible into this acid, when mixed with oxygen, and subjected to the operation of the electric spark: the fixed air, sometimes obtained during the process, being wholly dependent on the presence of some organic substances.

13. *An account of Experiments made by Mr John Macnab, at Henley House, Hudson's Bay, relating to Freezing Mixtures.* *Phil. Trans.* 1786. P. 241. From these experiments Mr Cavendish infers the existence of two distinct species of congelation in mixed liquids, which he calls the Aqueous and Spirituous Congelations, and of several alternations of easy and difficult congelation when the strength is varied, both in the case of the mineral acids and of spirit of wine. The greatest degree of cold obtained was $-78\frac{1}{2}^{\circ}$.

14. *An account of Experiments made by Mr John Macnab, at Albany Fort, Hudson's Bay.* *Phil. Trans.* 1788. P. 166. The points of easy congelation are still further investigated, and illustrated by comparison with Mr Keir's experiments on the sulfuric acid. It was found that the nitric acid was only liable to the aqueous congelation, unless it was strong enough to dissolve $\frac{1}{4}$ th of its weight of marble; and that it had a point of easy congelation, when it was capable of dissolving $\frac{1}{100}$ th, the frozen part exhibiting, in other cases, a tendency to approach to this standard. Mr Keir had found that sulfuric acid, of the specific gravity 1.78, froze at 46° ; and that it had another maximum when it was very highly concentrated.

15. *On the Conversion of a Mixture of Dephlogisticated and Phlogisticated Air into Nitrous Acid, by the Electric Shock.* *Phil. Trans.* 1788. P. 261. Some difficulties having occurred to the Continental chemists in the repetition of this experiment, it was exhibited with perfect success, by Mr Gilpin, to a number of witnesses. This was an instance of condensation, which could scarcely have been expected from the complete conviction, which the author of the discovery must have felt, of his own accuracy, and of the necessity of the establishment of his discovery, when time should have been afforded for its examination.

16. *On the Height of the Luminous Arch, which was seen on Feb. 23. 1784.* *Phil. Trans.* 1790. P. 101.

Mr Cavendish conjectures that the appearance of such arches depends on a diffused light, resembling the aurora borealis, spread into a flattened space, contained between two planes nearly vertical, and only visible in the direction of its breadth: so that they are never seen at places far remote from the direction of the surface; and hence it is difficult to procure observations sufficiently accurate for determining their height, upon so short a base: but in the present instance there is reason to believe that the height must have been between 52 and 71 miles.

17. *On the Civil Year of the Hindoos, and its Divisions, with an Account of three Almanacs belonging to Charles Wilkins, Esq.* *Phil. Trans.* 1792. P. 388. The subject of this paper is more intricate than generally interesting; but it may serve as a specimen of the diligence which the author employed in the investigation of every point more or less immediately connected with his favourite objects. The month of the Hindoos is lunar in its duration, but solar in its commencement; and its periods are extremely complicated, and often different for different geographical situations: the day is divided and subdivided sexagesimally. The date of the year, in the epoch of the Kalee Yug, expresses the ordinal number of years elapsed, as it is usual with our astronomers to reckon their days: so that the year 100 would be the beginning of the second century, and not the 100th year, or the end of the first century, as in the European calendar: in the same manner as, in astronomical language, 1817 December 31d. 18h. means six o'clock in the morning of the 1st of January 1818.

18. *Experiments to determine the Density of the Earth.* *Phil. Trans.* 1798. P. 469. The apparatus, with which this highly important investigation was conducted, had been invented and constructed many years before by the Reverend John Michell, who did not live to perform the experiments for which he intended it. Mr Cavendish, however, by the accuracy and perseverance with which he carried on a course of observations of so delicate a nature, as well as by the skill and judgment with which he obviated the many unforeseen difficulties that occurred in its progress, and determined the corrections of various kinds which it was necessary to apply to the results, has deserved no less gratitude from the cultivators of astronomy and geography, than if the idea had originally been his own. The method employed was to suspend, by a vertical wire, a horizontal bar, having a leaden ball at each end; to determine the magnitude of the force of torsion by the time occupied in the lateral vibrations of the bar; and to measure the extent of the change produced in its situation by the attraction of two large masses of lead, placed on opposite sides of the case containing the apparatus, so that this attraction might be compared with the weight of the balls, or, in other words, with the attraction of the earth. In this manner the mean density of the earth was found to be $5\frac{1}{2}$ times as great as that of water; and although this is considerably more than had been inferred from Dr Maskelyne's observations on the attraction

Cavendish. tion of Shehallion, yet the experiments agree so well with each other, that we can scarcely suppose any material error to have affected them. Mr Michell's apparatus resembled that which M. Coulomb had employed in his experiments on magnetism, but he appears to have invented it before the publication of M. Coulomb's Memoirs.

19. *On an Improved Method of Dividing Astronomical Instruments.* *Phil. Trans.* 1809. P. 221. The merits of this improvement have not been very highly appreciated by those who are in the habit of executing the divisions of circular arcs. It consists in a mode of employing a microscope, with its cross wires, as a substitute for one of the points of a beam compass, while another point draws a faint line on the face of the instrument in the usual manner. The Duke de Chaulnes had before used microscopical sights for dividing circles; but his method more nearly resembled that which has been brought forwards in an improved form by Captain Hater; and Mr Cavendish, by using a single microscope only, seems to have sacrificed some advantages which the other methods appear to possess: but none of them has been very fairly tried; and our artists have hitherto continued to adhere to the modes which they had previously adopted, and which it would perhaps have been difficult for them to abandon, even if they had been convinced of the advantages to be gained by some partial improvements.

Such were the diversified labours of a philosopher, who possessed a clearness of comprehension, and an acuteness of reasoning, which had been the lot of very few of his predecessors since the days of Newton. Maclaurin and Waring, perhaps also Stirling and Landen were incomparably greater mathematicians; but none of them attempted to employ their powers of investigation in the pursuit of physical discovery: Euler and Lagrange, on the Continent, had carried the improvements of analytical reasoning to an unparalleled extent, and they both, as well as Daniel Bernoulli and D'Alembert, applied these powers with marked success to the solution of a great variety of problems in mechanics and in astronomy: but they made no experimental discoveries of importance: and the splendid career of chemical investigation, which has since been pursued with a degree of success so unprecedented in history, may be said to have been first laid open to mankind by the labours of Mr Cavendish: although the further discoveries of Priestley, Scheele, and Lavoisier, soon furnished, in rapid succession, a superstructure commensurate to the extent of the foundations so happily laid. "Whatever the sciences revealed to Mr Cavendish," says Cuvier, "appeared always to exhibit something of the sublime and the marvellous: he weighed the earth: he rendered the air navigable: he deprived water of the quality of an element:" and he denied to fire the character of a substance. "The clearness of the evidence on which he established his discoveries, so new and so unexpected as they were, is still more astonishing than the facts themselves which he detected: and the works, in which he has made them public, are so many masterpieces of sagacity and of methodical reasoning: each perfect as a whole and in its parts; and leaving nothing for any other hand to correct; but rising in splen-

VOL. II. PART II.

Cavendish. dour with each successive year that passes over them; and promising to carry down his name to a posterity far more remote than his rank and connections could ever have enabled him to attain without them."

In his manners Mr Cavendish had the appearance of a quickness and sensibility almost morbid, united to a slight hesitation in his speech, which seems to have depended more on the constitution of his mind, than on any deficiency of his organic powers, and to an air of timidity and reserve, which sometimes afforded a contrast, almost ludicrous, to the sentiments of profound respect which were professed by those with whom he conversed. It is not impossible that he may have been indebted to his love of severe study, not only for the decided superiority of his faculties to those of the generality of mankind, but even for his exemption from absolute eccentricity of character. His person was tall, and rather thin: his dress was singularly uniform, although sometimes a little neglected. His pursuits were seldom interrupted by indisposition; but he suffered occasionally from calculous complaints. His retired habits of life, and his disregard of popular opinion, appear to have lessened the notoriety which might otherwise have attached to his multiplied successes in science; but his merits were more generally understood on the Continent than in this country; although it was not till he had passed the age of seventy, that he was made one of the eight Foreign Associates of the Institute of France.

Mr Cavendish was no less remarkable in the latter part of his life, for the immense accumulation of his pecuniary property, than for his intellectual and scientific treasures. His father died in 1783; being at that time eighty years old, and the senior member of the Royal Society: but he is said to have succeeded at an earlier period to a considerable inheritance left him by one of his uncles. He principally resided at Clapham Common; but his library was latterly at his house in Bedford Square; and his books were at the command of all men of letters, either personally known to him, or recommended by his friends: indeed the whole arrangement was so impartially methodical, that he never took down a book for his own use, without entering it in the loan book; and after the death of a German gentleman, who had been his librarian, he appointed a day on which he attended in person every week for the accommodation of the few, who thought themselves justified in applying to him for such books as they wished to consult. He was constantly present at the meetings of the Royal Society, as well as at the conversations held at the house of the President; and he dined every Thursday with the club composed of its members. He had little intercourse with general society, or even with his own family, and saw only once a year the person whom he had made his principal heir. He is said to have assisted several young men, whose talents recommended them to his notice, in obtaining establishments in life; but in his later years, such instances were certainly very rare. His tastes and his pleasures do not seem to have been in unison with those, which are best adapted to the generality of mankind; and amidst the abundance of all the means of acquiring every earthly enjoyment, he must have wanted that sympathy, which alone is capable of redoubling our delights, by the consciousness

4 Q

Cavendish. that we share them in common with a multitude of our friends, and of enhancing the beauties of all the bright prospects that surround us, when they are still more highly embellished by reflection "from looks that we love." He could have had no limitation either of comfort or of luxury, to stimulate him to exertion; even his riches must have deprived him of the gratification of believing, that each new triumph in science might promote the attainment of some great object in life that he earnestly desired; a gratification generally indeed illusory, but which does not cease to beguile us till we become callous as well to the pleasures as to the sorrows of existence. But in the midst of this "painful preeminence," he must still have been capable of extending his sensibility over a still wider field of time and space, and of looking forwards to the approbation of the wise and the good of all countries and of all ages: and he must have enjoyed the highest and purest of all intellectual pleasures, arising from the consciousness of his own excellence, and from the certainty that, sooner or later, all mankind must acknowledge his claim to their profoundest respect and highest veneration.

"It was probably either the reserve of his manners," says Cuvier, "or the modest tone of his writings, that procured him the uncommon distinction of never having his repose disturbed either by jealousy or by criticism. Like his great countryman Newton, whom he resembled in so many other respects, he died full of years and honours, beloved even by his rivals, respected by the age which he had enlightened, celebrated throughout the scientific world, and exhibiting to mankind a perfect model of what a man of science ought to be, and a splendid example of that success, which is so eagerly sought, but so seldom obtained." The last words that he uttered were characteristic of his unalterable love of method and subordination: he had ordered his servant to leave him, and not to return till a certain hour, intending to pass his latest moments in the tranquillity of perfect solitude: but the servant's impatience to watch his master diligently having induced him to infringe the order, he was severely reprimanded for his indiscretion, and took care not to repeat the offence, until the scene was finally closed. Mr Cavendish died on the 24th of February 1810; and was buried in the family vault at Derby. He left a property in the funds of about L.700,000, which he divided into six equal parts, giving two to Lord George Cavendish, the son of his first cousin, one to each of his sons, and one to the Earl of Bessborough, whose mother was also his first cousin. Some other personal property devolved to Lord George as residuary legatee; and a landed estate of L.6000 a year descended to his only brother, Mr Frederic Cavendish of Market Street, Herts, a single man, and of habits of life so peculiarly retired, that any further increase of income would have been still more useless to him than it had been to the testator.

Much as Mr Cavendish effected for the promotion of physical science throughout his life; it has not been unusual, even for his warmest admirers, to express some regret that he did not attempt to do still more after his death, by the appropriation of a small share of his immense and neglected wealth, to the

perpetual encouragement of those objects, which he *Cavendish* had himself pursued with so much ardour. But however we might be disposed to lament such an omission, we have surely no reason to complain of his determination to follow more nearly the ordinary course of distribution of his property, among those whose relationship would have given them a legal claim to the succession, if he had not concerned himself in directing it. We may observe on many other occasions, that the most successful cultivators of science are not always the most strenuous promoters of it in others; as we often see the most ignorant persons, having been rendered sensible by experience of their own deficiencies, somewhat disposed to overrate the value of education, and to bestow more on the improvement of their children, than men of profounder learning, who may possibly have felt the insufficiency of their own accomplishments for insuring success in the world. But even if Mr Cavendish had been inclined to devote a large share of his property to the establishment of fellowships or professorships, for the incitement of men of talents to a more complete devotion of their lives to the pursuit of science, it is very doubtful whether he could have entertained a reasonable hope of benefiting his country by such an institution: for the highest motives that stimulate men to exertion are not those which are immediately connected with their pecuniary interests: the senators and the statesmen of Great Britain are only paid in glory; and where we seek to obtain the cooperation of the best educated and the most enlightened individuals in any pursuit or profession, we must hold out as incentives the possession of high celebrity and public respect; assured that they will be incomparably more effectual than any mercenary considerations, which are generally found to determine a crowd of commercial speculators to enter into competition for the proposed rewards, and to abandon all further concern with the objects intended to be pursued, as soon as their avarice is gratified. To raise the rank of science in civil life is therefore most essentially to promote its progress: and when we compare the state not only of the scientific associations, but also of the learned professions in this country and among our neighbours, we shall feel little reason to regret the total want of pecuniary patronage that is remarkable in Great Britain, with respect to every independent department of letters, while it is so amply compensated by the greater degree of credit and respectability attached to the possession of successful talent. It must not however be denied, that even in this point of view there might be some improvement in the public spirit of the country: Mr Cavendish was indeed neither fond of giving nor of receiving praise; and he was little disposed to enliven the intervals of his serious studies by the promotion of social or convivial cheerfulness: but it would at all times be very easy for an individual, possessed of high rank and ample fortune, of correct taste and elegant manners, to confer so much dignity on science and literature by showing personal testimonies of respect to acknowledged merit, as greatly to excite the laborious student to the unremitting exertions of patient application, and to rouse the man of brilliant talent to the noblest flights of genius.

Cavendish
Celebes.

Celebes
Cesarotti.

Gentleman's Magazine, 1810, ii. P. 188.—Aikin's *General Biography*, Vol. X.—Chalmers's *Biographical Dictionary*, Vol. VII.—Thomson's *Annals*, Vol. I.—Cuvier, *Histoire de la Classe des Sciences Mathématiques*, 1811. P. cxxvi. (L. 1.)

CELEBES, an extensive island in the Indian archipelago, situated between Java and Borneo, and extending from about 2° north, to 6° south latitude, and 119° to 125° east longitude. It is of the most irregular form, consisting of four long peninsulas, united together at a central point. It was first discovered by the Portuguese in 1525. In 1660, that people were driven out by the Dutch, who had to sustain a long series of contests with the natives, till, in 1699, they succeeded in forming a permanent settlement. Their principal establishment has always been Fort Rotterdam, at Macassar, on the western coast of the island, situated in 5° 9' south latitude, and 119° 48' east longitude. The fort is about 800 feet from the sea, well fortified with high and strong walls. The town lies on a plain to the north, and is tolerably built; the streets broad and crossing each other at right angles. The trade is not considerable, the country affording few articles of export except rice and a number of slaves for the supply of Java. The chief object of the Dutch in this settlement, was to secure their communication with the spice islands. They had repeated attacks to sustain from the Rajah of Macassar, whose power, in 1778, they finally subverted, and transferred the superiority to their ally, the Rajah of Bony. His territory is situated round the great bay on the southern coast, called the Bay of Bony, Sewa, or Ruggess. The inhabitants are termed Bonginese, or Bonnians, corrupted by the English into Buggesses. These are a very remarkable people, and possess many excellent qualities. In a manuscript account which we have seen, written by a gentleman long resident in this part of India, they are considered as by much the most meritorious of the inhabitants of the East India islands. They manufacture the cotton of their own country, and of Java, into a species of cloths, which, from their superior quality, are in universal demand throughout the archipelago. Their permanent residence he states to be around a great lake in the interior, which they leave at the commencement of the season favourable for navigation. They then sail down a river into the bay of Bony, whence they spread themselves over all the neighbouring seas. There is not a coast from the extremity of New Holland to the Malay peninsula, in which their prows are not habitually seen. Besides exchanging their own commodities for those of their neighbours, they act as carriers between the countries that lie remote from each other. Our informant describes their conduct as traders to be not less upright and honourable than it is active and enterprising. They defend themselves and their property against the attacks of the Malay pirates with the most heroic and desperate valour. Major Thorn, in his *Account of Java*, mentions an instance in which a Bonginese crew, being overcome and boarded, set fire to a barrel of powder which was on board, and thus blew up at once themselves and their assailants.

In 1814, the Rajah of Bony being considered inimical to the British Government, an expedition against him was sent from Java under General Nightingale. It arrived at Macassar on the 7th of June, and immediately landed. The British force, led by Col. Macleod, attacked the town and palace, and carried them in about an hour, though with some loss, the Rajah escaping into the interior of his dominions. A new government was then established; but the revolution in Europe has, we believe, restored this settlement to the Dutch, its former possessors.

The interior of Celebes, and the remainder of its coasts, are almost entirely unknown. The Great Bay of Gonong Tello, on the east coast, presents many natural advantages. Gold is exported from its coasts, and the amount is said to be capable of almost indefinite augmentation. Tortoise shell is likewise produced in considerable quantity. Bentham Bay, to the south-east of Macassar, has a fort with some trade: the country round produces excellent rice.

The exports are nearly similar to those of Borneo. Gold is found, as there, in alluvial soil, washed down by the rivers. Sometimes even springs, slightly impregnated with that metal, issue from the rocks. The total value of the gold exported is estimated by Mr Hamilton at L.120,000. (*East India Gazetteer*.) The cotton cloths manufactured in Celebes, called *cambays*, are universally worn through the Indian islands; but their use does not extend farther. The imports coincide precisely with those of Borneo. (B.)

CESAROTTI (MELCHIOR), an Italian poet, was born at Padua, in the year 1730, of a family of considerable rank but small fortune. He was educated at the academy of Padua, where he early showed a strong inclination for literary pursuits, and made such progress in study, that he was raised to the Chair of Rhetoric in the Academy where he had been brought up, at a period of life when others were yet attending the lectures. Having been appointed to this charge, he devoted himself with the utmost zeal to the duties of his situation. He introduced several useful reforms in the system of education which was then practised, and endeavoured by incessant study to render his instructions as useful as possible to the youth committed to his care. The first fruits of his studies were Italian translations of the Prometheus of Æschylus, and three Tragedies of Voltaire, the merit of which, and the reputation he had acquired for learning and persevering application, successively procured him a distinguished employment at Venice, and the Professorship of Greek and Hebrew in the University of Padua. Cesarotti had held this situation for nearly thirty years at the date of the first French invasion of Italy. This poet did not, like Alfieri, scorn the pecuniary favours of the republican government, nor shun the acquaintance of its chiefs. He published several political tracts and essays by their order; and when the general of the invading army assumed the title of King of Italy, he was rewarded with two pensions of considerable amount, and distinguished

Cesarotti.

by various honours. He continued to reside partly at Padua, and partly at his country house of Selvaggiano, chiefly occupied with the composition of laudatory poems in return for the favours he had received, and with the superintendence of a complete edition of his works, when he was suddenly arrested by the hand of death on the 3d of November 1808.

Though held by Sismondi to be the first in point of celebrity of the modern Italian poets, Cesarotti is better known as a translator than an original author. The Italians have always been distinguished for the elegance and spirit of their translations from the classics; the Lucretius of Marchetti, the Æneid of Annibal Caro, and Anguillara's free version of the Metamorphoses of Ovid have deservedly exalted their reputation to the utmost height in this department of literature. Anguillara's translation of Homer, however, had been less popular and successful than his Metamorphoses, and there still remained room in Italy for a translation of the Prince of poets. The work, however, of Cesarotti, is far from being literal; he has modernized and accommodated the Iliad to the prevailing taste of the age; he has abridged it in some places, and added to it in others, according to his taste or fancy; and he has been often reproached with having given to the Greek bard the style and language of his favourite Ossian. In the late edition of the works of Cesarotti, the poetical version is followed by a literal prose one, accompanied with critical notes and dissertations, partly translated from Pope and Dacier.

Cesarotti acquired more fame by his version of Ossian than of Homer; and certainly no translation had ever more appearance of originality and inspiration. He has completely preserved the spirit of the supposed bard of Morven—his gigantic and gloomy grandeur; and, at the same time, has given us that harmony of versification, which we miss in the work of Macpherson. The Italian Ossian was first published at Padua in 1763, 2 vols. 8vo, at the expence of an English traveller, with whom Cesarotti had contracted a friendship. This edition was necessarily incomplete, as the translation of Macpherson at that time was so also; but the whole poems were printed at the same place about ten years afterwards in 4 vols. small 8vo. The *Poems* of Ossian also occupy four volumes in the recent complete edition of the works of Cesarotti, where they are accompanied by an examination of the question so much agitated in this country, with regard to the authenticity of these celebrated productions. Their appearance in this new form attracted much attention in Italy, and raised up many imitators of the Ossianic style, so different from the warm and glowing imagery of the earlier Italian poets.

His country was also indebted to Cesarotti for a number of valuable prose works. The *Course of Greek literature* was his chief undertaking; but the plan on which he had commenced was too vast to be completed. His *Essays on the Sources of the pleasure derived from Tragedy*, and on the *Origin and Progress of the Poetic Art*, are distinguished by elegant and ingenious criticism; while his treatises *Sulla Filosofia delle Lingue, et Sulla Filosofia de*

Gusto (the last of which is principally intended as an apology for the peculiarities of his own style), show considerable acuteness and strength of understanding. In 1797, an Academy of Sciences and *Belles Lettres* had been established at Padua, of which Cesarotti was nominated perpetual Secretary. It was part of the duties of this situation to read at the stated meetings of the Academy the various essays which had been prepared by its members. Frequently, however, these were of such extent, that the Secretary found it expedient merely to give, in his own language, a general account of the object of the author, and the result of his investigations. These readings produced his Reports, entitled *Relazioni Accademiche*, each of which reports is divided into three parts; the first containing the Essays on Experimental Philosophy, the second on Mathematics, and the third on *Belles Lettres*. The whole, however, may be regarded as a literary composition, since the departments of mathematics and philosophy exhibit only general views of the subjects of inquiry. Almost all the prose works of Cesarotti are distinguished by extensive erudition and a philosophical spirit, while his style is lively and forcible. But the Italian prose of the eighteenth century was very different from that written by Giovanni Della Casa, Machiavel, and their contemporaries in the sixteenth; and those critics, who have deplored the recent innovations on the ancient purity of the Tuscan tongue, chiefly attribute to Cesarotti the introduction of those Gallicisms and new modes of expression, which have corrupted the language of the golden age of Leo.

All the works of Cesarotti above mentioned, including several volumes of correspondence, have been published in a complete edition, which was commenced at Padua in the year 1800, under the author's own direction. It has been continued since his death by Joseph Barbieri, who was his successor in the chair of Greek and Hebrew at Padua, and who has also published *Memoirs* of the Life and Writings of his deceased friend, printed at Padua, 1810, 8vo.

It has been the fate of most literary men to be ranked either higher or lower by their own age than by posterity. Cesarotti will probably belong to the former class, who, perhaps after all, enjoy the pleasanter sort of reputation. But, though the praise of great and original genius may in future times be denied him, every age will admit his learning and talents, and the meritorious assiduity of his literary researches. (M.)

CEYLON. In the *Encyclopædia* the reader will find a description of this island and its more remarkable productions; with a short summary of its history, down to the year 1796, when the maritime provinces, then in possession of the Dutch, were conquered by the arms of Britain. We now propose to continue the historical sketch to the present time; and to add such details relative to the population, productions, trade, and commerce of the island, as recent information enables us to supply. The conquered provinces remained, for a short time, as an appendage to the presidency of Madras; but were afterwards rendered independent of the East India Company, and annexed to the Crown of

Ceylon. Great Britain. In the year 1798, the King of Candy died, and the Crown was transferred, by the intrigues of Pōlemé Talavé, the Chief Adigar, or Prime-Minister, to a young Malabar, without birth, talents, or pretensions of any kind. The policy of the Adigar was decidedly hostile to the British Government; and his object was to amuse them with delusive negotiations, while he awaited a favourable opportunity for expelling them from the island. After some time spent in secret preparations for war, hostilities were at length provoked by the aggressions of the Candians, in the spring of 1802; and two divisions of the British forces were in consequence moved into the interior, from Columbo and Trincomalee, under Major-General Macdowall and Colonel Barbut. They experienced very little resistance on their march, and the two divisions formed a junction at Candy. The city, however, was found entirely deserted by the Government and inhabitants, and had been set on fire in several places. The King had removed all his treasure, and the inhabitants had carried away or destroyed everything valuable. Mootto Sawmy, the brother of the late Queen, was now removed to Candy, and placed by the British troops upon the throne; but the people of authority in the neighbouring country showed no disposition to submit to his sway. The plan of the Chief Adigar appears to have been, to draw the British troops by detachments farther into the country, and then to cut off their retreat. This design he endeavoured to execute by means of the most profound and systematic dissimulation and treachery. Having lulled the British officers into a delusive security, by the conclusion of a treaty, which was intended only for deception, a great part of the troops were withdrawn from Candy, where they had begun to suffer from the sickness of the rainy season, and a small garrison was left in the palace, under the command of Major Davie. The Candians, perceiving the success of their treachery, drew their lines nearer to the city, and entrenched themselves in strong positions in the immediate vicinity. In the mean time, the garrison daily decreased, in consequence of death and desertion; and Major Davie, at length, found himself under the necessity of submitting to a humiliating capitulation, the terms of which were only observed by the Candians, until they had got their enemies completely into their power, when the whole detachment were wantonly and perfidiously massacred.

Elated with this success, the King of Candy now began to entertain hopes of the total expulsion of the British from the island; and a war of ravage and spoliation was carried on for some time, which is remarkable only for the barbarity with which it was conducted on both sides. The repeated invasions of the Candians, however, were uniformly repulsed with great loss; and hostilities were, at length, suspended by a sort of tacit consent, originating, probably, from the weakness of the enemy, and the pacific disposition of the British administration. Meanwhile, the many acts of tyranny and arbitrary cruelty which had been exercised by the Candian monarch, justly rendered him odious to his

Ceylon. own subjects; and a most barbarous outrage, committed upon some unoffending inhabitants of the English settlements, at last called forth the full and final vengeance of the British government. The war, which ensued in 1815, was short, and attended with the most decisive results. The capital was taken; the King made prisoner and deposed; and a grand convention having been held of the British authorities and the Candian chiefs, a treaty was proposed and ratified, by which the dominion of the whole Island of Ceylon was vested in the Sovereign of Great Britain.

From monuments still existing in Ceylon, this Population. island evidently appears to have been much more populous, and much better cultivated, in former times, than at present. We have no accurate data, indeed, from which we can form an estimate of the precise amount of the actual population of Ceylon, but it probably does not exceed one million and an half. The inhabitants may be divided into four distinct tribes or nations, viz. the Ceylonese proper, who occupy the territories formerly belonging to the King of Candy, and the south and south-west coasts; the Malabars or Hindoos, who possess the north and east coasts, and the peninsula of Jaffnapatam; the Moors, who are dispersed over every part of the island, and who may be considered as the most industrious portion of the population; and the Vedas or Bedas, who appear to be the only indigenous tribe in the island, living in a savage state in the large forest which extends from the south to the east and north, upon the borders of our old limits, and into the Candian territory. Mr Percival and Mr Cor diner make a distinction between the Ceylonese and the Candians; but according to the latest and best authorities, referred to at the end of this article, they seem to be one and the same nation; having the same origin, language, religion, and habits. The population has been rapidly increasing for some years, owing principally to the introduction of vaccination, which has been generally practised, and with great success; insomuch, that the small-pox, which formerly committed great ravages in Ceylon, has now been wholly expelled from the island. This increasing population, however, is far from being in a prosperous condition, as, for some years past, it has pressed hard upon the means of subsistence. The distress was much aggravated in the years 1812, 1813, and 1814, by repeated droughts, which proved injurious to the cultivation of rice; while, in consequence of the superabundant population, the price of labour, during this great scarcity, continued at the same low rate as formerly. The territory within the old limits of the British government, does not produce a sufficient quantity of rice for the maintenance of its own inhabitants; much of that necessary article has been, at all times, imported from the coasts of Malabar and Coromandel, and from Bengal; and a very large supply was derived from the Candian country, which produced a considerable surplus. But as the population of these districts is also upon the increase, the supply derived from that source has necessarily suffered a proportional diminution.

The principal towns on the island are Candy, Co-Chief Towns.

Ceylon. lumbo, Point de Galle, and Trincomalee. Of these, Columbo and Trincomalee, which are situated within the old British territory, have been already described in the body of this work. The town of Candy was the native capital, previous to the entire conquest of the island. It is situated in the province of Tallanour, in the midst of lofty mountains covered with thick jungle; and the passes to it are narrow, and intersected with close hedges of thorn. The town itself is mean, and surrounded by a mud wall of no strength. Its length is about two miles; and it consists of one broad street, with numerous lanes branching from the principal thoroughfares. The houses are chiefly of mud, thatched with straw and leaves, with small apertures instead of windows. At one end of the great street stands the palace, an immense pile of building, constructed of stone and wood, and covered over with a species of white cement. It comprehends within its walls two temples dedicated to Boodh, or Buddhu,—one Hindoo pagoda,—the cemetery of the Kings of Candy,—and a great variety of arsenals and storehouses. The surrounding scenery is rich and beautiful. The land in the neighbourhood is highly cultivated, and interspersed with villages and rivulets. Some of the mountains are cleared to their summits, formed into ridges, and sown with grain; the valleys are fertilized by assiduous and skilful irrigation, and are clothed with areca, jack, cocoa-nut, and other trees, and with fields of paddy and other grain.

Point de Galle.

Point de Galle, the only other town of which it seems necessary to give a description, is situated at the southern extremity of the island, on a low rocky promontory, backed by several ranges of hills, rising above one another, and covered with wood. The fort, in which most of the Europeans reside, is more than a mile in circumference, and contains a variety of large and commodious habitations. Europeans are here much less incommoded by the heat than in other parts of India; for although the town is situated within less than six degrees of the equator, the temperature is frequently as low as 72° of Fahrenheit, and never exceeds 86°. The disease, called Elephantiasis, is said to prevail a good deal among the poor residents at Point de Galle, and is ascribed to bad water and insufficient nourishment.

Character of the Ceylonese.

It seems difficult to give a faithful delineation of the character of the Ceylonese. In general, they are mild in their manners, and reserved in their address; not easily roused to resentment and bloodshed, yet proceeding with extraordinary determination in the prosecution of their object, when acting under the impulse of passion. Crimes of the deepest dye have occasionally been perpetrated among the lower castes; but the conduct of the better castes is generally correct and decorous. They are consummate masters of the art of insinuating themselves into the good opinion and favour of their superiors; and they possess a wonderful degree of address in working upon the feelings of others, while they can keep themselves free from every emotion.

Religion.

The religion of the Ceylonese consists in the worship of Boodh, which is also established in the Birman empire, and in the kingdom of Siam. This religion lays claim to great antiquity, and appears to have

existed prior to the Braminical system; although the Ceylonese learned are not agreed concerning the age of Boodh, or Buddhu, or the country in which his religious doctrines were first promulgated. According to the mythology of the Ceylonese, this personage, whose footstep is still to be seen on the top of Adam's Peak, is said to have descended upon earth, and, after having performed a vast number of virtuous actions, and been transformed into a great variety of shapes, to have again ascended into heaven, where he acts as a mediator with the Supreme Being, and procures the pardon of his worshippers. Although the Ceylonese acknowledge the existence of one Supreme Being, yet they dedicate no temples to his worship; those of Buddhu being superior to all others. Buddhu is said to have always worn a yellow dress; and for this reason his priests still wear a dress of a similar colour; and his images, in the temples, are invariably yellow from the head to the feet. The religious kalendar of the Ceylonese comprehends seven other saints or subordinate deities, to each of whom they erect images, and ascribe peculiar powers and prerogatives; but their worship is inferior to that of Buddhu. Some of the Ceylonese temples, or pagodas, are magnificent structures, indicating a much higher degree of excellence in the arts, in some former period, than the natives at present possess. Some of these pagodas are endowed with great revenues, and possess high privileges. The priests are divided into three ranks; of whom the highest order is set apart for the worship of Buddhu; the others minister to the worship of the inferior deities. The highest sacerdotal office is not compatible with any species of manual labour; and the priests, so long as they continue to exercise their functions, are doomed to the most rigorous celibacy. But, in the system of Buddhu, the priesthood does not constitute a peculiar caste; nor is the character indelible, as among the Brahmins; on the contrary, they are at liberty to renounce their sacred calling, and to resume their place among the laity.

Christianity was first introduced into Ceylon by the celebrated Francis Xavier, in the year 1452; and the Portuguese, so long as they exercised their sway over the maritime parts of the island, continued to prosecute the work of conversion by means of their priests. When the Dutch became masters of the coast, they endeavoured to substitute the reformed faith for that of the Church of Rome. In the year 1801, the number of native inhabitants, who professed the Protestant faith, was calculated to exceed 342,000; while those of the Romish communion were reckoned to be still more numerous. In 1805, some missionaries were sent from England, for the purpose of instructing the Ceylonese in the principles of Christianity; and it is thought that the propagation of this doctrine would experience much fewer obstacles in this island than in Hindostan. In Ceylon, the rites of the ancient religion are said to be almost totally forgotten; and the inhabitants, more ignorant than bigotted, and more simple than prejudiced, would the more readily admit any religious impressions, which a devout teacher might make upon their minds.

A most excellent institution of the Dutch, and School

Ceylon. which redounds highly to their honour and liberality, consisted in the establishment of schools, for the instruction of the natives in the elements of useful knowledge, and in the principles of Christianity. These schools, of which one is erected in every parish, appear to have been placcd under very judicious regulations. They continued to flourish under the Dutch; but when the English obtained possession of the island in 1796, the salaries of the masters had been left unpaid for about three years, and the schools, consequently, fell into decay. The Hon. Mr North, who became Governor of the island towards the end of the year 1798, spared no pains to re-establish them; and, under his auspices, they were increased in number, improved in management, and augmented in usefulness. But the liberal views and salutary arrangements of this enlightened gentleman were unfortunately counteracted, in a great measure, by the ill-judged parsimony of the British Government, who, in the year 1803, limited the annual allowance for the schools to the sum of L. 1500, although the whole saving was paltry, when weighed against the many and important advantages resulting from these beneficial establishments.

Agriculture and Manufactures.

The agriculture and manufactures of Ceylon are at present by no means in a flourishing state. This is chiefly owing to a want of capital; yet the obstacles which now exist might be removed, in a great measure, by proper encouragement, and a judicious direction of the industry of the inhabitants. The soil is rich and fertile, but great part of it is left waste; insomuch that the land does not at present produce the first necessaries of life in sufficient quantity to supply the wants of the population. Cotton has been ascertained to grow with the greatest facility, and to produce abundantly. The Nankin, Bourbon, and Brazil cottons have all been found to succeed; yet there has been hardly any cotton reared hitherto; and even the commonest cloths, for the use of the natives, are imported from the continent of India.

Productions. Cinnamon.

The principal productions of Ceylon are, 1. The cinnamon, for which it has long been famous, and which has attracted the particular attention of the different European governments that have successively taken possession of the island. The cinnamon tree is indigenous to Ceylon, where it grows wild to a considerable size. The bark of the tree consists of two coats, or layers, of which the interior constitutes the true cinnamon. This bark, after being peeled off, is laid in the sun to dry, when it curls up into rolls, as we commonly see it. The finest cinnamon is that which is obtained from the younger and smaller trees; a coarser sort is derived from the trees of larger dimensions and greater age. The cinnamon is collected by a particular caste, called Challias, who, on this account, enjoy peculiar privileges. When the bundles or sacks of cinnamon are stowed on board the ships, black pepper is strewed over each layer, so as to fill up the interstices; and both commodities are said to be improved by this method of stowing. Formerly, the crop of cinnamon was collected in the forests and jungles, the greater part of the trees being within the terri-

teries of the king of Candy; but during the latter period of the Dutch government, attempts were made, and ultimately with complete success, to cultivate cinnamon in plantations; and to their exertions we are indebted for the present flourishing state of this article of commerce. According to a calculation made by the Dutch, the annual consumption of cinnamon was estimated at 400,000 lbs.—say 5000 bales, of 80 lbs. each. When the island was transferred from the English East India Company to an immediate administration under the Crown (January 1802), the government entered into a contract with the Company, by which the latter acquired the exclusive privilege of exporting that article from the colony. It was agreed that the Ceylon government should deliver annually 400,000 lbs. of cinnamon, making 4,324½ bales, each bale consisting of, within a small fraction, 92½ lbs.; for which the Company granted a credit of L.60,000, making the price of the cinnamon 3s. per lb. The Company farther became bound to give credit to the colony for the amount of all clear profits which it should make on that commodity, beyond five per cent. No cinnamon, therefore, can be sold or exported from Ceylon but by the Company, with the exception of what is rejected by their agent there. In the year 1806, the Company proposed that 450,000 lbs. should be delivered annually, at 2s. 6d. per lb. instead of 400,000, at 3s.; which the government agreed to; and this agreement remained in force until 1810, when the parties reverted to the former contract. In 1814, the Company agreed to allow to the Ceylon government a sum of L.200,000 Sterling for surplus profits on their sales of cinnamon; and to give, in future, L.101,000 Sterling annually, instead of L.60,000, for a supply of 400,000 lbs. of that commodity. This contract is understood to have been entered into for seven years. But, in adjusting the accounts, it will appear that a large deduction must be incurred by the colony, in consequence of having very seldom delivered the stipulated quantity.

Ceylon.

2. The cocoa-nut tree, which is perhaps the richest known in the world. Besides the nut, with its milk, this tree produces *mirra*,—a mild beverage, without acidity or powers of intoxication; *toddy*, from which the spirituous liquor called *arack* is distilled; cocoa-nut oil; the *jagery*, a kind of sugar, manufactured from the mirra; and the *coir*, from which ropes are made. The average quantity of arack exported annually from Ceylon may be stated at 5200 leagers, of 150 gallons each. The great markets for this article have hitherto been Madras and Bombay, with the Malabar and Coromandel coasts. Within the last three years, some hundreds of leagers have been brought to England, and sold from 5s. 6d. to 6s. 6d. per gallon. 3. The palmyra tree, which, after the cocoa-nut tree, is the richest plant in the east. It requires ten years before it bears fruit, but, as is asserted, it will continue doing so for 300 years. This tree contributes in many ways to feed the lower class of natives in Ceylon. The fruit, when green, affords a pleasant beverage; and, when ripe, a nourishing and wholesome food. Sometimes the juice of it is expressed, which har-

Ceylon. dens and is preserved for a long time, and is eaten by the natives in different ways. The shell and the fibres, after the juice is pressed out, form excellent fattening food for cattle; and if the fruit be put under ground for two or three months, it strikes strong roots, which are also good for the food of man. The value of the tree, when cut down, is from four to five rix-dollars; and the annual revenue drawn by government from the duties on the exportation of palmyra timber amounts to about 25,000 rix-dollars. 4. The *arrecá* nut is a very important article of Ceylon produce, being the best of the kind in India. The nuts are exported chiefly to the Coromandel and Malabar coasts; and the annual revenue derived by government from the duties on the exportation of this article may be stated at 125,000 rix-dollars. 5. Tobacco, which is cultivated in the district of Jafnapatam, of a peculiar quality, and prepared in a particular manner for chewing. 6. Ceylon produces various sorts of wood, of the finest and richest kinds, for cabinet-making. The scarcest and dearest is the *calamander*, of a hard and close grain, beautifully veined with different shades of black and brown. The *homander* greatly resembles it, but the veins are not so fine. The *ream* wood has also very beautiful veins of the same colours, but smaller and more regularly striped. The *jack-wood* very much resembles mahogany, and is used for the same purposes. The *ebony* and *satin* woods are well known. The *sappan* wood is a kind of log-wood, used for dyeing cotton-cloth of a fine red, or rather very deep orange colour. 7. The pearl-fishery has been particularly described in the *Encyclopædia*. 8. Ceylon is rich in precious stones. Of these the most valuable are, the *oriental sapphire*, *topaz*, *ruby*, *amethyst*, and *blue sapphire*; the *cat's-eye*, which is the finest known of that kind; the *tourmaline*, of every shade; the *amethyst*, which is superior in brilliancy to that of Brazil; the *cinnamon* stone; the *garnet*, and the *moon-stone*, which is a species of opal. Ceylon also produces the finest jet and crystal of different tinges. Pepper, coffee, and cardamom, are likewise cultivated in Ceylon; but these productions, it is said, are not indigenous, having been introduced by the Dutch, who also made unsuccessful attempts to rear the silk-worm, and cultivate the mulberry-tree.

Commerce. As there are no manufactures of any consequence, the commerce of the island consists in the exportation of its natural productions, and the importation chiefly of rice and other grain, and cloth. The following table will show the respective value of the whole exports and imports, during a period of five years, with the amount of the duties annually collected by Government. The sums are expressed in rix-dollars.

	Exports.	Imports.	Duties.	Ceylon.
1809,	2,660,795	2,635,236	440,327	
1810,	2,777,997	3,112,748	480,433	
1811,	2,781,633	3,574,313	461,495	
1812,	2,442,895	4,215,399	410,185	
1813,	2,443,940	6,378,739	408,819	

From this table it will appear that there is a considerable commercial balance against Ceylon. This is occasioned by the great annual importations of rice and cloth; and it might be removed by giving greater encouragement to the cultivation of grain, and by the introduction of cotton, and the manufacture of that article into clothing for the natives. For these purposes our new acquisitions are eminently adapted. The Candian territory has always produced more rice than was wanted by its inhabitants; and cotton grows most luxuriantly in the interior of Ceylon. Nothing, in short, is wanted but industry and capital to render Ceylon perfectly independent for food and clothing.

The relative amount of the revenue and expenditure of the Colonial Government, during the years 1811 and 1812, was as follows:

	Revenue.	Expenditure.
1811,	2,926,228 R.ds.	3,336,038 R.ds.
1812,	3,028,446	3,399,726

The balances constituted by the excess of the expenditure beyond the revenue have been covered by the issue of debentures; by the sums paid into the treasury by civil servants, for the civil fund, and borrowed by Government; by some balances that remained in favour of the Ceylon Government, in the hands of its agents at the presidencies of India; and by anticipating some of the public resources, which are understood to have been afterwards made good by the revenue of the pearl-fishery, in 1813. A considerable saving to the revenue might probably be effected by means of an improved method of collection, and by a diminution of the number of civil servants. But the greatest advantage would undoubtedly be derived from a well-directed attention to the improvement of the resources of this important colony, by stimulating the industry of its inhabitants, and encouraging the cultivation of its various articles of produce.—See Lord Valentia's *Travels*; *Asiatic Annual Register*; *The History of Ceylon*, by Philaethes, London, 1817; and particularly the following instructive work: *A View of the Agricultural, Commercial, and Financial Interests of Ceylon*, by Anthony Bertolacci, Esq. London, 1817. (B.)

CHEMICAL ANALYSIS. See DECOMPOSITION, CHEMICAL.

