This is a reproduction of a library book that was digitized by Google as part of an ongoing effort to preserve the information in books and make it universally accessible.

Google™ books

<https://books.google.com>



Feb. 9. 24.

JOURNAL
OF A
HORTICULTURAL TOUR.



8 C 2
JOURNAL

OF A

HORTICULTURAL TOUR

THROUGH SOME PARTS OF

FLANDERS, HOLLAND,

AND THE

NORTH OF FRANCE,

IN THE AUTUMN OF 1817.

BY A

DEPUTATION OF THE CALEDONIAN HORTICULTURAL
SOCIETY.

K. Neill P.

EDINBURGH :

PRINTED FOR BELL & BRADFUTE, EDINBURGH ;
AND FOR LONGMAN, HURST, REES, ORME & BROWN,
LONDON.

1823.

ANNALS

AND

RECORDS OF THE



P. NOLL, Printer.

PREFACE.

THE horticultural tour, an account of which is here presented to the Public, was first proposed, at the anniversary meeting of the Caledonian Horticultural Society in September 1815, by the Right Hon. Sir JOHN SINCLAIR. As the territories under the control of France had, for many years, been inaccessible to British travellers, it seemed likely that, in the more fertile districts, several changes, and possibly improvements, both in agriculture and gardening, might have taken place, the knowledge of which it would be desirable to introduce into this country. The patriotic individual just named had recently before visited the Netherlands, with the view of investigating the state of Flemish husbandry; and the minuteness and accuracy of his researches are evinced in the work which he has since published, intitled "Hints regarding the agricultural state of the Netherlands compared with that of Great Britain." He suggested, that a similar inquiry into the state of Horticulture in the Low Countries might be proper; and his proposal was seconded by a learned and eloquent member (FRANCIS JEFFREY, Esq.), who was pleased to point out Mr THOMAS DICK-

SON and myself, the two Secretaries of the Society, as fit persons to be entrusted with the mission. We did not hesitate to undertake it; but the state of health of my excellent colleague, which had long been precarious, soon unfortunately became worse, and he died on the 23d May 1817.—The Horticultural Society lost, in him, a most enlightened, zealous and disinterested supporter. He was one of its founders: often, during his protracted illness, he attended its meetings, at the risk of great personal inconvenience and suffering; and to the very last, he cherished the hope of serving it, in the intended continental excursion. For my own part, I had to lament the loss of a valuable friend and judicious coadjutor, who, to a thorough acquaintance with the details of practical gardening, added many scientific acquirements.

At the General Meeting in June 1817, the Council of the Society signified its wish, that the projected survey should be accomplished that season, and should be extended to the gardens in the environs of Paris. Mr JOHN HAY, planner, Edinburgh, readily agreed to form one of the party; and on an application from Sir George Mackenzie to the late Duke of Buccleuch, His Grace at once gave his approbation to an arrangement by which Mr JAMES MACDONALD, chief-gardener at Dalkeith Park, should form another.

It was concerted that we should set off about the middle of July; but, owing to various circumstances,

the end of that month had arrived before we were ready to depart. On account of our avocations at home, the time which we could now dedicate to the business was limited to less than three months; and we were, from the first, perfectly aware that this was greatly too short. We were obliged, therefore, considerably to restrict the plan of our journey, and also in some degree its objects; but still the want of sufficient leisure for due examination was repeatedly felt. We visited some of the richest parts of Austrian Flanders, Brabant and Holland; and afterwards proceeded, by Enghien and Tournay, towards Paris. At the French capital we spent some time; and then returned homeward through Normandy.

One principal object which we kept in view, was to take notice of any new or uncommon varieties of fruits and culinary vegetables, which it might be desirable to introduce into Scotland; and to establish a correspondence with some of the principal amateur cultivators and professional nurserymen, through whose good offices such acquisitions, by means of cions or of seeds, might afterwards be obtained. This object, we trust, will be found to have been satisfactorily accomplished. We met with the most cordial and friendly reception from such of the distinguished foreign horticulturists as we had occasion to visit; and we take this opportunity of publicly acknowledging their kindness.

The journey was undertaken in the anticipation of the speedy establishment of an Experimental Garden under the auspices of the Society,—in which such promising articles as we should become the means of procuring, might be subjected to a fair trial. The want of such a repository has hitherto prevented the fruits of our labours from being duly reaped. But we have now to congratulate the Society on the prospect of this deficiency being supplied at no distant period; and we are confident that our horticultural friends and correspondents on the Continent will still, notwithstanding the lateness of our applications to them, amply fulfil their promises of supplying us with whatever shall seem desirable from their respective districts.

Some apology for the delay of this publication may appear necessary. In point of fact, such a work did not enter into our contemplation. Shortly after our return, two Reports from the Deputation were read, at different meetings of the Society; and it was not intended to say more on the subject till the operations of the Experimental Garden had commenced, when some practical results could be appealed to. Several highly respectable members, however, having expressed a desire to see the *Journal* of our Tour in a printed form, the Council of the Society requested us to send it to the press. The task of preparing the MS. fell upon me; and only a few sheets had been cast off, when illness compelled me to lay aside the undertaking for more than a year.

In consequence, however, of this delay, and of my having made a second trip to the Continent in 1821, I have been enabled to supply an account of some of the excellent horticultural establishments at Paris, which we were obliged to leave unvisited in 1817.

Our original notes were pretty extensive, having been regularly made out every evening; but they were necessarily expressed in a brief manner, and frequently unconnected. In transcribing them for the press, little more has been done than reducing them into some kind of order, and enlarging sufficiently to give to each day's journal the character of a connected narrative; the diary style being otherwise carefully retained. In a very few places only, have some additional remarks been thrown in; and these, I perceive, have occasioned some slight anachronisms, for which the reader's indulgence is craved. We wish it to be understood, that we claim no merit whatever, except in reporting as faithfully as possible what we saw, and as accurately as our hurried movements would permit. The literary imperfections of the work must be ascribed wholly to myself; while any useful horticultural remarks that may be found, are doubtless due to the experienced professional friends with whom I had the good fortune to travel. The occasional introduction of topics unconnected with gardening, might, it was judged, tend to interest a wider circle of readers, without infringing materially on the principal object. But, as our route lay through places which are among the

best known in Europe, little novelty, we fear, can be expected.

It may perhaps be thought, that we have announced very few improvements in the general style of gardening, or even in particular practices of culture, as existing in the foreign districts which we visited. The truth is, we were led to form the opinion that our own style of gardening in Scotland is, generally speaking, superior to what we witnessed on the Continent: it may be very true that we originally derived our horticulture from the Flemings and the Hollanders, but it seems equally certain that we have now, in many respects, surpassed them. Details of some particular practices and modes of culture not undeserving of attention, will be found in our journal; and that others, of more importance, may exist, seems highly probable: but to have gained a knowledge of these would have required a residence of considerable duration at each place, such practices being only exemplified at certain seasons of the year; and we found, that we could acquire little information by oral means in the Low Countries, the practical gardeners there speaking only Flemish and Dutch, languages in which we could not easily communicate with them.

PAT. NEILL,
Sec. Cal. Hort. Soc.

CANONMILLS, }
2d December 1822. }

GENERAL
TABLE OF CONTENTS,

SHEWING THE ROUTE FOLLOWED, AND THE
PRINCIPAL PLACES VISITED.

JOURNAL.

From Leith to London, page 1.

LONDON. Covent-Garden market, 2.—Andrew's forcing garden, 3.—Chandler and Buckingham's nurseries, 6.
—Lambeth Palace-garden, 7.—Mile-End Nurseries, 9.

London to Dover, by CANTERBURY, 11-14.

DOVER, 15. Terrace-garden at the Castle, 16.

Dover to Ostend, 18.

OSTEND, 19.—Green-market, 20.—Fort Wellington, 21.

Ostend to Bruges, 22.

BRUGES, 23.—Green-market, &c. 24.—Villa of M. Bertrand, 26-29.—Garden of Capuchin Friars, &c. 30-33.

Bruges to Ghent, 35.

GHENT, 36.—Green and fruit market, 37.—Botanical garden, 38-43.—De Cock's nurseries, 44-46.—Smedt's market-garden, 47.—Villa of Mr Meulemeester, 55-57.—Baron de Vroeylande's seat at Oeydonck, 59-64.—Flower-market, 66.—M. De Wulf's gardens, 67-69.—Hopsomere's fine villa, 70-74.—Splendid seat of Madame Vilain-Quatorze, 75-85.

Ghent to Antwerp, 90.

ANTWERP, 91.—Green-market, 93.—Elegant place of Mr Smetz the banker, 97–111.

Antwerp to Rotterdam, by Bergen-op-Zoom and Williamstadt, 114–116.

ROTTERDAM, 120.—Van Schenen's garden, 121.—Schuurmans' villa, 125–127.—Vegetable market, 128.—Boompies, &c. 133–136.

Rotterdam to the Hague, by Delft, 139–141.

THE HAGUE, 142.—The Mall, 143.—The House in the Wood, 144.—Scheveling, &c. 146–148.—The Hof, 149.

The Hague to Leyden, 150.

LEYDEN, 151.—Botanical garden, 152–161.—Green-market, 162.—University, &c. 163–165.

Leyden to Haarlem, 166.

HAARLEM, 167.—Van Eeden's bloemistries, 169.—Palace-garden, 171–174.—Kreps and Co.'s bloemistry, 175–179. Elderling's bulb-nursery, 181–186.—Voorhelm's nurseries, 187.—Schneevogt's bloemistry, 190–193.—Kreps' tree-nurseries, 200–205.

Haarlem to Amsterdam, 211.

AMSTERDAM, 212.—Botanical garden, 213–218.—Green-market, 219–223.—Fruit-market, &c. 224–227.—Public establishments, &c. 228–237.

Amsterdam to Utrecht, 240–242.

UTRECHT, 243.—Botanical gardens, 244.—The Mall, 254.—M. Seterveldt's garden in the old style, 247–250.—Ziest, 251.—Flora's Hof, 254.

Utrecht to Breda, 257–260.

- BREDA, 265.—Keperken's nurseries, 266.
- Breda to Brussels, by Antwerp, 267-270.
- BRUSSELS, 271.—Vegetable and fruit market, 273-275.—
Botanical garden, 276.—Palace of Lacken, 278-280.—
Field of battle at Waterloo, 281-292.—Duc d'Arem-
berg's town-garden, 295-297.—M. Danoot's garden,
298-300.—Professor Van Mons' Pepiniere de la Fide-
lité, &c. 301-312.
- Brussels to Enghien, 314-316.
- ENGHIEN, 317.—Duc d'Aremberg's fine seat, 318-324.—
M. Parmentier's rich gardens, 325-331.
- Enghien to TOURNAY, 332-334.
- Tournay to LILLE, 336-338.
- Lille to Paris, by Amiens, Clermont, and Lusarches,
339-343.
- PARIS, 344.—Marché des Innocens, 346-349.—Jardin des
Plantes, 350-355.—continued, 383-395.—concluded,
441-445.—ST GERMAIN-EN-LAYE, 356-368.—Tui-
leries gardens, &c. 370-374.—Marché aux Fleurs, 375-
378.—Tivoli garden, 380.—La Malmaison, 396-405.
—VERSAILLES, 406-414.—Luxembourg gardens, 415.
—Botanical nurseries of Cels, 417-420.—Vilmorin's
nursery-garden, 421-423.—his seed-warehouse, 446.—
MONTREUIL peach-gardens, 424-435.—VITRY nurse-
ries, 447.—Park of Mouceaux, 451.—M. Boursault's
villa, 452-456.—Noisette's nurseries, 457-468.—Char-
treux nurseries, 469-474.—Roule nurseries, 475-482.
- Paris to Rouen, 492-493.
- ROUEN, 494.—Botanical garden, 495.—Vallet's collection
of orange-trees, 496.
- Rouen to Dieppe, 498.

Dieppe to BRIGHTON, 499-500.

Brighton to London, 501.

LONDON. Portman Nurseries, 502.—Lee and Kennedy's, 504.—Kensington Gardens, 505.—Chiswick, 506.—Kew, 507.—Spring Grove, 508.—Windsor, 509.—Fulham, 510.—Mr Angerstein's, 511.—Grange's at Hoxton, 512.—Loddiges' at Hackney, 514.

APPENDIX.

1. Catalogue of Fruit-trees in De Cock's nursery at Ghent, 519.
2. Tract on the culture of Hyacinths, by Mr Kreps of Haarlem, 521-528.
3. List of some new Roses, raised by Mr Brown of Scone, 529.
4. Extracts from Justice's "Scot's Gardener's Director," and from Van Kampen's "Dutch Florist," 530-537.
5. On the species and varieties of Elm-trees, by Mr David Don, 538.
6. On the advantages of planting Fruit-trees on declivities, by the late Dr Walker, 540.
7. List of Pears received from Mr Van Mons, young trees of which exist in the Leith Walk and Broughton Nurseries, 541.
8. List of Fruit-trees, &c. cultivated in the Jardin des Plantes, Paris, 542.
9. Description of Pinus Laricio, taken by Mr Don, from a specimen in the Jardin des Plantes, 552.
10. Notices, by Mr Don, of rare Plants in the Jardin du Roi, 553-556.
11. Mr Hay's Journal in Hampshire, 557.

The materials of the volume being necessarily multifarious, and the same subject sometimes repeatedly adverted to, a copious alphabetical index has been subjoined.

INDEX, 559-568.

ENGRAVINGS.

- I. Sketch of an ancient Mulberry-tree at Canterbury, described p. 14.
- II. Ground-plan of the suite of Hot-houses, and eye-sketeh of part of the pleasure-grounds, at the seat of Madame Vilain-Quatorze near Ghent ; p. 80.
- III. Section of the west end of the same hot-houses ; p. 81.
- IV. Plan of an ornamental Bridge in the pleasure-grounds at Wetteren ; p. 82.
- V. Sketch of the Palm-tree of Clusius, still growing in Botanical Garden at Leyden ; p. 156.
- VI. Plan of the large Hot-houses at La Malmaison ; p. 399.
- VII. Section of the same ; p. 400.

JOURNAL
OF A
HORTICULTURAL TOUR,

&c. &c.

Aug. 1. 1817.—**W**E sailed from Leith on the afternoon of the 1st of August, in the *Czar*, one of those elegant and commodious vessels which ply between that port and London. We made a prosperous voyage, having entered the Thames in little more than four days.

LONDON.

At the metropolis we spent two or three days, perhaps not unprofitably; for, though all of us had previously resided for some time there, we now examined with increased interest the horticultural productions with which its market is supplied, in order that we might compare them, as to quantity and quality, with those we should witness in the foreign cities we were about to visit.

Covent-Garden Market.

The place of our morning's resort, therefore, was the vast green and fruit market of Covent Garden, where are to be found concentrated all the best vegetable productions of the rich environs of London. Any remarks on the qualities of these, however, it may be better to delay till we again reach the capital on our way home. It may here, only, be noticed, that in a fruit-shop, we observed a large and fine specimen of the *New Providence Pine-apple*, a variety introduced into England of late years, and which is still a rarity in Scotland. The fruit is short and broad below; the pips are few in number, but large and full swelled: when ripe, the fruit is of a light yellow colour. It acquires a large size; the specimen above mentioned, weighed, when fresh, not less than 5 lb.; and we were assured that specimens sometimes occur of nearly double that weight. Excellent plants of this variety may be had at the Portman Nurseries, New Road, belonging to Mr Jenkins. The leaves are long, and of a pale or whitish green.

Andrews' Forcing-garden.

Aug. 6.—Before we left Edinburgh, our attention had been called by the Earl of Wemyss*, to the forcing-garden of Mr Andrews near Vauxhall, where he raises pine-apples and grapes to a great extent for the London market. The first part of this day, therefore, was spent in visiting this establishment. The number of hot-houses, vine-ries and hot-bed frames here crowded together in a small space of ground, surprised us, and gave us a lively idea of the riches and luxury of the metropolis.

* Then President of the Caledonian Horticultural Society.

The stock of *pine-apples* is very extensive, consisting of several hundred fruiting plants, and several hundred succession plants. Here we found the New Providence pine-apple before mentioned, cultivated in perfection; together with great quantities of the well-known and excellent variety called the Queen. In propagating ananas, Mr Andrews uses suckers only: These are allowed to remain long on the parent plants, so that when they come to be detached, they are of a larger size and more forward growth than is usual. But he has also other reasons for preferring suckers to crowns: there is always much difficulty and trouble in getting the crowns returned after having been presented at table, and there is a great risk of different kinds being mixed, through the carelessness of servants. His stock is perfectly clear of the coccus*; and he keeps it so, by thus avoiding all intermixture, and consequently the hazard of the introduction of infected plants. The suckers are planted in pits in September, and placed in beds of tan in hot-houses furnished with furnaces and flues; here they pass the winter, and remain till late in the spring. They are then transferred to large hot-beds, or pits, which have tanners' bark in the centre, and are furnished with exterior linings of horse-dung. In these hot-beds they are found to grow remarkably fast during the summer season. In autumn they are again returned to the hot-houses, to pass the winter; and in the course of the following season, they are forced into fruit, partly in the hot-houses, and partly in the hot-bed frames. Some of those potted in September last (1816,) were already so far advanced, that it was expected they would afford ripe fruit in November next, or about fourteen months after planting.

* *C. hesperidum*; often called Pine-bug, and sometimes Turtle-insect.

For increasing and keeping steady the temperature in several of his hot-houses, Mr Andrews has of late employed *steam*, in aid of the ordinary flues conveying smoke and heated air. The steam is carried through the house by means of metal pipes, which are laid along the top of the brick flues. The pipes are of copper, on account of its expanding less than lead. They are of a square form, and are set on edge, so that any condensed vapour trickling to the bottom may occupy little room, or present only a small surface. As in the common steam-engine, the boiler is made to regulate itself by a simple contrivance: it is furnished with a float, which descending in proportion as the water is dissipated in steam, in due time raises a valve and admits a new supply of water. The superfluous condensed vapour also returns to the boiler, there being no other provision for disposing of it. It is scarcely necessary to add, that, by merely opening a valve, the house can at pleasure be *steamed*, i. e. filled with steam, than which nothing can be more conducive to the health and vigour of plants confined in a hot-house*. By this plan there is a considerable saving in the article of coals, which, in districts where this kind of fuel is sea-borne and costly, becomes of importance. We were assured, that seven bushels of coal go as far in keeping up the steam-heat, as ten bushels do in maintaining an equal temperature the other way. When the aid of steam is resorted to, the temperature is found to be more easily regulated, continuing equable for a very considerable length of time. Mr Andrews *junior* mentioned, that the furnace being duly charged, and the boiler prepared, he could with confidence leave the hot-house for

* Mr Fraser, founder in Long Acre, manufactures the kettle, pipes, &c. which are most approved by the gardeners in the vicinity of London; but we have brass-founders in Edinburgh who could easily make the whole.

eight or even ten hours together, being satisfied that the temperature would continue to be maintained for that length of time.

The 'only kinds of *grape-vines* cultivated by Mr Andrews, are the Black, *Hamburgh* and the White *Sweet-water*. The former is the variety here preferred: the vine is a sure bearer; and the bunches of grapes being generally of considerable size, while the individual berries are large and showy, they are excellently suited to the market. Two of the vineries consist of glass on every side, with what are called *span-roofs*. In these the vines are trained on both the side-walls, and along the slopes of the roof. The flues are situated in the middle of the houses. Very little fire-heat is given; larger and surer crops being thus obtained, though at a later period of the season.

In one large forcing vinery of the ordinary construction, the vines are close pruned, and cover only the front and back walls of the house. The centre part or floor is filled with *strawberry plants*, in pots; these produce their fruit in April, when a ready market is found, at high prices. The kind preferred for forcing is the *Virginia or scarlet* (*Fragaria Virginiana*), the same that is most common in the *Edinburgh* market. We saw about 7000 pots containing plants in a state of preparation for forcing: the plants are forced only the second year after potting, so that they may be in full vigour when they enter the hot-house. Those plants which have been forced are not again employed, but are cast out as useless. When the forcing season is over, the front vine stems are led to the outside of the house, and kept in the open air during summer, in order to ripen the wood, and render it more firm.

It was with some surprise, and not without regret, that we remarked, that in a spot of ground where so much capital is laid out, scarcely any attention seemed to be paid

to neatness. By some very slight contrivances, and a moderate degree of care, this error might be remedied; the paths might be rendered dry and comfortable,—while we had to wade from hot-house to hot-house, though it was now the finest season of the year.

Exhibition of Fruit-trees.

On the same day, we visited an inclosure on the Portsmouth Road, not far from Vauxhall, which a large painted board announced as an “Exhibition of above five thousand hardy fruit-trees in a bearing state.” Our expectations concerning this exhibition had been considerably raised, and we must confess they were proportionally disappointed. Many of the trees were infected with the apple aphid (*Aphis lanigera*), and were neither in a healthy nor a bearing state. The want of fruit might no doubt in some degree be owing to the nature of the past and present seasons; but the general aspect of the whole establishment was nowise calculated to give satisfaction.

Camellias and Peonies.

We immediately afterwards viewed the nurseries of Messrs Chandler and Buckingham, also on the Portsmouth Road. The collection of the different varieties of *Camellia Japonica* is here very ample. The following were pointed out to us: Single red and double red; double white; double striped; Middlemist’s camellia, or double rose-coloured; double-red waratah or anemone-flowered; double Kew blush; and the double buff-coloured. The double-white waratah or pompone, is another, but very rare variety. The number of large plants of *Camellia*, from three to five feet in height, was very great; and the quantity of young plants was altogether surprising. There is here likewise a very full collection of the sea

veral species and varieties of the genus *Pæonia*; and of most of them many fine specimens for sale. The list put into our hands contained, *P. corallina*; *paradoxa fimbriata*; *peregrina compacta*, or *byzantina*; *arietina*?; *humilis*; *albiflora*, both with single and with double flowers, the latter one of the finest varieties; *daurica*; *tenuifolia*; *anomala* or genuine *laciniata*; *albiflora tatarica*, or *sibirica*; *officinalis* with double red flowers, one of the oldest of our showy garden-flowers; *officinalis* with double flesh-coloured flowers; and the same with double white, or rather very pale blush-coloured flowers. We regretted that the season for the flowers of the camellias and peonies was past, much attention being here paid to the cultivation of both genera. A new and showy species of *Lathyrus* was now in flower in the open border: it had been raised, about three years ago, from seed received from the shores of the Mediterranean, and seemed to be a perennial plant*.

Lambeth Palace Garden.

Aug. 7.—Early this morning we went to the garden at Lambeth Palace, in order chiefly to see two ancient fig-trees, said to have been planted by Cardinal Pole, about 1558, or nearly 260 years ago. We found that they had been greatly injured by the severe winter of 1813–14, and that the principal stems had in consequence been cut over near to the ground. The gardener informed us, that the stems, where cut, were as thick as one's thigh, and indeed the lower part of the original trunk is still to be seen, and confirms this statement. On one of the trees a large old branch still remains, and extends to a considerable distance along the wall. The whole breadth of this tree is

* It has since been figured and described in the *Botanical Magazine*, (vol. xlv. pl. 1938. edited by Dr Sims), under the title of *L. grandiflorus*.

about thirty feet. The branches had risen forty feet high, having been trained against the Palace wall, which is marked with nails and shreds to that height. The tree, therefore, had covered a space of 900 square feet; and it bids fair soon to equal its former self. The fruit is of the kind called the White-fig; but there is none upon the tree this season.

It may be remarked, that fruit seems to have failed very generally in Britain this year. Lambeth Palace garden, we were told, usually produces abundant crops of very fine pears, apples, plums, and peaches; but at this time scarcely a specimen of any of those fruits was here to be seen. In the garden at Dalkeith-House near Edinburgh, the apple-trees are generally exuberant bearers; but Mr Macdonald informed us, that this season they had proved otherwise; that the spring blossom had fallen off without *setting*; that successive flower-buds had expanded during the summer; and that several trees were in flower when he left home on the 1st of August. It seems likely that this is an effect of the wet and cold summer and autumn of the past year; the wood had not ripened, and the regular flower-buds had not been sufficiently matured before winter. Several seasons may elapse before the trees recover from the effects of the irregularity thus induced.

On the lawn in front of the Palace are some fine trees, of kinds which are not usual in Britain, and which in Scotland we see commonly in the form only of shrubs. The Carolina Sumach-tree (*Rhus elegans*), the Scarlet Oak (*Quercus coccinea*), the Three-thorned Acacia (*Gleditsia triacanthos*), may be mentioned; and likewise two excellent specimens of *Catalpa syringifolia*, each about twenty feet high, which, in favourable seasons, as the gardener informed us, seldom fail to produce large panicles of flowers.

A very lofty American Plane-tree (*Platanus occidentalis*) attracted our particular notice: its shape is highly symmetrical; the lower branches extend very wide, not less than 48 feet in diameter, or 144 feet in circumference; they project very considerably beyond those immediately above, and they literally sweep the grass; while the upper mass of branches and foliage is bell-shaped, and rises to the height of about 80 feet. At three feet from the ground the trunk measured nearly 8 feet in circumference. Some of the first-mentioned trees are of considerable age: this plane-tree, however, is said to be little more than twenty years old, although we should, from its appearance, have guessed it to have been at least double that age. It is in perfect vigour, and seems to have completely escaped the effects of the winter 1813-14, already alluded to, which proved fatal to many of the finest specimens of the occidental plane both in England and Scotland. We admired the taste displayed in preserving an ancient walnut-tree (*Juglans regia*), although one-half of it is dead: for, as the bare spray of the walnut-tree speedily blackens with decay, a good contrast is formed with the light-green foliage of the living part; and the whole seemed to us to accord well with the venerable antiquity of the archiepiscopal palace.

Mile-End Nurseries.

We afterwards paid a visit to the long established nurseries of Mr Archibald Thomson at Mile-End, where Mr Hay had learned some parts of the gardener's business five and thirty years ago. This place is particularly remarkable for possessing a very fine Ginkgo or Maidenhair-tree (*Salisburia adiantifolia*): it is now near fifty years old, and more than thirty feet high; it is a handsome standard tree, and probably the finest specimen of the kind in Bri-

tain. Here, too, some of the rarer American trees were first cultivated, and some of the original specimens still remain. Mr Hay measured the trunk of a large Catalpa tree, which was 5 feet 9 inches in circumference, at three feet from the ground; and the height of the tree was, by estimation, about 25 feet. Several Magnolias were worthy of notice; in particular, large plants of *M. glauca*. It may be mentioned, that Mr Thomson has procured a hybrid seedling magnolia, between this species and *M. tripetala*: hitherto, he alone possesses this novelty, and, according to the custom of the trade, he will not dispose of any of the plants till he acquire a store of it by inarching on common stocks. The Aniseed-tree (*Illycium Floridanum*) had here stood in the open air for several winters; but it requires a sheltered situation, and prefers a shady border. The Aster argophyllus, or musk-plant of New Holland, had passed the last winter without any kind of shelter. A very large specimen of the single-flowered red Camellia is planted in the open border, and trained against a wall, in a confined situation resembling a court. It fills a space about 12 feet high, and 16 feet wide. During winter it is covered with a glass frame. This plant was originally at Wanstead-House Garden, and was brought hither about twenty years ago. Thousands of cuttings are yearly taken from it, in order to form stocks on which to work the double-flowered varieties.

London to Dover.

Aug. 8.—Having resolved to proceed to Dover, and embark either for Calais or Ostend, as circumstances might direct, we left London on the 8th of August on our way to Canterbury.



Kent.

In the richer parts of the county of Kent, proceeding by Dartford and Rochester, we found wheat-harvest begun. Here the scythe is used for cutting down the corn crops; and in level fields, mowing seems much more convenient and expeditious than our Scottish mode of reaping with the hook. Accustomed as all of us had been to see Small's plough, with two horses managed by one man, employed in tilling the heaviest clay soil, we were not a little surprised to observe a team of four strong horses, with a ploughman, and the appendage of a driver, engaged in merely turning over light land in a state of fallow. We had scarcely finished our remarks on this curious exhibition, when we noticed three horses yoked to a drill-machine (apparently sowing turnips after pease), where certainly one horse would have been amply sufficient. We are certain that there was nothing in the soil,—a light loam, incumbent on gravel and chalk,—or in the inequalities of the surface, requiring such a power of horses, and are persuaded that this expensive and wasteful practice is to be ascribed only to inveterate habit.

The hedges are in general of hawthorn (*Mespilus oxyacantha*). They seem in many places much neglected, being allowed almost to run wild, and often to become choked with climbing plants, such as traveller's-joy (*Clematis vitalba*), bryony (*Bryonia dioica*), and convulvulus (*C. sepium*). If in this favoured district, such hedges be found sufficiently effective as fences, the traveller has evidently an interest in preferring them: they certainly improve the landscape of the country, and are more pleasing to the eye than delights in the picturesque.

Many of the plants which now appeared most common on the road sides, are of rare occurrence in Scotland. In

some places, the chalky banks seemed to acquire a blue hue from the profusion of the flowers of succory (*Cichorium intybus* *). In other places the cotton-thistle (*Onopordon acanthium*) held almost exclusive possession; and for many miles, greater knapweed (*Centaurea Scabiosa*), celandine (*Chelidonium majus*), and wild basil (*Clinopodium vulgare*), formed the common weeds of the road-side. The grand and massy ruins of Rochester Castle presented us with a botanical rarity, during a very hurried visit which we paid to it; in several places, the mouldering walls are covered with single red carnations (*Dianthus Caryophyllus*), which were now in flower. We should have been apt to consider these as accidental wanderers from some neighbouring garden; but Sir James Edward Smith, in his *Flora Britannica*, has not scrupled to describe the plant as indigenous to England, and to mention this castle as a principal *habitat*.

In the course of the day we passed numerous cherry orchards; sometimes with interspersed rows of filbert-trees trained like bushes. The common kind of cherries called Kentish, as well as the red and black hearts, had almost all been gathered; but the morellas still remained on the trees. Apple and pear orchards were also frequent. Some few of the pear-trees had good crops; but the apple-trees were in general nearly destitute of fruit. Hop plantations likewise began to appear; and they increased in number as we approached Canterbury. The bunches of flowers seemed thinly scattered; but they were yet small, and will probably make a much better appearance three weeks hence.

* Succory has not found a place in Lightfoot's *Flora Scotica*; yet it is as well entitled to it as Celandine, which is admitted. In like manner, Bryony is enrolled, and Traveller's-joy is excluded; while the claim of both to be ranked as Scottish plants is on a par.



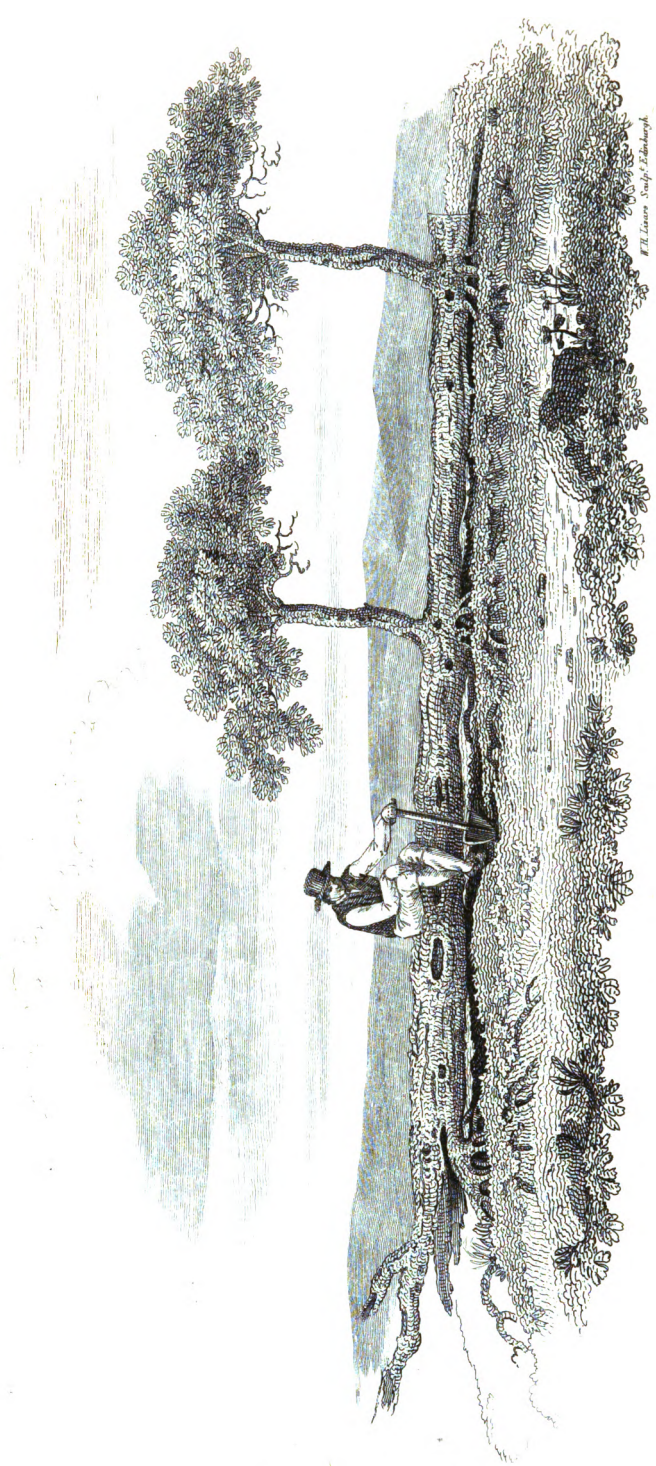

ANCIENT MULBERRY TREE AT CANTERBURY.

It may, perhaps, be proper to apologize for introducing such remarks as these, on a county so well known as that of Kent, and which has been illustrated by Hasted, in a work extending to twelve volumes in octavo. But we give only remarks actually made on the spot, and at the times mentioned ; and during a rapid journey, these could neither be very numerous nor important.

CANTERBURY.

We spent the afternoon at the seat of the ancient Metropolitan See of Canterbury, greatly pleased with the cleanliness of the streets, with the beauty of the terrace-walks on the ramparts, and with the fine avenues of lime-trees below ; but not a little disappointed, to find workmen engaged in razing to the ground a *keep* or strong-hold of Norman architecture, with walls ten feet thick : this, we think, might have been spared, both as an ornament, and as indicating the antiquity of the place. After having surveyed the famed Cathedral, and made a pilgrimage to the shrine of Becket, we visited the ruins of the Abbey of St Augustine, said to have been the earliest Christian establishment in England. In the neighbourhood of this abbey, we understood, were still to be seen some remains of Monkish gardens. We accordingly found a mulberry-tree, two vines, and three or four walnut-trees, all of them possessing the marks of great age.

The *mulberry-tree* is of the common black species (*Morus nigra*). The tree has a venerable aspect. It had once been both lofty and spreading ; but had been blown down, and has lain on its side for the last century or more. One old man in Canterbury remembers it in its present recumbent posture for above seventy years past, and declares that he knows no change on it. By permission of the lessee of the

garden, we particularly examined it; and as it appeared to us a vegetable curiosity, we may perhaps be excused for some minuteness of description, and for illustrating our description by a rough sketch *. The remains of the original trunk, now lying horizontally on the ground, measure in length $21\frac{1}{2}$ feet; and in circumference, at four feet from the root, 5 feet 8 inches. Two large branches have risen perpendicularly, and now perform the office of stem, forming a new tree with a double head. The first of these subsidiary trunks, which springs off at the distance of thirteen feet from the original root, measures in height 6 feet before it forks; and it is 3 feet in circumference. The other new stem comes off nearly at the upper extremity of the old trunk, and rises $7\frac{1}{2}$ feet before dividing; like the former, it is about 3 feet in circumference. Both of these form handsome heads, and, taken together, cover a space of 30 feet by 24. On examination we perceived that a certain continuous portion of the bark was fresh all the way from the original root; and, by removing a little of the earth, we likewise ascertained, that many new roots, though of small size, had been sent off from the base of the two branches which had formed themselves into stems and heads. The fruit of this aged tree is excellent; indeed it is commonly said, that the fruit of the oldest mulberry-trees is the best. In 1815, the berries, sold at 2s. a pottle, yielded no less than six guineas. We were told that they are commonly bought up for desserts, by the "gentlemen of the Cathedral," who, like their predecessors, are probably no bad judges of such matters.

The two vines are of the variety called the Small black cluster grape; the berries being small, and the bunches close or compact, and not large. The stems, when examin-

* See Plate I.

ed at the surface of the ground or near the roots, evince the great age of the plants; but nothing precise is known of their history. Both are trained to an antique wall, which is about 15 feet high, and built partly of Kentish rag-stone, and partly of the nodules of flint which occur in the beds of chalk in this county. One of the plants covers at present about 36 feet of this wall; and both, taken together, occupy nearly 60 feet.

The walnut-trees are also evidently of great antiquity; and they are fast going to decay. They had stood in a small orchard exterior to the walled garden, and this spot has now unluckily become the site of a farm-yard. The roots of the trees are either surrounded with pig-sties and dunghills, or absolutely immersed in offensive mires.

DOVER.

Aug. 9.—Early this morning we left Canterbury for Dover. The country now became more varied with hill and dale. In many places it was clothed with forest trees; ash, maple (*Acer campestre*), chesnut, English elm, and different species of willow. Thousands of the finest young stems appear to be annually sacrificed for the making of hop-poles: we saw great collections which had been felled for this purpose. The grain crops were not so forward as in the range of our yesterday's ride.

On reaching Dover, we learned that a Post-office packet was to sail in the evening for Ostend; and we determined to cross the Channel in that direction. We employed the day in viewing the celebrated cliffs and castle of this place, and such gardens as were near at hand.

Terrace-Garden at Dover Castle.

One of the most curious gardens is situated immediately below the cliffs on which the Castle is built, and close

by the sea. It is attached to a small house, to which the Earl of Liverpool, as Governor of the Castle, has at present a right. The garden consists merely of four successive terraces, cut in the shelving chalk and flint rock, and communicating by flights of steps. Great pains appear to have been bestowed, in former years, in cultivating this romantic spot; but we are sorry to say that at present it is verging to a ruinous state. The perpendicular face of the chalk-rock is built up with flints in the form of a wall, ten feet high. To this are trained some vines, which are healthy and vigorous, the extreme points of the shoots being still in a growing state, although so late in the season. A White Muscadine shewed some bunches, and we understood that the grapes generally ripen here; we were told that they came to maturity even in the very unfavourable season of last year (1816). Two plants of the Black Cluster vine cover about 70 feet of wall, and also produce some fruit. Were the plants judiciously pruned, they would doubtless be much more productive; but they are grossly mismanaged. The local situation of these vines could not fail to remind us of what we have often read, concerning the rocky banks of the Rheingau, and recesses in cliffs in Italy, being planted with vines which yield the finest grapes. But although the soil is very scanty, it seemed evident that a considerable degree of moisture must be constantly supplied, without stagnating; and to this regular supply, the invariable success of the crops is probably to be ascribed. There are also in the garden two or three apple-trees and cherry-trees: a few morellas had been produced this season, but no apples. The soil and situation appeared more congenial to some small standard fig-trees, of the variety called Blue-fig, which had fruit on them, already of a large size, and which, we were told, ripen in October. On the shallow and light chalky soil, the roots

can never be chilled, and they must always be comfortably dry: the proximity of the sea must temper the severity of the frost during winter; they are, besides, well sheltered by the rock; and the reflected heat must be powerful during summer. We may here remark, that in a much better managed garden, in a low situation in the town of Dover, figs never ripen. The fig-trees in this last garden grow to a large size as standards, and abundance of young fruit appears in the early part of summer; but it uniformly drops off in the immature state. The roots of the trees have probably penetrated to a cold and retentive stratum, kept wet by the water passing from the higher grounds*. We measured the largest of these trees, and found it to be no less than 3 feet 3 inches in circumference, about half a foot from the surface of the earth. Here it branches off into six stems, several of which are about 16 feet high. The tree covers a space more than twenty feet in diameter. The ground beneath was strewed with the young fruit which had dropped off, and which appeared to us to be the blue fig.

Botanical Walk.

Along the base of the cliffs below the Castle, the native Cabbage, *Brassica oleracea*, grows in vast profusion. This is a plant interesting not only to the botanist, but to the horticulturist, as the parent of the long list of cultivated cabbages, kale, broccoli and cauliflower. Through-

* The pernicious effects of water on the roots of fig-trees, have been particularly mentioned by Mr James Smith, gardener at Hopetoun House, in his excellent paper on the Cultivation of Figs, printed in the "Memoirs of the Caledonian Horticultural Society," vol. ii. p. 69. *et seq.* His conclusion, however, that fig-trees prefer a rich friable deep loam to a light calcareous soil, does not accord with our observations at Dover.

out the winter season, we were told, many of the common people come from Dover, and gather this primary cabbage for use as a pot-herb. Another excellent culinary plant, Parsley, *Apium petroselinum*, is either a native denizen of these cliffs, or completely naturalized there: And still other two plants occur, which have occasionally been used in the kitchen,—*Alexanders*, *Smyrnum olusatrum*, and Sea-beet, *Beta maritima*. The first of these was in former times cultivated in gardens, but has for many years fallen into disuse: the flavour is strong; but if the plant be only slightly bruised, it communicates to the fingers a smell not unlike that of strawberries. We did not observe rock-samphire (*Crithmum maritimum*) on the cliffs near the Castle, nor even at the precipice which has acquired the name of Shakespeare's Cliff*; but about half a mile to the south-west, it was pretty common, generally however in inaccessible places. The walk by the beach at the foot of the cliffs, on both sides of the town, offers a treat to a botanist from the north; some of the herbaceous plants which are here of most frequent occurrence, being rarities in Scotland. One of the most beautiful of these is the matted thrift, *Statice reticulata*, which in some places covers the shelving banks.

On the evening of the 9th we sailed, in the Lord Duncan packet, Captain Pascoe, for the Continent. It was too late to enable us fully to enjoy, from the sea, the beautiful view of Dover and its cliffs; the whole scene was soon wrapped in obscurity. Enjoying a favourable breeze through the night, we found the towers of Dunkirk and Nieuport within sight in the morning.

* Half way down,
Hangs one that gathers samphire; dreadful trade, &c.

Lear.

OSTEND.

Aug. 10.—We made for Ostend, and entered the harbour early in the forenoon. The piers are wholly formed of huge piles and cross-beams of timber. The light-house is a lofty narrow tower; it is evidently recent; we concluded that it must be a work of Napoleon, and our conjecture proved right. On landing, we went directly to the Custom-house; and our portmanteaus having been slightly examined, we proceeded to the Rose Inn, kept by Nicholson an Englishman. It was Sunday; but it did not resemble the Sabbath-day of Scotland. Many shops were open; and soon after mid-day, the sounds of fiddling, singing and dancing assailed our ears. As we advanced towards the Church, a Madonna, attired in a red silk robe and a white veil, with a burning lamp placed before her, forcibly reminded us that we had now entered a Roman Catholic country. Within the church, about a hundred children were assembled, the boys ranged on one side, the girls on the other; while a priest walked up and down the centre, catechizing his youthful audience in Flemish, and exhorting them with great apparent earnestness. We had been accustomed in the old city of Edinburgh to see the gables of houses presented to the street, which is the common mode here; but almost every thing else wore a foreign aspect. The sign-boards bore Flemish and French inscriptions, excepting that here and there, since the peace, some awkward attempts had been made at English, particularly by the keepers of low taverns likely to be frequented by our sailors*. It was to be expected that a shore separated from England merely by the Channel, should afford the same

* Over one door was painted, "Spiritual liquors." Over another, "All sortes of drinking sold here." And over a third, "Here sold all mens drink."

plants ; and *Chenopodium maritimum*, *Aster tripolium*, and *Salicornia herbacea*, accordingly presented themselves. But some of those which are common at Ostend are rare in England ; such as the loose panic grass, *Panicum grus galli*, and upright spear-leaved orache, *Atriplex erecta* : And as we strolled along the ramparts and by the sides of the ditches of this fortified town, we met with at least one plant entirely unknown to the British Flora, *Lepidium Iberis* or bushy pepperwort *. We noticed patches of houseleek or *fouet* (*Sempervivum tectorum*) planted on the roofs of the houses of the lower orders, as with us.

Around Ostend there are no gardens nor villas ; indeed, for several miles the country seems almost waste. This, however, must generally be the case near fortified places, where trees or garden-walls are always levelled on the first alarm of a leaguer. We formed no high opinion of the industry of the humbler class of the inhabitants, from this circumstance, that close by their houses were numerous spots of ground lying totally waste and neglected, which, with a very little trouble, might afford excellent crops of kitchen vegetables. Only in one or two places did we observe that they had planted some small beds of potatoes.

Green Market.

Aug. 11.—In the morning we visited the green market (marché aux herbes.) There was nothing remarkably fine ; nor, in a seaport town, was any thing extraordinary to be expected. Many peasants, chiefly women, had come in from the country, with asses bearing a pair of panniers, loaded with kitchen-stuffs and small quantities of fruit.

* This plant does not appear to be common in the Netherlands ; for it is not enumerated in Roucel's Flora of that country.

The endive (*Cichorium Endivia* *) was generally good, being long in the leaf, and pretty well blanched. Green purslane (*Portulaca sativa*) was common on the stalls. Carrots (*Daucus carota* var.) of the horn variety, were excellent, being large, and quite clean, or free from disease or the attacks of grubs. The excellence of the carrots probably depends on the nature of the soil, which is sharp and sandy, and of considerable depth. Common centaury (*Chironia centaurium*) must be very abundant on the downs; for we remarked that quantities of it, now in full flower, had been used in place of grass or hay, for packing various articles brought to market.

Fort Wellington.

In the famous siege of Ostend in the beginning of the 17th century, no fewer than 100,000 of the best troops of Spain met their death. Strong, however, as the place must formerly have been, two new bomb-proof forts have of late years been added. By the kindness of M. Delamotte, the Mayor of the town, we procured admission to one of these, now called Fort Wellington. At a short distance, this fort appears buried among the sandhills, but it completely commands the entrance to the harbour. The sea, we were told, frequently inundates the low grounds, and

* The reader will observe, that when any culinary plant, &c. is mentioned for the first time, the Linnean or scientific name is added. Whoever has been in the practice of looking into French, German, or Italian horticultural works, where this is not attended to, will be convinced of the propriety of adopting such a rule. Our own vernacular names are frequently dubious in their application; and if a foreigner were to consult Johnson's Dictionary, he certainly would have no chance of being extricated from his difficulties, the Doctor seldom giving any other kind of explanation than this: "Endive, a plant,"—"Purslane, a plant." In the case of foreign plants, the nomenclature of Willdenow's edition of the *Species Plantarum* is generally adopted; for plants indigenous to Britain, that of Sir J. E. Smith's *Flora* is preferred.

throws down parts of the old out-works ; but the glacis of Fort Wellington next to the sea, is strongly faced with large masses of grey limestone from Tournay, which will probably long withstand the action of that element. Among the sandhills we found cut-leaved elder (*Sambucus nigra* var. γ), and sea-buckthorn (*Hippophaë rhamnoides*). *Hordeum maritimum* was not uncommon by the sides of the devious path through the downs ; and *Anchusa officinalis* appeared in one or two spots. In some places, near the Fort, small wisps of wheat-straw had been pushed deep into the sand, in order to arrest the blowing. In other places, *Arundo arenaria* and *Elymus arenarius*, had been planted, but in a slovenly and injudicious manner. The sandflood still proves very troublesome ; and Fort Wellington was in many parts almost blocked up with drifted sand at this time.

Numbers of peasant women who had been at market with country produce, were now plodding their weary way homeward, along the firm beach from which the sea had retreated, seated on their asses, between the two empty panniers. They formed an extensive irregular cavalcade more than a mile in length, and produced altogether quite a novel and foreign scene.

From Ostend to Bruges.

In the afternoon, we set off for Bruges, by a commodious barge, dragged by two horses, along a noble canal. This canal is from 80 to 100 feet wide: it is upon one level, or has only a sea-lock at a place called Sass, from whence it goes nearly in a straight line to Bruges, which is perhaps about 14 miles distant. It is kept in excellent repair, the banks being supported with stake and rice work of willow and alder. The country, as far as the eye could embrace it, was quite level. The crops were rye, wheat, barley, buckwheat, flax, beans

and potatoes. Buckwheat, or *sarassin*, (*Polygonum Fagopyrum*), it may be observed, is here extensively cultivated; and on inquiry, we learned, that it is valued, not merely for feeding poultry with the grain as with us, but for the sake of the flour, which is very white, and is often mixed with the flour of wheat and rye for the use of the people. Willow pollards are common, and coppices of alder. Near to Bruges, elms (*Ulmus campestris* and *suberosa*) planted by the sides of the canal, have attained considerable size. We saw, in passing, only one country seat, consisting of a neat house, with considerable ornamental grounds. We found large sloops and several brigs lying at the quay of Bruges, which did not fail to remind us of the former commercial importance of the place. We took up our abode at the hotel called *Fleur de Bled*, kept by M. Sobrie, and which proved a very good inn; it being true, as stated in the landlord's engraved English card, that the guests are "waited with the greatest nimbleness and zeal." To this hotel did Louis XVIII. retire, when obliged to abandon Lisle, in the end of March 1815.

BRUGES.

Aug. 12.—Early in the morning, we took a walk through this ancient, large, but now comparatively deserted city. From the total absence of bustle in the streets, we could scarcely bring ourselves to believe that the city which we now perambulated was once the emporium of the North of Europe, and ranked above London.

Green-Market.

We first examined the culinary vegetables brought in from the country in hampers for sale. There was little deserving of notice, unless perhaps a kind of red kidney potato, which appeared to be an *early* variety, having already (12th August) the spotted appearance of maturity,

and the epidermis easily separating on being rubbed. The *late* red kidney potato, it will be recollected, is one of the oldest sorts, and is not much liked in Britain; while an *early* red potato of the kidney shape is, we believe, unknown at home. Purslane, both of the green and the golden variety, is common; and summer savory (*Satureia hortensis*) was plentiful on the stalls. Red Dutch cabbage was common; but, what seemed strange, the white cabbage was not to be seen.

Rising from amidst the confined gardens attached to the hotels or principal dwelling-houses, we frequently remarked large plane-trees, both oriental and occidental, in a perfectly healthy state; and likewise walnut-trees, often 50 feet high.

Market Garden.

Having readily obtained permission, we entered a *sale garden*, containing many fruit-trees, and numerous beds of kitchen vegetables. Apple-trees had but a light crop; pear-trees were loaded. Of these fruits, we saw no varieties peculiarly good or promising. The trees have been grafted on very tall stocks, not less than seven feet high. The soil is a peaty loam, mixed with sharp white sand; and this sort of soil seems to be general in this part of the Netherlands. In this garden, we first saw the Dutch white runner (*Phaseolus vulgaris*) in perfection: it grows as luxuriantly as hops do in Kent, and it is staked in the same way, three or four stakes being crossed, and tied together near the top. The seeds had been sown in the spring, and the plants were now yielding unripe pods, or *haricots verts*. Succession crops appeared in other parts of the garden; some now in flower, and others only a little above the ground. The scarlet runner (*Phaseolus multiflorus*) is sometimes, though not very commonly, used in place of the white: both the pods and the beans are good for kit-

chen use, and the scarlet flower makes an ornamental variety. Scorzonera (*Scorzonera Hispanica*) is much cultivated. Brussels sprouts * form a common crop; and a few savoys are planted. Leeks (*Allium porrum*) are planted with a spade or dibble which at one thrust makes holes for receiving two plants.

Here we observed small beds of the different culinary plants left for seed; such as carrot, white beet, onion, endive, and lettuce. Every person possessed of a garden, we find, saves his own seeds; and the business of a seedsman is in this country scarcely known, or at least he deals chiefly in agricultural seeds. Different kinds of seedling lettuces are allowed to grow intermixed, and of course the varieties cannot continue genuine or pure for any considerable length of time.

Paintings, &c.

After breakfasting for the first time on *café au lait*, we visited the English Convent, of which Madame More is Abbess,—the Academy of Painting,—and the Church of Nôtre Dame. In all of these places are some paintings by Rubens, Van Oost, and other masters; a few of the best of which had been removed by Buonaparte, and were returned from Paris in August 1815, in consequence of the “great moral lesson” taught by the Duke of Wellington.

Villa of M. Bertrand.

We next bent our steps to the country seat of M. Bertrand, a merchant of Bruges, who, we were told, pos-

* Brussels sprouts and open kale, with savoys and cabbages, cauliflower, and broccoli, are arranged by botanists as varieties of the *Brassica oleracea*, already mentioned as a native of Dover cliffs. Of several of these, there are many *sub-varieties*, distinguished by gardeners and seedsmen.

sessed the best garden in this quarter. We found the grounds extensive and well varied, considering the monotonous flatness of the country. They are laid out in the old Flemish style, with regular serpentine walks, berceaus of lime-trees having openings like windows, and with long straight walks, terminating in studied vista views. Where the straight walks cross each other at right angles, the centre of the point of intersection is shaped into an oblong parterre, resembling a basket of flowers, and containing showy geraniums in pots, and gaudy flowers of a more hardy kind planted in the earth.

Some things are in very bad taste. At every resting-place, some kind of conceit is provided for surprising the visitant: if he sit down, it is ten to one but the seat is so contrived as to sink under him; if he enter the grotto, or approach the summerhouse, water is squirted from concealed or disguised fountains, and he does not find it easy to escape a wetting. The dial is provided with several gnomons, calculated to shew the corresponding hour at the chief capital cities of Europe; and also with a lens, so placed, that, during sunshine, the priming of a small cannon falls under its focus just as the sun reaches the meridian, when of course the cannon is discharged.

The principal ornament of the place consists in a piece of water, over which a bridge is thrown. At one end of the bridge is an artificial cave, fitted up like a lion's den, the head of a lion cut in stone peeping from the entrance. Above the cave is a pagoda, which forms a summerhouse three storeys high. At the top is a cistern, which is filled by means of a force-pump, and which supplies the mischievous fountains already mentioned.

The little lawns near the mansion-house are decorated with many small plants of the double pomegranate, sweet bay,

laurustinus, and double myrtle, planted in large ornamented flower-pots and in tubs. These plants are all trained with a stem three or four feet high, and with round bushy heads, after the manner of pollard willows in English meadows. The appearance produced by a collection of such plants is inconceivably stiff, to an eye accustomed to a more natural mode of training. Eight American aloes (*Agave Americana*), also in huge Dutch flower-pots, finish the decoration of the lawn, and, it must be confessed, harmonize very well with the formal evergreens just described. A very good collection of orange-trees in tubs was disposed along the sides of the walks in the flower-garden: two of the myrtle-leaved variety were excellent specimens. All of them were pollarded in the style of the evergreen plants.

The soil of the place, being a mixture of fine vegetable mould, resembling surface peat-earth, with a considerable proportion of white sand, seems naturally congenial to the growth of American shrubs; and indeed rhododendrons, magnolias, and azaleas thrive exceedingly. In the flower-garden we saw Dahlias in great vigour and beauty: they were growing in the open border to the height of six or seven feet, and the flowers were nearly double the size to which they usually attain in Scotland, and some of them were of very brilliant colours. The roots are raised on the approach of frost in autumn, which is quickly indicated by the shrivelling of the leaves: they are kept over winter among sand, in the store-house, and are again planted out in the spring, when all risk of frost is over. The driest border and the poorest soil, are accounted best for dahlias.

Several kinds of tender plants were plunged in the open border for the summer; particularly the Peruvian heliotrope (*Heliotropium Peruvianum*), the specimens of which were uncommonly luxuriant, and, being now in full flower, spread

their rich fragrance all around. The European heliotrope (*H. Europæum*) is likewise not uncommon in the flower-borders.

In the fruit-garden we first saw pear and apple trees trained *en pyramide* or *en quenouille*, i. e. preserving only an upright leader, and cutting in the lateral branches every year. Trees pruned in this manner occupy much less room, and throw much less shade, than those to which we are accustomed at home. It is evident that they can, when thought proper, be placed much more closely together than usual: those before us were planted at distances of eight feet. They, at the same time, in general produce a reasonable proportion of fine fruit; some of the trees in this garden indeed were fully loaded. This pyramidal mode, however, is calculated only for countries not exposed to frequent violent winds: with us, it could not, probably, be adopted with any degree of success, unless in the most sheltered situations. Even here; at Bruges, where high winds are of unfrequent occurrence, some of the weaker trees had stakes to support them. These *quenouille* trees are here thought handsome or symmetrical; but to our eyes they appeared rather stiff and formal.

The north side of the fruit-garden is covered with a suite of glazed houses, consisting of five. In the centre is a stove or hot-house for the most tender plants; on each side of this is a green-house, for sheltering more hardy exotics during winter; and at each extremity is a house partly occupied with peach-trees, and partly with grape-vines. In these last houses there are now ripe peaches, and we understood that many dozens of that fruit had been gathered; but ripe grapes can scarcely at all be expected in these houses, the two kinds of fruit not attaining maturity at the same period of the season. The sashes had some time ago been removed, in order to allow free admission to the sun's rays and to air,—things

indispensably necessary for giving flavour to the peaches : the young grapes had thus suffered a sudden check, from which they are not likely to recover. Some of the vines are trained on horizontal trellises in the front part of the interior of the houses, and some on the rafters. There appeared nothing worthy of imitation in the construction of the houses ; and they seemed to be but indifferently managed. In the space of ground before the houses are ranges of pine-pits and melon frames ; neither of them deserving of commendation. The kind of pine-apple chiefly cultivated is the queen ; but the plants are very inferior to those which we lately saw at London, or which we commonly see in Scotland. One frame is dedicated to a collection of cockscombs (*Celosia cristata*), and these certainly form the boast of M. Bertrand's garden : they are of the dwarfish variety, but large or strong of their kind ; and in brilliancy and variety of colours, they can scarcely be excelled.

Succory.

About Bruges, succory (*Cichorium Intybus* *) is extensively cultivated, beds of it appearing in every kitchen-garden, and acres of it occasionally in the fields. This was a novelty to us ; and we received various accounts of the objects for which it is cultivated. One person said it was for the sake of the herbage, or leaves, which are given to milch cows : another told us, that the leaves are twice cut over in the course of the season, in order to make the roots swell ; adding, that though, when raw, the roots taste almost like dandelion, they are very palatable when boiled

* It may be noticed, that the French give the name of *chicorée* to endive, and distinguish succory as *chicorée sauvage*. The Flemings, however, use the terms *endyve* and *cicorei* as we do, and give the name of *wilde cicorei* to dandelion.

and stewed. There is no doubt that cultivation has, to a certain extent, altered the quality of this vegetable, and that both the leaves and the root of the garden succory are less bitter than those of the native plant. At our inn we were informed, that the plant is raised from seed every spring: the tender leaves are used in salads early in the spring: the full grown leaves are afterwards shorn once or twice for cows; and the roots are considered fit for use when they are of the size of small carrots or parsnips; they are scraped and boiled, and eaten along with potatoes, with a sauce made with butter and vinegar. We further learned, that during Buonaparte's sway, when colonial produce was either scarce and dear or entirely interdicted, the roots of succory, cut into little pieces, dried in an oven, taking care to avoid burning, and afterwards ground to a powder, were used by the common people as a substitute for coffee, and by those in better circumstances mixed with a certain proportion of real coffee-beans.

Garden of the Capuchin Friars.

We had seen a Nunnery in the morning; in the afternoon we paid a visit to a brotherhood of Capuchin Friars. By what chance this fraternity had been able to retain its mansion and garden during the purgation of the Revolution, we had no means of learning. The Capuchins profess the contempt of money: this really seems to be a poor establishment, and its poverty has perhaps formed its best security. The garden is evidently very old, and we found it under the management of an antiquated gardener, poorly habited, with a large hook-bladed pruning-knife appended to his button-hole, a dirty *white* apron*, and a greasy woollen cap on his head. He could speak only Fle-

* Scottish gardeners invariably use *blue* aprons.

mish, so that it was difficult to communicate with him. The garden is surrounded with high walls, the better aspects of which are clothed with vines. But though the plants are old and strong, they do not appear to be productive; they bore pretty evident marks of being injudiciously pruned; and this, at any rate, has been an unpropitious season. We found some trees of the orange-bergamot pear as standards, and others trained to the wall. Pears which the gardener called the *Casserine* and *Callebash* were much praised by him, as well as *Longue queue de Louvain*, which last seemed to us to be one of the *Blanquettes*, its wood resembling that of our English jargonelle. Our jargonelle, it will be remembered, is the *Epargne*, or *Grosse Cuisse-madame* of the Continent. The *Passe-colmart* was here in great perfection: this variety, we believe, originated in this part of Flanders, and has only of late years become known to the Parisian nurserymen. It is a late pear, but the fruit was already of a large size. It is fit for the table in the months of December and January, and bears a high character. A pear to which the gardener gave the name of *Cheneau* received also a high character; the fruit somewhat resembled our Gansel's bergamot. In this garden, we for the first time saw an Almond-tree planted as a standard; but it did not, this unfavourable season, shew any fruit. Besides the usual culinary crops, the garden contained large beds of some plants which are not commonly cultivated at home. One was Millet (*Panicum miliaceum* *), which is here called *hirz*, and is cultivated for the sake of the seeds, of which puddings are made. The other was Small Fennel-flower (*Nigella sativa*), here called *nardus-zaadt*, which, as the

* This, we believe, was a variety called African Millet, which requires less care in cultivation than the common kind, and the seeds of which are less apt to be devoured by small birds, while ripening.

gardener made us understand, is chiefly cultivated for use in medicine, though the seeds are also sometimes employed for flavouring particular dishes. *Nigella arvensis* is likewise occasionally cultivated for the sake of the seeds.

Agriculture, &c.

In the course of our evening walk, we were attracted by a novel appearance in husbandry ; the labours of the seed-time and the harvest seeming here to be united and cotemporaneous. We entered a field of luxuriant rye, part of which remained uncut, but a large proportion of which had been cut down this morning, (12th August). The crop had been carried aside ; well-rotted dung had been pretty liberally laid on the stubble ; the Flemish plough was now at work ; and, to complete this picture of industry and expedition, a man was actually engaged in sowing *knollen* (turnips) on the plowed portions of the same field from which the rye-crop had been reaped in the morning. In this favourable climate and early soil, the Flemish farmers very frequently raise two crops in the year on the same field ; the latter being generally some kind of green crop for their cattle, such as *raap* or rape (*Brassica Napus*), sown for the sake of the leaves, and *spurie* or corn-spurry (*Spergula arvensis* var.). In Scotland, two crops in the season can seldom be accomplished. If, however, the alacrity which we here witnessed were imitated, turnips might sometimes follow early potatoes. Turnip-seed may undoubtedly be sown with success late in the season, not only in the end of July, but even in the middle of August ; by which time, early potatoes might in general be profitably removed. The common white and yellow turnips would be proper for this crop ; the Swedish turnip would not have time to come forward. Late sown turnips, it may be

remarked, are not only exempt from the ravages of the *fly** (the feeding season of the animal being past); but it has been observed that, on account of their more vigorous state in November, they withstand the winter frosts much better than those sown early, proving equally hardy as the Swedish turnip.

The plough here used was light, and was held with the left hand alone of the ploughman: it turned over the surface merely; but the soil being naturally shallow, there seemed no motive for deep plowing, and at any rate a slight furrow was sufficient for a second crop. The kind of wheat cultivated is the common winter sort (*Triticum hibernum*), and also the red wheat (*T. turgidum*). Spelt, or the wheat raised by the ancient Romans (*T. spelta*), is likewise sown in a few places: the flour of this last is fine, and is said to be preferred for pastry. Some of the old pasture meadows have a rich clothing of grass, composed chiefly of *Poa trivialis*, *pratensis*, and *annua*, interspersed sometimes with large tufts of *Cyperus longus*.

We were now in the country where the Great Purple Trefoil, or Broad Clover (*Trifolium pratense* var.), was originally cultivated. It is here called *Meersche klaveren*, or marsh clover, because it is found to succeed best in their moistest fields. We saw some rich meadows, from which two crops or cuttings, from ten to fifteen inches high, had already been taken, and which would soon yield a third. These fields had been manured with *Dutch ashes*, which are considered as extremely advantageous to a clover crop, and are brought in vessels from Rotterdam by the industrious farmers of this country. Much broad clover seed is saved in Flanders, and exported to the more northern parts

* A small kind of beetle, the *Haltica nemorum* of entomologists.

of Europe. When a crop of seed is wished for, the field is only once cut for green food to cows, and the second growth is allowed to come to maturity. In favourable seasons, the seed is often produced in Scotland; but it has generally been found difficult to separate it from the husk, owing to the want of a proper machine for the purpose, which, however, might easily be procured. In such districts as East Lothian, and the Carse of Gowrie and Falkirk, the farmers might, very generally, save their own clover-seed, merely by railing off with a moveable fence, and reserving uncut, an eighth or a tenth of an acre of the first crop; or, if the second crop is thought to be more prolific in heads, and firmer in the stalk, by cutting the first crop from that portion of the field three weeks earlier than usual*.

Notwithstanding the distance at which we had now left the sea, *Plantago coronopus*, or bucks-horn plantain, which with us is a maritime plant, appeared on the sides of the pathways. This, it may be noticed, is regarded on the Continent as one of the small salad herbs, although it is entirely neglected by us. Sweet-flag (*Acorus calamus*), water-violet (*Hottonia palustris*), and Frog's-bit (*Hydrocharis morsus-ranæ*), plants not found in Scotland, and not very general in England, abounded in almost all the ditches; the latter only was in flower.

* While this sheet is in the press, we have had an opportunity of examining a sample of broad clover-seed, saved from a second crop, by Messrs Miller, at Newhouse, near North Berwick, Haddingtonshire, equal in quality to any imported seed; the past season (1819) having been very favourable for the purpose. On shewing the sample to eminent nurserymen and seedsmen at Edinburgh, who deal very extensively in the article, they regarded it as excellent Dutch seed, and declared that it was more plump and shining than any which they had lately seen. Instead of mowing and thrashing the whole straw, women and children were employed by Messrs Miller to pluck the brown or ripe heads, and one person was able thus to collect about 8 lb. of seed daily.

At Bruges, wood is the common fuel; but such fuel becomes so expensive, that every sort of substitute is resorted to by the common people. We saw quantities even of the stems of cabbages and the flower-stalks of turnips carefully dried for this purpose.

From Bruges to Ghent.

Aug. 13.—On the morning of the 13th August we set off for Ghent, by another fine canal, in a bilander or barge elegantly fitted up, with every kind of accommodation. The deck, shaded by an awning, was occupied chiefly by our own countrymen; the cabin was crowded by Flemish families, who shewed little inclination to mingle with their foreign visitants. The fore part of the vessel was furnished in a very complete manner as a kitchen; and, at 2 o'clock, dinner was served in excellent style. Even a dessert was not wanting, although this was but indifferent, consisting chiefly of the short-stalked cherry, known at home by the name of the *Kentish*, but undoubtedly of Flemish origin.

The white and the yellow water-lily (*Nymphæa alba* and *lutea*), and the yellow bog-bean (*Menyanthes nymphaeoides*), are extremely common in the canal, and they were now in full flower. Owing to the quantity of water displaced by the barge in its progress, the broad floating leaves of the former may be observed continually curling up and ducking under in a very pleasing manner. The water is uncommonly clear for a navigable canal; and fishes, apparently carp, may frequently be observed. The banks of the canal next to the water are decorated with several very showy herbaceous plants, particularly *Lythrum salicaria*, or purple-spiked loosestrife, and *Butomus umbellatus* or the flowering rush. Both of these are indigenous to Bri-

tain ; but another plant, rivalling them in size and beauty, and evidently peculiar to the Continent, occasionally presented itself as we glided along ; it resembled *Asclepias incarnata* *?

In casting our eyes over the country, we observed that the rye crop was universally cut, and in many places already removed from the fields ; barley harvest was likewise going on ; wheat was not cut, but very nearly ready for the scythe ; oats were still green.

As we advanced up the country, the banks of the canal became gradually higher ; rows of abele (*Populus tremula*) were common ; and we passed many extensive coppices of oak, birch, and alder. At last the banks became so elevated, that we could see only in the line of the canal ; and in this way, for nearly an hour, we were shut out from any general prospect, but enjoyed a vista view of the tower and steeples of the ancient town to which we were approaching.

GHEENT.

Early in the afternoon, we reached the far-famed capital of Austrian Flanders,—the seat of “ Old John of Gaunt, time-honoured Lancaster,” and the birth-place of the Emperor Charles the Fifth. The distance from Bruges may be about thirty miles. At the principal gate, where we had to exhibit our passports, the name of *Macdonald* seemed to electrify the officer ; he hurried through the forms, left his bureau, and heartily shook hands with all of us, in-

* This is a North American plant : but I copy from the original notes. Specimens of this plant, afterwards procured near Ghent, with many others which we collected, were unfortunately destroyed at the Custom-House of Leith in our absence. Having thus been deprived of an opportunity of examining many of our specimens in a leisurely way, we must necessarily speak with some diffidence about the plants which occurred.

forming us at the same time, that his ancestors were Scots. We took up our abode at the Hotel de Lion d'Or, kept by M. Pacquet-Wouters, near to a belfry, where those who are delighted with the air of Malbrook may hear it chimed every quarter of an hour.

We now became sensible of an evident improvement in the climate; we felt no cold winds nor evening chills; and a Fahrenheit's thermometer * indicated 68° when laid on the outside of the window at 10 P. M.

Green and Fruit Market.

Aug. 14.—Next morning, according to custom, we visited the green-market. Here we found a decided superiority in the appearance of the kitchen vegetables, compared with those which we had seen at Bruges or Ostend. The cauliflower, in particular, was very excellent, being exceedingly white, compact, and curd-like. Different varieties of French beans or haricots, were offered for sale in vast profusion; together with a beautiful sort of red kidney potato, specimens of which we thought it worth while to carry to Scotland.

The fruit-market is connected with the market for vegetables. We observed quantities of a fine-looking small plum, shaped like a cherry, and in colour resembling a mayduke when half ripe. This turned out to be the Mirabelle, which is here planted in hedge-rows. This variety affords the common stocks, on which the Flemish nurserymen graft their peach and nectarine trees.

* This was one of Mr Adie's pocket thermometers, very correctly graduated, and having three scales, Fahrenheit's, Reaumur's, and the Centigrade. The instrument was kindly presented to me by the maker as I was setting out on the journey.—P. N.

Botanic Garden.

We lost no time in repairing to the Botanic Garden, in the hope of acquiring from the superintendant correct information as to the private gardens and public nurseries near Ghent best worthy of our notice. In 1797, when Buonaparte every where established what were called Central Schools, he granted to the lecturer on botany at Ghent, the orchard of the suppressed Abbey of Baudeloo, for the purpose of forming a "school of plants." It is not of great extent, being, by guess of the eye, little more than three English acres; considerably less than the present Royal Garden at Edinburgh, were it cleared of some of the superfluous forest trees, which were originally planted for shelter, but which now encumber it. The collection of plants is considerable, and some of the specimens are admirable; but it is inferior to that at Edinburgh in the number and variety of curious plants.

On entering the garden, the most striking object is a monument to Linnæus, containing his bust, placed at the extremity of a walk, and appropriately overhung by an elegant weeping willow (*Salix babylonica*). In Scotland, the extremities of the shoots of this kind of willow, a native of the Levant, and more delicate than others of the tribe, are annually cut off or injured, the new wood not ripening sufficiently to enable it to withstand the rigours of our winter. Here, however, the entire shoots acquire sufficient maturity to enable them to resist the frost, and the pendulous ramuli continue at full length. This consecrated specimen rises nearly forty feet high, with a straight stem; and from this height its branches descend gracefully over the simple monument. The effect is beautiful, and is heightened by the circumstance of a row of Lombardy poplars

(*Populus dilatata*) rising to double the height immediately behind the willow. In front of this monument is an extensive collection of perennial herbaceous plants, occupying nearly a fourth part of the garden, and arranged according to the method of Linnæus, with large tallies indicating the classes and orders, and smaller ones telling the generic names. This department of the garden is, by way of eminence, termed *l'Ecole*. At this season of the year, the alleys which divide this "school" into beds are lined with rows of green-house and dry-stove plants; and the broad walk leading to the monument is decorated on both sides with rows of orange and pomegranate trees, and others generally kept in tubs or cases. All of these are closely pruned, so as to form round bushy heads. If the orange-trees produce a few flowers, they are picked off as fast as they appear: we saw, lying in the green-house, bushels of the leaves and twigs of these orange-trees, the result of a severe pruning which they had just suffered, and we were told that they were kept for the use of apothecaries.

A very fine specimen of the Mastic-tree (*Pistacia Lentiscus*, mas?) deserves attention. It is nearly 12 feet high from the walk, with a stem 15 inches in circumference. The head is large and bushy. The case bears an inscription, intimating that this plant has been dedicated by the managers to the memory of M. Van Haut, a young and promising botanist who died in 1805, and who bequeathed all his means and estate to the garden. In the same way, a specimen of *Borassus flabelliformis*, from Upper Egypt, and one of the rarest of the palm-tribe, is dedicated to the memory of M. Coppens, the first lecturer on botany here, and the planner of the garden.

Statues of Ceres and Flora, and busts of some of the principal early botanists of the Low Countries, are scatter-

ed up and down the grounds. A bust of Clusius is appropriately enough placed under the shade of a fine horse-chestnut tree (*Æsculus hippocastanum*), a tree which he first introduced into Holland and Flanders; but the effect is lessened by the conceit of planting potatoes around the pedestal, because (as the botanic gardener supposed *) Clusius was the first also who made known that esculent to the Flemings.

Two fine plants of a very curious variety of *Salix babylo-nica*, with the leaves curled up, "*foliis retortis*," attracted our notice. This variety was not produced in this garden, but, as we learned, was received, in 1815, from M. Cels, botanist and nurseryman near Paris. The Sumach-trees are tall, and now in full flower, a thing seldom to be seen in our most sheltered shrubberies. But the Larch (*Pinus Larix*), which flourishes so admirably on the hills of Scotland, has here a sickly aspect: the soil may possibly be too rich and too damp, but it seems as likely that the climate is too warm. As an evidence of the superiority of climate here, beyond what we can boast even in the south-west of Eng-land, it may be mentioned, that the beautiful *Commelina tuberosa*, var. *cœlestis*, which with us is treated as a stove plant, here remains in the open border all the year. Some of the old stools, or tuberous roots, we were told, perish during winter; but as the seeds ripen every au-tumn; there is a constant succession of young and vi-gorous plants. A border was now covered with it, and its brilliant blue flowers produced a fine effect. In the open American department, where a light heathy soil had been prepared, *Lilium superbum* appeared in great glory, producing large crowns of splendid flowers, and eclipsing

* Clusius himself informs us, that being at Vienna, he first received tubers of the potato from *Flanders*.

the beautiful tiger-spotted and Canadian lilies (*L. tigrinum* and *L. Canadense*), which were also in flower. The false acacia (*Robinia pseud-acacia*), which with us appears commonly in the form of a large shrub, or at best as a small tree, is here nearly 50 feet high, and, of one tree, at three feet from the ground, the stem measured 4 feet 9 inches in circumference.

A department is set apart as a winter garden, or as an evergreen grove, the trees consisting of hollies, savines, cypresses, pines, and evergreen oaks.

There is a large pond for aquatic plants, supplied with water from the river Lys, which washes the inclosure wall on one side of the garden. During the domination of the French, this river Lys gave name to the Department in which Ghent is situate.

The *rosary* of this garden is extensive. The roses are in general trained tree-wise, from three to six feet high; those with slender stems being furnished with stakes. This mode, it may be noticed, answers many kinds of roses better than keeping them clipped down like bushes.

There is a quarter appropriated to fruit-trees, especially pear-trees, of which the collection is ample, having been furnished by MM. Thouin of the Jardin des Plantes at Paris. They are planted close, or at six feet apart; but being trained in the pyramidal form or *en quenouille*, this distance proves sufficient, at least where fruit is not the principal object. Some of the more slender stems were furnished with stakes; but high winds are not here of frequent occurrence. Several of the trees shewed a sprinkling of fruit, and we were told that in some seasons they are much more productive. A large specimen of the weeping cherry, standing on its own roots, is distinguished by the whole plant inclining to droop, and by the fruit having long stalks. Against the garden wall are

trained some old vines, in the manner of peach-tree *riders*: they are tall and cover much space, but this year they promise few grapes.

The hot-houses are extensive, and have evidently been erected at different times. They consist of a lofty old central green-house for tall plants, with an ordinary green-house and a dry-stove on the right; and other two houses on the left, calculated for the more tender kinds of plants*. Each of the divisions is furnished both with a thermometer and a barometer. Few of the plants now remained within doors, almost all having been set abroad for the summer months. Even the dry-stove was empty, and the succulent tribes were fully exposed to the air: by this sort of treatment, many species of the Aloë and Cactus are here induced occasionally to put forth their flowers, while in England, where they are kept constantly under cover, these seldom or never appear. Two specimens of the American Aloe (*Agave Americana*) are large, and may probably flower in a few years. Four specimens of the Jamaica pepper-tree (*Myrtus Pimenta*), however, continued under

* *Ground-Plan Sketch of the Hot-Houses in the Botanic Garden, Ghent, from Mr Hay's note-book:*

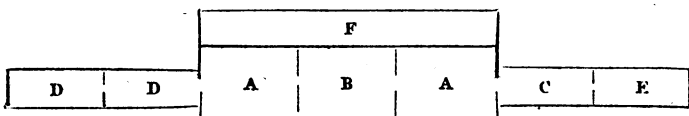

A, A,	Green-houses, each 44 feet,	=	88.0
B,	Green-house,	40 do.	40.0
C,	Green-house,	40.6	40.6
D, D,	Stoves, each,	40.6	= 81.0
E,	Dry stove,	40.6	40.6
	Length,		290.0

F, Shades.

Breadth of large Green-house, 30 feet; of the Stoves, 20 feet.

shelter : these deserve mention, on account of their unusual size, being from eight to ten feet high.

Gardeners may perhaps be excused for taking notice of minutiae, if they be connected with horticultural arrangements.—In some divisions of this garden the scientific name of the plant is painted on a tally, the head of which is of tinned iron, and the stalk of wood : in other places, the tallies consist merely of triangular pieces of roof-slate, on which is cut or deeply scratched, in Roman numerals, the number of the plant in the garden catalogue.—The usual material used for tying up the plants here, consists of the stalks of *Juncus effusus* ; great quantities of which were at this time lying in the green-house, being gathered at this season when in vigour, and quickly dried, so as to preserve the tenacity of the fibres. They answer the purpose very well, and perhaps have a less formal appearance than strands of bass-matting.

From M. Mussche, the principal gardener, we procured a printed catalogue of the plants cultivated in the garden *. For what reason we could not divine, M. Mussche seemed disinclined to give us information as to any fine private gardens in the environs of Ghent. On inquiring for the best example of a public nursery and a sale kitchen-garden near to town, we were recommended by him to visit the pepiniere of M. Nicholas De Cock in the neighbourhood of the Vieux Bourg, and the marais of M. Smedt at the end of the Rue des Meuniers.

De Cock's Nurseries.

In the afternoon, accordingly, we visited the gardens

* Hortus Gandavensis, ou Tableau général de toutes les Plantes exotiques et indigènes, cultivées dans le Jardin Botanique de la ville de Gand ; par J. H. Mussche, jardinier en chef. 1817.

and nursery-grounds of M. de Cock. We found that they were on a very limited scale, and kept almost entirely by his own labour. It may be noticed, that in some places the divisions were made with hawthorn hedges trained to slight trellises, forming a thin and slender hedge, but one which must very speedily attain sufficient height. There was a considerable collection of apple and pear trees in a fruit-bearing state, and the owner appeared to have a pretty correct knowledge of the numerous varieties which constitute his stock. He proved of an obliging disposition, and very willing to communicate information. He prepared for us a written catalogue of the best fruit-trees in his nurseries, and more particularly of the kinds to which he gave the preference †.

Having inquired which of the fruits he regarded as in any respect remarkable, or as new, and of Flemish origin, he particularised the following.

Among Peaches, the *Pêche Quesnoy* he described as being of a dark-red colour like beet-root, and a good kind. The white *Grosse Mignonne* he regarded as one of the very best in Flanders. The *Grand Hamelinck* (thus the name was written to us,) he considered as having originated in the Low Countries, and mentioned that the fruit had a rose-red hue on one side. The *Brugnon blanc*, or White Nectarine, received from M. de Cock a high character for flavour and size,—more perhaps than it deserves, if it be the same variety that is known in Scotland by the name of New White Nectarine: the tree is easily distinguished by the foliage being of a lighter green than usual. He spoke of the *Brugnon imperiale* as being a very large fruit, of a red colour: we had no opportunity of seeing it.

† See Appendix, No. I.

The *Brugnon paderel** he mentioned as being of Flemish origin, but only fit "pour des compôtes."

An Apricot which he called *Le Grand Machol* (marchal?), he described as a large fine fruit, and added, that the tree requires a wall. A spotted apricot called *Le Crapaulé*, may probably be Flemish, and was also recommended as good.

Among Plums, the *Longue Bleau* was the only novelty. It resembles the Blue Magnum in colour and in length, but is much narrower or has less flesh; and it frequently produces two kernels or stones. It is very common here, and is considered as an original production of this part of the country. It is scarcely so good as the blue magnum, What our conductor styled the *Mirabelle verte* looked extremely like our Green Gage.

The pear-trees are numerous; but we saw fruit on only a few. The pear here called *Saint Laurent*, is also named Jargonelle: it resembles the jargonelle of Scotland, but is not the same variety. M. de Cock praised very highly for a wall the *Bergamotte Crasanne*, and we heartily joined in the commendation. He spoke of the *Grande Bretagne* as a very large winter-pear; but we could not ascertain the variety. The *Mansuette gris*, which resembles the former, seemed to be our Grey Achan. The *Colmar d'Hiver* he recommended for a wall; and the *passe-colmar* (a recent production) for training as a standard. The *Poire Capucin* he spoke of as fit only for stewing. The *Angelique de Bourdeaux* he noticed as remarkable for keeping firm and good very long, and for being abundantly produced on standards. One

* We know not the etymology of *paderel*, but so the name was spelled to us. Perhaps *pastorale*?

called *Marquise d'Automne* he seemed to consider as a new kind, with which he was not well acquainted. Another, called *Delice d'Ardeмпont* he stated to be a large winter-pear of excellent quality, also gained from the seed of late years. He spoke likewise of a *Beurré d'Ardeмпont* as a new acquisition. Ardeмпont is a village near Tournay, distinguished for numerous gardens, in which the more hardy fruits are cultivated with great success. A new pear, which has not yet received any other denomination than *Nouvelle gagné*, M. de Cock did not seem inclined to boast of; he spoke of it as an autumnal pear, but we could not procure a specimen. The *poire de Louvain* he mentioned as a small summer pear, tolerably good. He enlarged on the beauty and excellence of the *Beau present*, which he said might be styled "Bon present."

The Apple-trees were chiefly Calvilles, Rennets, and Carpandies (Courpendues), and did not seem to require particular notice.

M. de Cock likewise very obligingly mentioned to us the country-seats and gardens in the neighbourhood of Ghent, which he considered as of superior merit, and well deserving of our attention; particularly those of the Baron de Vroelande at Leerne, of M. Meulemeester, banker in Ghent, and of M. Van Wousteyne at Wouvelghem.

Aug. 15.—To-day (being Friday) we were somewhat surprised to find the shops of Ghent shut up, and every body gone to church. Those of whom we inquired the reason, expressed no little wonder, on the other hand, at our heretical ignorance of its being the Fête d'Assomption. Splendid processions of Our Lady were passing through the streets, and high mass was to be celebrated in the Cathedral of St Bavo. Thither we of course repaired: we

found the interior of this beautiful Gothic church already crowded; and we had not remained long till the bulk of the people became prostrate, even the files of soldiers kneeling while they presented arms; drums were beating, trumpets sounding; priests gorgeously clothed, were marching and chanting, while little boys were swinging their censers and sending perfume all around;—the host was now elevating! While Mr Macdonald and I were wondering at this grand ceremony, we suddenly missed Mr Hay; and on rejoining him without, we found him not a little scandalized at the whole scene, which was certainly a striking contrast to “plain presbytery,” and to our simple Scottish forms.—We now, therefore, made our way to the garden of M. Smedt in the suburbs.

Smedt's Garden.

This is a pretty extensive market-garden, and it seems to be under judicious management. At the entrance, a hedge of dogwood, of the green variety, (*Cornus sanguinea* var.) was rather a novelty. Several large beds were occupied with silver-skinned onions, which appeared very clean and healthy, and likely to swell to a considerable size. The plants were nowise crowded; but we understood that they had been thinned, by *drawing* the young onions for the market. We here saw a quarter planted with the true dwarfish globe-artichoke (*Cynara Scolymus* var.), which is a distinct variety from the French artichoke, the kind commonly cultivated with us. The red beet of this garden appeared to be of the most genuine quality, and was indeed the finest any of us remembered to have seen. Several large beds of Endive, for successive crops, were very excellent; in no case did we observe that it had *run*, or shown an inclination to throw a flower-

stalk : the summer weather seems to be here so uniformly mild and genial, that the plants meet with no check in their growth, but swell uniformly and uninterruptedly : with us they are often checked, by cold and even frosty nights ; and one striking effect of such checks (as remarked by Mr Macdonald) is to force the plants prematurely into a flowering state.

Besides raising vegetables for the market, M. Smedt applies himself to the production of several kinds of garden seeds. We observed beds and rows of Lettuce, Onion, and Purslane. The lettuce, we found, can here be sown in the spring, and will yet perfect its seed the same year. The Berlin, the white and the brown Dutch lettuce were here ripening their seeds close by each other ; it seems no-wise surprising, therefore, that mixtures should take place, and endless hybrid sub-varieties be produced. The confusion of sorts, not only in the case of lettuce, but of endive, beet, onion and carrot, is, we believe, greatly increased from this circumstance,—that agents for seedsmen often travel through Flanders and Holland, and pick up small parcels of these seeds from great numbers of different market-gardeners and others, many of whom pay little or no attention to the separation or discrimination of varieties.

A wide-spreading vine, of the Frankenthal variety, completely covers the roof of a large cow-house, on which it is horizontally trained. The stem rises eight feet, before branching ; and at three feet from the ground, it measures $10\frac{1}{2}$ inches in circumference. This fine plant is now unfortunately neglected, and is fast going to decay.

Ghent Exhibition.

The afternoon of this day we dedicated to an inspection of the exhibition of paintings by living Flemish artists,

which was now open, and crowded to-day by the common people in their holiday dresses. To those who take pleasure in contemplating the costume of a country, this would have been a charming opportunity. To us the treat was in a great measure lost: we remarked only that the colours of the dresses of the lower orders were generally glaring, and that these colours were often most unharmoniously associated, or rather violently contrasted, in the upper and lower garments of the same individual. The exhibition of paintings is held, every third year, under the direction of the Royal Academy of Ghent, in the hall of the *ci-devant* College of Augustins, which was granted by Buonaparte for this purpose. It will not be expected that we should give a detailed account of the paintings, or pass judgment upon them. A very few remarks will suffice to give some general idea of the exhibition.

The number of paintings was great, occupying a long gallery, besides several small rooms, for models, pieces of sculpture, and other exercises of the young academicians. The list of artists and amateurs who had contributed the pictures was also very ample. In short, this seems still to be a country of painters, although the glory of the Flemish school has long since passed away. Many belonged to Ghent, but many likewise to Brussels, Bruges, Malines, Antwerp, and other places. The number of historical pieces was proportionally great; at least, so it appeared to us, who had been accustomed to see only two or three in each Edinburgh Exhibition*. One of the largest dimensions was by

* It is impossible not to regret, that the exhibitions of the works of living Scottish artists should seem to have been given up at Edinburgh. It was perhaps too much to expect, that the artists and amateurs of Scotland could furnish the walls of Raeburn's large room with works of merit every year; but we are persuaded, that an exhibition of triennial recurrence, like that of Ghent, would be eminently useful and successful, especially if placed

Van Bree of Antwerp, and represented the devoted heroism of the burgomaster Van Werff during the siege of Leyden, a subject which has been before treated, by masterly pencils, and which still seems a favourite. Another by the same painter represented the affecting story of Joanna Sebus, which has been commemorated in one of the odes of Goethe*. The Virgin Mary supplicating the High Priest in the Temple of Jerusalem, by Van Huffel of Ghent, appeared to us to be a picture respectably treated. The Prince of Orange wounded at Waterloo, by Odevaere of Brussels, was a tolerable painting, of large dimensions, the principal figures being the size of life. A piece entitled "l'humanité Belge," by Professor De Cauwer, of the Ghent Academy, seemed happily conceived. It represented the interior of a farm-yard, and the farmer, his wife, sons and daughters, assisted by a Scots Highlander, who had been only slightly hurt, anxiously engaged in endeavouring to succour wounded soldiers of different nations,—Flemish, Prussians, English dragoons, Hanoverians and Brunswickers. The way in which our Highland countryman was thus introduced, was probably intended to convey a delicate and friendly compliment; for the Montagnards d'Ecosse are held in great estimation in the Low Countries. In another piece, by J. F. Thys of Brussels, a wounded Scots Highlander is the most prominent figure, with a very pretty young woman carefully binding up his arm. The same painter has, in another picture, given a lively representation of the meeting of Wellington and Blücher at La Belle Alliance in the moment of victory. The landscapes were numerous: some of the best were by Dominique de

wholly under the direction of a few of the distinguished connoisseurs of the northern capital.

* Works, Stutgard edit. 1816, vol. ii. p. 33.

Bast, an amateur in Ghent. Two flower-pieces in oil colours, by Desprets of Brussels, attracted our horticultural eyes: very judiciously, the flowers were those of most common occurrence, so that every one could judge of the similitude. A bouquet detailed with botanical precision in water-colours, by Sauvage of Tournay, reminded us of the style of our excellent townsman P. Syme.

Certain subjects are prescribed to the élèves of the Academy, and honorary medals awarded to those who excel in treating them. The competition paintings were placed near each other; one subject was Nymphs visiting the Temple of Diana, which had produced three competitors: another subject was a wounded soldier received by his family after the battle of Waterloo; this had excited no fewer than six competitors. All of them must doubtless be very young artists, for even to our uninitiated eyes it was evident that there was still much room for improvement.

The decorous behaviour of the numerous spectators, many of whom were of the lowest orders of society, deserves our highest commendation. It is mortifying to reflect, that the same freedom of access to a gallery of paintings and sculpture, could not, with safety to the works of art, be conceded to such a promiscuous assemblage in our own country.—When will this reproach be wiped away?

Agricultural and Botanical Society.

Aug. 16.—Next morning we waited on M. Verbeeck, Secretary to the Agricultural and Botanical Society here. To him we had a letter of introduction from the Right Honourable Sir John Sinclair, Bart.; and with pleasure we take this opportunity of mentioning, that the unceasing labours of our distinguished countryman, in promoting the knowledge of agricultural improvements, seem to be

duly appreciated in this part of the Continent. M. Verbeeck presented us with copies of the latest publications which have been issued by the Ghent Society * ; and kindly offered to introduce us to M. Van Hulthem, President of the Botanical Society, and to M. Van Hoorebeke, the most zealous practical botanist at Ghent.

The Agricultural and Botanical Society was instituted in 1809. It holds annually two Festivals of Flora ; one soon after midsummer, called the Salon d'Été ; the other about midwinter, called the Salon d'Hiver. At these *Salons d'exposition de fleurs*, the cultivators, both amateur and professional, assemble from far and near, in great numbers, almost every one contributing something to the general show. The public authorities, at the same time, give their countenance and support to these meetings. The flowers exhibited are most commonly planted in flower-pots ; so that they arrive unfaded, and, by a little attention to shading and watering, continue in full glory during the exhibition, which generally lasts for three or four days. An honorary medal is awarded at each meeting. By a pleasing fiction, the flowers alone are regarded as competitors, and the successful plant is said to be "crowned." The crown is bestowed on the plant which is declared, all circumstances considered, to be the finest production of the *salon* ; the excellence sometimes depending chiefly on the rarity or novelty of the plant, and sometimes on the size and splendour of an individual specimen of a well known species, indicating superior culture and treatment.

* "Discours sur l'état ancien et moderne de l'Agriculture et de la Botanique dans les Pays-Bas, par M. Van Hulthem, Juin 1817."—"Extrait du Discours prononcé au Salon de Flore à Gand, le 29 Juin 1817, par M. Cornelissen," &c.

The last summer festival was the seventeenth: the *salon* was opened on Sunday the 29th of June, and closed on the 2d of July.

The following are the plants which have hitherto been crowned at the different summer and winter festivals.

<i>Summer.</i>	<i>Winter.</i>
1809, <i>Plumeria rubra</i> .	<i>Erica triflora</i> .
1810, <i>Coffea Arabica</i> .	<i>Rosa muscosa</i> .
1811, <i>Gardenia Florida</i> .	<i>Camellia Japonica</i> , double white.
1812, <i>Pæonia chinensis</i> , double white (<i>P. albiflora</i>).	<i>Limodorum</i> (<i>Bletia</i>) <i>Tanker-</i> <i>villia</i> .
1813, <i>Erythrina coralloden-</i> <i>drum</i> .	<i>Pæonia suffruticosa</i> (<i>Moutan</i>).
1814, <i>Ixora coccinea</i> .	(No exhibition).
1815, <i>Protea speciosa</i> .	<i>Musa coccinea</i> .
1816, <i>Kalmia latifolia</i> .	<i>Strelitzia reginæ</i> .
1817, <i>Nerium coronarium</i> .	

Amateurs or others intending to visit Ghent, may perhaps like to know the names and residences of the proprietors of those crowned plants. We shall therefore mention both, as far as our information extends. The *plumeria* belonged to M. Du Coulombier; the *erica* to M. Lebegue, dealer in plants near Ghent; the moss-rose and *limodorum*, to M. Mussche, superintendant of the Botanic Garden; the *camellia*, to M. Mortier; the *moutan* and *kalmia latifolia*, to M. J. Van Aken; the *musa*, to the Baron Baut de Ramson at Wanneghen; the *strelitzia*, *gardenia* and *nerium*, to the Baron de Vroyelande at Marie-Lerne; the coffee-tree, to M. Lievin Bauwens, manufacturer in Ghent; the *pæonia albiflora* and *protea*, to M. Van Cassel, nurseryman near Ghent; the *erythrina*, to M. Van Berghe at Lerne; and the *ixora*, to Madame Vilain Quatorze, near Wetteren.

Most of these plants are of great beauty, and some of them are very seldom seen in flower. In the case of the moss-rose, however, the Society must have been influenced by the consideration of the plant having been exhibited in full flower at the unusual season of midwinter. We may add, that all of those plants have occasionally produced their flowers in Britain. Quantities of some of the finest and most fragrant of them are yearly prepared for the London market, by the active and tasteful nurserymen near the capital, incited by the high prices readily procured for them; particularly of the *Ixora coccinea* and *Gardenia florida*, which are forced into flower in the spring months, by subjecting them to a considerable degree of *moist* heat.

We may here notice, that an ornamental variety of *Pelargonium inquinans*, with double flowers, is very common at Ghent, no fewer than ten different competitors having exhibited flowering specimens of it at the last festival: this variety, we believe, has not yet reached Scotland.

Having ordered a carriage we now set off, by the Port of Courtrai, for the villa, at Maltebrugge, of M. Meulemeester van Aken, the principal banker in Ghent, and for the country seat of the Baron Dubois de Vroeylande at Marie-Lerne. The road on both sides was lined with large forest trees, forming apparently an interminable avenue, of invariable straightness, and perfectly flat.

Villa of M. Meulemeester.

We soon reached M. Meulemeester's, and readily obtained permission to view the garden and grounds. This has, at one period, been an elegant villa, and formed at very considerable expense; but it is not at present dressed with that taste and care which it merits. The chief gardener;

who accompanied us in our walk, was in a still more miserable plight as to clothing than the intendant of the Capuchin's garden at Bruges; he had no stockings, and straddled along with heavy sabots or wooden clogs on his feet; the mere wearing of which would certainly prove a heavy punishment to a gardener of Scotland. He spoke only Flemish; so that our means of communication were very limited: we could, however, from his handiworks, easily discover that he was far from being thoroughly acquainted with his business.

In place of walls or hedges, the fences here, and in most other gardens in the Low Countries, consist merely of canals or broad ditches full of water. These are very effectual for the only purpose for which they are wanted, the exclusion of intruders,—shelter not being required; and they are, at the same time, very pleasing, as the view of the country around thus remains uninterrupted. These canals were at this time ornamented with the flowers of arrowhead (*Sagittaria sagittifolia*) and of the frog-bit already mentioned, two aquatics which are rare in Britain, but here extremely common. They abound with fish, especially carp, which we could see every where swimming about, some of them of considerable size, and “silvered o'er with age.” In the lawn near the house, stands a fine specimen of the deciduous cypress (*Cupressus disticha*), about 20 feet high, and with a stem more than 3 feet in circumference. The walnut-trees were here covered with fruit, and had made strong shoots, of more than two feet, this season. Several very fine specimens of the variegated elm attracted notice; they are grafted on the common elm, and are more than 30 feet high. In the *bois* of this villa is a serpentine walk, about 300 feet long, covered with hornbeam trained to a vaulted treillage. This leads to an artificial cave, which is

fantastically paved with the metatarsal bones of sheep. We afterwards come to Pan's theatre: this is wholly formed of hornbeam trees and bushes, which the shears have curiously tortured into the appearance of a stage, with side-scenes, and of front and side boxes, and parterre or pit. Leaving this extravagance of the gardening of the Pays Bas, we return towards the house by an avenue of oriental planes, the finest which we ever saw. The trees are in general about 70 feet high; they are trained up, as if they were common ash or beech, to the height perhaps of 40 feet, and the trunks are quite clean and healthy.

In the garden we observed some wall and espalier trees, chiefly peaches and pears, trained to two main horizontal branches, situated near the ground, and with upright branches proceeding from these, in the way we sometimes train currant-trees against north walls in Scotland. The fan mode of training was however preferred.

Among the implements of gardening, we remarked a dibble calculated to make nine holes at once, at equal distances, for planting pease, beans, or haricots. Such a dibble is well suited for this garden; but it could only be used successfully in light sandy soil, and in very flat situations.

There is a greenhouse for giving shelter to a collection of orange-trees, and of similar plants, during winter. With us, during the summer season, the greenhouse, although without its proper inhabitants, is kept not only neat and clean, but is decorated with pots of cockscombs and balsams. Here, however, the house was not only destitute of temporary ornamental plants, but filled with lumber and rubbish, trusses of straw, old barrels, and broken flower-pots. There are three hot-houses; a central high-roofed stove, and two lateral houses of smaller dimensions. These

houses consist almost entirely of glass in front, and partly in the roof. But the roof glass slopes so little, or rises so near to the perpendicular, as to cover a space only of about four feet; the rest of the roof is slated. At the same time, the slated part of the roof is of a concave shape, and the upper part projects as far forward as the front of the sliding glass. In this way it happens, that by 11 A. M. (the hour at which we examined it, 16th August), a shade three feet broad is cast over the glass. All the roofs of hot-houses on the Continent which we have hitherto seen, partake more or less of this concave or projecting structure. The motive doubtless is, to guard as much as possible against the destructive effects of the showers of large hail-stones, which much more frequently occur in continental countries than in Britain. There are two pine-pits, of small dimensions, and without any provision for fire-heat. The pine-apple plants were not in a flourishing state.

About mid-day we proceeded towards Lerne, which is about ten or twelve miles from Ghent. We passed through a rich country, well clothed with trees. Oaks and beeches have been alternately planted by the road-side. In general, the oaks are pollarded, the cuttings being much in demand for fuel. Long and spiny shoots of bramble were in some places tied around the stems of young trees situated near the margin of the road, evidently to save them from being injured by droves of cattle passing along. There are few inclosures. Divisions are sometimes made by ditches; sometimes by rows of fruit-trees. All the fields are small; but even in what appeared to be very small fields, perhaps of two or three acres, we were, at first, rather surprised to observe perhaps five or six different kinds of crops,—rye, buckwheat, pease, potatoes, clover, flax. It turned out, that the ground occupied by each of these

different crops was in reality a distinct and separate property, the small field having probably fallen to be partitioned among six heirs, according to the modern French law of inheritance, by which, after the pattern of the ancient gavelkind of Kent, each of the children, male and female, is entitled to an equal share of the father's property in land. Several large fields of sown broom (*Spartium scoparium*) presented themselves. This kind of crop was to us in some measure a novelty. We learned that the broom was sown in poor sandy soils, such as prevail here, chiefly with the view of improving them; but that the young flower-buds, gathered in the spring, are often used as a pickle, and as a substitute for capers.

We afterwards passed several large copses, principally of oak. None were of ash (*Fraxinus excelsior*) although this tree would here prove admirably suited for the purpose. At one place we saw a copse-wood composed wholly of Spanish chesnut (*Castanea vesca*). There were also several extensive plantations of tall forest trees. Of the resinous family, the Weymouth pine (*Pinus strobus*) is here the favourite species; it adorns the country very much, towering above most of its neighbours, and completely displaying its long and slender foliage. The Norway spruce (*Abies excelsa*) is likewise pretty common. The Scots fir (*Pinus sylvestris*) occurs here and there; but it makes a deplorable figure, being pruned up in the Flemish style, like an elm or an oak,—treatment from which its nature is abhorrent. We did not see a plant of the Stone-pine (*Pinus pinea*), nor of the Cluster-pine (*P. pinaster*), although, as remarked by Mr Macdonald, the country is excellently adapted for the growth of these species. Small orchards generally form appendages to the whitened and comfortable-looking cottages on the road-side. Cherry-

trees are common; and we here found the short-stalked variety under the name of the Cherry of Bruges. The apple and pear trees, with very few exceptions, were at this time loaded with fruit: the former are generally middle sized standards; the latter are frequently of a beautiful pyramidal shape. Such cottages and orchards, however, are not numerous in this part of the country.

Place of Marie-Leerne.

The house of the Baron Dubois de Vroeylande at Marie-Leerne is a fine old Flemish chateau. From engraved views and plans of the mansion-house and grounds, which were shewn us in the library, we perceived that, in past days, the whole had been laid out completely in the formal Dutch style, with embroidered parterres and knots before the door. A great change had been attempted, some years ago, in imitation of the English style. A grass lawn has displaced the embroidered borders; and vast quantities of earth have been moved, so as to produce the appearance of banks, sloping gently to a beautiful expanse of water. Owing to the forming of these slopes, the trunks of some fine old walnut-trees have been partly buried, greatly to their disadvantage. We measured the stem of one grand tree, and found it to be no less than 9 feet 3 inches in circumference, at two feet from the surface; after ten feet of clear bole, magnificent branches are sent off, and extend widely on every side.

The grandeur and beauty of this baronial seat, consists, in our opinion, in a vast meadow, spreading itself under the windows of the house, to the extent of several miles,—perfectly level,—surrounded with large trees,—and inclosed by a very broad canal, communicating, we believe, with the “lazy Scheldt,” on whose banks we were now sojourn-

ing. On the rich pasture of this meadow were grazing several hundred fine cows, chiefly of black and white colours, belonging to the inhabitants of the neighbouring villages,—forming, altogether, one of the richest cattle scenes that can be imagined. Completely, therefore, do we differ from Este, who, somewhere in his Journal, alleges, that “cattle make no part of the charm of the leafy landscapes of Flanders.” We passed through a large additional detachment of villagers’ cows on their way to this remarkable meadow: each had a piece of basket-work tied over its mouth, which, while it nowise impedes the animal’s breathing, effectually prevents its doing any injury to the trees in the avenues, in going to and from the pasturage. The interest of the scene was at this time heightened, by the lowings of this detachment meeting with regular responses from distant parts of the meadow.

The garden is laid out with some taste; but it was not, at this time, in good order. The Baron was now at Brussels attending the Court; and his absence might, perhaps, account for some remissness in regard to neatness, if not excuse it. A few statues, all of stone, appear in the pleasure grounds and garden; and are judiciously disposed. The collection of ornamental flowers, both hardy and tender, is very considerable. Our attention was rivetted by some fine double-flowered dahlias, now in perfection in the open border; they were of different colours, but chiefly pale and dark purple. A variety of *Rosa Indica* with variegated flowers, was new to us; and a specimen of *Digitalis sceptrum* surprised us by its great size, being about ten feet high. The *Angelica-tree* (*Aralia spinosa*) was large and beautiful in the open border, any injuries of winter being quickly remedied by the bright and warm summer of this country.

The green-house plants were, at this season of the year, ranged along the sides of the walks, in the garden and shrubberies. In the centre of a broad cross-walk, was placed a collection of large orange-trees, about twenty in number: the specimens were generally good, but, as we should think, much injured by the shears, being cut as unmercifully as a hawthorn hedge in the Lothians. Of small orange-trees there were several hundreds; these last were intermixed with plants of oleander, pomegranate, sweet bay, and laurustinus, all pruned up in the Flemish fashion, and with round bushy heads.

The hot-houses form an extensive range. The gardener's lodge is situated at one end, and is thus in connection with the whole. The front of the lodge is adorned with two plants of *Bignonia radicans*, rising twenty feet high, and extending as many feet in width: they were at this time clothed with their large and elegant scarlet flowers, producing a brilliant effect.

The principal hot-house contains three divisions. The middle division is lofty in the roof, from 25 to 30 feet high, and is appropriated to stove plants of the largest size: here, for instance, is a dragon's-blood tree (*Dracaena draco*) about 25 feet high, and a very tall specimen of *Cyperus papyrus* of the Nile, the plant which afforded the papyrus of the ancients. The other two divisions are from 16 to 18 feet high, and are partly occupied with tender ornamental plants, and partly with ananas. A very fine specimen of the prickly pear (*Cactus opuntium*) was here trained to a slight trellis: the branches extended six feet wide, and rose fully four feet high. The pine-apple plants did not appear very healthy, nor likely to yield perfect fruit. In all of these stoves, the flues are led along the interior of the house, nearly in the mode recommended in this country by

Mr Hay, not sunk into the back-wall, as used formerly to be the case.

There are two small vineries, which did not afford us much satisfaction. The vines are planted in front, on the outside of the house. Every year a new set of wood is taken into the vinery: the wood produced this year, is trained upright on an exterior trellis, and is next season laid down to a sloping trellis, and made to yield its fruit within the house. The wood which has once been forced, is cut entirely out; and from the same roots, new upright shoots are annually required. The sashes were now removed, but the shoots which had been forced in the spring remained; and a bare inspection was sufficient to satisfy any one, that they could have afforded but few grapes, the wood of last year having been extremely imperfect. The exterior upright shoots of this season were, at the same time, in a very backward state; and there was now (16th August) little prospect of their acquiring maturity this year. Were the climate, in the early part of the summer, sufficient to produce shoots approaching to the woody state, the more completely exposed to cold weather such shoots afterwards remained, the more hard and firm would the wood become, and the greater would be the prospect of success in forcing. But, even in the neighbourhood of Ghent, at least in unfavourable seasons, like that of 1816, the shelter of a wall does not always ensure the ripening of the wood.

There are four peach-houses, of small dimensions, and with low roofs. The trees are trained to the back wall; they are in but indifferent order, and infected with the white insect. In front of them are pits filled with tanners' bark, containing some succession pine-apples, and also a few ornamental plants. The practice of thus forming pits in peach-houses (too prevalent in our own country), must,

especially where the houses are of small dimensions, necessarily prove injurious to the trees planted against the back-wall, by cramping their roots, which would otherwise have the liberty of pasturing on the space occupied by the pits.

The Orangery, or principal green-house, is very large; it is completely in the old style, with upright glass and a slated roof. We saw it to great disadvantage; it seems, at this time, to be used as a temporary barn, being filled with unthrashed rye, and bundles of straw.

The walls of the garden are extensive: they are of brick, very well built, and have a coping of tiles. Like almost all the other fruit-walls which we have hitherto seen, they are furnished with coarse wooden treillages, to which the branches are tied by means of strands of different substances. They are in general high, perhaps from 15 to 18 feet, particularly on the north and the west. One part is appropriated to vines, which have seen many years, and still appear healthy; but, this year, they shew little fruit. Another part is dedicated to peach, nectarine, and apricot trees. These are much too crowded on the wall, and they do not in general appear healthy; the soil indeed seems rather unpropitious to peach-trees, of which we did not observe one in a flourishing state. Some of these are of considerable age, but have very little new or bearing wood: many more are young trees of small size; for it seems to be a rule among Continental gardeners frequently to renew the peach-trees. Here and all around Ghent, the soil is too light and sandy for pear-trees; and it is an undoubted fact, that far larger and better specimens of the finer French pear-trees (Crasanne, Colmar, St Germain, &c.) may be seen trained against walls in old gardens in Scotland, than are to be found in the neighbourhood of Ghent.

Just as we had concluded our examination of the Baron's garden, it began to thunder and to rain. In passing along the fields, our attention was attracted by one of the Flemish ploughs calculated for giving the slight furrow previous to sowing turnip and rape as a second crop. Mr Hay made a hurried; but pretty accurate, sketch, which is subjoined, with the explanation and measurements extracted from his note-book.

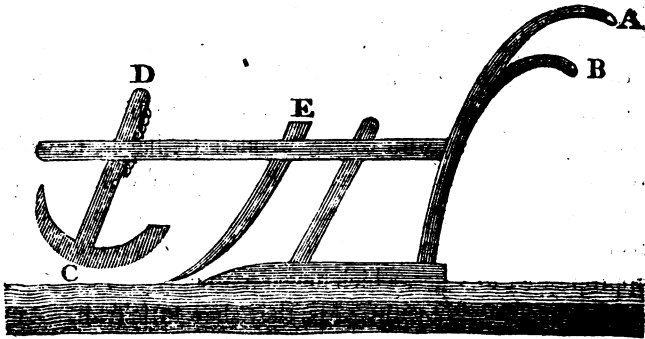

A, Single stilt.

B, Piece of bent wood, about six or seven inches long, fixed to the back of the stilt.

C D, An awkward wooden appendage, of a semicircular form, moved up and down by means of a pin adapted to holes in a piece of iron, in order to regulate the depth of the furrow: it has a broad face, which slips along the top of the ground. At this time, we found this regulator elevated no higher than to permit the furrow to be *three inches* deep, being about half the depth only of the furrow at Bruges which we have already recorded as shallow.

E, The coulter.

The head of the plough had no sock; nor was there any iron about it, beside the coulter and the kind of sub-

stitute for a rack and pinion. This is evidently a very clumsy and rude implement of husbandry; not well suited, we should think, for the expedition and activity, which we have already noticed as characterising the Flemish farmers, in preparing for their second crop.

Having reached the little village, we took shelter in the cabaret, where the clean, though homely, accommodations and refreshments pleased us much. Massive silver-forks and snow-white table-napkins indeed graced our board; but these formed a striking contrast with the awkward knives (not better than *thretty-penny joctilegs*),—with the simple fare presented, which required not the use of forks,—and with the coarse and clumsy articles of household furniture around. The thunder cloud soon passed over, and we returned homeward, again admiring, as we passed, the fine meadows and lofty trees of Oyedonck. Distant lightning continued, and became more and more vivid as the evening advanced.

Aug. 17.—To-day we attended a Protestant Church, which has been established here since the accession of the present Royal Family, chiefly for the accommodation of the troops from Holland. For this purpose the King has granted the Chapel of the Capuchins, which belonged to a monastery suppressed during the reign of Buonaparte. The service was in Dutch. The congregation was very far from being numerous; consisting, indeed, only of thirty persons, besides the clergyman. The military had attended at an earlier hour. All the pews are constructed of oak: the principal ones are marked with inscriptions, denoting that they are appropriated to the different classes of military officers. They are furnished with large quarto Bibles, bearing on the cover that they had been “presented by King William to the Protestant Church at Ghent.” Sentinels were sta-

tioned both on the outside and inside of the church, this precaution being deemed necessary for the security of Protestant worshippers; for the zeal of the Flemish priests greatly surpasses that of the French, and sometimes approaches, we understand, to the furious bigotry of the Portuguese.

Flower-Market, &c.

We remarked that the flower-market was much better supplied to-day, than it had been on former occasions when we passed through it. In the morning, indeed, some fine specimens in flower-pots appeared on the stalls, or in hand-carts called *brouettes*: these were chiefly geraniums of different kinds, carnations, tuberoses, double Indian-cress, and plants belonging to the genera *Begonia*, *Fuchsia*, *Nerium* and *Crassula*. Bouquets for sale were numerous and showy,—it being a common practice here to carry a flower to church or the promenade.

Mr Van Cassel is the principal nurseryman at Ghent; but around the city are established a number of gardeners who send plants to the flower-market, who raise fruit and forest trees for sale, and who also dispose of the fruit produced in their gardens and orchards. Among these may be mentioned, MM. Woestyn, Beque, Bauwens, Papelen, Verdonque, and Spae. In the course of our walk to-day, we entered the premisses of this last cultivator.

Spae's Garden and Nurseries.

The number of fruit-trees in full bearing we found to be very considerable. There were, however, as far as we could ascertain, no new kinds possessed of merit. The collection of rhododendrons, azaleas and kalmias, was considerable, particularly if the size of the plants be taken into account. Accidental varieties of common shrubs or trees, having the

foliage dashed with white or yellow, seem to be much in request in this part of the Continent. M. Spæ possesses the limetree, (*Tilia Europæa*), and the spindle-tree (*Euonymus Europæus*), both with leaves very prettily variegated. At the entrance to the garden is situated an uncommonly large vine, the stem, a little above the ground, measuring no less than 1 foot 9 inches in circumference. We were assured that it is more than a hundred years old, and, from its appearance, we could easily believe that it may have seen even two centuries.

M. De Wulf.

Towards evening, Mr Macdonald and I paid a visit to M. De Wulf, the keeper of the principal *pensionnat*, or boarding-school for young gentlemen, at Ghent. Among his boarders are several English youths, belonging chiefly to Roman Catholic families in the west of England. M. De Wulf employs his hours of relaxation in horticultural pursuits. He has long cultivated various kinds of fruit-trees and of American shrubs, and has not been inattentive to the raising of new or seedling varieties of both. Finding the boundaries of his original garden too limited for such experiments, he appropriated another to this purpose. His stock of fruit-trees and of shrubs still increasing, he filled a third and a fourth inclosure with them. He now, therefore, possesses four different gardens; and this gardening concern, which was at first undertaken as matter of amusement, having thus increased in magnitude and expence, he has, of late years, contrived to make it maintain itself, by disposing of a part of the superfluous produce. He told us, that his stock at present consists of at least 30,000 young fruit-trees; and he has, besides, a large collection of ornamental shrubs, chiefly American. We or-

dered, for the Society's Experimental Garden, about a dozen of apple-trees, and as many pear-trees, of such new kinds as he regarded as the best, leaving the selection to himself. He has raised many seedling peach-trees; but he said he could boast only of one of them as possessing superior merit: the fruit of this one he considers as excelling in flavour and in size, and the wood of the tree as calculated to afford a sure and ample crop. Of this desirable peach-tree he promised Mr Macdonald a plant. Among his seedling azaleas, he has procured one with striped flowers, of which he shewed us a painting made in June last, when the bush was in blossom. The species is the common *Azalea pontica*; but the flower is very curious, being coloured yellow, pink and white, in stripes or bands of unequal size: M. De Wulf therefore distinguishes it as *var. tricolor*. A London nurseryman, he told us, had offered him 850 francs, or nearly £40 Sterling, for the entire possession of this plant, and of the layers which had been formed from it. At Ghent, this appeared a very large sum to be offered for a plant; but M. De Wulf felt so much of the zeal of an amateur, that he could not deny himself the satisfaction of continuing to possess a stock of such an ornamental rarity, and he therefore declined the bargain. This curiosity we hope soon to introduce to the gardens of Edinburgh, M. De Wulf having engaged to send us a living specimen during the following season*.

After leaving this interesting old gentleman, we took a pretty extensive walk to a place called La Coupure, where

* The plant has not hitherto arrived; but M. De Wulf has written to us, mentioning that he had been much less successful than he had anticipated in propagating this new variety. The price at present is two guineas a plant.—Nov. 1819.

a pleasant promenade along the banks of a canal was frequented by numbers of well-dressed people. In returning to our hotel by the Place d'Armes, we found this extensive square filled with rope-dancers, tumblers, Merry-Andrews, and gaping crowds,—and the theatre open; forming altogether a striking contrast with the decency observed on the Sunday evening in our northern capital, where the performance even of sacred music in private parties never fails to give offence to the public, and has been known to call forth the reprehension of the civil magistrate. It ought, however, to be remarked, that the Church of Rome pays attention rather to the natural than to the artificial day, and that the sacred day is regarded as elapsed before these evening sports commence.

Beggars.

Multitudes of mendicants, male and female, young and old, assailed us wherever we went; some with a doleful “Ah! myn Heer,” others with a flippant “Pour l'amour de Bon Dieu.” We had seen a few beggars at Bruges; but at Ghent they swarm. They seem here to apportion among themselves certain walks; for the Basilisco (or Great Cannon of hammered iron, 16 feet long, placed in one of the streets) did not afford us a more certain index for distinguishing the lanes leading to our hotel, than did the well known tones of our ragged friends, who never failed to greet us with importunate salutations. Having a general recollection of the very different account given by Mr Trotter*, when he visited Ghent as the attendant of Mr Fox, during the short peace of 1802, our surprise was perhaps greater than it other-

* Memoirs of the Latter Days of Mr Fox, p. 83, &c. where, speaking of Ghent, he says, “There is here no miserable mansion, no wretched family, to distress the feelings or shock the eye,” &c.

wise would have been. We must conclude, either that the prosperity of this city has greatly declined, or that the author viewed it with a partially favourable eye.

Aug. 18.—We next day procured a voiture to take us to the village of Wetteren; about ten miles south-west from Ghent, near to which are situated the villa of M. Hopsomere, and the baronial residence of Madame Vilain Quatorze, both of which, we had been assured by our intelligent friends MM. Verbécq and De Wulf, were well deserving of a visit. By the road-side, in one place, *Pimpinella magna* appeared; and in a copse-wood, some stunted specimens of *Phyteuma spicata*.

Hopsomere's Villa.

We first came to M. Hopsomere's. The house is surrounded with a lawn, on which two fine Deciduous Cypresses display their delicate foliage. Here, as at Meulemeester's, we were much disappointed at the appearance of the head gardener, which again indicated poverty and ignorance: he did not know the names of many of the plants which he cultivates; and when we wrote some of the Linnaean titles for him, he shook his head, and signified that he could not read them. From the lawn, a gate and bridge lead to the grand shrubbery and pleasure-grounds, for, as usual, water forms the boundaries of the place. Here the first thing that arrested our attention, was a large clump of *Lilium superbum*, now in full glory. When we mention that there were at this time more than a thousand plants in flower, some idea of the brilliant effect of this bed of lilies may perhaps be imagined.

All of us feeling a predilection, as British horticulturists generally do, for evergreen American shrubs, we were very

much gratified as we advanced. The soil and situation are naturally well adapted for such plants; and it is scarcely an exaggeration to say, that, on entering these grounds, one may suppose himself suddenly transported to North America,—such is the luxuriance of the growth of *Magnolias*, *Rhododendrons*, *Kalmias*, *Ledums*, *Azaleas*, *Andromedas*, and *Vacciniums*, and such the profusion with which they are scattered over a space between two and three acres in extent. They are generally planted in clumps or compartments of various shapes, with grass lawns intervening; sometimes on little islets, or on peninsular projections; for an irregularly shaped piece of water occupies the middle of the grounds, and communicates with the exterior canal. On some occasions, different genera are grouped; on others, several species of the same genus are associated; and it often happens, that the clump is composed of numerous plants of the same species. In one place we met with a little grove of *Magnolia tripetala*, and in another with a thicket of *Rhododendron ponticum*.

We never before saw *Magnolias* in such perfection. *M. glauca* and *purpurea* were particularly large and fine. In Scotland the latter species can hardly exist in the open border; but here, one specimen measured at the base no less than three feet in circumference; almost immediately dividing into numerous shoots or branches, and forming a very fine head, the highest point of which rose, by estimation, thirty feet high. *M. acuminata* and *M. grandiflora* were both likewise in great vigour and beauty; and *M. fuscata*, which requires to be treated as a greenhouse plant with us, here stands in the open air. Two specimens of *M. tripetala*, planted near to each other, covered a space thirty-six feet in length, by perhaps half as much in breadth: Mr Hay measured the stem of each immediately above the

ground; and found the one to be 4 feet 6 inches in circumference; the other, 4 feet 3 inches.

In like manner, two plants only of *Rhododendron ponticum* covered a large space of ground. Their branches had intermingled, so that they formed, to appearance, a uniform dense clump; and on putting aside the exterior shoots, the upright stems of each plant were so numerous, that the eye could not penetrate the thicket. In the spring season, or early part of summer, this clump must have presented a continuous mass of flowers, producing a brilliancy and richness of effect almost inconceivable. The seed was now approaching to maturity; and that it very frequently ripens, was evinced by the fact, that hundreds or thousands of seedlings were every where rising in the soil beneath the bushes.

The American trees and shrubs occupy the lowest and deepest part of the inclosure. Where the ground rises gently, and the soil becomes comparatively dry, a fine group of deciduous Cypresses appears, the individual plants being of uncommon size and beauty. We measured one of the largest: at four feet from the ground, it was 5 feet in circumference; it continued nearly of the same thickness for ten feet upwards; and the branches rose, by guess, to the height of 40 feet. Here the Tulip-tree was seen in perfection; the flowers were in general past; and in some places the fruit was fully formed, rendering it probable that, in good seasons, seeds might be procured sufficiently ripe for germination, and that, in this way, a more hardy progeny might after some generations be procured.

Several plants of *Hydrangea hortensis* stood in the open border. They bore the marks of having been cut down by the frost of last winter; but they had made very strong shoots this season. They seldom produce flowers, being,

as we learned, more or less injured every winter. We remarked, that some of the more tender species of *Laurus*, particularly *L. Indica* and *L. borbonica*, had been worked on the more hardy sassafras (*L. sassafras*), and had attained the size of considerable trees. *Nyssa integrifolia*, or the mountain tupelo, seemed to grow freely here; some specimens having risen to the height of 9 or 10 feet, which is three times larger than it commonly grows in Scotland. *Clethra alnifolia* was flourishing vigorously, the numerous stems being from 6 to 8 feet high, and covered with spikes of lively white flowers. *Calycanthus floridus*, or Carolina allspice, had acquired nearly equal size, and was likewise clothed with flowers, which now diffused their aromatic scent all around. There were two varieties; one having the flowers of a dark dirty purple, the other of a pale dusky purple. *Calycanthus præcox*, or Japan allspice, of more humble growth, appeared in the borders; but it had been in flower early in the spring, being one of those plants which, like the mezereon, put forth their blossoms before the leaves.

From the description already given, it will be perceived, that the grounds are laid out in a natural and simple way, and with some degree of neatness. Plain walks wind in different directions through the grass lawns; they sometimes also traverse the dug or cultivated compartments, and cross the canals by bridges of various construction. The walks are not laid with gravel, or with any substitute for it: this circumstance must render them extremely incommodious in wet weather. We were now forcibly reminded of the value of the excellent and abundant materials for garden-walks which the gravel-pits of Blackheath had presented to us in the beginning of our journey. Where edgings are necessary, they are formed chiefly of *Erica herbacea*

and of *E. multiflora* var. *alba*: the latter was still in beauty, and formed a compact hedge of flowers; the former was now in seed, but must have been extremely brilliant in the spring months*. For the general excellence of the exotic trees and shrubs, it must be confessed that Nature does much more here than Art. The soil and situation are exceedingly propitious, and this more than compensates any deficiency in horticultural management.

The principal artificial ornament of the place consists in a rotunda with six Ionic columns. It is placed on the highest part of the grounds, so as to command a view of the whole; and also of a considerable extent of the surrounding country. Beneath the temple is a cave, having the walls formed of irregularly-shaped balls or concretions of argillaceous stony matter: these are brought from the upper part of the country, where they are found among the sand. A sinuous passage, only obscurely lighted, leads to a sombre chamber, where a female figure in bas relief is seen reclining on a tomb, in an attitude of grief. The presence of water increases the gloom: a branch from one of the canals is made to enter the cave, and a little bridge of rock-work affords the means of passing it.

From the size and appearance of many of the exotic trees and bushes, this garden of Mr Hopsomere's has evidently been longer established than any we have yet seen about Ghent; and from it, the taste for the cultivation of American plants has probably spread to the neighbourhood.

* At the new Botanic Garden of Glasgow, our common native heath, *Erica vulgaris* Lin. is employed for forming the edging to a large compartment appropriated to plants which require bog-soil. The effect is excellent; and the heath-edging is found to bear being dressed with the shears, like dwarf-box.

Seat of Madame Vilain XIV.

We now passed the Scheldt by a wooden bridge, and soon reached the fine seat of Madame Vilain Quatorze. Till we witnessed the American grounds of M. Hopsomere, our expectations concerning the state of gardening in this richest part of Flanders, had been rather disappointed, and our minds had received an unfavourable impression. Now, however, we began to alter our opinion; and the first aspect of the Place of this Lady (for it well deserves the name of a *place*) convinced us, that this day's excursion was likely to be well repaid.

Having inquired for the chief gardener, a young man of a lively and intelligent appearance soon joined us, and, on being apprized of our wishes, invited us to inspect every part of the establishment under his direction.

The mansion-house is built in the Flemish style, and is closely surrounded with a moat, so that it seems to rise from among the water. The flower-garden and pleasure-grounds are situated immediately to the westward of the house, and the kitchen-garden on the east. The most striking object in the flower-garden is a magnificent suite of glazed houses for plants, extending almost two hundred feet in length. In the centre is a green-house, nearly a hundred feet long; on each side are hot-houses, about fifty feet in length. The breadth of these houses is somewhat more than thirty feet. Flues pass along both at the back and front of the houses. As is customary in well constructed houses in Britain, the flues are every where raised a few inches above the floor*. The greenhouse is entered

* The advantages of this construction are pretty well known; but as they have not always been attended to, they may be recounted in a single sentence. Air being only a slow conductor of heat, compared with compact

from the garden by a flight of wooden steps, which are probably removed during winter, being intended only for carrying in and out the plants. The gardener's entrance is by the western extremity; and the family have access in a different way, immediately to be noticed. The height from the ground is very considerable, the floor for the plants being raised above the level of the first floor of the house, upon two rows of brick pillars and groin arches. We have now to mention, that this grand range acquired great additional interest in our eyes, when we discovered that it was calculated to communicate, directly and under cover, with the mansion-house. This communication is accomplished by means of a splendid passage or gallery. The gallery is supported by arches thrown over the piece of water which surrounds the house, and on the bosom of which a handsome pleasure-boat was at this time floating with its pendant displayed. It is lighted from the roof, is adorned with pictures, statues and casts; and between these are placed chairs and sofas of various shapes. The effect of the whole is much heightened by means of a large mirror, situated in the dwelling-house, and so placed as to embrace the whole picture-gallery, the two hot-houses, and the vast greenhouse. Other mirrors are so disposed as to multiply *ad infinitum* the surrounding objects. During the early part of the evenings of winter, we learned that numerous lamps are hung, both in the gallery and over a central walk in the plant-houses, so as to display the varied and verdant foliage at that dead season of the year. This enchantingly refreshing scene can be enjoyed night after

solid bodies, which conduct it rapidly, the intervention of a stratum of air between the bottom of the flue and the floor of the house, saves the heat from being quickly abstracted, and enables it to pass onwards, and be gradually given forth from the surface and sides of the flue.

night without injury to the plants, which remain snug in their destined winter-quarters, and are never touched by the household servants*. At this season, the greater part of the greenhouse plants were set abroad in the walks and borders; but better taste was shewn here than in some other greenhouses which we had lately visited, for a few plants were still left to adorn the house. Among those may be noticed several large oleanders (*Nerium oleander*), of the rarest varieties, with double white, and also with double purple blossoms; and *Passiflora incarnata*, which was now in flower. There was also a stage for carnations, containing several choice flowers, now in perfection. One instance of very bad taste in decoration, we must not conceal: it consists in placing among the taller greenhouse plants several gigantic human figures, about twelve feet high, formed of basket-work, and in the full dress of the court of the King of the Netherlands!

The hot-house next to the dwelling-house is provided with a tan-pit, or is fitted up as a stove, and contains a large collection of East and West India plants, in a very healthy state. The papaw-tree (*Carica papaya*) was at this time in flower †.

* When valuable greenhouse plants are exhibited in ball-rooms, or at grand entertainments, they seldom escape damage. The most magnificent specimen of Chili Pine (*Araucaria imbricata*) at Kew Gardens, was irretrievably injured by its presence at a single gala at Carlton-House, owing to the servants having very imprudently attached lamps to the branches of the tree.

† A small quantity of the juice of this plant rubbed upon butchers-meat, greatly intenerates it, without injuring its quality,—a singular property, of which the West Indian housewife has long availed herself, although the fact has been so little attended to in this country, as not even to be hinted at in Professor Martyn's edition of Miller's Dictionary. Three or four plants, of different sizes and ages, so as to be ready to succeed each other, might easily have a place in every large stove; and if beef and mutton may be made

Some pimento-trees (*Myrtus pimenta*), about twelve feet in height, pleased us much; and a large specimen of the rare cinnamon-tree of Ceylon (*Laurus cinnamomum*), which had been procured when the Dutch had settlements there, was very gratifying. *Passiflora angustifolia* of Hortus Kewensis, hung in festoons from the rafters, and was now covered with flowers. The hot-house at the farther extremity contains chiefly some of the palm tribe, and tender succulent plants. Two specimens of the sago-palm (*Cycas revoluta*) are admirable; being allowed ample space, they extend their beautiful pinnated fronds without restraint. Several plants of *Cactus grandiflorus* were very luxuriant, and had recently produced many flowers. Part of this hot-house is fitted up as an aviary, chiefly for singing-birds of warm climates, though we observed also some domesticated quails and turtle-doves. In this aviary, different sorts of common evergreen shrubs are planted, for the birds to perch upon.

The floor of the greenhouse and hot-houses being elevated about nine feet, and supported on groin arches, as already noticed, there are necessarily extensive apartments below. Here the furnaces are situated; and an enlarged idea of the grandeur of this establishment for exotic gardening may perhaps be imparted, by mentioning the simple fact, that *nine* furnaces are employed in heating the range. Owing to the same circumstance of the height of the floors, an opportunity has been found of forming a suite of small peach and grape houses in front of the large hot-houses. The peach-trees, which are trained to the back walls,

to resemble veal and lamb, and old poultry be rendered as tender as chickens, the space occupied by the papaws would certainly not be ill employed. The late Dr Holder has given an account of the intenerating effect of the papaw juice, in the 3d volume of the Wernerian Memoirs.

are too much cramped or confined. The vines are planted on the outside of the house, and the young shoots are trained upright to poles in the open air; the shoots of the preceding year being laid down and taken under the glass to produce fruit. Here, as at the seat of the Baron de Vroeylande, formerly mentioned, p. 62., the vines thus treated are sickly and weak. Still in front of these peach-houses or vineries, is a row of melon and cucumber frames. The combined effect of the whole is rather surprising than pleasing: we see, as it were, a sloping hill of glass; we wonder at the disregard of expence, and are forcibly reminded, that in the Netherlands there is no duty on that article of manufacture.

In the greenhouse an album is kept, in which visitants are requested to enter their names, and we accordingly inscribed ours. Madame Vilain Quatorze herself soon afterwards entered. Having inspected the book, she signified her approbation of our visit, and courtesied to us as we passed. This lady is advanced in years; but still enjoys, with great relish, the beauties of vegetable nature. She superintends with zeal the cultivation of her extensive stores of exotic plants, and shews all the keenness of youth in adding any thing new or curious to her ample collection. She has been peculiarly fortunate in a head-gardener. We found Pierre Gothard (for such was his name) quite a contrast to those whom we had hitherto met in this country. He was well informed and curious; anxious to communicate information, and equally ready to learn from us. The healthy state of the greenhouse and hot-house plants, and the general neatness of the place, shewed that he understood his business as a gardener; and it was pleasing to hear him modestly ascribe the praise to his liberal mistress.

While Mr Macdonald and I were inspecting the plants, and conversing with Pierre, Mr Hay occupied himself in drawing a plan of the suite of hot-houses, and a section of one part, ascertaining the distances partly by pacing and partly by actual measurement. At the same time, he took an eye-sketch of the grounds immediately around the house. The annexed engravings of these, will convey a much more distinct idea of the place, than could be communicated by any description.

Plate II.

Ground-Plan of the Suite of Hot-Houses, and Eye-Sketch of part of the Pleasure-Grounds at Wetteren, by Mr Hay.

- A, Hot-house for exotic plants.
- B, Aviary, with shrubs for the birds to perch upon.
- C, Gardener's room.
- D, Greenhouse. *d*, Entrance by flight of wooden steps.
- E, Stove for exotic plants.
- F, Dry stove.
- G, Picture gallery, of a considerable height. It has an arched roof, and is lighted from the top.
- H, Dwelling-house.
- I, A large mirror is placed at the end of this passage. Lamps are suspended from the ceilings of the house, gallery, greenhouse and stoves, at the places marked thus +. When lighted, the whole line, from the one extremity to the other, must be reflected by the mirror.
- K K, Grape and peach houses. Peach-trees are planted at the back wall of each, and vines at the front.
- L L L L, Pits for greenhouse and stove plants.
- M M, Pits for melons, cucumbers, and other tender plants.
- N, Large barn.

P I
of
HOT-
at the
MADAME
With an Eye
GRO
By Jo

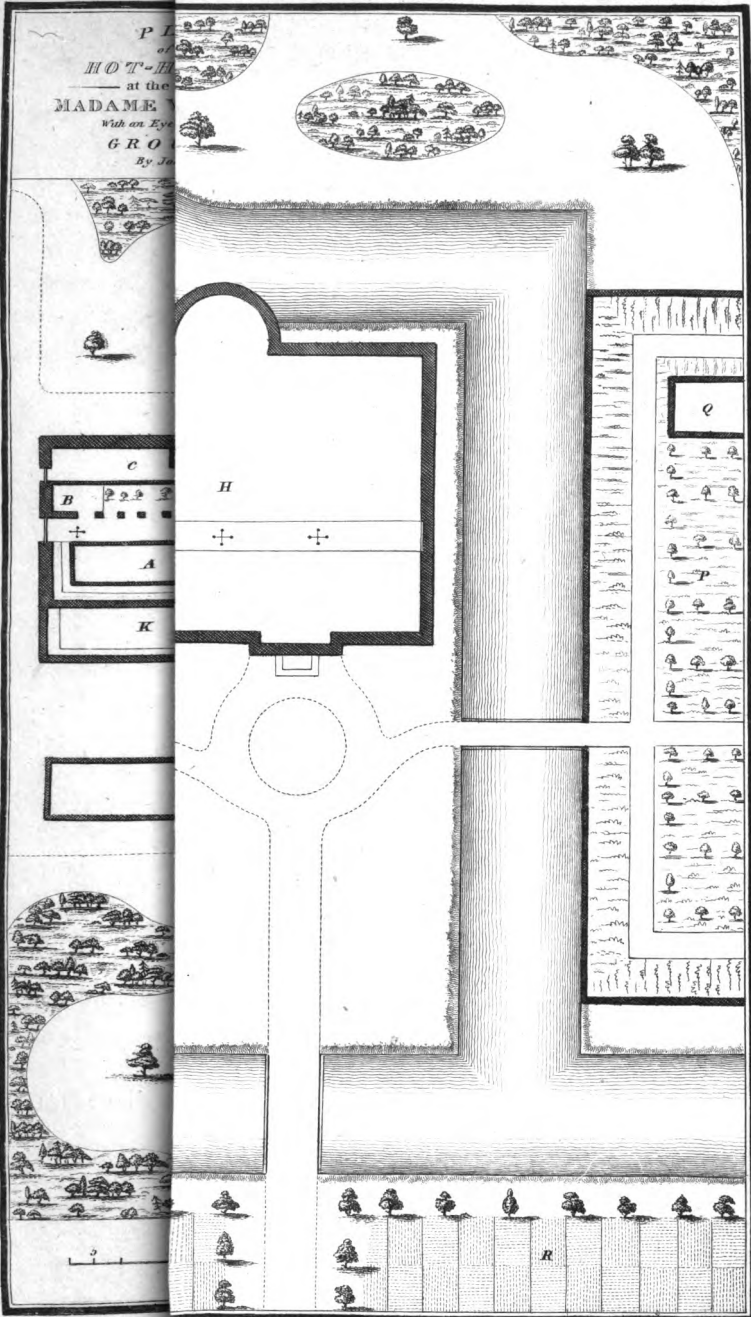

Drawn by John Day.

Eng^d by W. R. Laidie



SECTION OF THE GREAT HOT-HOUSE AT THE SEAT OF MADAME VILAIN QUATORZE.

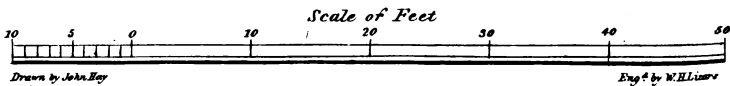
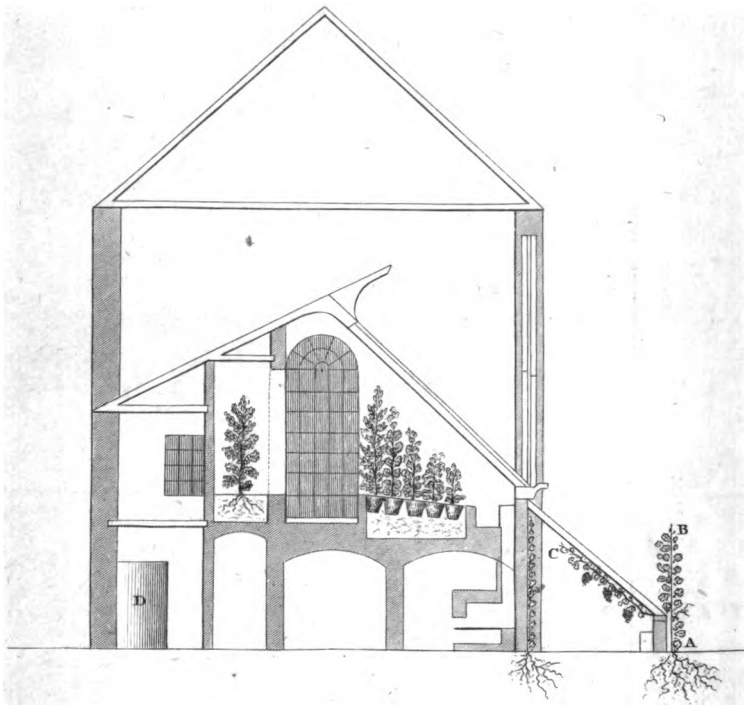

Drawn by John Eay

Eng^d by W. H. Lister

O, Stables and cow-houses.

P, Part of the kitchen-garden.

Q, Part of the pine-apple stoves.

R, Corn fields, under crops of Indian corn, wheat, hemp, &c.

The principal floor of the house and the picture-gallery are upon the same level. But there is a rise of a few steps to the floors of the stove and greenhouse, which are elevated above the ground more than nine feet. The grape and peach houses K K, with the pits L L L L, and M M, are on the ground level.

Plate III.

Section of the West End of the Hot-Houses, at A of Plate II.

A B, Vines planted on the outside of the house, and the shoots trained to trellises or poles during the summer.

A C, The young wood of the preceding year taken into the house to produce fruit.

D, Door by which the gardener has access to the hot-houses.

N. B. The plan and section were taken in a hurried manner; the greater part by pacing, the remainder by actual measurement; the house, gallery and grounds, by the eye.

The grounds are so varied and extensive, that to describe them in detail would be impossible. Water forms one of the principal ornaments; but too much use has probably been made of it. It is conducted by flexuous canals in almost every direction, and is here and there allowed to expand into little lakes. It was justly observed by Mr Hay, that had the sweeps of the canals been fewer and more gentle, and all sudden turning and twisting avoided, the effect would have been greatly superior.

Among the ornamental structures may be mentioned a kind of triple bridge, and a lofty pagoda. The bridge passes over the canal, at a place where it diverges into three branches: some idea may be formed of the structure, by conceiving the three arches to spring from the three angles of an equilateral triangle, and all to meet in the centre. At this central point, several neat columns support a slight dome over a circular space, and form it into a kind of temple. The sketch in Plate IV., although partly done from memory, will convey a more distinct idea than the most laboured description.

Plate IV.

A B C, Plan of the bridge.

D, A circular seat around the middle column.

The chateau is situated in the direction of the letter E.

To the north of the house, the canal expands to a considerable extent, and forms a fine sheet of water; and the bridge is seen in an angular direction from the northern windows of the chateau.

The pagoda is situated close by this bridge, and is an elegant building. It surmounts the ice-house; and thus converts into an ornament, what, in this flat country, it might have been difficult to have disguised, or prevented from appearing as an ugly bump.

The offices, consisting of a large barn, with stables and cow-houses, are placed in front of the principal windows of the house (N and O in the plan), and only at a very short distance from it. To our eyes they appeared much out of place, and far from ornamental,—detracting considerably from the character of the lawn, otherwise sufficiently circumscribed. The motive for placing them here, seems

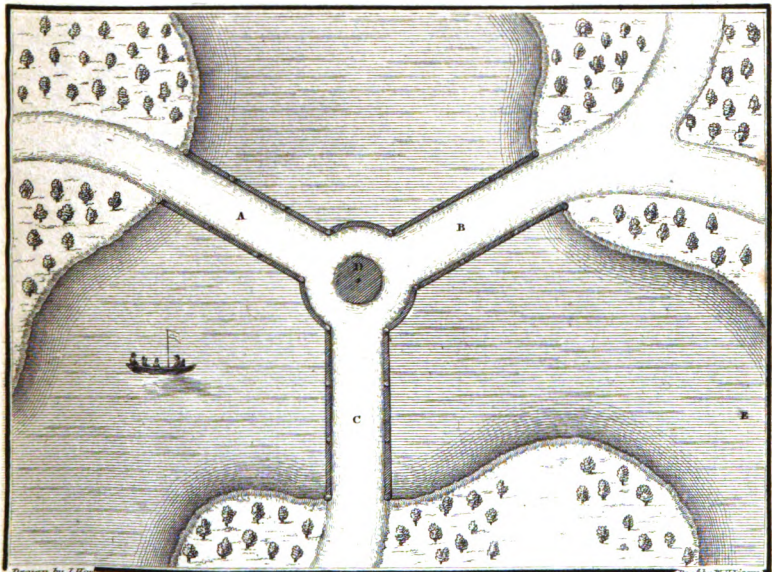
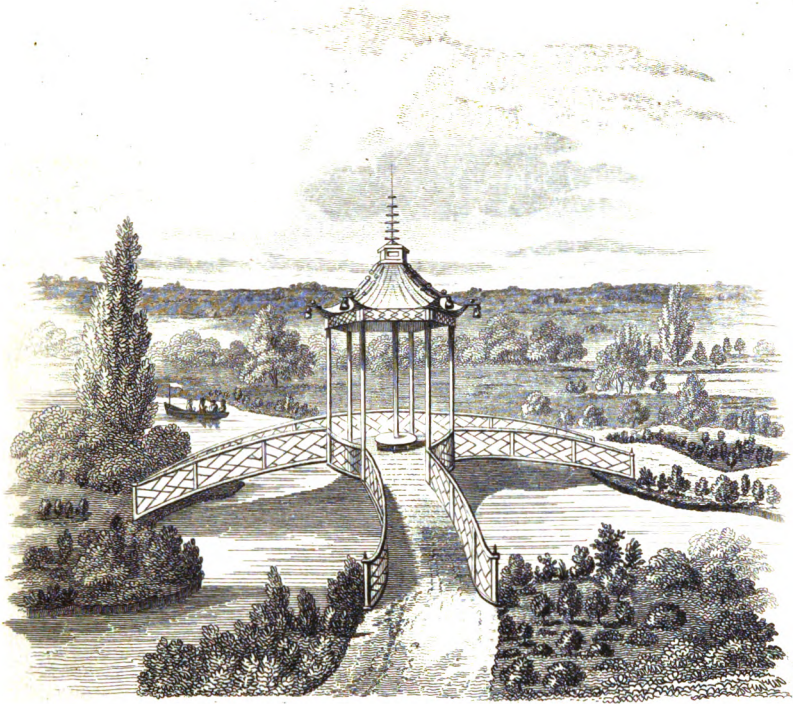

Drawn by J. Hay

Eng'd by W. H. Lister



to have been the security against depredations or sudden attacks, afforded by the surrounding moat.

In proceeding to the extremity of the grounds, we came to a small neat cottage; from the little windows of which, one looks out upon the *real* country,—with smiling hamlets in view,—peasants engaged in the labours of the field,—and cows grazing in extensive meadows; a broad canal, in some places with a single row of large trees, forming, as usual, the only boundary of the place, instead of a wall, or a hedge, or a stripe of planting, as in England.

A splendid Palladian bridge, having the roof supported by marble columns, and with stone sphinxes at each end, conducted us, on our return, toward a summer-house, the windows of which have the panes stained of different colours,—the yellow glass, in particular, producing a very rich and warm effect, from being now touched by the slanting rays of the declining sun, scattered and partly intercepted by the neighbouring trees. In a lawn not far from the house, stands a circular aviary, formed of wire. It is about twenty feet high, and perhaps fifteen feet in breadth. In the centre is an upright pole, with cross perches for the birds. The only inhabitants, at this time, were some turtle-doves.

The vegetable ornaments of the extensive garden-grounds are in general of the most select kinds. The shrubs are disposed in clumps, of various sizes. The American plants are fine, being surpassed only by those at the villa of M. Hopsomere, formerly described. *Ceanothus Americanus*, or New Jersey Tea-tree, which, in the best districts of England, reaches only three or four feet in height, was here fully ten feet high. *Cephalanthus occidentalis*, or American button-wood, had attained nearly the same size. Among the larger trees, a fine specimen of the weeping

birch (*Betula alba*, var. β) had a very picturesque effect. A compartment is devoted exclusively to the more hardy oriental plants, either shrubby or herbaceous; and here many natives of the Levant, of Hungary, Tartary, and Japan, are collected together. Even the Nicker-tree, or *Guilandina bonduc*, seems here to be acclimated. A very long border is appropriated to all sorts of variegated trees, shrubs and herbaceous plants; and the assemblage of these surpassed, both in number and variety, any collection of the kind which we had ever seen. From remarking the vigour of many of the plants in which the foliage was strongly variegated, we could not help dissenting from those physiologists, who have ascribed all sorts of variegation merely to debility; and felt inclined to agree with Mr Knight, that there must be two kinds of variegation, one connected with disease, and the other quite consistent with the healthy state of the plant.

In the flower-borders immediately in front of the hot-houses, were some very showy annual plants; such as the *Ricinus communis* or castor-oil plant, in full flower, and two species of *Zinnia*, *Z. multiflora* and *elegans*, the latter extremely beautiful and rather uncommon. Numbers of these had been raised on a hot-bed, and afterwards planted out: they were here much more luxuriant than they usually appear in our gardens. The genus *Dahlia* was likewise very ornamental, particularly some double flowered varieties, both pale and dark purple.

On the east side of the mansion-house is the kitchen-garden which is of very considerable extent. On three sides it is protected by brick walls, against which are trained peach and nectarine trees, and some vines. On the side next the house, the only defence is the broad canal already mentioned. There is in this garden a pine-apple stove, of small

dimensions;—but this we could not wait to examine: evening was fast approaching, and we had to return many miles to Ghent, by a road little frequented, in most places buried among trees, and altogether not the fittest for nocturnal travelling.

The farm is situated in front of the chateau, immediately on the outside of the moat. Some of the crops were to our eyes of an unusual character; and the novelty of their appearance, perhaps, not only concealed the deformity of placing a farm there, but converted it into something rather agreeable. We were certainly gratified at seeing a large field of hemp (*Cannabis sativa*), now in full luxuriance, for this is a crop seldom or never attempted in Scotland,—and absolutely delighted to meet with a small field of Indian corn (*Zea mays*), now shooting into ear; for none of us had ever seen a crop of this nature. Probably this may be regarded as nearly the extreme northern limits of the zone within which maize may be cultivated.

Our apprehensions as to the impropriety of allowing ourselves to be benighted on the road, proved not ill-founded; for we met with some trouble from two fellows, who had dogged us from Ghent in the morning, and who now returned in our train, having regaled themselves liberally at the cabaret with our postillion, doubtless at our expense. They spoke French, and boasted that they had served in the army of the Emperor. Although they tried in various ways to irritate us, as they did not presume to offer any actual violence (for repelling which, however, we judged it prudent to hold ourselves constantly in readiness), it is possible that they may have been police-spies of the government. We had hoped that this sort of espionage had ceased in the Netherlands upon the accession of the present king.

The very limited portion of time which we are able to dedicate to our tour, obliges us here to take leave of Ghent. We do so with some feelings of regret; having seen enough to convince us, that longer residence, and more patient investigation, might afford both to the gardener and the husbandman much useful information.

Miscellaneous Observations.—Markets; Succory, &c. &c.

We have, during our stay, daily visited the green-market. Next to the fine cauliflower already mentioned, the best culinary production seems to be Carrots, which are uniformly clean and healthy, and remarkably juicy, surpassing in quality those which we saw at Bruges. The orange-coloured variety is not uncommon; but the red carrot, with us styled field-carrot, seems to be more generally cultivated. M. De Cock mentioned, that it is customary to sow some of the seed of these red carrots on hot-beds about New Year's day, and thus to have young roots for use in February and March. A full crop is sown in the gardens in March and April, and during the rest of the year fine carrots appear plentifully on the stalls. The excellence may in a great measure depend on the favourable nature of the soil; but it might be worth while to procure some of the Ghent carrot-seed. M. De Cock also mentioned a kind of Early Pea, the seeds of which ripen in July; and added, that the new peas, sown in that month, yield a crop in September of the same year,—vegetation going on very rapidly at that warm season, and this variety running very quickly into flower and pod.—The Early Potatoes here are inferior to those of the Edinburgh market. Kitchen vegetables are in general cheap in Ghent; but the unfavourable season has raised the prices. Pease, beans, and other pulse, are sold by the French mea-

tures: the hectolitre, which is nearly equal to three English bushels, costs at present from 15 to 18 florins (from 25s. to 30s. English). This is considered as very dear at Ghent.

In the neighbourhood of this city, *Succory* is cultivated in still greater quantity than near Bruges. Our intelligent acquaintances here, confirm the account which we formerly received of the various uses to which the crop is applied. The large roots are cleaned, and cut into small pieces of nearly equal sizes. These are carefully dried in an oven, so as to retain their plumpness, or avoid shrivelling. As needed, they are reduced to a powder by grinding. The infusion of this powder is used by the lower orders as a breakfast beverage; but all the better sort of the common people employ it mixed with a certain proportion of West India coffee. Many profess to give to the mixture the preference over pure coffee; it being thought that the succory communicates to the infusion the power of acting as a gentle diuretic. The leaves, and such roots as are too small for being prepared as coffee, are given to cattle, especially to milch cows, which are here kept in the house in great numbers. Succory is likewise employed as a winter salad. For this purpose, a number of plants being raised with balls of earth at the approach of winter, are heaped around with sand, in some cellar or close out-house, from which frost and light are equally excluded. Here the plants continue to vegetate; and the leaves produced being tender and blanched, are much relished as a salad from December to February. From the whiteness produced by blanching, this salad has got the name of *Barbe de Capucin*.

M. Verbecq spoke of the "new sort of Colza introduced at Ghent by Sir John Sinclair." This, we found, was the *Ruta bāga* or Swedish turnip, till then (1815) unknown in Flanders. It was found more hardy than the cole, and

the seeds are said to afford, by crushing, oil in as great quantity, and of equal quality.

The market for butchers-meat here, is kept extremely neat and clean; no offensive streams of blood are to be seen, every thing of that sort being confined to the shambles*. Each dealer in meat keeps a carpenter's plane, with which he daily shaves the surface of the table of his stall; so that a stranger entering the market in the morning, would be apt to think that all the tables were new. The meat offered for sale is divided into such small pieces, that an English housewife would search the market in vain for what she would deem a respectable roast. There is a degree of delicacy even, in this practice of minute division; the fragments presented at table never recalling the idea of the part of the animal to which they belong.

The *foreign* appearances have increased at Ghent.—The *small mirrors*, which we observed placed angularly at the sides of some windows in Bruges, are very general here. Persons sitting near the windows thus see all that passes in the street, or ascertain the visitant who knocks at the door, without looking out.—*Archery* is the favourite amusement of the men. Several imitations of birds are placed at the top of a very long pole, placed upright, and the marksmen endeavour to dislodge these birds with their arrows. Such popinjay poles are to be seen both at Ostend and Bruges; but they are here more common.—In place of carts, the quays of the canals are

* In the Edinburgh poultry-market the gutter is often seen running with blood, warm from the arteries of some unhappy pig, whose quivering screams at the same time assail the ear. Even the agonized writhings of turkeys and ducks ought not to be witnessed in a public market. As soon as space can be procured, we doubt not that this evil will be remedied by the public-spirited rulers of our northern capital.

crowded with long narrow waggons, having lofty ornamented backs, like sterns of ships. Very exact representations of such waggons may often be seen in the *payages* of the Dutch masters; the form of them having probably undergone no change for centuries past.—In Ghent, the preparations for shoeing a horse are so formidable, or the animal is secured with such precaution in a strong wooden frame or case, that, at first, we could not help thinking that the farrier was about to let blood or draw a tooth, and were rather surprised to find that only a shoe was to be fastened.—The manufacture of lace has, we understand, vanished from this place, and been replaced by that of cotton; no-wise, it is believed, to the advantage of the morals of the young females employed, who are thus brought together in great numbers, instead of working, as formerly, in the houses of their parents.—There is a large iron manufactory in the immediate neighbourhood of the city, the most considerable, we understand, in this part of Flanders.

De Bussche and Son are the booksellers or publishers in whose shop any agricultural, statistical, or horticultural work, regarding the Low Countries, is most likely to be met with.—We could not fail to remark the dearth of newspapers. The common people seem never to think of such things. What a contrast with Edinburgh, Glasgow, or London! If the extensive circulation of newspapers sometimes promote the aptitude to political ferment, we must not forget, that much of the superiority of the great body of the people in Britain is to be ascribed to “these rivulets of intelligence,” as Dr Johnson beautifully styles them, “which are continually trickling among us, which any one may catch, and of which every one partakes.”

From Ghent to Antwerp.

Aug. 19.—We left Ghent about 5 A. M. for Antwerp. Even at this early hour, the lower orders were hurrying to matins; and though it was scarcely day-light, a posse of beggars did not fail to attend us, and to proffer, at very easy rates, the benefit of their prayers for the prosperity of our journey.

The country through which we passed this morning was extremely well cultivated. The soil is naturally light, or even sandy; but agricultural industry has rendered it fertile. The surface continued quite level. The centre of the high road, to the breadth of about fifteen feet, is paved with stones brought chiefly from Fontaine l'Evêque near Charleroi. This forms the *chaussée* properly so called; it is occupied by waggons and by *diligences*, which in this country resemble waggons. Spaces of equal breadth with the *chaussée*, and often much broader, are left on each side, laid only with sand: these are used by equestrians, and frequently by persons travelling in cabriolets. In general, there are rows of trees on the exterior margins, chiefly elm and ash; and frequently there are ditches full of water, beyond these. Coppices of oak and alder abound. Small orchards, containing apple, pear, plum, and cherry trees, are not uncommon; and on the whole, the country is well wooded.

Having, after travelling for between three and four hours, thought it time to inquire about breakfast, our *conducteur* assured us that he was not in the practice of making a halt for such a meal, but added, that we might snatch a cup of coffee while our horses were changing. This we effected at a little village called Sinay, not far from the numerous small canals of Moerbeke. We now entered

the Country of Waes, accounted one of the richest in Flanders, and reminding us of the finest parts of East Lothian. The road was skirted with hawthorn hedges; in some places intermixed with sweet-briar, in others with common dogwood and purging-buckthorn. Before mid-day we reached the ferry station called Flanders Head (*Tête de Flandres*), from which we had only to cross the Scheldt to Antwerp, being a passage of somewhat more than a quarter of a mile. Near to this, we saw some of the sluices and dikes, by opening which the country, on this side of the river, was inundated to a great extent in 1814, when Antwerp held out for Buonaparte till after the Allies were in Paris. At Flanders Head, we were told, the Emperor intended to have erected a considerable town; and it is evident, that, by means of the water of the Scheldt, the place could at any time be completely insulated, and rendered inaccessible to an enemy. Having entered Antwerp, we took up our abode in the *auberge* St Antoine, in the Place Verte. The great fair or *kermis* had just closed; but many of the temporary booths still remained in the large square fronting the Exchange.

ANTWERP.

We spent the afternoon in taking a general view of this celebrated city and port. All the principal houses are built of sandstone (commonly called *kareelsteen*, but not granite), brought from Boom; a village situated about three hours walk, or ten miles, from Antwerp.

Our attention was soon attracted by the Cathedral. It is a noble edifice; but we were not a little scandalised to find its walls disfigured by having paltry shops adjoined to

them, like those lately swept from the base of St. Giles's at Edinburgh. On entering, we were delighted with the effect of those inimitable ornaments, the folding paintings of Rubens, at the high altar. These, it is well known, were prepared by the artist expressly for the situation which they now once more occupy (having been last year sent back from Paris), and certainly in no other could they be nearly so effective. We ascended the lofty steeple, which is constructed of stone, and about 400 feet high. The day being clear, we enjoyed a very extensive prospect. By means of a small telescope, we were able to see objects pretty plainly for about forty miles on every side. We could distinctly trace the whole road by which we had, in the morning, travelled from Ghent. Towards the south, Malines appeared very distinct; and by employing this city as a point of direction, our guide enabled us to make out both Brussels and Louvain in the distance. All this extent of country appeared like one vast flat forest, and the high roads like white lines traced among the trees. Towards the east, our view was bounded only by the sea: beyond Fort Lillo, we could descry the shipping at Flushing, and the steeple of Middleburg. To the northward, the country seemed comparatively bare and poor.

All the large trees immediately around Antwerp had been felled by orders of Carnot in 1814, as preparatory to the determined defence of the place which he contemplated. The line of this precautionary devastation was still easily traced by the eye, although great numbers of young trees had been planted in the room of the old ones.

We visited the new quay and basin begun by Buonaparte, and on which, it is said, he prided himself much. They are doubtless grand works; but to those who have seen the docks at Liverpool, or at the Isle of Dogs below

London, they lose much of their importance. As horticulturists, we will be excused for remarking, that the inhabitants of this part of the Continent undoubtedly excel us in attention to arboreous decoration. Along the whole stretch of the new quay, a row of elms has been lately planted. Although the plants are comparatively young, they are very tall; and the stem of each tree is surrounded and secured from injury by a neat square box, about four feet high. The expence must, therefore, have been very considerable. The effect of this line of elms will, in the course of a few years, be beautiful. It may here be noticed, that in the Low Countries, different kinds of forest-trees, particularly elm and ash, are trained in a particular way in the nurseries, with the view of being planted on the sides of streets, or by the edge of the highways: they are regularly pruned up like high-standard fruit-trees, till, after perhaps eight or ten years, they acquire a stem from ten to fifteen feet high. Having, during this period, been several times transplanted, their roots form dense tufts of small fibres; a circumstance which greatly facilitates the removal of such lofty plants, and the speedy renewal of their growth in their ultimate situation. Out of several hundreds lately planted along the quay of Antwerp, only two or three had failed to grow.

Green-Market.

Aug. 20.—The market for kitchen vegetables is held early in the morning, in one of the principal streets, extending from Place de Mere to Place Verte. The display this morning was great; the street being lined on both sides with stalls, with brouettes, wheel-barrows and hampers, for at least three quarters of a mile. All the smaller articles were neatly packed in little wicker-baskets; the

larger ones in hampers. They are, in general, sold by the country people immediately to the inhabitants, without the intervention of green-grocers or retailers. In quality, they seem, upon the whole, inferior to those of the market of Ghent. Potatoes should, however, be excepted: they are perhaps better; and we here noticed, for the first time, a small red kidney potato of very promising appearance. We procured a few tubers for the intended Experimental Garden. In the fields around Antwerp, we remarked potato blossoms of an uncommonly rich blue colour: these, we were told, however, belonged to a *geele aardappel* or yellow potato, not to the red kidney. Parsnips were abundant, perfectly clean and smooth, and already (20th Aug.) of large size. The same thing may be said of horn carrots. The late white Scots cabbage here first presented itself to our notice on the Continent, and in tolerable plenty; but the Savoy cabbage was much more abundant. The long-shaped variety of black Spanish radish, with roots not unlike parsnips, seems to be the only kind of radish here cultivated: it was very plentiful, while we did not see a single specimen of the round or turnip-rooted variety. In general, these Spanish radishes were very large, exceeding in size any carrots or parsnips brought to market.

On making inquiry about gardens near Antwerp, we learned that the first in every respect was that of Mr J. G. Smetz, the principal banker. We waited on this gentleman at his banking-office, and were invited to see his garden in the country on the following day. Although Antwerp was once distinguished for its gardens, we could not now hear of another worth visiting, its botanists and florists having completely passed away. We therefore hired a *commissioner*

(for so the *cicerone* is called in the Netherlands), and made him conduct us to the various places and objects usually visited by travellers. Some of these may just be mentioned. The ancient Bourse is considered as having afforded the model of the Exchange at London; but it excels the latter, in its rows of marble columns, with capitals curiously varied. The vast magazine near the quay, called the Hans Towns House, is now in partial decay: it had received some hard blows during the bombardment of 1815,—other bad effects of which, our guide (a keen Buonapartist) did not fail to point out to us. More effectually to cover the great basin, new works of defence are now rearing, under the direction of the engineers of the King of the Netherlands. In walking up the side of the river, we came to the flying-bridge of Buonaparte, which is now in disuse, but was lying moored to the beach. This huge ponton is of such dimensions, that it could transport a whole regiment at once. To facilitate the entrance and exit of cavalry, wooden piers were constructed on both shores, with the outer part of the pier floating, or moving on hinges, so as to rise and fall with the tide. The ponton was put in motion by the current of the water against a large rudder, by setting which it could be impelled to either bank, swinging as it were upon a long cable, which was secured by anchors in the middle of the river. On account of the length of the cable, two or three small boats were necessary to support it. Similar passage-boats occur on the Rhine: there, however, the stream flows constantly in one direction; while here it was requisite to have two points of resistance, one up the river and the other below, on account of the water running upward with the flow of the tide, and downward with the ebb. We next visited the great naval arsenal, and the extensive *Corderie* or rope-walk, for the

manufacture of all kinds of ship-cordage, both established by the same wonderful man. The cloisters of the suppressed Abbey of St Michael, one of the most opulent religious establishments of the Low Countries, were now used for the stowing of naval timber.

We entered the citadel, having readily, as English strangers, obtained the permission of the commanding officer. We walked on the top of the ramparts, so as to command a view of the whole at once. The citadel is of a pentagonal shape; and the walls and fossés appeared to us much more formidable than those of Ostend. That it might be defended against a very powerful assailing army, is abundantly evident. In the last struggles of Buonaparte, it became a place of signal importance. Here, as already noticed, he thought it worth while to station the celebrated mathematician and engineer Carnot in 1814; and in the following eventful year, the Duke of Wellington fixed on this as the point to which he would retreat, in case he should have been unable to protect Brussels: he therefore threw into it a garrison of British soldiers; and had the day of Waterloo turned against him, there can be no doubt that he would have held out this citadel till relieved by the advance of the Russians. We procured access to the *Galerres*, or great prison for felons, which is situated within the citadel. About 1000 offenders were now in confinement, none of them for less than five years, many for ten years, and not a few for life. They are kept closely at work; but all the employments which we saw, were of a sedentary kind. Some of the apartments were very ill ventilated, and had a nauseous smell. The jailor, indeed, who accompanied us, alleged, that, on an average, not more than twenty die in the year; the greater number of the inmates, however, appeared squalid, pale, and emaciated. We were

sorry to learn, that young lads convicted merely of desertion from the army, were mingled with the more atrocious offenders. In general they were secured with iron fetters; and we were glad to escape from the disagreeable sound of the clanking of chains.

That the town in which Vandyke, Rubens, Masseys, and the Teniers, once flourished, should still be distinguished for paintings, we naturally expected. There are, in fact, several large collections, to all of which our countrymen find easy access. Indeed, where the pictures are for sale, the visits of the English are eagerly courted. We were satisfied with a view of the sale-collection of M. Beeckman, a merchant in the Place de Mere. M. Poorten of this city, we may remark, has of late years acquired a high reputation for painting animals.

M. Smetz's Place.

Aug. 21.—This morning we procured a voiture to conduct us to the country seat of M. Smetz, in the parish of Deúrne. This obliging gentleman, we found, had waited at home to receive us; and before he set off for the city, he called his gardener, Mr André van Donkelaar, and gave him directions to shew us every thing about the grounds.

There is here a union of the Dutch and the English style of gardening, the place having been originally laid out in 1752, and having subsequently undergone many alterations and received many improvements. Close by the house, the eye is distressed, at one moment, with the most precisely clipped hedges of tree box, four feet and a half high, tortured into the resemblance of modern beehives, and of antique vases; and it is relieved the next, by a fine sheet of water, over which a bridge is thrown. This sort of conflict is felt throughout: but, as a whole, the place is delightful; for the grounds are made to unite

very naturally and gracefully with the surrounding country,—which indeed may be said to be a continued garden. The vista view from the house is so contrived, that it stretches imperceptibly into the natural wood in the distance. The house, like most of the others which we have visited in the Netherlands, is moated, or immediately surrounded with water. This, we should imagine, must be prejudicial not only to health, but to comfort. Here the water is very near the surface; and so low and flat is the situation, that the pond which surrounds the house does not seem to require feeders.

We are well aware how tedious and how unsatisfactory detailed descriptions of scenery generally prove. Even the accounts of Hagley, by Heeley, Maurice, and Wheatley, soon satiate the reader; and if the classical seat of Lord Lyttelton do not possess sufficient interest, what may be expected from minute details regarding the level green lawns and still waters of a Belgian demesne? Although, therefore, we shall notice only a few of the most prominent features, in the order in which they occurred to our observation, we must bespeak the indulgence of the reader.

Soon after leaving the house, we came to a circular pond, around which, on a double row of raised terraces, numerous orange-trees are placed at this season of the year. The collection of these is great, there being not fewer than 150 plants, large and small. Some of the specimens are excellent, and have not been so unmercifully clipped as those at the Ghent Garden. Several inches of the surface-soil of the boxes in which the orange-trees are planted, consisted almost wholly of *hen-pen*, and this acrid manure was nearly in a recent state.

Observing a pagoda rearing its head above the trees, we walked towards it. With the exception of the pa-

goda at Kew, this proved the finest structure of the kind which any of us had seen. In the lower apartment are four niches, which we found to be concealed doors; one leading to the staircase, and the others to presses, where books, tea-equipage, &c. may be kept. On the ceiling, over the arches of the stair-case, a group of celestials is represented, looking down on us mortals below. As the light which falls on the painting above is powerful, and as the spectator sees it as it were through a tube, the effect is very striking. As we ascended, we paused at various successive balconies, the prospect of course increasing in extent as we gained height. From the summit we had a view of the country for about twenty miles in every direction. Antwerp was distinct, and in a clear day the spires of Malines are seen. A large reservoir at the top is said to be capable of containing 100 tons of water: this feeds various fountains below, some of which are, as usual, contrived to give the inquisitive a wetting. The ornaments of the highest part are fantastical: the whole is surmounted by four large brazen, or at least gilded, serpents, intertwined; and the apex is formed by a fruit of the ananas. The extreme height is 120 French feet, or somewhat more than 100 English.

The water in the neighbourhood of this Chinese temple is truly ornamental, forming a natural sweep, and being occasionally overhung by weeping-willows scattered along the margin. In some places the banks are open, and a receding lawn presents itself, chequered only by a detached cedar of Lebanon, or a tulip-tree. In one place is a Chinese bridge, of considerable span, harmonizing excellently with the pagoda, and producing a gay and airy appearance, finely contrasted with the dark shadow cast upon the water, which, though pure, seemed motionless, unless where disturbed by the slow approach of the stately swan,

or the more rapid movement of the Canadian goose. A small junk at anchor was likewise completely in character. In another place is a bridge, built in imitation of an ancient ruin. The materials are, from their appearance, very suitable for such a work, being irregular stony masses, resembling large nodules of flint, brought from the neighbourhood of Schaerbeek, a village near Brussels. Below the abutment of the bridge is the entrance to a grotto, or rather to a cryptum, or cool cavernous walk of some extent; the arches and walls of which are formed of the same materials. Various species of *Cyprinus*, particularly carp, tench, bleak and roach, abound in the smaller canals; and perch and jacks (or young pike) in the larger pieces of water.

One of the ornaments of the place, if it did not please us, at least gave us a surprise, being rather of a singular cast. Emerging from a shady walk, which had led us through wildernesses and groves, we came suddenly upon a grassy lawn, which seemed to be occupied by a small flock of sheep, some pasturing, and some reposing; but although we continued to advance, all remained motionless,—for the sheep were carved in stone! The figures are more than thirty in number; they are represented in every sort of attitude; and, upon the whole, are not discreditable to the artist. In his anxiety, however, to render the scene perfect, he has overdone it, by adding a shepherd and two dogs: these attendants are here out of place, and the deception would be improved if they were removed. The same remark may be applied to a group in a neighbouring lawn, of a wolf attacking a bull; with the addition, that in this last the figures have less merit as pieces of sculpture. A parcel of dwarfish human beings in an opposite recess, is in still worse taste; and a drunken fellow is represented in a situation which can only excite dis-

gust. We have still no praise to bestow on the device which next succeeds,—a fancy tomb, with grated doors and windows, and the inscription *Vanitas vanitatum*: nor could we perceive either beauty or wit in an adjoining cave being insidiously beset with fountains, and quaintly inscribed “ XI. Præceptum.” The eleventh commandment, the gardener exultingly told us, was “ Gardez-vous;” an injunction which was at this time quite superfluous, the pipes and stop-cocks being all out of order; a state in which we have found every threatening fountain which we have hitherto seen on the Continent. In this portentous cave, the Grecian Cynic is represented in his tub; and in an adjoining hermitage, covered with the bark of trees, and verging to decay, an anchorite is seen poring over his missal. To close the list of these miserable extravagancies, we shall notice only a chair or seat, which was also pointed out to us by our guide with no little self-complacency; it is so contrived, that the unwary visitant who takes possession of it soon finds himself seated among water!

We turn to a more pleasing subject, the glazed houses for plants, which are here on an extensive scale. M. Smetz had sent his gardener both to Paris and London, to observe the modes of gardening, and particularly the construction of hot-houses, at the many fine country-seats near those capitals; and Mr Donkelaar had certainly not been inattentive to what he saw. There is an old greenhouse, more than a hundred English feet in length: on this the gardener had made some improvements; but the construction is radically defective. It did not now contain plants, but was, as usual in this part of the world, plentifully stored with lumber,—the gardener having omitted to learn the lesson of neatness, which the practice of his English brethren might have taught him, in

regard to the summer decoration of the greenhouse. The stoves are what are called double houses; that is, they consist of glazed frame-work on both sides, and have a span roof. They are situated at each end of the large greenhouse, and project at right angles from it. They are quite new, having been built from designs prepared by Mr Donkelaar, on his return from his travels. They are very high in the front or upright glass, not less than sixteen feet; while the rafters, both upright and sloping, are very thick, and the glazed sashes between them not more than three feet wide. This has a bad effect. Mr Hay remarked, that the houses are not sufficiently wide in proportion to their height: and the tan-pit in the middle, and the surrounding foot-path, are much too narrow. Both the hot-houses and the greenhouse are provided with wooden shutters, which constantly remain attached to the rafters, but in a folded state. Even in this state, they project about ten inches, and must have the effect of excluding the oblique rays of the sun, while at the same time they give the houses rather a clumsy appearance. During the severe weather of winter, as the gardener told us, the shutters of the stoves are kept closed night and day, so that the plants remain in darkness. The shutters of the greenhouse, however, are closed only at night. Fuel, it must be remembered, is a scarce and costly article in many parts of the Continent; and it is believed to be rather difficult to keep up the temperature of a hot-house by means of a fire made with billets of wood. At the same time, the cold is often very intense. In these circumstances, the importance and utility of shutters must be evident. Upon the whole, although these stoves are rather heavy-looking structures, they are the best houses for tropical plants, which we have hitherto met with in our trip. The

collection of plants is very considerable, and the specimens in general are healthy and vigorous.

A peach-house and a vine-frame cannot receive so much praise as has been bestowed on these stoves for ornamental plants. In the former, the peach-trees did not appear healthy; and one cause of this might plainly be traced to the injudicious practice, already more than once hinted at, of making deep pits, for bark hot-beds, immediately in front of the trees; the roots of the trees, being thus cramped and hindered from spreading, and consequently denied their due degree of nourishment. The production of a dozen of bad pine-apples is perhaps all the compensation received for thus injuring the peach-trees. This sort of faulty structure occurs, more or less, in all the peach-houses which we have seen in the Netherlands. The vine-frames were much of the same nature as those at Oyedonck and Wetteren, formerly described (pp. 63. and 79.), and not better managed. The new wood of this year is yet far from being ripe (21st August), and of course little fruit can be looked for next season. The glass covers were at this time wholly removed; and the few bunches of grapes produced, were not likely to acquire either proper size or flavour. The melon-beds were also completely uncovered, and the covers stored in the greenhouse: the consequence seemed to be, that the leaves had been scorched and shrivelled by the sun's direct rays: fruit was not wanting; but as it is well known that the vigour of the plant depends very much on the healthy state of the leaves, the fruit could not fail to be insipid, where these organs were in a great measure destroyed. While we were still in the garden, a heavy thunder-shower began to fall; and to this drenching rain, both melons and grapes were necessarily exposed, in these open frames.

Figs are here produced on small standard trees, resembling spreading bushes. We saw a good deal of fruit, of the blue Ischia variety, and were told that it ripens in the end of September. In November, the shoots and branches of the fig-trees are bent down to the ground, and retained in that situation by pegs: they are then thickly covered with tree-leaves and straw, so as to protect the buds from the severe frosts which usually take place during winter. At the approach of spring, the litter is cleared off, the pegs removed, and the stems supported for some time in an upright position, by means of stakes.

We remarked that a great part of the very extensive walks and borders had been newly raked over this morning, and regretted that the anticipated visit of three Scottish horticulturists had probably occasioned no little bustle to the chief gardener and his assistants, who must have been busily employed in this duty from the earliest dawn. The rain, which for some time descended in torrents, soon reduced the freshly scratched walks to a state of puddle; for they consist of the same soil as the flower-borders. We were thus again forcibly reminded of the advantage resulting from the well-formed gravel walks of an English garden, on which one may pass without the least inconvenience immediately after the heaviest fall of rain. Although no gravel is to be found in Brabant, there is pure sand in abundance; and some benefit would accrue from employing this material in forming the garden-walks.

The apples, pears, plums, and cherries, in the garden here, are chiefly of sorts well known at home. Mr Donckelaar having been in England, we requested of him to specify any good kinds of fruit which he possessed, and which he had not observed in the English gardens. He remarked, that the period of the year at which he had visited Bri-

tain was too early to enable him easily to recognise the different varieties which he saw in our gardens: but, among Pears, he was of opinion, that different sorts of the beurré common at Antwerp were but little known to us; particularly the Beurré d'Or, the Beurré royale, the Beurré d'Hiver (perhaps the chaumontel), the Beurré blanc (or Doyenné blanc), and the Berice Beurré. Our Brown Beurré, we may here remark, seems to be generally known on the Continent by the name of Beurré d'Angleterre. The Virgouleuse or ice-pear, and the Bergamotte de Pâques or Winter Bergamot, he noticed as being favourite fruits at Antwerp: these, though not common in Scotland, are well known in the southern parts of England. The *Delices d'Ardenpont* and the *Passe-Colmar* he described as excellent varieties introduced a few years ago into Brabant: these are still unknown to our British gardens. He mentioned the *Belle de Bruxelles* as a recent production of Brussels, of very promising qualities. Lastly, the *Nouvelle Epine d'Hiver*, he represented as a seedling raised at Antwerp, and which first shewed its fruit in the year 1812; the fruit considerably resembles that of the old winter-thorn, being of a light-green colour, of a large size, melting and sweet. We hope soon to be able (by means of grafts to be procured from Antwerp) to establish these new varieties in the Society's Experimental Garden. Quince-stocks are recommended for them, in preference to any others.—Among the Apples which are esteemed at Antwerp, and which did not appear to Mr Donkelaar to be much known in England, were the following: St Jean d'Or; Roode Renette, or Red Rennet; Grauwe Renette, or Grey Rennet; Peramene, or Pearmain; Berg Renette, or Mountain Rennet; Fine Verte; Calvin Acotes; Pomme royale; the Drap d'Or,—not the Fentouillet jaune,

nor the Golden rennet, both of which sometimes get the name of Drap d'Or, but a large round fruit, of a fine yellow colour, dotted with brownish points, with a light pulp, having an agreeable flavour. To these may be added different subvarieties of the Courtpendu, particularly Courtpendu Pêche, Courtpendu rosart, and Courtpendu à fossette; all of which are large, of an agreeable flavour, fit either for the dessert or the kitchen, and capable of being kept till May or June. A recent seedling apple, said to be of excellent quality, remains to be noticed: it is called *Comte d'Orm*, and was produced at Maestricht about the year 1800. It has been cultivated for some years at Antwerp, but, we believe, is not generally known.—The *plums* afforded no novelty. By much the best was the Reine-Claude or green-gage; and the most common was the Hungarian or blue egg-plum. This last, we may observe, very generally appears in the fruit-markets of Antwerp, of Ghent, Bruges, and even Ostend.

Having discussed the fruit-trees, we shall now, at the risk of being thought tedious, take notice of two or three remarkable specimens of ornamental forest-trees, which occur in the lawns and groves near the mansion-house.

Among these, a majestic *purple-beech* (or black beech, *zwartze beeckenboom*, as Mr Donkelaar called it) deserves the first place. It had been grafted on a common beech stock, about three feet in height. The place of grafting is marked by a wooden ring, which passes round the bole of the tree, nearly in a horizontal plane; so that the purple beech stem seems as if it had been merely set down flat on the stock: perhaps the mode called *peg-grafting* had been adopted. At a foot from the ground, the trunk of the stock, or common beech, measures 10 feet 10 inches in circumference. Immediately at the place of grafting, the trunk of the purple beech measures 9½ feet round.

Eighteen inches higher up, the stem is 7 feet 9 inches in circumference. From the surface of the earth to the setting off of the branches, the bole of the tree is about 12 feet in height. The top branches are between 50 and 60 feet high, and the lower ones cover a space 45 feet in diameter. It was planted in 1752, when this country-seat was originally formed. The tree is altogether of a handsome shape, well balanced, and copiously furnished with branches. To a spectator standing directly under it, the leaves appear nearly of the usual green colour; and they are but slightly tinged with purple, as far as they are excluded from the sun: as they approach outwards, they get a stronger purplish hue; and on the very exterior, they are of a deep purple, insomuch that the tree, seen from a distance, appears almost as if clothed in black. The purple colour of this variety of beech is generally regarded as analogous to the variegation of other trees; but this specimen in its capacious growth and exuberant foliage, certainly exhibits no symptom of debility or disease: it is to be added, that it produces yearly both flowers and seed, and that numerous seedlings arise from the mast shed around. What is further worthy of remark, is, that the greater part of these are purple; Mr Donkelaar even suggested, that the few green-leaved plants which appeared, might result from the mast of common beeches in the neighbourhood, scattered by the winds or by birds. But this supposition is unnecessary; for though a few green plants may appear, the evident tendency of the progeny is to assume the purple foliage. It seems probable, that in many cases this tendency only gradually develops itself; for in a young hedge formed of these seedling plants, we observed every variety of hue, from green to purple; yet no individual was completely green, and none completely purple.

A *catalpa*, situated at no great distance from the purple beech, far excels the specimens of this American tree, which we have already praised (pp. 8. and 10.), at Lambeth Palace and Mile-End Nurseries near London. A short way from the ground, the stem was 8 feet 8 inches in circumference. The bole of the tree was upwards of 6 feet in height before any branches set off. The snag of a large branch which had been amputated, was more than a foot in diameter. The towering branches rose to the height of 35 or 40 feet. The foliage was very large and perfect, not torn by the winds as at London; and the whole tree was at this time covered with its branching panicles of flowers. Another American tree, the *liquidambar* or sweet-gum (*Liquidambar styraciflua*), likewise excelled every specimen to be seen near London. At 4 foot above the ground, the stem measured six feet in circumference; it continued bare to the height of about twelve feet, when it branched out; and the branching part of the tree, somewhat of a conical shape, rose to the height of at least fifty feet. Both of these American trees, we understand, were planted at the same time with the great purple-beech, 1752; and they were the first of their respective kinds which appeared at Antwerp.

It is to be understood, therefore, that the purple-beech, *catalpa*, and *liquidambar*, which have now been described, are regarded as very fine specimens even in the Netherlands. The soil, which is at once light and rich, and moist, seems peculiarly well adapted to their growth. It is to be observed, on the other hand, that neither the weeping willow nor the cedar of Lebanon had here attained their usual size, nor did they promise to do so: they evidently thrive much better in the strong soil of England.

Among the herbaceous plants of Mr Smetz's garden, the collection of *Dahlias* is highly deserving of notice. It is indeed by much the best we have hitherto seen. The double-flowered varieties are planted in clumps in the borders, and produce a very rich effect at this season. No fewer than twenty different sorts, with double flowers, and varying in colour, have, within a few years, been gained from the seed by Mr Donkelaar, who makes annual sowings. Besides these, he has ten varieties with semi-double flowers. Such as come single, are commonly rejected, unless the colours prove fine or uncommon, such as orange, bright yellow, pure white, or very dark purple. The seedling plants of this year were growing in long rows in the kitchen-garden quarter, not unlike rows of beans, or some culinary crop. They were already very generally in flower, and presented considerable variety. All the flowers that we observed, however, were single: but those that come multiply, and are most likely to prove full, are often shy in displaying their blossoms; sometimes, for the first year or two, they only shew the flower-buds, without expanding them; if these be large or bulging, the plant should be kept and fostered in a sheltered border till its character be ascertained. It is only about eight years since Mr Smetz procured a few dahlia tubers from Paris, the first that came to Antwerp; and such has already been the success that has crowned the labours of his diligent gardener, and so favourable to this plant do the soil and climate of this district appear to be, that the dahlias of Antwerp are now in request at the French capital*.—The

* According to a practice not uncommon, we believe, on the Continent, Mr Donkelaar has it in his power to dispose of supernumerary plants of different kinds. The twenty sorts of double dahlias, we found, were thus

only other herbaceous plant which we shall mention, is the *Asclepias tuberosa*. It is here planted in wide-spreading, patches in the manner of the *Lilium superbum* at Mr Hopsomere's near Ghent (p. 70.); and the profusion of bright orange flowers now displayed, rendered it extremely ornamental.

Upon the whole, this seat of Mr Smetz afforded us a good deal of pleasure. The natural beauties are as numerous and diversified as can be expected in a flat country; and the instances of good taste and judicious management, more than counterbalanced those of an opposite description. We have often heard of the riches of Antwerpian bankers and merchants; and the large sums which have here been lavished on the embellishment of these pleasure-grounds, even in revolutionary times, seem to justify the report; notwithstanding the cheapness of labour and of materials on the Continent, they must have been such as would, we doubt not, alarm many an English nobleman. We did not wonder, therefore, that the Empress Marie-Louise should, in the progress which she made with her husband through the extended dominions of France, have spent some days, as she did, at the charming retreat of Mr Smetz.

In returning to Antwerp, we found the by-roads almost impassable, from the rain which had suddenly fallen, and were glad to regain the chaussée; the utility of which in the Netherlands was thus illustrated to our conviction by experience.

sold: for a collection consisting of young plants, in the spring, 100 francs (£4:3:4); and for a collection composed of large grown-up plants, in the autumn, 200 francs. Mr Donkelaar added, however, that when a cultivator of curious plants wanted such a collection, it was always most agreeable both to his master and himself to make an interchange, in order that they might increase their own botanical collection.

Miscellaneous Observations.

To judge from external appearances, superstition is more prevalent here than at Ghent. The corner of almost every street presents a Madonna and Child, the former generally with a dress of glaring colours, and with a gilded glory round the head. These figures are not erected at the public expence; but result from the piety or the repentance of individuals, who appropriate sums of money for these purposes. It is somewhat strange, that they were all swept from the streets by Buonaparte, and have been restored since the accession of the present Protestant King of the Netherlands. Within an inclosure not far from the church of St Calvary, there is a very extraordinary group of figures as large as life: the subject is the crucifixion, and the cross rises more than twenty feet high. The design and the workmanship appear to be good; but the effect on our minds was too painful to permit us to examine the thing as a work of art.

One of us entering the cathedral this afternoon, witnessed the vesper service, and the celebration of mass at one of the side altars. Here for the first time were to be seen a few well dressed females; for so much do the remains of Spanish customs still regulate the practice of the Antwerpians, that it is unusual for ladies to appear on the streets, or even on the Penipierre or principal promenade. One remark with regard to the assemblage of people in the cathedral it was impossible not to make;—the rich and the poor were completely intermingled. In Scotland we have in a great measure stripped our churches of ornament; but our pews, although formed of plain fir boards, are (at least in some places) kept under lock and key, and many a bustling beadle is employed to prevent the genteel part of the audience from be-

ing intruded upon by worshippers of humbler degree. Here, however, the magnificent church of Nôtre Dame, ornamented on every side with altars of the rarest and most costly marble richly sculptured, and with the admirable works of Rubens and Vandyke, is equally open to all : there is literally no respect of persons ; from the moment they enter the portal, all seem to feel themselves on a footing of equality ; the ragged porter was seen kneeling beside the well dressed citizen, and ladies planting their *prie-Dieus* * close by those of the poorest looking women. In the same promiscuous manner, a number of the people approached and knelt around the altar, in order to receive the eucharist. A richly inlaid box (the *expositorium*) was brought forth by the Priest ; a precious stone of considerable size (it is believed, a sapphire) was taken from it, and exhibited to the admiring eyes of those who knelt. No opportunity of learning the meaning of this ceremony occurred to us. The pix was then unlocked, and the consecrated wafers were placed on the projected tongues of applicants of every rank.

A rainy evening prevented us from making particular visits to the remains of the printing-house of the Plantins, and to some ruinous arches which still mark the site of the garden of Rubens ; both objects deserving the notice of the antiquary.

The theatre was at this time open ; and we were amused to observe, that the bills announced a new piece under the title of “ *La Femme à vendre, ou Le Marché Ecossais* ;” the author supposing Smithfield to be in Scotland.

The only newspaper which we have seen here, is the “ *Journal constitutionel, commercial et litteraire, de la*

* Slight reed chairs, so contrived that they answer not only for seats, but, when turned round, for kneeling-desks.

Province d'Anvers," published by Jouan in the Place Verte. It comes forth daily, but consists only of a small folio sheet, which does not contain as much matter as one page of our common English newspapers. Each publication seldom displays more than a dozen of advertisements. The articles of news are always written in French; the advertisements frequently in Flemish. This Antwerp Journal, in what may be called its leading article, constantly evinces the greatest antipathy to Britain. In this way it contrives to give vent to the regret felt for the overthrow of Buonaparte; an event which, notwithstanding his arbitrary measures, seems to be very generally deplored by the Brabantines. As an indication of the feeling of the people here, we may mention, that copies of a paper bearing to be a protest by the Ex-Empress, were yesterday eagerly purchased by the inhabitants, and that to-day the sale is suppressed, and a military guard placed over a stationer's shop in our neighbourhood, where the alleged protest had been sold.

We have already adverted to the care bestowed on the rearing of trees on the margin of the quay. The same kind of taste induces the inhabitants to train vines, and sometimes ornamental shrubs, along the front of their houses in the streets. In a wide lane communicating with Place Verte, our attention was attracted by a very large and ancient vine, apparently of the variety called the Frankendale, planted in the centre of the front-wall of a large house, which it now covers. The pavement of the street (resembling the old style of our *causeway*) reaches close up to the stem, which is secured from being injured by carts or wheelbarrows, by means of a small wooden box. At the height of between two and three feet from the ground, a single branch had originally been trained horizontally to each side, the whole

extent of the house, or about thirty feet in each direction. From these horizontal branches, which are now very thick, and in this respect resemble trunks, many upright branches arise, which are trained vertically even to the eaves of the roof, or between thirty and forty feet high. Notwithstanding the great size of the plant, very few bunches of grapes were to be discovered; but it seemed pretty evident, that the tree is not judiciously managed in respect to pruning. The roots of the grape-vine, it is well known, extend to a great distance in any situation; but doubtless the roots of so large and old a plant must traverse the street, under the pavement, in a very remarkable manner, in order to collect the nourishment necessary to the developement and support of such an exuberance of foliage, independent altogether of fruit. The annexed sketch, taken from Mr Hay's note-book, will convey some idea of this fine old vine.

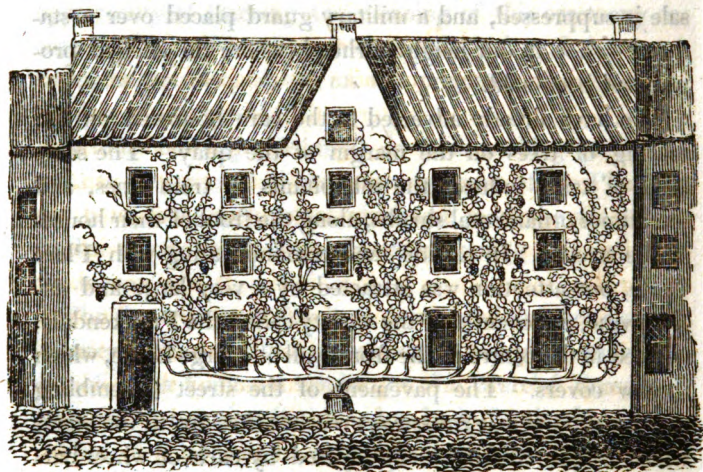

From Antwerp to Rotterdam.

Aug. 22.—At the early hour of four this morning, we took our seats in the diligence for Rotterdam. We were

told, that we should probably accomplish our journey by three in the afternoon, but that, if the wet weather continued, it might perhaps be 5 P. M. before we should reach our destination. The rain had ceased during the night; and, as the morning advanced, the clouds cleared away, and afforded us a view of the country through which we passed. For several miles, each side of the road presented coppices of oak and alder, with occasional fields of corn. Soon after passing Sandvliet, and entering the proper Dutch territory, the soil became poor and waste. Extensive moors and sand-hills continued, with little intermission, till we approached Bergen-op-Zoom. The moorish ground was generally covered with heath (*Erica vulgaris* principally, with a mixture of *E. cinerea*); and at this season it was seen to the best advantage, the heath being clothed with flowers.

Berg-op-Zoom.

After passing many outworks with palisadoes, we came in front of a half-moon battery, flanked by a fort with several redoubts; and crossing, by means of a wooden bridge, a broad canal, formed, we believe, by the river Zoom, we entered the gates of this formidable place, accounted the chef-d'œuvre of the great engineer Coehern, and celebrated for the many sieges it has stood. It was now about 10 A. M., and we had only *done* about six-and-twenty miles in the space of six hours! Our Dutch conductor indeed complained of the slow pace occasioned by the heaviness of the roads, and, by way of consoling us and proving his zeal for furthering our course, would not listen to a proposal of our getting breakfast, assuring us that the *post-wagen* (for by this title the diligence was now to be distinguished) would set out again in a very few minutes.

We had, therefore, only time for a walk to the church and the market-place of a town where so many Scotsmen have fallen, both as defenders and assailants; as defenders at the famous siege by Mareschal Saxé in 1746, and as assailants under General Graham (Lord Lyndock) in 1814. In both cases our countrymen were unsuccessful; but their conduct as soldiers is universally praised.

As we proceeded on our journey, the fields increased in size, and the crops appeared tall and good; but the roads became worse, and the jolting excessive. We had now got among the mud-dikes of Holland. The road, if it deserve the name, generally runs along the top of these; but it often passes from one dike to another, by means of inclined planes, and in descending these we were frequently in jeopardy of being pitched out. After some hard work of this kind, we entered, along with our carriage and horses, a *bac* or large flat ferry-boat, and crossed a small branch of the Maese. We then passed over the Island of Roggenhill; and the road being smoother and firmer, we soon reached

Williamstadt.

This, too, is a strongly fortified place; but the interior presented us with the appearance of a pretty little town, very clean, and of a flourishing aspect. After some little delay, we embarked in a commodious pinnace, in order to cross an arm of the Maese, between three and four miles broad, called Hollands Diep.

On the other side we found another *post-wagen*, of worse construction, and with worse cattle, awaiting us. The roads continued very bad; but the face of the country still improved. The dikes are here very wide or broad. Neat smiling cottages are scattered along the sloping banks. By rearing their houses on the sides of the dikes, the inhabitants raise themselves a few feet above the water, while

their huge thatched barns may often be seen apparently immersed in that element. Fruit-trees, particularly apples, are planted abundantly on the slopes of the dikes, especially near the cottages or houses of the *boers*, for so the farmers here are styled. The Dutch term *boer*, or German *bauer*, it may be right to notice, conveys no reproach, or no more than the term *small farmer* does with us. In Holland, the merchants are the principal people: Owing to the very limited territory of the State, and the still scantier proportion of arable land, farms are necessarily of trifling extent, and, with a few exceptions, the occupiers are far from being rich. The fruit-trees are low-grafted, but they spread wide; often forming very large trees, the branches extending perhaps from fifty to sixty feet in diameter. The greater part has evidently been long planted; probably from sixty to a hundred years. The trees were at this time very generally loaded with fruit; forming a striking contrast with what we had seen in our own country, where the apple-crop had this year failed. We remarked very many trees of the *belle fleur* variety, the brilliant red fruit of which produces a rich appearance; but it is only of indifferent quality. This is one of the kinds very commonly sent to Leith from Rotterdam in wicker hampers.

In the course of our progress into this land of meadows and waters, we had been making inquiries about the *storks* (*Ardea Ciconia*, L.), which every year visit Holland in the breeding season; and we learned that the great flock had taken its departure about ten days before. We observed several of their nests, set like wicker-baskets on the roofs of the dwelling-houses; and we had the good fortune to see one solitary dam still covering her brood, on account probably of the young one not having been sufficiently fledged to enable it to accompany the main body. We persuaded the conductor to allow us to get out of the carriage, and

examine this rarity: the bird shewed no sort of alarm, the *ooyevaar* (as our Dutch friends called it) being privileged in Holland. In many places, where a new house is built, a nest-box is erected on the gable, or on the ridge of the roof, partly to invite the bird to make a settlement, and partly perhaps to save the thatch of the roof, in case it should come without invitation*.

During the after-part of the day, we passed through a well cultivated country. The wheat appeared universally ripe for the sickle; but very little was yet cut, (22d August.) Flax is extensively raised; and a fellow-traveller assured us, that it was the most profitable crop in this part of the States. We were now in the country of Dutch Clover strictly so called, and observed many rich fields of it. The sides of the road were often fringed with alexanders and with wild parsnip, as well as *Eryngium campestre*, and the ditches every where presented *Sagittaria* and *Morsus ranæ*, all of them now in flower.

Instead of reaching our destination early in the afternoon, as promised, we had yet a broad ferry to cross, being what is called the Old Maese; and after this, to traverse the Island of Ysselmond. We were still floundering in

* Previous to the great migration, the storks assemble in large groups, and make an unusual noise. It is known that they winter chiefly in Egypt. Pope has finely alluded to their remarkable instinct:

Who calls the council, states the certain day?

Who forms the phalanx, and who points the way?

In the beginning of May they return, like swallows, to their former haunts, the old birds carefully seeking out their accustomed nests. Sometimes, though rarely, a stray stork crosses the Channel, and is seen on the English coast. It is there incessantly persecuted; it commonly perches on the roof of some thatched farm-house, where its experience leads it to hope for protection,—but it is not the dwelling of a quiet Dutch boor; some pseudo-sportsman of a farmer shoots the poor bird while at roost.—See Supplement to Montagu's Ornithological Dictionary, art. STORK.

the mud-roads when darkness came on; and it was between 9 and 10 at night before we arrived at the *Kattendrecht* ferry opposite to Rotterdam. Having crossed the Merwe, or principal branch of the Maëse, we drove, by our own desire, to the hotel called *Mareschal de Turenne*.

In default of more important remarks, we may here give our readers two cautions, founded on the experience of this day: In the first place, Not to think of travelling this road soon after a heavy fall of rain, for it is then all but impassable: and, in the next place, if, like us, they happen to have no carriage of their own, To lay in some store of provisions for the journey; for, in this respect, the custom of a Dutch *post-wagen* forms a perfect contrast with that of an English *stage-coach*. In England, the most exact arrangements are made for the supply of the traveller's wants; a well spread table every where awaits him, and both postilions and innkeepers would be very loath to allow him to go on without partaking of all the usual refreshments of the day. Here, however, we pleaded in vain for a few minutes respite for breakfast in the morning; the proposal of dining in the afternoon was equally resisted: our conductor and driver would not be treated with any beverage we could devise for them, from coffee to geneva; and it was only by a sort of rebellion that we were suffered to enter a *herbergje* by the way-side, and procure some *brood en kaas, en koud vleesch*, from the landlady. Here, however, if our repast was homely, our curiosity was amply gratified; for our hostess presented us with the first specimen of the true Dutch costumé, of which the head-dress seemed the most remarkable part. Her cap was fixed by two ridiculously large clasps (apparently gold), which hung at her temples like corkscrews; and her ear-rings, also of gold, were somewhat of the shape, and approaching the size, of hens' eggs.

ROTTERDAM.

Aug. 23.—On going abroad in the morning, we discovered that the great annual fair or *kermess* of this place had, after a fortnight's duration, recently closed; many *kraams**, or temporary booths, still remaining in the streets. All that we have read or heard of the neatness and cleanliness of Dutch towns, seems already realised even in this busy trading port. The outsides of the houses are generally painted, and the large panes of the windows are kept perfectly transparent. Before seven in the morning, maid-servants were every where washing the streets before their masters' houses, with mop-besoms, or dashing water against the windows with a kind of force-pump. The streets are paved with stones similar in quality to those used in Edinburgh, but rounder, and worn smooth with the friction of sledges, which are here in common use. In the principal streets there is a pavement for foot-passengers, made with the small light-coloured and very hard-burnt bricks called *clinkers*: these, placed sideways, form a very compact and durable path. Cargoes of these Dutch *clinkers* are sometimes imported into Britain, for forming the floors of stables, to which purpose they are well adapted, particularly in being durable. In several of the streets the gutters are covered with boards which can be raised at pleasure, being attached to curb-stones by iron-hinges.

* The *Crames* of Edinburgh have at length (1817) been demolished, and the name will be unknown to the next generation. It seems probable, that, like the *kraams* of Holland, they were originally only temporary booths, adjoined to the walls of the Cathedral Church of St Giles, perhaps during the continuance of All-hallow Fair, but which, by gradual encroachments on the one hand, and remissness on the other, had been allowed to become permanent erections.

Not a few Scottish merchants have settled in this commercial town. To some of these our friends had given us letters of introduction; and they received us as countrymen would wish to be received. Mr Ballingal, formerly of Leith, was particularly obliging, in conducting us personally to some of the principal places deserving the attention of strangers.

From him we learned that at Rotterdam, or around the town, there are no nurseries of any note; and the trifling nature of the ornamental plants exposed for sale in the market-place, convinced us that the business of a florist-cultivator is scarcely known here. A single dealer in flower-roots had erected a temporary booth in one of the streets, for the sale of his vegetable wares. His visible stock was not large; and we found that the bulbs of the hyacinth and polyanthus-narcissus, when thus sold in retail in Rotterdam, bore nearly the same price as in Edinburgh.

Van Schenen's Garden.

Mr Ballingal took us to a garden remarkable for containing a large collection of curious plants. It belongs to the Heer Van Schenen, a gentleman far advanced in years, but who still takes pleasure in the cultivation of his rarities*. Over the garden-door, are painted the words *Hortus Botanicus*. We descended some steps to it, and soon observed that the waters of the canal whose bank we had left, were more than on a level with our heads. This is a common case in Holland; but it had not before so distinctly presented itself to us. The garden would be considered as of very small dimensions for a botanical repository, any where else than in the neighbourhood of a

* We understand that this venerable cultivator is now no more, and that his garden and botanical collection have become the property of M. Bicker of Rotterdam.—August 1819.

crowded Dutch town. The number of different herbaceous plants is very considerable ; and it can only have been by great and long continued assiduity, that such an assemblage has been brought together. There is a small greenhouse for the more tender plants, which are kept in pots, but the merit of the garden rests on those which are hardy. The soil is rich, and at the same time very friable, being a mixture of vegetable mould with fine sand. In some places, the cleanings of the ditches had been used in forming the borders. Small as the garden is, room is found both for a piece of rock-work and an aquarium, and these are furnished with suitable plants. The shrubs and trees are necessarily very limited in point of number ; but still there is a select variety of these. Even fruit-trees are not wanting. The fig-tree is here treated as a standard, and we were told that it generally ripens its fruit.

The only other garden, perhaps, deserving particular notice, is that of Dr Daalen. We had not the good fortune to see the Doctor, who, we understand, is very attentive to strangers who wish to see his botanical collection. We may mention, that to a friend of ours, Dr Daalen stated, that he had found the application of ashes to the roots of the *Hydrangea hortensis*, effectual in causing the production of the fine blue colour sometimes observed on the flowers of that plant. Dutch ashes, it will be remembered, are chiefly from turf. The Doctor added, that he regarded the ash of the Norway spruce, billets of which are often used for fuel, as more effectual in producing the blue colour of the petals than the common turf ash.

The Cingle.

We walked along a part of the *Cingle*, which is a broad rural road surrounding the city, somewhat in the manner of the Boulevarts of Paris. We entered the Doelen, a

sort of Vauxhall Garden, where great preparations were making for a gala entertainment to be given to-morrow (Sunday) evening; for although the Dutch are Presbyterians, and attend church regularly, the bulk of the people seem to consider the Sabbath as ended when the afternoon service is over, and devote the remainder of the evening to amusement. In the course of this excursion, we saw several of the fanciful little gardens and garden-houses belonging to the middle class of merchants, and to which they retire in the summer afternoons. All of them are immediately on the exterior of the town, and the windows of the summer-houses invariably look out upon the wide-spreading meadows which surround it. Many of these spots are kept in trim order. The walks are laid with fragments of shells, or with pounded bricks. The edgings are composed either of the usual materials, box or thrift, or of some shewy annual plants, such as ten-week stock (*Malcomia maritima*); and sometimes they consist of low boards, painted green, or of lattice work of the same colour. Ornamental border-flowers are nursed with care, and not a weed is suffered to appear. Fruit-trees are not neglected. Besides apple and pear, plum and cherry trees, all of which are generally kept dwarfish, we observed some standard mulberry-trees, now in fruit. Mulberry-trees, however, are more generally trained against the walls of houses. One peculiarly fine specimen of this kind, belonging to Mr Vermeer, a market-gardener, attracted our particular notice: it is trained along the front and roof of his house, and its branches completely cover and conceal both. We were told that the fruit of this tree has in some years been sold for a sum equal to £40 Sterling. Grape-vines are likewise commonly trained against the walls of the houses in the outskirts of the town; and we were assured that they

often prove very productive. Near the East Port, the roof of a long shed, apparently devoted to the cover and protection of the public ash-carts (*karre-hok*), and extending about 200 feet, was thickly clothed with vine branches, which were at this time tolerably well loaded with fruit. There were in all six plants, which grew in the open area next the street; we observed both white and black grapes. The latter were the most numerous, and we were told that they were of the kind called Blue Frankendale (*Blauwe Frankendaler*): the name of the other we could not learn. It seemed very doubtful if the fruit would this year come to maturity; but we understood that it ripens in favourable seasons.

In returning homeward, we crossed one of the *heads* in a *doyt*-boat. Both of these terms may probably be thought to require explanation; and it may be given in a very few words.—The canals in which the water is maintained at the level of the Maese, are called the *heads*. Into these the water from all the lower canals, drains and ditches, is thrown, being raised by means of bucket-wheels, operated upon by wind-mills.—Notwithstanding the number of draw-bridges on these canals, small ferry-boats are stationed at particular places, and are continually plyed, backwards and forwards, by means of a rope: the freight is one *doyt*, or the eighth part of a penny; and hence the name *doyt*-boat.

A stranger does not at once perceive the dikes of Rotterdam, which yet are essential to its safety: they are chiefly covered with houses; for instance, the populous and crowded High Street is a dike in disguise.

Aug. 24.—Whenever we walked out this morning, we felt that we were again in a Protestant country: the shops were shut, the streets quiet, and the labouring people, in their best suits, were repairing to church. By 10

o'clock, the Grootte Kerk (in Catholic times St Laurent's) was well filled. Excepting in the use of the organ, the mode of worship very nearly resembles the Scottish. The instrumental music, it should be remarked, however, is here kept subservient to the vocal, in which the congregation unanimously joins. The sand-glass, which used formerly to make a part of the furniture of our Scottish pulpits, but has now been generally laid aside, is here still retained. The clerk, too, here continues to discharge that part of his duty which consists in reading aloud to the people the Sacred Scriptures, till the minister enters the pulpit; a good old practice which has fallen into disuse in the church at home, where he now merely acts as precentor. The offering is collected from each individual, during the time of service, by means of a velvet-purse attached to a long rod. The tinkling of a small bell connected with the purse is continually heard, but does not seem to disturb Dutch devotion. Two offerings are collected, in distinct and differently coloured purses; one for the "poor," another for the "kirk," this last having been rendered necessary in consequence of some of the arbitrary regulations of Buonaparte, by which the usual funds for the repairs and other necessary expences of the churches were swept away.

After the morning-service, there was a parade, in the market-place, of a regiment of the Burgher Guards, wearing a uniform not unlike that which characterised the earliest corps of Royal Edinburgh Volunteers.

Mr Schuurmans' Villa.

Mr Macdonald and I paid a visit to Mr Schuurmans, an eminent wholesale seedsman of this place, to whom we had a letter of introduction from Messrs Dickson & Co, of

Edinburgh. We found him at his snug suburban villa, on the south bank of the Schie Canal, enjoying that repose (approaching, in our eyes, to apathy) in which Dutch gentlemen advancing in years are said to find the sum of human felicity. He received us courteously ; and lost no time in passing a formal but evidently sincere eulogy on the Dicksons of Edinburgh, for the extent and punctuality of their dealings. After wine and cake had gone round, he descended with us into his little garden, which was many feet below the level of the great canal. We considered it as probably affording a fair specimen of the better sort of the Rotterdam gardens. Besides flowers and shrubs, it contained several fruit-trees, some trained as standards, and some on espalier-rails. The standards were of two kinds. The first, Mr Schuurmans called *Arbonijns*: these are open in the centre like a cup, to which shape they are brought by tying them to a hoop ; and they have very short stems. The other he called *Kroon-boomen* or Crown-trees: these have tall stems, 6 or 7 feet high, and a few horizontal branches at top ; the horizontality of these branches is induced, by tying down the young branches towards the stem by means of twigs. For the small Dutch gardens, apple and pear trees are almost universally grafted on paradise stocks, and trained as Crowns or as *Arbonijns* ; which last may be regarded as crowns with dwarfish stems. Cherry, apricot, plum and mulberry trees are never trained in these forms. It may be remarked, that on the flat low grounds, with light sandy vegetable soil, fruit-trees soon begin to decay ; for such situations, trees grafted on paradise and creeper stocks are therefore with propriety selected ; they come sooner into bearing, and occupy much less space. On the slopes of the large dikes, trees grafted on freestocks are preferred to the former : because they

have here a good wheat-soil to grow in ; the roots do not reach the stagnant water ; the trees endure for generations ; and the branches have room to spread in every direction. In this garden we saw the *Heere Appel*, or Gentleman's apple : it is large, and, as Mr Schuurmans told us, good for the dessert. He pointed out to us two pears which he highly esteemed : one of these he called *Grand Bretagne*, and this seemed nothing else than our Black Achan : the other he named *Jutte peer* ; this was new to us, and appeared of very promising qualities, for it was not yet ripe : about the etymology of the name we are not certain ; possibly it may have originally come from Jutland.

Having rejoined Mr Hay at the table d'hote of our inn, we went together in the afternoon to the *Scottish Church*, for which two pastors (the Rev. William Macphail and the Rev. James Anderson) are provided, and paid by the Dutch Government. The former at this time officiated. The worship was quite similar to what we had been accustomed to at home ; and to meet with this in a foreign land was pleasing enough. We afterwards, by invitation, spent the evening with the two Reverend Gentlemen. In walking homeward with one of them, along a part of the Cingle, we came to a continued series of garden-houses, nearly a mile in extent ; these miniature villas being separated from each other only by wooden partitions, which are generally neatly painted. Mr Anderson mentioned, that around Rotterdam there are about eight hundred such villas, (*twin-huisjes* or *lust-hofs*). We looked in upon several, where we could do so without intruding, and saw several well-dressed people, generally seated ; the ladies frequently regaling themselves with coffee, the gentlemen with pipes ; both in the open air, or in summer-houses with the windows thrown wide open.

We spent some time at the country house or *buyten-plaats* of a relation of Mr Macphail, who, having retired from the sea-faring line, now amuses his leisure in the management of his fruit-trees, on which he makes many experiments. He mentioned to us, that, some years ago, his trees had been much infected with the white insect, but that, by repeated washing with a brush dipped in the pickle of salted herrings, he had succeeded in thoroughly cleansing them.

Vegetable Market.

Aug. 25.—Early this morning, Mr Macdonald, having been on the alert, witnessed the opening of the green-market, and the arrival of many punts or long narrow barges which had come down the Rhine and the Maese, some of them from a great distance, particularly from places in the neighbourhood of Arnheim and Ghorcum, loaded chiefly with new potatoes: these were commonly stowed in the hold, but packed in sacks; each sack containing about two Scots bushels. The potatoes were in general of a diminutive size and round shape; and they were brought to market unwashed. From their appearance we should not have pronounced them very good; but our countrymen in Rotterdam informed us that they are, in general, of excellent quality. On the decks of the same vessels, were many small hampers containing apples and pears: these hampers were netted over, so as to admit air, but prevent the fruit from falling out. The ripest and largest apples were of the well known variety called Dutch Codlin. The Red Calville and the White Calville were both in large quantities, and likewise very good. The baking apple, called with us *Fail-me-never*, was pretty abundant; but not nearly ripe. The apples are very generally brought from the province of Guelder-

land. The different kinds of kitchen-vegetables (or *moeskruiden*, as they are here styled,) are not of such excellent quality nor so plentiful as at Ghent. Although it is late in the season, Cauliflower is still pretty good, and superior to what we saw at Antwerp: the heads are large, and have indeed stood too long in the garden. The plants had been cut over close by the ground, and were now brought to market with all the large leaves attached, and wrapped around them. This precaution is perhaps judicious, on account of the extraordinary distance from which they are often brought. From Mr Anderson we learned, that though the best season for cauliflower was considered as past, the cultivation of this article is so extensive, and the supply poured into Rotterdam so great, that whole barge-loads continue to arrive almost every day for several months; and that cauliflower is still to be found in the market during the first part of winter. Carrots and Parsnips were plentiful, but not so large and clean as at Antwerp. Scorzonera seems to be rather a favourite. The green legumens of the large white-flowered variety of Kidney-bean, often called Dutch Runner, were plentiful, under the name of the *snyboontjes*. They were generally exposed for sale in wide baskets, capable of holding several bushels each. For the most part the legumens were so large and old, that they would have been deemed useless in Scotland, as being tough and stringy; but in Holland they are nicely shredded down, so as to render them, when cooked, extremely palatable. Cucumbers were not uncommon; but the white variety was the only kind to be seen. The Brown Dutch Lettuce was very plentiful, as well as the Berlin Cabbage-lettuce: But the fine Green Coss seems unknown here; at least it did not appear in the market; nor indeed did we see it at Antwerp, or at Ghent; we recollect only to have observed it sparingly at Bruges.

We spent most part of this day in a general desultory survey of Rotterdam.

We were rather surprised to find that the *fruit-shops* were few, and but ill supplied. Apples and Pears were indeed cheap and common; but the apples were not in general ripe, the kinds chiefly cultivated in the farmers' orchards being late or winter fruit; and the pears were of indifferent quality. The *sugar-pear* was perhaps the most common, and it was uniformly mealy and tasteless. The Plums did not merit attention. All the finer kinds of fruit were rather scarce and high-priced, being solely furnished from private gardens; none of them appeared to be of superior quality. We had some recollection of the way in which Mrs Radcliffe disparages Dutch gardens and fruits*, and began to suspect that it was not to be ascribed merely to her desire of turning a period in the Johnsonian style, but was better founded than we had supposed. Making a morning call at Mr Ballingal's, however; we were presented with a basket of Mulberries, the produce of a Rotterdam garden, which must be excepted from the general censure; for, both in size and flavour, they could scarcely have been surpassed; and we were told that very fine Peaches are produced in many of the gardens of the principal merchants.

In the *book-shops* we were unsuccessful in procuring any work whatever on the gardening of Holland; and we were told, that no publication on any branch of horticulture has of late years issued from the Dutch press.

* The passage alluded to occurs in her *Journey*, &c. p. 18. "By the effects of soil and climate, Dutch gardens are deprived of value: for the moisture is so disproportioned to the heat, that the verdure, though bright, has no fragrance, and the fruit, at its utmost size, scarcely any flavour."

We visited the *Exchange*, which consists of a suite of buildings forming a square. Soon after 2 o'clock, the court and piazzas were crowded with merchants, many of them, we were assured, of great opulence. We were not a little surprised to learn, that these gentlemen had already returned from dinner to the prosecution of business. The dinner-hour of olden times, 1 o'clock*, is still continued in Holland: the Dutchman rises from table before the cloth be drawn; the practice of drinking wine after dinner being unknown. From 'Change, he returns home to tea and coffee between 3 and 4 o'clock: he then again resorts to his counting-house, where he spends a few more hours in business; and supper is the only meal at which he indulges in any degree of relaxation.

In apartments over the piazza of the Exchange, belonging to the Batavian Society of Rotterdam, we were shewn a set of philosophical instruments, with numerous models of various kinds, some specimens of minerals, and a few natural curiosities. We understood that lectures on natural philosophy and on chemistry are occasionally delivered here. The models seem to form the most interesting and important part of the collection.

Statue of Erasmus.

The bronze statue of the celebrated Erasmus has often been described. It is situated at a bridge in the Great

* Mr Creech, in his *Sketches of the Changes of Manners in Edinburgh*, informs us, that the shopkeepers of that city used, in the early part of the eighteenth century, to shut their shops from 1 to 2 o'clock, when they went to dinner. The musical bells of St Giles's are still chimed during that hour, although many of the present generation scarcely know that this diurnal carillon was originally intended to gratify the ears of their forefathers while they dined.

Market-place, not far from the house in which he was born in 1467. The figure, which was executed by De Kieser in the beginning of the seventeenth century, is larger than life, and produces an imposing effect. Erasmus is represented supporting an open quarto with his left hand, while he is turning a leaf with his right. He is dressed in a furred gown, with a round cap on his head. Upon the whole, the artist has conveyed a forcible idea of this "glory of the priesthood, and the shame;" but his work has been strangely disfigured by some ignorant painter, who has passed his unhallowed brush over the bronze. A singular anomaly struck us here: while the inhabitants are scrupulously nice in keeping the streets opposite to their own doors perfectly sweet and clean, they suffer the space around the pedestal of this fine statue to be contaminated in the most offensive manner.

Rhine Barges.

Some very uncommon-looking vessels, of large size, but evidently destined only for internal navigation, attracted our notice. They were Rhine barges. Being of great length, and almost flat-bottomed, their tonnage is vast. We entered one of the largest, belonging to Cologne, which, we were told, was between 500 and 600 tons burden. The stern part of the vessel was fitted up as a china and earthenware shop, and the display of goods was most extensive and various. Towards the centre of the ship was a commodious and elegant cabin, the floor of which was on a level with the deck. The apartments consisted of a state-room, several bed-closets, and a kitchen. On the outside of this raised cabin, and in front of it, it was amusing to see a washing-green and garden in miniature; muslin gowns drying amidst pots with shrubs and flowers. In explana-

tion of these appearances, we were informed, that the whole family often migrates with the vessel, dwelling on board for many months at a time.

Large Trees.

We have not yet mentioned the trees of Rotterdam ; but they must not pass without notice. In the Austrian Netherlands, we had scarcely seen a forest-tree more than thirty or forty years old. On entering the territory of the United Provinces, large trees, chiefly elms, alders, and willows, began to appear, marking the lines of the principal dikes ; and at Rotterdam the quays are adorned with elms and limes of more than a century's standing. The finest quay in the place, which stretches three quarters of a mile along the bank of the Maese, is named, from the trees which fringe it, *The Boomptie*. From the diminutive termination being added to the word *Boom* (tree), it seems reasonable to conclude, that this quay had been the first planted, and the name bestowed while the trees were small and young*. At this day they are generally about fifty feet high, with boles extending nearly to the half of that height ; and most of them are evidently a great deal more than a hundred years old. With the exception of Yarmouth, scarcely any of our British ports possess trees on their quays ; and whoever has seen the trees on the quay at Yarmouth, will admit that they are highly ornamental, if not useful. We had witnessed the care and expence bestowed at Antwerp in planting and protecting young trees ; and after seeing the charming effect of full grown elms at Rotterdam, we were no longer surprised at

* I observe that some tourists consider the name as signifying The Quay of Trees ; but in this case, it would have been written *Boomkaai*.

that care and expence. It was painful to reflect, that a very different feeling in regard to trees, has long prevailed at Edinburgh. Instead of planting, we had seen our city rulers, but a few years since, apply the axe to the noble amphitheatre of full-grown trees which skirted the grounds of Bellevue, and which would now have formed a most desirable and highly ornamental boundary to the New City on the north-east. A better taste, and more liberal views, are now gaining ground. As an evidence of this, it may be noticed, that the plans for extending the city to the eastward have been so contrived, as to preserve the large trees on Leith Walk. After seeing the effects of trees on some of the dikes of Holland, we cannot help remarking, that the appearance of the ponderous and clumsy Earthen Mound at Edinburgh might be greatly improved by planting its sloping sides; and we may add, that the dull aspect of the low marshy ground which once formed the North Loch, might be remedied, by partly covering it with alders and willows*.

* The fine elms at Rotterdam are of the kind called by us *English Elm* (*Ulmus campestris*). At Edinburgh it may be better that the *Scots Elm* (*U. montana*) should chiefly be planted. This last is always raised from the seed in Scottish nurseries; while, in these nurseries, the English elm is generally propagated either by grafting on the Scots, or by means of layers. By grafting or by layering, plants of English elm fit for sale from the nursery lines are more speedily obtained; but they seldom form such fine trees as plants sprung directly from the seed, and, being destitute of the tap-root, they are less fit for exposed situations. Seedling Scots elms, by means of their long descending roots, will establish themselves in very bleak places, open to currents of wind. The *sycamore*, (or plane-tree of Scotland, *Acer pseudo-platanus*), having large spreading roots, is well adapted for shallow and rocky soils, such as occur on some parts of the new road across the Calton Hill, which might be ornamented with trees. The *mountain-ash*, (or roan-tree of Scotland, *Sorbus aucuparia*), the most ornamental native tree of the Highlands, is likewise excellently suited to such situations. To it

During summer the Boompie forms a favourite promenade of the inhabitants; the trees affording shade, while the river very generally ensures a circulation of cool air. For the benefit of our countrymen who, in visiting Rotterdam, may wish for the best accommodation which the place can afford, we may mention, that this is to be found in a hotel called The Bath *, situated on this grand quay. The principal merchants, it may be added, have their residences here; including several of our own countrymen who have settled in Rotterdam; and in a country like Holland, the situation may be considered as beautiful: the houses front the south, and the windows look out upon the Maese, here a majestic river, with vessels of every size and description frequently passing up and down; the view of which is perhaps enhanced by being partially intercepted by the row of trees just described.

Before leaving Rotterdam, we may notice, that the

may be added the *common ash* (*Fraxinus excelsior*), and the *Norway maple* (*Acer platanoides*), which fringes the Norwegian hills down to the margin of the sea.

* Here we learned that a very select party of our countrymen, consisting, among others, of the late Lord Chief-Baron Dundas, then on his way to the south of France, Sir William Rae, Baronet, (now Lord Advocate of Scotland), Principal Haldane of St Andrew's, and Mr Stevenson, civil-engineer, had recently spent some days at Rotterdam, but that they had left that city about a week previous to our reaching it. A highly interesting account of the excursion of this party, or of some members of it, through North and South Holland to Antwerp, has since appeared in various numbers of the Scots Magazine (published by Messrs Constable & Co.) for the years 1819 and 1820, under the title of *Journal of a Visit to Holland, &c.* The sketches of character in these letters are lively and just, and the pictures of scenery remarkably correct. The description of the great sluices at Catwyk is, we believe, the only account in the English language of these national works; and as it is evidently from the pen of one versed in such undertakings, we conclude that the whole of these letters may be ascribed to the distinguished civil-engineer mentioned as forming one of the party.

houses are generally high, and that the upper part of the front walls of many of them, particularly in the narrow and older lanes, projects so much, that it is not at first easy for a stranger to divest himself of the apprehension of their being ready to fall forward into the street. Modern houses seem to be built by the plumb-line, and they afford a criterion by which to estimate the deviation from the perpendicular in the neighbouring tenements of earlier date. This projection above, we were told, was not only intentional, but was enjoined by a municipal regulation, being calculated to throw the eaves-drop from off the wall, and so to prevent damp. It is to be observed, that the strength of Dutch houses depends much on the timber-work; and of so little importance is the front-wall of brick, that it is in some cases not filled in till after the house has been otherwise completed. Of this fact we met with an instance in the course of our walk through the city, in the only new or unfinished building which we recollect to have observed.

At Rotterdam, as at Antwerp, the public lamps are suspended by ropes, which pass across the street; but an improvement introduced by King Louis still continues to be adopted: glass lenses containing water are so disposed in the lamp, as greatly to increase the quantity of light shed abroad.

In the evening, Mr Macdonald and I visited the *Schouwburg*. The inscription on this place of amusement struck us as peculiarly characteristic of a plodding commercial people: *Door yver vrugt vaar*, "Through diligence riches." Certainly nowhere but in Rotterdam would such a motto be considered as appropriate to a theatre. Of the performances we can say little: they were chiefly pantomimic, and to us they were entirely so. The convenient arrangements of the parterre seemed characteristic of the people: there

could be no crowding, each place being numbered, and the forms are not only provided with cushions, but furnished with backs to rest upon. Coffee and cake were handed to those who desired such refreshments. The orchestra was full, and the music good. We remarked that the person who seemed to act as leader of the band merely beat time, without playing on any instrument.

We now prepared to leave Rotterdam, being anxious to get forward to Leyden and Haarlem, which we hoped might prove more fertile in horticultural productions.

The striking characters of this place have already been incidentally alluded to.—One of the most important of these consists in the *deep canals*, admitting large ships into the very centre of the city, and rendering it wonderfully commodious for foreign commerce. The three head canals, the *Leeve havn*, *Oude havn*, and *Nieuwe havn*, communicate directly with the *Maese*, and are furnished with formidable sluices to prevent too great an influx of water in time of floods.—The *sledges* for the conveyance of merchandise, were new to us. They are drawn by strong well-fed horses, generally of a shining black colour, and with tails almost sweeping the ground. These animals are so high shod, that the hoof does not come within half an inch of the ground; and as they pace along, a noise is thus produced like the clinking of heavy pattens. In front of the sledge, a small barrel of water is so adjusted, that a portion of the water constantly trickles out and wets the causeway over which the sledge is to pass. The friction is thus considerably lessened, and at the same time the streets are in a great measure kept free from dust. When the sledge is unloaded, the driver generally steps upon it, and thus moves along at his ease, with his pipe in his mouth.—The appearance of the *windows* of the houses in general pleased

us much. They are commonly large; the glass is of fine quality, and kept bright and transparent; uniformly displaying within curtains of snowy whiteness, either neatly fringed or in rich folds. At the windows of the first floor, the ladies of the house may generally be seen seated, employed in knitting or sewing, or other *vensterwerken* (window-works), and now and then taking a peep into the little mirror placed on the outside, as at Bruges and Ghent. The ladies, we believe, seldom walk out excepting to the church or the fair; we have seen scarcely any abroad but on Sunday.

Although the kermis was past, the market-places were still partly occupied by *vertoonplaatsen* or temporary theatres of various descriptions, all of them most formally announcing, at the top of their bills, the special permission of the "Vel Edele Achtbare Heeren Burgemeesteren" of Rotterdam. The phantasmagoria was announced, with true Dutch sincerity, as "Begoocheling van het Gezigt," Deceptions of Sight. A small tent contained some figures of ingenious mechanism; among others an imitation of a canary-bird, which the advertisement mentioned, with equal simplicity, as a "doode (dead) kanariëvogel," which whistled fourteen airs.—The few kraams for merchandise which still remained were furnished with goods evidently of first rate quality, and many of them of English manufacture. A Dutch kermis is very different from a modern Scottish fair: the former is attended not only by all the principal people of the town in which it is held, but by all the families of distinction to a great distance around. Many wafelkraams, or small tents for the manufacture and sale of wafel-cakes and kermiskoeks, still remained, and seemed to be well frequented.

The Dutch appear to deserve the character given them of being an orderly, sober, and quiet people, remarkable

for keeping regular hours. When Mr. Macdonald and I returned home from the Schouwburg, soon after 10 o'clock, the shops were shut, and the streets hushed. Only the far-famed music-houses or *spesl-huizen* were open, under the license of the burgomasters, and having their entrances signalled by large reflecting lamps: in passing these, we no doubt heard the noise of mirth and dancing, but we witnessed no instance of ebriety nor of unbecoming behaviour.

From Rotterdam to the Hague.

Aug. 26.—Precisely at 7 A. M. the bell rang for the departure of the treckschuyt for Delft, on the Schie canal already mentioned; and here we began to travel by that mode of conveyance. It is not only easy and pleasant, but to a hurried horticulturist, peculiarly desirable. The canals being every where on a higher level than the country, and at the same time brim-full, the passenger who seats himself on the top of the *roef* or cabin, is so much raised that he sees in every direction; and further, it so happens, that, in the country of treckschuyts, all the best villas and gardens are situated close to the sides of the canals. In the first part of our course, we passed many saw-mills, flour-mills, and mills for raising water from the meadows, all put in motion by the wind: in front of most of them may be observed some distinctive emblematical figure, frequently clumsy enough. The fields presented the appearance of rich old pastures; and there was scarcely any corn. The cry of the *peewweep** continually assailed our ears, great numbers of this bird frequenting the moist pastures of Holland during the autumn. The chattering of starlings (*Sturnus vulgaris*) was equally constant, and small

* The Scottish name of the lapwing, *Tringa vanellus*.

flocks of these birds were commonly to be seen perched on the mills. We observed several milk-carts going to town at a round trot, along the high-road, which skirts the canal, each containing three or four huge, brass flaggons, bright as burnished gold. On the margin of the canal, reeds (*Arundo phragmites*) grew luxuriantly: we remarked that in many places, these had been more than once cut over, and we learned that a kind of coarse hay is in this way made of them. When allowed to attain their full size, they are used for thatching barns and mills, and are said to form very durable roofs. As we approached Delft, neat country-houses, surrounded by gardens and shrubberies, became common. The name of the villa is usually painted on a board presented to passengers on the canal; the proprietor seldom misses this opportunity of quaintly intimating the complacency and happiness he enjoys in retiring to his pigmy domain; and not unfrequently he betrays his characteristic attachment to quiet repose. Some of the inscriptions which we observed, were, *Lust tot Rust*, Delight with Rest; *Buiten Rust*, Country retiring-place; *Nut by Vreugde*, Benefit with Joy; *Ons Genoeghe*, Our Sufficiency or Content,—the heads of the family being supposed to speak; *Noit gedagt*, Never thought,—intimating that the owner had unexpectedly realised his hopes of rural retirement. *Roden-Rys* appeared in one place; and as this is good Scotch for “Roan-tree branches,” we presume that the place has been so named from some mountain-ashes existing there. The terminations *lust*, delight, *zigt*, prospect, are very common; as *Kenk-lust*, church-delight, *Land-zigt*, country-view.

When within a short mile of Delft, we came to a large public building, situated near to the canal, and surrounded by water, which our skipper explained, by dumb show,

and by imitating an explosion of combustible matter, to be the general magazine for gunpowder in Holland. Historical events, we find, are familiar to the common people here ; for our friend afterwards pointed out to us the place where the magazine formerly stood, when it exploded and destroyed a great part of the town, in 1654.

Delft.

We had often heard of Delft-ware, and expected to enter a pottery-town somewhat inferior probably to Newcastle-under-Lyne. We were therefore not a little surprised at the magnitude of this place, which is three or four times larger than the English town mentioned. Delft is between nine and ten miles from Rotterdam, and proved a two hours stage. Having breakfasted, we took a lounge through the streets, and, attracted by the beauty of the steeple, we directed our steps to the Nieuwe Kerk. Here we were invited to look at the splendid monument erected by the nation to William, Prince of Orange, who was assassinated in a house in Delft, hard by the church which now contains his monument. This fine piece of sculpture has often been described : we were particularly struck with the success of the artist in depicting the attachment of the faithful dog, stretched at the Prince's feet. We felt no little interest in examining the less showy tomb of Hugo Grotius in the same church. Having sent for the beadle, we got access to the lofty steeple ; and the day being serene and clear, we enjoyed a most extensive prospect from a balcony near the top, surrounded with hundreds of carillon-bells. The districts of Delftland and Schieland lay spread below us like a map. In the direction of Leyden, water prevailed very much, all the *veen* or fenny places from which turf has been dug for fuel being now covered

with water. The Sootermerse Meere was well seen, and, in the distance, the inland Seas of Leyden and Haarlem appeared. We paid a visit also to the Oude Kerk, and saw the monuments erected to the philosopher Leuwenhoeck of animalcular celebrity, to Admirals Van Tromp and De Heine, and to a Lady Meruix, whose history we have forgotten. We remarked that small villa gardens are numerous at Delft, many merchants having chosen this spot for retirement; but we could hear of no garden peculiarly distinguished for its excellence; nor do we think that Delft is likely to afford any thing interesting in the way of horticulture. What is called the *Wyn Appel* seems here to be much cultivated: we may add here, that a horticultural friend informs us, that he regards it as the same variety which is called in England *Sops of Wine*, from the reddish tinges of its pulp.

In the course of the forenoon we again took our places in a treckschuyt for

THE HAGUE.

The approach to this place is really beautiful; and the chief part of the beauty depends on the trees. With these the roads, in various directions, are bordered, to the extent of several miles; and they seem to unite in a great mass of forest, north of the town. Having thus been at first judiciously disposed, they have also now attained to noble dimensions. We knew well that the Hague had long been the seat of government; and although, like Manchester, it ranks only as a village in books of geography; we were aware that it must be a considerable place; none of us, however, expected to be ushered into so large and elegant a city as we

found it to be. Having inquired generally for a "goed logement," we were conducted to a splendid hotel, called Vieux Doelen, situated in the fine place or square of the Voorhout.

The Mall.

In the centre of this place is the Mall, which consists of two broad walks, laid with broken sea-shells, chiefly of the genera *Cardium* and *Macra*, and shaded with several rows of lofty lime-trees; the whole being railed in, so as to exclude horsemen and carriages. The Mall is, we believe, a favourite promenade, when the King resides and holds his Court at the Hague; but at this time it was comparatively deserted. The *ci-devant* Austrian Netherlands and Holland are, according to the new constitution, alternately to enjoy the residence of royalty for the space of a year. The King is now at Brussels; and his expected arrival in a few weeks at the Hague, is hailed as an auspicious prospect.

Here the external signs of loyalty to the House of Orange are even obtrusively displayed; at Ghent we scarcely saw a single orange cockade; a very few began to appear at Antwerp; at Rotterdam they were not uncommon; here they are universal.

What a lesson of caution in changing the government of a country may be derived from the experience of the Dutch during the last thirty years! They began, before the era of the French Revolution, by vituperating the House of Orange, and were quickly successful in dismissing the Prince. So high did party-spirit then run, that grave burgomasters, in testifying their hostility to the name of the Stadtholder's Family, rendered themselves ridiculous, not only by eradicating marigolds from their gardens, but by prohibiting the

sale of oranges and carrots in their markets, on account of their aristocratical hue ! The successors of the men who, by their unanimity, courage, and real devotion to liberty, had been able to throw off the Spanish yoke, forming now a divided nation, fell an easy prey to the French ; under whom they suffered most severely, till the wonderful events of 1814 enabled them to receive back their Stadtholder, whom they now greeted as a King, with exulting shouts of *Oranje boven*.

The House in the Wood.

Late in the afternoon, we took a walk to the northward of the Hague, on the Amsterdam road, and entered a forest of large and ancient trees, by much the finest which we have seen on the Continent, and evidently several centuries old. Many oaks, elms and beeches were magnificent. Some of the oaks, at two feet from the ground, measured twelve feet in circumference, and had free and clean boles to the height of about forty feet. This wood, in all probability, gave rise to the name of the city ; for *Haag* (the Dutch for Hague) signifies *thicket* or wood. It was originally a seat of the Counts of Holland, and is often to this day called Graaf's Haag, or Earl's Wood.

Although we had no guide, we easily found the palace called the House in the Wood, about two miles distant from the Hague ; and having inquired for the gardener Mr Jacobus Munts, we readily procured access to the Royal Garden. It is kept in good order, and is now arranged in what is here reckoned the English style, the old formal hedges, and fantastically shaped trees, having been in a great measure removed. The grounds are now traversed by serpentine walks, laid with sand : these wind among groves of forest-trees, which have never been subjected to the shears ;

but the flexures are much too regular. Water, as usual, is the only defence or line of separation from the conterminous fields, or from the high road. These ditches, though broad, brimful, and kept tolerably clean, have a dull aspect; but that water should appear stagnant in a flat country, cannot be ascribed as a fault to the gardener. Shrubs and flowers are planted in small compartments cut out in the grassy covering of the lawn. The figures of these compartments are different,—circles, ovals, and crescents. A bed of dahlias was now in flower, but presented nothing uncommon: Indeed, we learned that the collection had been procured from Antwerp only the year before. The plants in the borders and shrubberies were in general of the more common kinds; but some rarities also appeared. Among these the *Passiflora cœrulea* was here displaying its gorgeous flowers in the shrubbery; but we observed that it was contained in a pot sunk in the earth, and not well concealed. *Rosa Pennsylvanica* was very abundant, and seemed not only to be healthy, but to produce its flowers freely, while in Scotland these seldom appear.

Close by the palace is a small greenhouse, erected in 1815 for the Princess of Orange. It contains a few pretty good plants; but there is nothing becoming royalty either in the size of the house or the choice nature of the collection. *Datura arborea* was now in flower, and filled the place with its odour; and the white variety of *Vinca rosea* was in bloom. There are here no hot-houses for the forcing of fruit; nor did there appear to be any thing remarkable among the hardy fruits cultivated in the garden.

This garden at the House in the Wood, is the only one worth visiting at the Hague, with the exception perhaps of Mr Fagel's. The Portland Gardens, belonging to the

Bentincks, though celebrated in former times, are now in a neglected and even ruinous condition.

Scheveling.

Aug. 27.—Early this morning we inquired our way to the Banicre, and walked towards the fishing village of Scheveling, by a grand avenue lined with trees, of which all Dutchmen are justly proud. The length of this avenue is nearly a mile and a half; and it is so straight and so level, that the village church very soon appeared at the termination of the vista next the sea. The tallest and finest trees are Dutch elm, abele, oak, and beech. Many of these are of great size, and have probably seen more than two centuries*. Sycamore, hornbeam, birch, and different species of willow, are occasionally interspersed. There are properly three roads in this noble avenue: a central one for carriages; one for horsemen; and another for foot-passengers. The breadth of the plantation, on each side, is on an average about seventy feet. In some places, the old trees appear to have been cut down; but their places are now supplied by others. Almost all the new-planted trees are white poplars, which are of rapid growth.

We breakfasted in the *Hoff van Holland* inn, the windows of which look out upon the ocean. In addition to the usual repast of coffee and rolls, a countryman of our own, whom we chanced here to meet, had shrimps served to breakfast, which had been shewn to him all alive a few minutes before: by our desire, we had *tong-vischen* or soles, fresh from the sea. While at breakfast, we observed, that

* Le Long, indeed, puts this beyond doubt; for, writing in 1630, he describes this avenue as being then "adorned with fine trees." *Kabinet van Outhaden*, &c. published in 1732.

more than two dozen of small sloops, which we easily recognized to be fishing-busses, were making directly for the low sandy beach, although it was at present a lee-shore, with a considerable surf. The sails were of various hues; Isabella yellow; chocolate brown, and milk white; and this intermixture of colours, set off by the brilliancy of a clear morning sun, increased the picturesque effect. Not a little to our surprize, the crews did not shorten sail, till their barks were just involved among the waves and breakers; and in this odd situation, generally after taking the ground, we saw them deliberately cast anchor. The propriety of the shape given to the hulls of these busses, was now manifest to us; a small British built sloop would have been in danger of breaking up, while they shoved along among the breakers in perfect security. Indeed, that Dutch vessels in general should, of design, be built strong or clumsy, and have their hulks well rounded below, can only appear surprizing to those who have not witnessed the nature of the seas which they have to navigate at home, where they must often take the ground, and where they not unfrequently sail right against the shore. As soon as the anchors were cast, the boatmen, wading up to the middle in the waves, brought out the fish on their shoulders; the sands were covered with persons, of both sexes and of all ages, who began to carry off the cargoes, in broad baskets, on their heads. The principal kinds of fish were Plaice, Turbot, Sole, Skate and Thornback; a very few Cod and Smelts made up the list. It may here be remarked, that the Dutch give the name *Schol* to our plaice; and our sole they call *Tong*, as already mentioned. Their name for the smelt, it may be added, is *Spiering*; which nearly approaches that by which this little fish is distinguished in the Edinburgh market, viz. *Spirling*.

A continuous broad and high bank of sand lines the coast as far as we could see, and forms the powerful protection of this part of Holland, against the inroads of the ocean. Without this provision of Nature, the country would be inundated by every extraordinary tide and gale; for here it may be truly said, "the broad ocean leans against the land." On the sand-hills, the same kind of plants prevail as in similar situations in England; sea-holly and buck-thorn, *Asperago* and *Galium verum*, with sea-marran (*Arundo arenaria*), which last is encouraged here, being found very useful in binding the sand. In some places wheat-straw had been dibbled in, as at Ostend, in order to promote the same object. Considering Scheveling as a fishing-village, we were greatly pleased with it: it was extremely neat and clean, and formed a perfect contrast with our Newhaven and Fisherrow*, the lanes of which are generally encumbered with all sorts of filth. We must confess, too, that in tidiness of dress and urbanity of manners, the fishwomen of Scheveling are equally superior to those of the Scottish villages mentioned.

As we returned to the Hague, numbers of the inhabitants were also on their way to the fish-market, some carrying baskets of fish on their heads, and others employing three or four dogs to convey the fish in small light carts. We had read in books, of these draught dogs being well used, and fat and sleek; but we regret to say, that those which we saw were generally poor half-starved looking animals, bearing no equivocal marks of ill usage. The diligence with which they sped their way to town, with their cargoes, in a sultry day, with tongues lolling to the ground, seemed to entitle them to better treatment.

* Two small towns on the shore of the Frith of Forth near Edinburgh, chiefly inhabited by fishermen and their families.

Fish-market.

We traced the steps of some of our Scheveling companions to the fish-market. As might be expected, the market proved commodious and clean, and well supplied with water. Salmon was pretty common ; carp was plentiful ; and a single John Dory and a single sturgeon appeared on a stall. At some seasons, we believe, sturgeons are abundant, being taken in numbers at the mouths of the Rhine, when about to ascend that river. Four tame storks were stalking up and down in the market. They were in full plumage ; and did not appear to have been pinioned, so as to disable them from flying. Their food consists wholly of the garbage which they pick up about the fish-stalls. A small house, like a dog's kennel, is appropriated to their use ; for the stork seems to be held as sacred by the Dutch as by the Mahomedans.

The Hof.

In returning home we visited a great square of brick buildings called The Hof or Court, being the place where the Assemblies of the States used to be held. In this neighbourhood, a fine sheet of water, called the Vyver, has a refreshing appearance at this warm season of the year. At our own hotel, we were surrounded with palaces ; for the houses of the foreign ambassadors, and of the representatives of the different States, deserve this title. We had a letter from the Right Hon. Sir John Sinclair, recommending us to the notice of Mr Hope, the nephew of the distinguished merchant and banker, who inhabits one of those mansions ; but, unluckily for us, he was at this time absent from the Hague.

From the Hague to Leyden.

At midday we procured a hackney-coach (*huurkoets*,) and removed our baggage to the quay from which the Leyden boats take their departure. We may here take notice of a lesson which we had already learned by experience;— that travellers by the treckschuyts should, if possible, take up their abode near to the quays. The best inns there, are no doubt to be considered as only of the second rate; but, in Holland, these are clean and neat, the people of the house attentive, and the frequenters orderly and quiet. Much time and trouble, otherwise employed in removing baggage, are thus saved. At the Hague, for example, we ought to have lodged at *De zeven Kerke van Rome*, an excellent inn on the quay.

The country through which we passed was flat and monotonous, but upon the whole rich and pleasing. Many smiling villas presented themselves, and the meadows exhibited the most luxuriant vegetation. Dutch butter has long been famed for richness and flavour; and here are situated the rich old pastures, from which the best specimens of that commodity are produced. At a little village called Leydensham, about half way between the Hague and the place of our destination, we had to leave our barge, and enter another, which almost immediately set off; for the Dutch, though slow, are extremely punctual. The banks of the canal continued to be studded with villas, as before: all these are in the same taste: both house and garden are hid by rows and little groves of trees, or by tall evergreen hedges, excepting towards the canal, to which they are always more or less exposed. A raised walk laid with shells often conducts to a kind of summer-house, which projects over the edge of the canal, and frequently has a

door opening to it, thus forming a commodious private pier for embarking in the treckschuyts or landing from them. In general, these possessions are of very limited extent; but a Dutch merchant is perfectly satisfied with such a retreat:

“ A river at his garden’s end,
A terrace-walk, and half a rood
Of land, set out to plant a wood.”

SWIFT.

In little more than two hours and a half we reached the city of

LEYDEN.

At Leyden, we resolved to act on the principle above laid down. Having mustered Dutch enough to inquire of our skipper the name of the best inn near the quay of the Haarlem treckschuyts, he told us, “Den Gouden Angel;” and he was delighted to learn that this was tolerable Scotch. To the Golden Angel we accordingly went, and we had every reason to be satisfied with our choice.

Botanic Garden.

We lost no time in paying a visit to the Botanic Garden, rendered celebrated by its connection with the names of Clusius and Boerhaave. The present superintendant is Mr Jacob Engels: we saw him for a short time, but, notwithstanding his English-like name, we found that he had never been in Britain; and as he scarcely understood French, it was difficult to communicate with him. The extent and general arrangements of the old garden have often been described, and it seems unnecessary to enlarge on them here. It is subdivided by hedges in the formal style; and

ornamented with busts of Linnæus and Clusius *, the latter being, by a patriotic partiality, placed on the right hand of the illustrious Swede. On our remarking to the gardener the propriety of adding a bust of Boerhaave, he admitted it; and this conversation fortunately induced him to conduct us to see some of Boerhaave's plants which were still flourishing in the garden.

One of these deserving particular notice was what our conductor named *Lonicera Tatarica*; which, with us, commonly appears as a shrub four or five feet high, but here forms a small tree. A little way above the ground, the stem measures 2 feet 9 inches in circumference. The trunk bears the evident marks of age, the centre being rotten. What is rather curious, we observed young roots striking into the decayed vegetable matter in the centre,—in the bosom of the tree itself. It now bore many ripe berries, and we were favoured with a few of them †.

Another of Boerhaave's plants was a Flowering-ash (*Fraxinus Ornus*), on a common ash stock, and which, it is reported, was grafted by the Professor himself. As it is now a very remarkable tree, we may be excused for enlarging a little regarding it. The grafting had been made somewhat more than a foot above the ground. If the stock and the graft were nearly adapted to each other originally,

* The inscription in honour of this distinguished botanist is amusing enough :

“ Non potuit plures hic querere Clusius herbas,
Ergo novas campis quaerit in Elysiis.”

But it has a parallel in a compliment paid by the author of the *Gramina Britannica* to the herborizing zeal of the late Mr Sole of Bath : “ If our spirits after their escape from this prison of clay, continue any attachments to what engaged them on earth,”—surely, concludes the amiable author, rapt in botanical fervour,—Sole is now “ simpling in celestial fields !”

† The seedlings which have sprung from these induce us to regard the plant as *L. alpigena*, Lin.

the stock has swelled laterally, or increased in circumference, much more than the graft; and at the same time the tendency to upward expansion being necessarily checked, a protuberant ring has been formed at the grafted part. At the middle of the stock, the circumference of the trunk is no less than eight feet; while the stem of the *Ornus* which springs from it, is only four feet and a-half in circumference.

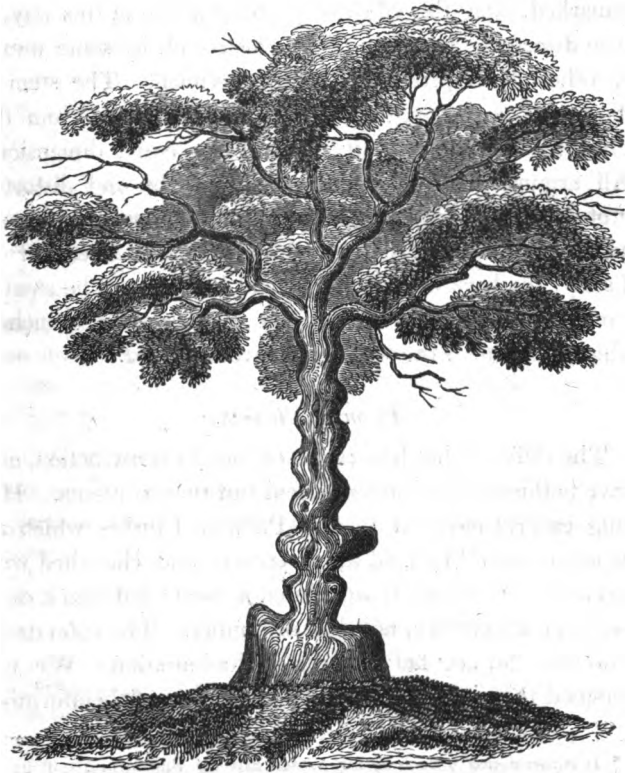

The tree has altogether a very odd and antiquated appearance; as may more readily be conceived from the above sketch, which is taken from Mr Hay's note-book.

The sloping bark at the junction of the stock and graft is quite smooth and complete all around, a fact which would seem to indicate that the stock and graft had originally been nearly adapted to each other in regard to size. Mr Hay, however, seemed to be of opinion, that the stock had originally been considerably larger in dimensions than the graft, and that the cion had probably been placed in the middle of the stock by the mode called peg-grafting; and he remarked, that the effect of grafting a tree in this way, is "to dwarf the top;" an effect which had, by some means or other, been produced in this specimen. The stem of the *Ornus* rises upright nearly twelve feet; and from the stock to the branches, it is of nearly equal dimensions. All around the stem are numerous knobs and distorted protuberances, producing the most singular effect. In no place, however, is there any appearance of canker or disease, the bark being every where healthy. The stem is crowned by a thicket of irregular and crowded branches, which form upon the whole a fine round head.

Palm of Clusius.

The different hot-houses are of the old construction, and have nothing to recommend them but their contents. Having eagerly inquired for the Palm of Clusius, which we expected would be held in reverence, and cherished with care, we were rather disappointed at being led into a dull-looking conservatory, not clear of lumber. The palm itself, however, did not fail to excite our admiration. We understood the plant to have been the *Rhapis flabelliformis* *

* It is mentioned as such by Sir James Edward Smith, in his *Tour on the Continent in 1786*, when writing, it would appear, from memory. The general accuracy of this eminent botanist is so great and so well established,

of botanists, but we found it to be *Chamærops humilis*. The finest specimens of this palm in England do not exceed three feet in height; indeed, Miller describes it as "never rising with an upright stem*." The plant which we now beheld was twenty feet high, including the leaves †;

that it may be proper for us to add, that, with permission of the gardener, we brought home a decaying leaf of Clusius's palm, with its stalk: and that these alone afford sufficient data for ascertaining that we are right in naming the plant *Chamærops humilis*. In the Edinburgh Botanic Garden there are fine specimens of both the palms alluded to. The general characters of each (exclusive of those derived from the fructification) may here be noticed.

The height of the *CHAMÆROPS* varies much according to the age of the plant, and *humilis* is therefore far from being an appropriate trivial name. In Britain it is seen from three to five or even six feet high. The stem resembles the trunk of an arborescent fern, being covered over with decayed remains of the petioles, which give it a rugged appearance. The petioles are stiff, compressed, and armed on each side with a row of short hard spines; at least, these spines are common in the European variety, to which the Clusian Palm belongs; in the West India variety they are rare. The segments of the leaf are folded, entire, and acute.

The *RHAPIS flabelliformis* is seldom, in this country, to be seen above two feet high. The stem is more of a woody nature; or at least, the bases of the petioles being thin, membranous, and closely imbricated, give it, in every stage of growth, a more smooth and woody appearance, than is observable in the *Chamærops*, and several other palms. The segments of the leaves are broader, and of a much livelier shining green, than in the *Chamærops*; they are plaited, and have the margins serrulated; and the apices are not entire, but appear as if torn.

* Gardener's Dictionary, *in loco*.

† It may be remarked, that in the frontispiece to Boerhaave's *Index Plantarum* in Horto Lugduni Batavorum, published in 1710, there is, among other plants, a figure of *Chamærops humilis*, growing in a tub. It seems very likely that Clusius's palm is intended; and if the artist can be supposed to have paid any reasonable attention to the proportional height of the tub and the plant, and if the former be regarded as of the usual dimensions, we must conclude that this fine palm has gained much more than half its present height during the last century. Possibly the escape of the roots

the stem up to the lower leaves, measuring thirteen feet and a half. In the palm-tribe, it is well known, the stem is formed merely by the remains of the petioles of successive circular crowns of leaves; and that these remains form scars, which continue for many years, but which gradually wear off. In this ancient specimen, about four feet and a half of the lower part of the stem are now nearly smooth. At this smooth part, the stem is only a foot and a half in circumference; while, immediately below the leaves, where the remains of the petioles are recent, the circumference of the stem is three feet, or exactly double. The plant is now more than 220 years old; for Clusius undertook the direction of the Leyden Garden in 1592, and continued to manage it till his death in 1609*. It had long continued in a wooden box; but for many years past, it has stood in the natural soil, or the box has been buried in the soil, and gone to decay. We cannot leave this classical plant, without expressing our regret that the house should not be better adapted to its precious inhabitant; in particular, that the light should not be more freely admitted, or have access equally on every side.—We have to add, that the Leyden garden is very rich in this kind of palm; for we were immediately conducted to see another specimen, which is nearly fifteen feet high. This was rendered more interesting, by having produced its spadix of flowers last year

from their confinement in the wooden tub had greatly conduced to the growth of the specimen.

Plate V. contains a representation of Clusius's palm, as it appeared in 1817, the drawing having been made by Mr Greville from rough sketches which we took on the spot. The small palm in the tub close by, is a fac simile of the figure in Boerhaave's *Index Plantarum*, 1710.

* This office, it may be remarked, was in those days considered as on a par with that of our modern professorships of botany; for Clusius was one of the most eminent phytologists of the age, and a distinguished author.

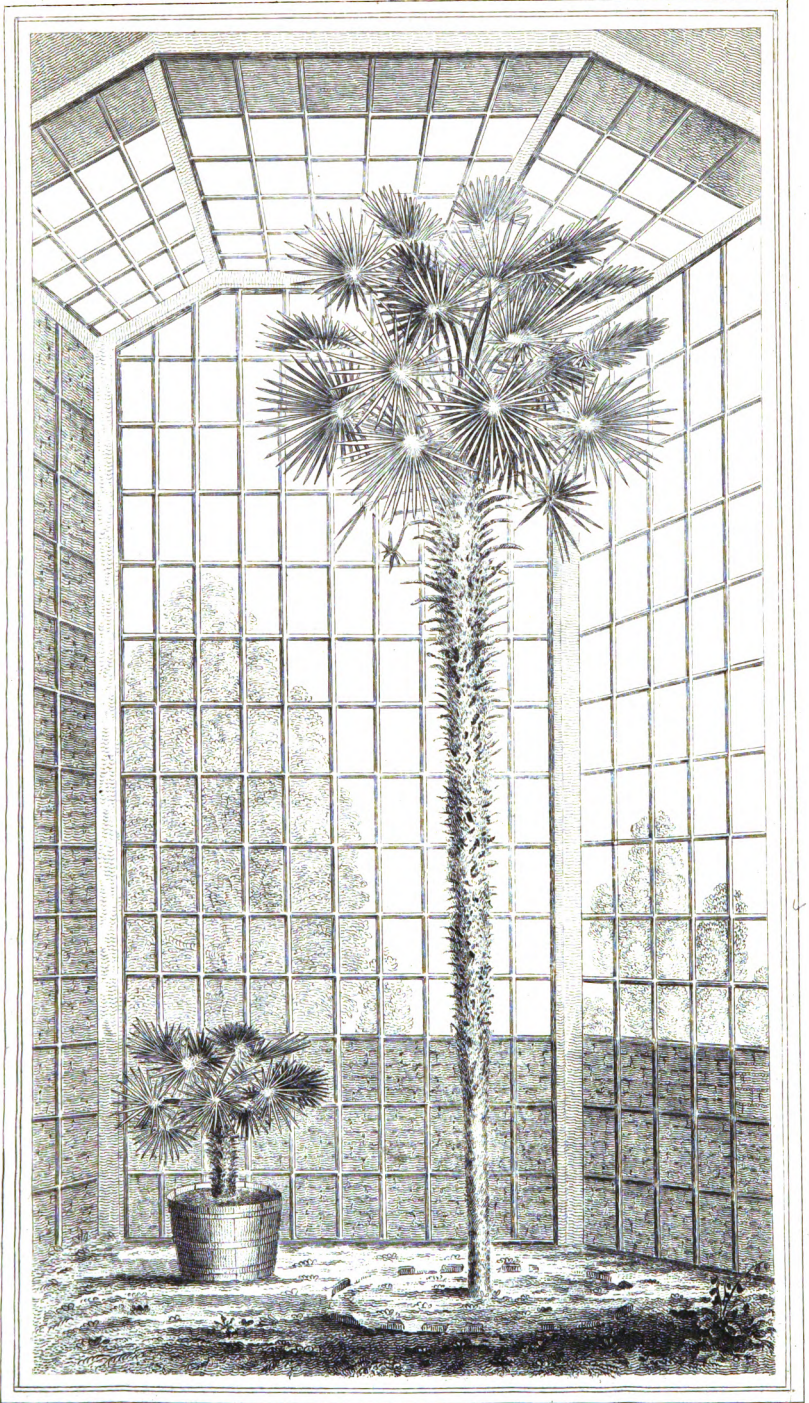

R.K. Grenville del.

Engr'd by W. Lissner.

PALM OF CLUSIUS.

Digitized by Google



(1816). The bunch still remained on the plant, and, as we were told, had not undergone much change in colour or appearance: it seemed to consist exclusively of male flowers.

Last year, also, an American aloe (*Agave Americana*) flowered here; and as this is a rarity in the north of Europe, and more particularly in Scotland, we felt gratified in having an opportunity to see even the dried stalk, about fifteen feet high, remaining on the plant, and still supporting some of the decayed flowers. This specimen of the American aloe is about fifty years old; and it seems probable that it will never entirely recover from the effort of flowering.

Among the green-house plants now set abroad on the sides of the walks, we remarked an African Bladder-nut tree (*Royena lucida*), of large size, and evidently of considerable age. Few of our British specimens exceed six or eight feet in height; but this one, measuring from the bottom of the tub in which it grew, was about sixteen feet high. In another box near by, stood a fine specimen of what the gardener called *Laurus orientalis*, about ten feet in height;—perhaps the Willow-leaved variety of *L. nobilis*?

A strong inclination is shewn in this garden to bring together in one spot and at one view all the plants belonging to a particular tribe, of such as form natural groups. Thus there is a separate semicircular house, or compartment of a house, appropriated to the Aloe tribe; and the collection of these is very considerable. The specimens of Aloe ferox, or Hedge-hog aloe, are particularly large and remarkable in appearance; having been first brought hither from the Cape many years ago. It may be remarked, that a great proportion of the aloe plants are set forth in the open air during the summer months, and that this free exposure

is probably very instrumental in inducing the flowering state. In England, where they are kept constantly under cover, some species scarcely ever shew their flowers. The *Mesembryanthemums* are also placed together, and the collection of these is respectable. What are called Cape Plants are kept in a frame by themselves; but of these the collection is less than we should have expected, considering that the Dutch so long possessed the southern point of Africa. *Pelargoniums*, *Geraniums* and *Erodiums* are assembled on a stage; and we saw them at this time to advantage, many species being in flower. We were much disappointed with the collection of what are called American shrubs; the number of species being not only very limited, but the specimens indifferent. The soil we should, on a slight inspection, have pronounced favourable to their growth, as it consists of a mixture of vegetable earth, not unlike surface peat soil, mixed with fine sand; but it proves too porous and light for *rhododendrons*, *kalmias* and *azaleas*. The botanical *salicetum* is rich, containing no fewer than seventy species of *Salix*.

There is an extensive series of herbaceous plants, chiefly perennial, arranged according to the classes and orders of Linnæus; and the plants used in medicine, or, to speak more correctly, the plants enumerated in the Dutch Pharmacopœia, are grouped in a quarter by themselves.

Great attention is here paid to affording *shade* to the finer and more delicate herbaceous plants. Expressing our surprize at seeing the borders stuck full of common alder twigs, which were now growing luxuriantly, we were told that they were intended for "shading the flowers." We could more readily perceive the utility of shading, where we next saw it practised, in the case of plants kept in pots under glass-frames: here the screens were very neat, con-

sisting of small willow-rods, peeled, and plaited together at instertices of a quarter of an inch. These are laid over the face of the frames; so that the force of the sun's rays is greatly diminished, and only an agreeable broken light reaches the plants below.

Among the less common inhabitants of the open border, a Judas-tree (*Cercis Siliquastrum*) excelled for vigour and size; being trained against the walls of two adjoining houses, rising 25 feet high, and extending about 30 feet along the walls. With no other protection than that afforded by the walls, it produces its flowers every summer; but they were now past. It is evidently a plant of very considerable age.

A Gingko-tree was pointed out to us by our conductor as particularly worthy of notice. It is certainly a few feet taller than the fine specimen already mentioned*, as growing at Mile End Nurseries Near London; the stem is also somewhat thicker, being not less than three feet in circumference, at a foot and a half from the ground. But in regard to handsomeness and shapeliness as a tree, it is much inferior to the English one. Indeed, it had been crowded and overgrown by some ordinary forest-trees; and the gardener seemed to pride himself on its transference, some years ago, to its present situation: there was doubtless merit in safely removing so large a plant; but the choice of its new place is far from being happy, a large common ash here overshadowing it, than which it is not easy to conceive any thing more prejudicial. It yields its flowers every season; but they appear early in the summer.

The only other rare tree which we observed, was the Silver-leaved Almond (*Amygdalus orientalis*). The plant is young, and appears to be grafted on a pear-tree stock.

* Page 9.

Among the herbaceous plants of the borders, the Large-flowered Pimpernel (*Anagallis fruticosa*) held a distinguished place, the flowers being at this season highly ornamental. Many patches of it were now flourishing in the open border; it being, however, a biennial plant, the seedlings had been raised last year, and we have reason to think had passed the winter under glass, and been planted out in the spring of the present year.—Some of the varieties of hollyhock which were scattered up and down the borders, appeared to us both uncommon and beautiful.

In addition to the old garden of Clusius and Boerhaave, which does not greatly exceed two English acres, a new garden, of at least equal extent, is now forming. The site of this supplemental garden is very favourable: it is immediately adjoining to the other; and while it is washed on two sides by a branch of the Rhine, which here makes a fine sweep, it is, at the same time, raised high above the level of the water, a great mass of earth having, in past times, been accumulated here, in the course of fortifying the city. In the planning of this new garden, the style peculiarly denominated *Dutch*, has been entirely departed from; and the English style has been adopted, as far as circumstances would permit. This is judicious enough; the two modes being thus, in some measure, directly contrasted. An extensive Linnean arrangement, we were told, is to be formed in the new garden; and indeed it is already begun: But if the progress made in the two past seasons, afford a test by which to judge of the probable exertions in the future, it will be a good many years before this arrangement be completed, and before the new garden assume its proper appearance. When this happens, the Botanic Garden of Leyden will have few rivals. A very strange sort of substitute for gravel is here employed on the walks: they are laid with a

mixture of peat-moss and tanners-bark, broken so small as to resemble a coarse powder:—but we have to add, that this makes a better substitute for gravel than one would, *à priori*, expect; and if it be overlaid with sand or pounded shells, as may probably be intended, a tolerably firm and good walk may be formed.

In connection with this new garden, a Menagerie is in contemplation. Indeed, we saw several foreign animals, which had lately arrived, and were destined to be the first inmates; particularly an African sheep with four horns, and an American female buffalo with her calf.

Aug. 28.—In the morning, Mr Hay and I prepared a letter, to be dispatched to Dr Duncan *senior*, first Vice-President of the Caledonian Horticultural Society, mentioning the progress we had made in our tour; so that he might, if he thought fit, communicate it to the Society at the anniversary meeting held annually on the second Tuesday of September*.

In the mean time, Mr Macdonald took an extensive walk around Leyden, to reconnoitre the horticultural state of the environs. He reported, that the soil was in general excellent; that market-gardens or *tuins* were numerous, and that large quantities of garden-stuffs were raised in them. In the cultivation of these, there seemed nothing peculiar, except that very rich compost manure was liberally supplied. The specimens of vegetables which he saw, were, upon the whole, inferior to those produced near Bruges and Ghent, though perhaps better than those of Antwerp and Rotterdam. He observed no remarkable

* This, we afterwards learned, was accordingly done, by that eminent physician and zealous horticulturist, at the meeting on 9th September 1817.

varieties of the common fruits. In almost every garden there are some old mulberry-trees, trained to the walls, and very productive of fruit. Even the city wall of defence is in some places clothed with ancient mulberry-trees, planted in the fossé.—On making inquiry, we could not hear of any distinguished private garden in the near neighbourhood, to induce us to prolong our stay at Leyden.

Green-Market.

The vegetable market of this ancient city did not appear to be very well supplied; but we believe that we did not see the supply on the proper market-day. In the Netherlands, we observed that turnips were little esteemed, excepting for feeding cattle: but having been accustomed, at home, to hear Dutch turnips much talked of, as being superior in quality, we now experienced some disappointment; for, not only here, but at Rotterdam and the Hague, all that we have seen have been very indifferent. They seem to be a mixed sort, between the white and the yellow, and without the good properties of either; being of small size, ill shaped, and seldom clean.

University, &c.

We were anxious to take a general, though hasty, survey of a city rendered famous in history, by the siege and cruel blockade of the Spaniards in the end of the 16th century, which the inhabitants, with inimitable constancy, successfully resisted. As a reward for their heroism the *University* was founded, which has since so greatly raised the intellectual character of the people. It was now the time of vacation, and of course neither Professors nor students were likely to be seen; but, during the forenoon, we paid a visit to the buildings of this famed seminary. The external ap-

pearance of these is nowise prepossessing, and the clumsy furniture of the interior carries back the mind to former centuries. These buildings, however, were rendered interesting to us, by the consideration, that from their attic storeys did the Elzevirs, and their successors, for a long tract of years, issue those "Lugdunū Batavorum" editions of classical works, which are to this day highly prized by the learned, and by collectors. But the spirit of the Plantins seems to have vanished from Antwerp, and there is no longer any Elzevir at Leyden. The many ponderous volumes in the Library testified the erudition of former Dutch scholars: in point of fact, the greater part once belonged to Joseph Scaliger. We accidentally met with several of our young countrymen, who were here studying law; for since the English acquired the Cape of Good Hope, where Dutch laws are administered, it is of great importance to young jurists destined for that colony, thus to acquire at once a knowledge of the Batavian code and of the Dutch language.

By the attention of the janitor we procured access to the *Anatomical Theatre and Museum*, situate at a little distance from the College. The Dutch School had the merit of being the first to make fine injections; and here we had the satisfaction of viewing the celebrated preparations of Albinus, many of them still in a high state of preservation.

The remains of the "trophied castle of Hengist," as it has been somewhat poetically styled, or of "the Burgh," as the inhabitants less ostentatiously term it, are seated on a mound near the centre of the city. This has undoubtedly been the work of a remote age. The base of the mound is now planted with shrubs, and with hedges lining narrow spiral walks. It seems unnecessary to enlarge on the other antiquities of the place, of which, indeed, we could only take a superficial glance. It may once for

all be observed, that few of the old buildings of Holland are of more ancient date than the 15th or 16th centuries*. These, though sometimes ruinous enough, having been built of brick, are destitute of that air of grandeur and antiquity which distinguish the remains of our Scottish strongholds of the same period, whose hoary and frowning walls have been constructed of undressed masses of refractory rock.

The Old Rhine passes through the city by various channels or canals, and indeed *is lost* among them. To explain this assertion, it may be remarked, that the several large rivers of Holland may all be traced to the RHINE. When this noble river, after having traversed a great part of Germany, enters the Low Countries, it is divided into a variety of branches; and, by the intersections thus produced, are formed several of those islands which constitute no inconsiderable part of the Dutch territory. At Fort Schenken, the Rhine is first divided into two branches; the largest of which takes the name of the *Waal*, and, turning aside by a winding course to the south-west, falls into the *Maese* above the island of *Bommel*; while the other branch, retaining the name of *Rhine*, proceeds to the north-west. Above *Arnhem*, this last again splits into two; one branch, under the name of *Yssel*, proceeding north, and falling into the *Zuyder Zee*, while the other, retaining the name of *Rhine*, flows westward towards *Utrecht*. Here the unfortunate Rhine is for the third time divided: by much the larger branch, under the name of the *Leck*, joins the *Maese* near *Ysselmonde*, (thus forming a direct navigable communication from the Rhine to *Rotterdam*, most favourable to the commerce of that port); while the proper Rhine, now very greatly di-

* Many of those, in the state in which they appeared in the middle of the 17th century, are neatly represented in *Le Long's Kabinet van Nederlandsche en kleeftsche Outhaden*, 4to.

minished in size, first supplies the canals about Utrecht; and is then (as above remarked) literally lost among the canals of Leyden,—for no part of this once majestic stream enters the sea under the appropriate name of Rhine. To this curious distribution of the waters of this celebrated river at its embouchure, it is not easy to find a parallel: unless, perhaps, the anatomist may here recognise a picture on the great scale, of the ramifications and interweavings of the nerves; while the occasional lake-like expansions may represent ganglions, and the numerous small canals may be likened to plexuses.

The number of bridges over the canals of Leyden, surprises a stranger not a little. They are said to amount to 140, and many of them are built of stone.—The High Street of Leyden has a fine effect, which is 'increased by the curvature of its line. In this respect, as well as in the general aspect of the buildings, it bears no little resemblance to Foregate Street at Worcester. To the praise of this English town, it may be added, that in neatness and cleanliness it is not surpassed by its Dutch rival; and it must be admitted, that the Severn at Worcester is a much finer river than the Rhine at Leyden.

By the side of the Rapenburg Canal, the marks of the devastation produced by a *dreadful explosion*, which took place about ten years ago, are still very evident. A barge passing from the powder-mills near Amsterdam, to the magazine near Delft, with 10,000 lb. of gunpowder on board, blew up: the nearest houses were wholly thrown down by the shock, and the canal was choked up with the rubbish; several hundreds of other houses were shaken and shattered. Of the unfortunate inhabitants, about 130 were killed; and more than double that number were bruised or wounded, by being buried for a time among the

ruins. The Church of St Peter, although at the distance of nearly the eighth of a mile, was considerably injured. King Louis was at the Hague at the moment of the explosion; but he immediately hurried to the scene of distress, and spent the whole of the following night in encouraging the exertions made for the rescue of the sufferers, and the extinguishing of the fires which were constantly breaking out in different points among the ruins. This humane ruler, immediately afterwards, invited many of the houseless families to the royal palace called the House in the Wood, where temporary apartments were fitted up for them, till they could procure habitations of their own. This terrible accident, which happened in the afternoon of 12th January 1807, is yet spoken of with a kind of horror. Many of the houses have been restored; but building goes on very slowly in Holland, and there is still a considerable hiatus to fill up. Improvement, however, has, as usual, resulted; a square has been formed where houses were formerly crowded; and the new streets have been widened.

Leyden to Haarlem.

In the afternoon we left the Golden Angel, and proceeded in the treckschuyt for Haarlem, which has long been celebrated as a favourite seat of Flora. The banks of the canal in the vicinity of the town, presented many villas. These were succeeded by extensive meadows, which are seldom depastured by cattle, the grass being either cut for hay, or mowed in small quantities at a time, and carried fresh to cows which are constantly housed. This is the lowest district of Holland, and could, in a few hours, be wholly laid under water. In one place, we noticed a solitary stork stalking leisurely in a moist meadow; and our skipper made us understand, that a few oyevaarders

generally spend the winter in this neighbourhood. In approaching towards Haarlem, villas again appeared, some of them of considerable size and elegance. In little more than three hours after leaving Leyden, we reached

HAARLEM,

where we took up our abode at the Golden Lion, kept by M. Godthardt, a Frenchman, in Grand Zijlstraat. English strangers, in particular, are here attended by the sons and daughters of the host, who, while they serve with alacrity, join in the conversation, and make themselves the companions of their guests. The evening being fine, we walked out, to take a general view of the town.

Statue of Coster.

We soon came to the statue of Laurence Coster, situate in the market-place, near to the great Cathedral, and opposite to the house in which he first practised the art of printing*. We may here, perhaps, be excused for mentioning, to our credit as presbyterians, gardeners, and printers, that while we had passed scores of Madonnas in Austrian Flanders without a single reverence, we had all, by a simultaneous impulse, lifted our hats to the palm of Chu-

* Mandelslo, in his Travels, says that Coster made letters of beech-wood about the year 1420; but this is probably twenty years too early. The oldest specimen of his printing now in existence, consists of the Lord's Prayer and Creed in Latin: the impression is taken only on one side of the paper, and from wooden types. This specimen is preserved by the Magistrates of Haarlem, and the date assigned to it is 1440. Moveable metallic types were first employed at Mentz, soon after that period. More than half a century elapsed before the art of printing was introduced at Edinburgh, by Chepman, under the patronage of James IV.

sius, and now did so to the statue of Laurence Coster. This sort of ceremony in a public place, might have brought ridicule upon us any where else; but here there is such a continual doffing of the hat to all ladies, known or unknown, and to all strangers, that we could pay our devoirs at the shrine of this Dutch Inventor of the Art of Printing, without incurring that risk. As a piece of sculpture the statue has no merit. It formerly stood, we are told, in the Botanic Garden; and we do not wonder that the Professor of Botany did not object to the transference of this ornament to the market-place.

Haarlem has, at one time, been fortified with a strong and high brick wall; but this wall now bore testimony to a long continued state of peace; for its exterior was, in many places, covered with large fruit-trees, neatly trained against it, and which presented crops of apples, pears, plums and mulberries. A narrow strip of ground, too, that lies between the base of the wall and the fossé, was occupied every where with crops of kitchen vegetables, intermixed with patches of showy flowers.

Bloemistries.

Aug. 29.—Haarlem has long been noted for its *bloemistries* or flower-gardens, and particularly for the success with which hyacinths and tulips have been cultivated in these. The only season for seeing these bulbous-rooted plants in flower, is the end of April and beginning of May. We resolved, however, to visit several of the gardens; flattering ourselves, that we might not only see the kind of soil preferred, but also perhaps witness the mode of planting; and it was impossible for us to imagine, that florists, who excelled not only in tulips and hyacinths, but in polyanthus-narcissus, the iris tribe, in anemones and ranunculuses, should

not possess other ornamental plants deserving of attention. We therefore set out, with raised expectations, to examine some of these gardens.

Van Eedens.

The name of Van Eeden having been noted, for more than a hundred years past, in this line of horticulture, we naturally began by inquiring for Van Eeden's bloemistry. We soon discovered that there were no fewer than four of the name, all descendants, we believe, of a common ancestor who had acquired fame as a florist, and all possessing gardens in the neighbourhood of each other. These are situate to the south of the town, on the other side of the Sparen, a small river which flows partly through Haarlem, and partly on the outside of it, under the fortifications. We entered the garden of Mynheer Matthew Van Eeden, over the door of which was inscribed *Hof van Flora*. Making full allowance for the unpropitious season of our visit, we certainly felt some little disappointment. The Garden of Flora occupies, we are persuaded, little more than a quarter of an English acre. This small piece of ground receives all Mr M. Van Eeden's fine bulbs; and as the time of planting had not arrived, it was lying in a state of careless waste. We could not help thinking, that the sign-board should be displayed only during the months of April and May, and should be removed when the bulbs have done flowering; for there is no room for the cultivation of any of the other delicacies of Flora, which might maintain a show during the summer and autumn months. Mr Matthew Van Eeden may probably possess a separate nursery for young bulbs, but he did not mention it to us. His nursery of fruit-trees, he informed us, lay at the distance of five or six miles from town.

The best double hyacinths are planted in a bed by themselves, calculated to contain about 1000 bulbs. This space, we were told, is covered with an awning while the plants are in flower. A new soil is prepared for such beds every year. We saw a small quantity of compost in a state of preparation: the manure introduced must have been very well rotted, for the compost very nearly resembled the natural soil, which is a rich light loam, mixed with vegetable earth, and a very considerable proportion of pure white sand. Moisture can scarcely lodge on such a soil; yet the beds for the choice bulbs, both hyacinths and tulips, are raised several inches above the natural soil.

The flower-roots are at this season kept in a ware-room or out-house, in large shallow drawers or cases, so contrived that the air circulates around them. Matthew Van Eeden's collection appeared to us considerable; but it was the first we had seen.

He shewed us drawings of two very large and fine specimens of hyacinths, produced in his garden some years ago. In the high-sounding and complimentary nomenclature adopted by florists, both Dutch and English, the one was called Grand Duke Constantine, and the other Gloria Mundi. The colour of the flower of the former was white and rosy; of the latter, blue. In each, the stem was fully sixteen inches in height, and blossoms covered the upper half of that space. The blossoms were large, most symmetrically campanulate, and hanging horizontally like the carillon-bells in a tapering steeple, a single blossom forming the apex. The leaves were nearly as tall as the flower-stem. In vigour and in beauty, these specimens certainly appear to have surpassed any ever seen in Scotland.

The flower-garden of Mr H. Van Eeden and Co. is larger than that which we had more particularly examined.

The collection, again, of Widow Van Eeden and Son is but small. The most extensive collection is doubtless that of Mr ARIE CORNELIS VAN EEDEN. We have much reason to regret that we did not meet with this gentleman; for we afterwards received, from good authority, the strongest testimony to his merit as a cultivator, and also to his general intelligence regarding every thing connected with the gardening of Holland. To make some amends, however, we have since established a correspondence with this excellent horticulturist.

The Palace Garden.

We next visited the gardens of the Palace of Haarlem. This was formerly the country house of Mr Hope, the eminent banker and merchant, and was built by him at a vast expence. When the French took possession of Holland, this was by much the most elegant residence in the country: and it did not fail to attract the eyes of Louis Buonaparte, who, upon his elevation to the regal dignity, discovered immoderate fondness for splendid mansions. The royal wish to purchase was signified in such a way to the respectable owner, that to have refused would have been pretty evidently equivalent to losing all. The price was therefore left to the generosity of the King, and his Majesty tendered 120,000 florins (L. 10,000 Sterling), a sum not equal to the prime-cost of the materials! It has in this way come into the hands of the present King of the Netherlands, and its possessor at this time was the Dowager-Princess of Orange. We could wish to have added, that full indemnification had since been made to the original owner; but this has not hitherto been done. The front of the house has a very light and elegant appearance, and

the proximity of the Wood of Haarlem greatly increases its beauty, and produces a charming effect.

In Mr Hope's time, the garden was very confined and incomplete. Louis had the merit of adding a new garden, communicating with the former by means of an arch thrown over the high-road, which passes near the house. This additional garden is skirted by a broad piece of water, abounding with fish. From a summer-house here, raised only three or four feet above the level of the water, we could descry the steeples of Amsterdam,—so uniformly flat is the intervening country. On a small branch or canal communicating with the lake, a bathing-house, with all its conveniences, is situate.

The collection of plants in this garden was never, we believe, considerable; at present, it is very scanty, the old lady having no taste for botany. The pots containing the greenhouse plants were sunk in the earth along the sides of the walks, to keep them from being upset by the wind, or from being overparched by drought, in case of regular watering being neglected. They were of the most common kinds, and generally poor specimens.

We had the satisfaction, however, to find, that more attention is paid to the raising of fruit of different kinds.

Apricots are not commonly *forced* with us; but here we saw a small glazed house, containing apricot-trees which had this year been forced. There was a narrow back-flue for fire-heat; but the principal dependence for increased temperature was evidently placed on the heat arising from the fermentation of tanners-bark and horse-dung, in front-pits. Our conductor, one of the gardeners, informed us, that, in the end of April and beginning of May last, no fewer than 250 ripe apricots were gathered from one small tree which he pointed out to us. As, however, this fruit, after being

fairly *set* or formed, requires five or six months to swell and arrive at maturity, and as the new wood for next season is not at present (29th August) nearly ripe, this statement must doubtless be received with some qualification. The same tree, we understand, is to be again forced next spring; but it certainly cannot then be expected to produce a third part of the number mentioned. The principal produce of the apricot-tree, as is well known, is from the new wood; but some flower-buds generally appear on the older spurs; and on these last must next year's precarious crop depend.

Raspberries are here *forced*, in the mode practised with vines at the Baron de Vroeylande's near Ghent*. The bushes are planted on the north and south sides of a pit, filled with tanners-bark, leaves, or stable-litter. The shoots of last year were at this time laid down to a horizontal trellis, where they had yielded fruit in the vernal months. All means of artificial heat were now, of course, removed. The shoots of this year were allowed to spring upright; and these will, in their turn, be laid down to the trellis at the approach of winter, when the others will be cut away. The gardener told us, that raspberry plants thus treated yield large crops; and doubtless they are much better adapted for *this* mode of forcing than vines. We do not recollect to have observed this plan of procuring early raspberries practised in our own country. Where the fruit is relished by the family, it may probably be deserving of a trial in private gardens; and where, as at Covent-Garden, it is likely that the prices procured would reward the expence and trouble bestowed, it might even be worth the attention of the market-gardener.

* *Suprà*, page 62.

The *peach-houses* are so contrived as to be capable of being divided lengthwise at pleasure, by means of a wooden partition; so that grape-vines in front can have heat applied to them, while the peach-trees behind remain exposed to the atmosphere. But, in other respects, the houses are not well constructed. There are pits for tanners-bark immediately in front of the peach-trees, which must unavoidably bury the roots, and, by cramping their pasturage, deny the trees suitable nourishment. This mode of construction we have already condemned, when speaking of the Baron de Vroeylande's garden, (page 63.) The general soil of this part of Holland is certainly not favourable to peach-trees. We observed them languishing in the open borders, trained against the walls; and in this house, sufficient pains had not perhaps been taken to prepare a compost for the plants. They appeared sickly and foul, and not likely to yield much fine fruit.

There were several *amanas* pits, well filled with plants, in good condition. Indeed, we have not hitherto seen pine-apples so well cultivated on the Continent.

Some standard *apple-trees* were loaded with fruit. One large tree attracted particular notice, on account of the bright red colour of the apples; it proved to be the Autumn Calville. Another tree, with fruit of a rich glossy appearance, engaged our attention: it was of a variety with which we were unacquainted: the gardener called it the Zydehemd or Jerusalem-apple, and assured us that it is esteemed at Haarlem. We found another apple, however, to be also called "the Jerusalem;" one nearly allied to the *Passe-pomme rouge* of the French.

The *pleasure-grounds* are pretty extensive. They contain numerous clumps of shrubs, and groups of perennial herbaceous plants, and also of annual flowers. In one place is a small Chinese pavilion, perfectly circular, with a

conical thatched roof, supported entirely by a single upright post in the centre: it is a mere garden *parapluie* for shunning a shower; at a little distance, no exertion of fancy is requisite to find in it a striking resemblance to some gigantic species of mushroom, the centre post representing the stipes, and the circular thatched roof the pileus. Exterior to the pleasure-grounds, several noble avenues of trees, connected with the Wood of Haarlem, and the public roads passing through it, blend and harmonise with them, thus tending greatly to increase the ornament of the place.

The neighbourhood of Haarlem has long been noted for the production of excellent kitchen-garden *seeds*. At present, however, these are chiefly raised by market-gardeners and small farmers at some little distance from the town; and, as far as we could learn, no very particular precautions are taken to prevent the intermixture of varieties, by the blossoms of one kind being contaminated by the pollen of another. For a number of years past, Haarlem has been more distinguished for its flower-nurseries.

Kreps and Company.

Leaving the Palace grounds, we paid a visit to Messrs Kreps and Company, whose bloemistry is in the neighbourhood. At their warehouse we saw a more extensive collection of flower-roots than we had seen in the morning. At this season the bulbs are here kept in an apartment lined with wood, in the midst of which is a stage, containing a number of moveable shelves, open in front. On these the flower-roots are laid, loosely or not heaped on each other, and the sub-varieties are separated merely by squared rods of wood. While the tendency to dampness is restrained by means of the timber lining, air is permitted to circu-

late freely around the bulbs. Immediately beside their warehouse, Messrs Kreps possess about a Flemish arpent or Dutch acre * of ground (apparently equal to two acres of our measure), where their choice bulbous-rooted plants are cultivated. At this season, the garden presented chiefly a number of empty flower-beds; an appearance of desolation, however, which is here lessened, by means of the exterior side-borders being filled with ornamental herbaceous plants. We remarked of Messrs Kreps, that they shewed no kind of jealous reserve, (some symptoms of which we had elsewhere encountered), but frankly answered every question we put to them. They presented us with a copy of a small pamphlet, containing an account of their method of cultivating hyacinths: this they had prepared chiefly for the benefit of their English correspondents, many of whom had complained of want of success in this branch of culture. This little tract, so valuable to the florist, we have reprinted in the Appendix, No. II.

Their collection of *hyacinths* seemed to be very ample. The flowering bulbs are planted in five large beds, placed in front of a greenhouse. Three of these beds consist wholly of double and multiplicate flowers; the fourth contains early

* Mr Hay having compared his English foot-rule with Mr Kreps's Dutch one, found that the English square foot is to the Dutch as 144 is to 163.140. Therefore 12 such feet squared = 163.140. This multiplied by 600, = 91884 square English feet, in the Dutch acre. The Scots acre, by the customary measure (the English foot), contains 54760 square feet, and is therefore less than the Dutch by 37124 square feet. If recourse be had to the Scots foot, (as fixed in Art. Geometry, Encyc. Brit.), the Scots acre will contain $55353\frac{6}{10}$, and the Dutch will exceed it by $36530\frac{4}{10}$ square English feet. As the English acre contains 43560 square English feet, and the Dutch, as above mentioned, 91884, the latter is larger than two English acres by 4764 square feet.

flowering varieties; and the fifth, single flowers, with the bells or blossoms of the finest colours and shapes, and of the largest size. In ordinary seasons, they told us, the hyacinths are in full glory between the 20th and 30th of April; and we have no doubt, that the effect must be as brilliant, and the fragrance as delightful, as Messrs Kreps emphatically described. These beds are four feet wide, and of considerable length. They are raised more than half a foot above the natural surface of the soil. The sides and ends are supported by deal-boards, an inch and a half thick, and nine inches deep. These marginal boards are placed on the surface of the natural soil, and alleys, about three feet wide, are left between the beds. The prepared soil for these beds is renewed annually. After the bulbs are lifted in summer, the compost in which they grew is removed, to the depth of the boards or a little more, and the subsoil is dugged over: a new layer of compost of equal depth is afterwards introduced; and in this, the choice bulbs are again planted in the autumn. The compost consists of pure white sand, rotted leaves of trees, fine peat-earth, and a small proportion of thoroughly rotted cow-dung; the whole very well intermixed and reduced, by being often turned over. The natural soil, it is to be remarked, is here well adapted for receiving the extreme fibres of the roots; otherwise a deeper layer of compost would be required.

Tulips are treated much in the same way; but for them a more tenacious soil is desirable. Kreps and Company have also a valuable collection of these: but hyacinths require and receive more attention, and are in higher estimation with Dutch florists at present, than tulips.

Besides hyacinths and tulips, ranunculuses and anemones, together with other showy plants that have either bulbous or tuberous roots, are cultivated, and propagated for

sale, by the Haarlem bloemists. In this garden there was likewise a collection of Auriculas and Polyanthuses, in pots; but, instead of being kept in a wooden frame, as is practised by British florists, the pots were plunged in the open border, and every three or four rows divided by screens of reed, about four feet high, which thus served both for shade and shelter. They were protected from heavy rains, we understood, merely by bass-mats thrown over these screens. In the cultivation of Auriculas and Polyanthuses, the Dutch bloemists are certainly left far in the back-ground by the zealous florists of Lancashire and Cheshire, especially near the great manufacturing towns of Manchester and Macclesfield.

In the greenhouse, Mr Kreps *senior* shewed us the *Aytonia Capensis* in flower; and we were delighted to hear him boast that it was named after his "old friend, Ayton of Kew!"

We inquired for the double-flowered Orange-lily (*Lilium aurantiacum*, fl. pl.) which we had seen announced in a Haarlem catalogue. Mr Kreps mentioned, that he had procured it many years ago from a florist near Rotterdam, curious in collecting all sorts of rarities, variations, or monstrosities, in the flower-tribe. For the first year the flower was double; next season, however, it became single. The plant having, on this account, been neglected, was suffered to remain unnoticed in a spare side-border, till even its very existence had been forgotten, when, after a lapse of several years, having renovated its vigour, it again attracted notice by its flowers appearing in the double state. It degenerated a second time, and was then finally lost sight of.—We had heard that the Dutch florists possessed some *varieties* of the Mexican Tiger-flower (*Triglochin Pannonica*); but we were now assured that none such had ever been seen at Haarlem.

Being aware that Dutch nurserymen sometimes talk of furnishing three hundred varieties of *Roses*, we were desirous of viewing these in the nursery lines. We found the collection here to be very considerable; and Mr Kreps mentioned, that he had procured all the known sorts cultivated in Holland, and many from England; but he candidly added, that he could not, in fairness, engage to furnish more than about *one* hundred distinct varieties. We may add, that, as far as we could learn, the new varieties of native Scots roses, as well as of garden roses, raised by Messrs Brown at Perth and Mr Austin at Glasgow, excel, in delicacy of appearance, all the more recent productions of the florist in this department of the art, either at Haarlem or in any other part of the Low Countries. These have been procured by sowing seeds of semi-double varieties of the little Scots rose (*Rosa spinosissima*), and seeds from the hips which frequently follow multiply flowers of *Rosa alba*, *gallica* and *centifolia* *.

We may here remark, that we had, with some regret, passed the village of *Noordwyck*, situate near the sand-hills on our left, in the way from Leyden; for this, we were told, is the most celebrated spot in Holland for the cultivation of roses. But we now learned, that the rose-gardens of *Noordwyck* are distinguished for their extent chiefly, and not for the number of varieties of rose-tree cultivated. The great object of the cultivators is the collecting of the petals of the flowers, to be used in perfumery and in medicine. A profuse bloom of roses is therefore much more desirable to them than fine colours or regular shapes. In point of fact, only three or four kinds are in general cultivation. These are chiefly *varieties* of two of the *species* of rose-tree above mentioned: One variety, which we call the

* See Appendix, No. III.

Dutch Hundred-leaved Rose, is regarded as belonging to the *Rosa Gallica*; another is our common Cabbage-rose, a third what we style the Dutch Provins, and these last are considered, by Mr Lindley, as having sprung from *R. centifolia*. A friend who visited the place has informed us, that the flowers are sent annually in great quantities to Amsterdam, and that they are thence exported even to Constantinople, where they are used by the Turks for making rose-water. There are three extensive rose cultivators at Noordwyck; but the most distinguished is Mr Cornelis Stegerhoek, who has, during the greater part of a long life, been engaged in this pleasing branch of rural economy,—reminding one of the Garden of Roses and its owner, described in the Teutonic poetry of the Middle Ages:

“ For two and thirty years he has graithed a spacious mead,
And a garden fair has planted all with the roses red *.”

Mr Stegerhoek has in his time raised many seedling rose-trees, and has selected from among them several which were remarkable for the variegation, beauty, or fulness of the flowers. These he at different times communicated to Messrs Leo and Kennedy of Hammersmith. One of his latest and finest varieties he has named *Rose de la Belle Alliance*,—a name more likely to be attractive at London than at Paris.

The principal tree nursery-grounds of Kreps and Company are situate on the other side of the Haarlem Meer; but they have a collection of fruit and forest-trees, at a short distance from town, and one of the partners obligingly offered to conduct us thither the next day. In their bloemistry, however, we saw several fine plants, both in pots and in the open border, of an extremely dwarfish va-

* Weber's "Book of Heroes."

riety of the common apple (as we presume), which retains its leaves and fruit till midwinter, or longer, if it be protected from frost. It here receives the name of *Pyrus sempervirens*, or Bastard Rennet; and we learned that pots containing the tree, clothed with its leaves and fruit, have, at great dinners, been placed on the table in the months of January and February. Dwarfish fruit-trees, of different kinds, are much in repute in Holland; and we may mention, that a physician and zealous amateur-horticulturist at Ems, in Hesse-Darmstadt, has published a work entitled *Obst-Orangerie*, in which he extols them, and has thus spread a taste for them in that part of Germany. He is himself, we are told, very successful in this sort of culture, having trees of the most diminutive size bearing plentifully; the more tender kinds in flower-pots and tubs, so as to be protected, when necessary, by being placed in the greenhouse or orangery.

Eldering's Bulb-Nursery.

In the afternoon, we took a walk, in the opposite direction from Haarlem, towards the sand-hills near the sea, in quest of the nurseries of Mr Gerret Eldering, to whom we had a letter of introduction from one of his Edinburgh correspondents. On the road-side, Field Southernwood (*Artemisia campestris*), which is a rare plant in England, and does not at all occur in Scotland, appeared as a common weed. After passing a pleasant hamlet, sheltered by these sand-hills, we came to an extensive bleachfield; and this proved to be Mr Eldering's, for he unites the professions of bulb-cultivator and bleacher. The bleachfield is in the lowest part of the ground. In our own country we should have expected the ditches, in such a situation, to have been dirty and slimy; here, however, they were free from im-

purities, and the water was of the most limpid transparency. A great deal of extremely fine thread was now bleaching; but Mr Eldering did not conceal from us, that, notwithstanding the celebrated whitening property of Haarlem water, he experienced the greatest advantage from employing chemical means (oxymuriatic acid) in destroying the vegetable colour.

All around the little village of Overveen, the soil is admirably adapted to the raising of bulbous-rooted plants, consisting of a light vegetable mould resting on fine sand; and in this favourable situation, we now found, have been established the most extensive bulb-nurseries. Above a hundred English acres, Mr Eldering thinks, are in this neighbourhood occupied in producing the different kinds of bulbous and tuberous flower-roots. All of these, it is to be understood, require nursing for several successive years, some of them for not less than six or seven, before they become ready for the market. The gardens of the florists on the south side of Haarlem are chiefly for show, and contain only bulbs which have attained maturity, or are in a flowering condition. These florists frequently purchase supplies of bulbs from the growers at Overveen. The most extensive cultivators are Messrs Veen and Co., and Mr Eldering. The latter was at this time engaged in packing a very large case of bulbs for England; and he told us, that he had already dispatched about thirty similar cases, many of them for the same country. Notwithstanding the great inroad thus made on his stock, his collection is so ample, that he estimated the flowering-roots (chiefly hyacinth, tulip, and polyanthus-narcissus) still on hand, and of which he could dispose, without depriving himself of a sufficient store of breeders, as probably not fewer in number than 50,000.

He very obligingly offered to walk with us through part of his nursery-grounds; and as he was not only well informed in this branch of Dutch horticulture, but spoke English fluently, we found him, in more respects than one, an interesting acquaintance. He had begun replanting his bulbs about a week before; and we observed that the polyanthus-narcissus is the first committed to the ground. We saw several workmen engaged in this operation. The bulbs are brought to the field in large wheel-barrow. They are planted in beds, between four and five feet broad, and of great length. The surface-soil, to the depth of six or seven inches, is taken off the first bed, and removed to the neighbourhood of the last one, in the compartment to be planted. The bulbs being placed in cross rows on the beds, are arranged merely by guess of the eye, and slightly pressed into the soil with the fingers. The surface-earth of the next bed is then thrown as equally as possible over the bulbs;—and this process is repeated, till all the beds be filled. This mode is evidently much superior to planting with any sort of dibble: it is not only much more expeditious, but all risk of leaving hollows below or around the bulbs is effectually avoided. Twelve persons, men and boys, were engaged in planting; and although they have begun thus early, Mr Elderling signified, that he would be glad to find that all his roots were safely lodged in the ground, by the middle, or even the end of November. He has more than twenty English acres occupied with the culture of flower-bulbs of different kinds, in various stages of progress. But it is to be observed, that all these twenty acres are not, at one and the same time, employed in this sort of cultivation. On the contrary, the places in which the finer flowering hyacinths and tulips are planted, are here changed every year; crops of various cu-

linary vegetables being taken for two or three years in succession after the bulbs, and manure (almost always from the cow-house) added, as judged necessary, along with these grosser feeding plants. We noticed rows of very luxuriant pease and beans, now nearly past. It thus happens, that, for every acre of choice bulbs, not fewer than five or six acres of ground must be continually in a state of preparation; and in this way, a very fine, rich, and yet light soil is gradually prepared for receiving the hyacinth and tulip bulbs. The Crocuses, flowering very early, and soon perfecting their new bulbs, a good crop of potatoes is often raised, the same season, on the ground from which they are removed. For the beds destined for the finest hyacinth bulbs, a compost is here prepared, much in the same way as at Mr Kreps's. The natural vegetable earth of the country receives an additional proportion of fine white sand, sometimes collected from ruts on the by-roads, or from the margins of ditches; and rotten tree-leaves, particularly oak-leaves, and well decomposed cow-dung, which has lain in store not less than two years, are added in equal quantities. Sometimes, but not very often, a small proportion of old tanners'-bark, such as comes from an exhausted hot-bed, is likewise introduced.

Shelter from high winds is indispensable, not only to the perfect development of the flower of bulbous plants, but to the vigour of the bulbs themselves. All the compartments of this nursery are therefore carefully inclosed, with hedges and screens of different kinds. If the leaves be twisted or broken by the winds, especially in the early period of their growth, the plants experience a severe and lasting check. A very fine and strong flower may, by having its leaves torn or destroyed, become, in a single season, so greatly weakened and deteriorated, as scarcely to

be recognized; and it seldom completely recovers for several successive seasons.

The hyacinth nursery-ground here, extends every year to about 600 square roods, Dutch measure. The rood, it will be remembered, is 144 square feet, and the Dutch foot $\frac{7}{8}$ ths of an inch longer than the English *. Some varieties of the hyacinths are not readily propagated, and on this account, continue rare and high-priced. A simple expedient is, in such cases, sometimes resorted to: the base of the bulb is slightly cut or notched in three or four places; this hinders the plant from exhausting itself in the production of a flower-stem, and at the same time induces a tendency in the bulb to throw out offsets at the wounded places; which offsets soon become independent plants.

Mr Eldering appropriates several beds to the raising of various bulbous-rooted plants from the seed. This sort of cultivation requires great patience and perseverance, and seems better adapted to the character of the Dutch than of the British horticulturist. In general, in raising hyacinths and tulips from the seed, if half a dozen of plants, worthy of preservation, be procured out of each thousand seedlings, after the labour and watching of several years, it is considered tolerably good success.

We had some conversation with this intelligent person, relative both to the sand-hills and the subsoil of this part of Holland. He informed us, that from the range of hillocks in the neighbourhood of his nurseries, much sand has, in the course of the last twenty years, been carried away for building, some of it to a great distance, the numerous canals affording the means of conveyance at very easy rates. Below the pure sand thus removed, a vegetable soil occurs, on a level with the general surface of the country, indicating,

* *Suprà*, page 176. Note.

that the elevation has arisen merely from sand-floods. Mr Eldering has sunk various wells about his bleaching grounds, and has had other opportunities of ascertaining the successive strata downwards. It has been already noticed, that beneath the light vegetable mould, which is mixed with fine sand, a bed of nearly pure sand occurs. This stratum of sand seldom exceeds a foot in depth; but it operates as a beneficial drain, and without such a provision of nature, the soil of this part of Holland would have been in a great measure incapable of yielding those fine productions of Flora and Chloris for which it is remarkable. In a country apparently immersed in water, the delicate bulbous roots of hyacinths thus find a kindly soil, free from injurious stagnant moisture. It is well known, that most culinary plants are injured by the application of too much water, as they lose in flavour as much as they gain in luxuriance. The open cineritious soil of Naples requires constant supplies of water, by artificial means; and the vegetables there produced are said to be comparatively insipid. Here, by the economy of nature, the porosity of the soil is so admirably adapted to the humidity of the climate, and the superabundance of water in the surrounding ditches and canals, that kitchen vegetables, in general, are not deficient in good qualities. We may take this opportunity of remarking, that, in a dry climate, cabbage plants are not only not injured, but really improved, by copious watering over head, even during winter. Mr Meason of Lindertis informs us, that, in the south of France, near Lyons, in the middle of the month of November, he found the people in a garden watering Savoy cabbages profusely,—throwing a whole pottfull of water upon each plant. They told him, that this operation is frequently repeated while the weather is dry; and that, in this way, they keep their Savoys quite green and fresh during the whole winter.

Under the stratum of sand is found a bed of peat-moss, generally about six feet in thickness: this peat-moss seems to be composed rather of leaves and stems of reedy plants, than of heath or the plants which accompany heath; and fragments of large branches, and even trunks of trees, have sometimes been discovered in it. Beneath the peat, a thin bed of blue clay commonly appears: this layer of clay is usually about a foot in thickness; but Mr Eldering has observed it, in some places, only a few inches thick, and it seems in other places to be altogether wanting. In this blue clay are many marks of vegetable remains, such as leaves and bark of trees. Below the clay, again, occurs an "ugly red sort of mixed stuff," no specimen of which we could at this time see, and through which the workmen had never penetrated.

Voorhelm's Nurseries.

Aug. 30.—We next morning visited the flower-garden and nurseries of Mynheer Voorhelm, a name usually associated by English tourists, who have visited Haarlem, with that of Van Eeden, and equally celebrated for a hundred years past, the present florist being the grandson of him who is so often mentioned in Justice's "Scots Gardener,"—an excellent and original work, published at Edinburgh about the middle of the last century.

We found Mr Voorhelm's collection of bulbs to be very considerable; but not superior to some others in the immediate neighbourhood. Among the greatest rarities in his garden were seedling plants of the Stone Pine-tree, (*Pinus Pinea*), raised from large cones which he had procured from Italy, where the kernels are often served up in the dessert: the stone-pine, it must be understood, is really an uncommon plant in Holland. We observed a pear-tree,

bearing abundance of fine fruit, not of an appearance familiar to us: Mr Voorhelm called it the *Wygen-pear*, and recommended it as an excellent table fruit, for the months of September and October.

Moonen's Garden.

We afterwards made a call at the garden of Mr Jean Moonen, in the Kleine Hautweg. His collection of bulbous-rooted flowers is not very large: but he excels in possessing a great variety of exotic herbaceous plants, some of them curious and rare, which he keeps, during winter, in a greenhouse, and in several sunk frames. He shewed us, with no little triumph, several plants which he had procured from Lee and Kennedy at Hammersmith, and Loddiges at Hackney; for both here and in Flanders, these eminent English cultivators are looked up to, as the first in the world in that department of horticultural trade.

Van Marum's Museum.

Mr Kreps having kindly provided us with a card of admission to the Museum of Dr Van Marum, we repaired thither at midday, the time appointed. The greater part of the Doctor's house is fitted up as a Museum, different rooms containing quadrupeds, birds, fishes, shells and corals, arranged chiefly in the Linnean order. The Argus Pheasant (*Phasianus Argus*) is peculiarly fine. The specimens of this splendid bird are generally mutilated, or deprived of their feet, before they leave China: this one, however, is quite perfect. It is provided with a large glass cover, and is set in the middle of the floor, so that it may be viewed in every direction. The collection is very carefully kept; damp being prevented by means of stoves, and those specimens possessed of bright colours

being kept secluded from the light. Though many of the stuffed quadrupeds and birds were prepared more than thirty years ago; yet, by this sort of attention, they are still in good preservation.

Dr Van Marum has directed his attention to every branch of natural history. His garden and conservatory, also arranged after the Linnæan method, are highly deserving of notice and commendation. The Doctor, we were assured, is particularly attentive to strangers, and obligingly communicative; but at this time he was unfortunately from home. The superintendant of his garden, Mr Frederick Bekker, is well skilled in his department; and we may here remark, that he undertakes to furnish rare plants from a separate establishment belonging to his brother and himself.

Teylerian Museum.

We next visited the Teylerian Museum, of which Dr Van Marum is at present chief director. Pieter Teyler of Huilst lived, we believe, almost in the style of a miser, but left vast riches; and these have, by his will, been expended in purchasing a magnificent collection of philosophical instruments, a suite of specimens of minerals, and a library of books on natural history. A large hall has also been built for the reception of these treasures. This hall is excellently well lighted, by means of windows placed along the sides, near the roof. The building bears the date 1780. A very large and powerful electrical apparatus belonging to this establishment, has acquired celebrity, from the publication, in the Haarlem Transactions, *Annales de Chimie*, *Nicholson's Journal*, &c. of many curious experiments made with it by Dr Van Marum. Models of Mont Blanc, and the Alps and glaciers around, occupy a

small adjoining apartment. These were, for a long time, highly valued; but the general diffusion of the fine models of the same wonderful scenery, executed in *papier maché* by Troyé (now of Frith Street, Soho, London), has lessened their interest.

Schneevoigt's Bloemistry.

Leaving these museums, we again bent our steps to the region of bloemistries, near the Wood of Haarlem. Having formerly remarked, in the bay-window of a bulb-shop, several plants of the red-leaved ananas, commonly denominated "Bloody Pine-apple," and regarding this as probably indicative of the general superiority of the collection in the wareroom, as well as in the grounds connected with it, we were anxious to explore both. Although we entered without the slightest introduction, we were politely received by Mr Schneevoigt, formerly a partner of Mr Voorhelm; and as soon as he perceived that we possessed some knowledge of plants and fruits, and took an interest in his collection, he invited us to inspect the whole, and gave us every explanation we required.

This seemed to us to be one of the most extensive and best managed flower-gardens of Haarlem. In some of the others which we had visited, there was an appearance of narrowness or poverty; but here all the arrangements were on a liberal scale. The flower-bulbs were exceedingly numerous, and were to be seen almost at one view in a handsome store-room. The glazed houses and frames were neatly kept; there was, however, nothing peculiar in their structure, excepting that, in the hot-house, the covers of the flues were of iron.

There is here a large collection of the bloody pine-apple already mentioned, a variety not of very usual occurrence.

Mr Schneevogt shewed us a drawing of an uncommonly fine fruit of this kind, produced in his pinery some years ago: the solid part of it had been nine inches long, and the fruit and crown-leaves together had measured twenty inches in length or height. Of the golden-striped ananas the collection is also extensive; but this variety is more distinguished for shewy appearance than for being productive of fruit. In the same stove are several uncommon varieties or monstrosities of the ananas.

The fruit on a particular pear-tree in the garden having caught the notice of Mr Macdonald as of unusual appearance, we were induced to inquire about it, and were told, that it was the *Foppen pear*, the principal kind which is dried for use. Whether it be named in honour of the author of the *Bibliotheca Belgica*, or what may be the etymology, we are uncertain. In its recent state (at least at this period of the season) it did not seem to be of very desirable quality. When intended to be stored, the fruit, shortly after being gathered, is carefully peeled with a knife; and is then, without further preparation, dried in a baker's oven. It becomes shrivelled, brown, and hard; and will, in this state, keep good for several years. Mr Schneevogt brought to us from his dwelling-house dry specimens of crops 1815 and 1816, and also an assiette containing some which had been recently stewed for dinner, and which were swelled out to a considerable size. The appearance of the dish was certainly not inviting, but the flavour was by no means disagreeable.—The *Derkjes pear*, we were informed, is frequently dried in the same way.

The grape-vine called *Blue Frankenthal* covered several walls in this garden, and was highly praised by Mr Schneevogt. This season there is very little fruit; and the bunches are still (30th August) so backward, that we

should doubt their acquiring maturity. We were assured, however, that the crop is often abundant, and that, in warm years, it does not fail to ripen.

The general collection of showy plants is very choice. In the open border, the Fish-bone thistle (*Cnicus Casabonæ*) was still in flower; and many of the flowers being already past, there can be little doubt of the plant ripening seeds, so that it may be here continued for many years without importing the seeds. Some of the rarer Orchideæ, particularly of the genus *Cypripedium*, grew luxuriantly; and were at this time beautifully in flower, the soil appearing to be well adapted to this tribe of plants. The Atamasco Lily (*Amaryllis Atamasco*, sometimes called, in the Dutch catalogues, *Lilium uniflorum*) seemed also to have been strong; but the flower was past. The Superb Corn-flag (*Gladiolus cardinalis*) was now in full splendour. *Lobelia fulgens* is treated in a peculiar way: the plants are kept in a greenhouse till very near the time of flowering; the pots are then placed in a small pond, or in a box containing water, in the open air, and are plunged just so deep that the water barely covers the surface of the soil: in this way the bloom is enriched, the flowers get larger and more brilliant, and they endure much longer. The double-flowering white *Lychnis* (*L. dioica* var.) here grew in large tufts; and the still rarer variety, with pale red or rosy petals, formed a delightful ornament. A large bed is appropriated to the tuberous-rooted Swallow-wort (*Asclepias tuberosa*); and at this time the effect was brilliant, many hundreds of the flowers being displayed. The site is changed every third year; and in the first year after transplanting, the flowers do not come strong. During winter, the bed is covered with tree-leaves or any kind of dry litter. Mr Schneévoigt has raised from the seed several varieties of this plant, with the blossoms of different

tints ; but none of them, so far as we noticed, surpassing in beauty the native colour of the flower. As at Antwerp, seedling Dahlias, which had been sown this year, were already in flower ; but Mr Schneevogt possesses only two or three sorts of double dahlia ; and Mr Smetz's collection remains the finest we have seen.—A small stove for tropical plants was enlivened by several very showy flowers. The Yucca-flowered Amaryllis (*A. ornata*) had been in splendid bloom, but was on the decay ; while *Columnnea hirsuta* was beginning to expand its large variegated blossoms, and was finely contrasted with the rich scarlet of numerous plants of *Cyrilla pulchella* *.

Mr Schneevogt invited us into his house, and shewed us a part of his botanical and horticultural library, which we found to be rich in German publications that are little known to the gardeners and orchardists of Scotland. We had the satisfaction, in particular, to see the extensive periodical work of J. B. Sickler, of which twenty-two volumes in octavo were published between 1794 and 1804, under the title of "Teutsche Obstgärtner." At this period, Mr Sickler changed the form and title of his publication ; and, under the name of "Allgemeines Teutsch-garten Magazin," eight successive volumes in quarto came out ; when the great war, which agitated the whole of Europe, occasioned the discontinuance of this useful work. Again, since the restoration of peace and order, has this indefatigable horticulturist commenced his labours ; and the con-

* In a tanners-bark pit which the workmen were clearing out, we saw several hundred specimens of the Stag-beetle (*Lucanus cervus* L.), in all the stages of its existence and metamorphoses,—in the state of eggs, caterpillars, larvæ, and perfect beetles. This formidable-looking insect sometimes occurs in England, and is the largest of the coleoptera found there : it has not, we believe, been observed in Scotland.

tinuation of the work is now announced for publication by Mr Frertuck, at the Industrie Comptoir in Weimar. Mr Schneevogt shewed us likewise a very uncommon sort of publication, intimately connected with horticulture. It is entitled, "Pomologisches Cabinet." Instead of being illustrated with coloured engravings, each fasciculus of the work is accompanied with a box of casts or models, apparently made of wax, and tinted after nature. The models are executed by an artist at Erfurt, but the publication issues from the Industrie Comptoir of Weimar already mentioned. Twenty-six fasciculi, and their corresponding boxes of models, are already published. The expence of each fasciculus and box is about a ducat (nearly nine shillings). It would be desirable that both of these publications should be procured for the library of the Horticultural Society.

Before bidding adieu to the bloemistries, we may mention, that the principal florists commonly unite in publishing yearly a general catalogue of their bulbous and tuberous rooted flowers. This is entitled, "Groote Hollandsche Catalogus van de aller voortreffelijkste Bol-Bloemen." Hyacinths take the lead, and are followed by Tulips, Ranunculuses, Anemones, and Polyanthus-Narcissus.

Of double-flowered *Hyacinths*, of different colours, reds, whites and blues, it enumerates more than 800; and of single-flowered about half as many.—But we have already enlarged sufficiently on the subject of hyacinths, and shall now say something regarding

Tulips.—Towards the middle of the 17th century, the culture of these was more ardently pursued than at present. What has been called the *Tulipomania* then reigned; but many ridiculous stories have been told of the extravagant prices paid for tulip roots; for the mania did not, we believe,

so much consist in giving large sums for established variegated tulips, as in a kind of betting, regarding the eventual superiority of promising seedling flowers, and in a ruinous competition for the possession of *breeders* of high merit, from which fine seedlings might be expected. The early-flowering or *spring* tulips (such as Duc van Thol), when they first came into vogue, and while they continued scarce, were frequently rated at ideal values; and the anxiety of the amateur florists to excel, frequently, in the midst of such temptations, became the means of involving them in bankruptcy. The greatest rarities were sometimes disposed of by a kind of raffle. At length, the interference of the Dutch Government was thought necessary, to restrain this gambling spirit of the votaries of Flora. But those days have passed away. There is certainly, at this time, no "sumptuary law limiting the price of tulip roots," nor is there any longer the slightest danger of "12 acres of land," as one author says, or "L. 5000 Sterling," as another reports, being given for a single tulip. The general price of choice bulbs now varies from 3 to 10 guilders (the guilder = 1s. 8d.); a few kinds are valued at from 10 to 20 guilders; and the most select new, and consequently rare varieties, seldom fetch more than from 20 to 50 guilders. Among the most precious at this time are the Universal Conqueror, Pompe funebre and Charbonier noir, with yellow grounds; Louis the Sixteenth and Toilette superieure, with white grounds; and the price of these is 100 guilders (L. 8, 2s. 6d.) a bulb.

No little attention, however, is still given to the cultivation of tulips at this place; and the principal florists here have their favourite breeders, and are yearly gaining new varieties from the seed. A *breeder*, it may be explained, is a seedling tulip, which has attained maturity, but is still

young and in vigour, being only eight or nine years from the seed. If such a tulip have a strong tall stem, and large petals, blunt or rounded at the end; if it be self-coloured, or of one uniform equal colour on both sides of the petals; if the base be either pure white or bright yellow; and the anthers and stigma black or very dark,—it is accounted a breeder of first-rate qualities. The bulb of such a breeder is planted deeper than usual, in a very sheltered sunny place, and the utmost care is taken to prevent its leaves from being injured by wind or hail; the stem is tied to a stake, the flower is protected from the scorching rays of the sun and from violent rain, and the perfecting of the capsule is encouraged; the seeds are carefully gathered when ripe; and from these seeds, in a course of years, many fine variegated flowers are expected, partaking of the fundamental good properties of the breeder. When the self-colour of the petals of a breeder begins to *break*, the bulb is regarded as past its highest vigour; no judicious florist, therefore, ever sows the seeds of variegated or aged tulips; on the contrary, the capsules of these are cut off as soon as the flowers have wholly decayed, to prevent an unnecessary expenditure of the juices of the bulbs. All the splendid large tulips called by the Dutch *Primo Baguets* (from the stems resembling *baguettes* or little walking-sticks) have issued from one excellent breeder; all those beautiful varieties called *Baguets Rigauds* (perhaps *rougeaudes*) have also proceeded from one choice breeder; and in like manner, all the *Verports* or *Incomparables* are the offspring of one favourite parent plant. What are called *Bybloems* (or *neat flowers*)—the *Flamands* of the French florists—are derived from different breeders, but all having a pure white base: of these more than 300 varieties are mentioned in the catalogues.

Bizarres are also from different breeders, but all having the base of a clear yellow; and of these above 300 kinds are likewise enumerated. Of *early* or *spring* tulips, more than 100 sorts are mentioned. These were the kinds most highly prized two centuries ago; but now they are comparatively neglected. Some of these are early flowering varieties of the common tulip, *Tulipa Gesneriana*; others of a small size, belong to a distinct species, *T. suaveolens*: but Dutch florists do not regard botanical distinctions so much as the purity of the base and ground colour, the decided tint of the tracings and markings, the dark colour of the anthers and stigma, and the rounded form of the petals. There are many *double* tulips; but to these a true florist, of correct taste, is nowise partial. What we call *Parrot-tulips* the Dutch denominate *monsters*; a name, however, equally applicable to the double-flowered varieties.

For the *Ranunculus* and *Anemone*, the soil of Haarlem is not so favourable as for the hyacinth, or even the tulip. To the *Polyanthus-Narcissus*, however, it seems well adapted, and large quantities of this bulb are here cultivated.

Besides the general catalogue above mentioned, several private lists are yearly published. As might be expected, it not unfrequently happens, that in different bloemistries the same variety of tulip or hyacinth receives different appellations. The rivalry of trade either prevents these florists from concerting names, or incites them to employ names of their own invention. The heterogeneous nomenclature thus produced is amusing for its pomposity, and for the ingenuity with which it is contrived to catch the notice of the great, or to flatter the prejudices of foreigners. The *Soverein van de Nederlanden* is now brought forward as a finer flower than the *Koning van Holland*; and *La Reine Hortense* is this year superseded by *La Duchesse de Berri*.

A loyal Englishman is supplied with *Georgius Tertius* of several different colours; or with *Guillaume Pitt* or *Mynheer Fox*, as he may incline; while *General Washington* and *Mynheer Franklin* are at the service of those who come from the other side of the Atlantic.

It seems strange that none of the modern *Haarlem* florists has published a book on the culture of bulbous-rooted plants. We inquired in vain for any recent work on the subject; and believe that none has appeared since the days of *Van Kampen*. The earliest account of the Dutch modes of culture which we have met with, is contained in a small volume entitled "*The Dutch Gardener*," by *Henry Van Oosten* of *Leyden*, published about the year 1699, and translated into English in 1708. Seventy pages of this little work, it may be noticed, are occupied in treating of tulips, while hyacinths are dispatched in four,—a clear proof of the superior estimation in which tulips were then held. Some additional particulars may be found in a tract entitled *Le Jardin de Hollande*, published at *Leyden* by *John du Vivier*, a few years after the former. The author appears to have been a French Protestant refugee, and to have written chiefly for the use of his countrymen, who, like himself, had been compelled to flee, upon the revocation of the edict of *Nantes*. "Par ce petit ouvrage," he says, "j'ai voulu procurer quelque douceur et quelque plaisir à plusieurs d'entre les François, qui s'étant tenus fermes dans leur sainte religion, et ayant conservé leur conscience pure, sont venus s'établir dans ces bien heureuses Provinces."—Strange! that, after the lapse of a century, in which the progress of knowledge and of liberal opinions has made rapid advances in most parts of Europe, we should again begin to hear of the persecution of Protestants in France! and that, too, at a moment when

many of our own countrymen are exerting themselves for the removal of the few remaining disabilities to which Roman Catholics are subjected in the British Islands.

We have to add, that a very distinct account of the Dutch mode of cultivating bulbous-rooted plants, may be found in the Scottish work already referred to in a preceding page (p. 187.), entitled "The Scots Gardener's Director," by James Justice, F. R. S., published at Edinburgh in 1754. Mr Justice had twice visited Haarlem before that period, with the express view of making himself acquainted with the Dutch methods of cultivation. The directions which he gives for the culture of bulbs, and particularly for the preparation of a suitable compost, are accurate and judicious; and to the neglect of the rules which he has so well laid down, may, in a great measure, be ascribed the very general want of success in this branch of horticulture in Scotland, for a number of years past. He mentions that the "oriental hyacinth" was his "peculiar favourite;" and informs us, that he not only completely succeeded in preventing the imported bulbs from degenerating, but "raised many of these fine flowers, of incomparable beauty, from seeds saved in his own garden near Edinburgh,"—Crichton, situate to the southward of Dalkeith. The excellent florists of Lancashire, Cheshire, and Yorkshire, have produced many beautiful seedling tulips; but hyacinth culture is there accounted so difficult, that they seem to resign it in despair,—hyacinths never appearing in their flower-shows nor prize-lists. It is somewhat curious, therefore, that not only the management of old bulbs, but the raising of seedling hyacinths, should have been carried to perfection in Scotland seventy years ago, and that this art should now in a great measure be lost in the country. Mr Justice treats much more fully of hyacinths than of tu-

lips; indeed, his writings and example probably tended in no slight degree to increase the demand for the former flower, and thus to influence the zeal of the Haarlem dealers.

About ten years after the publication of Justice's work, appeared "The Dutch Florist," by Nicholas van Kampen of Haarlem. It was translated into English, and printed at Newcastle-upon-Tyne in 1763. The hyacinth now takes the post of honour, in being first treated of; next comes the tulip; and the ranunculus and anemone follow. These are styled "the four principal ornaments of Flora;" for the polyanthus-narcissus was then only rising into estimation. The work is brief but valuable; for the author writes in an unassuming and perspicuous manner, and gives the result of his practical experience as a cultivator. In every material point, his remarks confirm those of our excellent countryman.

As the works both of Justice and Van Kampen have become rather scarce, the florist will not be displeased to find, in the Appendix, No. IV. a few extracts from them, regarding hyacinths; and he will thus have an opportunity of comparing their modes of culture with that of Kreps, (App. No. II.)

Kreps' Tree Nurseries.

In the afternoon, Mr Kreps *senior* accompanied us, along one of the avenue roads of Haarlem Wood, to his nearest *kweekery* or tree nursery, situate somewhat more than a mile to the south of the town. Here we saw a large collection of fruit-trees. The general aspect of these was very different from what we had been accustomed to, in the nurseries of our own country. Among the trees accounted ready for sale, the youngest had evidently been trained for not less than five or six years; many had been eight, nine, or even ten years

under training, after having been originally grafted on strong and tall stocks, or what is called full standard high. Of the apple and pear trees, some were of the cup-shape, with a hoop in the middle ; these were on paradise-stocks, and planted as closely in the quarters as we do gooseberry-bushes. Others were of the flat crown form ; and many were pyramidal. This last mode of training has been occasionally practised in Holland for more than a hundred years ; but the French having recently adopted it, and given it eclat, it has now become more frequent. The trees are very handsome, being grafted near the ground, and having the lower branches somewhat spread, but the successive branches, upwards, shorter and shorter, till the leading shoot forms an apex. It is scarcely necessary to add, that most of these trees now displayed more or less of their fruit. The cautious Dutchman has thus no occasion to run any risk of being disappointed as to the peculiar variety of fruit which he purchases : he may select his trees in the course of the autumn previous to planting, and may see and taste their fruit. These trees, as long as they remain in the nursery, are removed from one spot to another, every third year. Without this precaution, the roots would extend so much, that the removal of the plants, when sold, would be difficult, and the recovery of their vigour, or renewal of their growth, would be slow. By reason of the frequent removals, however, the roots continue short or bushy, and may even be raised with a ball of earth adhering. The growth of the tree is, at the same time, rendered stunted, which seems to be another desirable object with the Dutch nurserymen, at least in regard to many of their fruit-trees. Those trees which had not been removed in the preceding year, bore a considerable crop of fruit at this time ; but we were also shewn some which, although they had

been transplanted only last year, were likewise yielding fruit. In this way, the citizen who hires a *tuinhuisje* for a single year, may gather fruit from trees of his own planting: they must, however, be removed from the nursery before the 1st of March, and great care must be bestowed, both in raising and planting them, to preserve the roots from being injured, and the soil from being detached.—The fruit-trees in this nursery were, in general, in a healthy state. Mr Kreps mentioned, that he had found common soft or black soap, rubbed on the bark, sufficient to destroy the apple aphid, or at least to prevent it from extending its ravages.

This season had, upon the whole, been unfavourable to the swelling and colour of the fruit, more especially of young trees, partly shaded by others; so that we could not judge even of the external characters. Few of the pears were ripe, and very few of the apples had yet made any approach to ripening; although, therefore, we tasted all the kinds that appeared not common at Edinburgh, we were not able to form any correct opinion concerning their merits. We took a list of such as were accounted superior in quality, and ordered plants of the following kinds.

PEARS.—Bergamotte de Soulers. Foppen-peer. Roskammer; which proved to be the same as our Colmar. Dubbelde Riet peer. Jutjes-peer; this last particularly deserving of attention.

APPLES.—Enkhuysen-appel. Blanke Aagt; Roode Aagt; (which *Aagts* are allied to our Pearmains.) Framboos-appel. Zwarte (black) Engelse Appel. Konings Pipling. Oostindische Compagnie. Passe-pomme blanc. Passe-pomme rouge. Blanc Rabauw. Princesse Noble. Red Jerusalem, (like the French Pigeonnet.) Double Paradise. Roode Bellefleur. Blommee. Venken-appel, (which is the Anise Bennet). Wyker Pipling. Zoete (sweet) Re-

net. Zuur (sour) Veentjee. Of these, the *Blanke Aagt* and *Wyker Pippin* were particularly recommended to us.

We ordered dwarf-trees, of two years standing; two plants of some, and four of others. We also ordered plants of the Blue Frankendale and White Early Candia grape-vine*.

The following ought also to be procured from Haarlem for the Society's garden, as soon as it is established. *Pears*: Bergamot blanc. Calbas musqué. Citroen de Cirene. Culotte Suisse. Gezegende-peer. Persik-peer, (probably Poire-pêche of the French). Suyker (sugar) peer van de Neufville.—*Apples*: Caracter, (Fenouillet jaune, or Drap d'Or?) Dubbelde Renet. Kandy Zoet. Blanc Zoet. Zoete Renet. Zoete Veen. Zoete Zon-appel.

Cherries are likewise placed on old or strong stocks, and are therefore worked in the mode called cleft or crown grafting. Handsome and healthy trees are not produced in this way; and our own plan of *budding* cherry-trees is greatly superior. Viscid and ductile clay being scarce in Holland, a kind of grafting cement or *mummy* is employed for covering the grafts at the place of junction, both in the case of cherry-trees and of apples and pears: this cement is composed chiefly of pitch, having a little coarse wax and turpentine mixed with it; and some appearances seemed to indicate that it had been applied with the aid of a hot iron. Mr Kreps mentioned, that it did not answer very well, and that he considered clay, mixed with chopped straw, as preferable. When the mummy is used, no bandage is employed; the want of which, we should think, must occasion frequent failures.

* These all arrived at Leith in the course of winter 1817-18; but, owing to the Society having no public Experimental Garden, they were necessarily placed in different private gardens.

Upon inquiry, it did not appear, that, during the twenty years of war, in which England had little or no connection with Holland, any one in the last mentioned-country had peculiarly turned his attention to the raising, from the seed, new varieties of the common fruits, apple, pear, plum, or cherry. Indeed, Holland is not likely to take the lead in such horticultural essays; the people are proverbially averse to changes, and fond of keeping things in the old style. Mr Kreps informed us, however, that he had some years ago selected a good many apples and pears from the nurseries at Paris, with which he was previously unacquainted; but that experience had led him to consider only three or four of them as worthy of being retained or classed among the better kinds suited to the climate of Holland.

We have seen, that a Dutch merchant retiring from business, may purchase fruit-trees which will yield him their produce the very first year: we found that he may also surround his garden and shrubbery with *ready-formed hedges*! We observed many lines of different evergreen and deciduous shrubs usually employed for this purpose, trained hedge-wise in the nursery; and these, like the fruit-trees, being frequently removed from one spot to another, may, almost without hazard of failure, be transferred to a considerable distance, and replanted. We noticed a hedge-row of evergreen privet three feet high, and another of savin-tree (*Thuja occidentalis*) between four and five feet high, which were ready for sale. A few box hedges, trained to particular shapes, with loftier bushes cut alternately to the form of balls and of vases, were still kept in the nursery; and also a few tall and old box plants, tortured into the fancied resemblance of animals. These were much in demand in former times; but Mr Kreps remarked (what had occurred to ourselves in the course of our passage from Rotterdam

to this place), that the taste for topiary work had greatly declined in Holland, and would probably soon be extinct. From the same nurseries the retired merchant may at once plant his grove or his avenue with forest-trees twenty feet high. These tall forest-trees are transplanted, in the nursery-rows, every third year, like the fruit-trees; and can thus be removed without much risk of going back. Mr Kreps added, that, since the peace, he had on one occasion sent a ship-load of such forest-trees to Russia, many of them from twenty to twenty-five feet in height, and that very few had missed.

In passing a few nursery lines of occidental plane, we happened to mention the decay and death of the greater part of our fine British specimens of this tree in the year 1814; when our conductor, with some surprise at the coincidence, told us, that the same inexplicable mortality had occurred among those in Holland during the same season.

From an oak-stub in the nurseries, Mr Hay gathered a large specimen of *Boletus ignarius*, the principal fungus from which amadou is manufactured. This amadou is imported in considerable quantity from Hungary, and, under the name of *boomzwam*, is sold at all the hucksters-stalls of Holland, being found a convenient portable tinder, highly useful to people so habitually devoted to the tobacco-pipe, and who are not likely soon to abandon the clumsy *tondeldoosje*, with its flint and iron, for the elegant phosphoric match-bottle.

In walking homeward, the conversation turned on the value of land in Holland. We learned, that, near Haarlem, land of indifferent quality is let at 80 guilders a-year, or 50s. Sterling, for the *gemet* or Dutch acre, which is nearly equal to 30s. the Scots acre, or 24s. the English; and that land of the best quality is let at 40 or even 50

guilders (3 to 4 guineas) an acre; in both cases with the view of being occupied as pasture only. Market-gardeners pay for land, at some distance from town, $2\frac{1}{2}$ d. English *per* fall, which is equal to £6, 5s. Sterling for the Dutch acre, or at the rate of £3 : 14 : 6 the Scots acre, or near £3 the English; near Haarlem, the rent is perhaps quadrupled; such land as Messrs Kreps occupy in nursery crops paying perhaps 10d. *per* fall of rent, or about £25 Sterling the Dutch acre, (equal almost to £12 the English acre, or £14, 10s. the Scots,) besides public burdens, which in Holland are numerous and heavy, particularly for the support of the dikes, water-mills, and drains.

The Cathedral.

Aug. 31.—This being a Sunday, and the last we should spend in Holland, Mr Hay and I went, as early as half past nine in the morning, to the Grote Kerk, that we might witness the mode in which the whole services of the day are conducted.—To some readers, a few sentences on this subject may be agreeable: others may pass them over; for we readily admit that they are scarcely in place in a horticultural tour:

Till the minister enters, the clerk reads the Scriptures. As soon as the pulpit is occupied, the singing of a psalm is commenced; the number of the psalm and verse having been previously announced by means of small telegraphic frames, placed in conspicuous situations, with large moveable Arabic figures. Every one has heard of the grand organ which fills the west end of this church. The tones are indeed very fine; but they are soon lost in the still more impressive notes of a thousand voices, the whole congregation cordially joining in the hymn. To enjoy the organ in perfection, therefore, the visitant should remain after the service is finished, when, upon the congregation retiring,

strangers generally find means to persuade the organist to perform some piece of music, calculated to draw forth the full powers of the instrument. In the centre of the church, great numbers of the people, particularly ladies, are seated on reed-chairs, and the handing of these over heads, for dames of distinction who enter late, is a continued exercise for the politeness of the gentlemen. The female attendants, who furnish *chauffé-pieds* full of red-hot peats to the ladies, are likewise continually passing and re-passing with these odd-looking appendages of a church; but none of these things for a moment retard the progress of the devotions. During prayer, the men assume the standing posture; the women meanwhile sit devoutly still: the poorest female being furnished with a large fan, which she continues to hold before her face during this solemn part of the worship. When the prayer is ended, the men are seated, and most of them now put on their hats. This practice of being covered in church, we may observe, has sometimes, without reason, given umbrage to well meaning English travellers, who seem to have forgotten that they belong to a communion in which the *consecration* of churches is considered as a duty, while in Holland, as in Scotland, it is condemned as a piece of superstition. The tourists alluded to, had not probably observed also, that the hat is not worn in the time of prayer or praise, but only during the sermon; nor had they considered, that a Dutch sermon commonly endures for an hour and a half, and that a huge-Gothic edifice must necessarily be somewhat cold and damp in such a country as Holland. In point of fact, in the Dutch churches there is less coughing, or less indication of catarrhal affection, than in the Scottish; but this is not wholly to be ascribed to the comfort of foot-stoves, and the wearing of hats; for although the air of Holland is moist,

the alternations of temperature are less frequent and less violent than in Scotland.

There are no galleries in this church; and we fancied that the Great Kirk of Haarlem exhibited at this day the appearance which St Giles's at Edinburgh probably made in the time of John Knox, before it was subdivided by partition walls, and disfigured with *lofts*. As usual, the walls are occupied with the achievements or escutcheons of rich burgomasters, in place of the works of Rubens or Vandyke. In the middle of the church are suspended two models of ships, having small saws attached to their keels;—sacred memorials of the taking of Damietta, by means of Dutch vessels so accoutred, cutting a chain which the Saracens had extended across the mouth of the harbour.

After the morning service, we viewed some of the charitable establishments of the place, and also some fine public walks on the outskirts of the town.

Meantime Mr Macdonald returned from a visit to Mr Eldering at Overveen. He had likewise examined the nature of the sand-hills, and found their botany rather more interesting than might have been expected. The hollows among them abounded with the round-leaved winter-green (*Pyrola rotundifolia*), at this time only in full flower, being, probably owing to the peculiarity of the situation, fully a month later than in England. The angular-stalked Solomon's-seal (*Polygonatum vulgare*) was common, and many of the plants were still in flower. *Epipactis latifolia* was of a large size, and not uncommon. It is somewhat remarkable, that the plants which have just been mentioned are generally considered as inhabitants of woods, while the sand-hills are bare,—a few stunted bushes of *Salix alba*, and some straggling sea-buckthorns, being almost the only woody plants which diversify the waste. *Silene*

Otites, *Jasione montana*, *Agrostis setacea*, *Aira canescens*, and *Carlina vulgaris*, are likewise plentiful. All of these are British plants, though not of general occurrence in our country. *Erigeron Canadense* * was the only plant, not a British native, which Mr Macdonald observed on these sand-hills; but his examination was necessarily rapid, and of confined extent. The dewberry and the hazel-leaved bramble (*Rubus cæsius* and *corylifolius*) in many places covered the sand with their decumbent runners, rendering it difficult to walk; and the fruit was at this time very abundant.

The afternoon service in the Cathedral did not begin before five o'clock, and it continued till near seven. We now had an opportunity of seeing the sacrament of baptism dispensed to several infants. The service is read from a book, and occupies a considerable space of time; while *both* parents, or rather their representatives, the *doop heffer* and *hester*, present the children. The clergyman who officiated at this ceremony, was not he who had preached, but a more elderly personage. The font stood on a covered table; and the minister, taking each infant in his arms, as practised in the Church of England, sprinkled it with the lustral water three several times, as he slowly and solemnly pronounced the sacred names of the persons of the Trinity.

There are several excellent *private gardens* in the neighbourhood of Haarlem. One of the most distinguished for

* This, as implied in the trivial name, is an American plant. The late M. de Jussieu was of opinion, that it had been first introduced into France by means of seeds sticking among the fur of the beaver-skins imported from Canada. The seeds being furnished with a fine pappus, are readily transported to great distances by the winds: we had gathered it upon old walls at Bruges, and Mr Macdonald now picked it up on the downs of Haarlem. It has also, of late years, appeared on the shores of England.

fruits of all descriptions, belongs to William Willinck, Esq. at Bosch-en-Hoven. Our limited time prevented us from visiting it; but we were informed by a very intelligent friend who had been there, "that the crops of grapes, peaches and nectarines in the *open air* (that is, without glass, but against a wall) were very fine; and the state of the trees evinced the judicious management of Mr Francis Eggenraam, the gardener. One plant of the Frankendale grapevine covers more than a hundred feet of wall. Apricots are brought to maturity on the walls here as early as the month of May, by a simple mode of forcing. Glass frames or sashes, inclining from the top of the wall to the ground, are placed over the trees in the preceding December. Besides the reflection from the glass, the only artificial heat employed arises from the fermentation of a layer of stable-dung, about a foot in thickness." The garden of Mr J. Willinck, at his villa called Bosch-en-Vaart, is nearly of equal merit; and Mr Goll van Frankensteyn at Velsen, is regarded as a very successful cultivator of fruit. All of these gardens possess a soil similar to that which we have described when speaking of Mr Eldering's at Overveen, a rich vegetable mould incumbent on a stratum of pure sand. Although the fruit-trees and ornamental shrubs are in the greatest luxuriance, we are assured that manure of any kind is seldom or never applied to the borders; the regular dunging being confined to those quarters of the garden in which kitchen-vegetables are reared.

We learned that Mr Schentzer has a garden, containing an excellent collection of apple-trees, which he propagates for sale. But the largest and best nurseries for fruit-trees are situate, as already remarked, on the other side of the Haarlem Mere, at a place called Boskoop.

The mention of this place leads us to a remark regarding *Dutch strawberries*. At the Hague, Leyden, and

Haarlem, the native species, *Fragaria vesca*, is preferred for culture, and is very generally known by the name of *Boskoop* strawberry, from the circumstance of the plants being procured from the woods at Boskoop. The wild strawberry is found to possess the property of continuing very long in fruit, like the Alpine with us: at Haarlem, the fruit is sometimes gathered for nine months in succession, from March till November; but it is to be understood, that different lines of the plants have been dressed at different periods of the season, and that attention has been paid to watering the rows during the parching droughts of summer. The cultivated plants are regarded as exhausted after the second year; they are therefore rooted up and destroyed, and a new supply is obtained from Boskoop.

The district of Rorwick has generally been described as dull and uninteresting. We have found it otherwise; and we may be excused for once more remarking, that in April and May the environs of Haarlem must be truly delightful to the zealous florist.

Haarlem to Amsterdam.

Sept. 1.—The 1st of September having already overtaken us, we determined immediately to proceed to Amsterdam; and, in order to vary the mode of travelling, we hired a voiture to take us thither. We passed several pretty villas, ornamented with tall hedges, avenues, and groves, and soon came to the banks of the great lake, or Haarlem Mere. At a place called Swanenberg, a very narrow neck of land only, and that evidently artificial, separates the waters of this lake from those of the River Y, which are on a different level. This River Y is merely a branch of the Zuyder Zee, so named on account of

its shape somewhat resembling the letter Y. The high-road passes along the neck of land; and while we were detained at the *tolhuis*, or petty custom-house, we had an opportunity of viewing by far the largest and strongest sluices which we have yet seen in Holland. The entrance to Amsterdam in this direction is favourable for producing effect. It is indeed impossible for a stranger not to be impressed with admiration at the industry and enterprise of a people who could establish, in the midst of a level marsh, so vast a city as here opens to view, which seems every moment in danger of being overwhelmed by the brim-full canals and wide expanses of water which encompass it.

AMSTERDAM.

We found the city in a bustle, the great kermis having just commenced, and *kraams* or temporary shops being erected on many of the quays. We drove to the Bible Inn, to which we had been recommended. The people are civil enough, but the accommodation is not the best. The street is one of the busiest, but very narrow, scarcely any where exceeding twenty feet broad; while the back-windows look out upon a canal which, at this warm season, is most offensively feculent. The most airy streets are the Keyser-gragt, the Heeren-gragt, and the Cingel; and in the hotels in these, (the Doelen, Amsterdam Arms, Swan, and others), much superior lodging and attendance may be had.

The Plantagie.

In the afternoon we walked to the Plantagie, situate to the southward of the city, and the favourite promenade

and ride of the inhabitants. This is a large flat space, resembling in shape the Meadows, or Hope Park, at Edinburgh. It is laid out in several long avenues, which diverge a little from one another; and these are intersected here and there by cross roads. Rows of tall forest-trees line the principal avenues; and a few under-trees and ever-greens are interspersed. The principal baths of Amsterdam are placed at the extremity of one of the walks. All around the Plantage are numerous neat small houses,—“company-houses,” as they are often called, being used chiefly for giving dinners on a Sunday, or tea and coffee in an afternoon. They are surrounded by little gardens, which are neatly dressed. These retreats chiefly belong to merchants engaged in business in Amsterdam, and who, during the heats of summer, must be glad to escape thither from the sickening stench of the capital.

Botanic Garden.

We visited the Hortus Medicus, which is also in this pleasant quarter. We were charged with a letter from a gentleman in Rotterdam to Mr John Pfister, the superintendant of the garden, and were fortunate in finding him at home. He obligingly walked through the garden with us, and seemed to take much pleasure in shewing us all his best plants. The grounds are but of small extent, not nearly equal to the present Botanic Garden at Edinburgh, (meaning the one at Leith Walk.)

The Dutch having long possessed the Cape of Good Hope, we naturally expected to meet with some fine old specimens of plants peculiar to the southern point of Africa, and we were not disappointed.—A large specimen of the Black Briony of the Cape, *Tamus elephantipes*, had a singular appearance. The *root-stock* of the plant has com-

pletely filled the barrel or round box in which it had been placed, and now rises considerably more than a foot above the margin of it: it is harder than cork; the smoother parts somewhat resemble the shell of land-tortoises, (*Testudo Græca* and *geometrica*); the rougher parts have a coarse scaly appearance, which has given rise to the name *Elephant's-foot*. The age of this curious specimen is probably not less than forty or fifty years. It has frequently flowered; but the *Tamus* being a dioecious plant, and only one sex existing here, no seeds have ever been produced*.—The Smooth Iron-wood (*Sideroxylon inerme*) is another Cape plant, of which there is here a large and fine specimen: the wood, as is well known, and as is implied in the generic name, is very heavy, and sinks in water.—We were rather surprised to find that the collection of Cape heaths was exceedingly meagre, not more than a tenth part of the number of species which may be seen at Lee and Kennedy's, or at Loddiges, existing here.

The Amsterdam garden had long been noted for a noble specimen of the Dragon's-blood tree (*Dracæna Draco*), which had reached the height of forty feet, and was eighty years old. We looked in vain for this specimen; and, on inquiry, found that part of the stem having decayed, the plant had been cut over in 1814†. The garde-

* The Cape Briony was introduced into England by Mr Masson. A male plant flowered at Kew in 1783; and a female at Mr Knight's, King's Road, in 1810.

† It was impossible that we should not have been struck with the coincidence of our own fine specimen of the *Dracæna Draco* in the Royal Botanic Garden at Edinburgh, having been lost in the same year. It was planted by Professor Hope, the father of the present distinguished Professor of Chemistry in the University of Edinburgh; was more than forty years old, and about thirty feet high: it was by far the finest specimen of the plant in

ner told us, that he had sawn off the top part, which, having been planted in a pot, had struck root; and he shewed us a small specimen as the identical top so cut off, but which, unless we had been informed otherwise, we should certainly have considered as a young plant, or sprung from a germ recently unfolded.

The *greenhouse* is of a large size, capable of receiving a numerous assemblage of tall plants; and, though constructed after the fashion of the oldest English greenhouses, may in this country be regarded as rather a handsome structure. In front of it grows a large vine, about eighty years old, and which spreads over the roof. It is of the Red Frankenthal kind, and by much the largest tree of this variety which we have seen, the stem being 2 feet 2 inches in circumference at three feet from the ground. The *hot-houses* for tropical plants, in immediate connection with the greenhouse, are also pretty extensive, but do not deserve any other praise. There is another stove, of great length, but extremely narrow, and altogether of an incommodious and awkward construction. There is no proper walk within it; and the roof consists only of single glazed frames or windows, which are sloped at an angle perhaps of 60°, and which are not moved like our sash-lights, but are opened and shut by means of hinges attached to the rafters. Here the pots containing the plants are sunk in tanners-bark. At this season of the year, there was only one row of plants in the middle of the house. The garden contains, in all, about 480 feet, in length, of glazed houses; but near 200

Britain. We regret to have to add, that the Edinburgh specimen was not lost on account of any inherent decay in the plant itself, but merely from the want of the necessary funds for raising the glass-roof of the dry-stove in which it was situated.

feet belong to the stove last described, the narrowness of which accounts for its length. The houses were already all shut up for the night, although it was early in the afternoon, the sun shining bright, and the temperature in the shade not under 66° Fahr. The heat within must at this time have been between 80° and 90°. That plants so treated should be *drawn up* and weak, did not certainly surprise us; we rather wondered that they looked so well as they did. Some cultivators of tropical plants, remarking that, in the West India Islands particularly, very cold nights succeed to the hottest days, have proposed to imitate such a climate at home, by closing the hot-house during the day, and throwing it open at night. But here the plants are excluded from air, not only while exposed to the burning rays of the sun, rendered more intense by the glass covering, but are carefully smothered up during the cool period of the night. Mr Pfister raised several of the frames of the narrow stove, to enable us to see the plants. *Calotropis procera* seemed the most remarkable one now in flower.

The greenhouse plants are numerous, and at this season occupied a sheltered corner in the garden, where they are placed very closely together, and arranged according to their height; the tallest farthest back, so as to present the appearance of a great sloping bank of southern foliage. During winter, many of these plants, for which there is not room in the greenhouse, are crowded into sunk pits, covered with glass-frames. These pits are intended chiefly for winter protection, when vegetation is dormant; plants left in them at this genial season, seem, as it were, buried alive. In this state, however, we observed several uncommon plants, generally much drawn up and disfigured. The Water-lily leaved Fig-tree, *Ficus nymphaeifolia*, may be

mentioned as an exception, a beautiful specimen gracing one of these subterranean repositories.

The hardy plants were formerly arranged after the method of Royen of Leyden ; but, about ten years ago, the present Professor, Dr Vrolik, made a new arrangement of them, according to the Linnean classes and orders, and also prevailed on the authorities of Amsterdam considerably to enlarge the boundaries of the garden. There is a separate arrangement of plants indigenous to Holland ; and its Flora, when thus concentrated, makes a respectable appearance.

As a matter of course in a Hortus Medicus, a division is allotted to plants used in medicine. The medical arrangement is indeed extensive, embracing all the more hardy species which have ever been recommended in the practice of physic, although comparatively few of them now enter even the pharmacopœias of the Dutch Provinces. The tallies are clumsily large, and, in genuine Dutch taste, painted red and white : after all, they have only numbers marked on them, not the names of the plants ; but there is a printed catalogue for the use of the students*.

The collection of succulent exotics is ample, and may be regarded as the boast of the Amsterdam Garden. It is rich in the genera Aloë, Agave, and Stapelia, and in the the natural orders Cacti, Euphorbiæ, and Ficoideæ. Two very large specimens of American Aloe, in vases, form ornaments at the gate. In the collection, we observed Aloë diaphana, and large plants of *A. arborescens* and *ferox*. Our notice was likewise attracted by a monstrous variety of *Stapelia hirsuta*, resembling, in its mode of growth, the

* “ Catalogus Plantarum Medicinalium in Horto Medico Amstelodami,” published by Mr Holtrop in Kalverstraat.

monstrosity of *Sedum virens* often cultivated in gardens. *Aquatic plants*, instead of occupying the borders of a pond, are kept in strong oaken boxes of great length, divided by occasional partitions, so that the depth of water can be varied. Many of the plants had flowered in this situation.

After the lapse of more than a century, we could hardly expect to find alive any of the plants described and figured by the Commelyns*. But in this garden also, most of Thunberg's eastern rarities were first cultivated; and several large bushes of *Aucuba Japonica* caught our eye as probably original plants, nor have we any reason to doubt that we were right in our conjecture. We saw one large plant of *Camellia Japonica*; but the many fine varieties which enrich our English collections are nearly unknown in Holland.—A specimen of Weeping-oak, *Quercus robur*, var. *pendula*, about twelve feet high, appeared to us an interesting novelty. Young stocks of the common oak were at this time planted around, in order to their being grafted, by approach, with the pendent variety; Mr Pfister intending to send a plant to Paris, where it is a desideratum even in the Jardin des Plantes. Should our projected Experimental Garden be established, we make little doubt of prevailing on the curator to transmit another to Edinburgh. Of other hardy trees, the most remarkable seemed to us to be a large deciduous cypress, the stem of which, at two feet from the ground, measured 5 feet $\frac{4}{8}$ inches in circumference.

In returning homeward, we passed through the *Jews' Quarter*. In consequence of the kermis, several thousands of the Royal People were now on the streets. The

* Hortus Amstelodamus, 2 vols. folio, 1701.

men were chiefly engaged in buying and selling. The women were walking about in their holiday dresses: many of them had very considerable claims to beauty, their features being regular and striking, and their complexions good: even the poorest of these Jewesses, we remarked, were adorned with rich laces. Many of these last were flower-girls: but the flower-market was at this time nearly deserted; Sunday, after morning service, being the chief day for nosegays, and Monday for the sale of showy plants and shrubs in flower-pots. The sallow complexion, the large nose, and the sonorous voice of the men, at once betrayed their origin. We experienced no more difficulty here in distinguishing the tone of a Jew, although he spoke Dutch, than in recognising the voice of an old-clothes-man in the streets of London. We felt that we witnessed a standing miracle, —the separation of this ancient “peculiar people,” from the various nations among which they are scattered; while the descendants of the Romans, who conquered the whole known world, who sacked Jerusalem itself, are already irretrievably blended with the inhabitants of all the countries of Europe.

“Amazing Race! depriv'd of Land and Laws,
 A general Language, and a public Cause;
 With a Religion none can now obey,
 With a Reproach that none can take away:
 A People still, whose common ties are gone;
 Who, mix'd with every Race, are lost in none*.”

Green-Market.

Sept. 2.—Early in the morning, Mr Macdonald visited the Prinzen-gragt Quay, at which the country barges arrive, from various districts, with culinary vegetables for

* CRABBE'S *Borough*, Letter 4.

the supply of this great metropolis. Both sides of the canal were crowded with punts, fully laden with all sorts of vegetable provisions. These, as fast as they are landed, are bought, chiefly by retailers, who have in waiting huge wheel-barrows,—about nine feet in length, the body of the barrow occupying six feet,—by means of which great piles of kitchen-stuffs are conveyed from the quay to all parts of the city.

Late *cauliflower* was brought in vast heaps, the flower, or eatable part, being large, and packed so as to be covered with the long leaves. In many cases, where the boats had come from a great distance, the mass of cauliflower had begun to undergo the process of fermentation; the heat was very perceptible to the hand, and the flower was discoloured. Where this had not happened, the quality of the cauliflower, in size, colour, and curd-like consistence, was unexceptionable; and if the Dutch, as is reported, used formerly to send to England for this vegetable, it is certain that they now have no occasion to do so. *Potatoes* arrived in great profusion, and were immediately carried off in wheel-barrows to store-cellars in the neighbourhood. *Carrots** were also very abundant, and at the same time excellent, being large, smooth, and clean. A kind of long carrot, intermediate between our horn and red carrot, was common: on account of its thick shape throughout, it affords a larger proportion of pulpy matter than the common spindle-form red, and it is both juicy and tender: this variety may therefore deserve the attention of the Society †. A pale red

* In Holland the carrot is commonly called *Geele-peen*, or yellow pin; the term *Carrot* being usually applied to the red beet.

† The *Atringham carrot*, introduced in 1816 to the neighbourhood of Edinburgh by Mr George Dickson, from Cheshire, possesses similar good qualities, and deserves to be more generally known. It is often called the

long carrot is likewise frequent, but does not seem in any respect better than our common long red. There were very few *turnips*, and those few not of good quality, which appeared rather odd; Holland being, according to our home notions, distinguished for the excellence both of the white and the yellow varieties. The small white turnip-*radish* was not uncommon; and the long-rooted black Spanish radish was plentiful. *Cabbages* of different kinds were common, particularly the Scotch or Drum, and the common red cabbage. Savoy cabbages also appeared, but not in great numbers. The quantities of long seedvessels of the white Dutch runner or *kidney-bean*, still brought to market, were uncommonly great. They came in upright baskets, and also in bags, each containing about a bushel. The seedvessels have now the young beans within them, almost fully formed, and would at once be rejected at a Scottish table; but when nicely shredded, and well stewed, they form even at this season a very palatable dish. Considerable quantities of broad *beans*, of the Lisbon, Turkey, and Windsor varieties, were also offered for sale: these seemed to be so ripe, as to be fit almost for seed. *Charlton peas* were plentiful, but evidently old, or belonging to an early sown crop. A few baskets of globe *artichokes* appeared. *Onions* were scarce, and of indifferent quality. There were some *leeks*, of the variety called London leek; but, as might be expected at this early period of the au-

Cheshire carrot, and sometimes the Green-topped, from the circumstance of the upper part of the root remaining above the surface of the soil, in the manner of mangold-wurzel, and thus acquiring a greenish colour. The root swells to a large size, tapers little, and ends rather abruptly; it is of a fine orange hue when cut, and soft and of a delicate flavour when dressed for table. The produce being great, this variety seems peculiarly well adapted for field-culture.

tumn, they were not good ; in Scotland they would have been accounted quite unfit for use. The supply of *red beet* at this morning market, was less than might have been looked for ; for we observed that a great deal of this esculent root is daily used by the common people, being hawked through the streets ready boiled. No *parsnips* were this morning to be seen in the Amsterdam market, which is singular ; this root being a favourite in the other towns of the Low Countries which we have visited. *Endive* was common, generally the plain Batavian variety. Of *lettuce*; the only kinds were the white Dutch, and the brown Dutch. *Purslane* was extremely abundant ; it came in broad shallow baskets ; and there were perhaps five hundred such baskets displayed. It was all of the green variety, which is the most hardy ; the golden or less hardy not being cultivated by the sale gardeners. There was a small supply of *spinage* ; likewise of garden *sorrel**, and of *chervil*. *Summer savory*, *tarragon*, and broad-leaved *sage*, appeared sparingly. *Celery* was not wanting, but was of a quality which in Scotland would be reckoned bad. It resembled ours when neglected to be transplanted ; and there seemed to have been no attempt at blanching the stalks. In the cultivation of this article, our gardeners certainly excel, and the Dutch are exceedingly deficient. At Ghent, it may be remarked, celery was good ; and it was tolerable even at Antwerp ; but throughout Holland it seems very indifferent. In the winter season, knoll-celeri or *celeriac* is, we understand, much used. In the gardens, this variety is only planted out in beds at this season of the year, as it swells very quickly in the latter end of the autumn.

* The *Zwaring* of the Dutch ; evidently the same word as the Scottish *Zurick* or *Sourock*.

The only vegetable which had, to us, any appearance of novelty, was the *Hamburgh parsley* root ; not that this is unknown in Scottish gardens, or in Covent-Garden market ; but it is little attended to in Britain ; whereas, in Holland, it is in high esteem, and is seen plentifully on the green-stalls,—being constantly eaten along with perch and carp, in the national dish of *waterzootje*.

It was not the season for seeing in the market several of the most common and useful vegetables, such as borecoles, Brussels sprouts, broccoli, and asparagus. For the cultivation of this last, the Dutch are celebrated ; and we had even heard that it was supplied by the gardeners till August or September : this, however, is a mistake, for we are assured that there has been none in the Amsterdam market for more than two months past. No doubt, if the young shoots be regularly cut over, as they appear on the stools, new shoots will of course be put forth during the greater part of the summer, though at the expence of the plants, which are likely to become exhausted and useless. This experiment may be tried, and will succeed equally well in Britain as in Holland. *Sea-calc*, which is so deservedly a favourite with us, does not seem to be known to Dutch horticulturists ; at least, the blanching of it is not understood nor practised.

As far as we could learn, all sorts of culinary vegetables are comparatively cheap in Amsterdam ; and the supply is copious and regular. Those brought from a great distance and kept crowded in almost promiscuous heaps for a length of time, are not perhaps so delicate in flavour as might be wished ;—but the Diemer-mere *moestwijn*s, situate only a short way to the southward of the city, furnish vegetables not liable to such contamination or injury. The Diemer-mere was, as the name implies, formerly a lake. It now ap-

pears as a large tract of very low land, the surface of which is more than twelve feet under the level of the waters of the Amstel or the Zuyder-Zee. It is, of course, protected by a strong dike, and two large mills are continually draining it. In the rich alluvial soil of this artificial valley, culinary vegetables in general are successfully cultivated. Many kitchen-gardeners have established themselves here; and these have procured a separate green-market in Amsterdam to be set apart for their use.

Fruit-Market, &c.

In the forenoon we inspected the fruit-market, and the shops and stalls where fruit was displayed. The supply is inferior to what we should have expected in such a city, and at the time of the fair. *Peaches* were pretty common, particularly the variety called the Mountain Peach: this is a fine melting fruit, and though here regarded as the same with the French Montagne, we are inclined to consider it as different, and of superior quality. A small variety of *nectarine*, of an intense purple colour, appeared in some shops: it is here called the Black Nectarine, and we believe is held in esteem. Both these fruits may deserve the future attention of the Society. *Orange apricots* were pretty common, but not good. Of *plums*, besides the green-gage, we saw only some of the most common yellow kinds. A few baskets of *mulberries* close the list of the finer fruits. Of early *pears* there was a considerable show: the large Cuisse-Madame (which seems identical with our Jargonelle) was going out of season, but still it was among the best on the stalls. The Fig-pear, which we had seen at Haarlem nurseries, was now brought to market: it is a large fruit, and, when ripe, is said to be of excellent flavour; but it keeps only a very short time. *Apples* were plentiful, but in general far from

being ripe. The "Somer wyn-appel" only may here be noticed. It probably receives its name from its vinous flavour: it is a large pale-coloured fruit, altogether different from the red wine-apple mentioned as occurring at Delft, (p. 142.) Some gleanings of the large Dutch white *currant* still remained. There were *grapes*, but they were not ripe, with the exception perhaps of a few berries on each bunch; and it is a fact, that we have not yet seen a bunch of properly ripened grapes on the Continent, at least in a fruit-shop, or for sale. Near the Exchange, we cheapened some blue Frankendales, which were charged at the rate of about 12s. English a pound! and this, we learned, was the usual price at this season of the year, especially when grapes are scarce, as they now are, and enhanced perhaps by the demand occasioned by the kermis. Messina *oranges* were sold at several of the shops: they were of a large size, but neither juicy nor well-flavoured; and yet, like the grapes, they were extravagantly dear. *Gurkens*, or small cucumbers for pickling, were common on the fruit-stalls, but not very good. All kinds of fruit are in general sold by weight by the retail dealers,—a practice which has of late years become common at Edinburgh.

Supply of Winter-Fruit.

The slight notices which we could pick up regarding this subject, need not be omitted. The consumption of winter-fruit in Amsterdam is, we believe, great. Besides what is furnished by the orchards of Guelderland, a good deal is brought down the Rhine from Germany, particularly apples. Among these, the Gravenstein and Borsdorfer are held in high estimation, and deserve more particular notice.

The *Gravenstein* is a large fruit, of a yellow hue, with some markings of red. The pulp is not very tender, but abounds with juice of a rich flavour. If gathered shortly before being fully ripe, it keeps plump throughout the winter; and, we are told, it is frequently dried and stored in the manner of the Foppen-pear, mentioned at p. 191. We recollect that the *Gravenstein* was strongly recommended to the attention of the Horticultural Society by a distinguished cultivator, Mr JOHN BOOTH of Flotbeck Nurseries, near Hamburgh, when that gentleman was residing at Edinburgh some years ago. The tree, when on a free stock, is said to grow to a large size, and to bear abundantly*.

The *Borsdorfer* originated in Saxony, and has for many years been accounted one of the best in that country. There are two varieties. The Common or Autumn *Borsdorfer*, when ripe, is of a yellowish colour, with a little red on one side; the flavour pleasant, and the juice plentiful and sweet; of a middling size, seldom exceeding that of the *Balgone Pippin*. The other variety is called the Red or Winter *Borsdorfer*; it is red on one side, and dotted with red on the other; the pulp white, but reddish at the

* Trees of this excellent variety of apple have since been imported from Hamburgh by DUNCAN COWAN, Esq. a zealous amateur horticulturist, who at present occupies the ancient garden at Edinburgh which belonged to the Regent Murray in the middle of the 16th century, and which is still the property of the Noble Family of Moray. This garden contains some pear-trees of venerable age, particularly *Longuevilles*, *Achans*, and *Jargonelles*, (not our modern *jargonelle*, but the pear which has long been known in France under that name). Here may likewise be seen a magnificent weeping-thorn tree of great age; and the remains of elm-bowers, which have doubtless in their time sheltered the fair Queen of Scots, but the interwoven boughs of which now appear in the shape of fantastically bent trunks, with "scarce a leaf distinguishing the year."

core, and possessing the other good qualities of the autumn kind. This fruit keeps longer than the former, perhaps till June of the following year; and it continues improving till May. The tree is described as attaining a large size; when on a free stock; the blossom is reported to be hardy, and little liable to injury from spring frosts; and on this account there is seldom any deficiency of crop. If these characters of the tree be correct, it seems peculiarly well suited for the climate of Scotland; and as red fruit has an attractive appearance for the market, the Winter Borsdorfer would probably be found not only a valuable addition to our gardens, but also to our Clydesdale and Carse of Gowrie orchards.

The *Frau-apple* is likewise brought down the Rhine from Germany. It is truly a winter fruit; the size is large, the skin brown, the pulp very hard, but of good flavour: it keeps firm not only over winter, but till July of the following summer.

A small pear called the *Theodore* is much used for stewing in thin syrup. The fruit has little flavour; but the tree is said to be hardy and a great bearer. A friend has told us, that the Theodore pear was presented at table to him in Amsterdam, stewed in butter, and sprinkled with pepper; but that when dressed in this way, it seemed a very disagreeable dish. The most esteemed pear for winter use is the "Winter Suyker (sugar) Peer," and this is said to retain all its good properties till May.

Besides the Foppen-pear, already repeatedly mentioned, another, which is often dried in the oven and stored, is the *Sarazzin* or Blessed Pear of the French. It is of considerable size, and of a brownish-yellow colour. It is really a winter pear, and indeed will keep almost throughout the year. It is also frequently used for stewing in the

fresh state ; and as late as May or June of the following year, it sometimes appears in the dessert.

Having determined to leave Amsterdam next morning, we devoted the rest of this day to a general survey of this singular capital, —built in a salt-marsh, and, as is well known, founded on millions of logs and piles. To save time, we availed ourselves of the aid of a commissioner or valet-de-place. Descriptions of the public buildings and curiosities, much more complete and satisfactory than we could pretend to give, are to be found in different books of travels ; and therefore a few desultory notes only, are here to be expected.

Every one has heard the praises of the *Stadt-House* of Amsterdam ; and we venture to say, that no visitant will ever find his expectations balked, or complain of exaggerated descriptions of this noble building. The difficulty of forming a sufficiently sure foundation for so massive a structure, must have been inconceivably great ; and the distance from which all the materials had to be brought, must have vastly swelled the expence. This grand building was well calculated to convey to the mind of a stranger an exalted idea of the wealth and public spirit of the merchants of Amsterdam. But the glory has departed : this splendid edifice is no longer the *Stadt-House* of the Batavian Republic, but a palace of the King of the Netherlands. It was usurped by King Louis ; and possession is retained by the present Royal Family. At the restoration in 1814, it was, in due form, offered back to the city ; but little faith, we are given to understand, was placed in the sincerity of the tender ; and the burghers and merchants of this emporium of commerce, after rearing a public edifice which has been classed among the wonders of the

world, are now content to hold their municipal councils in apartments comparatively dull, dirty, and incommodious. We could not help remarking, that the open area surrounding the palace is not kept in a neat or even cleanly state; while the spaces in front of private residences in the principal streets are in the trimmest order. The proportional smallness of the main door, and the want of a portico, did not fail to strike us, and immediately recalled to our recollection our having long ago read some just criticisms to that effect. We readily procured admission; and at once pronounced the Marble Hall to be by far the finest public room we had ever beheld. But a detailed description of the interior of the building has been thought worthy of occupying two splendid volumes in folio; and we could add nothing to the abridged accounts to be found in every book descriptive of Holland. The view of Amsterdam from the roof is interesting; here only did we form a correct estimate of the multitude of shipping in the port. Having lately seen the comparatively deserted harbour of Antwerp, we could not help reflecting on one cause of the contrast, and regretting the injustice done to the Brabantines in the closing of the Scheldt. In a tower on the roof is a set of musical bells, the chimes of which are excellent; very superior indeed to those of St Giles's at Edinburgh.

On leaving the Palace, we turned a little to the left, to inspect what is called the *New Church*, but which is in reality an old Gothic building, dedicated in former times to St Mary and St Catherine. The most striking ornament is a monument to the memory of the bold De Ruyter, who once sailed up the Medway, and took temporary possession of Chatham and Rochester (towns through which we had lately passed),—an exploit more daring and

impressive than any which Buonaparte, in the plenitude of his power, and with the most rancorous feeling towards London, was able to effect.

We next proceeded to the principal *Fish-market*, which is situate in the neighbourhood. The most remarkable circumstance here was, that most of the fish were kept alive for sale: not pond-fish merely, but several of the kinds of sea-fish were thus kept in tubs and chests filled with salt-water; among these were haddock, cod, young coalfish, and different species of flounder. Half a dozen of tame storks were walking about, as at the fish-market of the Hague; a small wooden house, for their protection during night, was pointed out to us, and we were told that a person is employed by the Magistrates to look after these sacred birds.

We now perambulated several of the central streets, which are in general narrow, and without the accommodation of a foot-pavement. Sledge-coaches were continually passing along, physicians being almost the only citizens allowed to accelerate their movements by means of wheels. Goats, as well as dogs in harness, drawing either *kruiwagens* full of merchandise, or children's coaches with most sedate-looking inmates, form very prominent foreign figures in the street scenery of Amsterdam. A kind of church-officer dressed in black, with a long crape flowing from his cocked hat, and a paper in his hand, we ascertained to be the *aansprecker* or announcer of deaths; for in this way verbal intimation is made to the acquaintances of persons deceased. Garlands of box were suspended over many doors; and this, we were told, indicated that fresh-herrings were to be procured within.

At length we arrived in a large open area, the most extensive, we believe, in Amsterdam, called the *Boter-markt*,

or Butter-market ; the space being proportioned to the sale of an important article of commerce, and favourite commodity of the inhabitants :

“ Leeks to the Welsh ; to Dutchmen butter’s dear.”

In this arena, all the shows of the fair were now collected, and they had come from several different countries,—panoramas from Flanders, wax-works from Italy, dwarfs and giants from Germany, tumblers, rope-dancers and exhibitors of marionettes from Paris, and, though last, not least in importance among the spectacles, John Bull, with a collection of wild beasts from Exeter Change. On every hand were erected temporary booths for preparing and selling *broodyerties* and *waffles*, which are sorts of small pancakes, eaten with butter and sugar. We visited a panorama of the Battle of Waterloo ; and in this truly Dutch representation of that memorable scene, it was amusing (though perhaps quite excusable in the patriotic artist) to find the Prinz van Oranje sustaining a much more conspicuous and important station and character than either Wellington or Buonaparte.

Having intimated, somewhat to the surprise of our guide, that we would prefer to the exquisite treats of the Butter-market, a sight of the Admiralty and the Dock-yard, he conducted us to the Amstel-Land, where these are situate. We passed a long bridge over the Amstel, consisting of more than thirty arches, eleven of which are of thirty feet span ; three or four, however, at this time sufficed for the water-way. Immediately below the bridge are several regulating sluices ; and from this circumstance the bridge has got the name of the Hooge Sluis. It is constructed partly of brick, and partly of hewn-stone, and has iron balustrades on each side. We found none of that difficulty in gaining admission to the government premisses

which strangers would certainly encounter at Plymouth or Portsmouth. We walked through the extensive warehouses, and into the dock-yard, where several sloops of war and one line-of-battle ship were on the stocks. Even the model-room was thrown open to us. Here the model of the *camel*, by means of which ships of the line are enabled to get over the Pampus or bar of the Zuyder-Zee, was explained to us. It consists of two long vessels like barges, but without hatchways, and connected below by strong chains: water being admitted, the camel sinks and is then passed under the bottom of the war-ship; the water being now pumped out of the camel, its buoyancy is so great that it raises the ship a good many feet, and enables her to pass the bar. The officer in attendance was evidently not ill pleased to be able to shew us as a trophy, a letter written by James, Duke of York, as Governor of the East India Company, in 1664, addressed to an Indian Prince, and which, from the contents, appears to have been accompanied with the present of a crown; the English vessel conveying the present having been captured by Admiral De Ruyter.

Close by is the marine seminary, called the *Kweek-school*, for the instruction of boys in naval matters. There is here a large model of a frigate, equal in size to an ordinary sloop, completely rigged and fitted out; by means of which the young men learn the names and management of the multitudinous tackle and sails of a war-vessel. The scholars wear a uniform, sleep in hammocks, mount guard, and are altogether under the same discipline as if they were at sea.

We proceeded to view the harbour, and to pay cursory visits to some of the many public establishments. In the street next to the harbour, are some elegant houses; but

none superior to those of the Boompjes of Rotterdam. The houses possessed by the French douaniers, which were gutted at the commencement of the revolution in 1814, still remain in a dismal state of ruin. The innocent Dutch proprietors of these houses (one of them a widow lady) have not hitherto, according to our information, received any compensation from the new government.—In the harbour a *slyk-mill**, or dredging machine, was at work. This is a large square vessel, on board of which two horses are employed in turning two wheels; these are connected with a train of scoop buckets, which sweep the bottom, and then deliver their slimy contents into reservoirs.

The quays and warehouses of the East India Company, and also of the West India Company, had in former times been respectable, and even yet they excite the admiration of French and especially of German visitants; but they sink into insignificance when compared with corresponding establishments on the Thames. Several of the streets are adorned with rows of fine trees, chiefly elm, lime, and walnut; but there are here no splendid airy squares nor circuses, as in London and Edinburgh. In one place only there is a curvature, approaching in character to our crescents: it is called the *Bogt* †, and contains some of the best houses in Amsterdam.

We found it necessary to visit Hope's Bank, in order to recruit our finances. We could procure no gold; but received rix-dalders and dalders, and were presented with small bags to carry them in ‡.

* *Sleck*, it may be remarked, is the common Scottish word for *sludge*.

† Pronounced like our Scottish *boucht* or *bught*, and evidently the same word.

‡ As the Dutch coins are numerous, and rather embarrassing to strangers, we shall mention those which we found to be most generally in circu-

In the Museum of Paintings, we saw several very large pieces, by celebrated Dutch masters, which had formerly graced the walls of the Stadt-House, but had been dismissed from the Palace; particularly the night-watch of Amsterdam by Rembrandt, and a party pledging each other in a friendly cup after concluding the treaty of Munster, by Van der Helst: this last, our conductor mentioned (and we believe correctly), was highly praised by Sir Joshua Reynolds. A night-school, by Gerard Douw, is remarkable for exhibiting correctly and beautifully the effects of several different lights, on the youthful and homely faces of the scholars: this picture, we were told, was valued at 20,000 florins.

In the Kiesergragt is a large and rather handsome edifice, with columns of the Corinthian order; but the words *Felix Meritis* under the pediment, in large gilt letters, do not produce a happy effect. This is the title of a public establishment, which, in some respects, resembles in principle the Society of Arts in the Adelphi, London: meritorious artists and others being rewarded for their discoveries and

lation. To begin with the lowest:—the *Doyt* (formerly well known in Scotland) is a trifling copper coin, equal to half a farthing nearly. The *Stiver* is a small thin coin, of base metal, resembling silver, = a penny, or little more. The *Doubletje*, also of base metal, is double the stiver, or = 2d. The *Sest-half*, of base metal, is a good deal larger than our sixpence, but only equal to 5d. in value. The *Schelling* is like the sest-half, but has an asterisk impressed on it, = 6d. The *Guilder* or *Florin*, of good silver, is equal to 20 stivers, or 1s. 8d. nearly: this is the most common silver coin, and generally used as the standard of value. The *Dalder*, or 30 stiver piece, = half a crown, is also a common coin. The *Rix-dalder* or dollar, = 52 stivers, or is 4s. 4d. likewise very frequent. Besides these, a 13 stiver piece, a 28 stiver piece, and a 3 guilder piece, occasionally occur. The Dutch coinage seems at present in a very debased and imperfect state, worse than the English was before the year 1816.

improvements; while ladies attend the public meetings, and witness the distribution of honours. But the building is made to answer various other purposes. It contains the Concert-Hall of Amsterdam, and also an amphitheatre for lectures on natural philosophy and chemistry. Dutch taste, strongly influenced by habits of business, here shows itself in rather an amusing way: a principal ornament of St Cecilia's hall is a clock to warn the audience of the passing hours, and in the amphitheatre there is an index which announces to the merchant every variation of the wind. Other apartments in the same building answer the purposes of our academies for painting and statuary; and, to crown all, there is an observatory on the roof.

The *Exchange* is one of the most remarkable places in Amsterdam. As a building, it is perhaps nowise superior to that of London; but from two to three o'clock it is crowded with merchants and traders from all countries, in a manner that seemed quite extraordinary to Scotsmen, who were accustomed to see only the trifling weekly assemblage at the Cross of Edinburgh.

Close by, in the Kalverstraat, is an institution having for its title *Doctrinâ et Amicitia*. The library and museum is much frequented by the merchants as they leave 'Change: here they are provided not only with newspapers, but with all the best periodical publications of Germany, France, England, and Italy; and they really come to read, for the strictest silence is observed. Above is a large hall for the general meetings of the Society; where some of the most distinguished literary names which Holland can boast are blazoned on the wall. *Grotius* is inscribed at the head of the room; and along the sides are the names of *s'Gravesande* the philosopher, *Boerhaave* the physician, *Vondel*

the poet, *Hooft* the Dutch Tacitus, *Bynkershoek* their Blackstone, and *Burman* their “coryphæus of letters.”

Kalverstraat is the Bond Street of Amsterdam, abounding with shops for the sale of jewellery, china and crystal wares, mirrors, paintings, prints and books. The street is narrow, but the shops are elegant, and most richly furnished with goods.

There is still another society, with a Latin title in the ablative absolute,—*Concordiâ et Libertate*. It seems to resemble our Edinburgh Speculative Society; every one in his turn reading an essay or oppugning it, and such other members as choose taking part in the debate.

We had only a passing view of the *Rasp-Huys*, a kind of Bridewell, so called from the circumstance of the inmates being chiefly occupied in rasping Brazil-wood and log-wood for dyers. The entrance is ornamented with some well executed pieces of sculpture in bas relief, representing various wild animals in harness.—The *Spin-Huys* is a sort of work-house for persons guilty of minor offences; and it also serves as a house of refuge for the destitute.

But we are probably wandering too far from the proper subject of this volume; and hasten to return, by taking some notice of the utility of Dutch ashes in gardening. A few words may first be said regarding the fuel from which the ashes are produced.

Fuel.

Holland is necessarily destitute of mines and minerals. The merchants supply metals in abundance, but the carriage of coals from Newcastle or the Frith of Forth, is found too expensive, to permit of their being generally used. Without coals, and without copse-woods, the Dutch

have to depend on their *veen** or peat-mosses for fuel. There are two kinds of these, the higher and the lower. The high mosses afford a layer of what is called grey or dry peat, and the subsoil afterwards forms arable land. The low mosses afford what are called mud-peats, and these are often taken from the second or inferior layer of such moss; when this is the case, the excavation speedily becomes covered with water. When the under stratum of moss is firm and contains wood, it is called *derry*. Many trunks of trees are found in it; and these uniformly lie with their heads pointing eastward, showing that the storm or debacle which overwhelmed them had come from the west. Some of the timber, oak in particular, remains sound, so that it can be used in carpentry; but it is of a dark colour, as if stained with ink. There is a law against digging through this *derry* in the lowest parts of the country, much water being found to ooze in the sand below, and to be repressed by the compact layer of wood-moss. Metelerkamp, in his Statistics of Holland, estimates, that eight millions of tons of grey or dry peats are annually prepared, and half that quantity of the muddy kind. In genteel houses, billets of wood are frequently added to the fire; and coals are used on particular occasions.

Dutch Ashes

are in great request by the industrious farmers around Ghent, and in other parts of Flanders, proving to them a very useful manure. So far as we could learn, they are little used in Holland itself; but they are carefully collected and sent by water to the Flemish agriculturists, and at very reasonable prices. As might be ex-

* *Veen* is pronounced like *fen*, and is evidently the same word.

pected, Amsterdam produces by far the largest quantity: Messrs Sielring and Vander Aa of this city, are the principal dealers. They have a lease of all the ashes of the capital, and likewise of those of the neighbouring towns. In Amsterdam they have 80 carts and horses, and as many men, daily employed in collecting the ashes. These are carefully kept separate from the street manure, and stored under long shades on one of the quays, where they lie ready for exportation.

For information regarding the employment and utility of these ashes in agriculture, we may refer to the publications of Sir John Sinclair and Mr Radcliffe. It is our business here to add, that they are also found useful in horticulture. M. De Wulf of Ghent (mentioned *suprà*, p. 67.) particularly recommends their use both in the garden and orchard. He observes, however, that they should not be laid on the borders very recently after being taken from the fire, for in that case they would prove injurious; but that, after being kept for a short time, and if they be applied in small quantity, they never fail to produce the best effects. Mr De Wulf particularly mentions, that fruit trees in a languishing state in his garden, have been restored to vigour by the application of ashes. He considers, that they not only tend to open the soil, and to stimulate it (*l'échauffer*), but also assist in affording additional nourishment to the plants, by means of the water which they absorb and gradually give out; and that by carrying into the soil principles calculated to attract the carbonic acid of the atmosphere, the solubility of the portions adapted for the food of plants is promoted. If no rain or dew fall soon after the application, slight waterings from the rose of a watering-pot are proper. When ashes are old, or have been long kept, they may be spread

on the garden in greater quantity : they then not only help to keep the surface of the soil damp (an object of great importance in a light sandy soil, and under a hot sun), but attract and preserve much carbonic acid. When old garden soils are overloaded with rich mould (*terreau*), or where too frequent manurings have been given for a series of years, stale ashes are found the best restorative of the soil to a due state of sharpness and activity.

Water.

That fuel should be rather scarce and dear at Amsterdam, might be expected ; but, surrounded and intersected by canals as the city is, it seems odd that another of the necessaries of life, *pure water*, should be a still scarcer commodity. Yet such is the case. There is no water fit for culinary purposes but what is brought by boats from the Vecht, a distance of fifteen miles ; and limpid water from Utrecht, more than twice that distance, is now sold in the streets by gallon measures, for table use, and for making of tea and coffee.

In taking leave of Amsterdam, we may remark, that an amusing and lively account of this capital, its public institutions, society, painters, &c. may be found in a small volume, entitled, "*Voyage par la Hollande*," published by a French visitant in 1806. This is probably the most recent sketch of Amsterdam. But, with the exception of the conversion of the Stadt-House into a King's Palace, and the establishment of the Societies above mentioned, its general aspect and character have undergone little change for a century past ; insomuch that "*Le Guide d'Amsterdam*," published by Paul Blad in 1720, may be regarded as forming a correct and useful pocket-companion at the

present day. It may indeed be added, that, so far as we have had an opportunity of observing, the descriptions given of the Dutch towns by Mr Ray in 1663, Dr Brown in 1668, Mr Misson in 1687, and Dr Northleigh in 1702, are applicable in almost every particular to the same towns at the present day; so comparatively stationary has Holland been, or so averse are the people to changes.

Amsterdam to Utrecht.

Sept. 3.—On account of the advanced season of the year, we relinquished the plan of going through North Holland, that we might have more time to spend in horticultural investigations at Brussels and Paris. We even sacrificed our fond desire to see Zaardem and Broek, a visit which we could have accomplished in a day. We determined therefore, immediately to diverge to the south-east, and to content ourselves with viewing Utrecht and Breda.

Before 6 A. M. we procured a coach with wheels to convey us to the Beerebyt Inn, on the banks of the Amstel, from which the treckschuyt for Utrecht sets off at that timeous hour. Instead of being assailed by beggars, as at Ghent on a similar occasion, we found ourselves among a crowd of contented and happy looking persons, many of whom seemed to have no other business but to witness the departure of the barge. The morning was delightful, and the changing scenery on the banks of the river afforded us no little pleasure.

The common reed (*Arundo phragmites*) is extremely abundant on the margins. It is mown several times during the early part of summer for hay, forming, we should think, a very coarse article of that kind. It is afterwards allowed to grow up, and is cut at the approach of winter. The panicles of flowers being thus retarded, are still un-

ripe and firm; and are much used for making hearth-besoms. The stems are employed for thatching barns, and for lining the exterior of the wooden walls of out-houses of different descriptions. This valuable reed is likewise used for covering the numerous small stacks of peats for winter fuel, which are every where to be seen; and for forming roofs to the equally numerous hay-stacks for winter fodder for horses and cows. In this country, the hay-stack is generally provided with a permanent thatched-roof, supported on posts; which is probably a necessary precaution in a moist climate, and where the hay is saved in small parcels at intervals. The reed is likewise used in horticulture, for making screens or *brise-vents*, which are found more durable than those of straw. And it is, lastly, employed in forming hassocks for the churches.

The river takes a gently winding course, and affords different favourable views of Amsterdam, as we recede from the city. The meadows, on both sides, are commonly five or six feet below the level of the river. Some villas begin to appear, of larger dimensions than those immediately adjoining to the city, and surrounded with double and triple rows of tall trees. These belong either to retired merchants, or to capitalists who live on their money, here known by the name of *renteeners*.

After passing the smiling village of Ouderkerke, we got a view of the ruinous Castle of Abkoude. Only a round tower and some strong outer walls now remain: they are all built of brick, but are evidently of great antiquity. The helms-man gave us to understand, that the Castle was destroyed in the time of the Spanish wars, when the States were asserting their independence. He expressed this with an air of reading and intelligence, not to be observed among the boatmen of the Thames or the bargemen of Flanders,

and characteristic only of a Scots pilot or a Dutch skipper. The margins of the canal in several places abounded with the water-soldier (*Stratiotes aloides*), and narrow-leaved reed-mace (*Typha angustifolia*). The poisonous water-hemlock (*Cicuta virosa*) was very common. The deleterious effects of this plant on cows which browse it, have sometimes been experienced at Lochend, in the neighbourhood of Edinburgh, where it is not nearly so abundant as here. It seems surprising that it is not carefully extirpated by the Dutch; for, in general, they pay the greatest attention to the welfare of their cows.

At a neat little fort called Nieuwer Sluis, we left the Amstel and proceeded on the river Vecht. A single lock occurs here, raising the level three or four feet. Some extensive and elegant villas now presented themselves, and we thought we could discern attempts to approach the English style. A large paddock supplies the place of the park; and groves of lofty trees, contrasted with thickets of shrubs, make up for the want of variety of surface. Some sweeping bends of the Vecht are highly favourable for promoting picturesque effect. The white willow forms a very general and appropriate ornament on the banks, and its light foliage is well relieved by dense belt-rows of Dutch elm. We afterwards came to Maarsem, a considerable village, inhabited, we understood, almost exclusively by families of Portuguese Jews.

As we approached Utrecht, the banks of the canal began to acquire elevation, and the gardens to appear above, instead of below the level of the water. A green line of *conferva* informed us, that, even at this distance from the sea, the water of this canal rises and falls with the tide.

UTRECHT.

About 2 o'clock in the afternoon we reached this ancient place, and proceeded to the Chateau d'Anvers, or Antwerp Arms. This inn is still kept by a grandson of old Oblet, who used to boast to English travellers of having frequently been host to the Marquis of Granby, during the war of 1756. There is a freshness and coolness about Utrecht, which is rendered more striking to those who have recently been annoyed by the sickening fetor of the canals and the feverish heat of the streets of the Dutch capital. We were well pleased to be able again to breathe untainted air, and to enjoy the luxury of pure water.

Botanic Garden.

We spent the afternoon chiefly in viewing the Botanic Garden, which, though small, contains a tolerably good collection of plants. Here we met Dr Van Gunst, the present Professor of Botany; and were much taken with the simple and venerable appearance of the superintendant of the garden, Mr Frederick Lichtervahl, who, finding that we were horticulturists, expatiated on the pleasantness and healthfulness of the gardener's life, and mentioned that he had yesterday completed his 82d year. He is a Prussian, a native of Potsdam.

The range of hot-houses, or stoves for tropical plants, measures about 124 feet in length; and there are two green-houses, one 60, and another 42 feet long. Besides these, there is a long suite of pits, 80 feet in length, covered with glass frames, chiefly for preserving plants during winter. The stove plants appeared to us to have suffered from the contracted form of the houses, being drawn up, and in some

instances sickly. The fault consists principally in the narrowness of the houses, and in the want of sufficient light and air.

There are here four large plants of the Dwarf-palm (*Chamærops humilis*), a species which has already been mentioned when speaking of Leyden. One of these, M. Lichtervahl told us, has existed in the garden ever since the foundation of the Academicum in 1630. It is now about ten feet high, and two feet and a half in circumference where thickest. It has repeatedly flowered in Mr Lichtervahl's time, and produced male blossoms. A female plant was pointed out to us, which produced its flowers and fruit two years ago: it is more than 150 years old, and the root bears testimony to considerable age, the upper part appearing for more than a foot above the ground. Two specimens of the Banana-tree (*Musa sapientum*) were rather in an interesting state: the one was coming in flower, while the other presented the fruit of last year.

Some of the larger and hardier inhabitants of the greenhouse, are likewise plants of reverend aspect, which must have seen generations pass away; particularly a Sweet-bay (*Laurus nobilis*), an Andrachne (*Arbutus Andrachne*), a Mastick-tree (*Pistacia Lentiscus*), and a double-flowering Pomegranate (*Punica Granatum*, fl. pl.). These endure the ordinary winters of England, and would probably withstand those of Utrecht; but they are planted in strong tubs, and housed during winter, having been originally brought to the garden when such plants were scarce and newly introduced into the north of Europe.

The medical plants occupy a separate quarter of the garden; and the gramina are placed together: but we did not observe any other attempts at arrangement. We looked in vain for a Jussieuan or a Linnean collection.

Among the hardy trees may be noticed a very tall Ginkgo, the tallest, though not the handsomest, we have seen. The *Edwardsia grandiflora* of New Zealand, seems here to flourish against a wall in the open border; and several specimens of the Gold Plant of Japan (*Aucuba Japonica*) have acquired so large a size, being not less than ten feet high, as to leave little doubt of their being nearly coeval with the original plants sent home by Thunberg.

The fund for the support of the garden being slender and inadequate, plants and seeds are occasionally disposed of, with the view of increasing its amount. But no catalogue of the plants has been published.

It was now the time of vacation, and little was to be seen within the walls of the Academicum. In one apartment is kept a model of the Sacred Temple reared by Solomon, formed precisely according to the description contained in the First Book of Kings, on the scale of an inch to the yard. This piece of laborious trifling occupied a former learned Professor of Oriental Languages (Mill), for six long years. The room destined for it, admits only one half of the model to be displayed.

The students have no apartments within the college pomeria, but lodge and board themselves with the inhabitants of the town, as at our Scottish Universities. As a proof that foreigners frequently resort thither, we may mention, that the notice of a "room to let" is here given in Latin, "*Cubiculum locandum.*"

The Mall

being in the neighbourhood of the University buildings, we walked into it. This Mall has been celebrated for its trees, ever since the days of Louis XIV., who took Utrecht in summer 1672, and remained here several months. That

capricious monarch respected the fine avenues, and only expressed a wish that he could transfer the trees to Versailles. There are eight distinct rows of trees, chiefly limes, elms, and oaks, with walks, neatly laid with gravel and shells. Though the walks are broad, they are yet shady, on account of the loftiness of the trees. In one or two places are smooth lawns, still suited to the game of mall, which, however, has ceased to be a favourite pastime. The Mall is subrounded by a carriage-road, likewise skirted with trees; and riding or driving along this is now the fashionable amusement. At the upper end of the Mall, in a beautiful situation, is a handsome public building, of large dimensions. This was formerly appropriated to the residence of the Professors of the University; but Buonaparte ordered it to be converted into barracks! This was not quite consonant to his professions, nor indeed to his usual practice, in regard to seminaries of learning. But it is somewhat strange, that to this base purpose the building is still applied under the restored government, which ought certainly to have shown more respect to the Professors of the ancient school of Ultrajectum.

Palace of Utrecht.

Although Louis Buonaparte built no palace, yet he contrived amply to gratify his taste for the possession of royal mansions. We have already seen two edifices which he set apart for royalty in Holland,—the Pavilion at Haarlem, and the Stadt-House of Amsterdam. The palace-loving Prince could not choose but have a summer residence at Utrecht, where the ground rises, the water is pure, and the air clear; but this Utrecht palace, we believe, was come at in a more honourable way than the other two. It is quite a plain building, and merely forms

a part of one of the streets. All of these additional palaces are maintained by the Orange Family, who thus, we should think imprudently, identify themselves, in such matters, with the late government.

Dutch Garden in the Old Style.

Sept. 4.—This morning we paid a visit to the *Zyde-baan* or silk-manufactory of Mr Seterveldt, beyond the Amsterdam gate, on the banks of the canal by which we yesterday entered Utrecht. According to the best information we could procure, Mr Seterveldt's garden, immediately adjoining the manufactory, affords the most characteristic specimen now remaining in Holland of the old style of gardening, which was in so high repute two centuries ago, and which, with some modifications, continued in vogue among the Dutch till within the last forty years. This old garden was the principal object of our curiosity; but we were first invited to inspect the manufactory. Our guide informed us, that the owner resides at Amsterdam, and added in a whisper, that the silk-business goes on very dully. As far, indeed, as we could observe, the only employment for the extensive machinery at this time, was the throwing of some unbleached silk for officers' epaulets.

On entering the grounds, we found that, though rather narrow, yet they stretched out to a considerable length, and were sufficiently extensive, to obviate the common, and in Holland generally well founded, reproach of scanty limits; but we were disappointed on perceiving that they were not kept in that trim order for which Dutch gardens are usually remarkable. The large divisions of the garden are made by tall and thick hedges of beech, hornbeam and oak, variously shaped, having been tied to frames, and thus trained, with the aid of the shears, to the desired form. The smaller

divisions are made by hedges of yew and box, which in thickness and density resemble walls of brick.

Grottoes and fountains are some of the principal ornaments. The *grottoes* are adorned with masses of calcareous tuff, corals, and shells, some of them apparently from the East Indies, others natives of our own seas. The principal grotto is large, and studded with thousands of crystals and shells; we were told that its construction was the labour of twelve years. The *fountains* are of various devices; and, though old, some of them were still capable of being put in action. One, in which the water is discharged upwards in a continued circular stream, hollow in the middle, had a very pretty effect. Frogs and lizards, placed at the edgings of the walks, and spouting water, to the risk of passengers, were not quite so agreeable; and other figures were in still worse taste.

There is a long berceau walk of beech, with numerous windows or openings in the leafy side-wall, and many statues and busts, chiefly of Italian marble, some of them of exquisite workmanship. Several large urns and vases certainly do honour to the sculptor: the subjects of the bass-relief ornaments are the histories of Saul and David, and of Esther and Ahasuerus. Having mentioned to the attendant, that in England such pieces of sculpture would bring more than a hundred guineas each, we were immediately told, that Mr Hope of Amsterdam had offered to purchase, at a high price, two of the more recent, cut in Carrara marble (as the pedestals bear) by "Jacob Cresant, 1738;" but that the owner replied, that the place having descended from his father and grandfather, it should pass down to his children unimpaired by him. With this becoming resolution we more cordially sympathised, when we observed, hard by, a simple monument erected in me-

mory of one of the family who had died in the flower of youth. The emblems were affecting: in one place a tulip (the favourite flower in Holland) broken over, with an inscription alluding to the uncertainty of life;—in another place, the same plant again springing up, intimating the cheering hope of the resurrection.

There are several avenue-walks, which meet at central points. There are likewise some fine vistas; one, closing with an obelisk; another, in better and more ambitious taste, terminating with the tower of the great church of Utrecht; and a third, leading the curious eye to lose itself in the rich and extensive champaign.

Stretching across a canal, and opposite to each other, are two verdant houses, consisting of beech-trees, the outer trees being trained and cut like gable-walls. These had, to our eyes, a very odd appearance, and they produced no pleasing effect.

We were struck with this circumstance, that every thing in this garden has its most exact counterpart: if there be a pond, a walk, or statue, or a group of evergreens on one side; the same may, with confidence, be predicted on the other side of the garden;—so that the often-quoted couplet of Pope can nowhere be more literally exemplified:

“ Grove nods at grove; each alley has its brother,
“ And half the platform just reflects the other.”

The two corresponding ponds are surrounded with very old horse-chesnut trees (*Æsculus Hippocastanum*), probably among the oldest in Holland, this tree having been one of those introduced by Clusius. At the extremity of the garden is a large circular walk, completely shaded with beech-trees; and having a piece of water in the centre of it. The ponds and this sheet of water abound with fish, particularly carp.

The greenhouse is quite in the old style: it is richly ornamented in front, and the interior is much more commodious for ladies and gentlemen than for plants. The inside of the walls has been painted with landscape-scenes in a kind of fresco, and the floor is laid with imitation mosaic work. The house measures about fifty feet in length; and it has two antichambers for company, each twenty feet long.

Adjoining the garden is an inclosed menagerie for various sorts of animals, and in particular for birds. At present the whole is in disrepair, and untenanted. Close by is a fish-pond lined with masonry, and with flights of steps descending to the water in every direction. Here, then, we were gratified at once with the view of specimens of the *vivarium*, the *volary* and the *piscina* of the 17th century.

The fruit-garden is immediately connected with the ornamental grounds. There is here a wall with numerous curved recesses, intended for the training of the more tender fruit-trees. At present, this wall is wholly occupied by apricot-trees; one being placed in the centre of each curve. The curves having a radius of four feet and a half only, are evidently too small to afford protection to such trees from sweeping blasts. Probably they had originally been appropriated to grape-vines. In this garden there is likewise a *wooden wall*, to which the branches of some aged vines are trained. These, we were told, often yield large crops; but, this season, the bunches are scanty, and are so backward that we should think they can scarcely ripen before winter. Some good specimens of dwarf apple-trees appeared, trained in the arbornijn style; these "leafy punch-bowls," as they have not unaptly been termed, were here quite in character. We remarked a bed of celeriac seedling-plants, which

the gardener informed us are to be planted out within a fortnight: the stems swell so fast in this mild and moist climate, and porous soil, that we were assured they would be ready for use by the end of November.

We left Mr Seterveldt's with a conviction that we had seen probably the best specimen now remaining of the true old Dutch style of gardening, of which we had read so much in books, but of which no proper example had hitherto occurred in our peregrinations through South Holland: and we here enjoyed the advantage of seeing not only striking remains of the more ancient style of the 17th century, but perfect specimens of the taste which prevailed about eighty years ago, when (as we learned) Mr Seterveldt's place was restored, enlarged, and embellished. This somewhat lessened our regret at losing a sight of Broeck and Alkmaar, where, we believe, this formal style is yet preserved, with all the tidiness of modern neatness.

Ziest.

Having hired a carriage, we set off for Ziest, about seven miles distant, thus procuring a general view of the nature of this part of the country. Ziest was once a hunting-place of William the Third, and afterwards became the seat of Count Zinzendorf, by whom it was given to the Society of Moravians. In the groves, walks and canals which surround it, many marks remain of the former beauty and grandeur of the place. Some of the beauty, perhaps, still continues, but the grandeur is extinguished, the buildings erected by the United Brethren resembling some great English manufactory. A beech hedge about thirty feet high, and in the most perfect state of health, could not fail to impress us with a favourable opinion of the soil and climate. Having never seen a Moravian settlement, we rung

the door-bell, and entered: various successive warerooms or shops were thrown open to us, and by purchasing a few trifling articles (which, by the by, were chiefly of English manufacture), we gave perfect satisfaction to the brother who took the trouble of conducting us.—The sisters all dwell apart. The unmarried women wear a red ribbon round the neck; the married, a blue ribbon; the widows, a white one. It was now the dinner hour, and all work was suspended. We received permission to walk every where through the gardens and shrubberies. As we approached a canal, we happened to surprise some of the younger sisters while amusing themselves in sculling a boat; they were making noise enough with their merriment, and were probably the romps of the sisterhood: the unexpected interview only increased their hilarity, while they paddled off to their own quarters. In such establishments, all is held in common; or rather, all profits pass into the pocket of the governor, who disburses for the general behoof, and on whom the good of the body is considered as depending. When a marriage is agreed on, a separate house is provided for the couple. They bring up and educate their children, till they be fifteen years old, when they are invariably dispersed to other Moravian settlements at a distance, almost all intercourse between the parents and children then ceasing.—The Ziest Brethren have not spared either pains or expence in making an excellent road to Utrecht; and, by the facility of communication thus afforded, they have greatly increased the resort of visitants to their establishment.

The Dôme.

Utrecht was an episcopal see for 700 years before the Reformation. On our return to town, we visited the an-

cient cathedral church, and ascended the truly lofty tower or steeple, which is termed the Dôme *.

The belfryman and his family inhabit some apartments situate about half-way up. Here we were courteously invited to rest ourselves, in a small neat parlour, the window of which commanded a most delightful prospect; and we were presented with a telescope, to view distant objects. With the aid of this, we could perceive the towers of Nimmegen in the south-west. As far up as the belfryman's house, the ivy-leaved Snapdragon (*Linaria Cymbalaria*) was growing from all the outer crevices of the wall, and it was now hanging in long tufts full of flowers. When we reached the top, after having ascended 460 steps, the view became very extensive: we saw distinctly twenty-four miles in every direction around: our view to the westward, indeed, which was now clear, was terminated only by the gently swelling hills of the principality of Cleves. Marmont's Mount or earthen pyramid was a very conspicuous object, in the north-west. The bellman told us, that he had been at it, and that he considered it as of equal height with the steeple on which we now stood: in this estimate, however, we are sure he is mistaken: it is probably about one-half, or 150 feet high, including the column which stands on the top of the pyramid of earth. General Marmont had the command of many thousand French and Dutch soldiers, who were encamped at the place for several years; and this vast Mount, was reared in honour of Napoleon, upon his assuming the imperial dignity. The upper part of the walls of the Dôme are strangely rent, the injury having been probably occasioned by lightning: they have been in the same state beyond the memory of

* From the Italian, *duomo*, cathedral,

man, and although they may possibly hang together for centuries to come, yet it is not easy to divest one's-self of the idea of insecurity, in a shattered steeple constructed of brick.

Flora's Hof.

We next paid a visit to the Garden of Flora, belonging to Messrs Van Lunteren, who have long been established as florists and nurserymen at this place. Considered as a sale collection in a provincial town, this nursery-garden is respectable. One of the partners pointed out what were considered as rarities, and readily answered such inquiries as we made. Besides showy herbaceous plants, there is a considerable collection of ornamental shrubs and forest-trees, with a catalogue of which we were presented*. There is likewise a small assortment of fruit-trees of various kinds. Our attention was principally attracted by the *Calebasse* pear, already mentioned as occurring at Bruges, p. 31. It evidently receives its name from resembling in shape a bottle-gourd. In size it nearly equals our jargonelle; the skin, however, is not green, but of a greyish hue. It is an early autumn fruit, some specimens being now almost ripe. It has a firm but juicy pulp, with a good deal of flavour. It possesses this superiority over most summer pears, that it continues in season for about two months. The tree grows vigorously when grafted on a free stock, and trained as a standard: and we are told that it seldom fails to yield an abundant crop. This is evidently a distinct variety of pear, of recent origin, and not yet known at Edinburgh. It seems highly worthy of introduction, and of the attention of the Society.

* "Catalogus van in den open grond overwinterende Boomen en Heesters, welke te bekomen zijn bij H. en D. van Lunteren, bloemisten en boomkwekers in Flora's Hof te Utrecht."

It may be proper to give it the protection of a wall in Scotland. Mr Lunteren mentioned to us, that he is possessed of two sub-varieties of calebasse; but we did not see them in fruit. The *Persique* pear was described as being delicious when ripe, but it is not ready till the beginning of November, and it keeps only for about a month. The *Fig-pear* (already noticed, p. 224.) was nearly ripe: Mr Lunteren praised its good qualities, and, on our hinting at its supposed aptitude to rot, he denied that this was the case, and observed that it kept good for several weeks. The *Poire Madame* was extolled; and, on its being shown to us, we recognised (as we expected) our jargonelle. The *Wyn-pear* is early ripe; and, like others of that class, it speedily begins to decay. The *permain pipling* (pippin) and *Konings pipling* were mentioned as among the best apples here. Different varieties of *Calvilles* were likewise pointed out to us as dessert apples,—such, however, as would scarcely be admitted to our tables in Scotland. Mr Lunteren had not heard of any new apple or pear of fine qualities having been raised from the seed, in this part of Holland, for the last thirty years. Novelties of this sort are chiefly derived from the neighbourhood of Brussels and Tournay.

A wall was pretty well clothed with healthy vines, which shewed a few bunches of grapes. The blue *Frankendaalder*, early white *Vanderland*, and white *Parel Druyf*, were the kinds most in esteem.

We concluded our day at Utrecht with a pilgrimage through the town, to the *Buur-kerk* or English Church, —and to the birth-place of Adrian the Sixth, one of the best of the Pontiffs,—and of Maria Schuurmans, the Mary Wollstoncroft of Holland; returning homewards along the

ramparts. On one side, the ramparts formerly afforded a delightful promenade, being shaded with a double row of lofty lime-trees, on which numerous nightingales used to perch and sing during the early part of summer, while the view of the circumjacent country on the open side was rich and extensive. These lime-trees were held sacred by Louis XIV.; but the ruthless Napoleon,—impelled by want of cash, or perhaps by sheer pique at his good-natured brother, whose favourite walk they shaded,—ordered them to be cut down and sold. The walk still remains in the ruinous state in which the cruel imperial mandate left it; great holes and great roots every where appearing. So firmly and deeply had some of these trees been rooted, in the course of two centuries, that, in their fall, they tore up masses of the ponderous stone and brick wall. Below, or on the outside of the rampart, are many small gardens, belonging to the inhabitants: these are, in general, neatly kept. We ascended a building on the ramparts, called the Observatory, and enjoyed a fine evening prospect from the summit; but we saw no astronomical instruments, nor any observer but an obliging garrulous old Dutchwoman.

The neighbourhood of Utrecht, we may remark, is celebrated for the culture of such forest-trees as are best adapted for forming avenues and groves. Limes are reared in great numbers, and the true Dutch elm is here to be found in perfection. This elm is the *Ulmus major* of Sir James Smith's "English Botany," described under the name of *U. Hollandica* in Miller's "Gardener's Dictionary." As this tree is, in our Scottish nurseries, frequently confounded with *U. montana*, we think it right to give, in the Appendix, No. V., the characters of both, as well as of the other species commonly cultivated in Britain.

From Utrecht to Breda.

Sept. 5.—Betimes this morning we set off, by the diligence, for Breda. Few and slight are the observations which travellers can make in passing through a country in this hurried way. During the first part of the day's journey, the prospect was rich and varied. Several country houses appeared, with gardens partaking of the usual stiff Dutch style. We crossed the river Leek, as a branch of the Old Rhine is now called, and immediately entered the village of *Vianen*. Here are to be seen the remains, now very slight, of a garden which had once been richly ornamented with temples, statues, and mounts or artificial hills: it belongs to the seat of the Counts of Brederode, a family distinguished in the history of Protestantism, as among the earliest and warmest promoters of the reformed religion in the Netherlands. Not far from Vianen, we noticed, on a lawn fronting a neat house, some lime-trees, with their stems painted with alternate bands of black and white, by way of ornament!—the only instance we have met with of this absurdly bad taste, which, however, we believe, is common in North Holland. Some rows of medlars (*Mespilus Germanica*), trained as dwarfish standard fruit-trees, appeared in a neighbouring orchard; and these formed the first collection of medlar-trees we had seen on our route.

In the little village of Leckerfeldt we remarked a spruce-fir*, placed in the middle of the main street, and surrounded with a rail. This was not a revolutionary tree of liberty, but evidently one lately planted in honour of the

* *Pinus Abies*, Common Spruce, or Prussian Fir; in Scotland, usually called Norway Spruce.

restoration of the Orange Family. Unluckily it is very sickly, and it will probably soon die. Indeed, if there be no particular reason for preferring the spruce-fir, the inhabitants could not have selected a tree less likely to flourish in their towns, or worse adapted to the soil of Holland. An oak would have grown much better. But we afterwards passed through two other villages, Leckmont and Meerkis, in each of which a spruce-fir was, in like manner, planted at the market-place, and railed in. This kind of tree, therefore, seems to be here appropriated to the purpose. Inscriptions, in the Dutch language, were painted on boards beside the trees. We had not time to try our skill in decyphering these; but we recollect to have noticed *Oranje boven* figuring in conspicuous characters. At a *bierkroegje* or change-house in the last of these villages, our drivers regaled themselves with some simple fare and a pipe; and the horses meanwhile got a feed of brown bread, for slicing down which there was fixed, upon a bench near the door, a knife moving upon a hinge.

Having crossed the Meruwe or Zwaan ferry, a branch of the Maese,—with diligence, horses, drivers, passengers and all, crammed into the same bac,—we left Gorchum on one side of the river and Worchum on the other, at a very short distance on our right. We soon after entered on a stretch of poor country, wheremoorand marsh prevailed much more than corn-land or even pasture. Grebes and water-hens* became common in the extensive swampy pools which now presented themselves. We noticed many oval pieces of basket-work, like large nests, suspended by sticks over

* We could distinguish both the red-headed or crested grebe (*Colymbus cristatus*), and the black-headed or eared (*C. auritus*); the common water-hen (*Fulica chloropus*), and the coot (*F. atra*), seemed equally plentiful.

the pools : these, we understood, were traps for taking wild ducks and different kinds of water-fowl. A single stork appeared on the road before us ; and it was so indifferent to our approach, that the postilion drove it off with his whip. The water-hemlock and water-soldier plants were extremely abundant in the ditches and pools, the latter covering some hundreds of acres. *Oenanthe fistulosa* and *Selinum carvifolium* were likewise plentiful. In a few places *Butomus umbellatus*, or the flowering-rush, appeared : it was of more vigorous growth than in Scotland, and its leaves are here worked into mats. Where the ground was somewhat dry, and cultivation was practicable, barley, oats, and buckwheat, were presently to be seen. Flax was not uncommon, and we perceived that it is the practice to dry it on the field before being steeped. Hemp, too, seemed to be a favourite crop : the male or fimble hemp, appeared to have been lately pulled up, and laid aside in bundles. We passed several extensive osier-holts, and saw much more waste surface which might be occupied in that way. The willows cultivated are chiefly the coarse, strong growing kinds, better adapted for making barrel-hoops and large crets, than for basket-work. In passing a hamlet, indeed, we noticed many rods prepared for these purposes, and also some hoops ready split. The principal kind of wood on this road is pollard willow : but we remarked likewise some pollard ash, and a very little oak.

The house and the barn of the boor in this part of the country are commonly joined together, or under one great roof. Over the door of the house the thatched roof is curved upwards like an arch ; and when the thatch is overgrown with mosses (*Dicranums*, *Tortulas*, &c.) the effect is rather pleasing. A small kitchen-garden immediately adjoins ; and this is generally inclosed with a fence of

hornbeam, elder, or willow, frequently trained to a coarse trellis. In some instances the situation of these farm-steadings was so low, that only a few feet of soil appeared on the exterior of either house or barn : the rest was, at this rainy season, a dreary expanse of water ; but the water was shallow, and the bottom firm ; for we sometimes saw cows grazing, while they were wading up to the knees. These animals were large, and always either of a black, or black and white colour. The boors are provided with flat-bottomed boats, for passing to and from their homes on such emergencies.

For a great way, the massy dike along which we passed supports, on the east side, next to the higher land, a body of water like a narrow lake, which had now risen to a considerable height against its side. On this account the westward slope of the dike, next to the lower country, presents a much larger dry surface than the other ; and of this circumstance the industrious Dutch have availed themselves. They have carefully planted fruit-trees, especially apples and pears, on the west slope. These have become exuberant and fruitful trees, affording, at this time, both the most abundant crops and the largest fruit which we have seen in Holland. We easily recognised the Red Bellefleur, Dutch Paradise, Red Calville, and Courpendu, as among the varieties most commonly here cultivated. But there were several others, the appearance of which was not familiar to us : of these we could only pick up the names of the Hinneber-appel, the Tarv, the Westland Bellefleur, and the Zwiebel ; the last bearing a considerable resemblance to the Stoup-Leadington of Clydesdale, or the Cat's-head of England. The trees we agreed in pronouncing to be the largest and finest of the kind we had yet seen in our journey ; their horizontal branches extend-

ing widely both up and down the declivity. It was impossible for us not to recall to mind the observations of the late Dr WALKER, Professor of Natural History at Edinburgh, on the advantages of planting fruit-trees on sloping banks, when we had thus under our eye so striking an illustration of their truth*.

In the course of the afternoon, we again crossed the Maes or Holland's Diep; and for the last twenty miles the country appeared comparatively barren. Although the day was bright, and the prospects occasionally assumed to us a new character, the slowness and clumsiness of the post-wegen tried our patience. We had left Utrecht at six in the morning, and it was past seven in the evening before we reached Breda, although the distance is not much greater than between Edinburgh and Glasgow.

Being about to leave Holland, we amused ourselves, in the evening, in collecting the general impressions left on our minds by what we had seen of the country. That part which we have visited was long ago well characterised by Sir William Temple, when he said, "It is like the sea in a calm, and looks as if, after a long contention between land and water, which it should belong to, it had at length been divided between them." By much the greater part is in meadow; and the natural grasses are excellent, *Poa trivialis* and *pratensis*, *Holcus lanatus*, and *Dactylis glomerata*, being abundant. Large crops of wheat had in some places been produced, the stems taller but not thicker or stronger than in Scotland. But the soil, upon the whole,

* These observations are to be found in the Appendix to Vol. II. of Lord Woodhouselee's Life of Lord Kames. As they are equally short as judicious, and are not generally known, we have given them a place in the Appendix, No. VI.

does not appear to be rich. In some places it is little better than sand, tinged with alluvion-earth. In other situations, muddy or sludgy deposits have accumulated over the sand, so as to form a layer of loamy or clayey soil, but not of a very kindly character.—To a stranger the dikes, the drains, and the water-mills, form very striking features of the country. Metelercamp remarks, that Holland was defended with dikes some ages too soon; which is, in other words, to say, that in the progress of time the tendency to *atterissement* or *silting-up* (so well illustrated by Mr STEVENSON, civil engineer, in the 2d volume of the Wernerian Memoirs) has here, as elsewhere, operated invariably. In former ages, the Rhine, at its embouchure, spread over a great surface of country, and the clay suspended in the waters was slowly and equally deposited over the whole. At the present day, this deposit must take place chiefly in the flat part of the alveus of the river itself, and in the bottom of the lakes and canals in which it is lost. The progress of this silting up is universally acknowledged in Holland: in some places, the *bottom* of the river or of the canal is ascertained to be already considerably higher than the meadows or corn-fields on each side. This unnatural condition cannot well endure for another age. The principal Dutch engineers, we understand, have projected a general reform in the *waterstadt*, on liberal and enlightened principles. Instead of allowing, as at present, rich individuals and monied companies to heighten at pleasure the embankments for defence of their private properties, it has been proposed to open a free course to the ocean in the lowest parts of the country, by having regard only to the natural course of the outlets, by keeping down all private dikes there, and by raising very considerably the grand embankments. In the execution of this project, much temporary inconvenience

must doubtless result to individuals occupying the lowest districts; but in this way only can any prospect be indulged of the former state of things being restored. The soil or mud annually left by the overflowing of waters, would not only meliorate the lowest meadows and cornlands, but would gradually raise them; while the main dikes would afford far greater security to the inhabitants in general.

To revert to our proper department.—We have become somewhat reconciled to the Dutch style of gardening, as suited equally to their limited territory, and to their national character. The villa gardens, being necessarily of very circumscribed dimensions, often literally a “nook of earth,” formal trimness is all that can be looked for; and the garden harmonizes with the small painted dwelling-house, or “country-box,” as it would be termed by a London tradesman. Even the best of the larger gardens which we have seen, consist chiefly of a series of straight alleys and of green parapets, with sometimes a regular serpentine walk, and perhaps a formal berceau. The ideas and habits of the people are formed in crowded commercial towns: these they carry with them into their rural retreats, producing stiffness and trimness, but a supreme regard to comfort and utility. A tasteful pavilion and pier on the margin of the principal canal, facilitates communication with the treckschuyt; and a subordinate canal is generally carried up to the kitchen-door, for the more convenient supply of all heavy articles from the towns. Small bridges and boat-houses are frequently the chief ornamental structures of the pleasure-grounds. The garden-walks are both sheltered and shaded, and are smoothly laid with broken sea-shells of the purest white colour. We may here remark, that both in Amsterdam and Rotterdam we observed

depots of *shells* for sale. The whole shores of Holland abound in the littoral species which burrow in the sand. The prevailing shells are those of the common cockle (*Cardium edule*), fool's-cockle (*Macra solida*), and *M. subtruncata*; but fragments of other species may occasionally be observed. The collecting of these shells is a branch of the fisherman's business on the sea-coast; and it has been described to us by a gentleman who witnessed it at Catwyk. Whenever the sea breaks with a heavy surf, it throws up great quantities of dead shells. The fishermen then make use of a kind of *net-shovel*, in which they dexterously catch the shells while afloat on the surface of the breakers. They thus receive them clean and ready for use; pack them instantly into carts, and afterwards send them to the depots, from whence they are transported to all parts of Holland by means of the canals.

The orchards and the culinary gardens of Holland seem in general to be well managed. In producing vegetables, the Dutch may be regarded as excelling the Flemings; but they are inferior to the cultivators for the London market. If therefore Fowler, in his "Worthies," be correct in saying, that kitchen-gardening "crept from Holland into Kent," the English, it must be admitted, have greatly improved upon the lesson they thus received.

We would recommend to our Society, as soon as a Hall is prepared, and a Library formed, to procure from Mr Maaskamp of Amsterdam, or Mr Altheer of Utrecht, the principal Dutch publications on Horticulture; particularly Knoop's "Beschrijving en Afbeeldingen van Appelen, Peeren, en ondere Vrugt-blomen," published at Dordrecht in 1790; and Munting's "Beschrijving der Ardgewassen, als Boomen, Heesters, Kruiden en Bloemen," also with plates.

BRED A.

Sept. 6.—Very early in the morning we procured a guide, being anxious to view this ancient capital of Dutch Brabant, without delaying our journey.

We aroused the beadle from his slumbers, and got access to the *Church*,—a venerable structure, containing some very old monuments. Of these, the mausoleum of Count Engelbrecht of Nassau is the finest. The base and roof are of Lydian-stone; the figures in alabaster; and the chief of these are regarded as the work of Michael Angelo Buonarroti. The sculpture is beautiful, and strikingly faithful; but the Count on his deathbed, frightfully emaciated, is certainly not an agreeable subject. The pale hue of the alabaster, partly polished by the fingers of visitants, and partly covered with dust, imparts additional horror to the figure, and, at the early hour at which we viewed it, the yet uncertain light of the dawn aided the illusion. In a small chapel at one end of the church, the great brass font of former ages, about fourteen feet in height, is still preserved: so massy is it, that a sort of lever-crane appears to have been employed for raising the cover.

The *Castle*, built by King William, is a large square structure, surrounded by a branch of the river Merck. Here we were refused admittance by the sentinels, and we had not time to apply in regular form for an order. The Stadtholder's Palace is close by; and also the house in which Charles II. resided, during part of his exile, and at the moment when he was called to the throne. Although Breda is a regularly fortified town, and esteemed one of the strongest in the Low Countries, room has been found, near the Palace, for several fine serpentine walks, shaded by trees. These walks have of late years been thrown

open to the public. Large spruce-firs are here common ; the spruce seeming in this country to be considered and employed as an ornamental tree.

Kaperken's Nursery-Garden.

Having inquired for the best nursery-gardens of Breda, we were conducted to the premisses of Mr Antonius Kaperken. Here we had the satisfaction to see a considerable collection of healthy young fruit-trees, particularly Apricots and Mulberries. The *Breda Apricot* is well known and highly esteemed in Scotland, both on account of its large size and fine flavour. Mr Kaperken, however, knew of no particular apricot which deserved to bear that name ; and he told us, that no very old apricot-trees are to be found in the place. We believe that the Breda apricot no longer exists here ; the kind now cultivated being, almost exclusively, the *Abricot de Hollande*, a small round fruit. Young apricot-trees are here trained both for walls and as standards ; but more generally for the wall. The apricots had chiefly been budded ; the mulberries had been propagated by the method of inarching or approach-grafting. The more healthy trees of both kinds had this season made shoots three or four feet long.

The *Yut-pear* tree we found in this garden of a large size ; and the fruit was now in perfection. We were invited to taste the fruit : it appeared to us, when thus taken directly from the tree, to be quite fit for the dessert, and superior to any other pear similarly treated. Notwithstanding this quality, we were led to understand that it keeps longer than the *epergne* or our *jargonelle* ; and to the good qualities of that pear, juiciness and sweetness, it adds a rich perfumed flavour. Mr Kaperken has also very healthy young trees of the *Yut-pear* ; and we would suggest to the

Society, that, as soon as the Experimental Garden is established, some of these should be procured from Breda, with the view of making sure of possessing the genuine variety.—The apples in this garden were chiefly Calvilles; the red autumn and red winter, and also the white winter.

In the borders were some rows of celeriac or knoll-celery, now in seed. When intended for yielding seed, the plant is raised in the spring, as in this case; when meant for kitchen use, it is not sown till July, is planted out in August or September, and allowed to swell in the ground till towards the end of November, when it may be taken up and stored. The purple turnip-cabbage, or kohl-rübé*, here formed a garden crop; and we do not recollect to have met with it before, in the course of our trip.

In returning to our inn, we walked along the ramparts; and having ascended a wind-mill, erected on a projecting bastion, enjoyed a pretty good view of the works of this strong place, so celebrated in the annals of warfare. The ramparts were formerly adorned with trees; but many of these have been felled during the late troubles, only a few large elms now remaining.

From Breda to Antwerp.

Having last night left notice with the postmaster to furnish us with a private carriage and pair for Antwerp, we

* This also is considered as a variety of the Proteus-like species *Brassica oleracea*, which has been already mentioned as growing in its native state at the chalk-cliffs of Dover Castle; and as having given origin to the different kinds of white and red cabbages and savoys, which form the leaves into a head; the various sorts of borecoles, coleworts, and kale, which grow with their leaves loose; and cauliflower and broccoli, which form their stalks and flower-buds into a head.

set off in the forenoon. We got on very slowly; but, on our expressing some impatience, our postilion soon cured us, by letting us know that the same horses were to go all the way, about forty miles. The road was heavy and unmettled; and we would have gladly exchanged it for the noisy pavé near Ghent. In general, the country was rather poor and moorish. In the moist grounds, sweet Gale (*Myrica Gale*)*, was not uncommon; and on the sandy moors in one place we descried a few plants of German Tamarisk (*Tamarix Germanica*), which would scarcely survive on an exposed Scottish heath. Where cultivation was practicable, husbandry was not neglected. The corn was in stooks on the field; and we now observed for the first time a wand stuck into every tenth stook, denoting that it had been claimed or set apart as tithe,—a sure indication that we were leaving the presbyterian territory. The crops of spurrey after rye and wheat, already clothed the fields with a dense green herbage, nearly concealing the stubble. This cultivated spurrey is decidedly a more desirable fodder-plant than the common native *yar* (*Spergula arvensis*) of our Scottish fields; and it deserves the attention of our agriculturists. It seems to be the *Spergula pentandra* of botanists, improved in size and succulence by cultivation. The great additional quantity of green food for cows acquired by means of this after-crop of spurrey, must prove highly useful to the farmer.

For several hours, the road preserved a uniform straight line, as far as the eye could reach. Through a dreary sandy moor, of some miles in extent, it was lined with recently planted beech-trees, generally about twenty feet

* In our own country, this shrub is often called *Scots Myrtle*; here its popular name is *Myrtle of Brabant*.

high, and which had been trained in the nurseries to that form. Many hundreds of these had fairly died; indeed, not more than one in a dozen presented a terminating tuft of green leaves, just sufficient to intimate that life was not extinct. Yet no little pains had been taken in planting these tall spiry trees: the soil was generally heaped immediately around the base of the stem, in order to preserve some degree of moisture about it, and at the same time a hollow or small pit was formed on the outside of the heap, with the view of detaining rain-water, and making it sink down to the roots. Such trees are not likely either to afford shade from the sun or shelter from the storm, nor to prove anywise ornamental; but they may probably be very useful during winter, in serving as direction-posts to point out the track of the road, when the cultivated fields and dangerous quagmires are equally buried in snow, or covered with water.

As we approached Antwerp, the country improved, becoming clothed with large trees, and with oak coppices. It was between seven and eight at night before we arrived at the town, our journey having occupied almost nine hours. Instead of ordering our postilion to drive to the Hotel St Antoine, where we were known, and where we had, on our former visit to this city, been comfortably lodged, we allowed him to take us to the inn to which he himself gave the preference; but we suffered for our thoughtlessness, the accommodations proving very inferior.

From Antwerp to Brussels.

Sept. 7.—Finding ourselves very uncomfortable in our lodgings, we determined to proceed as fast as possible to Brussels, about seven-and-twenty miles distant. By six in the morning we had finished breakfast, having by expe-

rience learned, that, in "diligence" travelling, it is quite proper to make that preliminary preparation, and we exchanged with satisfaction our musty-scented and dirty apartments for a stage-coach, crowded with young Antwerpians leaving town in their holiday-apparel. The morning was bright and serene, and displayed in all its beauty a rich and well wooded district, which acquired additional charms from being contrasted with the prevailing dreary scene of yesterday.

We changed horses at *Conti*, a pretty village, surrounded with gardens, orchards, and rich fields of clover. *Lycium barbarum* appeared in the hedges, and at this time had the fruit formed upon it. We could distinguish the large leaves of Catalpa-trees in the gardens; and the elegant foliage of the acacia (*Robinia pseud-acacia*) often presented itself. Mr Hay here took notice of a curious and very neat beech-hedge, about five feet in height. The plants were placed in a straight line, at equal distances, but had been planted in a slanting direction, and were made to pass each other obliquely in the manner of a St Andrew's cross: they had at first been retained in that posture by tying, but this seemed no longer necessary, the branches having united by natural inarching.

The next stage was *Malines* or Mechlin. This is a large city, the metropolitan see of Austrian Flanders, and the birth-place of old Dodonæus. The coach stopped in the Grande Place, not far from the great church. This church appeared to be a noble structure, and Mr Macdonald, who made a hasty visit to it, reported that the interior was richly decorated. Doubtless the gardens and nurseries in the neighbourhood of such a city, would have afforded us a pleasing and perhaps profitable treat. The garden of Mr Wiegiers had been recommended to our at-

tion by our friends at Ghent; and Malines has long been distinguished for florists who excel in pinks and roses. It was with regret, therefore, that we found ourselves obliged to set forward.

Some of the common crops in this neighbourhood are little known in North Britain; particularly madder and coriander.

After passing the river Dyle, the country became diversified with gentle swellings; and as we approached Brussels, more considerable heights came in view. The prison-house at Vilvorde attracted our notice, and one of our fellow-travellers highly extolled the arrangements and discipline of this penitentiary. The entrance to Brussels on this side is beautiful. On the right we had the Palace of Lacken, finely situate on an eminence, from which a lawn, ornamented with clumps of shrubs and scattered trees, slopes gradually down to a piece of water on a level with the high road. On the left we had the small river Senne, or rather the Mechlin canal, which, by means of successive levels and locks, communicates with the sea at Antwerp; and beyond it, some handsome seats of the nobility and richer merchants. After having spent a month in a flat alluvial country, where scarce a stone was to be seen, and where there was no trace of any rock *in situ*, we were glad to perceive symptoms of our having entered a district of quarries, from which we might learn the nature of the mineral strata; for now the houses and inclosure walls were all built of sandstone and trap-rock.

BRUSSELS.

We put up at the hotel called *Couronne d'Espagne*, kept by Gregoire de Silly, in the Old Corn-market. Af-

ter dining at the table d'hôte, where we met with an Irish hero of Waterloo, we walked towards the Court end of the town; and, on our way, ascending a magnificent flight of steps, entered an ancient church, which we soon ascertained to be the celebrated one of St Gudula. Service was now performing with great pomp; but we had witnessed a still more splendid ceremony of the kind at Ghent. We ventured sufficiently near the pulpit, at this time unoccupied, to have a complete view of it. It is composed of oak, most richly carved; the whole history of the expulsion of our First Parents from the Garden of Eden by an angel with a flaming sword, being represented in bass-relief.

Leaving St Gudule's, we proceeded into The Park. Much as we had heard this great square praised, it certainly surpassed in beauty and grandeur any idea we had formed. The grandeur consists very much in the spaciousness of the central area, and in the number and size of the limes, elms, and walnuts, that shade the broad gravel-walks by which it is intersected. These walks are appropriated to pedestrians; and at this time we felt them refreshingly cool, our pocket-thermometer indicating 74° in the shade, and 86° in the sun. The statues seemed to be well executed, and judiciously disposed: the *Termini*, considered as ornaments in a public promenade, were new to us. The fountain in which Peter, the young Czar of all the Russias, accidentally soused himself, is mentioned by every tourist. In the Parc is situate the *Hôtel de Bellevue*, much frequented by the fashionable English, who, to suit their London habits, had here got the time for public dining retarded by about three hours. In the fine walks which we were now leisurely perambulating, were our military countrymen assembled and marshalled on the portentous night between the 15th and 16th June 1815, when the inconcei-

vable rapidity of Buonaparte's movements enabled him almost to surprise the Duke of Wellington.

We afterwards pursued a charming walk along the ramparts, commanding a rich and extensive view, of which the Forest of Soigné formed a prominent and interesting feature. At our feet grew the annual species of thyme (*Acy-nos vulgaris*), a rare plant in Scotland.

Having learned that l'Eglise des Augustins had been opened by a respectable English clergyman, for the accommodation of the many British subjects now resident in Brussels, we attended the evening service. The congregation was far from being numerous, and appeared to be composed chiefly of domestics; but we understand that the morning service is much better attended. As we walked homewards, we perceived that the theatre was open; and, notwithstanding the oppressive heat of the weather, we were told that it overflowed with company. This, we believe, was chiefly to be ascribed to the circumstance of the King being present; for although his Majesty, soon after assuming the sovereignty, issued a proclamation enjoining the strict observance of the Sabbath in his new dominions, such amusements, it appears, are deemed not incompatible, provided the usual canonical hours be respected.—At 10 P. M. the thermometer still indicated 71°.

Vegetable and Fruit Market.

Sept. 8.—In the morning we visited the green-market. The supply was good, but not extensive; this not being a regular market-day. Cauliflower and cabbages, both red and white, were predominant articles. Celery was strong, but quite green, being evidently intended only for soups. Even at this early season, Brussels sprouts were excellent: only very small compact crowns are brought to market, and they

are all picked from the stems, and set out in baskets like button-mushrooms. Both the peas and broad beans were old, and came to market ready shelled. The potatoes were chiefly of the red sort, some round, and some of the long kidney shape; at the table d'hôte, we found the kidney-shaped to be the best. Kohlrübe was plentiful on the stalls; it therefore appears that it is pretty commonly cultivated in Brabant.

In the fruit-market there was a considerable show of articles, consisting of apples, pears, peaches, and grapes. The apples were not yet ripe, and they did not promise any thing remarkable. The pears consisted chiefly of bergamots of very ordinary appearance, and of small rousselets deserving the same character. At the best stalls, however, two or three other kinds appeared. Among these were still some specimens of the *Beau present*, the season of this fruit, however, being nearly past. If this beau present be really distinct from the epergne or our jargonelle, it is certainly well worthy of the attention of the Society. The Caillot-rosat was of large size, but not very good to eat, perhaps owing to the unfavourable summer. The Fondante de Brest was the only other pear worth noticing; and in this we recognised the Cheneau of the old monastic garden at Bruges, p. 31. The peaches were few, and of very indifferent quality. The grapes, also, were but inferior,—certainly not such as would be presented at any gentleman's table in Scotland, if he possessed a vinery of his own; yet here they were greedily bought up by our emigrant nobility and gentry! Green or fresh cob-nuts were common; and also new filberts. A long and narrow plum, of a reddish purple colour and of good flavour, was very abundant. It resembles the Hungarian or blue egg-plum, and is nearly allied to the Wentworth: it was here

called the *Altesse*. The *Reine Claude*, or our green-gage, was common, and of excellent quality. Gurkins or small cucumbers were plentiful. The quantities of *roasted* apples and pears exposed for sale in the market, or hawked through the streets, at first surprised us; but we learned that the common people use them very much as an article of diet.

Frog-Market.

In a lane hard by the green and fruit stalls, we fell in with the frog-market, which was a novelty to us. The animals are brought alive in pails and cans, and are sold by tale. The frog-women are arranged on forms like the oyster-wives in the Edinburgh fish-market; and, like them, they prepare the article for the purchaser on the spot: as the oyster-woman dexterously opens the shells with her *gully*, the frog-woman shews no less adroitness, though more barbarity, in the exercise of her scissors: with these she clips off the hind limbs (being the only parts used), flaying them at the same time with great rapidity, and sticking them on wooden skewers. Many hundreds of the bodies of the frogs, thus cruelly mangled, were crawling in the kennel, or lying in heaps, till they should be carried off in the dust-carts.

We may mention, that the species thus used as food (*Rana esculenta*) has never been observed by us as a native of Scotland, though it is marked, in natural history works, as a British species. It is generally larger, and more arched on the back, than our common frog (*R. temporaria*); and the colour is rather green, while ours is nearly yellow. We noticed, however, many specimens, perhaps males, marked longitudinally over the back with three faint yellow lines.

Botanic Garden.

The spot now occupied by the botanic garden had formerly been a flower-parterre and shrubbery, belonging to the palace of the Arch-Duchess Marie-Christina, and was appropriated to its present purpose at the time of the general establishment of central schools, when the principal part of the palace itself was converted into a gallery for paintings. The garden is of small extent: it contains an arrangement of plants used in medicine, but little else, excepting a noble collection of orange-trees. Of these there are no fewer than 170, large and small. Several of the larger are really admirable plants, about eighteen feet high, including the box or tub in which they are planted, with stems two feet in circumference, and not less than 150 years old; some of them indeed have seen more than two centuries. These fine plants had, in former times, belonged to the various Arch Dukes and Duchesses of Austria, who held their court at Brussels; and, to the credit of all parties, they have remained uninjured during the revolutionary period. Sheep-droppings had been thickly strewed over the surface of the soil in the boxes, to strengthen the plants, as the gardener said, and promote their flowering. Besides the orange-trees properly so called, there are a good many citrons (*Citrus medica*); and of these, some are *sawage* or ungrafted, the twigs being armed with slight spines; others are *bigarades*, which are frequently allowed to produce their fruit. The fruit is distinguished by having a very thick rind, at once bitter and acid, and which is here in high repute as a seasoning in cookery.

The repository in which this ample collection is kept in the winter season, is necessarily very large: by pacing,

Mr Macdonald ascertained it to be about 140 feet long, by 50 in breadth. This house is lighted entirely by side-windows to the north and south, and it is pretty evident that it had not been originally destined to the purpose which it now serves. On inquiry, our conductor told us, that it was once a menage or riding-school,—afterwards a theatre,—and, on its third transformation, had become an orangery and lecture-room; for during the summer season botanical lectures are here delivered. Such an account could not fail to call to mind our Equestrian Circus at Edinburgh, which, in a tranquil city, visited by no kind of revolutions, has experienced an equally chequered fate, having become a church, a playhouse, and a concert-hall in succession.

The garden displayed to us unequivocal symptoms of the superiority of the climate of Brussels above that of Edinburgh. Many plants of *Althæa frutex* (*Hibiscus syriacus*), with flowers, both single and double, of various hues, purple, white and striped, were blooming freely in the open border. Some of them were ten feet high, and quite covered with blossoms. The oleander (*Nerium Oleander*) also appeared *en pleine terre*; but not in so vigorous a state as the *Hibiscus*. The mandrake (*Mandragora officinalis*) seems here to be a common border plant; and Marvel of Peru (*Mirabilis Jalapa*) is one of the principal ornaments of the showy parterres. The capsicum pepper (*Capsicum annum*) is planted out in the borders; and Love-apple (*Solanum Lycopersicum*) trained to the walls, is now covered with fruit.

Palace of Lacken.

In the afternoon we made an excursion to the Chateau de Schoemberg, near Lacken, built for the Arch-duchess, Princess of Saxe-Teschen, the sister of the unfortunate

Marie-Antoinette, and now appropriated as the rural palace of the King of the Netherlands, during the period of the Court being held at Brussels. We were very frankly admitted at the outer gate, the porter, on recognizing our country, politely intimating, that “des Anglais peuvent aller partout.” As we were passing the guard-house in advancing towards the palace, a *Qui vive?* announced the arrival of the King; the guard turned out; and presently a very plain coach and four drove up, wholly unattended. His Majesty was accompanied merely by a military officer, who sat on his left hand. We of course lifted our hats, and our salute was graciously returned. Having procured one of the attendants in royal livery to accompany us, we walked down the beautiful sloping lawn formerly mentioned, towards the lake. Here formal clumps of trees and shrubs had been planted; but these having been neglected, are beginning to assume a natural character. The addition of some scattered evergreens and weeping birches would greatly improve the scenery. Still these grounds are certainly very fine, even in their present state, when nature evidently does much more for them than art. The soil is a rich yellow loam, very different in quality from any which we had hitherto seen on the Continent. On this strong and rich soil many kinds of trees grow most luxuriantly. The walks are laid with a kind of rotten rock, apparently amygdaloidal trap-tuff much weathered, which makes a tolerably good substitute for gravel. The situation of the palace is exquisite; on an eminence, with gentle declivities around,—richly verdant lawns—groves—woods—water—cottages and a windmill, some way off,—and the turrets of Brussels in the distance. Our embroidered guide expressed regret that we could not see the Palace, on account of the King's return; and he tried to dissuade us from visiting the fruit and kitchen garden, declaring that it contained nothing worth

seeing; he even took his leave, after reiterating the same sentiment. In all this he acted like a judicious courtier; for, having by perseverance made good our entry into this garden, we found that sure enough it displayed only the marks of departed grandeur and of present poverty. But the magnificence of the gardening establishment of the founder of the chateau was here evinced; the remains of two large hot-houses, and of a vast greenhouse or orangery, testifying it most distinctly. The orangery had been about 200 feet in length, and 26 feet in breadth, measuring over the front wall. One of the hot-houses immediately adjoining, intended probably for ornamental plants of warm climates, had been nearly 80 feet long, by 23 broad. The other hot-house, with an aspect somewhat different, had been more than 130 feet in length, by about 20 in breadth: this had probably been used for the forcing of peaches, grapes, and other fruits. A small portion of this last house is still kept up; the others are so completely in ruins, that it was not easy for us, in some places, to trace the foundations. The fruit-walls remain nearly in a perfect state, and are admirably suited to their purpose, being both lofty and well built: The bricks have been laid in rows, alternately lengthwise and endwise, so as to produce, when seen from a little distance, the appearance of diamond arrangement. There has not yet been much time for improvement by the new sovereign; but had he possessed a taste for horticulture or gardening, some repairs might before this have been accomplished: after having been three years in possession, however, it is evident that his Majesty cannot command a dessert of fruit from his own garden. The ground is cropped with the usual culinary vegetables, cultivated in very ordinary style. We left this garden, with a conviction, that, considering the richness of the soil,

—the genial nature of the climate,—the facilities afforded by its being ready furnished with the most desirable walls, for peaches, nectarines, plums, pears, and grapes,—it might, in the hands of a person versed in practical horticulture, become, in a very few years, one of the most delightful, as well as most productive spots in the north of Europe.

So great was the afternoon's heat, that we were glad to retreat for a time into the rustic bowers of a kind of public garden, in the village of Lacken; and afterwards to linger at a popinjay pole, where a number of young men, with their upper garments doffed, were keenly engaged in the exercise of archery, "shooting the eagle" as it is commonly styled. We walked home, in the cool of the evening, by a long avenue called *Allée verte*, planted chiefly with limes and elms, and leading into the Rivage or lower part of Brussels.

Visit to Waterloo.

Sept. 9.—Although horticulture was our main object, we felt a strong desire to view the field of battle, in the neighbourhood of which we now found ourselves; and this being the anniversary of the institution of the Horticultural Society, we at once adopted the suggestion of Mr Hay, to suspend our usual pursuits, and to celebrate the day by a visit to the renowned scene. It was now the great fair of Louvain, and all sorts of vehicles were in requisition for that destination: after some delay, however, we procured a voiture, and set off.

We soon entered on the principal *garden-grounds* which supply Brussels with vegetables. They are very extensive on both sides of the road; and being nearly uninclosed, cauliflower, Brussels sprouts, savoys, and red cab-

bage, appeared as if cultivated in large fields. The red cabbage, though comparatively coarse, is the prevailing kind here; the sweet early cabbages seeming to be much neglected. The quarters occupied with asparagus and with red-beet were extensive, being scarcely inferior in size to those to be seen near Deptford. After passing the little village of Fleugat, grain-crops succeeded to those of kitchen greens. Harvest was here finished; or at least, only some patches of oats remained to be cut down. The second crops of the year were far advanced; turnips now almost covering the ground, and spurrey concealing the wheat and rye stubble. The soil is a rich free loam, of a light colour.

Forest of Soigné.

The road from Brussels to Waterloo, as is well known, passes for a great way through the Forest of Soigné. On entering the forest, our observations were necessarily confined to remarking the species and quality of the trees, and the kinds of native plants which grew near the roadside. The tree which chiefly prevails in the forest, is the common beech; but elm, oak, and abele, are not unfrequent, and they seemed to abound according to the order of priority in which they are here mentioned. Some ash-trees also appeared, but they were all small or young. The light-coloured foliage of tall willows was here and there distinguishable. A few small hornbeam-trees also occasionally presented themselves; and, in the moist parts, alder was extremely abundant as underwood. In many places, along the sides of the road, were piles of billets, prepared for being sent to Brussels as fire-wood. Each billet is about three feet long, and perhaps a foot in circumference. We could not help feeling some regret to see the fine and clean stems of hundreds of large beeches thus

cut to pieces, for such a purpose,—a feeling which may be pardoned in Scottish horticulturists. The woodmen live in small scattered cottages, sometimes having mud-walls, and deserving only the name of huts. The forest is traversed by narrow hunting roads; and, from the peep into the interior occasionally afforded by these, we could perceive that the surface is very unequal, sometimes rising into hillocks, and sometimes sinking into deep glens. Where the wood has recently been cut down, we remarked that a certain proportion of oak and beech standards had been left, to become large timber. Many of these reserved trees are tall: but, being at first naturally *drawn up*, by the closeness of the surrounding plants, and afterwards *pruned up*, so as to induce them to throw out numerous branches, which, we understand, are regularly lopped for fagots; the trunks have not swelled in proportion to the height attained. In other parts of the forest, where the wood has not lately been felled, it is evident that the same plan of leaving a few standards had in former times been acted upon; for lofty trees, from 80 to 100 feet high, are now and then to be seen towering among those of more ordinary dimensions. These reserved trees of former days, however, owing to the circumstances already pointed out, are remarkable only for their height. Among the thousands of tall beeches, not one *patula fagus* is to be seen; and the largest Soigné oak conveys no idea of the grandeur of the specimens of that tree to be seen in many an English park. The sides of the road resembled those often met with in Scotland; being in many places covered with brambles, lady-ferns, and foxgloves or dead-mens-bells (*Digitalis purpurea*); and large water-worn boulder-stones appearing here and there in the clayey banks.—In one place, however, we noticed the leaves of spotted lungwort (*Pulmonaria maculata*): and elsewhere, in a glade of

the forest, those either of *Helleborus viridis* or *foetidus*. These plants are considered as British natives, but are not characteristic of a Scottish road.

On emerging from the forest, we were regaled with the sight of some neat sequestered cottages, with small gardens and hop-plantations. The hops were by much the best we had seen, either in Kent or on the Continent; the plants being tall, and now completely covered with bunches of flowers. We here encountered a long range of heavy waggons, of various forms and sizes, some with five horses, others with eight. The greater part were loaded with coals from Charleroi (this sort of fuel not being entirely wanting at Brussels, though wood is more common), and two or three with large blocks of stone. On clearing the waggons, we got sight of the Church of *Waterloo*, and soon after entered the village. Here we agreed for the attendance of a German soldier, Johann Witfisch, as our guide. He belonged to a Hanoverian corps, and was stationed at the farm-house of La Haye Sainte, from which (if we understood his narrative aright) he escaped wounded, at the moment of its being carried by the enemy.

We knew beforehand that the village of Waterloo was at some distance from the field of battle; but, till we made inquiry, we were not aware that it was still a mile and a half to Mount St. John. Having got our guide mounted on the carriage, we desired our postillion to drive on to that village. We were now full of expectation; and it seemed as if we had come within hearing of some remains of the desperate strife; for we advanced in silence, as if listening,—each observing with curious eye, every object that presented itself. Our reverie was interrupted only by our coach stopping at the point where the road to Nivelles intersects that leading to Charleroi. We now pursued the

latter road on foot, and soon reached the farm-steading of *Mont St Jean*, where the walls shewed abundant marks of having been struck by bullets.

Field of Battle.

Although we may add little or nothing to the descriptions which have already been published, few readers, we presume, will be disinclined to accompany us in our walk over the field; our expectation of that indulgence depending wholly on the great interest conferred on the scene by the soldiers who there signalised themselves.

The first remarkable object which attracted our attention, was *The Wellington-Tree*, situate close by the high-road to Charleroi. This memorable tree is a large old Dutch Elm. It had suffered severely from the shot; but the fame it has acquired, from marking the principal position of the Commander-in-Chief, has since proved much more disastrous to it than the cannon-balls. No sooner does an English party appear at Mount St John, than boys ascend the unfortunate tree, and break off, not only twigs, but whole branches, which they tease the visitors to buy as relics. We tried to discourage this work of destruction, by reprobating the forwardness of the boys, and refusing to purchase. But unless a high rail be placed around the base of the tree, and a board denounce in legible characters the vengeance of the magistrate against offenders, the tree must inevitably perish. If the Sovereign of the Netherlands have not zeal enough to preserve this memorial of the station of the Prince of Waterloo, surely the English at Brussels might feel sufficient interest in their admiration of the hero, and of the valour of his soldiers, to induce them to ask permission of the Government to inclose the tree, and thus enable it to recover its injuries

and mark the spot to generations unborn*. Unless some such expedient be resorted to, it will speedily share the fate of Wallace's Oak in the Tor Wood, and exist only in the shape of patriotic walking-sticks and snuff-boxes.

Close by, Sir Alexander Gordon fell; and a very neat monument, constructed of Tournay marble, has here been erected to his memory. Our guide mentioned to us, that the Duke remained at this spot during a great part of the day, constantly despatching aides-de-camp in different directions, and occasionally himself galloping towards different posts, when they were the objects of the enemy's attack, or seemed otherwise to require his presence. Our guide observed him, on two occasions, go as far to his right as a rising ground behind Chateau de Gomont.

In front of Wellington's position, and at no great distance from it, is the farm-house, barn, and remains of the small orchard of *La Haye Sainte*, where our conductor, according to his own account, was stationed as a sharp-shooter. The troops within formed numerous loop-holes in the walls, through which they *canarded* the enemy when they approached. Our guide mentioned, that during the early part of the engagement, he saw through the loop-holes bodies of the cuirassed cavalry pressing forward along the high-road, towards the Duke's station, in the most daring style. Both the loop-holes and the breaches occasioned by cannon-balls have been filled up; but the marks of mending are still very evident. Nearly opposite to this farm-house, on the other side of the high way, is a sort of hollow or old gravel-pit, into which, we were told, a re-

* Mr John Scott, in his "Paris revisited in 1815," has, we find, celebrated this tree in a strain of lofty eloquence to which we have no pretensions. He did not once anticipate the fate to which it now seems destined,

giment of cuirassiers was tumbled pell-mell by a charge of the Horse Guards.

We proceeded along the high-road to *La Belle Alliance*, a shabby and dirty cot-house, now dignified with the title of "Hotel." Many shots appear to have struck the walls. From a neighbouring cottage, now wholly in ruins, Buonaparte for some time surveyed the progress of the dreadful struggle. Here the cross-road by which the Prussians from St Lambert advanced, touches the high-road to Charleroi; and this was the scene of the meeting of Blucher and Wellington, about eight in the evening, when the French had given way and were flying! What must have been the sensations of our great Commander at such a moment, when intense anxiety was giving place to honourable exultation, and when this feeling had to struggle with irrepressible grief for the dismal carnage of the day! After mutual congratulations, the two generals entered the cottage, and some refreshments were procured for them. Like thousands of our countrymen, we wished to see the apartment thus incidentally raised to celebrity. We accordingly entered; wine was speedily produced, and we filled bumpers to the healths of the two heroes*: the memory of the Scots who fell at Waterloo was not forgotten; nor did we omit to pledge our brother-gardeners, probably then met at Oman's in Edinburgh, to celebrate the eighth anniversary of the Caledonian Horticultural Society.

From this point we passed over the fields towards *Hougomont*,—a new name which the Duke, by a slight mistake in his dispatches, bestowed on the *Château de Gomont*. The ploughmen were now peaceably at work: the scene

* General Blucher died two years after the date of our visit to Waterloo.

was deserted, except by straggling parties of curious visitors like ourselves; we relapsed into cultivators, and examined the form of the plough, and the quality of the land. The soil is a soft sandy loam, of a light colour like that near Brussels. A few water-worn stones are interspersed; we broke one of the largest, and it appeared to be siliceous limestone.—In approaching the ruins of the mansion, we passed through the remains of a grove of large forest-trees, with what had been an orchard on our right hand. The trees which had suffered most severely from the shot have lately been cut down. But many of those left are terribly shattered. The beeches seem to be recovering most slowly from the effects of the balls: some ash-trees and oaks have also been sorely wounded, but appear to sustain such injuries better. A large and aged chesnut-tree (*Castanea vulgaris*) has been literally *riddled* with grape and musket shot; yet it is recovering, and may witness the passing away of some succeeding generations. The trees in the grove and in the orchard of Hougomont, it may be remarked, did not merely suffer by being perforated by shot of all descriptions, poured in upon them, in opposite directions, from both armies; but, for months after the battle was over, they were subjected to injuries more extensive and severe, through the zeal of English visitors to possess some relic from a spot so distinguished. The peasantry soon learned the value of a ball scooped out from a tree in which it had been lodged; they were ready, with chisels and hammers, to perform the operation in the presence of the purchaser, and, in removing a musket-bullet, an opening was generally made that would admit a six-pounder.—As we were about to enter the outer-gate of the chateau, two or three little fellows, pointing to a circular heap of earth mixed with ashes, and resembling the remains of a great bonfire, called

to us, “Voyez, Messieurs les Anglais, là, six cents Français furent brulés tous ensemble.” Having thus secured our attention, they set to scraping most actively, like so many terriers, and soon dug up fragments of human ribs and skulls, which they presented, with eager expectant countenances, shewing that these were marketable commodities to some persons,—and lisping in broken English, “De French-mans bone.”—The chateau is now a scorched ruin. The adjoining domestic chapel still retains its roof, over which the cross appears aloft and uninjured. On one side of these buildings is a kind of farm-yard; on the other is a garden, inclosed on the south by a long brick-wall. The dwelling-house and offices were set on fire by the bombs; and while the flames were raging, the French fearlessly tried to enter the court-yard. At this period, between forty and fifty of the English Guards threw themselves into the chapel. The enemy even attempted to force this sanctuary, by burning the door; and they partly succeeded. Over the back of the door is a large wooden crucifix; and at the farther extremity of the chapel, next the altar, and inclosed in a glass-case, is a Mariola, decked in tawdry silks. Our soldiers naturally tried to extinguish the fire, and they had prevented it from extending far into the chapel. A middle-aged woman, who appeared to be the mother of the children above mentioned, now hastily joined us, and proceeded to give an exposition of a miracle. “Mais voici,” she began, with no little volubility and emphasis,—“Mais voici, Messieurs, un *vrai* miracle, et ce qui vient à l’appui de l’Ecriture sainte; le talon de notre Seigneur est froissé,—c’est à dire,—(la même chose),” with a nod, “brulé,—tandis que Notre Dame ici, la Mère de Dieu,” with a courtesy, “reste tout-à-fait saine et sauve.” We perceived by the glances of

our matronly expositor, that the drift of her interference was to enhance the gratuity about to be given to her youngsters; and having satisfied them, or tried to do so (for they were not more poor than importunate, and had evidently benefited by the lessons of our lavish countrymen), we made our way into the garden. Here the Coldstream Guards were posted, and maintained themselves throughout the bloody day. In the course of the night previous to the battle, two rows of loop-holes, were formed along the wall, and a sort of scaffold was erected for those who were to fire through the upper tier. To each loop-hole, six soldiers were assigned, three continually discharging their pieces, while other three were loading. By these means the Guards harassed the approaching enemy in the most galling manner. The French, however, boldly forced their way through the grove and orchard already mentioned, till they came to the edge of a ditch on the outside of this fatal wall, where of course they fell in hundreds, or even thousands, till the ditch was literally filled. Such was the report of our guide; and we believe he was pretty correct.—The garden had been neatly laid out in the Flemish style, with clipped hedges, berceau walks, and fancy parterres; and some of the plants which still survive in the borders, afford evidence that a select collection of rarities had once existed here. We noticed a large tuft of the double purple Dame's-violet (*Hesperis matronalis*, var.), which is a rare garden-flower; and a well established stool of one of the less common species of Peony (perhaps *Pæonia hybrida* of Pallas), of which the leaves only presented themselves at this season of the year.

Leaving Hougomont, we returned towards Mount St John, by the right of the British position, and nearly in a line with the Nivelles road. Here a symptom of the slaughter, rather of a disgusting kind, presented itself,—a human

T

skull, still containing the brain, in a black and putrescent state. This remnant of humanity lay in the track of a farm-road, and had been left to be kicked about by the feet of the cart-horses; so indifferent had the common people become to such vestiges of the carnage. At no great distance from this spot, and just where the battle raged the hottest in the early part of the day, a solitary peasant, in his blue frock, was now mowing oats with the Hainault scythe. This Flemish instrument of reaping is furnished with three upright wooden forks, calculated to collect the stems of the grain as they are cut. By making the sweeps of one uniform length, the reaper lays what is cut, in very straight and regular parcels. Both Mr Hay and Mr Macdonald tried to use this implement, and were of opinion, that a little practice only would be required to render it easy, and that it might be advantageously employed on some of our Scottish farms, especially where *shearers* are not easily procured. At the end of the handle is a piece of squared wood, which is used for giving edge to the scythe.

Arriving again at the Wellington Tree, we now crossed towards the left of the British line, and walked along a by-road leading to the village of Ohain. By the side of this road is the hawthorn hedge, the literal *haye sainte*, behind which the Highland Regiments were posted on the day of trial, and through which they often burst to encounter and repel their daring antagonists, pursuing them across the rising ground, into hollows next to their own lines. The hedge and its low mud embankment are now completely in ruins; but when at their best, the protection afforded must have been very slender indeed. Several squadrons of British cavalry, including the Scots Greys, were stationed in hollow ground a short distance back from the hedge. In

this position they could not be seen by the advancing columns of the French ; and thousands of balls passed over their heads without doing injury. While waiting for orders to attack, they suffered only two casualties ; one common soldier had his head carried off, and a serjeant had his thigh fractured, by cannon-balls. At the proper moment, the cavalry advanced, passed between the Scots Regiments, leaped the hedge, or brushed through gaps, and fell on the astounded French. In this daring charge, they were at first commanded by Colonel Ponsonby, and, on his being mortally wounded, they were guided with no less skill and courage by Colonel Straton of the Enniskillen Dragoons.— Having proceeded in this direction till we approached the farm-houses of Papelotte and La Haye *, the extremity of the British left, we returned along the sloping ground in front of the hedge, where some of the deadliest conflicts took place, and where our countrymen, both cavalry and infantry, suffered the most. Here the Scots Greys captured a French eagle, and here the 42d and 92d regiments flanked the French infantry, when making one of their most formidable and daring charges.

On revisiting the barn and offices of the farm of Mount St John, we remarked (what had before escaped our notice, our eyes having then been eagerly turned towards the interesting prospect which was opening in front,) that the south sides of the walls of those offices were clothed with fruit-trees, chiefly pears ; and that these, having suffered little injury from the war which raged in their neighbourhood, were now loaded with fruit.

All the cabarets at Mount St John were this day full.

* In some accounts, the left extremity of the British army is described as resting on *Ter la Haye*. The farm of *Ter la Haye* is situate a mile to the rear, on the borders of the Forest of Soigné.

After having procured a room, and ordered our dinner, we were obliged to share both with an unprovided party from Scotland. There had been, we believe, five parties traversing the field, besides our own. Yet, such is the resort of visitants, chiefly English, that the villagers considered this as only a day of ordinary business.

On our way home we stopped for a short time at Waterloo, and entered the church. The walls of this small building are now covered with monumental tablets, sacred to the memory, not of Flemish churchmen or devotees, but of British soldiers. The liberality of sentiment displayed by the Roman Catholic clergy, in sanctioning these erections, is not undeserving of praise.—In a small garden behind a cottage in the village, we noticed a tombstone which had been lately erected: it covers the remains of Lieutenant-Colonel Stables, who “fell distinguished by his soldiers’ blessings, and his comrades’ tears.” We saw likewise the little garden in which the Marquis of Anglesea’s limb is buried: over the spot is planted a weeping willow, and a painted board explains in French the purport of this drooping emblem,—attractive conceits, which have doubtless proved very profitable to the domestics of the house: we were invited to enter and see the General’s boot, and a rush-bottomed chair, which was stained during the amputation.

Soon after sunset we regained the gates of Brussels, highly gratified with our day’s excursion. We had witnessed the arena on which the most momentous and decisive battle of modern times was decided, and on which, in the presence of brave friends and foes, the glory of Caledonia was nobly maintained by her sons; and we felt double satisfaction from being well assured, that our countrymen were here held in high estimation, not only for courage and

constancy in the field, but for general propriety of conduct when in quarters.

Sept. 10.—This being the market-day (Wednesday), Mr Macdonald went early in the morning to see the supply of culinary vegetables. He found it very copious. In the market-place and streets adjoining, there were nearly 200 carts or small waggons; and the vegetables were stowed, not only in the body of the cart, but in double rows of baskets or hampers, slung below. The bottoms of these baskets were not six inches clear of the ground,—a circumstance from which may be inferred the goodness and levelness of the roads around Brussels. The articles in general were of good quality; and Mr Macdonald brought home specimens of some of the best, that we might examine them more at leisure.

Brussels' Sprouts.

Being now on the spot where this culinary vegetable is considered to have originated,—where it has been cultivated and has remained genuine for more than four centuries,—and from which it takes its name; it may be expected that we should give such information as we could collect regarding it.

It is an accidental variety of the *Brassica oleracea*, distinguished by numerous small crowns, rosettes or sprouts, appearing in the axillæ of the principal stem-leaves, and soon causing these to drop off. The sprouts much resemble Savoy cabbages in miniature, and they are very tender and delicious when boiled. The mode of culture is nearly that applied to the cabbage-tribe in general.

In Britain, the seed is sown in April, the seedlings are transplanted in June; the plants are earthed up in Sep-

tember, and the crowns are ready for use in October and November. They continue good throughout the winter, unless the weather prove uncommonly boisterous and severe. Like German or curled greens, they are generally accounted more tender after having tasted the frost. Early in the spring, they are found very apt to run to flower.

Here at Brussels, the market is supplied with them during the greater part of the year. We were at first rather surprised to find them already on the stalls (8th September); but we now learn that they had even appeared so early as the beginning of last month, and are told that the supply will continue uninterrupted till the end of next April. This prolongation of the season of Brussels sprouts, is accomplished partly by successive sowings, and partly by the way in which the plants are treated. The first sowing is made early in spring, under glass; and other sowings follow at intervals of about three weeks, till near midsummer. The seedlings are planted out in rows, sometimes in large beds, and frequently between the lines of haricots, peas, or potatoes. It is a common practice to pinch off the tops of the plants a fortnight before the gathering of the rosettes is begun. This operation of pinching off the tops, we very commonly perform on garden-beans, in order to promote their fruitfulness; and with Brussels sprouts, it is done with the view of directing the energies of the plant to the production of lateral shoots. When the tops are left, they are used as greens in the early spring: they resemble turnip-leaves in taste, having a good deal of the peculiar flavour which distinguishes the Cruciferæ, while the sprouts are remarkably bland. Only a few crowns are taken from each plant at a gathering; the plant itself being thus left nearly uninjured. In this way it pushes out new rosettes in place of those removed. With us at home the plant is

generally drawn entire from the ground, and in that state sent to market,—a wasteful practice which cannot be too soon relinquished. The tendency to run to flower in the spring is restrained by lifting the plants, and laying them slantwise in the earth, in a north border or a shady place, as is often practised with cauliflower.

Brussels sprouts are now cultivated in all our first-rate private gardens in Scotland; but they are still little known in the Edinburgh green-market,—an omission which, we hope, will soon be supplied by our enterprising sale-gardeners. The Horticultural Society has for several years awarded premiums, in the month of December, for the best specimens then produced; and sprouts of excellent quality have sometimes been brought forward. We may remark, that very small and compact crowns are held in the highest esteem at Brussels; they are never more than an inch across, and frequently mere buttons; large crowns would be utterly rejected*.

Duc d'Areberg's Town-Garden.

Having been favoured with a letter of introduction through the attention of the Earl of Wemyss (then President of the Horticultural Society), we made a forenoon call at the residence of the Duc d'Areberg. Unluckily for us, the Duke was at this time gone to Louvain, near to which he has large estates, and which was now (as already noticed) the seat of a great fair. This interesting nobleman, it is

* A very compact and excellent sub-variety is cultivated by WALTER DICKSON, Esq. of Redbraes, near Edinburgh. By employing only the most genuine specimens for the production of seed, and by keeping these far apart from similar cruciform plants, the character has, for several years past, been preserved inviolate.

generally known, lost his sight while yet a young man, owing to the discharge of a fowling-piece from the hands of one of his intimate friends, while both were keenly engaged in hunting. This deplorable calamity, we understand, has been borne with heroic fortitude by the sufferer, who even found it necessary to offer consolation to the innocent author of the misfortune. In the madness of the revolutionary period, some of the Duke's estates were pillaged; but during the whole time he was personally respected, and allowed, not only to remain unmolested, but to retain considerable riches and influence. The ducal hotel at Brussels is one of the oldest and most splendid in the city, and is therefore commonly visited by strangers. After walking through it, we took this opportunity of viewing the garden, which is immediately at the back of the hotel. Owing to the declivity of the ground in this part of Brussels, a great portion of the garden is as high as the principal floor of the house. From the state apartments, one walks immediately out to a neat lawn on the same level. On this lawn grows a sumach-tree, of considerable age, and of great size, being near forty feet high, with a stem more than three feet and a half in circumference. The fine pictures in the Duke's possession have we believe, often been described, particularly a horse and his rider by Vandyke; but we do not recollect of its having been mentioned, that the collection of orange-trees, at this season arranged on the back lawn, is superb. An ungrafted tree formed the most handsome specimen of the orange-tribe we had yet seen, particularly in regard to the size and display of the head. The gardener mentioned, that it was nearly 400 years old, having, at that distance of time, been a present from an Infanta of Spain to an ancestor of the Duke.

A lime-tree of very venerable aspect bespeaks the antiquity of the place. The head of the tree is formed by three vast branches, all standing upright, and of course very close to each other. Each of these branches is about forty-five feet high, and as thick as the stem of an ordinary lime-tree. The whole height of the tree is somewhat more than seventy feet; and, four feet above the ground, the main trunk measures nine feet in circumference. Near the base are two protuberant rings of bark, from each of which numerous twigs or small branches have sprung; but a very large hole in this part of the trunk marks the progress of decay.

In the open border in the garden, we were agreeably surprised to find several plants of the Tree thorn-apple (*Datura arborea*), a native of Peru, and generally treated as a stove-plant in Britain. Two of these were at this time covered with their magnificently large and strongly odorous flowers. We measured several of the flowers, each of which was a foot in length. On inquiry, however, we learned, that these daturas are kept in the orangery during winter, and are planted out in the parterres at the approach of summer. A similar mode might, perhaps, be adopted in the southern and western counties of England.

We must not omit to take notice of a very large sort of hoe used for cleaning the gravel-walks in the Duke's garden. It is worked by two men, and is furnished with wheels, which greatly facilitate its movements: one man pulls forward, while the other regulates the hoe, according to the nature or abundance of the weeds to be extirpated. The despatch thus afforded is great; two men being able, effectually, and without interfering with the other garden operations, to do the work which formerly occupied six men, to the neglect of the ordinary business of the gar-

den for the time. It is best suited to the cleaning of light sandy walks, but a similar implement might in many places, where there are extensive gravel-walks, be advantageously employed with us.

In the afternoon we paid a visit to Mr GILLET, to whom we were recommended by Sir John Sinclair. He showed us his own little garden, which is a very nice spot, considering that it is almost in the midst of a great town; and he then conducted us to the garden of Mr Danoot, a distinguished banker, and a keen amateur gardener. On our way thither, we passed through several by-lanes, in which, at the door of every house, several females were seated on stools, busy at the knitting of lace, for which this city has long been celebrated. The rapidity of their manipulations excited our admiration.

M. Danoot's Garden

is elevated, and commands a view of a great part of Brussels, including the Church of St Gudule, and the tower of the Town-Hall, the two finest Gothic structures of the place. It is of small dimensions, but contains a great variety of fruit-trees and of ornamental plants; the former, indeed, are too much crowded together, as often happens in the gardens of amateurs. The west wall is only about ten feet high; yet fruit-trees, particularly pears and peaches, are planted at the distance of only five or six feet from each other; the peaches are trained to the wall in the fan mode, and the pears partly in that way, and partly in the horizontal style, but both much stinted for room: At the same time, the border in front of these is used as a nursery for dwarfing-stocks, than which scarce any crop could be more exhausting.

Having inquired of the gardener, which pears he considered the best in the garden, he, without hesitation, answered, "The St Germain, the Colmar, and the Grande Bretagne." The first two we knew well: the Grande Bretagne we desired to see, and soon recognised as our old acquaintance the Grey Achan, which was here honoured with a west wall, side by side with the Chaumontel, and in a garden where this last pear likewise appeared as a standard-tree. Let us beware, therefore, of undervaluing, in any case, the horticultural productions of our own country. While we avail ourselves of the Calbasse, the Yut, the Cheneau, or the Passe-Colmar, let us not forget the Muirfowl-egg, the Warden, the Ballencrief, the Pollockshaws, and others. One of the many advantages of our projected Horticultural Garden would be the forming a collection of the best Scottish pear-trees, and comparing their fruit with others; thus at once ascertaining their synonyms, and their relative value.

Mr Hay having remarked, that all the peach-trees were here small and young, and that we had not, since our arrival on the Continent, seen a single peach-tree of any considerable age, Mr Gillet mentioned, that at Brussels these trees seldom endure, in a bearing state, for more than seven or eight years. We had hitherto ascribed this early decay to the extreme lightness of the soil in the flat sandy provinces through which we had passed. But here the soil is different: and we suspect, that this rapid tendency to infertility must be owing, in no slight degree, to an incorrect mode of pruning being followed. It is only by the judicious exercise of the knife in the hands of a discriminating gardener, that a succession of bearing twigs can be elicited on the peach-tree, or on other trees that produce their fruit on the wood of the immediately preceding year.

Another wall was covered with vines, particularly the variety called Fontainebleau. The grapes were not yet ripe, but made such an approach to the state of maturity that there could be no doubt of their attaining it.

There is a glazed house for forcing grapes, and which contains various sorts of vines; but all the fruit was, of course, past. This vinery is between fifty and sixty feet long, and is heated by means both of an ordinary brick flue, and of earthen-ware pipes. The brick-flue passes along the front of the house, raised a little above the floor. The earthen-ware pipes are not conducted nearly on the same level, as is customary, but are led along a plank raised almost to the roof of the house, this kind of support having the preference, on account of its being a bad conductor of heat. The motive for the elevation of these pipes we could not discover; it being evident, that there is naturally a tendency in the heated air to ascend and to accumulate at the top of the house, without being led thither. The furnace is placed inside the house, and iron-pipes lead from it to those which are of earthen-ware. These earthen-ware pipes much resemble the *can-flues* described in the Memoirs of the Caledonian Horticultural Society, (vol. i. p. 65.), excepting that they are a good deal smaller in caliber. Tubes of dimensions so confined, indeed, could only be successfully employed where wood is the principal fuel; they would not answer well, where coal is much used, which yields a great quantity of soot. The vines are planted without, and are managed much in the same way as those described at Vroeylande (*suprà*, p. 62.) Sets of branches were now straggling on the ground in front of the house: these are to be forced next season; and those branches which have borne fruit this year, will then be excluded. The objections formerly stated, likewise occur here;—that there seems to be

a deficiency of good bearing wood, the shoots, even in this fine climate, requiring some degree of artificial shelter, especially to bring them to a state fit for being forced early in the following summer. Here, and in most of the grape-houses which we have seen, the vine-shoots are trained too close to the inside of the glass, so that the leaves are burnt and shrivelled. In this forcing-house, as is usual, the front of the roof extends over the sloping glass, till it reaches the perpendicular of the parapet. Mr Gillet had no doubt that the object of this sort of structure is to help to save the glass from the heavy falls of hail, which frequently accompany thunder-storms.

Just as he had made this observation, we perceived menacing thunder-clouds approaching: the gardener hastened to secure his glazed frames; Mr Gillet took his leave; and before we could get home, the whole horizon was overcast; lightning flashed incessantly; the streets seemed to have been suddenly swept of the inhabitants, the shop-doors were shut, and we could scarcely find a person of whom to inquire the way.—The day has been altogether sultry; and at 10 o'clock P. M. the mercury in the thermometer still remains at 72° Fahr.

Professor Van Mons.—New Pears.

Sept. 11.—M. VAN MONS is well known as a chemist, and he has likewise distinguished himself by his labours in horticulture, particularly in raising new varieties of fruits from the seed. Since the establishment of the present Government, he has been appointed to a professorship in the University of Louvain. At this time, however, he still had his principal residence at Brussels; and to-day when we called at his laboratory, we found him busied in some pharmaceutical operations. He received us very kindly;

passed a eulogium on Edinburgh as a seat of learning, and was particularly warm in the praises of Dr John Murray, both as an analyst and as an expounder of the theoretical doctrines of chemistry. He was much pleased, therefore, to find, that we were intimately acquainted with this distinguished chemist *, and that one of us had even been his schoolfellow.

He mentioned, that horticulture had been the favourite employment of his hours of relaxation for fourteen years past, and that he had, during that period, raised several hundreds of new pears, besides a good many apples, plums, cherries, and peaches,—all possessed of qualities so good or so promising, as to make it desirable to preserve the varieties. Of new seedling varieties of good pears, raised chiefly by himself and by M. DUQUESNE of Mons, he considers his present collection as extending to about 800! This number so greatly startled us, that at first we imagined he meant that he possessed 800 specimens, or young plants, of the new kinds deemed worthy of being propagated by grafting. These new kinds, we supposed, might perhaps amount to two or three dozen. But on putting the question distinctly, we found his meaning to be, that about 800 out of perhaps as many thousands of the new varieties raised by him and others from the seed, have proved worthy of preservation.

We had an opportunity of tasting the fruit of a few of these new pears; and, making allowance for their being late pears, and consequently not exactly in season, they seemed to us excellent, superior indeed to any we had seen on the Continent, scarcely excepting the Poire Madame and the Jut. The former of these, it may be noticed, is a summer

* Dr Murray has since died; in June 1820.

or early autumn pear, and the latter may be eaten directly from the tree: we had therefore met with both of these in perfection. The new pears, however, ought not to have been eaten for a month, at least, to come. We admitted, therefore, the justness of a remark of M. Van Mons, that we had tasted them to disadvantage. When we had expressed our approbation, qualified in this way, he signified to us his belief that very many of the new pears were equal in quality to those we had tried, and not a few superior. He particularly praised the Napoleon, the Marie-Louise, and the Beur-ré d'hiver de Mons, raised by M. Duquesne; and the Bosc, the Thouin, the Duquesne, the Diel, the Coloma, the Knight, and the Salisbury, raised by himself. He mentioned likewise the Sabine (named in honour of the Secretary of the Horticultural Society of London) as a fine new kind; and told us that he had given to a very large and excellent dessert pear the name of Sinclair, in honour of the great English agricultural improver*. He hinted his intention to publish a *Carpologie* (or rather *Pomologie*), in two volumes octavo; but the numerous and various duties of his new professorship at Louvain will probably occupy him exclusively for some years. Although the session is short, continuing little more than two months, yet both teachers and students are kept exceedingly busy: during the last session, M. Van Mons told us, he commonly lectured five or six hours a-day, and the subjects were not only chemis-

* It is scarcely necessary perhaps to mention, that the *Knight* pear is so denominated as a mark of respect to the distinguished President of the London Horticultural Society; and the *Salisbury*, in honour of the botanist of that name. The *Diel* celebrates a voluminous German writer on apples and pears. The *Bosc* is named after the director of the Royal Nurseries at the Luxembourg; and the *Coloma*, after a botanical cultivator at Malines, whose collection excels in succulent plants.

try, but medicine, agriculture, horticulture, and still other branches of knowledge.

Highly interested by his lively conversation, we very readily accepted an invitation to meet him at his nursery-garden in the afternoon.

It having been recommended to us, to visit the garden of *M. Piers*, a retired merchant of Ghent, who had formed a fine villa after the English style near Lacken, where he is extremely successful in cultivating Magnolias, we made inquiry at some of his acquaintances, and were informed, that we had only to send in our names, with notice of our object, in order to our being well received. We accordingly took a fiacre, and drove to the gate; but were refused admission. On requesting that a card from us should be presented to *M. Piers*, we were told, in the English fashion, that he was not at home. Our driver, a young and spirited Flemish lad, could not, unfortunately, contain himself: "Sacre nom!"—he exclaimed, with much of the naiveté of an Irish post-boy,—“ Ne l'ai-je pas vu, cette instant, passant ici devant les serres,—de mes propres yeux?—Sacre!” The door was instantly slammed. We had met with nothing like this on the Continent; and even making allowance for the irritating nature of the unlucky remark of our indignant cocher, we could not help contrasting our reception at the door of the Ghent merchant with that which we had experienced at the portal of his next neighbour and sovereign.

Gallery of Paintings, and Museum.

Thus unsuccessful in our endeavour to see the garden of *M. Piers*, we returned to Brussels, and repaired to the *Gallery of Paintings*; the extent and riches of which sur-

passed our expectations. Many a piece of Teniers and Ostade did we hastily pass;—and connoisseurs may excuse this; for we would probably have tired them out in their turn, had they been of our party, when opportunities offered for contemplating fruit-trees or crops of pot-herbs. It was easy to distinguish four large works of Rubens, which had lately been restored from the Louvre. Several young Flemish artists were now busy copying particular heads and figures from these. Painting, it may be remarked, meets at this time with great encouragement in Brussels. Mr Paelinck has acquired celebrity for historical pieces, and for full length portraits. The taste for altar-pieces for the churches creates, in Flanders, a demand, unknown to Scotland, for essays in the highest department of the art. M. De Roy is regarded as excelling most other modern painters in the delineation of animals. So numerous was the English company in the room, that it reminded us of the Exhibition at Somerset House, or rather of the more select morning assemblage to view the pictures in the Cleveland Gallery.

The *Museum*, so far as we had an opportunity of observing, is not very remarkable for excellence in any particular department. The minerals are disposed in a series of small glazed cases, each case having four sloping shelves, very well calculated to display the substances, and their name, which is always attached. The specimens are small, and only for a show-case. Of some of the minerals, we understood, there are larger and better examples in drawers below. We saw many petrifications, or vegetable impressions, in pieces of the slate-clay which covers the coal in this country: they greatly resemble those found in Scotland,—flattened reeds, galiums, small ferns, and the stem of some arborescent fern or of some extinct species of fir:

tree. A few weeks ago only, a curious specimen was procured: it consists of the petrified remains, or rather the cast of an animal, allied to the fossil ichthyosaurus of England. It was found, upon breaking a very large boulder of grey compact limestone, detached masses of which, more or less water-worn, are often met with in the sand-hills near Brussels. The interior of a ball of flint from the neighbourhood of Liege, presented the remains, or at least the cast, of an animal like a small nereis, with the impression of every joint as exact as if the figure had been cut by a seal-engraver. The collection of quadrupeds and birds is scarcely worth mentioning. The stuffed skin of the horse belonging to one of the Alberts, who governed the Low Countries in the time of the Spaniards, is still preserved here: it was shot under him in the field, and the holes made in the thorax by two musket bullets, are still very evident. In another room, we saw the model of the hydraulic engine which supplies the fountains of Brussels, and which raises 128 tons of water per minute from the Senne, to such a height as to supply the whole city. The Steenporte Fountain is the finest and loftiest, the water falling from basin to basin successively, till it reaches cisterns nearly on a level with the street. But the most noted fountain is the *Mannekin or puer mingens* by Duquesnoy, which, whatever may be thought of the delicacy of the conceit, is certainly a good piece of sculpture.

Van Mons's Seedling Fruit-tree Garden.

Accompanied by Mr Gillet (whose attentions were unremitting), we set off at the appointed hour, for the garden and nurseries of M. Van Mons. Over the door we found inscribed *Pepiniere de la Fidelité*. Before the proprietor joined us, we had an opportunity of viewing the garden.

generally, the state of the young trees, the soil, and the mode in which the cultivation of the nursery is conducted. It forms altogether an uncommon and interesting scene to the horticulturist. Many of the fruit-trees are evidently new varieties, both the foliage and bark being unknown to the practised eyes of Messrs Hay and Macdonald. In many cases, the trees have been cut in, and trained to the pyramidal shape; but being much crowded together, and having made strong shoots, they have, even where untouched by the knife, been in some measure compelled to assume the pyramidal form. A few of the trees were affected with canker, but many were quite clean and vigorous. The walks through the garden are mere foot-paths; the surface of the ground between the trees was at this time almost matted with weeds; and the whole place seems to be carelessly kept, only a simple Flemish lad being employed as gardener. The soil is light, yet rich, and, upon the whole, extremely favourable. The situation is perfectly sheltered; and young trees,—without the risk of wind-waving, or being nipped by easterly *haars* or nocturnal frosts, but enjoying an uninterrupted summer of six months, resembling the climate of a Scottish green-house,—must here advance in growth, with a rapidity and certainty almost inconceivable to those whose experience is limited to the neighbourhood of Edinburgh.

M. Van Mons having arrived, we examined the collection in his presence, and heard his explanations and remarks. Although we were prepared for something extraordinary, still our surprize was great, when we were told, that only seven years had passed since this garden was originally formed, and that some of the finest and largest trees were only between five and six years old. Many of the new pear-trees are ungrafted, or remain on their own bot-

toms; the more vigorous of these are from twelve to fifteen, or even eighteen feet in height, and yet they have sprung from seed sown in 1812 or 1813. We measured the largest ungrafted tree raised from the sowing made in spring 1812; it was fully twenty-five feet high, and the stem, about three or four inches above the soil, was a foot and a half in circumference*. Many of the pear-trees were now in fruit. The pears were of good size and appearance, especially considering that the trees were standards, and placed close together. The crowded state of the trees has been already noticed; even the larger are often not more than four feet apart, and it not unfrequently happens, that very small trees are placed between these, filling up every interstice. This must be very prejudicial, not only in robbing the soil, but in depriving the principal trees of the little room and air which they would otherwise enjoy. Those which are free from these subsidiary plants, form much finer trees.

The experience of Mr Van Mons confirms what has been observed by British horticulturists,—that the fruit produced by a seedling tree in the first year of bearing, affords by no means a fair criterion of its future merit. If a pear or an apple possess promising qualities, a white and heavy pulp, with juice of rather pungent acidity, it may be expected, in the second, third and subsequent years, greatly

* In the autumn of 1817, Messrs Thomas and Robert McKen of Troquhair sent to the Horticultural Society specimens of the fruit of a seedling pear-tree, raised from pips sown in 1810. This was the first season of fruit being produced, yet it was of a large size, nearly equal in that respect to the Epergne, or the Chaumontelle. If, in the comparatively bleak and stormy climate of Scotland, a pear-tree, in the seventh year from the seed, can yield such fruit, we need the less to wonder at Mr Van Mons's success in the course of four or five years at Brussels, where the climate is so much more genial.

to improve, in size and flavour ; particularly if the buds, leaves, bark and wood, possess the characteristics of approved bearing trees. Mr Van Mons added a remark, which we do not recollect to have met with in horticultural writings, —That by sowing the seeds of new varieties of fruits, we may expect with much greater probability to obtain other new kinds of good quality, than by employing the seeds even of the best old established sorts. Thus, if he wished to raise still more new pears, he would sow the kernels of the Sinclair, the Marie Louise, or the Diel, in preference to those of the Chaumontelle, the Colmar, or the St Germain. He likewise gave it as his opinion, that if the kernels of old varieties were to be sown, it would be better to employ those from other countries, similar in climate ; to sow, for example, the seeds of English and of American apples in Brabant, or those of the north of Germany in Scotland, and *vice versa*. He mentioned, that he seldom failed in procuring valuable apples from the seed ; for, those which were not adapted to the garden as dessert fruit, were probably suited for the orchard, and fit for baking or cyder-making. With pears the case was different ; many proving so bad, as to be unfit for any purpose. He has chiefly applied himself to the more difficult department ; for he has many more new pears than apples. We saw several beds of young seedling pear-trees, only in the second year from the pip, but all possessing promising characters.

Besides numerous seedling trees on their own roots, Mr Van Mons has many new kinds grafted on older stocks. Whenever a seedling indicated, by the blunt shape, thickness and woolliness of its leaves, or by the softness of its bark and fulness of its buds, the promise of future good qualities as a fruit-bearing tree, a graft was taken from it, and placed on a well-established stock : the value of its fruit

was thus much sooner ascertained. These make comparatively dwarfish trees, when viewed beside those that are ungrafted.

In a few cases, we perceived, what had not escaped Mr Van Mons, that where the new seedling kinds had been grafted on branches of trees of well-known old varieties, in place of young stocks, the engrafted branches were healthy and clean, while the other branches of the same trees were cankered and foul; facts which seem to illustrate and confirm Mr Knight's doctrine as to the limited duration of the vigour of fruit-trees.

We here saw one of the most uncommon efforts in the art of grafting, that of inserting an entire tree on the stump (*souche*) of another. A neighbour having, in the spring season, cut down an apple-tree, about fifteen feet high, which Mr Van Mons considered as a desirable kind and a good healthy tree, he immediately selected a stock of similar dimensions, and, cutting it over near the ground, placed on it, by the mode of peg-grafting, the foster-tree; supported the tree by stakes; and excluded the air from the place of junction, by plastering it with clay, and afterwards heaping earth around it. The experiment succeeded perfectly; the tree becoming, in the course of the second summer, nearly as vigorous as ever.

The garden is bounded on one side by the buildings belonging to some kind of manufactory. One of the favourite new varieties of pear-trees, the Diel, is here trained against the wall: it has borne, for several years past, about a hundred fine large fruit every season; and it now looks extremely well. While we were admiring this tree, some girls, with their work-baskets, passed through the garden; and we learned, that all the people belonging to the manufactory actually use it as a thoroughfare; yet Mr Van

Mons assured us, that neither his fruit nor his flowers are ever touched by the passengers. Fruit is here no great prize; but in our own country, we fear, a garden so circumstanced, would soon be destroyed, from the sheer love of mischief.

Mr Van Mons attends to other branches of horticulture besides the raising of fruit-trees. He shewed us a low frame adapted to receive glass covers, from which three crops of celery have this year been already procured; and a fourth is in progress. The celery however is small, and scarcely in any degree blanched, being intended only for soups.—Nor has he been altogether inattentive to the raising of ornamental plants, particularly roses. Of these he possesses a very considerable variety; and in this favourable situation, they spring-up so readily, that he enjoys every advantage for prosecuting their culture. He pointed out to us some seedling rose-bushes, many of them with the leading shoots nearly a foot high, which had sprung from seeds sown in March last (1817), after the heps had lain in his repositories for more than a dozen of years.

Before we parted with this enthusiastic horticulturist, he obligingly and readily yielded to our request that he would send some cions of the new and approved varieties into Scotland, at the proper season of the year*.

We now proceeded to the messagerie, and having found the conductor of a return voiture and pair for Lisle, made a bargain with him to take us thither for 60 francs,

* According to promise, Mr Van Mons sent to Edinburgh, early in April 1818, a very considerable collection of cions from his favourite pear-trees, including those the fruit of which we had tasted and approved, and several others which he had mentioned to us as yielding fruit of still superior quality.

The

stopping one day at Enghein, and another at Tournay, if we should so incline. Having reduced this engagement to writing (a precaution which should never be omitted) we

The following names were written on tallies attached to the respective pear-tree cions.

Drapier d'été	Paridaens d'hiver
Wurzer d'automne	Bergamotte Heems
Bouvier d'automne	Avant-fleur
Linden d'automne	Jaminette
Napoleon	Wurtemberg
Marie Louise	Bon Chretien du Rhin
Beaudelet	Bon Chretien fondant
Parmentier	Coloma d'hiver
Van Mons	Adan
Darimont	Beurré royal
Incommunicable	Ma fille
Capiaumont	Augustine
Belotte	Chomel
Passe Colmar	Salisbury
Duhamel	Sabine
Inconnue Argenteau	Neill
Inconnue Lille	Hardenpont d'hiver
Canning (vrai)	Delices d'Hardenport
Noir chair	Hardenport de printems
Cramoisine	Baron d'hiver
Cadet de Vaux	Knight d'hiver
Bourdon du Roi	Decain (Duquesne) d'hiver
Doré de printems	Haeghens d'hiver
Marechal d'hiver	Carels d'hiver
Bretagne Colmar	

In passing, it may be remarked, that Mr Van Mons having named one of his new productions of a former year after the Secretary of the London Horticultural Society, had probably thought himself called upon to do the same honour to the Secretary of the Caledonian Horticultural Society. "M. Neill me pardonnera," he writes, "d'avoir inscrit de son nom une poire nouvelle que j'ai obtenu cette année" (1817, when the deputation visited Brussels), "et qui est une des meilleures que mes recherches m'ayent jamais offertes."

Besides

took leave of our good friend Mr Gillet, and proceeded homewards to make preparations for our departure.

Besides the pears, Mr Van Mons sent cions of more than thirty kinds of apples, from young trees raised from the seed, most of them by himself, in the same manner as the pear-trees. All of these he considers as of good or highly promising qualities, and several of them as likely to be well adapted to the climate of Scotland. The following were the names communicated.

Reinette Bernard	Keiser
Pepin Duquesne	Bel Ecosais
Reinette Diel	Belle-fleur Stoffels
Cazin	Du Petit Thouars
Reinwardt	Prince de Waterloo
Reinette Bosc	Princesse Anne
Calville Kops	Keinkhardt
Pepin Devos	Ransteben
Mincklers	Pepin Ringler
Reinette Michaux	Pepin Cels
Calville Bosc	Reinette de Geer
Calville pepin	Pepin Cork
Pepin Seyhers	Pepin Henckel
Gripstone	Vertue
Reinette Drapier	Bouvier
Pepin Meuris	Pepin Kickx
Prince-Royal	No. 159. (pas encore nommé).

The cions had been well packed in moss (hypnum and sphagnum), and arrived in good order. Some rows of healthy and well-established stocks were appropriated to their reception, in the nurseries of Messrs Dicksons and Co. Leith Walk, and in those of Messrs Dicksons Brothers, at Broughton. All of the cions afforded two grafts, and some of them three. In both places, the grafting was performed with great care. As the cions had necessarily been exposed to a certain degree of drying or shrivelling, a practice sometimes adopted by the cautious horticulturists was resorted to: after the grafts had been put on, tied and clayed, the earth of the alleys was drawn up towards the plants, so as to cover not only the stocks, but the clay-ball, and even one-half of the graft itself. This accumulation of soil, not only prevented the clay from falling off, but kept the whole in a moist and fresh state. Owing to this precaution, the severe drought which took

We may remark, that, in the course of our walks in Brussels, we met the Duke of Kent, in one of the narrow streets, himself driving a curricle, with his livery servant seated beside him. Curiosity led us to view the house of his Royal Highness; and we were not a little scandalised to find him lodged in an antiquated building, bearing more resemblance to the offices of an old manor-house than to the palace of a Prince; while Holyroodhouse, one of the most palacious dwellings belonging to the Crown, remains without a tenant. We were no less surprised to behold the dull, ruinous mansion of Lord Kinnaid, when we reflected that for this sorry accommodation he had abandoned Rossie Priory in the Carse of Gowrie!

From Brussels to Enghien.

Sept. 12.—Before six in the morning, we bade adieu to Brussels. For some miles the road was lively and pleasant, small gardens and orchards occasionally pre-

place in the month of May of that year, produced no bad effects. On the contrary, the object was almost fully attained, some grafts of all the kinds of pears having succeeded, and only two of the apples (the Pepin Meuris and Klinkhardt) having ultimately failed. The summer proved peculiarly favourable; and in the beginning of autumn, many of the shoots exceeded two feet in length. Specimens of most of the young trees are still preserved in the nursery grounds mentioned; but the want of an Experimental Garden, under the immediate direction of the Society, where such trees could be particularly attended to, and brought to a bearing state, must be abundantly obvious to every reader. Several of the kinds have already for two years been cultivated in the gardens of different members of the Society, and we may soon expect to see their fruit. Most of the pears will, in our climate, require a wall with a southern aspect; and some of them, we are persuaded, will be found highly deserving of it.—For lists of the pears which may still be procured by members of the Society, from the Leith Walk Nurseries, and from those at Broughton, see Appendix, No. VII.

senting themselves on both sides of it. The sun shone bright, and the air was agreeably warm. We encountered a good many peasants driving their light carts to town, with small cargoes of butter and cheese; and met others on foot, hurrying to market, with broad shallow baskets of fruit on their heads; the fruit consisting chiefly of plums, pears, and apples.

As we receded farther from Brussels, the road became somewhat dull from its uniformity. We looked in vain for the country-seats of proprietors, and could only now and then descry a tolerable farm-house, distinguished by a vast barn, which in general would easily contain within its capacious interior the dwelling-house and all the other offices. The fields were still sufficiently large, but regular inclosures ceased to appear. The land seemed in general to be good, but it was evidently ill cultivated, being overrun with quick-grass. We noticed much land in fallow, and we understand that this is common after rye. But such fallows! The ground seemed to have been ploughed only about three inches deep, and the people were now poking at the surface with the hand-hoe, thus leaving the deep-rooted perennial weeds in possession of the soil. We have reason to think, that much of the corn-land is occupied by tenants destitute of capital; and while this continues to be the case, no great improvement of the agriculture can be expected.

The wheat and rye harvest was universally over; but in many places the crops of oats and barley were still green, having apparently been late sown. We saw only two or three *stacks* of corn, the common practice of the country being immediately to house the produce of the field in those huge barns which have just been mentioned. Hop-plantations were not uncommon; but they were in general of

small extent. The plants were trained from twelve to twenty feet high, and were covered with fruit. Medlar trees were scattered here and there in the hedge-rows, and bore considerable crops.

Small votive altars now became frequent on the road-side. To these our French postilion paid no sort of obeisance ; but we noticed waggoners and foot-travellers lifting their hats at passing them. These structures afforded evidence, not only of the superstition, but of the poverty of the people. Some of them did not exceed in size a common sentry-box, and were built in a very coarse and flimsy manner. In Scotland, better structures could be reared for 20s. or 30s. The upper part, in front, is either glazed, or protected by an iron-grating, and contains the effigies of some saint. We had the curiosity to examine one, dedicated "to the honour of God and St Hubert," by a man and his wife, who, it would appear, dreaded the effects of the bite of a dog supposed to have been mad, and thus propitiated St Hubert, the guardian from such calamities. In the interior of the shrine were awkward figures, in some sort of paste-work, of the saint bound to a stake, accompanied by a dog and a stag. Underneath were the words, "St Hubert, priez pour nous." A small wooden box, with a slit for receiving money, is a common appendage.

The roads were every where pretty good. We now found that the thunder-storm of the night before last had been very local. Only slight showers had fallen at Brussels: about half-way to Enghien, the road was for some miles quite miry and spotted with little pools of water ; as we approached Enghien, however, it again became dry and even dusty ; and on our arrival at this town, we learned that there had been no rain here for some time past.

ENGHIEN.

We had no sooner reached the inn, than we discovered that the Duc d'Areberg had, with the most considerate politeness, sent to Mr Chatillon, the manager of his Enghien estates, notice of our intended visit. This gentleman almost immediately came, and invited us to view the garden and grounds, and to spend the day with him.

Duc d'Areberg's Seat.

This had evidently been a very splendid place about thirty or forty years ago. But, in the course of the Revolution, the Duke having naturally adhered to the ancient regime, the Enghien estate was made free with. On the approach of a large French army to Brussels, the chateau was converted first into barracks, and afterwards into a military hospital. A still worse fate overtook it; for, a contagious fever having broken out in the hospital, and many soldiers having fallen victims to the malady, the building, instead of being purified by fumigation, was literally burnt down and demolished,—with the exception of a single lofty tower, which still remains, and gives an idea of the size and extent of the original structure. At a short distance a handsome wing has been left entire. This had communicated with the chateau by means of an arcade, and had probably, in former times, contained apartments for the numerous domestics and followers of the family. It is now fitted up and elegantly furnished for the temporary accommodation of the Duke himself, when he visits Enghien.

We first viewed the garden, which is situate close by the remains of the chateau. It is of great extent, and bears

unequivocal marks both of former magnificence and of recent destruction. For example, Mr Hay traced the foundations of the glazed houses, and ascertained that they had extended no less than 480 English feet in one continued stretch. As might naturally be expected, the whole had been ruined by the French soldiery. The conservatory and hot-houses had, at one time, indeed, been occupied for some weeks as stables by a regiment of cavalry! The horticulturist may easily conceive the devastation which inevitably followed. We figured to ourselves, while we were traversing the ruins, hungry horses browsing on such of the exotics as suited their palates; others tied to rare trees brought from tropical regions, fretting, while they were rubbed down by their rude and warlike masters; and these last hastening the work of destruction by acts of wanton mischief.

Since the expulsion of Buonaparte, the Duke has been busily employed in restoring the garden and its various appendages. Already three of the glazed houses are completely restored, each above sixty feet long; and all of these are apparently destined solely for the cultivation of ornamental plants. One of them is a stove, and the other two are green-houses. They have, we understand, been somewhat improved; and they are decidedly of a better construction for the purpose in view, than any we have yet seen on the Continent. They already contain some excellent plants; but it will require many years to form a collection equal to that which was lost.

In the stove were large plants of the broad-leaved and of the narrow-leaved *Eugenia* (*E. malaccensis* and *jambos*). The *jambos* was now in flower; and it is expected this year to produce its fruit fit for the table. The gardener

mentioned to us, that he found great difficulty in propagating the *E. malaccensis* ; but that he had succeeded by passing wires firmly around the lower branches, so as to pinch them, and then laying them in the earth along the sides of the pot or tub, and securing them by pegs in that situation.

In one of the greenhouses were several excellent specimens of Cape of Good Hope plants ; particularly a very large fan-aloë, *Aloë plicatilis*, var. *major* ; and *Aspalathus Chenopoda*, of great size, being one of Thunberg's original plants. The green-tea and the bohea-tree plants were not only in flower, but some of them shewed the fruit, which we had never before met with. The plants were now shaded from the scorching rays of the sun by means of light canvas screens, and in one instance by an upright partition of deal-boards placed in the middle of the house. But, influenced perhaps by the practice of our own country, we were inclined to think that all the greenhouse plants would be much the better for being placed abroad in the open air during the summer months, instead of being confined under glass, as here practised.

A separate smaller greenhouse, appropriated to American plants, has likewise been completed ; and it is already stored with several transatlantic rarities. Most of the wall-trees and many standard fruit-trees were destroyed ; but young ones have been planted, and are now making rapid progress.

Most noblemen, we are persuaded, would have begun by rebuilding the mansion-house, and treated the garden as a secondary object ; and very possibly the expences of the one might long have prevented the accomplishment of the other. While, however, the Duc d'Arem-

berg has thus, in a signal way, evinced his predilection for gardening and botany, he has at the same time, we think, consulted both his interest and his pleasure. He can now immediately enjoy the fine Park of Enghien, as an occasional residence: some years must necessarily elapse before the garden can be in a productive state as to most kinds of fruit, but still it is in progress; and by the time that the fruit-trees approach maturity, he may find it convenient to incur the expence of rearing a chateau.

In front of the large glazed houses, are the remains of two parallel ranges of forcing pits, adapted for producing both fruits and culinary vegetables. These ranges are of the extraordinary length of 530 feet, and had contained, in all, fourteen pits. Two or three of these pits have likewise been restored, and were now filled with ananas plants. The construction of the pits seems good, and we were told that they had, in former days, been found completely to answer their purpose. A narrow path passes in front as well as behind, in the interior of each pit; a useful accommodation to the workmen not always attended to by garden-architects.

The green chasselas grape-vine (*chasselas musqué*) is trained along the front of the house possessed by the chamberlain. It now presented a good many scattered bunches, forming a tolerable crop, if due allowance be made for the unfavourableness of the season; and we are told that, before the end of October, the grapes seldom fail to ripen fully, and to acquire their musky flavour. On a wall hard by, several other varieties of the vine appeared; particularly the small early chasselas, the champagne, and the claret grape.

The peach-trees are in general healthy; and some of them, which had escaped with little injury from the ra-

ges of the French soldiery, are the largest and oldest which we have yet remarked on our tour. Some of the kinds are, the White Magdalene and the Red Magdalene; the Large Mignonne; the Mignonne double de Troyes, a small fruit; and the Dutch Peach, or Peche de la Hollande. Two or three nectarine-trees are also of considerable standing. The Large White Nectarine may be particularly mentioned, as it is perhaps little known at home: the tree is distinguished by the leaves being of a lighter green than in the other varieties; and the fruit is said to be of excellent flavour.

The best plums here are the green-gage and red-gage. The *Swiss plum* receives a good character: it seems to be the same fruit as the Prune altesse of Brussels.

The wall pear-trees had received much damage; but some of them now again clothe the portion of wall which they had previously occupied, and many young trees have been planted both as espaliers and as standards. The most interesting is the *Buerré d'Areberg*; a new pear, described as possessing very superior excellence, and, we have reason to think, highly deserving of being introduced into Scotland by the agency of the Horticultural Society. The foliage and wood resemble those of the Winter Bonchretien; the fruit is like the brown beurré, but tapers more regularly, and the skin is of a lively green colour. It is a winter pear, not fit for use till December or January. It is represented as equalling the other butter-pears in all their good qualities, and as surpassing them in this, that it never proves gritty at the core, as they sometimes do. The brown beurré, we may remark, is here and in other parts of the Continent, very generally called the Beurré d'Angleterre.

The apples consist chiefly of different kinds of rennets, calvilles, and courpendues; but the trees are almost all

young, having been mostly procured from Brussels and Louvain since 1814.

The kitchen-garden is not yet fully restored, and is therefore irregularly cropped. We saw some excellent endive, the leaves tied close together with small bulrushes, in order to blanch the centre. A little border of broad-leaved whortleberry, *Vaccinium amoenum*, was rather a novelty to us. The fruit was now formed, and we understand that it is used in the same way as cranberries. This species very seldom produces its berries in our Scottish gardens.

Mr Chatillon next conducted us into the most highly ornamented parts of the park of Enghien. We ascended an avenue lined with tall trees, leading towards a large Temple situated on an elevated spot, from which the ground declines in every direction. We had no sooner reached the precincts of the building, than we perceived that we were in the centre of the grand *etoile* of Enghien Park, the praises of which we recollected to have long ago read. The temple is of a heptangular shape, or fronts seven different ways. At the angles on every side are two parallel columns, placed about a foot apart. From the seven large centres proceed as many broad, straight and long avenues of noble trees, affording vista prospects of the distant country in all these directions; and from the seven small centres, formed by each pair of columns, proceed an equal number of small and narrow *allées*, each terminated by some statue, bust, vase, or other ornament. The predilection for *seven*, as the number of perfection, is here as remarkable as we found it at Brussels, where there are seven churches, seven public fountains, seven Doric gates, &c. The temple is moated, or immediately surrounded by a pond or circular canal. Partly with the view of securing

the retention of the water at this elevation, and partly from the idea of grandeur, the whole is cased with marble. In former times, some perennial spring, issuing at a still higher point, had been led in pipes to replenish this pond; but at present it is supplied only by rain-water. Notwithstanding of this disadvantage, it abounds with gold and silver fishes. A handsome bridge is thrown over the canal. Along the ledges of this bridge are the remains of fountains, which are no longer capable of exhibiting the beauties or the tricks of hydraulic machinery.

Mr Chatillon led us along another of the large avenues, till a spacious area suddenly opened to view. This was the orangery; and its extent and magnificence could not fail to be gratifying. Although capacious, as it lies low, and is surrounded and sheltered by forest-trees on every side, it must form an admirable summer asylum for trees from a warmer climate. It contained, at this time, in all 108 orange-trees; very many of which would be accounted large in Scotland. About a dozen of them were pointed out to us, as being above two centuries old. These, we were told, at first belonged to Isabella of Spain, when Governess of the Netherlands. They afterwards became the property of the Emperor of Germany; from whom they came to one of the Dukes of Aremberg. They were at this time disposed along the sides of the area, in rather a formal way; but it was perhaps impossible here to attempt grouping, or to avoid formality. Marble busts, vases, and other statuary ornaments are interspersed; a few of them antique, and some of them copies from the antique, admirably executed. One piece of sculpture, the subject of which we have forgotten, our conductor valued at 1000 guineas. The trees themselves have a very formal aspect, the heads, as usual, being cut into round bush-

es, like so many vegetable balloons. Two men were now employed, on step-ladders, in the work of shearing off the twigs that had presumed to discompose the rotundity of form. The apology for this sort of treatment of orange-trees, is to be found partly in ancient custom, and partly in the necessity of restraining the exuberance of growth, with the view of accommodating great numbers of trees in the prescribed limits of the winter-repository. The disposition to form numerous flower-buds is likewise thus promoted. The flowers only are sought after, being much used, not only in perfumery, but in giving flavour to sweet-meats or hors-d'œuvres. The fruit is never seen upon such trees, nor is it desired. The winter-repository, for it can scarcely be called a greenhouse, is situate at the lower extremity of the summer orangery. It is of great size, being 170 feet long, by 27 in breadth. At one end of it stands a cast in metal, of the celebrated Farnese Hercules, the ponderous figure revolving on a pivot, so as to be easily presented in different aspects.

From the orangery, a wide berceau walk, covered with hornbeams, conducts to the remains of the chateau. On each side of this covered walk are some very beautiful evergreen trees, particularly thuyas, both oriental and occidental, of uncommon magnitude.

We dined along with Mr Chatillon at the Pavilion, as the remaining wing of the chateau is now called, and were served on rich ancient plate, with such attendance as convinced us that the Duke had been very particular in directing attention to be paid to the Society's deputation.

After dinner, and as soon as we had, according to the continental custom, sipped a cup of very strong coffee, without either sugar or cream, we proposed to visit the gardens of Mr Parmentier, whose fame, as a cultivator of

rare plants, is known over Europe. Mr Chatillon kindly offered to accompany us.

Mr Parmentier's Gardens.

We were not so fortunate as to find Mr Parmentier at home; but, in expectation of his speedy return, were politely invited by his lady to inspect the collection of plants contained in a small garden immediately behind the dwelling-house. The richness and variety of this collection truly surprised us. We certainly never before witnessed so much gardening, and so vast an assemblage of exotics, in so small a space of ground. This extraordinary garden is only about 250 feet in length, and perhaps 80 in breadth. Yet in this confined space are contained no fewer than four hot-houses, in one range, extending nearly the whole length of the garden, leaving room only for a greenhouse or conservatory at the extremity, and at right-angles to the hot-houses. There are, besides, four large pit-frames, with sash-lights, which cross the ground at nearly equal distances; and between these pits are several small glazed frames, of the usual construction.

Vegetable rarities of every kind appear to be sought after by Mr Parmentier with the utmost avidity; from the gigantic *Araucaria* to the humblest of creepers. So numerous, indeed, are the rare plants, that we find it somewhat difficult to make a selection of a few, to give the botanical and horticultural reader some idea of the collection.

The assemblage of tropical plants is peculiarly deserving of praise, being surpassed, as far as we have had an opportunity of judging, only by the royal collection at Kew, and by that of Messrs Loddiges at Hackney. In one of the stoves, the cinnamon-tree of Ceylon, nearly ten feet high, forms a prominent object. Of the old genus *Amaryllis*,

there are about forty species, several of them very scarce in England, and to be found only in the collection of Mr Griffiths at South Lambeth, or of the Hon. and Rev. Mr Herbert at Spofforth in Yorkshire. Twenty species of *Passiflora* are trained along the rafters, and several were now covered with flowers. In the genera *Banisteria*, *Ficus*, and *Gardenia*, the collection is rich.

In the greenhouse, the Norfolk Island Pine (*Araucaria excelsa*) had some years ago reached the glass-roof. Mr Parmentier was not in circumstances sufficiently affluent to render it convenient for him to erect a lofty conservatory for the sake of an individual plant: he therefore judged it best at once to cut it over at the height of seven feet. Its horizontal branches are now spreading very widely; but there is no appearance of any of them sending forth a leading shoot, to supply the place of the upright stem which has been lost. Mr Parmentier has succeeded in striking some young plants from the cuttings thus unwillingly forced upon him. But it seems probable that these also will never form symmetrical plants; for they continue to exhibit all the characters of *branches* merely, without shewing the least tendency to form leading shoots or stems. The Spruce-fir, however, (a tree analogous in general character to the Norfolk Island pine), when deprived of its leader, has been remarked to make efforts for supplying the deficiency after the lapse of many years.

Clethra arborea, with finely variegated leaves, attracted our attention: it is a beautiful variety, and very scarce in England. Of the genus *Pæonia* there are no fewer than 23 species and varieties, including *P. papaveracea*, and both the pale and dark varieties of the moutan. Of *Camellia Japonica*, Mr Parmentier has procured 14 varieties, chiefly from London. In the genus *Protea* he is extremely rich,

possessing nearly 100 species. In Geranium (including Pelargonium and Erodium) he also excels, having about 250 species. His heathery is likewise very copious, embracing nearly 300 species. Of New Holland plants he has more than 400 species; and among these is a fine specimen of the warratow or *Embothrium speciosum*, a very rare plant.

The pit-frames contain many precious plants, particularly such as require a moist heat. In these pit-frames the pots are plunged in tanners'-bark. Accommodation is likewise here found for a good many tropical aquatics. One of the pits is chiefly appropriated to the inarching of tender shrubs, striking cuttings of tropical plants, and nursing seedlings of similar character. It also serves as an infirmary for plants which have become weak or sickly in the larger stoves, the warm moist atmosphere and proximity to the glass, or light, tending to restore them.

The workmen had been recently employed in cleaning the walks of this garden, by means of an implement which we have not before seen. It may be generally described as a large and broad hoe, with two handles, one before and another behind, and calculated for being worked by two persons. One man draws forward, by means of the projecting handle; while the other, by means of the back handle, steadies the machine, causing the hoe to sink in the earth, and extirpate the deeper-rooted weeds, or to skim the surface where only superficial hoeing is required. This implement must be very useful in clearing garden-walks of the annual poa and other weeds, especially where such walks are extensive; and to the Low Countries it is peculiarly well adapted, the walks being generally laid only with sand.

Mr Parmentier is bourguemestre or mayor of Enghien, and Mr Chatillon soon learned that the mayor was return-

ed to town. We accordingly found him, with a large vasculum in his hand, and his pockets overflowing with the stalks and roots of *Pyrola rotundifolia*, which he had been gathering in the park of Enghien. He gave us a most frank and hearty welcome; and immediately conducted us to his large garden, situate at the lower end of the town. This garden is three hectares, or about six acres, in extent. It is appropriated to the cultivation of hardy herbaceous plants, shrubs, and trees; and the collection of these is very ample. In the genus *Pinus*, M. Parmentier seems particularly rich. We had already seen in the glazed houses, good specimens of *P. longifolia*, *lanceolata*, *canariensis*, *halepensis*, and *palustris*. In this garden all the more hardy species are to be found; and perhaps *halepensis* and *palustris* would do better here than in the greenhouse. There are several large trees of the Italian pine, *P. romana*, a species unknown at Edinburgh, but which thrives here, and is now covered with its small cones. A species sent home by Humboldt and Bonpland from South America was likewise now in cone. Mr Parmentier calls it *P. echinata*, from the strong awns with which the scales of the cones are armed. From its flourishing high on the Andes, he thinks that it may succeed on the mountains of Scotland. One which he names *P. sumatrana*, we were rather surprised to find in the open air, thriving well: it does not, however, yield cones, but is propagated by means of layering and budding. *P. Laricio* of Corsica seems to grow freely, and to be a species deserving of attention in Scotland. Mr Parmentier repeatedly remarked to us, that the cultivation of several of the alpine species of *Pinus* had not yet been attempted on our Highland mountains, but that they well deserved to be tried. Upon our request, he readily promised

to transmit to Edinburgh the cones of *P. echinata* and *P. romana*, when both should be fully ripe*.

The double-flowered Lilac, forming a very large shrub, was pointed out to us; and we were proceeding to view other rare shrubs, when we were suddenly overtaken by a violent thunder-storm, and compelled to flee for shelter to Mr Parmentier's house. As this thunder-storm was of a character different from what we are accustomed to in Scotland, and much more striking than what we had witnessed at Brussels, a short notice of it may be excused.—A dense, black cloud was seen advancing from the east; and as this cloud developed itself and increased in magnitude, one-half of the horizon became shrouded in darkness, enlivened only by occasional flashes of forked lightning, while the other half of the horizon remained clear, with the sun shining bright. As the black cloud approached, the sun's rays tinged it of a dull copper colour, and the reflected light caused all the streets and houses to assume the same lurid and metallic hue. This had a very uncommon and impressive effect. Before we reached the Mayor's house, scarce a passenger was to be seen on the streets; but we remarked women at the doors, kneeling, and turning their rosaries as they invoked their saints. Meantime "thick and strong the sulphurous flame descended;" the flashes and peals began to follow each other in almost instantaneous succession, and the tout-ensemble became awfully sublime. A sort of whirlwind, which even raised the small gravel from the streets, and dashed it

* A box containing a liberal supply of these was accordingly received in April 1818. But the Society not having been able to accomplish the establishment of an Experimental Garden, they were necessarily distributed among different members, who possessed opportunities of giving them a trial. The seeds of *P. echinata*, we regret to add, had not attained sufficient maturity to enable them to germinate.

against the windows, preceded the rain, which fell in heavy drops, but lasted only a short time. The sun now became obscured, and day seemed converted into night. Mr Parmentier having ordered wine, his lady came to explain that she could not prevail on any of the servants to venture across the court to the cellar. The Mayor, in spite of our remonstrances, immediately undertook the task himself; and when, upon his return, we apologised for putting him to so much trouble, he assured us that he would not on any account have lost the brilliant sight he had enjoyed, from the incessant explosions of the electric fluid, in the midst of such palpable darkness. Such a scene, he added, had not occurred at Enghien for many years; and we reckoned ourselves fortunate in having witnessed it. We had to remain housed for more than two hours; when the great cloud began to clear away, and to give promise of a serene and clear evening.

During the continuance of the storm, Mr Parmentier entertained us, by producing several valuable continental publications, connected with botany and horticulture, some of which we had not before seen, and which we now turned over by candle-light. He likewise permitted us to examine a MS. catalogue of his collection of living plants, which he purposes soon to send to the press. His great object in publishing it, is to facilitate exchanges of rare plants, with foreign amateur cultivators; his catalogue showing what he possesses, and may probably be able to send to others, and of course indicating at the same time his own desiderata. But he has contrived to render it otherwise useful. By means of abbreviations, he points out, in a single line, the Linnean class of the plant; its native country; its general nature, whether woody, perennial, biennial, or annual; the temperature which it requires,

whether that of the hot-house, greenhouse, or open air ; the mode of propagation, whether by seed, dividing the roots, layering, budding, or grafting by approach ; and lastly, he even indicates the soil best adapted for the plant : this last object he accomplishes by making A signify two-thirds light garden-mould, with one-third moor or heath soil ; B, one-third garden-mould, with two-thirds heath soil ; and C, bog or heath soil, with a considerable intermixture of sand *.

For more than twenty years past, Mr Parmentier has devoted himself to the cultivation of plants. Even since the peace of 1814, he has introduced more than a thousand species which were never before seen in the Low Countries. He has raised from seeds sent to him by the celebrated traveller Baron Humboldt, several curious plants, besides the pine already mentioned : specimens of these he has furnished to the Jardin des Plantes at Paris, and to the Botanic Garden at Berlin. At Brussels, there are no facilities for the publication of figures or descriptions of nondescript exotics ; and this disadvantage is very sensibly felt by so zealous a cultivator as Mr Parmentier †.

* In the summer of 1819, M. Mary, a nephew of the Mayor, visited Edinburgh ; and on that occasion we received from him, both a printed copy of his uncle's catalogue, and of a small but valuable statistical work, entitled, "Exposé succinct des produits du regne vegetal et animal dans le Canton d'Enghien." This work is divided into two parts. In the first Mr Parmentier treats of the general state of husbandry, the soil, the crops, &c. and the animals reared : In the second, of the products, vegetable and animal, and their respective values. The minutely accurate local knowledge which he displays in this work, along with enlarged views, where these can be introduced, prove him to be one of the most intelligent of magistrates that any country can possess.

† Till lately, the cultivators of curious plants in Scotland laboured under the same disadvantages. The great distance prevented the sending of new

On inquiry we found, that there are, in the neighbourhood of Enghien, two or three small nurseries for forest-trees, but not one establishment of any kind for the rearing or sale of fruit-trees.

Having taken leave of Mr Parmentier, we returned to our inn, after declining a pressing invitation of Mr Chatillon that we should spend the night at the Pavilion.

From Enghien to Tournay.

Sept. 13.—We set off betimes for Ath. Tobacco gardens and small tobacco fields now began to appear. We are aware that this plant is an object of culture in some parts of Holland; but we did not happen to fall in with any of the tobacco-plantations of that country. The plants nearly covering the ground with their large lanceolate leaves, seemed ready for being gathered and dried. We passed several extensive, but now burnt-looking, fields, which had this year borne crops of poppies, which are here cultivated for the sake of the oil which may be expressed from the seeds. Rape also seemed a common crop, and the procuring of oil from the seeds is likewise the principal object. Near *Ath* we noticed an inclosure-hedge, composed wholly of *Robinia glutinosa*. We breakfasted at the fortified and frontier town just named, and afterwards walked about it for an hour; but we saw no gardens worth notice, and only remarked

or rare plants in flower, to the editors of the excellent "Botanical Register," or of the long established "Botanical Magazine." The quarterly publication of "The Exotic Flora," by Dr Hooker of Glasgow, will, we doubt not, operate as a stimulus to cultivators in this country: and they ought never to hesitate in availing themselves of such an opportunity; for they may be well assured, that new or rare plants, if sent in pots, will be well taken care of and safely returned, and that they will be published with all the advantages which a first-rate botanical describer and excellent artists can confer.—N.

that the Government is busily employed in improving and enlarging the fortifications.

On our way to Tournay, we found that much more rain had yesterday fallen in this direction than at Enghien; and before we reached that noted town, showers had again begun to descend.

TOURNAY.

After dinner, finding every place wet and dreary, and the inhabitants housed, we paid a short visit to the celebrated limestone quarries, from which great quantities of stone, under the name of Tournay Marble, are sent by canals to every part of the Low Countries. The admirable pear-trees which we saw clothing the ramparts, the walls of houses, as well as the inclosure-walls of gardens, on the outskirts of the town, convinced us, that this is a place worthy of the particular attention of the horticulturist. But we were reluctantly compelled to abridge our examination of these gardens; for the weather, instead of improving, became worse, so that we could not, in decency, ask the possessors of the gardens, to expose themselves to it, and we disliked passing through the gardens unattended.

Pear-tree Gardens.

As a proof of the celebrity of Tournay for the production of fruit, we may mention, that the Botanical and Horticultural Society of Ghent last year offered a premium for the best explanation of the causes of the superiority in size, beauty and flavour, of the fruits produced at this place. The gardens are not merely, or even chiefly, those of amateurs, but of practical cultivators, who send their produce to Brussels, Amsterdam, and other distant places. One of

the most distinguished cultivators is M. Rutteau ; and we make no doubt that he will correspond with the Society as soon as our Experimental Garden is established. Autumn and winter pears are the chief productions ; and next to these apples. All the fine late pears are trained to the wall, and as carefully attended to, as peach-trees are at Ghent, Brussels, and other places. The autumn pears, such as crasannes, beurrés of different kinds, and doyens, fill the western aspects ; while the winter pears occupy the southern. Of these, we understand, the St Germain, the Passe-Colmar and common colmar, Bon-chretien, Martin sec, virgouleuse and bezi de Chaumontel, may be accounted the chief. We heard of no novelty, unless the *pass-colmar* be reckoned such : indeed, we are led to believe, that the horticultural excellence of Tournay consists principally in the successful cultivation of known and approved kinds. All these finer pears are here very generally grafted on Portugal quince stocks ; and they are grafted very low, generally close to the surface of the ground. The quince, it may be noticed, does not push down a tap-root like the pear, but spreads out its roots. This mode of growth is well adapted to the soil at Tournay, which consists of a layer of sandy loam, approaching in its character to light vegetable mould, in most places we believe comparatively shallow, and lying immediately over the beds of limestone or marble, which must necessarily communicate a sufficient quantity of calcareous matter. The whole seems remarkably free from hurtful impregnations of iron. The gardens were at this time covered with water, owing to the heavy rains ; but we understand that the soil is not found injuriously retentive of moisture, but only desirably damp and cool. The general situation is excellent. The town and its gardens are sheltered from the coldest

winds, by the rising grounds or hilly ridge called Trinity, and they are further protected on every side by the wooded state of the country around. The period of blossoming is commonly a fortnight earlier at Tournay than at Ghent or Brussels; yet the blossom seldom suffers any check. The gardens are very generally inclosed in part by walls, from ten to fifteen feet in height, which is quite sufficient for the training of pear-trees grafted on dwarf-stocks; and the rest of the inclosure frequently consists of tall hedges of hornbeam. Several of the gardens are immediately in front of the ramparts, which are between forty and fifty feet high; and the largest and finest pear-trees are trained against these. Some of the rampart trees are evidently of great age: they fortunately seem to have suffered nothing from any warlike preparations during the troublous period, and they are now in high condition. Though this has been an unfavourable season, they seem to offer a fair crop. The trees are trained chiefly in the horizontal mode, or in a modification of this mode, with the fan style.

From Tournay to Lille.

Sept. 14.—The morning having brought no improvement of the weather, we were obliged to set forward to Lille, without accomplishing a more minute examination of the Tournay gardens. This is the most serious disappointment we have met with in the course of our little tour.

About three or four miles from Tournay we entered the French territory, the line of demarcation being marked out by posts, and by a ticket on the road-side, intimating that the *droits de l'entrée et de sortie* there become exigible. Our portmanteaus were slightly examined at the first vil-

lage, and sealed by the officers, so as to supersede the formality of a second examination at Lille.

At this part of the road the crops assumed a different aspect. A kind of coarse reddish colewort, known here by the name of *caulet*, occupied many fields. It is evidently an additional variety of the *Brassica oleracea*, which none of us had ever before seen. Having stopped the carriage, and gone into a field to examine it, we learned from some work people, that it is used solely for the feeding of milch cows; and from the size of the plant and luxuriance of the foliage, it seems well adapted to this purpose. At present, we believe, it is almost peculiar to this part of the country; but seeds of it might easily be procured, either from Tournay or Lille. Mangold-wurzel or *betterave champêtre* is likewise extensively cultivated: the lower leaves had already been cut off for green fodder, and the roots are, some time after this, stored for winter provision. From seeing scattered plants of madder or *garance* (*Rubia tinctorum*) along the margins of the fields, we conclude that it is occasionally cultivated. Great quantities of the common garden-cress are here grown in the fields, for the sake of the seed, which is in constant demand for the purpose of raising the plant in gardens as a salad. The remains of extensive crops of white poppy every where appeared. The cut poppies were, in some places, tied in small sheaves, five or six of which stood together. In other places, women were engaged, with sheets spread on the ground, in beating out the seed with repeated strokes of the hand. From many fields the poppies were by this time entirely cleared. The cultivation of this plant on the great scale is unknown in Scotland, but here, we are told, it yields a very profitable return to the farmer. Tobacco likewise became a frequent crop. Besides these, crops of colzat and of rape, which are

extensively cultivated in Flanders, continued to diversify the surface. Both the colzat (*Brassica oleracea campestris*), and the rape or *rabette* (*Brassica Napus*), seem to be raised, not only for the sake of the oily seeds, but also for the green leaves to be used as fodder. *Myagrum sativum* is sparingly cultivated, under the name of *Cameline*, likewise for the sake of the oil which may be expressed from its seeds. This plant often appears spontaneously in flax-fields in Scotland ; but neither it nor colzat has ever been an object of cultivation there.

LILLE.

By the time we reached Lille the sky had cleared up ; and we enjoyed a charming afternoon for viewing the town and its environs. In the appearance of the houses and of the people, we here perceived a difference nearly as striking as that which we had noticed in the crops : now every thing was French. The houses are all of stone ; and, in their general aspect, reminded us of those in the former Picardy Place of Edinburgh, built for the French refugees who came to Scotland after the revocation of the edict of Nantes, and who, it appears probable, had themselves suggested the plan of the buildings.

The *Botanic Garden* having been recommended to our notice, we went thither with raised expectations : But they were disappointed : for we found that it had been established merely as an appendage to the central school. It is of small dimensions, and had never acquired any eminence. At present it is nearly in a ruinous state ; neither the town nor the Government seeming to take any due interest in its welfare. The plants are, or rather had been,

arranged according to the natural orders of Jussieu: many blanks occur, the specimens having apparently died out, and not been renewed. A variegated-leaved *Bignonia radicans*, covering a large portion of wall, seems to be the best plant in the garden. *Passiflora cœrulea* was here fancifully trained around a large hollow trellis of wire, of an oval shape, and now displayed its flowers in this situation. We were informed, that lectures on natural history in general, are here delivered by Dr Lestiboudois, well known as the author of the "*Botanographie Belgique*;" and although the public garden is at present in a neglected state, Lille may boast of possessing another distinguished phytologist in M. Desmazieres. This gentleman, about four years ago, published a work, entitled, "*Agrostographie des departemens de Nord de la France*," in which the botanist may find an account of the native graminæ, and the agriculturist of the cultivated grains and grasses in Artois and Picardy. In turning over the pages of the book, however, a curious morsel of information for Scotsmen presented itself, shewing that the author does not always write from observation or experience, and that he partakes of some of the prejudices of Dr Samuel Johnson. Speaking of the *Avena sativa*, he mentions, that bread may be made from the seeds, but he affirms that it is "*noir, amer, visqueuse, et se digere difficilement!*" We may safely conclude, that M. Desmazieres has never been in the Land of Cakes, nor seen good oaten bread, which is certainly neither black, bitter, tough, nor difficult of digestion; even *scones* made of bigg-flour and pease-meal not deserving all these objurgatory epithets. The Scottish peasants, he immediately adds, although they use no other grain, "*sont pourtant tres-robustes et tres-forts*,"—a fact which might

have induced him to institute some inquiry into the real qualities of their favourite food.

One of the best private-gardens here, is that of M. Mallet. But Lille does not seem to excel in fruit-trees, nor in other horticultural productions; and we felt regret that we had not enjoyed this delightful afternoon at Tournay.

We now walked along a beautiful public Promenade, shaded by trees, and proceeded to the Citadel, accounted the chef-d'œuvre of the great military engineer Vauban. In returning along the ramparts, we came to a rising ground, which has long been known by the title of Mount Calvary. During the revolutionary period, a large crucifix, which stood on the eminence, had been destroyed. It has of late been replaced by a new one; and when we passed, some hundreds of people, many of them well dressed, were kneeling upon the grass bank in front of it, at their evening devotions.

All around Lille are numerous windmills, the greater part of which are employed in the expressing of oil from the seeds of poppy, colzat, rape, and other plants. The finer and purer part of the poppy-oil, we learn, is used for culinary purposes; being, when fresh, thought little inferior to olive-oil. A great deal is consumed in the cloth manufacture. The coarsest and least pure portion serves for burning in lamps. As the colzat-oil is generally rather thick, its use is chiefly confined to the woollen-manufacture, and to the making of black or soft soap.

From Lille to Paris.

Sept. 15.—We left Lille in the morning, being anxious to get forward to Paris.

We stopped a short time at *Arras*, the capital of *Artois*; examined the fruit set out for sale on stalls, or to be

found in shops; and took a view of the Old Church, which was built by the Spaniards. In this neighbourhood, poppies and tobacco seem to form the staple crops of the farmer. We passed many hundred acres of both, but the poppy fields in general were the most extensive. The poppies had in a great measure been cleared off; and the people were now engaged in drawing the tobacco plants. In cultivating tobacco, the central part of the plant is cut out, leaving only six or eight of the exterior or lower leaves: this mode of treatment, preventing the pushing up of a flower-stem, naturally causes the lower leaves to swell in size. When seed is wanted, the operation of centre-cutting is of course omitted, and the plants are allowed to spire. All the fronts of the houses in the villages through which we passed, were now hung with tobacco leaves, strung upon twigs and cords, in order to their drying. We scarcely recollect to have noticed any fallows in the Low Countries; but now they appear in every direction.

In the Netherlands we had seen the crops nearly all housed; but between Arras and Corbie a good deal of oats and barley still remained uncut; and much more had been cut down, which was still lying in the fields.

Sept. 16.—We this day continued our journey through Picardy. *Amiens*, the capital of the district, offered no novelty in the way of fruit. It is a very ancient looking town, finely watered by the Somme and its branches. The streets are paved with sandstone, as is the case in all the other towns in this part of France. Although a vast deal of land is under crop in Picardy, and the corn-fields are of great size, yet no farm-houses are to be seen: for a dozen of miles together, you have the appearance of one interminable farm. This, at first, seemed extraordinary; but we

soon learned, that the cultivators prefer living in villages, society and the evening dance being nearly as indispensable to them as their daily food. If the farm be distant, the husbandman, and his servants, of all descriptions, set off early in the morning, in a light waggon, carrying with them provisions for the day. Rich sheep-pastures are intermixed with the corn-lands, and often without any kind of inclosure. Sheep-husbandry seems to be much attended to; and here things were quite in the oriental style. The shepherd walks *before* his flock; at night he guides them into a fold; for himself he has a moveable thatched hut, which he pitches close by; here he reposes, with the watchful dog at his feet. These precautions are necessary, on account of wolves, which are still common in Picardy. The old pastures were now beautifully decked with the flowers of the colchicum or purple autumnal crocus, which the sheep never touch. In many places, a line of cider-apple trees ornaments each side of the road: the crop of apples is this year scanty, and there will be a great deficiency in the quantity of cider produced.

Towards *Mont de Dieu* the country became somewhat higher, with extended elevated plains, on which black cattle were feeding. For many a dreary mile not a house was to be seen, the people, as already remarked, crowding together in small villages in the hollows. We passed through one of these, where detached mud-built cottages irresistibly conveyed the idea of poverty; but the houses were intermixed with trees, corn-stacks and cottage-gardens, while a pure streamlet made its way down the centre of the street,—giving the village altogether a pleasing irregularity of appearance, which partly atoned for its apparent want of comfort. A French fellow-traveller mentioned, that this village was almost depopulated by the folly of Louis XIV. in

withdrawing protection from the Protestants in 1685: he added, that there are still a good many Protestants in it, but no reformed place of worship.

At *Clermont* the country and the climate began to improve. Here we first saw grapes on standard vines, and on vines so trained as to form arbour-walks. On some chasselas vines trained to the walls, the bunches were now of considerable size. We soon afterwards came to Chantilly, and took a hasty view of the remains of the superb hunting seat of the Prince of Condé. In former times the park was more than twenty miles in circumference, and abounded in feathered game, particularly the red partridge and the quail. The park seems to have been partitioned and subdivided during the revolution; but much of the fine wood remains. We entered one of the avenues leading to the *grande étoile*, and were delighted with the beauty and vigour of many of the trees. A suite of buildings, the extent and grandeur of which attracted our notice, we ascertained to have been the Prince's stables and offices. They are now partly converted into dwelling-houses. The celebrated ancient garden of *Le Nôtre* and the modern English garden of *Le Roy* seem equally to have suffered dilapidation: but we had not time to make particular observations. Beyond the Park properly so called, there is a forest of great size, extending eastwards, where the royal parties used to hunt the marcellins or young boars.

At *Luzarches* we procured some bunches of white muscat or Frontignac grapes, but they were not ripe, nor so good as might be procured at Edinburgh, though certainly cheaper. We now entered on the northern confines of vineyard-plots or *vignobles*, in this direction from Paris; for they extend farther north on the Calais route. Among the varieties of vines cultivated in these, we could recog-

nize the Dusty Miller and the small Black Cluster, both commonly trained on walls of houses in England. Banks sloping to the south or the west, seem commonly preferred for the vine-plantations. The plants or stools are placed pretty close to each other, in rows: but the rows are wide, allowing plenty of space for the vigneron to pass along in dressing the plants: very commonly a line of haricots, peas, or other legumes, appears between each row of vines. The vine-plants are permitted to rise only between three and four feet high; so that a vineyard, in the North of France, does not make a much better appearance than a field of drilled beans in England, and is certainly very inferior in effect to a hop-plantation in Kent.

As we approached *St Denis*, the vine-plantations increased in number and in size, extensive hillocks being now covered with them. Very little fruit appeared; and we learned that the scantiness of the crop was universally complained of, the blossom having, this year, been injured by cold winds, and long continued rains.

PARIS.

Sept. 17.—We took up our abode at the Hotel de Boston, Rue Vivienne, near the centre of the French capital, where we found ourselves pretty comfortable. Having hired a fiacre by the hour (40 sous for the first, and 30 for each subsequent hour), we procured our letters at the *poste restante* of the General Post-office in Rue Jean-Jacques Rousseau, and made calls at the houses of some friends of Mr Hay, who had settled in Paris.—In the course of the day we went to the hotel of the British Embassy in Rue Fauxbourg St Honoré, when Mr Macdonald deliver-

ed to Sir Charles Stewart, a letter of recommendation from His Grace the Duke of Buccleuch *. We were all introduced to His Excellency, who conversed some time with us on the state of horticulture in France, and particularly called our attention to the royal establishments for rearing young fruit-trees at the Luxembourg and the Roule. He expressed his confident expectation, that we would receive full permission from the French Government to enter and inspect these and the other royal gardens.

English Ambassador's Garden.

We may here notice, that the garden immediately behind the Ambassador's house was dressed very neatly in the French style, Sir Charles having in his employment a French gardener. Great use is made of the rampant, but showy *Cobbea scandens*. Along the side of the walks are placed, at intervals, a number of boxes, about a foot and a half square, and painted green; each containing two plants of the cobbea. These are trained to upright posts; and when the shoots overtop their supports, which they speedily do, they are passed in festoons, in opposite directions, from post to post. These wreaths, now richly adorned with the large bell-shaped flowers, produced a very elegant appearance. The cobbea, we find, is treated at Paris as an annual plant; being sown, in March, on a hot-bed, and planted out in the end of April. Owing to the bright and warm summer, it produces its first blossoms early enough to ensure the ripening, annually, of a sufficient supply of seeds.

Having been joined by Mr Atkin, engineer, one of Mr Hay's Scoto-Gallican friends, originally from East Lothian,

* The late Duke, who died at Lisbon in 1819.

we dined together at the extensive rooms of Champeaux, restaurateur, in the Rue des Filles St Thomas, opposite to the new Exchange. After a dessert of excellent peaches, the *tardives* being still in season, we proceeded, under Mr Atkin's guidance, to the celebrated

Palais Royal.

The spacious court of this palace is planted with several rows of limes; but these, at this period, afforded little shade: the ground is trodden hard by innumerable promenaders, and the leaves of the trees had been shrivelled by the parching heat and drought. Two grass-plats, however, surrounded by flower-borders, maintained the freshest verdure, and presented flowers of the most lively hues. But these are watered, night and morning, in dry weather, by means of a long leathern tube, connected with a fountain, and furnished with a perforated nozzle, like the rose of a watering-pot. In the centre of the court, between the grass-plats, is a small pond, with a simple, yet grand, jet-d'eau in the middle. This powerful jet has the effect of refreshing the air all around; and while the sun shines upon it, the iris which results forms a very pleasing phenomenon. Under the piazzas many females and boys were selling green walnuts; and these having just come in, seemed to meet with great demand. Vast quantities of chesnuts are also retailed here: one chesnut-girl, we are told, pays about 2000 francs a-year for a little stall under the piazzas, where she disposes of these nuts, fresh, roasted, and boiled. The best chesnuts are those brought from the neighbourhood of Lyons; but the title of *Marrons de Lyons* is, we understand, much abused, being frequently bestowed on fruit gathered from common chesnut-trees in the neighbourhood of Paris.

We entered the far-famed *Café des Mille Colonne*s, where a truly elegant bar-maid (or the presiding goddess of the place, as a Frenchman would perhaps call her) sat, decked in costly jewels, on the real throne of Louis Buona-parté ! After a *tasse* of most exquisite coffee, and a *petit verre* of delicious liqueur, we left this extraordinary place, which was rendered disagreeably dazzling and hot, by the number of mirrors, lights, and visitants. We were next conducted to the *Café de la Paix*,—a kind of operative theatre, where no admission-money is charged, but where all and sundry the audience are expected to be eating and drinking for the good of the house, while they are witnessing the entertainments. We concluded our view of the lions of the Palais, by descending to the *Café des Aveugles*, which is situate in the sunk floor of the building, and where there is an orchestra filled by blind musicians.

Descriptions of Paris being familiar to every one, and most of our readers having probably seen more of the curiosities of the French capital than ourselves, we shall pass slightly over every thing unconnected with horticultural subjects. In a daily journal, however, we cannot with propriety omit to mention—although we do little more than mention—the objects of a stranger's curiosity which we had an opportunity of seeing.

Supply of Vegetables.

Sept. 18.—Early in the morning Mr Macdonald was at the *Marché des Innocens*, situate where the street which continues the line of Rue St Honoré meets at right angles with the Rue St Denis. This was formerly the site of a church dedicated to the Innocents, and of a cemetery which came to be over-peopled. The mouldering remains having become offensive, and almost pestiferous, were re-

moved, during the sway of Buonaparte, to fields at a distance from the city ; while, to save the feelings of the living, the bones were collected, and piled in some of the vast subterranean chambers formed by the abandoned quarries of Paris, which thus acquired the name of Catacombs. The area thus cleared, now forms the principal green-market of Paris.—Many waggons with vegetables from the country, had already been unloaded ; but Mr Macdonald was in time to see the well-furnished stalls, before the retail sale of the day had commenced. He found the quantity and quality of all the kitchen-greens fully equal to his expectations.

Endive, round-leaved and slightly cabbaged, was extremely abundant, and seemed tender, though but indifferently blanched. Lettuces, of several varieties, were very good. Parsley, both curled and smooth, was plentiful. Cauliflower appeared in great quantity, and was of excellent quality. Dutch turnip-radish and black Spanish radish were very common. Summer spinage, and garden-sorrel (here called *Oseille de Hollande*) were nearly equally abundant. Leeks were slender, but tall and well blanched. Carrot, red beet, and parsnip, were all of good quality, and very plentifully supplied. The potatoes were chiefly of the kidney-shaped varieties, red and white, and washed clean. Garden beans and peas appeared in great profusion ; and numbers of young people were employed in shelling both, at the stalls in the market,—a piece of drudgery which the Scottish green-grocers devolve on the purchasers. Late cabbages appeared in the market ; but none of the fine early kinds were at present to be seen. The Savoy's were of excellent quality. Artichokes were extremely abundant, and of good size ; baskets filled with the small lateral heads were likewise brought to market,

very young artichokes being here frequently in demand. Many baskets were filled with celery tops and leaves, but no blanched stalks appeared. The quantity of very fine silver-skinned onions was remarkably great.

Some articles not usually seen in our home markets, were here very common. Among these the *navet* or French turnip may first be mentioned; it was indeed the only kind of turnip at this time in the market, and the specimens were large and clean. Kidney-beans or *haricots*, of several different varieties not common with us, were in vast profusion: the shelled beans were now most common, but many baskets of the green siliques also appeared. Hamburgh parsley roots were frequent; and as much shallot and garlic appeared this morning as Mr Macdonald thinks would serve the Edinburgh market for a year. Love-apples or *tomatoes* were to be seen on every stall. Pompions or *potirons* were numerous, and some of them of large dimensions. Large cucumbers, chiefly of the white variety, were pretty common; but the gurkins or small cucumbers, here called *cornichons*, were all of the green sort, forming, perhaps, a distinct variety; the number of baskets of these brought to market this morning appeared surprising.

Green purslane, chervil, burnet, and large-leaved lamb's-lettuce, here called *mâche ronde* or *doucette*, seemed to be the favourite salad herbs; with flowers of the Indian-cress or *capucine*.

Vast quantities of melons came to market along with the culinary vegetables, being evidently raised by the same cultivators. They were chiefly of the large netted varieties of Honfleur and Coulommiers, and not of fine quality; some rock Cantelopes, however, were very good. Baskets of grapes were numerous enough; but the bunches were in general small, and only a few of the berries on each bunch

were ripe. The grapes, therefore, fell much short of Mr Macdonald's expectations. They were chiefly of the kind called Chasselas or Fontainebleau; and we must in candour remark, that as this is the sort most generally used at table in Paris, there can be little doubt, that a month hence, when properly ripe, they will be found much superior in quality to the specimens now in the market. A few bunches, with very large berries, were probably the white Corinth grape. Some pottles of alpine strawberry, having the berries packed with the utmost nicety and neatness, caught Mr Macdonald's attention. On examination we think, that, as a sub-variety, this fruit is different from any known in Scotland. It is remarkable for its narrow and oblong shape, and for delicacy of flavour. We understand it is called the *Majausf* or strawberry of Bargemont. In speaking of the treatment of the wood strawberry at Haarlem (p. 211.) we mentioned that new plants are procured every second or third year from the woods at Boskop, the cultivated plants proving speedily exhausted. The French gardeners experience the same necessity for renewing the plants; but they adopt the more scientific and equally effectual mode of raising them every second year from seed. Seedlings of the alpine strawberry, it is remarked, are less liable to sport than those of other kinds; and they frequently yield fruit late in the autumn of the first year.

Several other sorts of fruit are also sold at the *Marché des Innocens*. Late peaches and nectarines were still pretty common, and of excellent quality. The kinds were principally the Bourdine, Teton de Venus, Rambouillet, and Nivette. They were chiefly, it is believed, the produce of Montreuil.

Jardin des Plantes.

Being anxious to take the earliest opportunity of seeing the celebrated Garden of Plants, we went thither this forenoon. We had letters of introduction to Professors Desfontaines, Thouin, Cuvier, and Lucas fils, and also to Mr Royer of the Administration du Jardin. At this time we found only the two last-mentioned gentlemen: They were most polite and attentive; and such is the liberality here shown to foreigners, that we experienced not the least difficulty in getting access to every place which we expressed a wish to view. On a first visit we could take only a very general survey of the grounds; and, Mr Royer, after accompanying us for some time through the garden, having made us acquainted with M. Riché, who is practical manager of the serres-chaudes, we thought it best, at this time, to confine our attention chiefly to the tender exotic plants. Riché has had long and great experience in this branch of horticulture; and many of the plants, by their size and healthful luxuriance, bore testimony to his being a very successful cultivator. Although considerably advanced in years, he is full of zeal and activity, and he seemed to take much pleasure in pointing out the botanical rarities under his charge.

The principal stove is of large dimensions. But at present it was in a great measure untenanted; most of the plants, during summer and the early part of autumn, being placed in the open air on a terrace in front of it. Only a very few of the plants can here be noticed. *Cordia macrophylla*, from the West Indies, was of large size, and displayed its broad foliage very beautifully. Several plants of *Pandanus odoratissimus*, or green-spined screw-pine, from the East Indies, were in admirable condition, and six or seven feet high. A large specimen of *Bonapartea juncea*

from Peru, was by much the finest of the kind we had ever seen. *Schotia speciosa* from the Cape of Good Hope made a brilliant appearance, being now clothed with its elegant scarlet blossoms. The number of sugar-cane plants (*Saccharum officinarum*) here cultivated, is considerable; and they grow very strong, one specimen being now about twelve feet in height. About ten years ago, they could afford to cut so much of the cane, that the chemists belonging to the institution amused themselves in extracting the sugar, and actually manufactured a small sugar-loaf, which was presented as a curiosity to the Empress Josephine, then in the zenith of her glory, and deservedly held in esteem as the munificent patroness of elegant horticulture.

The large *orangerie* or green-house was at this time empty and neglected; at least, it was unadorned by plants, and encumbered only by lumber. How easily might this vast house be rendered ornamental for the summer months, by means of a few showy climbers, led along the columns and rafters, and a few large exotics set out on the floor! Even festoons of *Cobbea scandens*, such as we have mentioned at the English Ambassador's, would answer the purpose. But it is the custom of the Continent to overlook the appearance of the greenhouse during summer; and a bad custom exerts its influence even at the admirable *Jardin des Plantes*. It is certain, that those who could so easily remedy the defect, must have no idea how offensive the appearance is to the eyes of strangers, especially from this country. The plants belonging to this great winter repository are, during the summer months, sunk, *en pleine terre*, to the brim of the pots, in beds edged with box, so as to resemble border-plants. In this way they require less watering, and are not liable to be overturned by gusts of wind. The flower-pots have generally

three or four small drain-holes in the bottom, instead of one large hole, as with us. This prevents the access of the larger earth-worms to the pots; and no other precaution against worms seems to be taken, except using crocks that are perfectly flat. To attempt to particularize even the more remarkable of the greenhouse plants, would swell our notices beyond all reasonable bounds. We leave them, therefore, with remarking, that great numbers of screens of basket-work, generally of a circular form, and open at one side and at top, are here used for shading such plants as have leaves of delicate texture, from the direct rays of the sun, which would speedily scorch them. This was the time of the great *rempotage*, or general repotting of these greenhouse plants, the stove plants having been already finished. In performing this operation, the French under-gardeners are not more quick, and not nearly so neat-handed as in Britain. Instead of filling in the earth with their hands as our gardeners do, they lift it with wooden spatulæ or *palettes*; the advantage of which is not very obvious. The pots are of a clumsy construction compared with ours; but they are of a soft porous texture, which must be favourable to the plants, though it by no means improves the appearance. The gardeners wear very broad but light straw-hats, to protect them from the sun's rays, during the bright and warm summer months.

In front of the garden entrance to the Amphitheatre where the public lectures are given, were now placed, in tubs, two specimens of the smaller fan-palm, *Chamærops humilis*, each measuring about 20 feet high, and of venerable aspect. M. Riché mentioned, that they originally belonged to King Francis the First, who built the palace of St Germain, and formed fine gardens there; but that he believed they had been here since the institution of the

Garden of Plants. They are to a certain extent assisted in acquiring the antique character which depends on the smoothness of the lower part of the stem; for the loose remains of the leaf-scales are yearly cleared off with care. The garden approach to the front of the amphitheatre is likewise ornamented with many fine old *Neriums* in tubs.

Mr Royer now conducted us to the Botanical Cabinet, which is situate in the upper part of the building called the Administration. We found it to be a very complete establishment of the kind, consisting of several apartments, as marked in the annexed sketch, taken from Mr Hay's note-book.

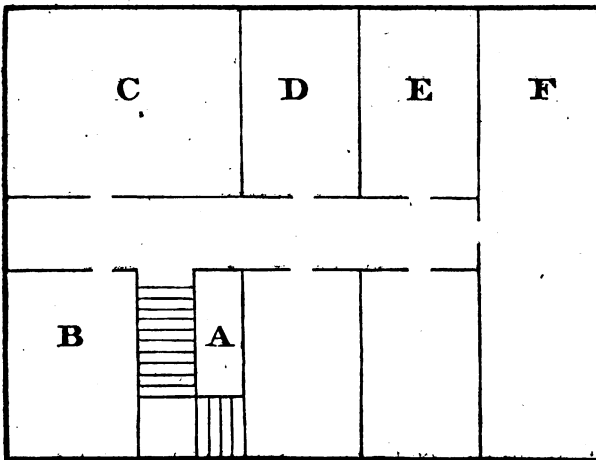

In the staircase A is preserved a tall palm-stem from South America, which had been naturally clasped in a very extraordinary way by some *liane* or twining shrub, and evidently strangled by the deeply indented grasp of its invader. Professor Desfontaines' working-room is marked B. The working-room for the Professor's assistants is

Z

at C. Here a respectable-looking female was now employed in fixing dried specimens of plants to sheets of white paper, after they had been arranged for that purpose by Professor Desfontaines. The room marked D is appropriated to the keeping of the specimens of dried plants. They are contained in close presses, and so accurately and conveniently arranged, that the specimens composing any particular genus can be produced for examination the moment they are called for. The apartment E contains specimens of the wood of very many species of trees,—we believe of almost all that are figured in the quarto volume published by Mr Sepp of Amsterdam and edited by Dr Houttuyn, and of many unknown to these laborious Dutchmen. The samples are in general smoothed with the plane, the better to display the grain, and the extreme beauty of some kinds. A vase, nicely formed out of the stem of a date-palm, is a curious object: it is about a foot and a half in diameter, and somewhat more in height. The large apartment F, extending the whole breadth of the building, contains the seeds and seedvessels of plants, with specimens of vegetable products in general. In the same room several commodious presses and drawers are appropriated to the reception of the seeds saved in the garden from the more rare or tender plants, particularly those of only annual duration. We may add, that the great attention paid to this part of the business of the garden, the saving of seeds, and keeping them in the nicest order, received our unqualified approbation. A glazed frame, containing numerous skeletons of leaves and of flowers, had a very pretty and unusual effect. Fronds of the great umbrella palm of Ceylon, *Corypha umbraculifera*, decorate the ceilings of two of the rooms.

We hope soon to see a botanical cabinet, though perhaps on a less extended scale, forming an accompaniment to our new Edinburgh Botanic Garden *.

Mr Lucas afterwards introduced us to the great museum, where the collection of stuffed quadrupeds, birds, and fishes, with insects, shells, minerals, and petrifications, occupied our attention during the remainder of our stay at the Jardin, which was prolonged till the hour of shutting the museum arrived. It is surely unnecessary to remark, that we could see little of such a collection in the course of two or three hours : it would form a pleasing and profitable study for several months. Naturalists and artists were, in different places, occupied in taking descriptions, or in making drawings ; and several pupils (chiefly young ladies) of M. Vanspaendonck, Professor of Iconography, were engaged in the same way. We were exceedingly gratified to remark the liberal principles on which the whole establishment seems to be conducted : we are perfectly convinced that any devoted and intelligent naturalist, to whatever country he may belong, will here meet with every encouragement and assistance in prosecuting his investigations.

Visit to St Germain.

Sept. 19.—We this morning hired a cabriolet to take us to St Germain en Laye, being desirous, as early as possible after our arrival at Paris, to see Mr Thomas Blaikie

* At this garden is preserved the extensive herbarium of the late Dr John Hope, one of the most zealous botanists of his time ; this valuable collection having been presented to it by his son, the present distinguished Professor of Chemistry in the University of Edinburgh. That proper accommodation will be found for such a botanical treasure, there is no reason to doubt, considering the enlightened views of those gentlemen who are conducting the arrangements for the new garden at Inverleith.

of Corstorphine Hill,—a gentleman who left Edinburgh about half a century ago, and who has been settled in the neighbourhood of the French capital for the last forty years, as an “ingenieur des jardins Anglois.”

The exit from Paris in this direction is truly superb ; particularly the Champs Elysées and grand avenue leading from the Place Louis Quinze to the triumphal arch on the rising ground at the barrier of Neuilly. This elegant building was destined to commemorate the remarkable successes of the French arms which terminated in the Peace of Presburg. It was only in progress when Buonaparte lost the throne, and it will probably remain unfinished ; but enough has been done to shew the taste of the architect, and to produce landscape effect. We passed the Seine by the Bridge of Neuilly, one of the finest in France. It was designed by the architect Perronnet, and consists of five large and equal arches. Although forty-five years have elapsed since its erection, it has still a new appearance. Immediately afterwards vineyards began to occupy the declivities on both sides of the road. The lowest parts of the ground are very generally laid out as kitchen-gardens, for the supply of Paris. They are only very slightly enclosed, and frequently without any sort of fences. The prevailing crops seem to be pease, haricots, and asparagus. The *Nanterre pea*, which originated in this neighbourhood, is, we may remark, accounted the earliest and best that comes to the Marché aux Herbes, in the first part of the season ; and it may be worth while to procure for the Society a package of the seed from the shop of Vilmorin-Andrieux. Some fine villas afterwards presented themselves, distinguished generally by rows and clumps of Robinia, the beautiful foliage of which delighted us. We had a good general view of Malmaison, the

seat of the late Empress Josephine, and once the chosen retreat of Buonaparte; and also of Lusienne, the villa of Madame du Barry, the favourite of Louis XV. The great Machine of Marly, constructed by Rennequin, could not fail to arrest our attention for a time: at one place, we passed below the rods which move the pistons. It is now comparatively in disrepair: when perfect, it was calculated to raise daily 5000 tons of water to the height of 500 feet.

Hennemont.

Having breakfasted at St Germain, we walked to Hennemont, where we found Mr Blaikie at the house of Mr Hudson, an Englishman, who had been principal gardener to Josephine at La Malmaison, but had left the place upon her death, and retired to this pleasant spot, which he has purchased, and now occupies as a *metairie*, or possession chiefly laid out for profit, but partly for pleasure. Hennemont, with extensive vineyards around, formerly belonged to a brotherhood of friars, who were dispossessed in the early period of the revolution, when their grounds were sold in lots, as national property. Some monumental stones, with the original inscriptions nowise obliterated, now form steps at the garden-door; so that there seems to exist no dread of such property ever being reclaimed or challenged by the churchmen; and from what we have already observed of the feelings of the people, this confidence is perfectly well founded. The house stands on the top of a hillock, from which little vineyards slope on every hand. It commands a rich and varied prospect, including Mont Valerien, and terminated on two sides by the great Forest of Laye. This forest makes an extensive sweep around the town and palace of St Germain; and deer and wild boars, we were told, still abound in it. Mr Blaikie men-

tioned, that, last Sunday (being, we believe, the fête of the Exaltation of the Cross) Mount Valerien had been crowded with people from morning to night; that many processions of priests, bearing crucifixes and banners, had come from Paris to it; and that probably not fewer than ten thousand pilgrims, or rather idle Parisians, had accompanied these processions to this emblematical Mount Calvary.

Mr Hudson's vineyards are better managed than any we have hitherto seen, indicating the hand of a judicious vigneron, and affording an example of the mode usually followed by the superior cultivators, such as those at Argenteuil. The plants are in general about three feet and a half high. The stems are, in most cases, laid down, or bent at the base and covered with earth: although, therefore, each stool is two feet apart, it thus happens that the stems from the separate stools approach nearer than that to each other. They are tied to small stakes (*echalas*), frequently two, three, or even four shoots to each stake. The trimmings resulting from the second dressing (*esourselage*), are collected in little bundles, and were now stuck about the tops of the vines and props. In this way they afford some degree of shelter to the bunches of fruit below, without excluding the sun: they are thus at the same time dried or *wijn*; for the cuttings both of the first and second dressing are, very economically, preserved for winter-fodder to cattle. During winter, the vines are cut very low, commonly within a foot of the ground. The *gamet noir*, which resembles our small black cluster,—the *meunier* or dusty miller,—and the green *chasselas*, are some of the principal kinds here cultivated.

We spent some time in the house, enjoying the lively conversation of the venerable Scoto-Gallican gardener Blaikie. He told us, that, in 1775, he was sent by Drs Fothergill and Pitcairn of London, two of the most distin-

guished botanical cultivators of their day, to the mountains of Switzerland, in search of rare alpine plants; and that it was he who sent home all those Swiss rarities marked in the Kew Catalogue as communicated by those eminent physicians. Dr Fothergill for many years maintained a rich botanic garden at his seat at Upton in Essex; and in this garden, we may remark, one of the Society's deputation (Mr Hay) spent a year, in the early part of his career as a gardener. Dr Pitcairn had also a valuable collection in his garden near London. In the course of 1776, Mr Blaikie formed the plan of following his profession in France*; and his first employment was the laying out of an extensive garden for Count Lauriguy, at Mont Canissée, between Harfleur and Havre-de-Grace. In 1778 he settled near Paris. At this period there was no nursery about Paris, from whence select ornamental trees or shrubs could be got. The forming a collection of these was then a business of great difficulty and labour. At Vitry, fruit-trees of pretty good quality were to be procured; also avenue-trees, or *arbres d'alignement*, such as elms, limes, and horse-chesnuts; but none of the rarer evergreens were to be purchased. In the following year, 1779, he was employed in forming the princely villa of Bagatelle for the Comte d'Artois. M. Bellanger, a French artist, managed the arrangement of the parterres and shrubberies immediately around the house, and finished them completely in the French style, with abundance of architectural ornaments. Mr Blaikie was intrusted with the formation of the more extended

* In the Quarterly Review, vol. xxiv. p. 410, Blaikie is said to have been sent by the Earl of Egremont to the Duke of Orleans, to cultivate pine-apples for him; but this statement must be founded on some mistake. Houtson, an Englishman, had for some years the charge of the Duke's pinery, and may probably be the individual referred to.

pleasure-grounds, which were intended to be in the English style; and in prosecution of his plans, he took in a part of the Bois de Boulogne. The French were, at this time, quite careless about the state of their garden-walks. Mr Blaikie had those of Bagatelle properly constructed with gravel; but the gardeners obstinately declined the labour of cleaning and rolling them enjoined by the English planner, and suffered them continually to become covered with weeds and worm-casts. Ten years afterwards, when Bagatelle was nearly in its glory, the course of events caused it suddenly to change its master; and it then became the favourite seat of revolutionary fêtes. After the lapse of five-and-twenty years more, it has reverted to its original owner; and notwithstanding the dilapidations it had unavoidably suffered, it is still a beautiful place. In 1784, Mr Blaikie was employed at Mouceaux, the seat of the Duke of Orleans near Paris, particularly in constructing splendid hot-houses in the garden; but these were much injured in the progress of the revolution. He afterwards planned St Leu at Taverny, in the Valley of Montmorency, for the same nobleman,—a place still in pretty good repair. And in 1786, he laid out Raincy, in the Forest of Bondy, for the same extravagant personage. This place was greatly destroyed during the revolutionary times; it is now the property of M. Livry. The Duke, it is well known, by his expensive magnificence, squandered his vast fortune, and, in order to retrieve it, formed the strange resolution of converting his town residence, the Palais Royal, into shops, cafés, gaming-houses, &c. A considerable debt still remains due to Mr Blaikie by the Orleans Family; and he has a claim of reparation on the French Government, for a robbery having been committed on his house during the revolutionary period, when the

laws were set at defiance. The liquidation of these claims alone detains him in France, it being his earnest wish to revisit his native country, after so long an absence. Mr Hay presented him with a plan of Edinburgh, including the recent additions and improvements; and Mr Blaikie felt much interest in tracing the astonishing progress of the Caledonian capital*.

* We have been the more anxious to particularise some of the principal gardens and places, in the laying out of which Mr Blaikie has been engaged, because, as far as our reading goes, we have not observed that sufficient justice is done to him by French authors who take occasion to mention the state of gardening. For example, Mr Dulaure, in his well known and popular "Description des Environs de Paris," in treating of the seats above mentioned, omits all notice of Mr Blaikie's name. When describing Bagatelle, after giving due praise to M. Bellanger, he speaks of the jardin Anglois with high approbation: "Sa composition est très ingénieuse; ce n'est point cette froide et majestueuse symétrie, ces perpétuelles alignemens qui ne produisent qu'une stérile admiration; c'est la tableau d'une nature agreste, riante, et embellie par la main de talens." This is indeed a just eulogy on the labours of Blaikie at Bagatelle; but, his name not being once mentioned, the reader would naturally conclude the whole to be the work of Bellanger.—Again, the whole praise of Mousseaux is given to M. Carmontel; but this place was most essentially indebted to Mr Blaikie, and, in particular, he planned and executed the hot-houses. "La serre de ce jardin," we are told, "a la réputation d'être une des plus belles que l'on connoisse;" yet Blaikie's name is suppressed.—As to Raincy, we are informed, that the garden "est dessiné avec beaucoup d'intelligence, dans le genre du jardin Anglois;" but the merit is wholly ascribed to "M. Pottier, chevalier de l'ordre royal et militaire de St Louis."

It may be right to add, that we take notice of these things without the slightest communication with Mr Blaikie. Our countryman has spent his days as a practical designer of gardens; he never published any thing; and, from what we know of his character, we may add, never wasted a thought about his own fame as a garden-architect. In France the number of writers on horticulture and gardening is great; but the writings themselves prove, in many cases, that the authors are rather theoretical than practical gardeners; and we believe we may safely say, that, in that country, notwithstanding the number of books, there are comparatively few practical

Palace of St Germain.

Along with Mr Blaikie we proceeded to view the Palace of St Germain, reared by Henri Quatre, and rendered peculiarly interesting to Scotsmen, by having been the place of refuge of the exiled Royal Stuarts. The situation is commanding, and the prospect from the windows and from the terrace near the palace, rich, varied, and extensive, embracing the meanderings of the Seine, much of the Forest, and closed in the distance to the eastward by the towers of St Denis. We were shewn the apartment in which Louis XIV. was born, and that in which James VII. breathed his last. During the reign of Buonaparte, it was employed as a military school; at present it is wholly unoccupied. Workmen were now engaged in obliterating the N's which had every where been sculptured in honour of the name Napoleon; and it is understood to be the intention of the present government to keep the palace in repair*.

In descending to the banks of the Seine, we passed over the site of the ancient chateau of St Germain, and could trace some of the foundations of grottoes, crypts, or temples, which had once ornamented its terrassed gardens. On this bank we met with some plants, which are rather rare in England, and not met with in Scotland; such as, *Lactuca Scariola*, *Stachys germanica*, *Antirrhinum Elati-*

gardeners capable of giving designs for gardens, and also of undertaking the execution of the designs. The practical gardeners are in general little better than mere labourers. There are indeed some distinguished exceptions, particularly in the family of the Thouins.

* This has not been very effectually done. On occasion of a subsequent visit to St Germain in August 1821, I found the parapet-wall of the principal entrance overgrown with *Prenanthes muralis*; and I am certain that no such large plant existed there in 1817.—N.

ne, repens and minus, *Conyza squarrosa*, *Erigeron canadense* *, and also with several which are not British natives; particularly *Carthamus lanatus*, commonly called *le chardon beni des Parisiens*; *Dianthus Carthusianorum*, *Bupleurum falcatum*, and *Farsetia incana*. In pursuing our walk along the banks of the river, we picked up *Inula hirta*, *pulicaria*, and the large-flowered species, *I. Britannica*; *Chondrilla juncea*, *Salvia pratensis*, *Herniaria hirsuta* and *glabra*, *Bupleurum tenuissimum*, *Sedum cepæa*, *Sisymbrium supinum*;—so that our botanic boxes soon overflowed.

In the course of our excursion we came to a garden, where vines were planted on the north side of the wall, and trained through holes to the south aspect. They were chiefly the *Chasselas*, and *Madeleine*: the bunches of the last-named were now nearly ripe. Having noticed some trees of the *Pêche de Nancy*, or *Apricot-Peach*, Mr Blaikie praised the good qualities of the fruit. It has the figure of a peach; but possesses distinctly the flavour of an apricot, considerably resembling that of the *Moorpark*. A late-flowering walnut, called *Noyau de St Jean*, may deserve the attention of the Society. Mr Blaikie mentioned, that it does not flower till near the middle of June, and yet produces its fruit about the same time with the varieties which blossom more early. This seems a quality peculiarly desirable in our Scottish climate. Plants of this variety may be procured at the garden of *Vilmorin-Andrieux* at Paris,—or from the nurseries at the *Luxem-*

* This has already been noticed, p. 209. Mr Blaikie remarked, that it was brought from Canada and cultivated at Kew near sixty years ago. It seems now to have spread over the whole of the north of Europe; for our friend met with it even among the Alps.

bourg under the direction of Mr Hervy. In the course of conversation, Mr Blaikie recommended to us the pear called the *Sylvange*, originally brought from Metz in Lorraine. It is a late pear, about the size of the swan-egg, and tastes like a beurré. He mentioned with approbation, too, the *Chaumanette*, also a late pear, which he thinks likewise originated at Metz.

We pursued our walk towards the Forest of Laye, into which we were desirous of taking a short ramble. Having, on our way, noticed the mistletoe on forest-trees, Mr Blaikie mentioned that it here grows on the Virginian poplar, the mountain-ash, the lime, and several other kinds. The berries on some mountain-ashes by the road-side seemed larger than usual: and we were told, that when the roan-tree (*Pyrus aucuparia*) is grafted on the service-tree (*P. domestica*), as is frequently done, the fruit not only becomes larger, but is produced in greater abundance. Such young grafted trees also come more speedily into a bearing state. On farther examination, we ascertained that many of the roan-trees, the fruit of which attracted our particular notice, were really of a distinct species, *P. Americana*. Service-trees or *cormiers* are here very commonly cultivated as fruit-trees; some of them were of considerable size, the trunk of one tree measuring more than eight feet in circumference. The fruit is chiefly used in the manufacture of cider, for communicating acidity to the apple juice.

Chesnut-trees appeared, both scattered up and down as single trees, and in small separate plantations. They were frequently of great age and of large dimensions; the bole sometimes measuring 13, 14 or 15 feet in circumference. Some of them would have afforded admirable studies for painters of trees. One huge trunk, though only about 12 feet high, has a very remarkable

appearance: it is wholly deprived of its bark on one side, and a large hole passes through and through; a stripe of bark, however, remains fresh on the other side, and conveys support to a handsome and vigorous head. Another great tree appears to have been recently cut over about the same height; and we learned, that the proprietors are in the practice of heading down such old chesnut-trees, with the view of renovating the bearing wood, and improving the fruit. Although those now spoken of are *chataigniers* or common chesnut-trees, and not *marronniers*, or of the large-fruited variety, their nuts meet with a ready sale at Paris.

Many very small or narrow vineyards here presented themselves; and all of these, we were told, are probably separate properties. The *gavelkind* succession, or equal division of territorial property among heirs, introduced by the revolution, has already produced some strange anomalies in this district; one person having sometimes succeeded to different small stripes of ground, at the distance of a mile or more from each other. The division takes place in ridges and half-ridges, varying in breadth according to the size of the property to be divided; and it has sometimes happened that an heir who succeeded only to a half ridge, might be able to hop across his estate. If part of the land be of good quality, and part of inferior quality, each heir has assigned to him a rateable proportion of each. The country, in populous districts, has thus acquired a sort of patchwork aspect; small plantations of vines being flanked by tiny fields of corn, or of some kind of green crop. The natural jealousy of the heirs very generally prevents a concert among themselves, which, one would think, might be beneficial to all parties; for the cultivation of detached stripes of ground must be attended with great additional

labour and trouble. We must, however, admit, that, so far as our observation went, even the smallest properties were well cultivated; but we were assured, that the minute subdivision is already felt as an evil: and whether it will eventually work out its own remedy, seems problematical.

The *vineyards* are here wholly uninclosed; but Mr Blaikie informed us, that the gens d'armes are employed and paid by each parish, for keeping guard during the grape-season. The decisions of the parish-officers against transgressors are held as final, being limited to a slight fine proportioned to the damage. The vintage of a township is made all in one day, generally early in October; and the vintagers are summoned to the field by tuck of drum. In this way people see that they are not wronged by their next neighbours at the gathering of the bunches.

The wine made in this neighbourhood, and all around Paris, is in general of inferior quality, compared with that of more favoured districts of France. It is used chiefly by the growers themselves, or is consumed in the lower class of taverns. The best is produced from the extensive vineyards of *Argenteuil*, which supply many of the *ginguettes* and *bastringues*, or drinking-houses and dancing-houses in the neighbourhood of the capital, as well as some of the Parisian restaurateurs who advertise cheap dinners. At *Argenteuil* the *vignerons* pay the utmost attention to their plantations, and they have greatly improved in character, in Mr Blaikie's remembrance; he regards, indeed, their mode of cultivation as approaching to the perfection of the art, as far at least as productiveness is concerned. They apply manure very freely; but this practice, though it swells their *recolte*, is thought to deteriorate the quality of the grapes. Mr Blaikie mentioned one kind of manure which is much used, and from which we certainly would

not predicate any improvement in the flavour of the fruit. It is called

Poudrette,

and is neither more nor less than night-soil dried, and reduced to a powder. Poudrette, we understand, was first recommended by the celebrated Parmentier, about thirty years ago, as a top-dressing for various field-crops. There are now regular manufactures of it, especially at La Chapelle, near St Denis. Mr Blaikie considers its fertilizing properties as remarkably great. It is now a good deal used in kitchen-gardens, especially where vegetables are raised for the Paris market, and where of course the ground is constantly heavily cropped with peas, onions, haricots, &c. Sometimes it is mixed with light earth, and scattered over the surface of the ground. Frequently it is formed into a compost with the weeds and refuse of the garden, and some marly loam or light mould; the poudrette being spread on the compost-bed, in the proportion of half an inch to six inches of weeds and earth. Such compost is considered as well adapted for stimulating the roots of fruit-trees, especially cherries, figs and vines. We may remark, that solid poudrette (if the name be allowable) is now prepared at London, under the title of "Clark's desiccated compost," and sold in cakes at 78. Goswell Street. The offensive smell is, to a considerable degree, removed by the addition of quicklime. The cakes are of course broken small before being applied. The poudrette of Paris is kept in sacks.

Succory.

In passing some small fields of succory, Mr Blaikie mentioned, that he regarded the large-leaved succory as merely a variety of *Cichorium Intybus*, improved by cul-

tivation. Although this plant is neglected by us in Scotland, it is here found extremely useful. The young leaves are used in salads, and for this purpose successive sowings are made in gardens. When the plant is raised in fields, the outer-leaves are plucked at successive periods of the summer and autumn, and given to milch-cows (as already noticed, p. 87.) Cows fed on them are said to yield generally about a third more milk than when on ordinary fodder; but at first, we understand, the milk acquires somewhat of a bitterish taste. This kind of green food is also accounted excellent for promoting the production of butter. At the approach of winter, the roots of the succory-plants are dug up and stored in a cellar or out-house. They are laid horizontally on a bed composed of sand or light soil, with the crowns or heads outermost and uncovered; a thin layer of soil is then added; then another row of roots; and this is repeated till the bed be perhaps three or four feet high. It is only necessary that the place in which the roots are thus stored, be defended from frost; light is not only unnecessary, but would be prejudicial. Here they afford the blanched shoots called *Barbe-de-Capucin*, much relished as a winter sallad. Sometimes, our friend told us, the roots are packed among moist sand in a barrel, having numerous round holes pierced in its sides: the crowns of the succory plants are so placed, that the shoots may readily push their way through the holes: they are thus kept quite clean, are very easily gathered as wanted, and repeated cuttings are obtained. When sent to market, the roots are generally drawn from the beds, and tied in bunches, with the etiolated shoots attached to them.

On banks by the ditch sides near the Forest, the annual turnsole, *Heliotropium Europæum*, was growing pretty

abundantly, along with *Pennisetum viride*; and on the sandy downs, *Statice cephalotes* β (*S. plantaginea*, Decand.), and *Veronica spicata* appeared. We could see very little of the Forest itself, as we found it necessary to keep the beaten tracks, in order to ensure our timeous return to St Germain, and thence to the capital in the evening. The trees, in the small portion of the Forest visited by us, were chiefly elm, beech, ash, poplar, wild cherry, with a few limes and oaks. Some of the trees are tall, but very few are of large dimensions, or bear marks of considerable age. *Thymus Calaminta* grows plentifully among the brushwood. *Globularia vulgaris* may be noticed as a rare native; and Mr Blaikie mentioned his having found a variety of this plant, with white flowers. *Actea spicata* is likewise a native of the forest.

Sept. 20.—To-day we waited on the Compte d'Escars at the Tuileries. We entered at the Place de Carrousel, and were much pleased with the triumphal arch, although no longer crowned by the Venetian Horses. We found the Count in his apartments: He instantly recognised Mr Macdonald, and spoke of the happy days he had spent at Dalkeith Park, when in the suite of the Compte d'Artois, at Holyroodhouse. The view from the windows in the upper part of the Palace, commanding the garden and the Elysian Fields, gratified us much; and as the letters of permission to visit the public gardens were not yet ready, but in progress, we resolved, without waiting for them, to take the present opportunity of viewing those of the Tuileries. We were, indeed, perfectly aware that these, and even the other gardens, are liberally opened to foreigners; but an application having been made, we naturally felt

A a

some delicacy in entering any of them before receiving an answer.

We saw little of the Palace itself, and felt little curiosity to view it. We only remarked, that the balcony in front of the gallery along which the King daily passes in going to mass, is adorned with numerous marble vases, having pots with geraniums in flower concealed in them. The plants are chiefly varieties of *Pelargonium zonale*, *hybridum* and *inquinans*.

Tuileries Gardens.

The gardens of the Tuileries, it is well known, remain nearly in the style of Le Nôtre, who planned and executed them, and who thus laid the foundation for that lasting fame, which was secured by his works at Versailles. The coup d'œil is highly pleasing; and we are bound to add, that we were offended much less by stiffness and formality than we had been taught to expect. Under the windows of a palace, and almost in contact with the streets of a great city, symmetry and neatness seem more appropriate than attempts at the imitation of natural scenery. The grounds exceed 60 acres in extent, almost forming a parallelogram. Along the front of the palace runs a broad terrace, raised by only three steps above the general level of the ground; and at right angles to this, on either side, are other terraces, extending the whole length of the garden. A spacious main walk or drive conducts straight through the centre, interrupted only by two pieces of water; first by a circular pond near the chateau, and afterwards by a very large one, of an octagonal form, near the gate leading to the Place Louis XV. It is scarcely necessary to say, that there are several subordinate walks parallel to the main one, and also numerous cross and diagonal paths, the

vistas of which generally present some statuary ornament. All the walks are laid with white sand, and very carefully kept;—not even a speck of the annual posy to be seen. Next to the Tuileries, two embroidered parterres partly modernised, each having a pond and jet-d'eau in the centre, form the principal ornaments. Towards the middle of the garden a profusion of trees, both planted in rows, and forming thickets or groves, characterise the scene. Most of these are young trees, or apparently not more than thirty or forty years old; but on the far side of the garden, some fine specimens of Le Nôtre's originals remain; and these, viewed from the Palace terrace, happily blend with the extensive mass of foliage in the Champs-Élysées. The surface of the garden is evidently unequal; but the inequality has been well disguised. The large octagonal pond and grand entrance from Place Louis XV. appeared to us to evince the genius of Le Nôtre more than any other part. On each side of this entrance a semicircular glacis or *rampe* sweeps smoothly up to the two lateral terraces. The space thus created on either hand affords a liberal area within the gate, the whole having the appearance of a rich amphitheatre, with groups of statues most judiciously placed for producing effect. The air at this place is considerably cooled by passing over the extensive piece of water, and by means of the constant sprinkling of a lofty jet. Meantime the Royal Chateau is only obscurely seen through a long vista of trees.

The terraces, likewise, are highly creditable to the artist. The *Terrasse des Feuillans*, next to the Rue Rivoli, and separated from it by a magnificent iron-rail, richly gilt at the top, was at this time lined with large orange-trees, in boxes. The collection of these, we may notice, is very extensive; and although such specimens are stiff in themselves, yet in this

garden they are disposed with so much taste, and so well interspersed with oleanders, double-flowered myrtles, and sweet bays, that upon the whole they produce a very pleasing appearance. These orange-trees were kept at St Cloud during the domination of Buonaparte, and were brought thither by orders of the present King. We were rather disappointed at being told, that the orange-flowers, even in this royal garden, and under the nose of his Most Christian Majesty, are farmed to confectioners and perfumers, whose servants have step-ladders at hand, for gathering them as they appear, and who pay a sum equal to about L. 200 a-year for the privilege! The other long terrace walk, next to the Quai de Tuileries, and commanding a view of the Seine, is equally worthy of admiration. The natural slope of the ground renders its elevation more prominent; but all its proportions, as well as its decorations, both architectural and arboreous, are well managed. We are told that it was the favourite promenade of Buonaparte, and of Marie-Louise and her son; but the present royal family seldom use it: indeed, when we walked along, there was not a Frenchman upon it, although many hundreds were strolling through the lower walks, or lolling on reed-chairs reading the gazettes.

The flowers in the borders are few in number, considered as botanical species, but they are planted in copious profusion: they are all of the gaudy order, being intended merely for show. The object, and we presume to think the legitimate object here, is to keep the parterres always gairish with brilliant blossoms of different colours. The flowers of May, June, and July were now supplanted by those of the autumn months; particularly, asters of many hues, French marigolds, balsams, zinnias, marvel of Peru, and the double-flowered *Helianthus multiflorus*. Many

hundreds of specimens of *Pelargonium inquinans* and *zonale* are yearly planted in these borders, and add considerably to their ornament. We may remark, that the "labyrinth of cypress, and hedges of pomegranate," mentioned by Evelyn in his *Memoirs*, have disappeared; but a *boulingrin*, in no very favourable plight, and the traces of a rustic theatre, still remain. The grass-turf is regularly watered, and was now of a lively green; but it does not form nearly so compact a sward as we are accustomed to see in Scotland. In dry weather, all the principal flower-borders are likewise daily watered, by means of long flexible tubes, in the manner described when speaking of the flower-plots in the court of the Palais Royal, (p. 345.)

Notwithstanding the immediate proximity of a vast city, all the trees, shrubs, and plants in this garden, even those of delicate foliage, appeared healthy and with unimpaired verdure. The atmosphere is here incomparably more pure than in the vicinity of London, where the smoke from innumerable coal-fires, very generally rests over the city like a cloud. In Paris there are comparatively few fire-places, and in them wood and charcoal are chiefly used. Many families have almost no cooking in their own houses during the summer months, the whole family dining at a restaurateur's.

During the republican period, when "Liberté, égalité," was the cry of the day, the parterres of the Tuileries were planted with potatoes, and our countryman Blaikie was actually called upon to furnish the seed-stock or tubers, and direct the planting. To this happy expedient (suggested, it is understood, by some of the sçavans of Paris) of converting these pleasure-grounds for a time to a purpose which seemed useful and national in the eyes of the citizens, the safety of the whole may be ascribed. At pre-

sent they are certainly much more useful to the populace of Paris than to his Majesty; but the King is the Father of his People, and his children of all ranks think they have a right to romp about in his garden. They do so in the most innocent style imaginable. Those who know how liable every public walk around Edinburgh is to all sorts of dilapidation and destruction that the youthful mind can invent, or that mischievous hands can perpetrate, will readily excuse our expressing some surprise at seeing ill-dressed lads and ragged boys brushing freely along among pieces of beautiful sculpture and rare exotics. But although *tout le monde* passes to and fro through this garden, no injury, we are assured, is ever done to the fine plants or to the invaluable groups of statues. Nor is this to be ascribed wholly or even principally to the vigilance of the military guards. The Parisian children seem to be trained up with a reverential awe of doing injury to any public work or promenade. The most tatterdemalion-looking youths may be seen staring at the flowers and the statues, but they never touch: they would even rebel against any one who should presume to do so. This trait of character certainly forms a striking contrast to what occurs at our Modern Athens; and to the superior education of youth which we justly boast, due care to produce this salutary impression on the tender mind, remains to be added.

On leaving the palace garden, we passed along the Quays of the Tuileries and the Louvre. Here the officers of the customs (or tide-waiters, as we would call them) have ornamented their wooden-huts, by forming them into little harbours, covered with *Cobbea scandens*, intermixed with the scarlet-bean and nasturtium.

Flower-Market.

We proceeded, by the Pont au Change, to the Quai Desaix, to view the celebrated *Marché aux Fleurs*, Saturday being the principal day of resort to it. At a more early period of the season, we were told, when the flowers of spring and summer were in their prime, we would have seen it to much greater advantage; but, as it was, we felt highly gratified. The market is bordered with rows of low-growing trees; and it is furnished with two fountains, which afford an abundant supply of water for refreshing the plants. Great numbers of select shrubs and herbaceous plants in flower, were, at this time, exposed for sale; the shrubs chiefly in small square wooden boxes, painted green, and the herbaceous plants in common flower-pots. Among the shrubs we remarked *Jasminum grandiflorum* and *azoricum*; rosemary; *Daphne odora*; oleanders, both single and double; small orange-trees; hydrangea, or hortensia, as it is here commonly called; and many fine specimens of double-flowered pomegranate, dwarfed in a remarkable manner, and now covered with their rich orange-coloured blossoms. *Rosa multiflora* is common in pots, and seems to flower freely in this situation. Flowering plants of the splendid *Datura arborea* may be added to the list. The flowering of this plant, Sir James Edward Smith, in his *Tour on the Continent 1790*, mentions as a rare occurrence; but it has now become common at Paris, and besides adorning the peristyle of a palace, it may sometimes be seen languishing on the window-sill of a citizen; to whom its great tubular blossom has suggested the emphatic name of *trompette de jugement*. Being a native of Peru, it was formerly kept in the hot-house; but it has proved as hardy as the *Tropæolum* of the same

country, and is found to thrive best in the cool greenhouse, or in a frame, where it is merely protected from the frost. Among the herbaceous plants were double tuberoses; double dahlias, buff-coloured, pale and dark purple; many pots of *Amaryllis lutea*, held almost sacred as the Lily of Palestine, of which our Saviour said, "Consider the lilies as they grow," &c.; and also several pots of *Phlomis Leonurus*, in brilliant flower. An excellent rule seems to be generally followed by the gardeners,—that of affixing the botanical names to the plants offered for sale. On one stall was a quantity of the tubers of the Spanish Batatas (*Convolvulus batatas*). The cultivation of this tuberous-rooted plant in the open ground at Paris, as an article of food, has of late years been strongly recommended by Mr Lelieur, in a memoir on the subject: he at the same time shews its practicability, by yearly producing them in this way at St Cloud. Their culture cannot, however, have become general, else the tubers would have been sent to the *Marché aux Herbes* rather than to the flower-market. We had the curiosity to purchase a few of these *patates douces*; and the seller mentioned, that the plants had been forwarded in a hot-bed frame, and planted out in May; adding, that the *pistache de terre* (*Arachis hypogæa*) answers in the same way. Pots of Indian-cress, and of sweet herbs, particularly basil, were common; others filled with long verdant grass "pour les chiens," formed rather an amusing article of merchandise. In the early part of the day, we learned, great numbers of the Parisian ladies frequent this market: at this time there was little company.

The few inquiries which we had an opportunity of making, satisfied us, that orange-plants, double-flowered pomegranates, oleanders, tuberoses, and dahlias, may here

be purchased cheaper than at London; but that camellias and other plants of China, New Holland plants, and Cape heaths, may be procured much better and cheaper in the nursery-gardens around the English capital.

At Paris fashion regulates every thing, exerting its dominion over the productions even of the *Marché aux Fleurs*. Every year some particular kind of flower comes into fashion, and is bought up with avidity, frequently at high prices. It is the business of the cultivators to mark those caprices, and to gratify them. The demand naturally increases the production of the favourite plant, all the cultivators directing their attention to its propagation. The market is glutted, the price falls, the flower is sported by the *bourgeoisie*, and it forthwith goes out of fashion. A very few retain their popularity; such as the *pervenche* (periwinkle or *Vinca major*), the favourite of Rousseau; the *capucine* or Indian-cress, frequently with large double flowers; the Neapolitan violet, or var. *pallido-plena* of V. odorata; the sweet heliotrope, and the *mignonette*.

The view of the *Marché aux Fleurs* could not fail to recall to our minds the total want of such a market at Edinburgh. Our northern capital has, within the last thirty or forty years, so vastly increased in size and in luxury, that such an establishment seems now to be called for. Sales of greenhouse plants sometimes take place in what are called the *Agency-Offices*, and pots of wall-flower, &c. are frequently hawked through the streets in wheelbarrows. The Edinburgh flower-market might conveniently be joined with a *fruit-market*, which is also a desideratum, and one of still greater importance. Some years ago, indeed, the Horticultural Society appointed a committee to confer with the Lord Provost and Magistrates of the city on the institution of a "*Fruit and Flower Market*;" and we trust that this import-

ant object will not be lost sight of. Were such a market established in a convenient and central situation, (such, for example, as the margin of the sloping and winding terrace-road leading from Prince's Street to the Little Mound, recommended, we believe, by the Committee); a greater quantity of fine fruit would be brought to Edinburgh for sale, and many showy and fragrant plants would be rendered accessible to the inhabitants. The taste for fine plants is evidently on the increase at Edinburgh. Besides the collections of these to be found in the long-established nurseries of Leith Walk, Broughton, Meadowbank and others, we have, within these few years, seen rich sale-collections arise at Comely Bank beyond Stockbridge, and at Stanwell Lodge near Leith. It seems clear, therefore, that in establishing a fruit and flower market, the Magistrates would at once consult the comforts of the inhabitants, and promote the welfare of many deserving cultivators in the neighbourhood of the city.

Bird-Market.

In returning homewards, our attention was attracted by the Bird-Market, on a quay near the Pont Neuf. Live quails were plentiful, and several of the passerine tribe which abound in France. At an earlier period of the season, we understand, golden orioles, hoopoes, rollers, and all birds of splendid plumage, are brought to this market in great numbers; and in May and June the nests and young are often exposed to sale. Those now mentioned are rare birds in Britain, being little more than occasional visitants of our island: in France they are resident, and found in great plenty. Numbers of the more common singing-birds are always to be procured in this market; but the rarer birds of song, and the parrot-tribe, are sold chief-

ly by dealers on the Boulevards of St Martin and the Temple.

The Oratoire.

Sept. 21.—This being Sunday, we attended the Protestant Church of the Oratoire, in Rue St Honoré, at the usual morning hour, and were, at first, not a little surprised to find the service going on in English, and the congregation composed almost exclusively of British natives. After hearing a sermon by the Reverend Edward Forster, A. M. (chaplain, we believe, to Sir Charles Stewart), we remained in church, being informed that the French service would commence at mid-day. During the interval we read some of the *affiches* on the interior walls of the church; among others, one from Mr Forster, expressing his wish that the English congregation should join in the psalmody. The French Protestants do so, and it is believed had been rather scandalised at the silence of the English worshippers.—In a short time the Parisian congregation began to assemble. A female vestry-keeper placed a Bible on the pulpit-cushion. The clerk, from his own desk, read a lesson from the Gospel by St John, and gave out a psalm. Dr Marron having entered the pulpit, read prayers from a manuscript book, and then preached a sermon, with considerable fluency and eloquence. The congregation was by no means large, and several pews remained wholly unoccupied. There is only another French Protestant church in Paris, that of the Visitation, in Rue St Antoine; the Panthemont, in Rue de Grenelle, on the other side of the Seine, having some years ago been converted into a magazine. If there be, as is said, about 40,000 Protestants in the capital, it seems but

too certain that not more than a fortieth part of them frequent the church.

In returning to our lodgings, we found the market of the Innocents rather crowded ; but fruit and nosegays were almost the only articles now selling.

Halle au Blé.

The great flour-market, or Halle au Blé, was also open. This is a vast covered rotunda, about 150 feet in diameter, and lighted from the roof. Before the establishment of this depot, a sudden and accidental scarcity of flour often produced alarm and consternation throughout Paris, without the slightest foundation. Here a great store is always kept, not only of wheat, but of flour ready for the bakers. Bread, we may remark, is comparatively little used in Holland ; in Flanders the consumption is nearly equal, in proportion, to that of England ; in France it is certainly much greater. " Du pain " is one of the most frequent demands to be heard at the table-d'hôte or the restaurateur's. The Halle was accidentally burnt down in 1802 : the new one has been greatly improved, timber being now altogether excluded from the structure, and the roof formed of cast-iron arches and plates of sheet-copper.

Tivoli Gardens.

In the afternoon we took a walk along the Rue de Chaussée d'Antin, which has been raised to celebrity by the Paris Spectator. In the Rue St Lazare we noticed the gate of the Tivoli Gardens, of which we had often heard the praises ; and we took this opportunity of viewing them. The price of admission (between three and four francs) seemed high ; but we afterwards learned that this was to be a gala night, and though no company had yet

arrived, we saw preparations making for illuminations, and for a display of fire-works. This place formed the villa and garden of M. Boutin, treasurer of the navy before the Revolution. The grounds had evidently been laid out with taste and at great expence; terraces having been formed, and some rising ground behind having been reduced to regular slopes. The grounds are pretty extensive, including perhaps ten or twelve acres within the walls. They have inevitably suffered injury from the use to which they are applied; and, when thus viewed in the day time, are certainly nowise superior to Vauxhall Gardens at London. A few fine trees still remain; and a piece of water in the lower part of the garden, ornamented with a boat and pendant, have a pretty good effect. On our leaving the gardens, we were offered pass-tickets, and politely pressed by the door-keepers to return, it being held forth as an inducement to us, that dancing would commence in two hours, and that the "tire de feu d'artifice" would to-night be "très superbe!" On our expressing ourselves satisfied with what we had already seen, and making some observations on the trees of the place, it was sagely enough whispered that we were certainly "pepiniéristes Anglois."

The inhabitants, in their holiday dresses, were now beginning to throng the Boulevards des Italiens; and some fellows were showing off legerdemain tricks to crowds of surrounding admirers. But the people were orderly and quiet, and we did not discover one instance of intoxication in the course of a pretty long walk.

In Paris, we may here remark, considerable facility is afforded to strangers in finding their way, by the simple expedient of painting the names of the streets which lead to the Seine, in black; and those which run parallel to it, in red.

Sept. 22.—On our former visit to the Jardin des Plantes we had seen little more than the hot-houses, and the great winter-repository for greenhouse plants, with the exotics belonging to these houses. We wished speedily to avail ourselves of the invitation kindly given to us by Professor Thouin, to examine the whole establishment in detail; and accordingly dedicated the greater part of this day to that purpose.

Having procured a fiacre, we desired to be driven to the site of the famous Bastille, which is on the banks of the Seine, nearly opposite to the main gate of the Garden of Plants.

The Bastille.

This ancient prison had been most effectually razed to the ground in 1789, it being now scarcely possible to trace even its foundations. About one-half of the fossé still remains, however, and is partly covered with water. It was intended by Buonaparte to have had this fossé converted into a canal or dock, connecting with the Seine; but this plan seems now to be abandoned. On another part of the Bastille grounds extensive depots for grain were built by the Emperor. The site of the building itself is now occupied by a vast wooden house, inclosing the model, in plaster of Paris, of a fountain projected by the same astonishing man; and if this ever be executed in marble or even in sandstone, it will certainly form one of the greatest wonders of Paris, and a signal ornament to the square or Place de la Bastille, which is in progress, as well as a fine termination to the Boulevard St Antoine. The fountain is in the shape of a gigantic elephant, with a castle (the cistern) on its back, it being intended that the water should issue from the proboscis. Of its dimensions some idea may be

formed by the reader, when he is told that it was proposed to construct a small winding staircase in the interior of one of the fore-legs. Two or three workmen are still employed in laying the solid platform or pediment; but the work goes on very drowsily,—and what the superstructure may be, is perhaps not yet finally determined. Among the rubbish of the old building, and on the margin of the ditch, the botanist may pick up *Sisymbrium Sophia* and *tenuifolium*, *Delphinium consolida*, *Rumex maritimus*, *Lactuca scariola*, and *Erigeron canadense* *.

Jardin de Plantes.

Passing the Seine by the Bridge of Austerlitz, the noble esplanade in front of the main entrance of the Garden of Plants excited our admiration. On entering, we began a kind of systematical examination of this national garden; and although copious, and doubtless correct descriptions of all parts of the establishment have been given to the world in successive volumes of the first series of the “*Annales du Museum*,” from the pens of Professors Jussieu and Thouin, we shall not scruple to lay before the reader the notes which we took, adding our remarks in the order in which they occurred, although they may thus sometimes appear rather desultory.

The grounds include about 70 acres; and the principal part of the garden being of an oblong shape, two broad and straight gravel-walks lead directly from the Seine gate to the Museum buildings. These walks, as well as the larger

* In order to get access to the site of the Bastille and see the model of the elephant, it is now necessary to make application for an order (which is given freely), at the Bureau for French Monuments, No. 319. Rue St Honoré.

of the cross alleys, are laid with some kind of pounded scorïæ, such as we call *danders*, with a thin coating of sand over the surface. They thus dry very speedily, and may be used almost immediately after rain. The compartments for the plants are all oblong squares; but the stiffness of these is judiciously broken in upon, in two places; towards the middle of the grounds by a square piece of water, having its broad gently sloping banks richly adorned with shrubs of the most varied character; and near the Museum, by a circular pond, surrounded with showy greenhouse plants in tubs and pots.

Next to the Seine gate, on the left, the first compartment consists of a small thicket of early flowering trees and shrubs, intermixed with vernal plants. The cross-walk in front of this little thicket is shaded by rows of the *Ailanthus glandulosa*, here forming trees of considerable size. The ailanthus, we may remark, seems to have become a common ornamental tree at Paris, while in England it is rather neglected. Even here it requires a sheltered situation; but it was now in vigorous foliage, and, we are told, retains its fine pinnated leaves till winter, long after the walnut and the ash have shed theirs.

On the right of the Seine gate there is a larger collection of early-flowering trees, called the *Bosquet du printemps*. It forms a kind of open grove; and in the interstices are presented to the student, in little heaps, distinguished by tallies, specimens of the different well-marked garden soils, such as sand, loam or clay, humus or black earth, bruyere or heath-soil, gravel, chalk, &c.; and likewise of the principal different kinds of manures.

In the central compartments fronting the gate, is a large collection of all the plants generally accounted medicinal. This is not merely a medical arrangement for the advan-

tage of students ; but the plants are in sufficient abundance to afford a supply for private patients who make application, as well as for those in the public hospitals. The use of simples, at least in popular practice, and among the lower orders, seems to be much greater in France than in Britain. The gathering and the cultivating of physic-herbs form country trades ; and the *herboristes* of Paris are a distinct set of dealers, who offer great store of such herbs for sale, in a lane called La Poterie, connected with the markets at the head of Rue St Honoré.

The Ecole d'Agriculture Pratique, established in 1806, occupies a considerable area on the north, next to the specimens of soils and manures, and separated from these by a low wall covered with Judas-tree. In this compartment examples of different horticultural and agricultural operations and works are presented. The English Ha, ha ! appears, having the sloping bank dressed with violets, and wooded by means of elms laid down. Specimens of brise-vents and hedges, constructed in different ways, and composed of various shrubs and trees, are here seen. Some of the plants employed (as the *Tamarix gallica*, *Ptelea trifoliata*, and *Coronilla Emerus*), would by no means answer the purpose in Scotland ; but the Chinese arbor-vitæ, the Swedish juniper, and the red cedar, which here make very neat hedges, might more frequently be used in forming ornamental divisions in our gardens at home. The sea-buckthorn seems almost to vie with the privet in neatness and efficacy as a division hedge. These pattern fences cannot, of course, be seen to advantage at all times ; the natural progress of vegetation soon disarranging them : but when explained by an expert practical teacher, as Professor Thouin most undoubtedly is, the utility of such exemplars must be great. The different modes of training fruit-trees, and the various shapes which they are made to

assume, are likewise exemplified; though it sometimes happens that the specimen tree has outgrown its exact boundaries or form. The *arbores* trees of Holland are here announced to be *en gobbelet* or *en entonnoir*. The *buisson* of the Paris garden is our *dwarf-standard* trained in a bushy form. The late Mr Nicol, we may remark, recommends in his writings, that a kind of small apple-trees called *buzelars* should be planted in borders; we doubt not that some error has crept in, and that he intended to say *buissons*. We had now an opportunity of seeing both *pyramidal* and *quenouille* trees, properly so called: they differ so slightly, that it is little wonder the terms should generally be considered as convertible. The difference consists chiefly in this: those *en pyramide* taper gradually to the top, forming cones; while those *en quenouille* have the uppermost branches of equal length with the undermost, forming cylinders. Sometimes the lower branches are a little shorter than those in the middle of the tree, and then the *quenouille* or *distaff* form is complete. Pyramidal trees may often be seen twenty feet high; genuine *quenouilles*, never half that height. The simple pyramidal form is much more generally adopted than the strictly *quenouille*. When pyramidal trees are so pruned that the horizontal branches form stages above one another, with intervals between each set of branches, they are said to be *en girandole*. It may be right to remind the reader, that the *espalier-tree* of the present generation of French gardeners is equivalent to our *wall-tree*; and that our *espalier* is their *contre-espalier*. This variation in the use of the terms has naturally arisen from the circumstance of garden-walls in France being almost universally furnished with rails or trellises in front, to which the branches of the trees are tied, while in Britain they are attached immediately to the wall itself. We may, however, claim the merit of retaining the *original*

meaning of the term *espalier*, as is evident from its being used in our sense in the earliest French books on gardening. Our *riders*, we may add, are here called *arbres à tige*; and our common standards are *arbres à plein-vent*.

The various kinds of grafting are likewise here exemplified; and besides the usual modes, some curious *greffes* are shewn. But even these it is unnecessary to specify, as Professor Thouin has described the whole in different volumes of the *Annales du Museum*. His papers are models of complete descriptions; if he errs, it is in being too formally minute. One remarkable attempt, called the *Grefse Banks* (in honour of the late President of the Royal Society), may just be noticed. It consists in endeavouring to unite laterally, by grafting into each other, a number of young trees, so as to form one broad but narrow plank or tree. It had been tried on a dozen of the white American ash (*Fraxinus acuminata*, *Pursh*), and on a like number of the *Sophora Japonica*; but though it has succeeded to some extent, it does not appear probable that it will ever be attended with useful results.

A walk lined with catalpa-trees separates the fruit-tree school from a very pleasing and useful compartment, where specimens of all the corns, grasses, culinary vegetables, dye-plants, and other crops usually cultivated in the north of Europe, are assembled. The species are kept most distinct from each other, and seemed to be very accurately named. Over the spikes and panicles of the corns and grasses, bags are tied when the seeds approach to ripeness; so that the heads, when mature, can be cut off whole, while still remaining in the bags. They are thus at once protected from birds, preserved quite distinct, and hindered from shedding their seed on the ground. Three varieties of succory here appeared; the common large-leaved, which is cultivated in gardens; the *chicorée à navet*, or *café-chicorée*, every way

similar to the former except in having larger white fleshy roots; and a variety with variegated leaves. This last, with the "feuilles panachées," was by much the strongest specimen, the flower-stem being about ten feet high.

This garden of Ceres and Chloris is separated from that of Pomona, by a walk shaded with oriental planes. Here a rich collection of all such fruit-trees as can be cultivated in the open air in France, may be studied. With the view of occupying as little room as possible, the pears are chiefly on quince-stocks, and trained to the pyramidal form; the apples on paradise or on doucin stocks. So complete is the establishment, that at one corner is a tool-house, where every implement used in the management of fruit-trees may be seen. This assemblage of fruit-trees, and of their varieties, we found very interesting, and examined minutely, more particularly as nothing of the kind exists in Scotland. A tally, bearing either the name, or a number referring to the garden catalogue, is placed beside each tree. A list of the greater part of the trees will be found in the Appendix, No. VIII. This collection, as well as the other fruit-trees in the Jardin, are under the management of an appropriate curator, M. Dumoutier, who has the reputation of being very expert and intelligent in his department. When we expressed to Mr Thouin our high approbation of this part of the garden, he immediately said, that grafts from any of the kinds of fruit-trees which we might specify, would, in the proper season, be sent to the Caledonian Horticultural Society at Edinburgh. We cordially thanked him, on the part of the Society: but we have to regret, that, owing to the delay in instituting an Experimental Garden, it has not yet been in our power to avail ourselves of the liberal offer of the Professor. The formation of a Pomarium, on a similar plan, ought, in our opinion, to

form a prominent object in the arrangement of the Society's garden, when it comes to be established.

We now gave our attention to the central compartments, beginning with the oblong square basin, and returning back towards the Seine gate. The pond contains many rare *aquatics*; and the four sloping banks, which lie exactly to the four cardinal points, are appropriated to a collection of such *shrubs* as are sufficiently hardy to endure the climate of Paris. The *Acacia julibrissin* or silk-tree was still in flower. This flowering specimen is now fifteen years old: at first it received protection during winter, but for several years past it has had none. An excellent specimen of crested-leaved beech (*Fagus sylvatica*, var. *cristata*), a rare variety, may be mentioned. *Spartium Scorpius* seems here to succeed in the open air; and *Virgilia lutea* evidently stands the winters pretty well. The rapid growth of some species of *Acacia* in this climate attracted our particular notice. This year's shoots of a plant marked *Robinia spectabilis* (*R. pseud-acacia*, var. *α*, of Link, Berl. Gard.), we found to be very nearly twelve feet in length, and to be still in a growing state; at the same time, each pinnated leaf was about a foot and a half long. The *varin*, regarded as a hybrid production between the common and the Persian lilac, is here a common shrub: by some curious chance (perhaps from a corruption of the French name *varin*), this variety has acquired in Scotland the name of *Siberian Lilac*. *Croton sebiferus* forms a handsome shrub, and *Pistachia Terebinthus* a tree of considerable size. *Amyris dentata* from Chili likewise appears as a tree, about fourteen feet high; but it requires protection during winter. There are several specimens of *Pyrus salicifolia* *Lin.* which is not a common plant in Scotland.

The next divisions are solely dedicated to Flora, and to Flora as admired by the crowd. All the most showy flow-

ers of the "trois belles saisons," spring, summer, and autumn, are here cultivated, many of the most gaudy being only of annual duration. The effect at this time was very brilliant; but it was chiefly produced by China asters and French marigolds having been planted out in vast profusion, and being now covered with flowers. A new kind of dwarfish China aster, closely set with blossoms of the brightest tints, pleased us much; and Mr Thouin promised that we should, on making application, be furnished with plenty of seed of it. The compartments between this and the medical arrangement formerly mentioned are exclusively botanical, and form an excellent introductory botanical school; the choice and disposition of the plants being such, that the young student can readily find illustrations of the families of plants, or of their classes and orders,—the most striking genera being selected, with species of those genera which are most easily examined, and which generally yield their flowers freely in the open air.

At the back part of the garden, next to the Rue de Buffon, and parallel to the compartments which have now been slightly described, are several successive quarters occupied by spring, summer, autumn, and winter trees, as they are styled by the French gardeners. The spring and summer quarters are separated by a walk lined with the *Ailanthus glandulosa* already mentioned. This Japan tree was now growing vigorously, and remained quite green, though standing in the hard gravel walks; while the lime-trees (rows of which extend the whole length of the garden, on each side of the central walk) had been much burnt up or nearly deprived of their foliage, by the heat and drought of last month. Here we see another desirable property of the *Ailanthus*: it will grow in the coarsest and poorest soil, and send its spreading roots abroad in search of moisture and nourishment. We may add, that it is chiefly

propagated by means of chips or cuttings of the roots, which are placed in shallow trenches, and grow readily.

The summer and autumn trees are separated by an alley, and rows of maples; the autumn and winter by a similar alley, planted with larches. The winter quarter, it is scarcely necessary to say, consists wholly of evergreens.

We had now completed our examination of the principal part of the new garden, or that which was added under the auspices of Buffon; when I left Messrs Hay and Macdonald to prosecute their investigations, having made an engagement to meet M. Lucas fils before three o'clock, which is the hour of the weekly meeting of the first class of the Institute.

L'Institut.

The meetings are held in the famous *College des Quatre Nations* of Cardinal Mazarine, now called the *Palais des Beaux Artes*, situate on the Quai de la Monnaie, opposite to the Pont des Artes. Before the sitting took place, M. Lucas kindly introduced me to Professor Desfontaines, M. Sylvestre, M. Labillardiere, and some other of the savans who were present, and who are distinguished as *agronomes*, or philosophical and theoretical agriculturists. Just as the *seance* had commenced, I was agreeably surprised to see Mr PLAYFAIR, Professor of Natural Philosophy in our University, enter the hall; and gratified to remark the attention with which my distinguished countryman and kind friend was immediately conducted to a seat near the President. The Professor had spent last winter in Italy, and was now on his return to Scotland*. The meeting was full; even those members most advanced in years seeming to make a point of giving attendance.

* We regret to have to add, that, like several other distinguished persons whom we have had occasion to mention, Professor Playfair has since died,—in July 1819.

As soon as the sitting broke up, I got into a fiacre, and soon rejoined my companions in the Jardin. After dining in one of the garden cafés, we resumed our examination, beginning where we had left off, or exactly at the centre. The cross central walk, we may notice, is distinguished by rows of *Sophora japonica*, tulip-tree, *Koelkreuteria*, and hawthorn; the last two having their heads pruned to the shape of balls and umbrellas, so as to afford specimens of the almost exploded topiary work of a former age.

The central quarter is occupied as a nursery for forest trees and shrubs, the rarer of which are sent to every part of the kingdom as wanted; and particular beds are appropriated for exemplifying the different practices resorted to in propagating them; such as layering, budding, grafting by approach, &c. Several beds have been prepared with a light heath-soil, and planted with *Rhododendrons*, *Azaleas*, and *Kalmias*, all of which are included, in the language of French gardeners, under the name of *rosages*. The climate of Paris does not seem well suited to such plants; for it is certain that the rosages of the Jardin des Plantes are excelled by those which may be seen in the "American ground" (as it is called) of many a Scottish garden.

On the side next to the Rue de Buffon, there is, first, a small quarter employed also as a nursery for fruit-trees and shrubs, or rather intended to exemplify the raising of these from the seed. Then, a space is dedicated to hardy biennial plants, and to some perennial flowers peculiarly adapted to parterres. Another space is set apart to annual plants. The number of these last is very great; many species from the Levant, and from Peru and other parts of South America, ripen their seeds here, and can thus be reproduced from year to year; while, in Britain, we have not, in general, sufficient climate to bring the seeds

to maturity, which must, therefore, either be ripened in greenhouses or yearly imported. Great attention, we may remark, is even here paid to promote the ripening of the seeds of the more tender and late flowering kinds, by covering them with hand-glasses. The brilliant dark orange flowers of *Cacalia sonchifolia* appeared under glass; but some of the South American species were, even at this late period of the season, in singular beauty, without any kind of protection.

Next to the collection of annuals, we found a rural café, with its little garden, a neat lawn, and a series of small woods or groves, with shady walks, extending to near the Museum buildings. In these pleasing retreats, family parties, accompanied by numbers of lively well-dressed children, may almost always be seen amusing themselves.

An extensive nursery for hardy perennial plants, suited to the open air in France, occupies the rest of the central part of the garden, extending from the cross-walk bordered with tulip-trees already mentioned, all the way to the court of the Museum, and including within its boundaries the circular pond, already noticed, for the culture of aquatic plants. From this rich store of duplicates, collections of plants are occasionally sent to public gardens in different parts of France. A botanic garden newly established at any provincial town, can thus be furnished at once, by an order of Government, or by the bounty of the immediate directors of the garden, with a great assortment, accurately named.

Opposite to, and parallel with the nurseries for trees, shrubs and perennial plants, which have now been mentioned, and next to the *serre tempérée* and other garden buildings, is situate the General Botanical Collection, arranged according to the Natural Method of Jussieu. This is the

most extensive compartment in the garden, occupying altogether between two and three acres of ground. It forms by far the most complete botanical arrangement of living plants which we ever beheld. The plants are divided into classes, families or orders, genera and species; and the respective boundaries of these divisions are marked by tallies of different sizes, with the name of the class, the order, or the genus inscribed. There are 15 classes, 102 families, 1428 genera, and 7268 species, at this time in the arrangement. Here the principles of association adopted, require that trees and shrubs should be intermixed with herbaceous plants; perennials with annuals; hardy plants with those which require the greenhouse, or even the stove during winter; such tender plants being adopted only in cases where a hiatus would otherwise occur in the arrangement. Many plants must of course be yearly supplied in the months of April and May. All the specimens of arboreous plants are young; when they get too large for their station here, they are transplanted to the *buttes* or hillocks, situate in the ample space which intervenes between the hot-houses of the garden and the dwelling-houses of the Professors, next to the Rue de Seine St Victor. The tender plants are retained in their flower-pots, these being merely sunk in the ground. In some cases pans with water, containing aquatic plants, are introduced into the arrangement, to render it more complete. Plants which flower very early in the spring, or very late in the autumn, many exotic plants, and many alpine rarities, are not introduced. All plants which have not produced their flowers, and the appropriate place of which in the system is of course unknown, are necessarily excluded. The collection of species of live plants now in the garden, may therefore be estimated as considerably exceeding 10,000.

Seldom does a plant appear without a tally, either telling its name or indicating its number in the garden catalogue; the greatest attention being every where paid to the conveniency and advantage of the student. In some instances, the tallies are of wood, with an iron-stalk; in others, they are of hammered iron. In general they stand about a foot and a half high, and the surface is made to slope at such an angle, that the writing can be read with ease.

A kind of large hand-glasses, or small frames, which are much in use in this garden, being of a commodious form, deserve to be noticed. They are made wholly of iron, are generally square, and at the base have four prongs, which sink into the soil, and prevent their being overturned by the wind. The roof slopes; so that, in the centre, the height is about three feet, while the sides are only a foot and a half high. There are four handles at the sides, for the conveniency of lifting the frame. Air is admitted by means of one hinged pane in the front, and another in the roof, on opposite sides. These glazed frames are frequently employed for promoting the ripening of the seeds of the more tender kinds of annual flowers, and for preserving the seeds of other plants from being destroyed by wetness in rainy weather. At this time, several were in use for a very different purpose,—to prevent the ripe seeds of the covered plant from being wafted over the garden by the autumnal breezes.

After a fatiguing but pleasantly spent day, we found that still another visit would be necessary to this admirable establishment.—We felt much pleasure in passing part of the evening in the house of Professor André Thouin, along with him and his brother M. Jean Thouin. There is a third brother, whom we did not see, M. Gabriel Thouin, who is regarded as the first *artiste jardinier* of France.

Sept. 23.—To-day we accompanied some friends in an excursion to Malmaison and Versailles. We left Paris by the same route as on occasion of our visit to St Germain. Some pretty extensive plantations of rose-trees to-day caught our eye; and we are told that these are cultivated, like those of Nordwyk in Holland, solely for the sake of the flowers, which are employed in the manufacture of rose-water, and in making conserves. Some cherry-tree plantations likewise appeared; but the great *cerisaies* which supply Paris with cherries, are situate chiefly near Montmorency. In driving along, we found from repeated experience to-day, that the "rule of the road" is very different in France from what it is in Scotland: on meeting with a carriage, it is the duty of the traveller here to hold to the right, and not to the left as with us. The driver of a gig, we also remarked, sits on the left, which, we should think, must sometimes prove rather incommodious for a friend seated on his right. In a field near Ruel we were not a little diverted at seeing a woman managing a plough, and laying her shallow furrows with tolerable regularity.

La Malmaison.

On arriving at this charming place, we first viewed the house which had been the chosen residence of Buonaparte and Josephine. The Emperor's recollections seemed to linger on those halcyon days; for to this favourite retreat he resorted, after a lapse of years, when, upon his return to Paris in June 1815, his affairs became utterly desperate. On that occasion, he left this house only a few hours before some of the Prussian cavalry entered it. The damage done by these exasperated soldiers was pointed out to us,—mirrors smashed, paintings slashed, and the escrutoire at which

Buonaparte wrote broken open and shattered, in the search for gold.

The grounds at La Malmaison were originally laid out by Morel; but they were greatly altered, or re-cast, and brought into their present character, by Blaikie and Hudson, to whom the reader has been already introduced. There is here a near approach to the English style, which seems to have been the object of ambition. Although the grounds are now in some measure neglected and out of repair, they are still very fine; the situation is admirable, and the climate delightful. As a slight illustration of this last characteristic, it may be noticed, that the Indian sage (*Salvia Indica*) has evidently naturalised itself in the shrubberies, and springs up even on the outer hedge-banks.

On the lawn near the house are scattered irregularly, but with good taste, many large specimens of *Magnolia grandiflora*, *Pinus palustris*, *Ligustrum lucidum*, *Melia Azedarach*, and several other uncommon exotic trees and shrubs. During winter, the greater part of these are protected by having wooden huts erected over them. The boards of which these huts are composed, are at this season kept in store; and, being regularly numbered, they can be put together and erected around the trees very speedily, at the approach of winter, or whenever severe cold threatens to set in. The frost, though generally of short continuance, is often more intense here than in Scotland; and, therefore, for the more tender trees, the boarded walls are made double, and the interstices filled with straw. The bright and warm summer and mellow autumn ensure the ripening of the wood of the trees, and promote the formation of the buds for the following year; so that the plants suffer their five months confinement within the board-houses with comparative impunity. Soon after the middle of April they

are relieved, when the buds are swelling and ready to expand.

In a sheltered spot, a sweet-orange tree has been planted *en plein vent*, and allowed to spread its branches with the freedom and elegance of nature. A gentleman present, who had been in Spain, informed us that this specimen was nearly of the average size of the orange-trees of that country. To us it formed a novel and very pleasing sight. During winter it is protected by a large temporary wooden structure, similar to those just described, excepting that some glazed frames are introduced for the admission of light. There are also dispersed on the lawn a good many healthy and luxuriant orange-trees in boxes, with their heads clipped in the usual way. Some of these are perhaps not inferior to the largest at the Tuileries gardens. The *caisses* in which they are planted are square; about $4\frac{1}{2}$ feet in breadth, by the same in height; and have a moveable pannel on one side, by means of which the state of the roots can be examined, and the soil renewed or improved when judged necessary.

In the time of Josephine the flower-garden was among the richest in Europe; for that Empress was an unwearied patroness of botanical collectors, who in their turn enriched the garden at La Malmaison with their vegetable treasures. Here many plants new to the northern hemisphere were first raised from seeds brought from Australasia, by the navigator Baudin. These and other rarities were figured and described by Ventenat, in a splendid work entitled "Jardin de la Malmaison," published about the year 1808. Ten years afterwards, the celebrated botanist Bonpland, the companion of Humboldt in his travels, published the first volume of a magnificent work, in folio, under the title of "Plantes rares cultivées à Malmaison." The work had been some years in preparation at a very

This is the plan of the church of St. Andrew, Malden, as it was in 1820. It is a simple rectangular building with a nave, chancel, and two side aisles. The nave is divided into three bays by two piers. The chancel is at the west end and contains the altar. There are two staircases, one at each end of the church, leading to a gallery. The plan is labeled with letters A through N. A scale bar is shown below the plan, indicating a length of 5 feet.

1820 for the Hort. Soc. P. 300

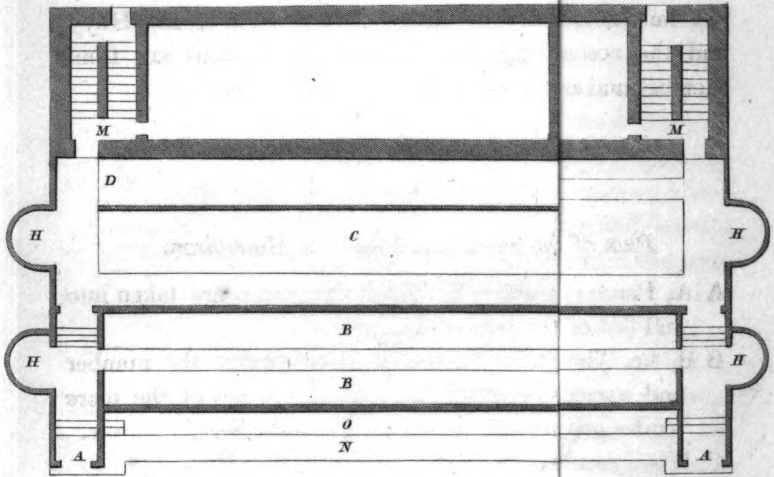

Drawn by John May

Engraved by W.H. Lacey

great expence, which was incurred by M. Bonpland in the confident expectation of reimbursement and reward; and certainly these expectations would not have been disappointed, had the Empress lived. But unfortunately she died; and her heirs cared little about plants, botanists or artists. The whole expence devolved as a personal debt upon the excellent author, who, thus ruined in his circumstances and prospects in Europe, was compelled to seek an asylum in America.

The extent and magnificence of the glazed houses could not fail to attract the particular attention of Mr Hay; and the accompanying plans and descriptions are from sketches and notes which he took on the spot.

Plate V.

Plan of the great Hot-houses at Malmaison.

- A A, Porch entrances, by which the plants are taken into and out of the houses.
- B B, &c. The stoves for tender exotic plants, the number and variety of which are great. A few of the more tender greenhouse plants are also kept here.
- C, The greenhouse.
- D E, From D to E is an inclining plane. At E it falls to the depth of seven or eight feet. It was at this time unoccupied; but it seems probable that tall greenhouse plants in pots or boxes are placed on the inclined line, according to the height of the respective plants. It is quite possible that it may also serve as a passage to the furnaces.
- F, Grand entrance to the back range of hot-houses. See the section at *g*.
- G, The conservatory.

- H H H H**, Four semicircular recesses which seem intended to receive chairs, with plants in flower placed around them.
- I**, Large apartment, elegantly fitted up for the reception of company. Here the choicest plants were exhibited as they came in flower.
- K**, Small apartment, in which the Empress Josephine used to take coffee in the afternoon. It is ornamented with some natural curiosities.
- L**, Similar small apartments.
- M M**, Stairs leading to the different storeys, seen in the section, and to the roof of the hot-house.
- N O**, Pavement walks.
- P**, Pit filled with earth, and planted with greenhouse plants in the conservatory style.
- R**, Fountain or stream of water.
- S**, Circular sofa-seat, covered with crimson velvet, and hung with gold fringes.

Plate VI.

Section of the great Hot-house at Malmaison.

- a**, Section of glazed porch at the east and the west end of the hot-house.
- b**, Paved walk, three feet broad, elevated one step above the gravel-walks.
- c**, Another paved walk in front of the glass, elevated four steps above the gravel-walk, which is the level of the door of the first range of hot-houses.
- d**, Pits for tender exotics sunk in tanners' bark, and stands for greenhouse plants.
- e**, Flues beneath the pavement-walk in the middle of the hot-house.

PLATE VI.
SECTION OF THE GREAT HOT-HOUSES AT MALMAISON.

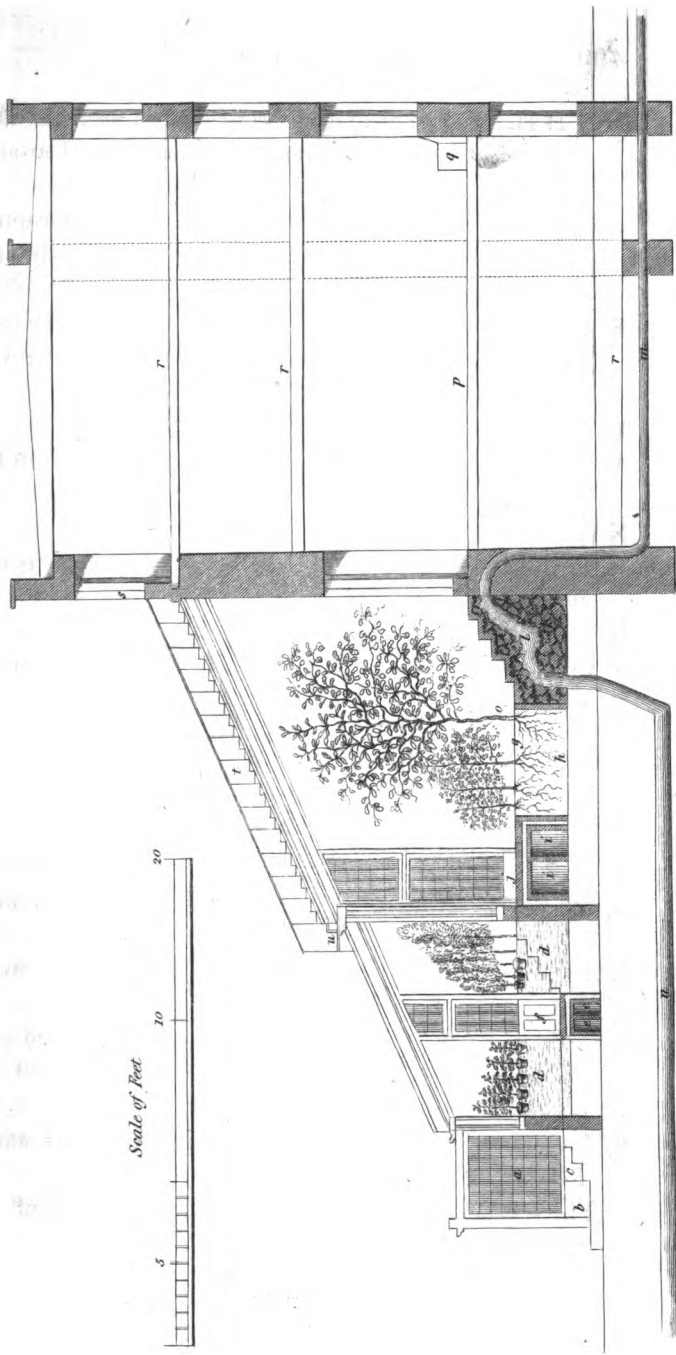



- f*, Door, shewing the height of the glass in the first range of hot-houses.
- g*, Level of the floor of the grand entrance to the second range of hot-houses, placed four steps above the first range.
- h*, Pit for conservatory plants, P on the plan.
- i i*, Flues below the pavement-walk.
- j*, Door showing the height of the glass in the second range of hot-houses.
- k*, Artificial rock-work, containing some tender succulent exotics.
- l*, Small stream of water, R on the plan, dashing with considerable noise among the rough stones.
- m*, Pipe of five or six inches bore, conducting the water to the rock-work.
- n*, Drain for carrying off the water, after it leaves the rock-work, to a pond in the pleasure-grounds.
- o*, Large plant of *Acacia floribunda* overhanging the rock-work.
- p*, Floor of an elegant room for company, with a bow in the centre, raised four steps above the floor of the second range of hot-houses.
- q*, Circular sofa-seat, S on the plan.
- r r r*, Floors of the different storeys in the back-building.
- s*, Range of windows, in regular order the whole length of the hot-houses, the end ones serving as doors, at the top of the stairs MM on the plan, to give access to the roof.
- t*, Narrow stair at the east end, giving access to the roof-glass. There is a similar stair at the west end.
- u*, Narrow gangway, running the whole length of the conservatory on the east, and of the greenhouse on the west.

Mr Hay had not above half an hour to take the principal lines of the plan and section, so that it was necessarily done in a hurried way: indeed, none but a person habitually practised in such matters could possibly have accomplished so much in so short a space of time.

The roof of the back part of the building is not visible to those standing in front; but the range of windows marked *s*, immediately above the glazed roof, being situate near the top of the building, it seems probable that it is a flat lead-roof, as delineated in the section; and from thence the view must be very extensive and delightful.—The pipe that conveys the water to the rock-work, and the drain that carries it off, were necessarily hid; but from the nature and position of the fountain, they must be situate nearly as represented.

Although we have spoken with general praise of these large hot-houses, yet we would not be understood as recommending such structures to our friends at home. The objection consists chiefly in placing one house immediately before another, so that the front of the north house becomes the back of the south one. It thus necessarily happens, that the plants in the north house are greatly deprived of light; in fact, they can enjoy free light only from the roof-glass, the light from the south being intercepted by the foliage of the plants in the front-house, and by the double glass-frames through which it must pass. Such united hot-houses may answer pretty well in the neighbourhood of Paris, where shade is so often desirable; but certainly they are not calculated for the latitude of Edinburgh.

While Mr Hay was engaged in examining the structures, Mr Macdonald and I took a view of the plants contained in them. The collection is still very rich, although

we are given to understand that some of the best plants have been removed; while many rare ones have unavoidably perished, no adequate encouragement being given for keeping up, far less for increasing, the collection. In one of the conservatories, the original bulb of *Brunsvigia Josephinæ* was pointed out to us. It had been procured from the Cape of Good Hope by a Dutch collector, and was sent from Holland to the Empress. When it first flowered, the plant was figured in Redouté's splendid work on the *Liliaceæ*, under the name of *Amaryllis Josephinæ*. The original bulb had here produced its flowers in the early part of this season (1817): the head of decayed flowers was three feet and a half in diameter, and we could still count the remains of about fifty blossoms. The bulb, which has now been at Malmaison for about seventeen years, measures, at the surface of the soil, two feet and a half in circumference. The flower-stalk, from the bulb to the base of the umbel, is twenty inches high; it is flattish, and about three inches in breadth. There are at present no vestiges of leaves; these, as in many others of the liliaceous tribe, falling down and decaying before the flower-stem springs up. The gardener seemed pleased that we should feel an interest about this plant, and presented us with three or four of its ripe seeds*. We may add, that a specimen of this remarkable plant produced its flowers, for the first time in England, in May last, at the rich collection of bulbous plants in South Lambeth; but the flowers were considerably smaller than at Malmaison, perhaps owing to the comparative smallness of Mr Griffin's bulb.

In the larger conservatory, many species of the New Holland *Acacias* have grown very tall, so as to reach the lofty glass roof. The diversified foliage was now most

* One of these is now growing at Dalkeith Gardens.

beautiful; and in the spring, we doubt not, the exuberant production of yellow flowers must have had a very charming effect. As far as we have had an opportunity of remarking, the only collection of such trees which could bear a comparison with this, is that contained in the spacious conservatory at Milburn Tower, the seat of Sir Robert Liston, Bart. near Edinburgh.

In the other conservatory, which partakes of the nature of a dry-stove, many kinds of *Aërides*, or exotic plants which are found parasitical upon trunks of trees in tropical forests, are, or rather have been, cultivated with much pains. Stems of decayed trees have actually been planted within the house; and species of *Epidendrum*, *Cymbidium*, *Vanilla*, *Dendrobium*, fixed upon these. By inserting their roots partly in the bark, and tying some moss (*hypnum* and *sphagnum*) around the place, many of these curious orchideous plants readily grew, and some of them produced their flowers in abundance. Still, the old trunks are in several places clothed with their trailing shoots. The original plant of *Cactus speciosus* of Bonpland still exists here: it first flowered in 1811. *C. speciosissimus* produced its brilliant blossoms this season; and a fine painting in oil-colours was made from it, by Mr George Fogo, an artist of Scottish origin, now resident in Paris*.

In the stove are many excellent tender exotics. *Pothos macrophylla*, being very large, made a conspicuous appearance. The papaw-tree (*Carica Papaya*) was now in fruit.

A small greenhouse seems chiefly appropriated to the genera *Erica*, *Diosma*, and *Struthiola*, from the Cape of Good

* Both of these fine Cacti have produced their flowers in the rich collection of Professor Dunbar, at Rose Park, near Edinburgh.—Mr Fogo is now in this country, exhibiting a painting of the Surrender of Parga, executed by him and his brother.—August 1822. N.

Hope; but the number of species of Cape heaths here cultivated is insignificant, when compared with several collections both in England and Scotland. In the open border, however, several species are here planted *en bruyere*, and seem to be thriving well; those of the south of Europe, *E. arborea*, *scopartia*, *australis*, *ciliaris*, *mediterranea*, forming beautiful shrubs. Some moveable pieces of inclined lattice-work are used for shading them from the *hâle* or scorching effect of the sun.

Leaving Malmaison, we proceeded on foot in the direction for Versailles. For some way we walked along the margin of a romantic rivulet, the banks of which presented some scattered plants of goat's-rue, *Galega officinalis*, which we had not before seen in its native state. On reaching the higher grounds at La Celle, we found ourselves in the midst of an ancient plantation of marroniers, or cultivated chesnut-trees. Most of them were grafted trees, and in some instances the graft had greatly overgrown the stock: one aged tree measured, at the place of grafting, no less than $22\frac{1}{2}$ feet; while, immediately below the graft, the stock was only $15\frac{1}{2}$ feet in circumference. As we approached the Trianons, we came to the small village of Rochancourt, where dancing was going on in the open air, to the music of a solitary violin: the dancers wore favours, and of course a country-wedding was celebrated.—Entering the Park of Versailles, by the Port St Antoine, we soon came to the

Petit Trianon.

This was originally a botanical garden, where an extensive collection of plants was formed by Richard. The Petit Trianon was afterwards presented by Louis XVI. to

his Queen ; and in modelling it as the *Jardin de la Reine*, all the constituents of English or of Chinese gardening had been employed, and had been crowded together in an extraordinary manner, within boundaries comparatively limited, and with utter disregard of expence. Ponds, islets, waterfalls, cascades, rock-works, grottoes, caverns, huts, sylvan recesses, and winter alcoves, enter into its composition ; with groves of lofty trees, thickets of underwood, spreading lawns, artificial hillocks, and natural rising grounds dressed, with fine vista peeps ; while temples and obelisks succeed each other, in profusion better adapted perhaps to the French than the English taste. The picturesque, however, had every where been aimed at, and certainly not without effect. It was here that the late Queen, habited as a shepherdess, used to entertain her guests in the rural mode. The ruins of a rustic cottage, the scene of this harmless sort of royal pastime, are still pointed out. During the revolutionary period, the *Petit Trianon* palace was occupied as a kind of superior tavern, and its gardens afforded delightful scope for the celebration of the noces, balls, and *fêtes-champêtres* of the higher circle of Parisians. The place had been reclaimed by Buonaparte, and in part restored as a residence for the Empress Marie-Louise. The Bourbon liveries now again appeared ; but the taste of Marie-Antoinette seems wanting ; for marks of dilapidations and injuries still remain, which might, we think, have been obliterated even in the course of the three or four years last past.—Besides the Chinese garden now slightly described, there is another more in the French style. This contains the *orangerie*, and some nice *berceau-walks*,

Grand Trianon.

The *Grand Trianon* palace is situate at a short distance from the other, and is now included in the same general

inclosure. Here the grounds had been planned on a larger scale, and altogether in the French taste. Their beauties consist very much in pieces of water, with jets d'eau, and in marble ornaments of varied character. About thirty years ago, even the serpentine of Portsoy was in request for the adornment of this favourite seat of royalty.

So much of our day was already spent, that we could not spare time to view the Trianons more in detail. We therefore proceeded across a meadow, beautifully studded, at this season, with the flowers of the autumnal crocus, to one of the avenues leading directly to the celebrated Gardens of Versailles. On viewing the comparative sterility of the greater part of the surrounding country which now opened to us, we could not help wondering at the caprice of Louis XIV. in expending sums so vast on such a site, when he had so many richer and happier to choose among. The exterior avenues present some 'pretty large trees; but none of those planted by Le Nôtre now remain. The Virginian poplars are large and handsome. The elms are now meeting, although the roadways are very wide; but the limes are so dressed or cut in, as to form only a desirable shade over the walks.

Versailles.

We soon came to the large lower basin, called the Canal. In this piece of water, *Trapa natans*, or water-caltrops, has become completely naturalised: the fruit was now formed, and, we are told, is sometimes used at table: it tastes not unlike chesnuts, and has hence received from the French the name of *châtaigne d'eau*.

Of this wonderful place, we now proceeded to explore every compartment to which access was not denied by locked

doors. The multiplicity of objects which incessantly solicited our attention on every hand, rendered it impossible for us to take notes on the spot, during so hurried a visit. We have the satisfaction to add, however, that the pocket "Cicerone de Versailles" leaves nothing to be regretted on this score; the historical and descriptive details being both copious and accurate. This little work may be had at the shop of Mr Jacob in Versailles,—and we understand that Mr Jacob is not only the printer and publisher, but also the author of the book.

We got access to one of the inclosures which is generally shut,—that containing the Baths of Apollo, and the rock-work and cavern, constructed from designs by the celebrated painter Robert. When the *grands eaux* are in play, a waterfall dashes over this rock, and flows from the cavern,—which must certainly form one of the finest artificial scenes any where to be seen.

The central sloping lawn, commonly called the *tapis vert*, is formal, but judiciously calculated to extend an uninterrupted view from the esplanade of the chateau to the long canal. The *tapis vert* is of very considerable length, but only about sixty feet wide, and is bounded on each side by a gravel-walk. Several persons were now amusing themselves in making essays to perform blindfold the task of going from the bottom to the top of the lawn, without deviating to the walk on either side; but simple as this task appeared, no one was able to accomplish it, and the natural gestures of surprise exhibited by the unsuccessful competitors, when they found themselves stepping from the grass to the gravel, were sometimes highly amusing.

Groups and single statues, busts, and vases of admirable workmanship, are every where frequent ornaments, and gene-

rally terminate the little vistas. These seem to have escaped nearly uninjured during all the convulsions that have agitated the country. But the whole of Versailles at one time had a very narrow escape. It was proposed that the chateau, the park, and the gardens, should be sold as national property; when Mr Le Roy, the architect, to his great credit, stepped forward, and represented, that the palace might be usefully employed for public purposes, and that the garden might be rendered productive of food for the people. This satisfied the citizens: a military school was established in the chateau; and by planting some of the parterres with apple-trees and others with potatoes, the garden was saved.

There are now but few remains of the original works of Le Nôtre, in any thing like their pristine state: almost all have been renewed, or have undergone transformation: the clipped pyramidal yews form almost the only exception. His Labyrinth has wholly disappeared, and its site is now occupied by a *jardin Anglais*. His old forest-trees were cut down, and young ones planted, about the year 1775; so that very few large trees are visible from the esplanade. Groves or thickets (*bosquets*) of oaks, are common; but the trees are of small size. The general style of the place is, no doubt, retained, and does credit to the favourite gardener of Louis XIV.; for the lengthened vistas,—the straight canal, and the equally straight walks leading to it,—the clipped hedges,—the statuary ornaments,—the basins, with their superb fountains,—are all in unison, and all accord with the splendid palace which overlooks them.

The quarter containing the Bassin de Neptune is truly grand, at least in its hydraulic ornaments. Neptune in his car, drawn by sea-horses, is an admirable production: it is evident that the figures have been designed and exe-

cuted by artists of the first eminence. All was now silent and deserted around these extraordinary water-works: the water was low, and *Myriophyllum verticillatum* was seen floating about the pipes. But we were assured, and can well believe, that the effect of the *grands eaux*, when bursting into this basin, is astonishingly grand*. This water is accumulated in a large reservoir called the *château d'eau*: it is furnished from various sources; by two rivulets; by several ponds for collecting rain-water; by the Aqueduc de Bouc; and by the machine of Marly, which raises water from the Seine.

The parapet-walls of the parterres next to the palace, are covered chiefly by rows, *en palissade*, of Judas-tree (*Cercis Siliquastrum*). Many of the shoots of this season were five feet long, giving proof of the fine summer enjoyed here; and they are evidently cut in, every year. The Judas-tree, we may remark, produces its bunches of rose-coloured flowers in April and May, when the leaves are only beginning to expand: in some places a few pods now appeared.

The façade of the chateau next to the garden is very grand; and the magnificent effect of the esplanade-terrace immediately in front, surpassed even the high expectations

* On a subsequent occasion (the Fête of St Louis, 26th August 1821), I had an opportunity of witnessing the display of the *grands eaux*. The upper water-works began to play at five in the afternoon, and the lower ones continued in action till about seven, the water descending to them in succession. The Bassin de Neptune, where more than sixty jets were playing at once, had really a wonderful effect; and the scene was heightened by the many thousands of well-dressed persons, including vast numbers of English, who crowded the sloping banks, to witness the exhibition. True to the character of my country, I spoke of the expence: By proportioning the annual expence, and supposing the works to be put in action eight times in the year, the cost was stated to me as probably averaging £200 per hour.—N.

we had been led to form. The large *orangerie* below, including perhaps a space of three acres, as seen from the palace terrace, completely overwhelmed us with surprise. We looked down at once upon eight hundred orange trees! Even the extreme formality of such an assemblage of trees planted in tubs or boxes, and regularly disposed in a square formed by an architect, did not at first detract from our delight. We descended several flights of stairs, of elegant structure, and walked among the orange-trees. They consist of different varieties of *Citrus Aurantium*, *orangers* and *bigaradiers*, or our sweet and bitter oranges; of *C. medica*, *citroniers*, *limons*, and *cedrats*, or our lemons and citrons; and of *C. decumana*, the *pampelmous*, or our shaddock. They are disposed along the sides of the walks, which pass diagonally through the square; and as the only ornament in their immediate neighbourhood consists of grass-plats, the eye is not distracted from these fine plants. In the centre of the compartments, however, is a piece of water, with a jet, and two very large and richly carved vases. Around are placed some very old specimens of those ornamental trees which generally formed a part of the furniture of ancient orangeries; pomegranates, both single and double-flowered, laurels or sweet-bays, neriums or oleanders, Catalonian and Azorian jasmies, and narrow-leaved mastick-trees. We measured the stem of the largest pomegranate-tree, and found it to be no less than three feet three inches in circumference.

One venerable orange-tree deserves particular notice. It is designated The Bourbon, having belonged to the celebrated Constable of that name in the beginning of the 16th century, and been confiscated to the Crown in 1522, at which time it was a hundred years old. A crown is placed on its *caisse*, with this inscription painted below, "Semé en 1421." The

portion both of light and air can be admitted in mild weather. But the original design is objectionable; the place being naturally and necessarily ill adapted to its purpose. It has indeed no other recommendation but conveniency. Even if the ceiling could be rendered water-tight, the plants must suffer from the dampness and darkness of their caverns. But we saw evidence on the floor that moisture does percolate, and occasionally fall in drops from the roof, loaded of course with lime. That this must be pernicious appears self-evident. Considering these disadvantages, we are inclined to give the gardener, who has charge of the orangery, M. Le Normand, much credit for the healthy state in which he contrives to maintain the trees. Some fine situations, we may remark, for a detached and appropriate winter-orangery, might be found at no great distance. But we would be inclined to remove the whole to one of the lower compartments of the garden, where the plants might ornament a lawn, and be set off, during summer, by the foliage of surrounding forest-trees, instead of being immediately contrasted with massive walls of masonry. We can never forget the excellent effect produced at the Duke of Aremberg's domain, at Enghien, by the summer orangery being crowned with lofty groves.—(P. 323).

Having already learned that the orange-flowers at the Tuileries are farmed, the reader will not be surprised to hear that this is likewise the case at Versailles. The trees are let, in lots, to different people; and about 3000 francs (L. 125 Sterling) were in this way this year got for the flowers: in more favourable seasons, we are informed, a much larger sum is generally obtained. All the trees are clipped into the usual round shape, not one being allowed to assume its natural form; although we think room enough might be found in the vast winter-repository for two or three exceptions.

We had now nearly exhausted the day, without being able to view the interior of the Palace, the scene of the royal revels of Louis XIV. But this we much less regretted than our inability to overtake an examination of the *jardin potager*, of 30 acres, planned by Quintynie, and restored about thirty years ago, by an Englishman of the name of Brown, who died some years ago, in France. The flower-garden, at Port de Dragon, of Mr Feburier, one of the most distinguished French florists, is a place well deserving of a deliberate visit. Close by its gate, the first tulip-tree ever planted in France may still be seen. Versailles has long been noted for its gardeners. The "Confreres de St Fiacre" of this city are to France, what "Adam's Lodge" of Aberdeen is to Scotland,—the oldest gardeners' society in the country. The confreres have, within these few years, erected, in the church of Symphorien here, a white marble figure of Fiacre, the tutelary saint of horticulturists. The inhabitants of Versailles seem to have imbibed from Le Nôtre and Quintynie a taste for horticulture and botany. Even in the midst of the ferment of the revolution, in 1792, they applied to the National Assembly for the establishment of a botanical garden. Their request was granted, and our countryman Blaikie named commissaire for that purpose; but he declined the employment.

We dined at an excellent restaurateur's, close by the chateau, and reached Paris late in the evening.

Luxembourg Gardens.

Sept. 24.—To-day we visited the gardens of the celebrated palace of Mary de Medicis. They are much in the general style of the Tuileries; being adorned with many fine orange-trees, statuary ornaments, and a circular piece of water. The pond is large, and has an enlivening effect,

especially while its dolphin-like fountain is in action. Some swans and gulls, swimming about in beautiful plumage, add considerably to its embellishment. The water is brought in an aqueduct from Arceuil; and the water of this place, we may notice, is accounted so pure and excellent, that we heard it called through the streets of Paris for sale, in the manner in which the water of St Margaret's well, near Restalrig, used to be hawked through Edinburgh and Leith. The summer orangery is adjoining; and statues and vases of marble, placed at intervals, encircle both. In the vases, geraniums in pots are placed: the pots being in general hid or disguised, the plant appears to be growing in the elegant vase, and its foliage and flowers are directly contrasted with the white marble. The palace lies too low, or rather, perhaps, the terraces behind or to the southward, have been raised too high. The intention of the artist seems to have been, to form a gradual slope, or regularly inclined plane, from the national Observatory to the Palace; but he has sacrificed too much for the attainment of this object. While standing at the pond, it is impossible to divest one's-self of the idea, that, if the water should escape, it would enter the palace-doors, and overflow the state-rooms on the ground-floor. It was in these lower apartments, we may remark in passing, that the Directory held its sittings, and that Robespierre presided during the Reign of Terror: and in the very same apartments do some of the Royal Family now assist at mass every Sunday,—a practice, we think, not indicative of much good taste, or of much prudence.

The collection of rose-trees is here very extensive; but they are planted in formal squares, on the east and west sides of the palace, and arranged quite in the manner of a London sale-nursery. They are chiefly budded on tall

stocks of *Rosa villosa* and *R. canina*. Most of the species had this season produced abundant flowers, for there was now a plentiful crop of hews. Interspersed among the rose-trees are many plants of *Chrysanthemum Indicum*, which are now beginning to come into blossom, and which will prolong the show of flowers till the frosts of December. In the shrubbery, the hybrid *varin* is much more frequent than the common lilac, and it makes a more tractable ornamental shrub. The sward on the lawn is kept verdant by regular watering; but it is not compact or smooth. It is watered by means of a force-pump placed at the margin of the pond, to which is attached a long leathern tube, ending with a large brass-rose, such as has been already described, (p. 345.) The tube, according to its length, requires two or three men to manage it, while two are employed in pumping. In this way, the grounds, parterre and shrubbery, as well as *gazon*, to a very considerable distance around, can be easily refreshed with artificial showers when thought necessary.

Over the parapet-wall of the garden we had a view of part of the fruit-tree nursery. A cherry-tree with foliage of signal luxuriance caught our eye: we could only learn that it is called *Cerise de quat' à la livre*, and that it does not yield fruit, "ni grand, ni petit."

Pepiniere of Lacroix.

On our way to the grounds of M. Cels, we made a transient call at the nurseries of Lacroix. They proved but of the secondary order, neither very extensive nor rich in plants, and therefore need not detain us long. While we were looking at his collection of cherry-trees, the owner very complaisantly passed a eulogy on "cerises Anglais," at the same time pointing out trees, the foliage and twigs

of which rather indicated the Dutch cherry. The different Duke cherries would have been better entitled to the name of English; but these are here called *Cerises Royales*. An olive-tree planted in the open air, was now in fruit; but it requires protection during winter, and, we are told, is very liable to be cut off by the frost. Lacroix possesses a considerable stock of the double white pomegranate, which would bring a good deal of money at London or Edinburgh: The pomegranate stools endure the winter quite well in the open ground, when merely covered with straw. Some *potirons* or pumpkins had attained a large size in this garden; one was already like a little barrel, being more than six feet in circumference, and it was still swelling. The green Verjus grape-vine we here saw in great luxuriance. This variety yields very large bunches like the Syrian. It is a late grape; and the berries, generally remaining unripe in the climate of Paris, are used chiefly for making sauces, for which purpose they are considered as excellently well adapted. When ripe, they are said to be of fine flavour. Mr Hay seemed to think that this variety might prove an acquisition in Scotland; where grapes are produced only by artificial heat or under glass, and where of course the bunches of the verjus could be brought to maturity as easily as those of the white muscat of Alexandria.

We now proceeded to the Petit Mont Rouge, and entered the

Botanical Garden and Nurseries of Cels.

This collection has acquired celebrity, from its having been illustrated, about fifteen years ago, by the splendid work of Ventenat, entitled “*Choix de Plantes dans le Jardin de Cels*;” and the celebrity is well deserved. It is to

d d

Paris what the collections of Lee and Kennedy, Colvills, or Loddiges, are to London. It forms an emporium of rare and beautiful exotics, for the supply of amateur cultivators. The plants are tended with much care, and evidently managed with great skill, being generally in a very healthy state. The whole establishment has a highly respectable appearance; and this is no slight praise from persons accustomed to see the best kept nurseries in the world. The extent of sunk glazed frames, for the propagation of scarce and tender shrubs, by layering and by inarching, is very great. The circumstance of the frames being sunk, facilitates very much the means used for the exclusion of the frosts of winter, which often reach degrees of intensity little known in Britain. Mr Cels not only appears to be a very expert and successful cultivator, but we have reason to believe that he spares neither trouble nor expence in the introduction of new plants. Since the peace he has yearly procured many rarities from London. A plant marked *Gompholobii species* was pointed out to us as a novelty: it shewed, at this time, light blue flowers, in a state of decay, and we were told that plants would be ready for sale against next spring. As it is not very readily propagated, it will probably continue for some time to be regarded as rather a rare plant*. The borders were adorned with many specimens of double-flowered *Althæa frutex* (*Hybiscus syriacus*) both white and purple; *Anagallis fruticosa*, a biennial planted out during the second year, and now covered with its bright orange flowers; *Daphne Gnidium*, and other ornamental shrubs of the rarer kinds. Dahlias were common; and, at this season, the single pure white variety had a lively effect. *Mimosa speciosa* appeared rising out of a sunk pit in the most vigorous style imaginable: only

* We believe it is the *Hovea Celsi* of the Botanical Register.

the elegant pinnated foliage was seen, waving aloft with the light breezes; for some of the shoots of this season were now no less than nine feet in length.

There is one collection of fruit-trees in a nursery adjoining the botanical garden, and another at some distance; but, as far as our observation went, we would regard Mr Cels's superiority as consisting chiefly in the number of scarce, curious and beautiful exotics.

Before leaving the grounds, we had some conversation with Mr Cels in his counting-house; for he had been detained by business there, during most of the time which we spent in viewing the gardens. He spoke very warmly in praise of the rich collections of London, and acknowledged that he had acquired in that quarter some of the plants which were most precious in his eyes; particularly plants of New Holland, Nepaul, China, and the Cape of Good Hope. He expressed his happiness to hear of the progress of horticulture in a country so cold and so remote as Scotland, and his willingness to correspond with us, when our Experimental Garden should be established. We had noticed several plants of the curious variety of *Salix babylonica foliis revolutis*, which had been procured from the Botanic Garden at Ghent, where we first saw it (p. 40.): Mr Cels now remarked to us, that the revolute character does not remain permanent; in strong and rich soils he finds the leaves apt to become straight, while in dry and poor ground they continue "courbues." The *Rhamnus hybrida* or *sempervirens*, we may add, was originally raised in this garden, and resulted from an experiment of Mr Cels, who applied the pollen of *R. frangula* to flowers of *R. alaternus* which had been deprived of stamina. This hybrid variety was figured and described by L'Heritier, in the publication entitled "Plantes rares de Cels."

We returned towards Paris by the Avenue de Breteuil, and took this opportunity of viewing the

Hôpital des Invalides.

The church, which is the principal object of a stranger's curiosity, was at this time seen to disadvantage: for the interior of the Dome was now undergoing some repairs, which marred the perspective effect of the frescoes of Lafosse; inasmuch as the attention was unavoidably more engaged with the ingenious contrivance of the lofty and almost aerial scaffolding than with any thing else. The banners captured by the arms of France used to be here suspended in triumph: but these have wholly disappeared: the Invalids, on ascertaining that the Allies were about to enter Paris in 1814, tore down the whole in a sort of phrenzy, and made a bonfire of them,—so that their enemies might never have to boast of the recapture of these tattered trophies,—a feeling certainly not illaudable in veteran common-soldiers. The tessellated pavement under the dome is an admirable piece of workmanship. We noticed the tomb or monument of Vauban, whose impregnable citadel of Lille we had lately seen; and, opposite to it, that of the most renowned of the field-marshal of France, with the simple inscription “Turenne.” After viewing the spacious esplanade, with its fountain and rows of trees, we passed along Rue St Dominique to the

Champ de Mars.

Two very long parallel embankments here bound a plain, of a parallelogram form; the whole being capable of containing 300,000 people. The vast sloping terraces were the work of a fortnight, when the zeal of the Parisians, and of the deputies from the different departments of France, was roused to the uttermost, to make preparations for the so-

lemnity of the Federation in 1790. The Champ de Mars is now used for reviews of troops, and it also serves as the race-ground of Paris. The Ecole Militaire is situate at the upper end of the Field of Mars; the Bridge of Jena, a beautiful structure, at the lower.

We returned homewards by the *Allée des Veuves*, and took a leisurely view of the Champs Elysées, and their fine trees. It is scarcely necessary to say, that the public walks and grounds on this side of the capital appeared to us worthy of a great and enlightened people; they indeed deserve the epithets, often bestowed on them by the natives, of *superb* and *magnifique*. At the *Place Louis XV.* (so named from having formerly been ornamented with an equestrian statue of that monarch) the places were pointed out to us where the late King and Queen were severally subjected to the guillotine. It has been proposed to erect here a statue of Louis XVI., and to have his testament engraved on the pedestal; but prudence seems to dictate, that some few years more should be suffered to elapse, before such a project be put in execution.

Vilmorin's Nursery-Gardens.

Sept. 25.—Vilmorin-Andrieux and Company being the most distinguished seedsmen in Paris, we thought it right to visit their nursery-gardens, at No. 39. Rue de Reuilly, in the Fauxbourg St Antoine.

The grounds are of considerable extent; and we soon perceived that they here cultivate very many kinds of flowers for the sake of the seed, such as balsams, ipomœa, French marigold, lupins, gilliflowers and China asters; and also some of the rare or more tender culinary herbs with the same view, such as the different varieties of basil and capsicum, the love-apple; and, we may add, the Solanum

Melongena, the purple fruit of which we had remarked in the green-market, where it is sold under the name of *aubergine*. Many small crops of flower-seeds had been already gathered; while some of the later plants were still in flower. *Amaranthus tricolor* was planted in beds in the open air, and had, at this time, a very rich effect. The cockscombs (*Celosia cristata*) were in a frame; very large and brilliant, except where they were beginning to decay; the seed was now quite ripe. A piece of rock-work was covered with the ice-plant (*Mesembryanthemum crystallinum*): at an earlier period the appearance of this rock-work must have been very pleasing; but the leaves had now in general decayed and fallen off, and the capsules contained abundance of seed, nearly ripe. The plants were all in pots; but these were sunk among the stones, and, when the foliage was perfect, must have been wholly concealed. Spanish potatoes (*Convolvulus Batatas*) are cultivated in slightly raised beds, composed of stable-dung covered with earth. The slow fermentation thus produced promotes the growth; but the season has been so unfavourable, that the tubers will scarcely, this year, become fit for use. There are two varieties, pink-coloured and white; the last having a larger and lighter-coloured foliage. Many varieties of gourds are raised here, and at this time the fruit was beautiful. We also remarked different kinds of melons; some of them remarkably large,—a specimen of the Coulomier being no less than 3 feet in circumference, and weighing 32 lb.—The perennial bunias from Russia (*Bunias orientalis*) seems to be an object of culture, for the sake of the seed, or of selling in the state of young plants. The gardener told us, that the leaves are used for feeding cows and sheep. This may be worth attending to.—A kind of Savoy cabbage, with a flower-stem which

preserves the pyramidal form with the utmost symmetry and regularity, caught our notice: it is called the *choux palmier*, or palm-cabbage. Large plants, now in flower and seed, were from 6 to 8 feet high; but even young plants look very pretty. This curious variety is much more ornamental than useful; and it is not very permanent: When raised from the seed, therefore, only the most genuine seedlings should be preserved, all those which shew a tendency to sport being cast out: it is evident, also, that seed should be collected only from the most characteristic specimens.—There were here trained against a south wall, many plants of the curious papilionaceous flower, *Phaseolus Caracalla*, or snail-flowered kidney-bean: the plants were in pots; but so backward, that unless they be speedily transferred to the stove, they cannot be expected to ripen their seed this season.—*Festuca glauca* is a good deal used in this garden for forming an edging, and it makes a very pretty one.—Several of the borders were still covered with chopped straw, which is thrown on, during the heats of summer and autumn, to keep the surface of the soil from being over-parched by the drought and heat. Indeed, this is not an uncommon practice in gardens near Paris, where neatness of appearance is sacrificed to the more important object of keeping the surface loose and somewhat moist.—The collection of roses is large; but the season of the flowers being wholly past, we could judge only by the number of the stools and tallies. Several quarters are occupied with *Robinias*, *varins*, cypresses, &c. in nursery lines; and others with young seedling forest-trees. These, when sold by tale from the lines, are technically called *pourettes*, a name originally applied to young mulberry-trees. Some attention is here paid to the raising of new pear-trees from the seed. Several seedlings regarded

as of promising character were shown to us, now in fruit for the first time. There are, scattered up and down the grounds, a few good specimens of ornamental forest-trees of large size: one of the most remarkable is a *Gleditschia triacanthos*, about 30 feet high, with a stem $8\frac{1}{2}$ feet in girth.—Little attention, we may remark, is paid to general neatness in the keeping of Vilmorin's grounds. The nursery-gardens near Edinburgh, particularly those of Dicksons and Co., Eagle and Henderson, and Dicksons Brothers, are incomparably superior in that respect, to similar Parisian establishments.

At the Place du Trone, in the neighbourhood of Vilmorin's nurseries, we procured a fiacre to take us to Montreuil sous-le-bois, about three miles distant to the eastward, on the rising ground above Vincennes. On this excursion we were accompanied by Mr Wood, from Kew Garden*.

Peach-Gardens of Montreuil.

This place presented a very uncommon scene, being wholly covered, to the extent of several miles, with small walled gardens, and the walls in general being of a dazzling whiteness. As the production of peaches for the supply of Paris is the great object of the cultivators, and as the different kinds of peach-trees require the aid of walls with different aspects, the number of walls is intentionally multiplied; one garden sometimes being subdivided or intersected by four or five or more walls, besides those necessary for its enclosure. The aspects preferred are generally those turned somewhat from the south; indeed S. E., E. and S. W. may be regarded as the favourite aspects. The

* Now gardener to Charles Cooke, Esq. of Upper Poole House, Herefordshire.

precoces or early peaches occupy chiefly the eastern aspects, where night-frosts do not prove so detrimental, and are dispelled betimes by the rising sun. The *tardives* or late peaches require the full south, or an aspect near it, where they may get all the sun possible, and with its most powerful influence. The western aspects are principally occupied by cherry-trees, plum-trees, and early grape-vines. Along the borders on the northern side of the fruit-walls, dwarfish filbert-nut trees are often planted, and seem to do well. On the narrow borders in front of the peach-trees, no kind of crop is ever raised, not even salad vegetables. All the peach-trees are *basse-tiges*, or what we call *dwarfs*. The subsidiary walls are from 80 to 100 feet long; and even when they are parallel to each other, which is not, however, often the case, they are not more than forty or fifty feet apart. Of one of the most regular of these gardens Mr Hay made a ground-sketch; and this will perhaps give the reader a more distinct idea of their nature and appearance, than any verbal description. But he must remember, that in many of the gardens the walls are more inclined from the south than in the one represented, and that in very few of them are they placed at such equal distances from each other. In some, indeed, they seem to have been set down in the most capricious manner: they have evidently been built at different times, probably according to the abilities of the cultivators,—without any preconcerted plan, and with a total disregard to regularity of appearance. One advantage considered as resulting from the multiplicity of walls in various directions, is the retaining of moisture on the surface, and thus moderating the burning nature of the soil.—In the sketch, the stronger lines represent the walls; the lighter lines, the alleys. Besides the inclosure-walls, there are three long cross ones, with E. and W. aspects; fifteen subsidiary walls, with a full S. aspect; and five inclined a little to the W.

Plan of one of the most regular Peach-Gardens.

West.

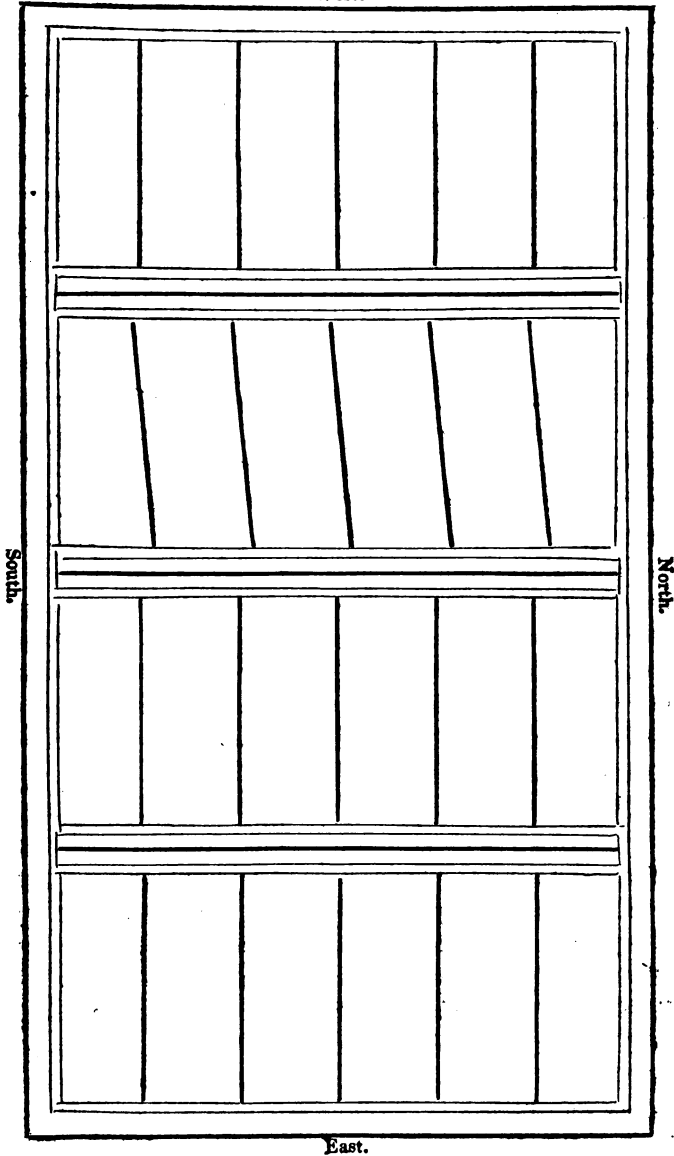

East.

The interior walls are in general between nine and ten feet high ; very slim, being only about fifteen inches in thickness at the base, and tapering slightly upwards. They are roughly built of small stones, with mortar made from the garden-soil ; and they are plastered on both sides with gypsum, which is found in the immediate neighbourhood. The plaster soon becomes so very hard and firm, as sufficiently to retain nails driven into it. The outer-walls are not in general higher than those of the interior, but in some cases they are a little higher. These inclosure-walls are only rough-cast on the outside, but are plastered with gypsum on the inside. The soil at Montreuil consists of a light loam, incumbent on rock-marl, with which it is of course intermixed. This we should not be inclined to consider as a very favourable soil.

We called at the house of M. Lorient, one of the peach-growers. He was unluckily from home ; but his garden was shewn to us. The trees are in general young and small. They are trained fanwise, or “ en V ouvert ” as it is here termed, with two main branches, and two or three subordinate branches. The branches and twigs are attached immediately to the wall, without the intervention of any treillage. This mode of fixing the branches directly against the wall, although common in Scotland, we have not before seen practised in Holland, Flanders, or France. Shreds of woollen-cloth and nails are used, as with us : the shreds are called *loques* or *loquettes* ; the nails are of cast-iron, and made at Charleville. The trees are placed at various distances from each other, eight, twelve, or fifteen feet, according to the size of the plant ; a few of the larger and spreading trees requiring nearly double those distances. In a garden where productiveness must be the paramount consideration, we could easily find an apology for irregularity in the size and appearance of the

trees; but they seemed to us to be rather carelessly and clumsily managed. Some of the original trees had probably died out, and a large tree had been replaced by two unsightly small ones. The crop was nearly past; only a very few *tardives*, chiefly Bourdines, and some *peches lisses* or nectarines, now remaining.

In walking through the village, our attention happened to be attracted by some uncommon flower growing in a cottage-garden; and having stopped to look at it, we were kindly invited by the mistress of the adjoining house to enter and view the garden. We did so, and had reason to be much pleased with the hearty good will and politeness of our hostess. Perceiving that we were over-heated, she proffered such cooling refreshments as she could immediately command; cut some bunches of early Madaleine and Chasselas grapes from vines trained against the gable-wall of the house; and drew some wine from a barrel of vintage 1815, now almost two years old, which we found very good. Upon our inquiring for the garden of Mr. John Mozard, she called her daughter, a young woman of twenty, to assist in giving us a proper direction; and this last, after describing its situation, said that, as we might still have difficulty in finding it, she would herself conduct us to the spot. To the credit of these people we add, that it was with no little difficulty that we could contrive to leave some remuneration for their hospitality. The name of our hostess was Bausse, the wife of a mason; and they had given their daughter an education fully equal to their circumstances, for, in the course of our walk, we discovered that she knew the horticultural publication of Mozard * (which had never been heard of at M. Lorient's);

* "Principes pratiques sur l'éducation des arbres à fruits, et principalement du Pêcher," 8vo, 1814.

and she made various inquiries about England and Scotland, evincing a more correct knowledge of the geography of these countries, and of their principal productions, than we had found in persons whose opportunities might justly be considered as greater.

We found John Mozard to be an old, but still an active man, full of horticultural zeal, and happy to exhibit his garden and his peach-trees to strangers. He is, we believe, the veritable successor of Peter Pepin, distinguished as having been, for half a century, from about 1720 to 1770, the most extensive and successful cultivator of peaches for the Paris market. Mr Mozard's peach-trees are evidently better managed than those in the garden which we first visited, and we have reason to believe that they afford a fair, if not a favourable, specimen of the culture at Montreuil. We remarked that here the stocks are uniformly of almond-tree; while, in Britain, we almost exclusively employ plum-stocks. This drew some remarks from Mozard. He mentioned, that in dry soils, such as that at Montreuil, almond stocks answer best, but that where the soil is strong and black, or a *humus*, he would give the preference to plum-stocks. A damp or wet subsoil he regards as peculiarly unfavourable for peach-trees. If the tree vegetates strongly, but is subject to gum, transplanting is the remedy resorted to at Montreuil. When a tree gets sick, an upright branch is allowed to rise from the stock; this is treated as a new stem, a peach-bud being introduced upon it, to supplant the tree which threatens decay.

Mozard's mode of training and managing young peach-trees, from the first year, may here be slightly noticed. In the course of the winter season, he cuts over the young tree about half a foot above the graft, leaving four or five buds, to produce as many branches. In July following, he cuts out, close to the main stem, all other branches than those

absolutely needed for-furnishing the tree. He trains regularly to the right and left; but the weaker branches receive less inclination, or are placed more upright, than the stronger ones, that this more favourable position may give them energy and bring them to an equality of vigour with the stronger branches which are laid in horizontally. At the first regular pruning or cutting-in, about a year and a half after planting, the branches are reduced to two on each side; and at the next pruning, one branch is removed on each side, leaving the tree to be formed only of two principal branches, and these the most equally balanced as to general force and promise. If the first year's growth do not yield two sufficiently good leading branches, they are sought from the growth of the second year; the best branch of the former year is now, with this view, trained upright as a stem, and two leading branches or arms are derived from it in the succeeding season. In subsequent years the pruning is conducted on similar principles. It is a common rule, to leave two secondary arms, each of nearly equal strength, and about two feet apart, on each side.

The subjoined outline of a tree, three years trained, is taken from a sketch by Mozard himself.

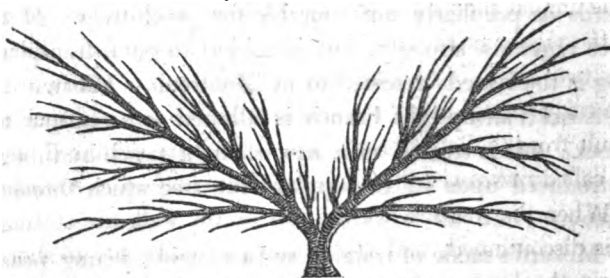

Here, it is to be remarked, only the principal and secondary branches, and a few branchlets, are represented; many twigs and annual shoots being left out. This is also the case with all the figures in Mozard's book, which, although

they may not, at first view, seem to correspond with the trees on his walls, do in reality correspond very nearly, when divested, in imagination, of the small twigs, summer growth, and foliage.

In trees managed in the way now described, the sap seems to be very equally distributed ; at least, the trees exhibit, upon the whole, a great equality of branches, both as to size or strength, and as to furniture of twigs, leaves, and fruit. Continued care is exercised to keep both sides of the tree equally balanced as to vigour. If one principal arm become stronger than the other, a few robbers are allowed to push for a time on the weak arm, with the view of drawing an increase of sap to that side of the tree, till the equilibrium be restored : or, the weak arm is altogether raised a little more towards the vertical, while the stronger is depressed more to the horizontal ; and thus an equality is gradually accomplished. The *lambourdes* or *robbers*, it may be added, with due management, frequently afford the healthiest and best wood. They are cut down to a foot and a half, leaving one or two buds as near as possible to the trunk of the tree : the resulting shoots are laid in, and form good fruit-bearing wood the next season. The annual shoots are left of different lengths, according to the vigour of the tree, from one foot to three feet. There are two kinds of shoots ; such as are the produce both of the early spring and of the summer flow of sap, and such as result from the latter only. The former are preferred, and are called *rameaux* ; the latter are distinguished as *ramilles*.

When the tree reaches the top of the wall, the cutting-in is discontinued, and the pruning extends only to shortening the leading shoots, or, in some cases, bending them, till they be confined, by two or three inches, below the coping of the wall. In this way the equable distribution of the sap in the central parts of the tree is promoted. In

the regular course of pruning, all branchlets that shew fruit-buds only, or are thought to contain no others, are sacrificed without mercy. This would appear absurd to any one not a horticulturist, but, if such branchlets do exist, their excision is quite prudent; for *wood* buds or shoots are like pumps, to draw sap towards the branchlets; and if they be wanting, the blossom on the twig commonly fails to set; or if the fruit form, it soon falls off, or, at all events, is deficient in size and flavour. From four to eight *flower*-buds are left on each twig, according to its strength, and a *wood*-bud at the extremity, when it can be there had, or between two flower-buds near the extremity. When this wood-bud expands into a shoot, the shoot is shortened to an inch or so in length, and this remains as the pump for drawing sap to the four or eight fruit-buds of the twig. Other wood-shoots (as they are called), which may appear below the fruit-buds, or nearer to the main branches, are cut down to one or two eyes. Mr Mozard likewise resorts to disbudding, although little or no notice is taken of that practice in his work. From the style of this publication being so different from that of Mozard in conversation, we conclude that it had been *redigé* by some "slender clerk," not a practical horticulturist, and probably not aware of the importance of disbudding.

The trees in Mozard's garden are, in general, very free from canker or gum. When the bark of a tree meets with an injury, or when an abscess occurs, the diseased part is cut out; and the simple "onguent de St Fiacre," composed of cow-dung and loam, is applied, much in the same way as practised in Scotland.

The inclosure-walls on the side next the trees have a coping, sometimes of stone and sometimes of timber, projecting about four or five inches. On the subsidiary or interior walls, the coping projects on both sides. The trees

life in this way sheltered to a very considerable degree from hoar-frosts, especially in clear still nights, when the rime falls quite perpendicularly. Besides the hoar-frosts, violent and cold winds in the spring season are the only evils dreaded by the Montreuil cultivators. Mozard's garden, like most of the others at Montreuil, have rather a high situation, and *brise-vents* are found very useful. With this view, they frequently erect, at short distances from each other, small pieces of masonry, jutting out at right angles to the peach-tree walls. Similar projecting brize-vents may be seen at the corners of square walled gardens, laid out by Mr Hay in Scotland; and the utility of these in defending the crop of fruit on the outer side of the north wall of such gardens (which, of course, has a valuable south aspect) is very evident.

Some of the trees in Mozard's garden are of considerable standing, probably from twelve to twenty years old. Such trees extend over a space of perhaps thirty feet, measuring from the extremity of the branches on one side, to the extremity on the other. Early cherries are here cultivated to some extent; and M. Mozard mentioned that this is a crop which pays well at Paris in the month of May, and that the cherry culture is of course gaining ground. The *Cerise precoce* is succeeded by the *Cerise de Hollande*; but even the Dutch cherries are sent to market in the end of May, whenever they get red, though far from being ripe; being generally formed into bouquets attractive to young persons. The early apricot (*Abricot precoce*) follows the cherries; and the few sent from the walls of Montreuil are commonly in the market by the end of June. We may take this opportunity of mentioning, that at Paris the apricot-tree is principally trained as a standard, or is planted *en plein vent*; and it is here remarked of apricots, as of some pears in Scotland, such as the *muirfowl-egg*,

that the fruit from standards is more delicious and higher flavoured than that from wall trees.

One criticism we cannot help making,—that both in Lorient's garden and in Mozard's, the peach-trees are uniformly planted too close to the base of the wall: in many of the older trees, the stems may be remarked to have pressed against the wall, so as to have become flattened behind; and in several places the walls have been pushed off their perpendicular, by the pressure of stems and the swelling of root-stocks.

In Mozard's garden, also, the peach harvest was almost past, only a few of the Maltese and 'Teton de Venus remaining. The Bellegarde, we are told, is one of the peaches most generally cultivated at Montreuil, and M. Mozard thinks that it withstands the spring frosts better than most others. We were led to think that this Montreuil Bellegarde is our Gallande; but Mr Macdonald has two distinct peaches under these names at Dalkeith Park. Perhaps the *Pêche noir* of Montreuil is rather our Gallande?

There are here cultivated also, on paradise stocks, a few apple-trees, of select kinds, the fruit of which is ornamental in desserts. The Canadian rennet was at this time beautiful, and very large; one which we measured, being fourteen inches in circumference.

When we had finished our inspection of his garden, we were invited by M. Mozard to enter his dwelling. Here we found his wife, and some other females, busied with the shelling of kidney-beans. The beans are dried, and stored up in large quantities against winter, when they are sold under the name of *haricots blancs*. One variety was kept separate, under the name of *mange-tout*, the legume having no inner film, and the seeds being not of a kidney shape, but round, though flat on one side. M. Mozard now produced to us, with evident satisfaction, some honor-

ary marks of distinction which he had received as being an eminent Montreuil cultivator; particularly a gold ring from the Emperor Alexander of Russia, a medal from the Agricultural Society for the department of the Seine, and a letter and book presented to him by our patriotic countryman Sir John Sinclair.

M. Mairiette may be mentioned as another excellent cultivator at Montreuil; indeed, he is regarded by many as fully on a par with Mozard, and he also lays claim to the honour of being considered successor to old Pepin. M. Savard is a third cultivator of great merit, and has very extensive suites of garden-walls.

We spent most of the day in this curious and pleasant village,—where not a forest-tree is to be seen, but where the horticultural eye is regaled with the view of many thousands of peach-trees, and many hundreds of cherry, plum, and apricot trees, and grape-vines. On every side, beyond the walled gardens, vineyards extend to a considerable distance around the town. The fruit-gardeners of Montreuil are all mere cultivators, and very much on a footing of equality: no rich restaurateur has planted himself among them, or engrossed several gardens: Very, Henneveau, Beauvilliers, Vefour, Champeaux, purchase from them. They may all be considered as comparatively poor, though most of them are in easy circumstances. They have few wants: they raise vegetables in abundance for the use of their own families, and they make their own wine; but on the paniers of peaches and of early cherries, &c. sent to Paris, they almost solely depend for a return in money, or an exchange of Parisian commodities. A large peach-tree, in a favourable season, will yield from 250 to 400 peaches; but the greater part of the trees being small, do not afford more than from 50 to 150 fruit each tree. The cultivators have, within the last two or three years,

extended their grounds and walls; 1000 francs are now given for half an acre of comparatively poor soil, and this is a high rate of purchase-money in France. The fruit is carried to Paris, by the females of the village, of all ages; and these set off, in bands, by 1 or 2 o'clock in the morning; for all the wholesale markets of the capital are held at very early hours.

Towards evening we returned to Paris on foot, highly satisfied with our day's excursion.

Sept. 26.—Being in daily expectation of a letter of permission from the French Government, to view the royal pepinieres and gardens, feelings of delicacy still operated in preventing us from entering them in the mean time, which we might otherwise have done without hesitation. We therefore dedicated this day to some of the sights of Paris.

The Catacombs

had excited our curiosity on a former day, when passing by the Barrier d'Enfer to the garden of Cels. We now returned to this barrier about mid-day; and after a little delay, during which we were joined by several English ladies and gentlemen, and French boys and girls were urgent enough that we should purchase wax-tapers from them, the director of the subterranean repositories appeared and threw open a door. We descended a narrow winding stair, which is about 54 French feet in depth, and consists of 76 steps. At the bottom our conductor paused, and made us light our tapers; he then counted his party, and told us some confused story of an Englishman who had last year lost himself in the labyrinths we were about to enter, and whose body was not yet found. This was probably a rhetorical flourish, intended to impress with

cautiousness the minds of his unruly charge; for the party consisted chiefly of English, and most of them young.

The great caverns here, have been produced by the quarrying or mining of thick beds of sandstone, for the supply of building-stones to Paris. They extend to a great distance below ground, passing under no inconsiderable part of the faubourgs of St Jacques and St Germain, and even under the Seine. Huge columns are left at regular distances for supporting the roof. The floor has been levelled, at least in those places to which strangers are usually conducted; so that not the slightest difficulty occurs in this gloomy walk. The only thing necessary to be attended to, is to keep within sight of the conductor's lights; for it would be very difficult for a lonely stranger to thread the mazes. A strong black line of painting on the roof, however, marks the route; so that, while a light can be kept alive, there is no real danger. It has been already mentioned (p. 347.), that the bones from the cemetery of the Innocents were deposited in the extensive stone chambers which we were now visiting. Human osseous remains from some of the ancient churches of Paris were also deposited in these caverns. The title of Catacombs was now bestowed on them on account of their supposed resemblance to the repositories of the dead among such of the ancients as did not practise cremation. This is now probably the vastest charnel-house in the world, and it is certainly the best arranged. Inscriptions here and there present themselves: some of them are far from being pleasing or soothing; one recording only the number of square yards occupied by a continuous heap of bones, and another pretty plainly intimating that these mortal remains are here destined to eternal repose,—possibly because the writers of the inscription had no wish for other prospects. A considerable number of diseased bones has been culled out,

and these now form a curious but rather disgusting collection. In the course of clearing the rubbish from the floors of the caverns, many petrifications or casts of shells and other marine bodies, were found imbedded in the fragments of the sandstone rock. These exist only in particular layers or beds of the sandstone, and the shells have evidently been very different from those now found in the neighbouring seas. These are also arranged in a recess, forming a subterranean museum. A rude model of Port Mahon, long ago cut in the solid rock by one of the quarriers who in his youth had served as a soldier in the successful expedition against Minorca in 1756, is carefully preserved, and deserves a visit from strangers. In other places, altars rise from the floor. We found that these had been hewn out, and really form part, of the native rock. They must have owed their origin to the religious feelings or to the superstitions of the quarriers; for we were assured that they existed long before the human bones were deposited, although they are now curiously adorned with skulls and thigh-bones. In a well about three feet deep, dug in the floor of the cavern, two or three gold and silver fishes appear: on the approaching of lights, they come to the surface, and, being very tame, are often fed with crumbs of bread from the hands of their visitants.

On emerging from these caverns, we returned towards the Tuileries, and entered the

Louvre Galleries.

Any details regarding the Royal Museum of Statuary and Painting will not be expected in this journal. Although deprived of its principal glories, by the just restitution in 1815 of the chef-d'œuvres, in both departments, to their former owners at Rome, Milan, Venice, Brussels, Antwerp, and other places, its extent and riches are still

admirable. Descriptive volumes have been published, and are accessible to every one. We could only walk through the apartments, glancing at the objects as we passed: to examine the statues and inscriptions alone, in a proper manner, would require weeks; for although the noblest pieces of ancient sculpture are removed, enough still remains to excite high interest. They occupy the ground floor of the Louvre, which is divided into eight halls, the entrance to each being adorned with symbols and inscriptions, making classical allusions to the precious contents before 1815. In many cases, casts of these are substituted for the originals. The paintings are up stairs, arranged in two saloons, and in the grand gallery. The vast length of this gallery and the magnificent coup d'œil certainly excited our admiration; but we could not help feeling that it is not well adapted to its purpose, owing chiefly to the way in which the light is admitted, producing in many places all the ill effects of cross-lights.

Jardin Beaujon.—Theatre Français.

In the evening Mr Hay and Mr Maconald visited the Montagnes Françaises, near the upper extremity of the Champs Elysées. This is the garden of Beaujon, now celebrated for giving *courses en chars*,—a sort of violent and rather hazardous exercise to which the English seem partial, and which it is surprising has not yet been introduced in the neighbourhood of London. It happened not to be a gala night; and my friends, I found, thought little of the place.

Meantime I went alone to the Theatre Français at the foot of Rue Richlieu, and had the good fortune to see the *Œdipe* of Voltaire admirably performed; Talma being *Œdipe*, and Mademoiselle George representing *Jocaste*. I was prepared to expect one uniform action throughout the

piece, without the shifting of scenes, or the rise and fall of a drop-painting, and the rigid adherence to the unities in these respects was far from displeasing; but certainly I was greatly disappointed at the dirtiness and worn-out aspect of the whole furniture of the stage. I perceived some striking instances of the zeal with which a French audience enters into the business of the hour. When the bitter miseries of *Œdipus* unfolded themselves, and began to overwhelm him, I found that a French gentleman next to me, who had occasionally explained some things to me, and lent me his printed copy of the tragedy, was actually sobbing and unable to make any reply to an ill-timed whisper on my part. On looking around, I saw handkerchiefs applied to watery eyes on every side, although there were comparatively few ladies in the house. But the representative of *Œdipus* uttered the language of despair with a truth to nature, that rendered it irresistible even to a foreigner who only imperfectly caught the meaning of the words*.

Sept. 27.—Early in the morning, Mr Macdonald and Mr Wood set off to visit the nurseries at Vitry, six miles from Paris on the road to Choisy. Mr Hay and I resolved on an excursion to Montmartre, and on a final visit to the Jardin des Plantes.

Montmartre

is a pleasant village, situate on an eminence to the north-west of Paris. It commands a fine view of the capital, and

* In August 1821, I had a second opportunity of visiting the Theatre Français, and was rather disappointed at finding it as dirty and dingy as before. The piece was the "*Marie Stuart*" of Le Brun; Talma representing Leicester, and Mademoiselle Duchesnois the unfortunate Queen of Scots. Although the weather was intolerably hot, the house was crowded in every part, and the audience seemed quite as sensitive as on the former occasion; the proportion of ladies, however, was much greater.—N.

is celebrated for the gypsum quarries formed in the bowels of the hill. Many marks of balls on the houses, could not fail to call to our remembrance the attack made by the Allies in 1814; but some workmen seemed to think it necessary to refresh the memories of Messieurs les Anglois on that topic, so sore to the French people. The beds of tertiary gypsum which compose the hill, have been fully and accurately described by Brongniart and Cuvier, in their Mineralogical Geography of the Environs of Paris; and any remarks on them seem unnecessary. We here saw some of the principal *guinguettes*, or public-houses with arbour-gardens, to which the lower orders of Parisians resort, to eat fruit and drink lemonade and wine. They are on a par with the second-rate tea-gardens near London. When there is the addition of an orchestra, and a dancing-green or a covered *salle à danse*, the title of *bastringue* is bestowed. The sloping grounds to the northward, to a considerable distance, are clothed with vine-plantations.

We returned towards Paris, and procured a fiacre to take us to the

Jardin des Plantes,

where we viewed some parts which we had formerly been obliged to pass very slightly over.

Among these were the *buttes*, which form the Arboretum of the garden, and at once afford shelter and produce ornament. The collection of resiniferous trees growing on the hillocks near the Amphitheatre is large and interesting, some of the kinds being rare, and many of the specimens now forming considerable trees. The Corsica pine, *Pinus Laricio* of Lamarck in the Encyclopedie, has attained a large size, and seems deserving of the particular notice of the Society. It inhabits the mountains of Corsica, and it seems probable that it will grow wherever the Scots fir

succeeds. The tree rises quite upright, and grows faster than the Scots fir; the leaves are longer and of a finer green; and the wood is heavier and more resinous*. The largest of the pine tribe on the hillocks, is a Cedar of Lebanon, *P. Cedrus*, the trunk of which measures twelve feet in circumference. The history of this tree, as related to us by Professor Thouin, is remarkable. In 1736, Bernard de Jussieu, when leaving London, received from Peter Collinson, a young plant of *Pinus Cedrus*, which he placed in a flower-pot, and conveyed in safety to the Paris garden. Common report has magnified the exploit, by declaring, that Jussieu carried it all the way in the crown of his hat. It is now the identical tree admired for its great size. During one of the revolutionary turmoils, a random cannon-ball unfortunately shattered its head: this has considerably disfigured it; but it is spreading its lateral branches very widely. The stone-pine, *P. Pinea* is about 20 feet high; the Aleppo, *P. halepensis*, between 50 and 60. The specimens of *P. maritima* and *pendula* are also excellent. The monument here erected to Daubenton is certainly not worthy of its object; while that placed to the memory of Linnæus, under the great cedar, was destroyed many years ago, and has not been restored, the pedestal continuing, however, to mark its site. We ascended the largest butte, by a winding path commonly termed the Labyrinth. At the top is a pavilion or kiosque, provided with seats; and a porter is in readiness to lend the visitant a telescope, and to point out the principal objects seen in the distance around. Between two large branches of the Cedar of Lebanon, the Cemetery of Pere La Chaise is finely seen. The sloping bank of this

* For further particulars regarding the *Pinus Laricio*, and for a minute description, taken from the specimen on the buttes by Mr Don, see Appendix, No. IX.

hillock next to the garden, is thickly covered with *Lyceum Europæum*, and, when thus supported on one side, it forms a very tolerable hedge next to the old hot-houses.

We looked into the dry-stove destined for succulents. Many were set out in the open air; but some curious cacti and stapeliæ remained. This house has a very lofty glass roof, which appears to have been raised chiefly for the sake of a specimen of *Cactus tetragonus* thirty feet in height; and from this circumstance the name of *Lanterne des Cierges* has been bestowed on it.

We next proceeded to a kind of sunk compartment of the garden in front of the large serre tempérée, where there appears to have been an original hollow of the ground. This compartment is destined to various important purposes, and is generally kept under lock and key, though readily opened to those who are curious in plants. It contains a number of hot-beds, some covered with glass-frames, and some uncovered; the first for the raising of seeds of tropical plants; the latter for such as are more hardy. It likewise contains a large pit-frame for rearing Cape and New Holland plants. Some beds are here prepared with suitable soil for the culture of the finer bulbous and tuberous rooted hardy flowers; and others for the rearing of new or little known plants, till their characters and place in the natural arrangement can be ascertained. A damp border, shaded in a considerable degree from the sun, is appropriated to plants that cannot resist the heat and drought of the open garden. A sloping bank, supported by a parapet-wall and divided into seven steps or stages, fronting to the north-east, is dedicated to the cultivation of alpine plants in heath soil. Notwithstanding these precautions, the alpine plants seem frequently to die out; and at this time a good many were wanting, which succeed perfectly well, or are regarded as of easy culture at the Botanic Gar-

den of Edinburgh. The pretty little *Linaria pilosa* has completely naturalized itself on the walls of this alpine bank.

Beyond the compartment now described is another, where the naturalizing or acclimating of plants is regularly attempted. By being thus brought together, the plants can be more closely attended to, and their habitudes more easily remarked and provided for*.

The Menagerie next occupied our attention, and with the whole arrangements and conduct of this part of the establishment we were very much pleased. After viewing the beasts and birds of prey, we passed through the Vallée Suisse, a name bestowed by the Parisians on the suite of little inclosures or parks, appropriated to antelopes, deer, goats, and similar graminivorous quadrupeds. Many of the thatched retreats or *chaumières* for the different animals have a very neat appearance, while the clean and healthy state of the four-footed inhabitants, indicates the comfort they enjoy in their confinement.

We ought to remark, that the Chevalier Molinos had the merit of planning and superintending the execution of the improved garden, with its menagerie and various rustic structures, as they now appear.

We now took leave of our obliging friend M. ROYER, whose kind attentions many of our countrymen have often experienced. This gentleman has the most complete knowledge of the English language that we ever met with in a foreigner. During the reign of Buonaparte, when intercourse with Britain was proscribed, and when English was only heard from the mouths of a few American students, M. Royer gave lectures on our language to such of his countrymen as desired to be able to read English works of celebrity in the original. He takes every opportunity of

* For further notices regarding rare plants existing in the Jardin du Roi, the reader is referred to Appendix No. X.

conversing in English; and is quick in discovering the shades of difference in the language, as spoken by Americans and Scotsmen, and by a well-educated Englishman. He holds an office in the Administration of the Jardin, and projects the publication of a descriptive history of the whole establishment*.

We have only to add, that there are no fewer than three professors immediately connected with the botanical department. M. DESFONTAINES lectures on the physiology and the arrangement of plants: he is "professeur de botanique au Museum." M. de JUSSIEU gives herborizations, or is "professeur de botanique à la campagne:" he occasionally summonses his pupils to a rendezvous at some distance from Paris, and accompanies them through forests and marshy grounds, where many rare native plants may be picked up. M. ANDRÉ THOUIN is "professeur de culture et naturalization des vegetaux:" he gives lectures, three times a week, at the early hour of 6 in the morning, on all the branches of horticulture and agriculture.

The Gobelins.

This royal establishment being in the neighbourhood, in Rue Mouffetin, we repaired thither, and spent an hour in viewing it. Here the richest and most beautiful tapestry of modern times is manufactured; and we saw workmen copying, in their looms, portraits and historical pieces by eminent painters. At the back of the manufactory is the laboratory, where the worsteds are dyed of every possible hue.

* In August 1821, M. Royer shewed me some of the printed sheets of this work. As soon as a sheet of the French edition is printed off, he translates it into English; so that the work will appear in both languages at once. Though the translation may not be uniformly idiomatic, yet it will be found remarkably free from the usual gallicisms, and will justify the encomium bestowed on M. Royer's attainments in our language.—N.

In our way home we called at the

Shop of Vilmorin-Andrieux, & Co.

No. 30. on the Quai Feraille, the best store-house in Paris for procuring seeds of all kinds. We were presented with copies of three different catalogues: 1. "des graines des fourrages, cereales, et plantes economiques;" 2. "des graines potageres;" and 3. "des graines de fleurs et de plantes d'agrément." They readily engaged to transmit to Edinburgh, when required, such seeds as might be wished for trial in the Society's Experimental Garden, and to select them of the most genuine quality. In the mean time, we ordered small packets of several kinds, chiefly *varieties* of culinary plants not known at Edinburgh, or little attended to there. Among these were the following: "Betterave rouge ronde," an early variety of red beet; "betterave jaune de Castelnaudary," the yellow beet; "cardon plein inerme," the smooth cardoon, which possesses at least the advantage of being much more easily worked amongst and tied up for blanching, than the spiny variety; "carotte violette," a purple carrot, chiefly used for giving colour to soups; "celeri nain fris ," a small kind of curled celery used in soups: "chicor e   grosse racine," the large-rooted succory, used as a substitute for coffee; the "choux palmier," which has been already mentioned (p. 423.); "choux brocoli violet nain," a very early kind of small purple broccoli; "haricot nain blanc d'Am rique," a small but prolific kidney-bean introduced by Michaux; "mache d'Italie ou regence," a variety of lamb's-lettuce, with broad tender leaves; "pois  ventail," a very dwarfish variety of pea; and "tomate en poire," a kind of love-apple with pear-shaped fruit. To these may be added the "aubergine violette ronde," a variety of *Solanum Melongena*,

which we have never seen in Scotland, but which is pretty common in the Paris market in the autumnal months. We also ordered a few of the rarest seeds of ornamental plants, Vilmorin's collection of which is very considerable*.

Vitry Nurseries.

In the afternoon Mr Macdonald returned from his excursion to Vitry, much pleased with what he had seen. The neighbourhood of this village has long been celebrated for its nurseries. They are extremely numerous, extending continuously for several miles, without any kind of inclosure; but they are individually small, the proprietors being, almost without exception, persons of very limited capital. Frequently the nursery-gardens form mere patches, surrounded by vineyards. Young peach-trees form one staple article of culture at Vitry. They are all what are technically called maiden plants; and trained to two principal branches, destined to form different modifications of the fan-shape. Some rows are worked on the muscle-plum; others on the almond. The former are intended for gardens which have a rich moist soil; the latter for such as have the soil light and dry. Young pear-trees form another staple article of produce. They are uniformly on quince-stocks; the cultivators alleging, that grafts on wild pear-stocks or free stocks, do not *take* or succeed in the soil of Vitry. Apricot and plum trees are also propa-

* On account of the Society having no appropriate garden, we were obliged to disperse these seeds among different individuals, who expressed their willingness to cultivate them. Several of them were raised with much care and attention by Mr Macdonald, at Dalkeith House gardens, and were brought to great perfection in the seasons of 1818 and 1819. Others were raised, under less favourable circumstances, by Mr Neill at Canonmills. But the want of a public experimental garden, prevented their being generally seen by the members of the Society.—It may be mentioned, that M. Lacroix, a clerk at Vilmorin's warehouse, speaks English fluently.

gated to some extent here; and in a few of the nursery-gardens, rows of pear trees also occur. We may here mention, that the principal nurseries for pear and apple trees are at Orleans, and in Normandy, and the Parisian nurserymen generally commission their apple and pear *stocks* from these districts. At Vitry all the plants are young; none exceeding two or three years from the grafting or budding. No tallies are used for marking the kinds; the Vitry nurserymen alleging, that practice enables them sufficiently to recognize these, merely by the leaves and bark. In point of fact, they cultivate only a few kinds. Their list of peaches comprizes scarcely any others than the Early purple, the large and the small Mignonne, the Red Madeleine, Gal-lande, Teton de Venus, large Violet, Bourdine, and the Admirable. This last is much in request: it is frequently called the Belle de Vitry, and is regarded by some as having originated here. The soil at Vitry is, in general, a strong rich loam. Neatness is little attended to, most of the gardens abounding in weeds; but the general aspect of the place is pleasing, and some handsome villa-gardens in the neighbourhood are kept in a superior style.

In the evening we received, by post, under the frank of Monsieur, Frere du Roi, a communication from the Compté d'Escars, inclosing a letter from the Compté de Pradel, of the ministère de la Maison-du Roy, dated 23d September, intimating, that he had given the necessary orders that the Society's deputies "soient admis à visiter les jardins dependans de la Couronne, et y trouvent toutes les facilités convenables pour remplir l'objet de leur mission." The Count also kindly sent us a letter of introduction, of an earlier date, to M. Faujas de St Fond, warmly recommending us to his notice, and requesting him to engage M. Thouin and others in facilitating our researches. The delay in our re-

ceiving these letters had arisen, we believe, from the absence from Paris, of the Comte d'Artois and suite.

Sept. 28.—Hitherto the weather at Paris had been clear, and the temperature agreeable. But rain seemed now to set in, and this morning felt so cold that we found it desirable to have our *chenet* furnished with billets, and to enjoy the comfort of a fire.

Lutheran Church.

At mid-day we went to the Lutheran Church in Rue des Billetés, and heard a sermon by the Rev. J. J. Goep. The service is generally conducted in French, but to-day it was in German. We were somewhat amused to find pasted on the church-walls a list of the texts to be treated by the preachers on each Sunday of the current year; a practice very different from the Scottish, where the subject of discourse is in general kept in a kind of mysterious secrecy, till announced from the pulpit at the moment of beginning the sermon. After the service, the sacrament of the supper was dispensed to members of the church, who advanced one by one to the altar, the females first. Mr Goep administered the bread, which was formed into pieces resembling wafers. M. Boissard, the other pastor, presented the chalice. The organ meanwhile sounded slow and solemn music, so soft as not to drown the voices of the clergymen, who continued at short intervals to repeat passages of Holy Writ connected with the sacred institution. A golden crucifix stood in front of the clerk's desk; but no perceptible notice was at any time taken of it, either by the officiating ministers or by the congregation.

In walking home we noticed that shops of almost every kind were open; and at the Innocents, all the covered fruit-stalls were well frequented. The coffee-houses were

full; and the piazzas of the Palais Royal, through which we passed in our way to Rue Vivienne, were particularly crowded. The rain had prevented the accustomed excursions of one class of the inhabitants to the public gardens of Beaujon, Marboeuf, Tivoli or Frescati, and of another class to the numerous guinguettes in the environs of the capital; and the Parisians thus made amends for their disappointment. The boué of Paris was this day very offensive, and foot-passengers were in continual hazard of being bespattered by reason of carriages incessantly passing from one side to the other of the overflowing central gutter.—All the minor theatres, we are told, will be crowded to-night. What a contrast with Edinburgh! It is almost impossible for a Scotsman to recognize the Day of Rest at Paris.

Monumens Français.

Sept. 29.—According to a previous arrangement, we this morning proceeded to view the French monuments collected together in the great monastery of the Augustins and its chapel, situate in Rue des Petits Augustins, Fauxbourg St Germain. The monuments have been derived from churches and religious houses in every part of France, which had been suppressed in the levelling and revolutionary period before the rise of Buonaparte. They are in general classed according to their age, and very neatly displayed; their erection here having occupied, for several years, the whole attention of M. Le Noir, a person of distinguished taste. The first objects are ancient altars of the Gauls, leading back the mind to the age which preceded the introduction of Christianity into France. Then appeared the tombs of Clovis and of Charlemagne. Amidst the sculpture of the early ages is introduced, by way of contrast, the statue of Corneille, and some other excellent specimens of modern art. Separate halls for the 13th and

five following centuries succeed. The 17th is extremely rich; the monuments of almost all the great men and geniuses of the reign of Louis XIV. being here assembled, from the monarch himself down to Le Nôtre his gardener; the Gothic mausoleum of the King having been transported from the cathedral of St Denis, and the tomb of Le Nôtre from the church of St Roch in Rue St Honoré. The monastic garden of this place has become a select cemetery for the men of genius of former times; the ashes of Des Cartes, Moliere, Masillon, and many others, now resting here. The mausoleum of Abelard and Eloise adds considerable interest to this scene*.

Garden of Mouceaux.

Having procured a fiacre, we drove to Mouceaux, once a splendid English garden, or rather *jardin fantastique*, belonging to the Duke of Orleans, and originally laid out, in 1784, by Mr Blaikie, as formerly mentioned. It is situate at the extremity of the Fauxbourg du Roule. It was much injured by fêtes being given in it, during the time of the Revolution; but although now comparatively in a state of disrepair, it is still a fine place. It receives a warm panegyric from Delille in "Les Jardins:"

" J'en atteste, O Mouceaux, tes jardins toujours verts,
Là des arbres absens les tiges imitées,
Les magiques berceaux, les grottes enchantées,
Tout vous charme à la fois."

* On going again to the Convent of Augustins in August 1821, I found that nearly the whole monuments had been removed, the present Government having ordered the restitution of such as might be claimed by the different churches and towns to which they originally belonged. The superb tombs of Louis XII. and XIV. had been sent back to St Denis; and the mausoleum of Abelard and Eloïse had been transferred to the new and truly picturesque cemetery of Pere La Chaise.— N.

It has lost, to some extent, the characteristics of the English style bestowed on it by Blaikie; but the serpentine walks, the clumps of evergreens, the rock-work, and the English-looking hot-houses still remain. The gardener seeming cautious and dry in his answers, we made our visit a short one.

Garden of M. Boursault.

We next drove to Rue Blanche, No. 20, and saw the tasteful villa and garden of M. Boursault. This gentleman, we understand, made his fortune by contracting for the cleaning of the streets of Paris; and what was gained by commendable industry, he now enjoys not only in a pleasing and rational way, but with all the correct taste which might be expected in the cultivated mind of a peer, but which does not always accompany nobility. The boundaries are rather circumscribed; but the lawn, the *allées*, the terraces, the grove, are all well proportioned, and well arranged, so as to give the appearance of space where it is wanted, and to disguise or hide objects which should not be seen. In short, M. Boursault has, in this spot, practically illustrated the excellent precepts of the English bard:

“ Let not each beauty every where be spied,
Where half the skill is decently to hide:
He gains all points who pleasingly confounds,
Surprizes, varies, and conceals his bounds.”

Some of the large trees, particularly a weeping-willow on the lawn near the house, are admirable specimens; and the groves and borders contain many rare foreign species of shrubs, which at once attract and delight the botanical eye. A very large *Andromeda arborea* may be mentioned as worthy of notice; and likewise a *Hydrangea quercifolia*, of uncommon vigour.

On one side of the grounds, and concealed from the view of those walking in the principal garden, is a large conservatory, which we all agreed in pronouncing to be well adapted for the culture of plants, and which we found to be richly stored with exotic rarities. We were here gratified with beholding a healthy *Araucaria excelsa*, fifteen feet high. There is likewise a plant of this rare pine formed from a cutting; but, though six or seven feet high, it still retains all the characters of a branch, without giving any indication of forming a leading shoot. A plant of the *Camellia Sesanqua*, which is still rare at London, but had been procured from thence by the zeal of M. Boursault, has attained a large size, growing in a very lax and dependent manner, and making very long shoots. We could not help remarking, that many of M. Boursault's rarest and finest plants had been imported from the English capital. The red sweet-scented China-rose (or Knight's animated, which is distinct from the blush sweet-scented), was still covered with flowers. *Ekebergia capensis*, *Bouvardia triphylla*, and many other rare plants, were growing well. *Citrus aurantium trifoliata* was now in fruit. *Epacris grandiflora* is here propagated by layers; and we remarked, that the gardener had been very successful in striking the *Ardisia crenulata* from cuttings. A double-flowered white oleander was still in beauty, and seems to be a variety of the *Nerium* not known at Edinburgh. *Astragalus longiflorus* had been in flower.

The stoves or bark hot-houses are on the opposite side of the garden, and very extensive. They, too, are well furnished with rare tropical plants. *Strelitzia parvifolia* had been beautiful. *Cyperus Papyrus* was still in flower, and *Gloriosa superba* likewise shewed its blossoms. *Globba nutans* made an elegant appearance, and *Plumcria ob-*

tusa filled the stove with its fragrance. Among the rarest plants may be mentioned *Bauhinia racemosa*, *Zamia pungens*, and *Arum grandiflorum*. There is a fine specimen of *Myrtus Pimento*; and *Mespilus Japonica* is cultivated in one of the stoves, and trained against the wall, for the sake of its fruit, called the Loquat. In a small reservoir here, several pretty little tortoises, from Isle of France, are kept: they are quite lively, constantly enjoying a temperature equal to that of their native island*. There is likewise a diminutive pond in one of the hot-houses, abounding with gold and silver fishes; and at one end of the range, a small aviary for the singing birds of warm climates is formed.

A pine-apple pit seemed to be well managed; the young plants being healthy and clean, and the older plants shewing fruit of considerable size. Poudrette, we understand, enters into the compost here employed for the ananas. Among the plants appeared a variety which was rather new to us; the fruit very long, being fifteen pips high, but narrow. This is the first instance we have met with, of the pine-apple being cultivated with due care and proportional success, in the neighbourhood of Paris; and we believe it forms the most favourable example of this branch of culture near the French capital. The demand for this luscious fruit is not such as to excite the industry of the market-gardeners; even the noblesse contenting themselves with such fruits as can be procured without the aid of glass. In some of the principal Parisian fruit-shops, however, a few flower-pots containing fruiting ananas may generally be seen; but the fruit is small, and there must evidently be many chances against its possessing the flavour of matu-

* Two of the same species may be seen in the hot-house of the Botanic Garden at Glasgow.

rity at the moment when it is wanted. The expence of erecting low glazed houses or pine-apple pits, with flues, and the difficulty of keeping up a regular fire-heat where coal is little known, are circumstances which probably deter many from attempting the cultivation of the ananas. But Mr Muirhead, gardener to Colonel Belsches of Invermay, and Mr Macnaughton, gardener to Colonel Wauchope of Edmonstone, have shewn, by their practice, that fire-heat is not indispensable: they form large hot-beds, composed wholly of leaves gathered from the woods in the end of autumn; place on them common glazed frames, of the largest dimensions; by means of adding exterior linings of leaves, or of making openings into the mass, the temperature is increased or diminished as wished; and in this way the plants are not only kept over winter, but produce large and ripe fruit, generally in the second year.

In front of the principal hot-house, six fine orange-trees are planted *en pleine terre*, and produce a pleasing effect. During the winter season they are covered with glazed frames, which are supported by the hot-house behind. The borders contain many of the best hardy perennial flowers. Most of these are accompanied by Sevre porcelain tallies, having the name of the plant painted on them; but though the tallies are neat, they unavoidably give a formal appearance to the borders, and impress one with the idea of a botanic school.

Mr Boursault himself joined us in the garden, and pointed out whatever he reckoned curious or rare. Upon our mentioning the object of our journey, he expressed his readiness to forward the views of the Society in any way that might be in his power.

We felt considerably gratified with the view of this villa and garden. The plants of every kind seem to be managed

in a judicious and careful manner, and the state of the whole does great credit to M. Daride the gardener.

We were already obliged to think of leaving this interesting capital, and therefore paid a visit to Lafitte's bank, Rue Mont Blanc. Such is the resort of English people to Paris, that an appropriate office has here been established for conducting their money-business, furnished with English clerks. An album containing the address in Paris of those who keep accounts with Lafitte, lies in the office, and frequently affords an opportunity to new comers of discovering the residences of their friends.

Paris Fruit in September.

Having learned that the English ambassador was this day to give a grand dinner to the Corps Diplomatique, and that the best fruit which the Paris market could supply would appear in the dessert, we called at the hotel in Rue Fauxbourg St Honoré, when Mr Wood, the intendant of the household, most readily displayed the fruit provided for the occasion. The melons were the Canteloup noir des Carmes and Melon de Malte; but of the quality of these we could not judge. The peaches were certainly excellent: they consisted chiefly of the Teton de Venus, the late Admirable, the Chevreuse, and the Maltese, the last mentioned being accounted at this season the sweetest. The nectarines were also of fine quality, particularly the Brugnion musqué and Grosse Violette. The plums consisted only of the St Catherine and the late Damask (damas de Septembre or prune de vacance). The pears seemed confined to the red and autumn Bergamot, and Grey Beurré. The grapes disappointed us; being deficient both in the size of the bunches and ripeness of the berries. They consisted chief-

ly of the Chasselas de Fontainebleau, the musk Chasselas, red Chasselas, and white Corinth. There were no pine-apples; when these are wanted, they are generally procured from Covent-Garden Market, by means of the Government messengers who are constantly passing between the two capitals.

The time set apart for our continental excursion had now more than elapsed, and our presence was required at home. We therefore made preparations for our immediate return, leaving unvisited, with no slight reluctance, several places at Paris highly deserving of the attention of the horticulturist. We allude, in particular, to the nursery-garden of M. Noisette, and to the royal nurseries of the Luxembourg and the Roule.

Having subsequently, in August 1821, had an opportunity of viewing these establishments, I shall here, with the approbation of my fellow-travellers, introduce some account of them, extracted from the notes which I took at that time.

P. N.

Noisette's Nurseries.

1821, Aug. 17.—I spent the greater part of this day in the celebrated pepiniere of L. Noisette, No. 51. Fauxbourg St Jacques, near the National Observatory. I was fortunate in finding M. Noisette at home; and on learning my name and pursuits, he immediately proposed to conduct me personally through his grounds, and he did so with the greatest attention. He has here formed an extensive arrangement of all fruit-trees adapted to the climate of this part of France. The genera and species are kept distinct, after the Jussieuan method; and the varieties of each species

are arranged in the order of the maturity of their fruit, after the mode of Duhamel. Of every kind he has a specimen-tree in a bearing state; and close by this specimen-tree are placed, in general, several young trees of the same kind, budded or grafted from the bearing tree,—or else stocks ready to receive such buds or grafts. Of the apple and pear species, most of the specimen-trees are trained *en quenouille*; so that, though numerous, and though now twelve years old, they do not require a very large space of ground. The plums, apricots, and cherries, are also so trained as not to occupy much room. Doubtless, trees thus confined to very circumscribed limits, cannot be expected to afford much fruit; but they yield enough to identify the kinds, and to satisfy purchasers regarding the precise varieties which they may wish to possess. If the slightest attention be here paid by the workmen, it is scarcely possible that a mistake should be committed as to kinds; stocks being, as already remarked, placed beside and around each bearing tree, to be budded or grafted from it at the proper season. No doubt, when there happens to be little demand, such budded or grafted young trees must occasionally be removed, and form nursery-lines in a separate compartment; and then accuracy will depend only on the correctness of the tallies, as in our British nurseries. But still M. Noisette has enjoyed the previous advantage of knowing with certainty from what kinds of trees he has derived the buds and grafts, and that they have been taken from trees arrived at a bearing state. In most of our British nurseries there is no collection of bearing-trees; and, of course, buds and grafts must either be taken from the young trees in the nursery-lines, or they must be procured from neighbouring gardens. If the former plan be resorted to, the young trees produced are generally regarded as likely to reach more slowly the state of bearing, and to continue,

for some years, less productive of fruit, than if the grafts had been taken from mature trees : if the latter plan be adopted, the risk of serious blunders must evidently be incurred. In no part of Britain, perhaps, do better nurseries exist than at Edinburgh ; but such an arrangement of bearing trees is still a desideratum there. The great space of ground that would thus be occupied, is almost the only objection that I recollect to have heard offered. But if the Edinburgh nurserymen would take a view of this department of M. Noisette's establishment, and remark in how small a space such a collection might be formed, I am persuaded that the want would be speedily supplied ; and it has been seen, that the quarter thus dedicated to bearing-trees is not wholly lost even as nursery ground. It must, I believe, be admitted that pyramidal trees are not very durable or long-lived ; but to make up for this, they possess the advantage of coming quickly into bearing.

The principal part of the arrangement is necessarily occupied with those kinds of fruit-trees which are generally cultivated and frequently in demand ; apples, pears, plums, apricots, peaches, and cherries. It is only in the greater variety of fine pears and peaches, that this French nursery excels our English ones. Figs, mulberries, vines, almonds, walnuts, chesnuts, quinces, medlars, azeroles, are not wanting ; but they occupy a subordinate station in the pomarium.

Apples.—The stocks employed are either the Paradise or the Doucin. Both of these are original dwarfish varieties of the apple-tree : the paradise has the greatest dwarfing effect, and produces the handsomest *buisson* and *quenouille* trees ; the doucin stock is preferred for *contre-espallier* and for half-standard trees. These paradise and doucin stocks are multiplied by layers and offsets only : if the seed of either be sown, the stocks thus produced, in rich

nursery soil, lose the dwarfish character to a considerable extent. Among summer apples, M. Noisette gives the preference to the Summer Calville, and for an autumn apple he strongly recommends the Reinette d'Angleterre or English Rennet. For winter fruit, the Common Rennet, or Reinette franche, he regards as incomparably the best, and he sells ten trees of it perhaps for one of most other kinds. The Canadian, the Golden, and the Grey Rennets are all much esteemed by M. Noisette as *couteau* apples; but the White Spanish, which was new to me, seems his particular favourite. It is a long cylindrical-shaped apple, having a delicate skin, marked with a fine bloom or farina. It is certainly not much known in the gardens around Paris, for I have not met with it any where else. M. Noisette considers it as one of the best, and it is doubtless one of the most ornamental apples for the dessert in the winter and early spring months, for it keeps till March. It is grafted on paradise-stocks, and might, in Scotland, be placed with propriety against a west wall. Another rennet, called the De Caux, M. Noisette likewise particularly mentioned, and recommended as a novelty worthy of the attention of the Horticultural Society. The fruit is very large and beautiful, and is in perfection for the table in February or March. A single apple will sometimes weigh more than an English pound. The tree, at the same time, is accounted productive; and being of strong growth, Noisette recommends it for orchards. In Scotland, it might occupy a sheltered station in the kitchen-garden. It does better on the doucin than on the paradise stock. The Reinette de Runeville is also highly praised. The White Calville is, I find, greatly preferred to the Red. The Pomme d'Api is prized more highly than I should have expected: it is generally grafted on paradise-stocks, and on these stocks the fruit is best. Small trees of it are

often planted in flower-pots; in which state they produce their fruit freely, forming very ornamental objects. Many hundreds of small trees adapted for this purpose are yearly sent from Orleans to the Paris nurseries. The different varieties of Fennel-apples, the golden, the common yellow, and the grey, are, I find, equally favourites in France as in Italy.

Among summer pears, the Epargne or Grosse Cuisse-Madame, being our large or improved jargonelle, holds the first place. It is ripe a week or a fortnight earlier than the common cuisse-madame, which resembles it, and which, in our older gardens, is often found under the name of jargonelle. M. Noisette recommends strongly, as a summer pear, the Rousselet de Rheims: this is a small roundish or oval pear, at present of a dark green colour, but acquiring a tinge of red as it approaches maturity: At Rheims these rousselets are much used for drying in ovens, making what are called *poires tapées*. M. Noisette made me taste the Bourdon musqué, a small round pear, very juicy and highly perfumed: it must be a very early kind, for the fruit is already rather over-ripe. He likewise made me try the Poire d'oeuf, an oval pear of considerable merit, and now nearly ripe. Among the autumn kinds, the Crasanne is accounted decidedly the best: A subvariety here cultivated, with finely variegated leaves, might prove ornamental in some situations at home. The Doyenné gris ranks next to the crasanne, being here more highly esteemed, and more generally cultivated than with us: the tree is considered as extremely fruitful, and as coming quickly *en rapport*, or into a fruit-bearing state. The Beurré gris and Beurré d'Angleterre are kept as distinct kinds, and are both strongly recommended: the sort called the English Beurré seems only a subvariety; the

fruit being generally smaller and of a more lengthened form, but possessing otherwise all the qualities of the grey beurré. The Messire Jean, and the Calebasse, are likewise regarded as fine autumn pears.—Of winter fruit, the St Germain is considered as indisputably entitled to the preference. Next to it, Noisette recommends the Passe Colmar (which has already been repeatedly noticed, pp. 31. 334.), and the Beurre d'Aremberg (which has also been already mentioned, p. 321.) The Winter Bonchretien and the Martin-sec, he likewise warmly praises; as well, as the common Colmar and the Virgouleuse. The Sylvange, which is quite unknown at Edinburgh, has also become a favourite with M. Noisette. I may remark, that the Winter Beurré, though excellent, seems to be little known and little in demand at Paris. The Chaumontel, too, does not here bear the high character which I expected; the fruit being represented as frequently gritty. I strongly suspect, that the management of this fine pear is much better understood in Jersey than at Paris. The picked specimens sent from thence to London in winter, with the fruit-stalks tipped with sealing-wax, are often from 10 to 15 oz. in weight, and quite free from grittiness.

The collection of *peaches* is very good. The Grosse Mignonne is here preferred to all others: the Belle Bauce, a large and fine-flavoured peach, regarded as a subvariety of it, is unknown at Edinburgh, and I hope the Society may be the means of introducing it to our peach-houses. The Petite Mignonne, the Early Purple, and the Chevreuse hative, are the early sorts most in esteem, these fruits possessing both juiciness and flavour; while the red and the white Avant-peaches, or nutmegs, which ripen in the beginning of July, have no other recommendation but their precocity. The Admirable is here accounted an excellent peach: the French

Royal of Noisette is evidently a subvariety of it; but his Belle de Vitry (noticed p. 448.) is distinct from it. M. Noisette remarked, that in the Admirable, when ripe, the skin readily separates from the pulp, while in the Belle de Vitry it adheres: but Mr Blaikie, I find, considers this as depending merely on the soil in which the trees grow. The Belle de Vitry is probably our Late Admirable? Our Yellow Admirable is here called *Pêche abricotée*. The Teton de Venus is regarded as one of the best of the late peaches, but the tree is not considered a very free bearer. The Chevreuse tardive is esteemed a good peach, and M. Noisette considers the tree as the most productive of all. He pointed out as a novelty, a nectarine, which he had picked up in Flanders several years ago, and which is known by the name of *Pêche lisse Desprez*. The fruit is small, but of good quality; and it is the earliest of all the nectarines, ripening at the middle of August.

While examining the peaches, M. Noisette shewed me several examples of different modes of training peach-trees and grape-vines together, so as to procure to both the benefit of the same wall, and at the same time rendering them productive of fruit; and he seemed to think that this mode of training might be found useful in economising the limited space included in our vineries and peach-houses in Britain.—Against one piece of low wall, a number of small peach trees, placed about five feet from each other, are all trained obliquely in one direction, at an inclination of 45°. He mentioned, that peach-trees, three years grafted, and thus trained obliquely, yield some fruit in the first year after planting, and are in full fruit in the second year. If such a tree happen to die, its place can immediately be filled up, by merely allowing the branches of the neighbouring tree to extend themselves. The inclined position of the whole

branches he finds to check considerably the vigour of the wood growth, and promote fruitfulness, comparatively few gourmand shoots appearing.—Small plum-trees trained in this inclined way to a low wall, even with a northern aspect, were yielding fine fruit.—Mr. Noisette stated, that it is not uncommon at Paris, on a south wall 8 or 10 feet high, to have single shoots of the muscat of Alexandria vine trained at the top of the wall, over peach-trees; but he remarked, that the vine necessarily tends to shade the peaches, and deprive them of the free circulation of air.—He then shewed me another wall, the shelter and reflected heat of which were economised in a different way. Peach-trees are trained immediately next to the wall; and, in front of these, at the distance of three feet, is placed a small trellis or slight railing, to which vines are trained, somewhat in this form.

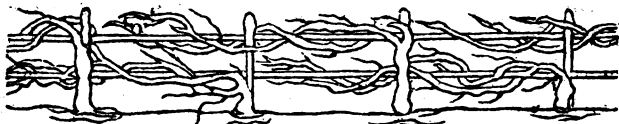

The vine-stocks are planted only three feet from each other: but as each plant is trained alternately to the upper and to the lower cross-rail, each shoot has of course an extension of six feet. In planting the vines, the roots are carefully directed outwards.—M. Noisette also shewed me a triple contre-espallier of vines; the outermost trained at the height of only 1 foot from the ground; the second, at 2 feet high; and the third, or inmost, at 3 feet from the ground. It is, I understand, a common remark of vigneron, that the nearer to the ground the bunches are produced, the richer is the flavour of the grapes. These low vines bore at this time very few bunches, but the plants were healthy. An evident objection, however, arises from this circumstance, that the roots of so many vine-plants

must speedily exhaust any border, and leave the peach-trees next to the wall, in a very poor soil indeed.

Among the *apricots*, the *Abricot-peche* (already noticed, p. 363.) seems to be in high estimation with M. Noisette, who indeed pronounced it to be the best; but he mentioned that the *Abricot commun* is most in demand. At Paris apricot-trees are generally treated as standards; they are often trained in a dwarfish form, and are then called *bretons* or *batardeaux*. The fruit of these is small, but of the highest flavour. The stocks chiefly used are suckers of the cherry-plum, or of the alberge-apricot.

As to *plums*, M. Noisette had no hesitation in announcing the *Reine Claude*, or *greengage*, as by far the finest known: But the *Jerusalem* is frequently in request, as well as the *Monsieur* and the *St Catherine*.

Among *cherries* he gives the palm to the *Cerise Royale* or *May-duke*; and he likewise praises highly the *Royal Cherry-duke*. The *Kentish cherry* seems here to be called *Courte queue de Montmorency*, or *Gros Gobet*; but the tree is regarded as comparatively a shy bearer. When a cherry-orchard is to be formed, M. Noisette decidedly recommends the planting of young stocks,—nursing these for a year or two in their place,—and then budding or grafting the best kinds of cherries upon them. This advice not being in favour of the trade, may surely be regarded as candid and impartial.—M. Noisette has several fine plants of the large-leaved cherry tree which formerly attracted our notice at the *Luxembourg*, (p. 416.) He mentioned that he had procured it from Poland, about 1806, and was told that the fruit was uncommonly large, bearing some proportion to the increased size of the leaves. I must remark, however, that this variety was known at the *Jardin des Plantes* in 1802, and appears in Mr *Blaikie's* list, made in that year*.

* Appendix, No. VIII.

Finding in a Dutch catalogue a kind of cherry, with the name of "Vier-in-pond," it was concluded that this was probably identical with the new acquisition, and the astounding appellation of "Cerise de quatre à la livre" was therefore bestowed. M. Noisette remarked, that our English name of "Tobacco-leaved cherry-tree," (a name, however, with which I had to confess myself unacquainted), was more appropriate; for that the fruit, which had, within the last two or three years, been afforded sparingly by some of the trees about Paris, had proved small, or at least not larger than common cherries. The leaves are very frequently a foot long, and half as much in breadth; and M. Noisette has occasionally measured some which had attained the gigantic size of a foot and a half in length. M. Noisette thinks it probable that when the trees shall have arrived at full age, the juices may come to be directed more to the fruit than to the foliage, and that cherries of considerable size may then appear. He is supported in this expectation, not only by the testimony of a Polish gentleman, who had seen very large fruit on old trees of this sort; but by this physical fact, that although the trees at Paris have hitherto blossomed freely, the fruit has very generally dropped off soon after forming, or at the time of stoning, indicating that the energies of the tree have hitherto been directed chiefly to the forming of wood.

The *Pacane walnut*, *Juglans olivæformis*, is kept in this nursery, being sometimes cultivated for its fruit; though not much attended to.

M. Noisette has been at pains to procure some of our good varieties of *gooseberry* from England, and his bushes now shewed some tolerable berries, although the best were past. But there exists a strong prejudice against this fine fruit, which prevents the Parisians from giving the improved kinds a fair trial: they have no idea that it is

possible that gooseberries should form an excellent article of the dessert; they think of them only as fit for making tarts, or sauce for mackrel!

The large-fruited amber *raspberry* appears here in great perfection, as well as the pale red or flesh-coloured. Both of these, I presume, M. Noisette has obtained from England; for they are not usually to be met with in the gardens about Paris.

I have already written so much about the pomarium, that the other parts of the establishment can only be glanced at.

The *roses* are disposed in groups or families, according to the general characters of their foliage and flowers, and the original species from which they are supposed to have been derived. M. Noisette has contrived to arrange no fewer than twenty-six groups, and to enumerate varieties to the amount of 600. Many of these, of course, have but slender claims to distinction. But he is constantly making experiments and raising new varieties from seed, and he collects from every quarter. A new rose of considerable beauty, allied to *Rosa Indica*, but with pale and sweet-scented flowers, has lately had the name of *Rose de Noisette* bestowed on it.

The collection of exotic herbaceous plants is considerable, and his general mode of culture seems to be good, for they are healthy and vigorous. Several sunk frames are destined to receive the greenhouse plants during winter; and the more tender plants are kept in a span-roofed hot-house, of uncommon construction, having various aspects. Noisette, however, is as far behind Cels in the botanical and floricultural department, as Cels is behind Noisette in the fruit-tree line.

Besides the nurseries which I have now described, and which extend to about ten acres (arpents), he has another, at some distance, of still larger dimensions, appropriated entirely to the raising of fruit and forest trees. In the Paris

nurseries, fruit-trees are kept from six to nine years under training,—a practice very different from that at Edinburgh; where they seldom remain more than three or four years in the nursery.

M. Noisette is about to publish “*Le Jardin Fruitier*,” in two thin volumes 4to, with a volume of coloured plates, representing the different fruits. Some of these plates I saw in his library. In point of execution they are inferior to those of Hooker or even of Bradshaw; but as M. Noisette has a most extensive practical knowledge of the fruits of France, the work will doubtless prove highly deserving of a place in the Horticultural Society’s collection. He mentioned to me that he is also engaged in a work on forest trees, both those for *alignement* (avenue and hedge-row trees), and for ornament (park and lawn trees and evergreens). He is to treat also of ornamental shrubs. It seems probable, however, that some years will elapse before this work be sent to press. I may add that M. Noisette, after having, with much care, studied the fruits of France for many years, expresses his high opinion of the general accuracy of the great work of Duhamel du Monceau. The execution of the engravings also is masterly. I would therefore strongly recommend to the Society to take the earliest convenient opportunity of furnishing their library with a complete copy of the splendid and expensive “*Traité des Arbres Fruitiers*” of that celebrated author. *

Luxembourg Nurseries.

1821, Aug. 20.—Accompanied by Mr Blaikie from St Germain, I spent the forenoon of this day in the Chartreux Nurseries. Louis XIV. was, I believe, the first distin-

* A. J. Marchant, Rue des Grands-Augustins, and Madame Huzard, Rue de l’Eperon, are the booksellers in Paris who have the best assortment of horticultural works.

gished patron of fruit-gardening in France, and to him the French owe this establishment. The religious brotherhood in this place, like the monks in our own country, had fine gardens, and paid much attention to the selection of their fruits. By investing them with immunities and privileges, the King encouraged them to extend their views, and to spend a considerable part of the revenues of their convent in collecting plants or grafts of all the best kinds of fruit-trees from every part of Europe to which their correspondence reached ; and the intercourse of the principal religious houses was in those days of the most extensive description. The Chartreux gardens are reported to have then included about eighty French acres, and in a few years a great part of these were converted into nursery-grounds. The fathers conducted matters prosperously, and for a long time continued to draw large profits from their nursery, while they greatly promoted the horticultural interests of France. It is understood that, besides importing all the known and approved varieties of fruit-trees, they likewise raised some good kinds from the seed. Among these is the Poire Sarassin, which is still familiarly known by the name of Blessed Pear, from the circumstance of its having been originally raised by these Carthusian monks.

At the time of the general suppression of convents in France in the year 1791, the Chartreux gardens were on the verge of destruction ; and the vast assemblage of all the kinds of fruit-trees, the labour of more than a century, would have been dispersed and lost, but for the zeal of old Hervy, the father of the present director. He contrived to preserve the kinds, and to retard the final demolition of the place. Fortunately, the enlightened Chaptal soon afterwards came into power, and, on the application of Hervy, secured the preservation of the remnant of the former collection, by procuring the designation of the ground as a

National Nursery for fruit-trees, and as a school for gratuitous instruction in horticulture. Under his patronage the collection was subsequently improved and increased. The Chartreux territory has evidently been much abridged, in the course of improvements which have been made on the gardens appropriated to the Luxembourg Palace; but still, inclosures of considerable extent, on both sides of the grand avenue leading from the Palace to the Observatory, are set apart as national nurseries. M. Louis Auguste Guillaume Bosc, Member of the Academy of Sciences, well known for his horticultural writings in the *Encyclopedie Methodique*, and as joint editor, along with Tessier, of the "*Annales d'Agriculture*," is Inspector or principal director. I was unfortunate in not finding him at this time, neither at his house, in Rue de Maçons, Sorbonne, nor at the nurseries. But M. Hervy, the resident and practical director, at once granted Mr Blaikie and me permission to examine the whole.

We first visited the general collection of mature fruit-trees, called *L'Ecole*, occupying a triangular space of between four and five acres, situate on the east side of the avenue, close by the director's house. The ground seems sunk many feet; but this is owing to the Luxembourg terrace having been elevated on the one side, and to the Rue d'Enfer having been gradually raised on the other. We remarked that the lower half of the boundary-wall next to this street is ancient, while the upper half is modern, and that the street is now on a level with the top of the old wall.

Grape-vines occupy a prominent part in this horticultural school, the kinds being very numerous, and the plants taking up a considerable proportion of the ground. Here are now assembled all the varieties of vine known to be cultivated in France, or, I may say, in Europe. To the best of my recollection, nearly 300 varieties are

named, and there are perhaps as many more without names, but which are regarded by M. Bosc as possessing characters sufficiently marked, to entitle them to rank as distinct. In the 66th volume of the "Journal de Physique," M. Bosc has given an account of the plan which he follows in classifying the varieties of the vine; and I understand he is engaged in a great work on this subject. The shoots, the leaves, and the bunches, are all to be figured of the natural size, and coloured after nature. The expence of such an undertaking must be such as to render it indispensable that it be regarded and cherished as a national work. In general, there is only one plant or stool of each variety; but the Chasselas de Fontainebleau is an exception, there being a long row of this on one side of the garden. It is the favourite variety, and has justly been styled the "raisin de table par excellence" of the French. At Fontainebleau the vines grow on a light sandy soil, and the grapes are sweeter than those produced on a heavy soil. It is even remarked, that plants brought from Fontainebleau continue for many years to yield more saccharine fruit. The varieties of table grapes are but few in number, perhaps scarcely exceeding twenty; the great mass of varieties consisting of sorts cultivated in the vignobles in the various departments of France, in Italy, Spain, and Germany. Many of these approach in character very near to each other; and it frequently happens, as with our orchard fruits, that the same variety is known under different names in different districts. The Bourdelet is a large grape which seldom ripens at Paris, but is much used for making verjuice. Like the verjus-grape formerly mentioned (p. 417.), it is said to be very good when ripe; and in warm seasons it sometimes acquires maturity.

Of *Fig-trees* there are eight kinds, and several of them now shewed fruit. There are three sorts of *Mulberries*,

the white (*Morus alba*), cultivated for feeding silk-worms; the rose-leaved, a variety of the former; and the black (*M. nigra*), cultivated for the sake of the fruit. Of *Almond-trees* there are not fewer than sixteen kinds here exemplified. The number of different *Apricots* is about twenty. The *Abricot Royale* was pointed out to us as a new and very promising variety, gained from the seed at this garden, about the year 1816. The fruit is as large as the *Abricot-peche*, and is represented as of superior quality, abounding with vinous juice, and possessing high flavour. It promises to ripen freely on standard-trees here, and may prove an important addition to our wall-fruit in Scotland. Of *Cherry-trees* the number of different kinds here arranged, seemed to me great: there are about fifty, and I am told fifteen more might be added; but, out of the whole number, not more than twenty are commonly cultivated. The trees are divided into *Merisiers* and *Guiniers*, originating from the *Prunus avium* or black guigne of our woods; *Bigarreaux-tiers*, originating from the *Prunus sylvestris*, or our red guigne; *Cerisiers* and *Griottiers*, from the *Prunus Cerasus* or common cherry. The *Belle de Choisy* was particularly praised; and also the *Montmorency*, which, it was intimated, was here restored or "perfectionnée," after having degenerated at *Montmorency* itself. The *Cerise de Nord* was now in fine fruit, and the tree seems very productive. I am persuaded that this is the variety which we sometimes saw at table in *Holland* and *Flanders* in the end of August 1817. Of *Plum-trees* about seventy kinds are cultivated. Two varieties of the green-gage are distinguished; the common *Reine-Claude* or *Verte-bonne*, and the petite *Reine Claude* or *Dauphine*, which last is frequently preferred. The *St Catherine* is much employed for stocks. Of *Apples* there may be about ninety varieties of table and baking kinds, and thirty sorts for cider or

chards. Among the rennets, the Golden Pippin and the Nonpareil seem both to be regarded as of English origin. Two varieties which have originated in this garden may be mentioned, but of their qualities I cannot speak; the Belle Hervy and the Concombre des Chartreux. Of table *Pears* the number is great, extending to 130 at least. Here our large jargonelle seems to bear four names,—Grosse cuisse Madame, Epargne, St Sampson, and Beau present: there appears no reason to doubt, therefore, that this was the pear recommended to us, under the latter name, in 1817, at Ghent (p. 46.), and at Brussels (p. 274). Our common jargonelle is probably their cuisse madame; and their jargonelle, a round red fruit, seems to be our Bellissime. In this collection appeared the Sylvange (noticed at p. 364.); it belongs to the bergamotte family. The Beurré blanc and Doyenné blanc, which we were led to regard as synonymous at Antwerp in 1817 (p. 105.), are here shewn to be distinct. A subvariety of the St Germain, with striped fruit, appeared, and was rather a novelty to me. The pear-trees are, in general, trained *en pyramide*, in order to save room; but a few are *en gobbelet*, or open in the centre. Many are placed on free-stocks, but some are on quinees; and these last seemed to yield the largest fruit, and they come soonest into bearing.

The *peach-trees* are trained to trellises placed against the inclosure-walls, especially where they have a western aspect. Including nectarines or *peches lissés*, the varieties exceed forty in number. Both male and female plants of the *plaqueminier* or American date-plum (*Diospyros Virginiana*) are likewise trained to the wall; and the latter was now in fruit. There is nothing very commendable in the appearance of any of the wall-trees.

In this "Ecole," during the spring and summer months, M. Hervy annually gives a course of lectures or demon-

strations relative to the culture, pruning and whole management of fruit-trees, including the vine. These demonstrations are frequently attended by several of the nobles of France, while the Chamber of Peers is sitting. Some of the Deputies, also, occasionally give their attendance. The number of regular students of horticulture from the provinces is not great; but the opportunities of instruction thus freely offered, must gradually tend to the spreading of information and improvement, and they certainly afford a trait of enlightened liberality worthy of the nation.

Leaving the "school" of fruit-trees, we crossed the grand avenue, and entered the proper nursery-grounds, which are situate on the west side of it. These presented a very large collection of young fruit-trees, especially peaches, plums, cherries and pears. The stocks in general seem small or weak; at least they are slender, compared with those employed in the Edinburgh nurseries: this was particularly the case with the plums and pears. The plum-stocks are chiefly suckers (drageons) from the cherry-plum, St. Julien, damask and jaret; but these are not reckoned so good as well-established seedling stocks. The cherry-plants, though also on weak stocks, looked well. When sold, a demi-franc (5d. Sterling) is charged for each; and all the other kinds are proportionally cheap. On passing a full grown specimen of *Prunus Mahaleb* or perfumed cherry-tree, we noticed that the ground below and around it, was covered with seedling plants, which had sprung spontaneously from the fruit shed by the large tree; and we now remarked that many hundreds of the young cherry-trees had been budded on mahaleb stocks thus procured. These stocks are of slow growth, but fit for budding in the third year; and cherry-trees placed on them are said to come sooner into bearing than those on wild-cherry stocks. Although, perhaps, a tri-

fling remark, it may be added, that the buds or ecussons are here tied with worsted threads.

Before leaving the nursery, I was assured, that, on making application to M. Bosc or M. Hervy, the Caledonian Horticultural Society would be supplied with such plants as they might at any time wish, precisely on the same terms as any similar institution in France; and it is to be hoped, that the Society will soon be in a situation to avail itself of this liberal disposition.

Roule Nurseries.

1821, Aug. 26.—In compliance with a kind invitation from M. Du Petit-Thouars, to breakfast with him, and taste of the fruits of his Nursery, Mr David Don and I this morning went to the Pepiniere du Roi, at No. 20. Fauxbourg du Rule, (i. e. Regulus).—Immediately connected with the house of the director is an inclosure called the Garden, containing somewhat more than an acre. The Nursery, which extends perhaps to five acres, is almost adjoining to the garden, being separated only by the lane called Rue de Courcelle. Mr Du Petit-Thouars received us with polite attention, and himself accompanied us through both inclosures.

In the garden there is an orangerie or greenhouse, and a tolerably good collection of plants, but nothing very uncommon or rare. Large specimens of *Grewia orientalis* were now in full flower, and set out in the open air; while with us this species is treated as a stove plant, and seldom produces its flowers. *Echium simplex* has generally been accounted a biennial plant, but it has here endured for eight years: the flowers, which are pure white, now appeared in large dense pyramidal panicles; the leaves are lanceolate, very entire, smooth and glaucous. Against different parts of the garden-wall are trained some of the more ten-

der kinds of trees. We remarked specimens of *Pistacia Terebinthus*, of both sexes, the female now shewing fruit. *P. Lentiscus* likewise here appears. The jujube-tree (*Rhamnus Zizyphus*) was in flower; but it seldom gives fruit so far to the northward as this: the jujubes sold in the Paris shops are from the south of France. The aspen-tree *Capparis spinosa*, when trained to the wall, and protected by a *paillasson* or straw-screen during winter, succeeds pretty well. The same may be said of the carob-tree or St John's-bread, *Ceratonia Siliqua*. The olive, however, is kept in a tub or pot, like the orange. The fruit of the bottle-gourd, *Cucurbita Lagenaria*, made, at this time, a fine appearance on the same wall. The squirting cucumber, *Momordica Elaterium*, was now ripe, and exploded upon being slightly touched. It springs up as a weed in this garden, and indeed has become naturalized in many waste places about Paris.

Our attention was directed to some espalier chasselas vines, in which it very evidently appeared, that the horizontal and depressed branches had produced many more bunches of grapes than those which were trained upright. This is a remark which may be turned to advantage in our vineries at home, especially where the vines are trained on arched trellises under the rafters, thus at the same time admitting sun-light to the branches trained to the back-wall; for, both on the arched trellises and on the back-wall, the horizontal and depressed inclination can easily be given.

In the nursery, M. Du Petit-Thouars seemed to attach great interest to a large peach-espalier, that is, a wall, perhaps 100 feet long, clothed with peach-trees. The wall has an eastern aspect, and is about 12 or 13 feet high: The trees, after having been cut over above the graft, have filled this space in seven years. The trees are between 50 and 60 in number, and have originally been planted very

close, sometimes within ten feet of each other. For a long time, this peach-espalier was managed according to the "taille de Montreuil," and a practised gardener from that village was yearly employed in the pruning. But for some years past it has exclusively been under the direction of Du Petit-Thouars, who has deviated, in some respects, from the Montreuil mode, and made various experiments on the trees, and particularly on the modes of training and pruning. Some of them have one upright stem, which however has no leading top, the leader having been trained horizontally to one side, and the next lower shoot to the opposite side: The principle acted upon is the common one, that fructification takes place only when the top of the tree, including the leader and principal branches, loses its verticality, or when the descending sap is obstructed in the canal which carries it towards the extremities. From the upright stem proceed four tiers of slightly inclined or nearly horizontal branches, each tier being about three feet distant from the other. Such horizontally trained trees are, I think, called *palmetiers*. Others have a very short stem, from which are trained two principal branches, slightly inclined from each other in the V form; and from these proceed similar horizontal branches, at regular distances on both sides. The principal branches of these trees had, when young, been pruned or disbudded according to the method recommended by M. Sieulle, immediately to be mentioned. Owing to the close planting, the horizontal branches of one tree are frequently intermixed with those of its neighbour on either side. The spaces between the tiers is filled up with small bearing branchlets and young shoots, trained to the wall somewhat in the fan way; and we doubt not, a certain proportion of these branchlets are yearly removed, and young shoots trained in their room. Several trees have their branches and annual shoots

unpruned, or laid in at full length, but every where bent: this bending or *arçure* having been strongly recommended by M. Cadet de Vaux, as calculated to supersede pruning. It is remarked, that if a *robber* be cut, an effort is made by the tree to produce another strong shoot; but if the *gourmand* be bent and retained in the curved position, the juices become fully elaborated, and flowers and fruit result, while no new attempt is made to send forth a strong shoot. All the branches of the trees on this peach-espalier are tied with rushes, either to nails or to the spars of the treillage. The wall is old and rough, and must be rather favourable to the lodging of noxious insects; and of this defect M. Du Petit-Thouars seemed abundantly aware. At this time, we must confess, all the trees, in whatever way trained or pruned, presented a fair crop of fruit. We may add, indeed, that the whole establishment seems to be well managed, and does credit equally to the Director and to M. Bonnet, the practical superintendant under him.

M. Du Petit-Thouars appears to be a strenuous advocate for the mode of training or pruning young peach-trees recommended, within these few years, by M. Sieulle. This person is fruit and kitchen gardener to the Duc de Praslin, and has under his management an excellent *potager* at Vaux-Praslin*. The distinguishing characteristics of Sieulle's method are applicable only to very young

* The Park of Vaux Praslin is particularly remarkable for this,—that it was the very first place planned and executed by Le Nôtre, before he had attracted the notice of his royal patron. We may here mention, that, for the last thirty years, the park and pleasure-grounds have been under the management of Mr Archibald Macmaster, a Scottish gardener, who was introduced into France by Mr Blaikie. Macmaster, feeling the advances of age, has recently resigned his charge, and retired (with a pension from his noble employer) to a small property of his own at Chessy, near Lagny,—still cherishing the warmest regard for Scotia, and delighted to hear of her prosperity and improvements.

peach-trees, in their first and second years. In the first year, he does not at all cut or shorten the two original or principal branches, called the *mere-branches*. The young tree has only to be fixed to the wall or trellis, requiring no other treatment till the fall of the leaf. By leaving these *mere-branches* at full length, and only disbudding late in the autumn, the vigour of the young tree is greatly promoted. He trains these principal branches to a much wider angle than the Montreuil gardeners,—perhaps 60° or 65° , instead of 45° . At the approach of winter he practises “*l'ebourgeoisement à sec*,” leaving only four buds on each branch, and removing the rest neatly with a sharp knife. At Montreuil, the *mere-branches* are cut-in or shortened in the first year, and disbudding is delayed till the leaves be developed in the following year. By disbudding at this season, the young tree not only suffers an unnecessary check or injury, but the consequence is that the buds left, instead of forming good shoots, develop themselves into numerous *brindilles*. Late in the autumn of the second year, Sieulle cuts-in, to the extent of one-third, the four lateral branches produced on each of his *mere-branches*. In the following year, he disbuds the lateral branches to the extent of one-half; and in the future management he practises winter disbudding greatly in place of pruning,—a practice long ago strongly recommended by Nicol in his horticultural writings. By Sieulle's method, M. Du Petit-Thouars remarks, the young tree is more quickly brought to fill its place on the *espalier*; it is afterwards much more easily kept in regular order: many fewer flower-buds are allowed to unfold themselves; but the necessity of thinning the fruit is thus in a great measure superseded, and the peaches produced are larger and finer.

It is well known that M. Du Petit-Thouars is an acute physiologist; and it may here be mentioned, that he has

particularly turned his attention to the structure of the buds of fruit-trees, and has drawn some conclusions considerably at variance with received opinions. He denies the propriety of the distinction usually made of wood-buds and flower-buds; but states, that, in the peach-tree, for example, each leaf produces a bud at its axilla or base; this bud soon becomes triple, the two outer proving flower-buds, and the middle one a leaf or wood bud. When this central bud happens to be favourably placed, it sometimes develops itself indefinitely, and produces the anomaly of a *gourmand* or robber. He has also announced, that the embryo flowers of peaches, apricots, pears and apples are palpably formed as early as midsummer of the year preceding that in which they are unfolded and produce fruit. He asserts, that the branches of a mature tree produce regularly every season an equal average quantity of embryo flower-buds; and that if these fail to be duly developed, it must be owing to the low temperature to which they are subsequently exposed, during the winter, or early in the following spring. If he be correct in these observations (and I am not aware of their having been controverted by any accurate observer), the affording protection to such fruit-trees, in the early spring months, acquires additional importance.

In the Nursery, there are a good many beds or lines of seedling forest-trees; considerable collections of young fruit-trees, budded or grafted; and a few of these, raised from seed. Some large trees deserve notice, as remarkably fine specimens of their respective kinds. *Fraxinus simplicifolia* (here called *monophylla*), which originated in England, has attained a large size. *Ulmus fulva* and *crenata* are handsome healthy trees. The Black Walnut of America, *Juglans nigra*, forms a lofty spreading tree. *Gleditschia triacanthos* is about 30 feet high; and the newly in-

produced species *G. sinensis* seems to stand well, and is likely to attain considerable size. An original specimen of *Sophora Japonica**, nearly forty years old, now forms a large tree, perhaps 45 feet in height, with a stem 3-feet in circumference. *Robinia viscosa* is about 40 feet high; *Quercus pyramidata* about 20.

We were previously acquainted with the clever little treatise of M. Du Petit-Thouars, which bears the quaint title of "Histoire d'un Morceau de Bois;" and were not surprised, therefore, to perceive on many trees marks of experiments on the circulation of the sap, shewing that the bark and the wood can alternately act as its conductor. In several young sycamore-trees (*Acer pseudo-platanus*), he had, in April or May last, removed, to the extent of two or three inches, the central wood and pith, leaving the tree to be supported only by four pillars of bark: in others, he had taken off, to a similar extent, the outer bark, liber and alburnum, leaving the trees to be supported solely by the central wood. In both cases, the trees were still living, but not making shoots so vigorous as those which remained untouched. In these instances of experiments on the sycamore, the wounded parts were left fully exposed to the air. Several other kinds of trees had died when so treated; but different species had survived, when plasters were applied, so as to exclude the action of the atmosphere, and form a temporary covered canal for the circulation of the juices. On a Bourdine peach-tree an experiment in ringing was now going on: a particular branch was deprived of a portion of its bark all around, and the incision appeared to have been carried fully down to the wood; at the same time means were employed to keep the branch

* An elegant weeping variety of this tree, hitherto unknown in Scotland, exists at Asnier, near the Bridge of Neuilly.

forward, or at some distance from the wall. The fruit on this ringed branch was abundant, but smaller than elsewhere; and it was here green, while in most other parts of the tree it was nearly ripe: the retardation, however, might to a certain extent be ascribed to the removing the branch beyond the influence of the reflected heat of the wall.

After having viewed the Garden and Nursery, we joined the Director and his family at their *dejeuné à la fourchette*. It was completely in the French style, and characteristic of the Director of the Roule Nurseries. Breakfast began with some slices of melon; then followed veal and mutton cutlets, a cold fowl, and a glass of wine; next came specimens of the produce of the fruit-trees which we had been viewing, peaches, nectarines, apricots, plums, all of excellent quality; and a cup of coffee closed the repast.

We afterwards adjourned to the library or study of M. Du Petit-Thouars. It contains a rich collection of French and Italian works on botany and horticulture, and very numerous packages of specimens of dried plants. He shewed us 84 unpublished figures and descriptions of orchideous plants, from Isle de France, Isle de Bourbon, and Madagascar. The plates have been etched with his own hand, and are adapted to the octavo size; but the letter-press is not yet completed. He proposes, we find, a new arrangement and new nomenclature for this curious and interesting family. We strongly urged him to hasten the publication of this work, so desirable to botanists and so important to his own fame. We fear that his sanguine disposition may induce him to undertake too much at once, and that there may thus be a risk of his leaving all unfinished. He presented me with some little *brochures* which he had issued, but which are not to be found in the booksellers' shops: among these was a syllabus of the lectures which he yearly delivers at the Roule Nurseries. Upon the whole, we both

felt highly gratified with our morning's entertainment. M. Aubert Du Petit-Thouars is a classical scholar, a gentleman of extensive general information, and an excellent botanist. He and his brother Aristide were sent in search of the unfortunate Peyrouse; but while they were still at the Cape of Good Hope on their outward voyage, they received the news of the dethronement and violent death of the King, and the progress of the revolutionary flame. They therefore confined themselves to excursions through the three southern isles of Africa, the botany of which they carefully examined. After the lapse of ten years, and after losing his brother, Aubert returned to Paris, when Buonaparte had effected the restoration of order and calm. But it is easy to see that he is, and always has been, a warm-hearted Bourbon royalist. He thinks boldly for himself on all subjects, whether political or physiological, and expresses freely what he thinks. It is natural, therefore, that he should have met with some opposition; and it would, perhaps, be too much to suppose that his opposers must be always in the wrong.

Paris Fruit-Market in August, compared with that of London.

Having, in 1821, visited Paris at a somewhat earlier season of the year than in 1817, it may not be amiss to subjoin a few notices regarding the state of the Paris fruit and vegetable market in the month of August, and to compare it generally with Covent Garden at the same period. The latter, however, I saw nearly a fortnight earlier, but under peculiar circumstances. The coronation of George the Fourth (19th July 1821) caused a glut of fruit in the London market, such as had never been remembered. Having reached London a few days after the coronation, I was still in time to see large quantities of the fruit, which had not

met with the expected demand. In regard to *pine-apples*, I was informed, that Mr Isaac Andrews of Lambeth alone cut sixty ripe fruit on the occasion, and that many hundreds, remarkable for size and flavour, came from distant parts of the country. One from Lord Cawdor's, weighed 10 lb.; and after being exhibited at a meeting of the London Horticultural Society, was sent to the Royal Banquet. *Pine-apples*, it has been already remarked, p. 457. are not to be got at Paris. From our possessing coals, and from our gardeners being well versed in the modes of raising fruit under glass, it is probable that we will always maintain a superiority in the production of this fruit.—The quantity of *ripe* grapes exhibited for sale in Covent Garden market from the middle to the end of July, would, if told, surpass the belief of Parisian cultivators; more especially when it is added, that the kinds were chiefly the *Black Hamburg*, the *white muscat of Alexandria*, and the *Frontignacs*. Andrews also took the lead in the grape department; insomuch that while very good *Black Hamburg* grapes, from different parts of the country, were selling, during the crowded state of the capital, at 4s. per lb., his bunches currently gave 6s. 6d. per lb. Their excellence consisted chiefly in the berries having been well thinned and thoroughly ripened. His vineries, I may add, are all heated by means of steam. On the 29th of July great quantities of grapes, remarkable for size and excellence, still remained in the market, and were selling at 3s. and 3s. 6d. a pound. At Paris *ripe* grapes are not to be procured, at this season of the year, for any sum. On the 14th August, Prince Leopold, then on his way to Italy, dined with the English Ambassador, when a splendid dessert was desirable; but ripe grapes could not be found at Paris. A price equal to 12s. Sterling per lb. was paid for some *unripe* bunches, merely to make a show, for they

were wholly unfit for table use. I may add, that on the 21st of the same month, the Duke of Wellington being expected to arrive to dinner, another search for ripe grapes was instituted throughout Paris, but in vain. In short, the English market is well supplied with fine grapes from the middle of June till the middle of November; but, from being raised under glass, they are necessarily high priced; while the Paris market offers a copious supply of the table Chasselas, from the middle of September to the middle of March, at very cheap rates,—from 12 to 20 sous, or 6d. to 8d. per pound; the coarse vineyard grapes being only 1d. a pound.—The bigarreau or grafted *cherry* was still very abundant in Covent Garden market, and also the black or Dutch guigne: at Paris, however, even the late cherries had almost ceased to appear in the market.—In the London market the only good *pear* was the large English Jargonelle (or epargne). The Windsor pear was on the stalls, but not ripe. The Green chisel (*hâiveau*), and the skinless (*poire sans peau*), were almost the only others I could see. The Paris market excelled, being well supplied with fine summer pears. The Ognolet or summer archduke, (which I believe is unknown at Edinburgh), was pretty common: it is named *ognolet*, from growing in clusters on the tree like bunches of onions. The large blanquet, and the long-stalked blanquet (the latter a very small fruit) were also common. The Epargne or grosse cuisse madame was plentiful. A fruit resembling it, called Poire des deux têtes, was likewise abundant: it was large, sweet, and juicy, quite ripe, but without much flavour. The Epine-rose, (Caillot or Cayeout), a very flat pear; the musk-orange, which is of a *yellow* colour only; the red orange, which has the true orange hue; and the Robine or Royal d'été, were all plentiful. The small early rousselet was exceedingly common and cheap, being produced abundantly

on old standards in all country-places. Towards the end of August, the Cassolette, a small pear of good flavour, and the Rousselet de Rheims, made their appearance; and the Poirè d'Angleterre (a beurré), began to be called through the streets in every quarter of the city.—*Apples* were more plentiful at London than at Paris. The Dutch Codlin and the Carlisle codlin were abundant; and the jenneting, the summer pearmain and the Hawthorndean, were not wanting. At Paris very few apples appeared. The summer Calville, a small conical dark-red fruit, and the pigeonnet, were the only kinds I remember to have seen.—*Plums*, on the contrary, were more plentiful and in greater variety at the Marché des Innocens than at Covent-Garden. At Paris, the Reine Claude, of excellent quality and quite ripe, was sold at the rate of two sous, or one penny, a dozen; while the same plum (green-gage) cost a penny each in London, though in an unripe state. The next in excellence at Paris was the Prune royale, of good size, and covered with the richest bloom. The Jaune-hâtive, the drap d'or, the mirabelle, the musk-damson or Malta plum, were common; likewise the Precoce de Tours, remarkable for its peculiar dark hue; and a deep violet-coloured plum called Prune noire de Montreuil. The Blue Perdrigon was just coming in. At Covent Garden the Primordian or jaune-hâtive, and the moroceo or early damask, were the only ripe plums to be seen.—*Apricots* were much more plentiful at the Innocens than at Covent-Garden. The common apricot, the Portugal and the Angoumois, which much resemble each other, were frequent; these were small, of brisk flavour: The Abricot-peche, however, not only excelled the others in size, but, in my opinion, in quality, holding that superiority among the Parisian apricots which the Moorpark does among the English; and it appeared in considerable abundance. At London only the Roman and Moorpark were

to be found, and the latter was not yet ripe.—In *pêches* the French market most decidedly surpassed the English. The quantity of this fruit presented for sale toward the middle of August appeared surprisingly great. It was chiefly from Montreuil, and in general in the most perfect state. Although ripe, scarcely a single fruit had suffered the slightest injury from the attacks of insects. This fact affords satisfactory proof that the plastered walls, being smooth and easily cleaned, are unfavourable to the breeding and lodging of such insects as often infest our rougher fruit-walls. The fine state of the fruit also shews the uncommon care which must be bestowed by the industrious inhabitants of Montreuil to prevent its receiving bruises in the gathering or carriage. The principal kinds in the market were the small mignonne; the large mignonne, with some of the excellent subvariety called Belle Baute; the yellow alberge; the Bellegarde or Gallande; the Malta or Italian peach; the red Madeleine, or De Courson; and the early purple. The peaches in Covent Garden, at the early period of the season at which I viewed it, were of course wholly produced under glass.—*Melons* appeared in great profusion at Paris. In the *Marché des Innocens* and *Marché St Honoré* the kinds were rather select, chiefly different varieties of Canteloup. These were not sold at so cheap a rate as I should have expected; ripe and well-flavoured canteloups costing 2, 3 or 4 francs each. But in almost every street the *marchands de melons* presented themselves; some occupying stalls; some moving about with *brouettes* or long wheel-barrows, and others with hampers on their backs, supported on *crochets*. In general those sold in the streets were much cheaper (perhaps not more than half the price of the others), but of coarse quality, such as would scarcely be thought fit for use in England. The fruit is frequently long kept; and in

the heats of August, the odour exhaled from the melon-stalls was sickening and offensive. The kinds were chiefly the following: the *Maraicher*, a large netted melon, so called from being cultivated in the marais or sale-gardens; the *Melon de Honfleur*, of great size, often weighing from 20 to 30 lb.; and the *Coulombier*, a coarse fruit, raised chiefly at the village of that name. These were almost the only sorts of melon sold in Paris, till our countryman *Blaikie*, about forty-five years ago, introduced the *Rock Canteloup* and *Early Romana*. I may notice, that melons of all kinds, even the best canteloups, are here raised in the open ground, with the aid of hand-glasses only, to protect the young plants in the early part of the season. In *Covent-Garden* market a great many small melons, chiefly of the green-fleshed and white-fleshed varieties, appeared; but they were uniformly high-priced, though not proportionally dearer than the *Parisian canteloups*, considering that they had all been raised on hot-beds under glass-frames.—*Mulberries* were much more plentiful at Paris than at London.—At Paris, fresh or recent *figs* were, at this time, very common and very cheap; it was, indeed, the height of the *fig-season*, and they daily arrived in great quantities from *Argenteuil*. The round white *fig* seems to be the only kind cultivated; at least it was the only kind that came to market. No fresh *figs* can be expected in *Covent-Garden* till the end of August, and then only small parcels. To make amends, the *London* market was supplied with fine *gooseberries* in profusion, while not one of good quality was to be seen at Paris. The same thing may be said of *raspberries* and *currants*, which are in a great measure neglected in France, or used only by confectioners. The *Parisians* have never seen these fruits in perfection, and it is therefore no wonder that, in the midst of a profuse supply of *peaches*, *reine claudes*, *figs*, and *pears*, they should

be overlooked.—New *walnuts* were already in the Paris market; probably about a month earlier than they can be expected at London. When speaking of these, Mr Blaikie mentioned, that the Baron de Tschoudi, near Metz in Lorraine, has introduced the practice of ringing his walnut-trees; taking out two inches of the outer-bark all around, and plastering over the part with the onguent de St Fiacre. The ringed trees not only prove more prolific, but the fruit is more early.—New *almonds*, of the kind called *Amande des dames*, appeared in Paris towards the end of August.

Paris Green-Market in August.

On the green-markets of the French capital few additional remarks occurred. Salsify was here extremely common; while little or none was observable at Covent-Garden. At the *Marché des Innocens*, I noticed a kind of pea with the legumens very much bent, and called the *Pois des Couches*: it was a *mange-tout*, or used without shelling, being destitute of the tough inner film. A small red radish, of an oval shape, was very common. Early red kidney potatoes were abundant, and at table they proved of good quality, but of the waxy kind. This early variety of the red kidney may be deserving the notice of the Society, and some tubers might easily be imported. Although the potatoes are red, the flowers of this variety are white, which is unusual.—Some plants are here occasionally used as salad-herbs, which are wholly overlooked in Scotland*. The leaves of *Basella rubra* and *alba* are used like spinach: The seed is sown in a hot-bed; the seedlings planted out in May, and trained against a wall or trellis, as we do love-apple plants. The green garden-orache (*Atriplex hortens-*

* At a restaurateur's, one day, the seedvessels of *Euphorbia Lathyris*, an acrid and insalubrious plant, were served in place of capers; but the more respectable green-grocers do not countenance such frauds.

sis) is very commonly cultivated, under the name of *irible* or *bonne-dame*; it also is used like spinach, but always mixed with sorrel. The leaves of white beet are often used, stewed and served with mutton or veal. The mid-ribs of the same plant, somewhat blanched, are employed under the name of Chards of beet: The blanching is accomplished by tying up the plants in the manner of endive.—Great quantities of water-cress (*Sisymbrium Nasturtium*) are constantly to be seen on the stalls, being much used both in salads and dressed like spinach or sorrel. The picked leaves are very generally served along with roasted fowl. The market is supplied partly from gardens in the neighbourhood of Paris, but chiefly from places at a considerable distance, where the culture of water-cress forms a distinct branch of industry. At the villages of Cailli, Long-Paon, and Fontaine sous Preaux, in Normandy, large plantations are formed, and are called *cressomieres*. I understand that it conduces greatly to the health and luxuriance of the plants, to have the water constantly circulating and flowing about them. The immediate neighbourhood of a small slow-flowing streamlet, therefore, where the water can be spread over the beds, forms the most desirable site. The beds are regularly weeded; and the whole are cleared out, and the cress-plants renewed, every second or third year. Water-cresses frequently appear in the Edinburgh market in the spring months; but they are gathered from ditches in the neighbourhood, and are not there an object of cultivation. The London market is now regularly supplied, throughout the year, like that of Paris, by persons occupied in the culture of the plant.—I may mention, that, upon inquiry, I found that blanched sea-cale shoots have never yet appeared in the Paris market; and in none of the market-gardens which I visited, did I see any preparations for the culture of this esculent. Whenever the blanched shoots of sea-

cale are once introduced at table, when their resemblance to asparagus is ascertained, and their excellence understood, they will soon form a favourite dish at Paris, particularly when forced in the winter and early spring months. The mode of cultivation practised in England, and the very simple means of forcing, are now made known to the Parisians, in the recent editions of the "Bon Jardinier," under the article *Chou marin*.

I may here remark, that even in the principal market-gardens of Paris, there is little or no *forcing* properly so called. Peas, haricots, and other legumes, are forwarded merely by sowing them on borders next to a south wall, with a gentle slope forward. Such borders are called *cottieres*, and their produce the *primeurs* of the season. Some few market-gardeners almost confine their attention to the production of primeurs; and the enhanced prices which they receive for asparagus, lettuce, new potatoes, and similar articles, amply reimburse them. Still they work only with sunk frames (*baches*) having hot-beds within them; and but to a small extent with these. They are thus, however, and by means of *couches sourdes* or common hot-beds, enabled to raise numerous seedling plants of the different kinds of excellent vegetables more early than others; and by planting these out in the borders, and carefully sheltering them during the cold weather of early spring; by means of *cloches des couches*, or straw screens and covers, they produce vegetables fit for the market several weeks before their neighbours. Some of the best of these primeur gardens are situated at the old quarries near Conflans, on the banks of the Seine, where the borders enjoy the reflected heat of the mural rocks.

I take this opportunity of mentioning, that a wheel-hoe (*ratissoire à roue*), somewhat similar to the one which we saw at Brussels (described at p. 297.), is in use in many of

the gardens near Paris, especially for cleaning the walks, which are generally laid with sand. A figure borrowed from Comte Lasteyrie* will give a much better idea of it than I could convey by description.

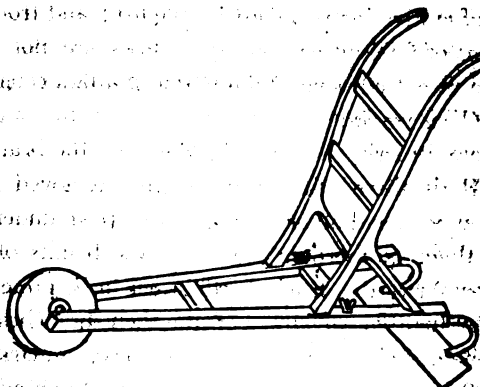

Paris to Rouen.

1817, Sept. 30.—At five in the morning we left Paris for Rouen, by what is called the high route. As we travelled by the diligence, we could, of course, see very little of the country. For several miles all the little eminences around were occupied by vignobles; but the vintage had nowhere commenced. In passing through the valley of Montmorency, we remarked a good many small cherry-orchards; and when these and the vine-plantations ceased, the margins of the road began to be lined by apple and pear trees, shewing that we had entered the country of cider and perry. In some places, large quantities of apples were lying, in heaps, on the road-side, ready to be carried to the mill: in other places we saw the gather-

* "Collection des Machines employés dans l'économie rurale," &c. published at the Lithographic Establishment of Count Lasteyrie, Rue de Bac, No. 58.

ers engaged in shaking down the fruit by means of long sticks. We passed some pretty extensive orchards: all the country roads and bye-lanes seemed fringed with fruit-trees, and every knoll was crowned with them. In one place we noticed a newly planted orchard; and from its appearance we ascertained, that the stocks are not only first planted in the field, but are allowed to attain considerable size and vigour before being grafted. In this way all the trees come to have tolerably high stems; the branches and fruit are thus to a considerable degree removed from the reach of cattle, and the plough can pass under the boughs, and lay the furrows close to the trunks of the trees. Those varieties, we may add, seem to be preferred, which have a natural tendency to send their branches upwards: indeed, we do not recollect to have remarked a single drooping tree. Many of the trees on the road-side are large, and evidently of considerable age. The soil seemed in general to be a light hazely loam. When the plowing is performed with the *charrue à versoir*, neither ridges nor furrows appear, but the whole has the aspect of having been delved with the spade.

We breakfasted at *Magny*, more than half way to Rouen. Here we noticed the swallows congregating previous to their annual migration. We were now in Normandy, and the chalk country soon commenced. Many of the garden-walls appeared to be constructed of clay, mixed with straw, and they had in general a coping of thatch. We saw several cottages constructed of the same material, intermixed with boards to strengthen it; but the walls of some of these had a coating of lime-plaster over the mud. Many rich pastures appeared, with large flocks of sheep inclosed in moveable folds; and we noticed that the sheep were sometimes folded on the plowed land, evidently with the view of improving it by

means of their droppings. In a small orchard, as we approached Rouen, we remarked several old fruit-trees which had recently undergone the process of *dechenillance*; that is, the paring off of the rough part of the outer bark, where insects are apt to lodge. We occasionally had a view of the banks of the Seine, which were every where beautiful, the day being fine, and the trees assuming their autumnal tints. The people in general had more of the appearance of poverty than we expected to have found among the Normans.

At Rouen we put up at the Hotel de l'Europe, in the Place de Neuf-marché, formerly Hotel Vatel, and now kept by M. Renaud.

ROUEN.

Oct. 1.—We could afford to dedicate only one day to this ancient capital of Normandy, and the weather again proved unpropitious. However, in a cold rainy morning, we visited the former Parliament House; the noble Cathedral, with its tombs and inscriptions recalling the memory of English sway in this country; and the Church of St Guen, a piece of the richest gothic architecture. We likewise went to Rue de la Pie, to see the house in which Corneille was born. Over the door is inscribed, "Ici né le 6 Juin 1606 Pierre Corneille." The foundations only of the original house now remain: the superstructure is at present occupied by a fireman.

Botanic Garden.

The day having cleared up a little, we were able to make an excursion to the botanic garden, on the banks of the Seine, opposite to the *ecole de natation*. It is of very limited extent; but the number of plants is considerable.

The general collection of hardy plants is arranged according to the Jussieuan method. There is a small pond for aquatics; with stone divisions around the margin, calculated to keep separate and to restrain the growth of the spreading kinds. The whole pond is surrounded by a low hedge of *Rosa indica*, even at this season covered with flowers, and producing a very lively effect. The hot-house is of clumsy construction, the roof being supported by huge oaken beams, and the astragals being nearly as thick as ordinary rafters. What a contrast with the light and airy fabrics of Mr Loudon at Bayswater! Mr Hay, who is not guilty of raising slight structures, could not help exclaiming, "Why, this is like ship-building." Some of the plants, however, were good, and deserving of a better habitation. *Ficus Bengalensis* or banyan-tree was about ten feet high, and very healthy: it now shewed its fruit, which we had never before seen. Dr A. L. Marquis, author of "*Fragmens de Philosophie Botanique*," is Professor of Botany. He gives lectures, during the summer half-year, from May to October, three times a-week, on Monday, Wednesday, and Saturday, from 6 to 7 P. M.; and herborizations, conducted partly by him and partly by M. Dubrueil, the chief gardener, take place every Tuesday. In the lecture-room is hung up a very large *carte botanique* (6 feet long by 4 in breadth), displaying at one view, Jussieu's method as edited by Ventenat. The exterior borders of the garden contain many excellent specimens of shrubs, some of them remarkable for the size which they have attained. Among these may be mentioned the snow-drop-tree, *Halesia tetraptera*; and the salt-tree, *Robinia halodendron*. *Celtis australis* has here reached the dimensions of a large tree. Upon inquiry, the gardener pointed out to us the original plant of *varin*,—the hybridous production between the common lilac, and an early-flowering

plant of the Persian lilac. It was raised from seed about thirty years ago, by M. Varin, then head-gardener: it was propagated by layers, and sent to Paris and Versailles, where it was called *Syringa Rothomagensis*. From thence it reached London, and, having been multiplied there, it is now found in almost all the gardens of Britain. The leaves are shaped like those of the common lilac, but are smaller; the branches are slender, like those of the Persian lilac; the bunches of flowers also resemble those of the Persian, but are larger, and of a darker hue. The original bush of varin has only once yielded prolific seeds, and there is a single seedling plant from it in the garden. The cut-leaved lilac is here regarded as a sub-variety of the varin; a plant with cut leaves having repeatedly yielded seeds from which true varin lilacs have sprung. A trifol leaved variety has also resulted from the sowings made here: this last is hitherto unknown in our Scottish gardens.

Vallet's Collection of Orange-Trees.

Crossing the Seine by the famed bridge of boats, we proceeded to Rue d'Elbœuf in the Faubourg St Sevre, and, at the sign of the pomegranate-tree, No. 23., entered the nursery-garden of M. Vallet. It was not without some feelings of surprise that we here beheld so magnificent an assemblage of orange-trees, that we pronounced it to be surpassed only by the royal collections. We cannot doubt that many of the large trees must have been bought up, at low prices, at the time of the general emigration of the noblesse of France. The orange-trees of large size are not fewer than eighty in number. Of these one venerable specimen is regarded by Vallet as above 400 years old; and there are several which must have seen at least two centuries. About 150 more are of such dimensions, that they

would be accounted large in Britain; and there are many others, of small size, but in a flowering state. M. Vallet makes a good deal of money by means of the blossoms, from which he distils orange-flower water: but we found that he was willing to part with the largest plants, if he could get a suitable price; and he mentioned that he had sent some very fine ones to England*. Certainly, any Englishman wishing for a fine collection of the Citrus tribe would do well to resort to Vallet's; the intercourse by sea being easy and direct. The citronier-poire was still in blossom; and we were told that this variety is scarcely ever without flowers. A few of the plants had been allowed to form some of their fruit, producing a pleasing effect. There is also a tolerable collection of double-flowered pomegranates and neriums, in small square boxes; and these appear to be sold very cheap. We entered a hot-house of the old construction, having the slated part of the roof projecting considerably over the front glass. This projection, Vallet himself condemned as unmeaning and hurtful; adding, that it could be of little use in warding off hail, for that the heavy hail-showers generally came from the south. The hot-house

* On revisiting Vallet's nursery in the beginning of August 1821, I found that he had, in the intervening years, disposed of a considerable number of his large specimens, and that most of these had also gone to England. Still, however, a rich collection remained.

I may here notice, that, since 1817, Calvert and Co. (Englishmen) have established a nursery at Bonne Nouvelle, near Rouen, in which they devote as much attention to the Rose tribe as Vallet does to the Orange. Their catalogue enumerates near 900 varieties of roses! Yet they possess very few of the "Scots roses," and Messrs Austins of Glasgow could furnish about 300 varieties of these alone. Without intending the slightest disparagement to the laudable zeal of florists and cultivators, we concur with those who think that it would be better not to have more than a tenth part of the number of roses, and that each variety should possess such marked and permanent characters as might render it easily recognised.—N.

contained few uncommon plants, being chiefly used for forcing rhododendrons, azaleas, roses, and other ornamental shrubs, in the winter months.

The environs of Rouen are well known to be both beautiful and fertile. Great quantities of fine pears are here produced; crasannes, chaumontelles, colmars, St Germain, and bonchretiens: of these last it is often literally true that

“ The branch here bends beneath the weighty pear.”

Considerable quantities of the pears are sent to the London market; and at Ducler, ten miles westward from Rouen, most of the Normandy rennets which go to England, are raised.

Heavy rain having again come on, we could not ascend the Hill of St Catherine, the view from which, in a fine day, is said to be delightful*.

Rouen to Dieppe.

Oct. 2.—To-day we proceeded to Dieppe. Fruit-trees continued, for a great part of the way, to line the road, and to form the divisions of the fields and pastures. They were chiefly apples; but some pear-trees appeared, and a few plums. In one place we had an opportunity of seeing people planting rape, on a field which had this year borne a corn crop. The ground is twice plowed: at the second plowing, a row of plants, at a foot distant from each other,

* In the beginning of August 1821, I had an opportunity of ascending the Hill of St Catherine on a clear day; and I would recommend doing so, to all who visit Rouen, the prospect being exceedingly rich and varied. The botanist may, in his walk, pick up several herbaceous plants not to be found in Britain: Among these are *Digitalis lutea*, *Sideritis scordiododes*, and *Linaria supina*. *Asperula cynanchica*, *Teucrium chamædryis*, and *Linaria repens*, are spread over the hill. Near the top, a Scotsman will not be displeased to remark two of his native heaths, *Calluna vulgaris* and *Erica cinerea*, with some bushes of furze or whins.—N.

is laid slantwise into the furrow, the earth turned over by the next furrow covering the roots. Although this is but a rough mode of planting, very few plants, we are told, fail to grow. The rape-seed will be ripe against next June, and cleared off in time for a second crop of some kind. Fields of lucern occasionally presented themselves.

Dieppe.

Oct. 3.—The morning was very cold, and we found all the little pools in the streets covered with a pellicle of ice. The schooner *Prince Regent*, Captain Bulbeck, being to sail in the afternoon, we had only a very short time to spend at Dieppe. We expected nothing, and we met with nothing interesting in the way of horticulture at a sea-port town. We ascended to the bomb-battery on the heights at the N. E. side of the town, and had a complete view of the harbour, so noted as the resort of privateers during the late war. The harbour is a tide one, very ill constructed, and having its entrance choked with gravel. It was now ebb-tide, and several hundred women with baskets were engaged in the hopeless task of clearing the channel, by removing the gravel from the one side of the bank to the other: a more inefficient remedy could scarcely be devised, as the next gale from the N. W. must inevitably restore the whole to its former state. In the fields near Dieppe, some oats and even barley still remained uncut; and a good deal of corn was lying cut on the stubble. We understand that it is a common practice to let it lie, unstacked, till it be wanted for thrashing.

About five in the afternoon, with the aid of about 150 of the gravel-carrying females, our schooner was hauled down the sinuous channel; and, after grounding once or twice, we were enabled to set sail for England.

Brighton.

Oct. 4.—Enjoying a fine breeze, in nine hours we anchored in Brighton roadstead. At day-light we got ashore, and went to the Old Ship Inn. After passing our luggage at the Custom-House, we spent the rest of the day in viewing this fishing-town or watering-place, which has been raised to celebrity by the circumstance of the Prince Regent frequently residing here. The Pavilion fell greatly short of our expectations; but we could judge only of its general appearance and its local situation; for, notwithstanding that the Prince was absent, we could not obtain access even to the pleasure-grounds, far less to the interior of the mansion. The natural scenery here seemed to us destitute of any striking feature; no steep rocks jutting out in the sea, and no extensive woods forming a back ground: the shore, at this time, appeared bare, tame, and monotonous, enlivened only by some mackrel-boats drawn up the gravelly beach, and by two or three pleasure-yachts at anchor, with their pendants displayed. But the Prince of Wales often evinced that he possessed good taste; and it seems probable that when he pitched on Brightelmstone, the aspect of the whole place was considerably different. The very attractions of royalty have, in the course of years, by promoting the increase of population and of buildings, deteriorated the general appearance; they have had the effect of injuring the Pavilion in particular, by depriving it of all the charms of a maritime situation: it has come to be surrounded by houses, and no longer enjoys even a glimpse of the sea. A square called the Steyne, situate near the Pavilion, contains many good houses, which are generally inhabited by families of the first rank.

Brighton to London.

Oct. 5.—Mr Hay here parted from us, taking the road to Portsmouth, with the intention of spending a day or two at Broadlands, near Rumsey*. Mr Macdonald and I set off for London. Furze hedges are rare in Scotland; but we noticed many in Sussex, and, though six or eight feet high, some of them were compact and efficient. Near Crawley we saw an English elm of great age and uncommon dimensions, the trunk being nearly 20 feet in circumference: it is much hollowed, and a door has been placed on the hollow, to prevent the interior from being injured by thoughtless persons.

LONDON.

We again spent a few days at the English capital, viewing some of the admirable horticultural establishments in its neighbourhood. Our notices of these must, however, be very brief.

Portman Nurseries, New Road.

Oct. 6.—To-day, Mr Macdonald and I spent some time in the nursery-gardens of Jenkins and Gwyther. The extent of glazed houses is very great. One of the houses abounds in the plants of New Holland, among which we remarked some fine specimens of *Melaleuca glauca*. No fewer than four houses are appropriated to the raising of ananas plants, which may here be purchased of every kind, and of any age required. If little demand for young plants happen to occur, they are in due time placed in a

* See Appendix, No. XI.

fruiting-house, and the produce is sent to market. This is a branch of the business with which a Parisian nurseryman has no acquaintance. An extensive botanical garden has here been established, under the direction of Mr Donald Monro*, who was educated under the late distinguished Mr George Don of Forfar. The plants are arranged according to the Linnean system, in seven parallel beds or borders, which pass around the whole extent of the garden, with two rows of plants in each bed. Each plant is accompanied by a tally, containing the name of the *genus*, and indicating in figures the *number* of the *species* in the garden catalogue. As a collection of hardy herbaceous plants, this bids fair to be second to none.—We next visited the fruit-tree nursery-lines. The young peach-trees were, in Mr Macdonald's opinion, better than most of those which he had seen at Vitry. The more common peaches are worked on mussel-plum stocks; the finer, such as the grosse mignonne, gallande, and Grimwood's Royal George, on what are called pear-plum stocks. Almond-stocks are very little resorted to.—On inquiry we were told, that one of the principal *stock-growers* (who supplies these as well as stocks for apples, pears, &c.) is Mr Donald at Working, near Guildford; and another, Mr Watraw, at Knaphill, near Ripley.

Oct. 7.—Mr Macdonald having gone to the seat of the Duchess of Buccleuch at Richmond, I spent the morning in *Covent-Garden Market*, a never-failing resource for amusement and instruction to the horticulturist. My ve-

* Now superintendant of the garden of the Horticultural Society of London.

nerable acquaintance Mr Dickson* showed me some Brown Beurré and Crasanne pears imported from France, much larger and finer than any we had seen at Paris or Rouen, and yet they had come from the neighbourhood of the last-mentioned city;—so true it is, that the best articles will always reach the market where the best prices are given. Some of the picked crasannes were to-day sold at no less than 14s. a dozen; while at Paris they would not have brought two francs a dozen.

This happening to be the day of the periodical meeting of the Council of the *Horticultural Society of London*, Mr Dickson obligingly proposed that I should accompany him to it. The meeting was held in the apartments of the Linnean Society in Gerrard Street, Soho †, at 1 o'clock. The business was conducted by Mr Joseph Sabine, the honorary secretary, in the most regular style, and in a manner well calculated to create and to foster an interest in horticultural pursuits. Specimens of uncommon varieties of several fine fruits were exhibited and tasted, and a free conversation on their respective merits was encouraged. Some members brought fruits and specimens of plants in their pockets, in order to acquire from the more experienced practical members a knowledge of their names and history. Tubers of a kind of potato which had been recommended, and offsets of a new strawberry which had formerly been approved

* Mr JAMES DICKSON, the distinguished cryptogamist, then in his 80th year, and now no more. He died, at his house at Croydon, in August 1822; and, feeling the ruling passion strong in death, was, by his own desire, buried in a romantic church-yard among the Surrey Hills, where, in his earlier days, he had been accustomed to gather rare mosses.—N.

† The Horticultural Society of London has since purchased a house in Waterloo Place, where they have fitted up convenient and even splendid apartments.—N.

of (Wilmot's scarlet), were presented to such members as wished to make trial of them, and to me as representing on this occasion the Scottish sister establishment. It was intimated, that seeds of the Valentia green-fleshed melon would be ready for distribution at next meeting. Mr Braddick, a distinguished amateur horticulturist, invited me to bring my fellow-travellers to view his garden at Thames-Ditton; and Mr Grange obligingly offered to shew us his extensive market-garden at Hoxton, near Kingsland.

The remainder of the day I spent in making short calls at the nurseries of *Messrs Colvills* in the *King's Road*, whose collection of exotics rivals that of *Cels*; at *Davy's*, in the immediate neighbourhood of the former, distinguished for excelling in what are termed florists' flowers; and at the *Apothecaries' Garden, Chelsea*, now under the able superintendence of Mr William Anderson.—But supervening indisposition prevented me from making any notes on these places.

Extracts from Mr HAR's Journal.

Oct. 9.—Having arrived from Hampshire yesterday, and finding Mr Neill had unluckily been taken ill, Mr Macdonald and I resolved to spend two or three days in visiting some of the many excellent gardens and nurseries around the metropolis.

We first went to *Lee and Kennedy's* at Hammersmith. The extent of glazed houses is here very great, and they contain a large assortment of plants of every description, and in excellent condition. They particularly excel in Cape heaths; in camellias, of which there are fifteen varieties; and in the finer geraniums. As a novelty may

be mentioned a double-flowered *Ulex Europæus* or furze-bush. These nurseries are so well known, and so celebrated, that it seems needless farther to enlarge regarding them.

We next visited the *Comtesse De Vande's garden* at Bayswater. It is a mere garden, without any dwelling-house, and affords a proof of the Countess's great attachment to plants. The excellence of the place depends entirely on its possessing a copious collection of stove and greenhouse rarities. It seemed rich in the *Convolvulaceæ*; and among these the *Convolvulus bryoniæfolius* and *Ipomœa Jalapa* were now in flower.

From thence we went to *Kensington Gardens*. The greenhouse here is a very large, old structure, and the collection it contains is extensive, but consists only of the more common sorts of greenhouse plants. There are some excellent houses for pine-apples and peaches. At this time workmen were employed in erecting a steam apparatus for heating the pine-stove, by conveying steam along copper-pipes in front of the house. The boiler connected with the pipes is also of copper. Although the peach-houses are good, yet the trees, which have been in them for several years, have not been successful. This has been attributed to a damp bottom; and, to remedy this fault, they were now busy cutting large drains, at considerable expence. This illustrates a too common error in erecting hot-houses, and laying out gardens. The natural level of the ground is taken, and, in making the borders, the sub-soil is cut out, and its place supplied with garden mould, in order to obtain a proper depth of suitable earth: whereas, if the level of the hot-house or fruit-border was raised a foot, or in some cases eighteen inches, above the natural soil, by merely laying good earth over it, this would frequently

prevent much unnecessary expence, and many serious disappointments, which are often discovered too late for amendment. There is also here a large mushroom-house, with shelves, on which there was at this time a great crop of fine mushrooms.

We then visited *Chiswick*, the seat of the Duke of Devonshire. There is here a magnificent suite of hot-houses, 308 feet in length, and said to have cost L. 15,000 Sterling. The conservatory is placed in the middle of the range, having a gilded dome, partly glazed, and forming a portion of the roof. In the centre of the conservatory there is a fountain and basin, with a few aquatic plants in it: the fountain is only permitted to play on particular occasions, as a supply of water can only be obtained by forcing it up from the Thames. Behind the conservatory is a small company room, furnished with chairs and sofas. The pineries front east and west, and are placed in connection with the range at each end, projecting northward over the gable of the sheds. The effect of the whole is certainly very grand; but more attention seems to have been paid to ornament than to the adaptation of the buildings to the principal object for which they are intended. Here we saw the American aloe, *Agave Americana*, in flower, the stem rising 30 feet high. There are eight very large cedars of Lebanon, on each side, in front of the palace; the trunk of one of them measured 18 feet 4 inches in circumference, and the tree appeared to be from 70 to 80 feet high. There are also some fine trees of the same kind, with very beautiful tops, on the north side of the mansion. In front of the hot-houses is a flower-garden, disposed with good taste; and in the pleasure-ground between the palace and the hot-houses, a jet d'eau, which we saw play for a few minutes. We had not an opportunity of seeing the kitchen garden.

We next proceeded to *Kew*, and Mr Ayton not being at hand, we saw Mr Thorburn, foreman of the Kitchen Garden. The pine-apples were extremely good. On the back flue of the stove, they were raising a considerable quantity of cucumbers in boxes and large flower-pots. They sometimes do very well in such situations; (at Archerfield I have cut them at Christmas); but great care is necessary to prevent the red spider from infesting them; for if this insect get upon them, the crop will completely fail. Where steam, however, is employed in a pine-stove, it will have considerable efficacy in preventing their depredations. We then looked into the Botanic Garden, where I found Mr Begbie, the foreman, an old acquaintance. The hot-houses are not placed in any regular form, but scattered over the garden. In one of them Mr Begbie drew our attention to a plant of the *Cactus cochinillifer*, which had been brought to Britain with the cochineal-insect feeding upon it. There was still a considerable number of the insect upon the plant. In another of the houses, he shewed us a new species of *passiflora*, having eatable fruit, (*Passiflora edulis*). The plant had fruit upon it at this time: it is of an oval shape, purple coloured, about the size of a small hen egg. It has sometimes been served up with the dessert at the Royal table.

It was by this time growing dark, and we went to Richmond and spent the night.

Oct. 10.—In the morning we proceeded to *Hampton Court*. There is here a considerable quantity of forcing. A steam apparatus for the pine-pits and stove, with copper pipes 6 inches square, and atmospheric valves in them to prevent compression, had just been finished, and put in use that day for the first time. The plants were very good.

The celebrated Black Hamburgh vine had a large crop upon it. It is now much extended since I saw it 85 years ago, and a new house has been erected over it.

We called on *Mr Wilmot*, a distinguished market-gardener at *Isleworth*, who has raised several new fruits and improved others. He uses steam for cultivating pine-apples, and also for forcing other fruits. He was unluckily much engaged at this time; and we were not able to make a second call.

We next went to *Spring-Grove*, the seat of Sir Joseph Banks, and saw Mr Oldacre, who very civilly shewed us every thing about the place. They have here newly erected a steam-apparatus, copper-boiler, and triangular copper-pipes. He drew our attention to the effect which heat, from steam, had produced upon an orange-house. The orange-trees had been in a declining state, but no sooner was steam-heat applied, than they sent forth new shoots. He had a great quantity of the true vegetable marrow gourd, and gave us some seeds of it. The pine-apples here were excellent. We saw Mr Oldacre's mushroom-house, the first of the kind in this country; but the beds were not, at this time, in a state of bearing. It was around the margin of a small pond, at Spring-Grove, that the large-fruited cranberry was first cultivated in this country; and in the same pond, the Canadian rice has become naturalized. On the lawn appear some of the first Rhododendrons and Kalmias that came to Britain.

At *Sion Hill* the pine-apples were equal to any we had yet seen. Mr Ross, the gardener, had received a considerable quantity from abroad, which were doing very well. The garden is plain, but the hot-houses are extensive. We got a few potato tubers from a publican at Brandford, who said they were the earliest in that quarter, and who makes money by them.

From this we proceeded to *Ditton Park*, the seat of Lord Montague; but it being late when we arrived, we saw nothing of the grounds that night.

Oct. 11.—Next morning we walked around the new garden at Ditton. The soil is very good: as an evidence of this, the young trees against the walls, though only of a few years standing, already reach to the top. The walls are only 11 feet high, which is too low where there is so good a soil, and particularly when trees are trained in the fan mode. There is a good greenhouse here, and a vinery having fixed sashes. In the park, there are some fine old oaks, and some shells of oaks, and English elms, of great dimensions. One decayed English elm measured 28 feet 3 inches in circumference, another 23 feet 9 inches in circumference; the remains of an oak 27 feet in circumference. A deciduous cypress was 7 feet in circumference, and equal to any we had seen in the Low Countries. Lord Montague, when he understood we intended going to Windsor, very obligingly gave us a letter of introduction to General Taylor, Secretary to his Majesty.

On going to *Windsor*, we saw General Taylor, who furnished us with a pass-key, and permitted us to walk over the grounds around the Castle at pleasure. We walked by the lower terrace, along a fine bank of trees, which has been much neglected. They were just thinning them out; it would have been much more in their favour, if this had been done sooner, and very gradually. Some beautiful views are obtained from this terrace. Thomson has not said too much in praise of "imperial Windsor."

From Windsor we went to *Frogmore*, a pleasant residence of Queen Charlotte. The hot-houses, however, did not command much attention. I got from the gardener a fruit of

Passiflora edulis, containing ripe seeds. This was the best plant of it we had seen; it had, perhaps, 100 fruit upon it. The pleasure grounds are very pretty, and well laid out, with a fine piece of water. There is here a rosary, and in connection with it, a small rustic building, and above the door this motto, "Here contemplation dwells." It is fitted up within in the style of a peasant's cottage. Upon the table there was a groupe of artificial fruit, and a book. I was very well pleased with every thing at Frogmore but the flower-garden, the kind of taste displayed in which was not in accordance with the rest of the place.

Oct. 13.—In the morning we went to The Vinery at Hammersmith, breakfasted with Mr Lee, and again walked over the Nurseries.

Called next upon Messrs Whitley, Brames and Milne, nurserymen, Fulham. They have a fine collection of dahlias, which were still in flower. Their store of greenhouse plants is rich; among these was the rare *Enkianthus quinqueflora* from China. This is upon the whole an excellent nursery, and very well kept.

We next visited the seat of the *Bishop of London* at Fulham. Nothing particular appeared in the kitchen garden, except that succory was planted out for a winter salad. In the ground around the house, some remarkably large specimens of fine trees, originally planted by Bishop Compton, attracted our notice, particularly an evergreen oak 10 feet in circumference, and a stone-pine 11 feet in circumference and 30 feet high. The gardener gave us specimens of the bark of a cork tree 8 feet 8 inches in circumference. The lawn in which these fine trees stand, is protected from cattle, by a wrought iron-rail, with cast-iron posts.

From Fulham we went to *Squire Rooker's* near *Wansworth*. This is a neat place, with a very good kitchen garden, and excellent hot-houses for forcing grapes and peaches, but they are rather too high in front for pine-apple culture. There is a neat conservatory in the pleasure-ground near the house.

Oct. 14.—We went this morning to *New Cross*, and inspected the nursery-grounds of Messrs Cormack and Son. We there found a good collection of greenhouse and American plants in excellent order, and a stock of healthy and clean fruit-trees, perfectly free of the white bug.

After breakfast we visited *Mr Angerstein's Gardens*. The kitchen garden presented nothing remarkable. There were in the pine-stoves some very fine cactuses of a spherical shape, having from 15 to 21 sides or angles. We walked through the shrubbery to the pleasure-ground, and were introduced to Mr Macintosh, who has the superintendence of this department: he very civilly shewed us the grounds, and likewise the conservatory, which is placed at a little distance from one of the fronts of the house. It is a very large building, consisting of a centre 62 feet long and 31 feet 2 inches wide, and a wing on each end, 28 feet 8 inches long, by 25 feet 8 inches wide, in all 119 feet 6 inches in length. The height of the centre-piece may be about 28 feet: the wings are considerably lower. At one end of the building there is an arched passage under ground, leading to the furnaces, from 80 to 100 feet long, entered by a stair, which is screened with shrubs. This passage is lighted from the top by open grates. Considering the great space in this conservatory requiring to be heated, the furnaces would, in my opinion, have been better arranged, by having had one at each end, instead of two

at one end. If it were heated by steam-pipes, one fire would be sufficient. In this conservatory were many fine plants, the full height of the house. Before the conservatory was erected, the ground on that side of the house, where it stands, was a kitchen garden, and upon one of the walls there was an old Frankendale vine, 60 feet from the end of the conservatory. After it was erected, and the wall removed, the branches were all pruned off, and a trench being made, the vine was laid into it, and its top introduced at the end of the conservatory: here it now fills all the rafters of one of the wings 28 feet long, the roof of which is double. A little heap of earth, forming a rise in the grass, marks the place of the original roots. The gardener gave us cuttings of this vine, which he said was the true Frankendale, so much cultivated in Holland and Flanders. These Mr Macdonald engaged to take charge of.

Oct. 15.—This morning we went to Mr Grange's fruit and market garden at *Hoxton* near Kingsland. He kindly invited us to breakfast, and afterwards accompanied us through his extensive grounds. He has 57 acres under the spade. He was exceedingly frank and unreserved with regard to any thing we wished to see, or attain the knowledge of. It is about 17 years since he took possession of his grounds, and all the erections upon them connected with his establishment, which are very considerable, have been done at his own expence. It appears from a sketch which I took, that the hot-houses he had erected might be about 580 feet in extent: a great part of which were double roofed houses, projecting at right angles from a range of about 200 feet. At the back of these, sheds extend the whole length, suitably fitted up for the accommodation of

his servants and other purposes. It forms the largest establishment of the kind, that ever fell under our notice. He has introduced steam into two of his houses, in which he forces early strawberries, grapes, and French beans, to a great extent. In these houses, stages are erected pretty near the glass, for supporting the pots. He forces a great many of the Roseberry-strawberry of Aberdeen, and esteems it very much: he also forces several other kinds. He had about 15,000 pots of this plant ready for forcing, and said he had not been without ripe strawberries for 18 months past. When Mr Grange shall have finished the extensive suite of hot-houses he is now erecting (October 1817), and which is to be heated by steam; he intends to force peaches, grapes, cherries, figs, pine-apples, jargonelle-pears and apricots. He has also a large ice-house, chiefly above ground, and entirely built of wood. It is divided into three parts, and its roof has much of the figure of a large Dutch barn, approaching to the ground, and thatched 5 or 6 feet thick. When the ice in the first division is consumed, he opens a door into the second, and works through it to the third division. He keeps this for supplying his elegant fruit-shop in Westminster with ice. Mr Grange's green crops were very extensive, some articles occupying 3 and 4 acres each. He was planting out a considerable quantity of endive, on the slope of the banks at the roots of the hedges; and when he has not enough of these, he throws up others with the sloping face to the south,; on them he places four rows of tiles, stuck more than half way into the earth, with the convex side to the sun; a plant of endive is then placed on the opposite side of each. These banks he covers in winter with clippings of hedges, or with straw, to protect them from severe frosts. His brocoli and cauliflower were very fine, all from

seed saved by himself. His quarters of spinach, lettuce, celery, sea-calc, &c. were very extensive. The whole grounds are really managed in a most superior manner. Mr Grange is of Scottish origin, his father being from Maybole in Ayrshire.

Mr Grange kindly accompanied us to *Messrs Loddiges and Sons*, nurserymen, *Hackney*. The extent of glass here is little short of 1000 feet, and forms three sides of a square. It is all heated by steam, from one large oblong boiler, 11 feet by 4, of malleable iron. The houses are wholly applied to the propagation and rearing of greenhouse and hot-house plants; and these were in the very best condition. It was undoubtedly the most complete establishment of this kind we had seen in our tour. The houses in general are narrow; there is, however, a wide and lofty one in the north range, chiefly for palms, in which are two or three turns of the steam-flue. This is probably the largest collection of palm-trees in Europe; and several of the species are hitherto non-descript. *Musa superba* is a truly grand specimen, and *Cocos fusiformis* is also very fine. The *Asplenium nidus* from Java, one of the rarest of the fern-tribe, may here be seen. Several kinds of epidendrum are successfully cultivated, by planting them in split cocoa nuts, surrounded with sphagnum. Behind this palm-house the boiler is placed, and from thence one steam-pipe runs round the whole range. In the middle of the south side of the range there is another wide house, entirely filled with double camellias, of which they enumerate seventeen varieties*. It may be mentioned, that

* In July 1821, I had an opportunity of viewing a splendid new conservatory, which had recently before been erected here, under the direction of Mr Bailey, No. 272. Holborn. It combines much lightness and elegance of appearance with the durability resulting from the nature of the material em-

a $\frac{1}{2}$ inch lead-pipe, having numerous small perforations, is carried along the middle of the roof-glass: it is connected with an elevated cistern, and by turning a cock, this pipe waters the plants after the manner of natural rain. In the palm-house the surface of the flower-pots and tubs is covered with hyssop, to prevent the earth being spattered about by the falling shower. Messrs. Loddiges have not a great extent of ground, their whole attention being devoted to the cultivation of fine and rare exotics. In this pursuit, no expence appears to be spared, and they are most successful cultivators. I was in Mr Loddiges' grounds about 30 years ago, when he had only one small glazed house; but even at that time he excelled all in the propagation of American plants. Mr Loddiges senior is now far advanced in years; but his son Mr George Loddiges seems to possess all his zeal for plants, with greatly increased means of gratifying it.

ployed for supports being iron. The roof is of a curvilinear form, as recommended by Mr Loudon of Bayswater. This new conservatory is situate against the range of green-houses which face towards the south; consequently it has its front to the northward. It rises six feet higher than the back-wall of the green-houses, and this space affords an opportunity of ventilating the house, by means of a row of opening sash-windows at the back. The house is no less than 120 feet long, 23 wide, and 18 high. The sash-bars are of wrought-iron: these are inserted into a kirk or coping-plate of cast-iron on the front-wall, and into a rail at the back, also composed of cast-iron. This rail is supported by strong standards, and between these the ventilating sash-windows above mentioned are hung. The curved roof-bars are continued from one end of the conservatory to the other; and being naturally strong, and every where forming parts of an arch, the necessity of wide rafters, sash-frames and supports, is superseded. In this way is avoided the degree of shade necessarily produced by those parts in a nouse constructed with wood. The whole roof thus presents the appearance of a vast sheet of glass. This very remarkable conservatory has been described and figured by Messrs Loddiges, in one of the numbers of their "Botanical Cabinet." It is chiefly destined for receiving their vast collection of Camellias.—N.

After dining with Mr Grange, we went to *Mr Smith's* at *Dalston*. Here we saw a very large and good collection of geraniums, all arranged in separate houses; likewise a large collection of heaths, camellias, and other plants, principally for the supply of Covent Garden market. His heaths, and other hardy plants, are kept in pits or frames, banked up with earth, which sufficiently preserve them from frost. He was engaged in directing this operation when we visited the nurseries.

We here closed our horticultural excursion; and we leave several excellent nurseries and gardens around London unnoticed, merely because we could not accomplish a visit to them. Mr Neill being now able to travel, we all reached Edinburgh in the course of a few days.

The first of these was the discovery of gold in California in 1848. This discovery led to a great influx of people to California, and the state became one of the most populous in the Union. The second was the discovery of gold in Colorado in 1859. This discovery led to a great influx of people to Colorado, and the state became one of the most populous in the Union. The third was the discovery of gold in Nevada in 1846. This discovery led to a great influx of people to Nevada, and the state became one of the most populous in the Union.

The fourth was the discovery of gold in Idaho in 1860. This discovery led to a great influx of people to Idaho, and the state became one of the most populous in the Union. The fifth was the discovery of gold in Montana in 1862. This discovery led to a great influx of people to Montana, and the state became one of the most populous in the Union.

APPENDIX.

APPENDIX.

No. I.

*CATALOGUE des Arbres Fruitiers vendues par P. T.
De Cock, Marchand-Grenitier, Fleuriste et Pépiniériste,
dans la Rue dit Vieuxbourg, No. 32, à Gand.*

(Referred to at p. 44.)

PECHERS.

Melecoton vermeil rouge.	Brugnon violet.
Teton de Venus.	doré (new).
Pêche Quesnoy.	imperial.
d'Hollande.	paderel (said to be Flemish).
Grosse mignonne.	Pêche rouge precoce.
Madeleine rouge.	dorée.
blanche.	Grand Hamelinck (said to be Flemish).
Tardive rouge.	Pêcher à double fleur.
blanche.	
Brugnon blanc (new).	

POIRIERS.

Saint Laurent.	Roussellet de Rheims.
Grande cuisse madame.	Poire du jardin blanc.
Callebasse.	Belle Seingne.
Orange musqué.	La belle de Bruxelles.
Grand Seigneur.	Virgouleuse.
Petit mouilli.	Saint Germain.
Bergamotte du vin.	Louise bonne.
Citron des Carmes.	Sucré vert.
Bergamotte d'automne.	Mansuette gris (like Achan, but larger).
Grand musquée d'été (like bonchretien).	Grande Bretagne.
Cressanne.	Caillot-rosat.

Colmars d'hiver.	Glous morceau.
Passé Colmars.	Poire de Louvain,
Rousselet d'hiver.	Poelman.
Bugimotel.	D'Estine.
Bon Chrétien d'hiver.	Robine.
Seigneur d'hiver.	Grand Resseghem,
Beurré gris.	Poire Philipse.
Beurré blanc d'été.	Annas poire.
Messire Jean gris doré.	Mouille bouche.
Poire Capuchin.	Premier d'été.
de livre.	Rousseline d'été.
La Reine d'hiver.	Bergamotte d'Angleterre.
Mansuette d'été.	Poire d'or.
Poire de Nôtre Dame.	Beurré d'hiver.
Royale blanche.	Beurré d'or.
Bergamotte bugi.	Dorothé royale.
Angelique de Bourdeaux.	Callebasse blanche.
Poire sans pepin.	Doyen gris.
Gros Seignolé.	Beurré d'Ardenpont (new).
La jalousie.	Beurré Anglaise.
Culotte suisse.	Marquise d'automne.
Bon Chrétien de rose.	Poire d'orange.
Le Grand Monarque.	Beau-present.
Beurré vert.	Bon Chrétien doré.
Nouvelle gagné (autumn pear).	Busi de Chacris.
Marquise d'hiver.	Marquise Dame d'été.
Delice d'Ardenpont (winter,	Epine d'hiver.
large).	Poire de Miloen.

POMMIERS.

Courtpendu rose.	Reinette d'Angleterre ou Pe-
vert.	pin d'or.
blanc.	Pomme d'Astracan.
noir.	La belle d'Angleterre ou
Calvil blanc.	grosse reinette.
à cote.	Pomme noir.
Rouge.	Pomme de Comté.
Pomme d'Api.	Grand riée.
Reinette gris.	Verdier.
blanche.	Pomme d'asiette.

Pomme de pére.	Fenouillet.
Belle fleur.	Purinelle.
Sans pepin.	Reinette franche.
Calville blanche d'été.	

PRUNIER.

La petite verte.	Longue bleu.
La rouge ronde.	Prune de St Catherine.
La longue rouge.	royale rouge.
Prune d'abricot.	Prune d'automne bleu.
Reine-Claude grande jaune.	Mirabelle incarnate grosse.
Prune d'oeuf blanche.	verte.

ABRICOTIERS.

La petite brune precoc.	L'abricot-pêche.
La jaune mainlu.	Le grand machol.
La grande brune.	Le crapaudé.

CERISIERS.

Cerise rouge de Mai.	De Bruxelles rouge.
de St Jean rouge.	Grande noire.
Courte queue (Flemish).	Guigne de Mai (red).
La grande rouge.	Guigne du vin (black).
A double fruit.	

Et beaucoup d'autres, comme Muriers, Coignassiers, Noyers, Nefliers, Noisette d'Espagne, &c.

No. II.

*An ESSAY on the Culture of Hyacinths, by JOHN KREPS,
SON and COMPANY, Florists at Haarlem*

(Referred to at p. 176.)

The bulbs of hyacinths are subject to a disease or corruption of the sap, which occasions the destruction of many, in-somuch, that the foreign amateur is disgusted and tempted to abandon entirely the small hopes he entertains of ever seeing his endeavours crowned with success.

Without once giving himself the trouble to examine the probability of his opinion, he takes it for granted, the climate

of Holland is alone favourable to the culture of the hyacinth. But we trust we shall be able to undeceive him, by the observations and rules we shall lay down; and we beg leave to assure him, that if he will implicitly follow these directions, he will be able to bring them to such perfection, as not only to equal, but even vie with those raised in Holland, both as to strength and beauty, nay, perhaps, surpass them.

The disease incident to the hyacinth, we have already observed, is a putrefaction of the juices, and the occasion of it may be attributed to the three following causes.

1. Want of good compost.
2. Too great moisture.
3. A want of due perspiration.

Of the Compost or Soil.—We shall first lay down a rule for preparing the proper soil or compost, most adapted to the hyacinth, not with an idea of its being the only proper one, and no other; but to give the amateur a rule, by which he may make the soil of his garden approach as near as possible to the compost we are about to describe, in which the hyacinth thrives best.

- $\frac{1}{4}$ White river sand, or such as the hills about Highgate and Hampstead abound with, seemed to us might well answer to our sand in Holland.
- $\frac{1}{4}$ Manure made of leaves well rotted.
- $\frac{1}{4}$ Cow-dung thoroughly rotted.
- $\frac{1}{4}$ Old tanners-bark.

The bark must be that which has been used by the tanners, and laid in a heap at least for one year, that all the heat may have been exhausted.

These materials should be well mixed together, and frequently turned, during one year before they are used.

By what has been said, it may be observed, that it is only meant to insinuate, that the soil must be light, fresh, and well turned. The consequences thereof will point out its utility.

Those who have only a heavy soil, and cannot, with ease, procure such materials as sand and rotted leaves, may supply the deficiency, by mixing with $\frac{1}{4}$ of their soil, with $\frac{1}{4}$ of thoroughly rotted tan; and those who want tan, may increase the propor-

tion of sand or of rotted leaves, because either of these articles may supply the deficiency of the other two.

You must observe to proportion the quantity of these light materials, according to the strength or lightness of your soil. The heavier or stronger it is, the less cow-dung you must use.

Having prepared a spot in your garden, after the foregoing manner, you may plant thereon *greens*, during the summer, and Windsor beans in preference; because these last serve best to mix and unite the different materials, and thereby form a natural soil, which ought to be your aim. For it is necessary to be informed, that all composts that are not well mixed, are of little or no use in gardening.

Of Moisture or Wet.—Wet or damp being the most destructive incident that can happen to hyacinths, great care should be taken to protect them from it, by choosing the most elevated spot in your garden; if that is surrounded at a small distance, with a shallow trench, it will be the better. Besides, the bed wherein you mean to plant your hyacinths, ought to be raised 7 or 8 inches above the level of the garden. Do not imagine that this precaution is useless, with an idea, that in England, and in many other places, they have little or nothing to fear from damp, because those countries are more elevated, and lie drier than in Holland,—an opinion much too prevalent, and too much disseminated among foreign amateurs, and which occasions a loss to them of many bulbs. Among all the treatises which have as yet appeared on the cultivation of the hyacinth, none have made any observations, or at least only very superficial ones, on this important circumstance of damp, and that because they suppose foreign countries have nothing to fear from it.

Let us undeceive them, by pointing out to them, that damps and moistures are more detrimental in those countries than in Holland. The truth is, the soil being prepared, as we have already pointed out, is very light, consequently more disposed to absorb those rains and snows which fall, from the months of November to March, and particularly affects these beds; and the paths around them being more close and compact than they are in Holland, the moisture cannot be absorbed by them so quick, but remains upon the bed, and contributes to render them so wet, that they absolutely become mud, to the depth of 8 or 12 inches.

The bulbs having, at that season, pushed out their roots to the depth of 16 or 20 inches, their extremities become immersed continually in water, which, by fault of a descent, to occasion its running off, joined to the little transpiration the vegetable world has during the winter months, causes the roots to putrefy, and communicates a disease to the bulbs, which totally destroys them, or at least renders the flower poor and small. The bulbs become thin, and when taken up, they will be found shrivelled, and all in scales.

To prevent this misfortune as much as possible, we would advise those amateurs, in cases of heavy rains, or melting snows, to give a vent to them, by either making small descents to drain them off, or rather to have small trenches dug round the beds, as we have already mentioned, and to be particularly careful to raise the beds at least 7 or 8 inches above the common paths.

Of Evaporation.—The bulb of the hyacinth is succulent and full of sap, which is the reason that for want of due evaporation it very easily putrefies,—a misfortune which we must endeavour to prevent as much as lies in our power. To prove that the bulb abounds with rich juices, take eight or ten roots at the time of transplantation, or rather the time of taking them up; they will perhaps weigh 1 lb. Three weeks after having lain on the shelves, you will find they will only weigh 12 oz., so that they will have evaporated one-fourth part in that space of time.

These vapours being condensed either in the room or in deep drawers, in which they may be laid to dry one upon the other, have the same pernicious effects as the wet and moisture in the ground has, when it is not made to be drained off; that is to say, it occasions putrefaction, and totally destroys the bulbs.

The place destined for the reception of the bulbs, after taking them up, ought to be very dry. For this reason, greenhouses which are naturally placed to the south, are preferable to any other place.

The windows should be open on all sides, or at least on two or three, that the air may have a free passage, especially during the first three weeks, after the bulbs have been there deposited. During this interval all the windows should remain open, excepting when the weather is cloudy, at which

time they ought to be kept close shut; likewise in the morning and evening at all times.

Every precaution ought to be taken to prevent the humid vapours arising from the bulbs settling on them, which occasions putrefaction: it is for this reason that rooms or garrets, which are lined with wainscoat, or have wooden partitions, or that are built entirely of wood, are preferable to walls of stones, brick or plaster. It seems that stone walls particularly attract the humid and moist vapours; for, if the weather remains cloudy for two or three days together, these kinds of walls appear covered with a moisture which scarce ever happens to those of wood. In the month of September the sap in the bulbs begins to move, and it then becomes highly necessary to pay particular attention to them, because at that period they are most subject to putrefaction, by sucking up the same vapours which they have evaporated in the months of July and August, if proper care has not been taken to keep them in dry and airy rooms.

This remark will appear to many people absurd and ridiculous, but experience has taught us the truth of it, and the considerable losses we have sustained have confirmed it.

Again, amateurs, who have had a little experience, to prevent putrefaction taking place, examine with attention each bulb before they lay them on the drying shelves, and reject without exception all those that are anywise unsound. This caution they renew prior to their replanting them, to prevent as much as possible all infection.

It is much preferable to place the bulbs on shelves separately, and distinguish the different sorts by placing small slips of wood with marks on them, than to put them in small deep drawers, whose depth prevents the air from having a free circulation through them. You must likewise carefully observe to turn the bulbs from time to time, during the first two or three weeks after having laid them on the shelves, to facilitate the evaporation, and not lay them on their base, but on one side; because otherwise the moisture accumulates and attaches itself more easily between the old roots, which to get rid of is attended with much difficulty, and, if it remains, it occasions them to perish for want of evaporation.

To convince yourself of the necessity there is to follow the rule herein mentioned, is very easy, alone by examining the

rooms wherein you deposited the bulbs, during the first two or three days. On your entrance into them in the morning, after having been close shut up during the whole night, as they must and ought to be, on account of the dew which falls at that time, you will perceive a very strong smell arise from the bulbs, and, if the collection is considerable, the room will be quite heated by the exhalations arising from them, which entirely goes off as soon as the air has had a free passage for a short space of time.

As our remarks are entirely designed for the use of amateurs of flowers, particularly for those who delight in the culture of hyacinths, we have dwelt on such observations as we deem the most essential; and we will endeavour to explain, in as few words as possible, what remains to be said, and what we think is most interesting.

The best season for importing bulbs from Holland is in the months of August and September, because at that time they have undergone the proper evaporation, and can best endure carriage.

Of Planting.—When the soil of your garden is very dry and elevated, you may plant your bulbs 7 or 8 inches deep; but if you prefer a strong and vigorous flower to a large and well nourished bulb, 5 or 6 inches depth will be sufficient. Those who have gardens in town where a descent is less practicable, and where the air is more loaded with vapours, should plant them only 5 or 6 inches in depth.

Suffice it to say, that the deeper your soil will permit you to plant them, the wholesomer and stronger will be your bulbs; but in no soil whatever you ought to exceed 8 inches in depth.

Of Frost.—Frost is alone detrimental in proportion as it approaches the bulbs; so that the intensity thereof ought to be your guide, in respect to covering them at that time. One or two inches of tan laid over them will be sufficient in a common winter. Those who have bulbs of great value, may add thin planks of wood when the frost is very intense.

But you must take care not to cover them too thick, especially with too many leaves of trees; because these coverings repulse the vapours which arise from the ground, although frozen, and hinders the air from penetrating it, and consequently purifying it. A frost which penetrates only three or

four inches deep, is with us preferred to too mild a winter, or to the inconvenience sustained by too much covering. Those who have collections of great value, tie up the stalks to small sticks, and put on an awning, so as to throw a shade over them during the greatest heat of the sun, thereby preserving the beauty of the flower, more especially those which are of a deep red colour. But, at the same time, they have the precaution not to extend the awning over the whole bed, and only to use it at all from 9 or 10 o'clock in the morning to 5 or 6 in the evening; because whatever contributes to increase the growth of the stalk and leaves, weakens the bulb, and renders it poor and small.

Of taking them up.—The time for taking them up, is when the leaves have lost their verdure and begin to wither. If your garden is very much elevated, you may indeed wait till they are entirely dry and withered; but then you must be certain you have nothing to fear from the humidity of your ground. The general custom with the Dutch florists is to put them in the earth again, as soon as they have stripped them of their leaves, and they practise the following method.

After having taken up the bulbs, they make the beds quite even; then, cutting off the leaves, but not too close, and leaving the roots, they lay the bulbs on their side in regular rows, so that they just touch, taking care to lay them in a full south aspect; there they cover them with fine earth, about one inch thick, which raises them three or four inches above the surface of the beds. In this situation they remain three weeks, taking care to remove or rather renew the mould from time to time, that may be or is blown away by the wind. About the end of this period, they take up the bulbs, clean them, and take off the offsets, and place them on their proper shelves. This method is highly useful, and very favourable to their evaporation. It renders the bulbs very dry and compact, consequently more adapted for carriage; it likewise prevents their being mouldy and their putrefying.

The above method is alone practicable in a soil that is light and dry, and that has been well turned. Where the soil is strong, deep, and moist, it would be very dangerous to follow this method, and you might, by so doing, totally lose all your bulbs.

Those who possess the favourable soil above mentioned, may take up their bulbs as soon as the leaves begin to grow

yellow; and, on the contrary, those who are not so fortunate must wait till the leaves have entirely lost their verdure and are withered.

If the rules laid down in this small treatise (which is alone designed to point out those that are indispensably necessary to be observed in the culture of the hyacinth) be implicitly followed and put in practice, we are convinced the amateur will find their good effect, and that this flower will succeed in other countries better than it has hitherto done; and he may flatter himself, with some reason, if he pays proper attention, and proceeds with perseverance, that he may bring his hyacinths to as great perfection as they are in Holland. The experiment will, without doubt, cost him at first some bulbs, but that is inevitable; for even in Holland, where the cultivation of this flower is attended to, with the most unremitting care and attention, they have not yet discovered the secret of saving every one. Notwithstanding the experience of many years, the hyacinth still remains a very difficult flower to raise; but perhaps this difficulty arises in some measure from the great moisture and damp of our climate.

The hyacinths must never be planted again in the same soil, but the ground must at least rest for two or three years, or be cultivated with greens during that time, and always mixed again, the year before planting, with some old cow-dung, especially when your soil is light or sandy, as the hyacinths are very fond of that stuff.

The trials and experience of many years have brought the Dutch to a tolerable perfection in the culture of this flower. Our intention with the foregoing rules, is only to give a hint to the foreign amateurs what way they must turn their attention to mend the culture. Many soils may be found in England, which, with a few additional stuff, may perfectly answer to the desired effect. The better success that may be reaped from this pamphlet, the more we shall esteem our trouble well recompensed; as for style and language we vouchsafe a double indulgence, being neither authors nor Englishmen, but wellwishers to all flower fanciers.

No. III.

*LIST of some New Roses, raised by Mr Brown of New
Scone.*

(Referred to at p. 179.)

The finest of the Double Scots Roses (or those from *Rosa spinosissima*) having been fully described by Joseph Sabine, Esq. Secretary of the Horticultural Society of London, in the Transactions of that Society, vol. iv. it seems unnecessary to particularise them here. Mr Brown of Perth made trial of the seeds of other kinds of garden roses, about the year 1796, and procured several seedlings of great beauty, particularly the following.

Venus, a small double white, without prickles, perhaps the finest rose yet produced in Britain, raised from seed of the garden White Rose, (*Rosa alba*.)

Duchess, double blush, raised from the Maiden Blush.

Diana, double blush, raised from the same.

Victoria, dark and double, superior to the Tuscany.

Parson, do. do. equal to the Tuscany.

Mount Etna, dark and double.

Mount Vesuvius, do. do.

Vagrant, do. do.

The above five raised from the double Velvet, R. Gallica.

Fair Maid, pale red, semi-double, in habit allied to the blush China rose, raised from the Portland or crimson monthly, R. centifolia.

Blush-tree Burnet-leaved, double, raised from the single Burnet-leaved, with shining or glossy leaves, and red berries.

Dwarf Burnet-leaved, double, raised from the same.

Chance, double blush, raised from double Damask, (R. damascena.)

Great Mogul, double, raised from the red Belgic, (R. damascena.)

Purple, double, raised from crimson Dutch and Dutch hundred-leaved, (R. Gallica.)

<i>Miss Bold,</i>	} double, raised from the Princess, (R. Gallica.)
<i>Favourite,</i>	
<i>Flora,</i>	
<i>Ruby,</i>	

Most of the above are very different in flower and habit from those they were raised from, and from any other roses. Mr Brown possesses a new rose of considerable beauty, raised at New Scone, and which first flowered in summer 1821. He calls it the Coronation Rose.

No. IV.

1. *EXTRACTS* from the Scots Gardener's Director, by
JAMES JUSTICE, F. R. S. &c. Edinburgh 1754.

(Referred to at p. 200.)

So soon as the hyacinth roots arrive from Holland, I would incline to plant them, provided it is any time after the middle of September, that season being the best for planting the double hyacinths, which I would perform in the following manner: Stake out a convenient place in the garden, not too near a wall or hedge, and at the same time sheltered from winds and storms as much as you can, of what length you please, but of breadth 5 feet, and taking out the natural earth to the depth of 3 feet clear below the surface of the pathway, level the bottom thereof; then lay in 8 inches height of suitable compost; and levelling this, lay above it 16 inches of the reserved heap of dung and sand, after you perceive it has been well rotted and made very fine; by this means, 24 inches of the 3 feet will be filled up of this trench; and my reason for laying the 16 inches of this well rotted dung, and a fourth part of sand, is, that the extreme parts of the fibres of the hyacinths may reach the same, that they may from thence suck what is sufficient to furnish a strong flower for the succeeding year, to refurnish the great succulency of their strong stems and bells which they send out every year. Above this dung and sand, fill the bed up with the compost until it be near equal with the surface of the path-way; then lay on the surface of the compost 1 inch of your sandy earth, the purest and finest that you have. Take your roots, and plant them four roots broad, in a bed of 5 feet breadth, in a quincunx order; and be sure that each of the outermost rows be 6 inches at least, from the outmost verge of the bed, and 11 inches

root from root every way, thrusting them down with your hand into the earth more than 1 inch, to keep them fast, so as not to be overturned by the laying of the compost above the bulbs, to the height of 3 inches; above that, riddle or lay on 1 inch of good garden-earth, whereby there may be 4 inches of earth above the bulbs. I have often, after planting the hyacinths bulbs, about the beginning of October, covered them with no more than 2 inches of their compost, until the beginning of *November*, and have had great success with them by this method; for to my experience I know, that if there is too much earth above their roots, they will not strike out one fibre, and the roots will rot infallibly; because too much earth above the new planted roots, excludes the air from them: As soon as the frosts set in, or by the end of *November*, I always covered my beds of hyacinths, doubles and singles, with 3 inches of old rotten tan-bark, or fallen leaves of trees, and also 2 feet beyond the ends of the beds, and filled the alleys betwixt the beds (which may be 2 feet broad) as high as the top of these beds, with this rotted tan, which I did not take off them, until the end of *February* or beginning of *March*, as the weather is good or bad; and if the tops of these beds are raised 4 inches above the path-way, I laid in the old tan into the alleys of the beds, to the height of the tops of the beds, to prevent the frost getting into the bulbs which are planted upon the outsides of the beds. I very often covered the tops of the beds with pease haulm, which defends against frost, as well as the bark, is a lighter cover than tan, and is more airy, so as the wet rancid vapours from the tops of these beds of rich soil, may pass more easily off through this straw than through the tan, which will prevent the complaints of the roots of hyacinths rotting, after they are planted, and have struck out their fibres, which often happens. I also observed, to plant a double white and a double blue hyacinth in the first row, and so alternately the whole length of the bed, planting always those together, which blowed at a time, or at one and the same season; that is, early blowers, second blowers, and late blowers, all by themselves, and as near together as possibly the season of their blowing can admit. And the second row I begun with a double blue, and then a double white, in the quincunx order, to the end of the row, and in the same manner with the third and fourth rows. I observed, also, to remove the tan with

the hand only, and not with any instrument, in case of injuring the young buds of the leaves and flowers of the hyacinths, which are then boldly springing to the surface of the ground. As soon as I perceived the leaves and flowers-buds come above ground, looking my written pocket index of roots, and the method of planting them by their names to the different roots, near by them I affixed labels of wood, with painted numbers on them, as marked in an index, such as No. 1. to *Morgen Star*, double white, and No. 2. to *Passe-toute*, double blue hyacinths, and so on, through the whole bed, so as one cannot be mistaken to lay those roots distinctly in their respective repositories, in the root room, at lifting season, when their flowers are decayed, and some of their leaves gone. This I notice here, for the benefit of a distinct florist, or nurseryman in flowers, for his exactness, and which was always my practice. You must put some covers over these flowers when they are in bloom, and even before they blossom, to preserve their flower-buds before they open, from frost, snow, hail, or much rain. The Dutch plant their best hyacinths into frames made of wood, in shape and form like unto these frames under which early cucumbers are raised, and have wooden covers for them in winter, and lift these higher up when their flowers are in bloom. But with submission to these eminent florists, I would never advise such covers; for by this method of covering these flowers, they are drawn up and choaked, which ends in the ruin of their roots, as I have often seen, and sometimes experienced.

The best covers for hyacinths when they are in bloom, are painted cloth or mats, sustained by arched hoops, which may be fixed on frames upheld by 2 feet high stakes of timber, drove into the ground of the alleys of the beds where they are planted; these frames may lift wholly off, or if the frames continue on the beds, the mats or cloth may be so contrived, as to take off at pleasure, to give all air in mild weather, which will preserve the flowers and their roots in good health.

When the stalks of the flowers spire up, I tied them first gently below the bells to iron-wires, made on purpose; and when the bells separate, open and prepare for flowering, I tied a piece of bass-mat genteely betwixt the bells, to sustain their stems and flowers to the wires, which makes a very handsome appearance; and when their flowers are faded, I gathered up their long leaves and stems

to the iron-wires, and tied them, but so easily as not to break them, or to incommode or hinder them from growing long, which then they do, but only to save them from breaking, bruising, or wind-waving. Five or six weeks after they have done blowing, and their green leaves are turning yellow, 4 or 5 inches below their tops, I lifted them carefully out of the ground, immediately cutting off their leaves and stems close to their bulbs; I laid them directly with their respective labels in their apartments, in boxes, in the root-room, to win and dry by the air and wind, but not by the rays of the sun, observing to take none of their fibres off, but to allow them to wither; for they never take any rotting from their fibres, but from their broken or bruised leaves and stems that are left at the roots, by the practice of some persons, of which I must necessarily take notice, since it is practised and erroneously followed by many, and which long experience has taught me to be the utter destruction of those roots.

They advise to lift them at the same time I prescribe for that operation, but then they order these roots, with their leaves and stems remaining at them, to be laid on their sides, into a sharp ridge of the ground, wherein they were planted, ay and until these stems and leaves are withered, and the roots (as they say) are ripened: I must say, I have in many cases, and in many seasons, found this practice to be very wrong; for when these roots are taken up, and laid upon their sides, with their leaves and stems hanging at them to ripen, (as they term it), these may thereby wither indeed; but before they are dry, it is very probable that some putrefaction, descending from the dying green leaves and stem, affects the bulb, notwithstanding of all care to prevent it; besides, if these roots, which, when thus laid on their sides, are very thinly covered with earth, and are not preserved from heavy showers of rain, and possibly exposed, immediately after, to a hot sun, to dry the earth in which the bulb lies; the same, by the hot rays of the sun, will be boiled in a manner, and will be liable to rot. It is certain, that the rotting of those bulbs proceeds oftener from their decaying leaves and flower-stems, than from the fibres of the bulb; therefore it is safer to take away the cause of this rotting, and the effect will cease, by cutting off these leaves, and decaying flower-

stems ; and afterwards you may either ripen the roots, by laying them upon the top of the beds wherein they blossomed, covering them with a little dry sand, and shading the roots in the hottest sun, with mats betwixt them and the sun, not laid on the earth, but hung as parasols or sun-shades, by which means the roots thus laid, have free air at all times ; or at lifting season, you may lay the roots into the root-room, into their respective drawers, to win and dry there by the air and wind, but not in the rays of the sun.

Any of these methods you may follow ; the nurserymen are for ripening their roots in the earth, as it gives the outward coats or skins of the roots, a harder substance, so as they may pack better to go abroad ; whilst some curious florists follow the other method, with the same success. This last method I chused to practise with my finest hyacinths. Most people who receive hyacinths from Holland, complain that they degenerate, and do not flower well with them a year or two after they receive them : it becomes me to show them, that, provided they observe strictly, a few rules, their hyacinths will blossom for many years, as well as they do in Holland ; and that without such a strict observation of these rules, it cannot be expected. And,

1mo, It is certain, that most part of our soils in Britain, have more or less clay in them, excepting pure white sand, or dark grey sandy earth, which is found near the sea, or upon grounds where short tufty heath grows ; these soils are the most proper for hyacinths, and I always took four shares of old well-rotted cow-dung, one share of pure white sand, and one share of this dark-coloured sandy earth ; and in this soil only will they prosper ; for if there is clay in the ground wherein they are planted, their roots turn into a dull skinny unactive bulb, and have not five, instead of fifty fibres, they should emit to furnish a large bold flower.

2do, Hyacinth roots should never be planted in any place of a garden, wherein water stands in winter, either above or below ground.

3tio, You must use no dung in your compost, but that of cows ; and it must be very well rotted, and two or three years old ; or for want of this dung, old rotted tan-bark, or rotted leaves of trees will do.

4to, You must not use for this compost, that earth where, in hyacinths have been often planted, without other crops

nor ever suffer those roots to continue in the ground two years, for they must be lifted every year.

5to, Do not plant good and sound hyacinth roots in the same bed, or near to roots which you see are not sound, seemingly rotten or unseemly in their appearance; for such roots will infect wholesome ones.

6to, Be sure to sow hyacinth seeds every year, for thereby you may raise (as I did) many different fine sorts of those flowers, as good, and more to be depended upon, than such as we get from Holland.

7mo, If you do not sow their seeds, or that you want to increase some of the prettiest sorts of them, and these roots are shy to off-set, (which is often the case with many of their best sorts) you are to use the following method to obtain off-sets from them, and which are more to be depended upon for their flowering handsomely, than the roots you get from Holland. The method is thus: a fortnight after they are past their bloom, take such roots as you chuse to have off-sets from, out of the ground, cut off their long leaves and flower-stems, but do not take off their fibres; and just above the circle from whence spring these fibres, cut the bulb cross-ways in four quarters, a third part into its substance, but so as not to touch its innermost coats or its heart, then wiping it with a cloth, put it into the ground again, and cover it with no more than one inch of ground; lift this root again in three or four weeks afterwards, and lay it again into the root-room with the others, and at the usual season replant it with the other roots. This root will not bear a flower the ensuing season, but in place thereof, will, at lifting season, give you six, eight, or ten large off-sets, which, as they are bred (I may say) in our soil and climate, are much more to be depended upon for blossoming well, and for continuing to do so, than any roots we get from Holland. Nor is there any fear of their roots degenerating, provided they are lifted out of the ground every year, and that the new soil here prescribed is given to them annually at their being replanted, together with the other directions here prescribed for their culture: And as I have had repeated experience, I affirm it, that I have had the same roots blossom fair with me for six years *toute suite*, and would have continued to have blossomed some years longer, if the roots had not expended their strength by off-setting. If you continue them two years in the ground without lift-

ing, the ground must be very rich and strong at first: but this method is dangerous, many of the roots being apt to rot thereby.

2. *EXTRACTS* from *The Dutch Florist*, by *NICHOLAS VAN KAMPEN of Haarlem*. Translation published at *Newcastle-upon-Tyne*, 1768.

(Referred to at p. 200.)

HYACINTHS.—*Soil, &c.*—Sandy earth is what we consider as the base of the culture of hyacinths. It ought to be of a bluish-grey or blackish-red colour, not sharp, but rather handling smooth, a little greasy, and taking a pearl colour when dry; the water passing through it being sweet and of a delicate taste; in a word, such soil as we see about Haarlem, particularly towards the sea-banks. (P. 4.)—The best method of enriching sandy earth, according to our experience, is to make use of cow-dung, rotted leaves of trees, and tanner's-bark; but the bark ought not to be taken fresh out of the pits, but laid up for two years at least, that it may be well rotted, and consumed to one-half.—Our method, then, of making compost for hyacinths is as follows: Two-sixth parts of grey sand; two-sixths of well rotted cow-dung; one-sixth of tanners-bark, quite rotted and reduced to earth; one-sixth of tree-leaves, also well rotted.—All these materials must be thrown into a heap, not more than three feet thick, so that the rays of the sun may have power to penetrate through it, and warm it to the bottom; for which purpose the heap must be laid in a high and open place exposed to the south. Once a month it ought to be carefully turned, and the bottom thrown to the top, that all parts of it may partake of the benign influence of the sun and elements: this is essential; and this turning must be continued for twelve months, taking care not to sift the compost, because, in that case, it is apt to run into lumps, which would be of dangerous consequence. (P. 5, 6.)

Beds.—After a place has been pitched on for planting the flowers, the natural earth must be dug out to the depth of three feet, and the bottom covered with a stratum of cow-dung, half a foot thick; which must be beaten and trod down, till it be very firm and compact, like a hard crust, so

as to prevent any communication with the subsoil. Then the hole is to be filled up with compost, six inches above the level of the garden. The compost should be laid into the designed bed, about a month before the roots are planted; for if it be put in later, the earth might settle while the roots are in it, which would lay them too deep.

Planting.—The proper season for putting in the bulbs is October or November. They ought to be set at the depth of four or five inches; but early flowering varieties may be one inch deeper, which will bring them to flower at the same time with the others. (P. 8.)

Protecting during Winter.—In hard frosts the beds should be covered with tanners-bark, leaves or straw, to the depth of three or four inches. This covering should be removed early in spring, before the rising plant has penetrated it, otherwise the leaves get a pale disagreeable yellow colour. The beginning of spring, however, being subject to great uncertainty, those that plant in beds having boards along the sides, should make use of sliders or covers during the night, or in great winds or frosts: those that plant in a terrass, must take care to cover them, with mats or reeds, which should rest on supporters two or three feet from the ground. (P. 11.)

Supports.—The flowers are to be supported by means of strong wires, two feet long and painted green: these are to be stuck into the ground as near the plant as possible without touching the bulb; and the stalk is to be tied to the wire, with a green thread, above the lowest bell. (P. 12.)

Shades.—When the flowers are almost in full blow, a shade of canvas, in the form of a tent, is proper, for screening the whole bed both from sun and rain; the awning being so contrived, that the canvas may be raised in the mornings and evenings, &c. (P. 13.)

Taking up the Bulbs.—We take up the roots as soon as the leaves begin to wither, that is, when their plants begin to turn yellow. We then break off the stems an inch above the bulbs, which we afterwards cover with earth, in which they are to lie till the gross moisture be dried up by the warmth of the sun. We make a little heap of earth, and place the roots in it, bottom downwards as they grew; and the heap is covered with an inch or two of soil. When the bulbs have lain in this heap for three weeks, they are to

be taken out in fair weather, and laid on a board in the sun for an hour; after which they are to be cleared of the earth and offsets about them, taking great care not to give the least bruise or wound. (P. 16.)

No. V.

REMARKS on the cultivated Elm-Trees, with Characters of the British Species. By Mr DAVID DON, Curator of the Lambertian Herbarium.

(Referred to at p. 256.)

The real Dutch elm is undoubtedly the *U. major* of English botany, the *Ulmus Hollandicus* of Millar's Dictionary. It approaches very near *Ulmus suberosa* of Erhart and Willdenow, and appears intermediate between it and the *montana* of *English Botany*: still, however, I think it is sufficiently distinct from either. The *Ulmus suberosa* is a very distinct species. It is, like the *major*, a worthless tree, of a stunted and rugged aspect. This species is often sold by the nurserymen for the Dutch elm, and frequently confounded by them with the English elm, to which, in a young state, it bears considerable resemblance. The *Ulmus montana*, which has a rugged and somewhat corky bark, is rather a shrub than a tree. It divides at the bottom into many branches, and never grows to any considerable height. It is frequently used in hedge-rows in some parts of England, and is the best adapted for that purpose of any. The *Ulmus campestris* has much smaller leaves than any of the other species; they are ovate, acute, doubly serrated, rough, and strongly veined, with their base nearly equal,—flowers 4-cleft, with four stamens; laciniae obtuse; fruit oblong, obovate, cloven at the top; bark rugged, much more entire than that of *U. suberosa*. This grows to a large tree.

Ulmus glabra of Millar's Dictionary, forms one of the finest and most useful trees, being superior to all the preceding species. It is readily distinguished by its smooth, dark lead-coloured bark, and by its leaves, which are nearly smooth on the upper surface. This tree is common in Scotland, and forms a great proportion of those kept in the nur-

series. It is the most prolific, and the shoots and wood are the most tenacious of all; hence it was formerly, in the days of archery, in much request for making bows.

The genus *Ulmus* is one of those whose species, like those of *Salix*, are so nearly related to each other, that they are often confounded, and their differential characters not easily discovered; nevertheless, an attentive observer will perceive something in their different habits, which, although not easily expressed in words, leads him to remark other differences. We must not, however, expect to find so many tangible and decided marks in such genera, as in those tribes whose species are farther remote from each other. The characters of the British species I shall subjoin, from my own manuscript notes.

Samaris nudis.

1. *U. glabra*, pentandra; floribus sessilibus 5-fidis obtusis, samaris obovatis apice bifidis, foliis latè oblongo-ovatis duplicato-serratis suprâ lævibus basi valdè inæqualibus, cortice integrâ lævi.
2. *U. montana*, pentandra; floribus pedicellatis 5-fidis acutis, samaris subrotundis emarginatis, foliis ovatis brevè acuminatis duplicato-serratis scabris basi subæqualibus, cortice rugosâ.
3. *U. campestris*, tetrandra; floribus subsessilibus 4-fidis obtusis, samaris oblongo-obovatis apice fissis, foliis acutis duplicato-serratis rugosis basi subæqualibus, cortice rugosâ.
4. *U. suberosa*, pentandra; floribus brevè pedicellatis 5-fidis obtusis, samaris subrotundis apice fissis, foliis latè ellipticis cuspidatis duplicato-serratis basi valdè inæqualibus, cortice suberosâ rimosissimâ.
5. *U. major*, tetrandra; floribus subsessilibus 4-fidis obtusis, samaris obovatis apice emarginatis, foliis amplis ellipticis acutis duplicato-serratis scabris basi inæqualibus, cortice suberosâ rimosissimâ.

No. VI.

On the Advantages of planting Fruit-Trees on Declivities, in a Letter from the Rev. Dr JOHN WALKER to Lord KAMES, dated Moffat, Feb. 18. 1773.

(Referred to at p. 261.)

Dodart first observed that trees pushed their branches in a direction parallel to the surface of the earth. If a tree stands on a steep, it pushes both towards the hill, and towards the declivity; but on both sides it still preserves its branches parallel to the surface. As there is an attraction between the upper surface of leaves and light, I am also persuaded, though not equally certain of it from experiment, that there is an attraction of the same nature between the under surface of leaves and the surface of the earth. This I consider as the cause of the phenomenon.

I had long observed, that the most fruitful orchards, and the most fertile trees, are those planted on a declivity, and the steeper it is, though not quite a precipice, the more fertile they prove. But I was never satisfied as to the cause of it, till I called to mind the above observation of Dodart; which occurred to me when I was in the town of Jedburgh. There is more fruit about that place, and more fruit-bearing wood upon the trees, than I have seen in any other part of Scotland: But its orchards and fruit-gardens are mostly situated in very steep places.

It is well known that the spreading of trees always renders them fruitful. On a plain, however, they incline to shoot upwards; and therefore art is called in by skilful gardeners, and applied in various ways to check their perpendicular, and to promote their lateral growth. But this point, which can only be gained upon a plain by art, is obtained upon a declivity by nature. There a tree loses its tendency to shoot upwards, and in order to preserve its branches parallel with the surface, is constrained to put them in a lateral direction.

Hence an important rule in the choice of orchards and fruit-gardens.

No. VII.

LIST of PEARS from Mr VAN MONS, Brussels, young Trees of which are still preserved in the Leith Walk and Broughton Nurseries.

(Referred to at p. 314.)

1. Grafted by Messrs DICKSONS and Co. Leith Walk, 16th April 1818.

Canning.	Capiaumont.
Avant fleur.	Bourbon du Roi.
Parmentier.	Augustine.
Beurré Royal	Du Hamel.
Hardenpont de printems (or Beurré Rance).	Carels d'hiver.
Ma Belle.	Wurtemberg.
Colmars.	Hæghens d'hiver.
Doré de printems.	Inconnue Lille.
Marie Louise.	Wurzer d'automne.
Bouvier d'automne.	Jaminette.
Darimont.	Decain d'hiver.
Adan.	Noir chair.
	Bellotte.

2. Grafted by Messrs DICKSONS Brothers, Broughton, 16th April 1818.

Marechal d'hiver.	Cramoisine.
Incommunicable.	Passe Colmars.
Drapiez d'été.	Bonchretien fondant.
Chomel.	Coloma d'hiver.
Inconnue Argenteau.	Bonchretien du Rhin.
Napoleon.	Bergamotte Heems.
Paridaens d'hiver.	Knight d'hiver.
Sabine.	Salisbury.
Beaudelet.	Cadet de Vaux.
Bretagne Colmar.	Linden d'automne.
Neill.	Hardenpont d'hiver.
Delices d'Ardenpont.	

No. VIII.

*LIST of FRUIT-TREES, &c. cultivated in the Jardin des
Plantes in 1802. Communicated by Mr BLAIRIE.*

(Referred to at p. 388.)

Mulberry. MORUS.

MURIER à fruit noir.	MURIER à fruit blanc d'Espagne,
_____ rose d'Italie.	_____ plusieurs variétés.
_____ rouge de Ca-	_____ blanc.
_____ nada.	

Bramble. RUBUS.

RONCE des hayes, R. fruticosus.	RONCE grimpante, R. scandens.
_____ bleuâtre, R. cæsius.	_____ des Alpes, R. saxatilis.

Raspberry. RUBUS idæa.

FRAMBOISIER ordinaire rouge.	FRAMBOISIER de Canada, à 5
_____ à fruit blanc.	_____ feuilles.
_____ de Malte, ou de	_____ à fruit noir de
_____ deux saisons.	_____ Virginie, R. oc-
	_____ cidental.

Rose. ROSA.

Eglantier des hayes.	Eglantier pommifère.
----------------------	----------------------

Arbutus.

ARBOUSIER de Provence.	ARBOUSIER d'Irlande.
------------------------	----------------------

Vaccinium.

AIRELLE des bois, V. myrtillus, L.
_____ canneberge, V. oxycoccos.
_____ à feuilles de buis, V. vitis idæa.

CAPRIER epineux, Capparis spinosa.

Currant. RIBES.

GROSEILLIER à grappes, fruit	GROSEILLIER à fruit blanc, gro-
_____ rouge.	_____ seille perlée.
_____ à fruit blanc.	_____ à fruit noir, Cassis.
_____ à fruit couleur de	_____ d'Amérique, à
_____ chaire.	_____ fruit noir. R. flo-
_____ panaché.	_____ ridum, L.

Gooseberry.

- GROSEILLIER à gros fruit rouge, herissé du duvet.
 _____ à gros fruit verdâtre, feuilles luisantes.
 _____ à fruit blanc moyen, et à feuilles vernissées et glutantes.
 _____ à fruit moyen verdâtre, et à feuilles legerement velues.
 _____ à fruit moyen rouge, et à feuilles legerement velues.
 _____ à fruit moyen blanchâtre et à feuilles legerement velues.

- GROSEILLIER à gros fruit violet, herissé de courtes pointes roides, et à feuilles luisantes.
 _____ à fruit gros jaunâtre parsemé des pointes rares, et à feuilles luisantes.
 _____ à fruit gros oblong blanchâtre et à feuilles luisantes.
 _____ à gros fruit blanchâtre et à feuilles luisantes.
 _____ sauvage à petit fruit.
 _____ à gros fruit violet herissé de pointes roides et noires, et à feuilles luisantes.

VIGNE. *Vine.* Vitis.

- Morillon hâtif, Raisin précoce, ou de la Madeleine; Morillon commun, ou à feuilles blanches et farineuses, noir et blanc.
 Chasselas doré, ou Bar-sur-Aube, blanc; ou de Fontainebleau.
 _____ rouge.
 _____ musqué.
 Ciotat écarlat, ou raisin d'Austriche.
 Muscat blanc.
 _____ rouge.
 _____ violet.
 _____ noir.

- Muscat d'Alexandrie, ou passe longue musquée.
 Raisin de Maroc, ou d'Afrique, Maroquin, ou Barbarosse.
 Cornichon blanc.
 Bordelais ou Verjus; Bourdelas.
 Corinthe blanc.
 Corinthe blanc violet, Mussé de Perigord.
 Pineau noir de Perigord mussé.
 De Marseilles.
 De la Belgique.
 Aleatier de Florence, Ruffo.

Barberry.

- EPINE-VINETTE à gros fruit rouge.
 _____ à fruit blanc.
 _____ à fruit violet.

- Barberis.
 EPINE-VINETTE à larges feuilles.
 _____ de la Chine.
 _____ de Crete.

Olive. Olea.

- OLIVIER sauvage. OLIVIER cultivé, plusieurs variétés.

Jujube.

- JUJUBIER de Provence, *Rhamnus sativa*, (*Zizyphus vulgaris*.)

Cornus.

CORNOUILLER male, à petit fruit
rouge.
————— à gros fruit
rouge.

CORNOUILLER male, à gros fruit
jaune.

CERISIERS, 1^{re} Division, à *fruit en cœur.*

MERISIER à petit fruit rouge
oblong.

————— à fleur double.

————— à gros fruit noir.

GUIGNIER à fruit noir.

————— à petit fruit noir, Bi-
garrautier.

————— à gros fruit blanc.

————— à fruit rouge de fer,
ou de St Gilles.

GUIGNIER à gros fruit noir lui-
sant.

BIGARREAUTIER à gros fruit
rouge.

————— à gros fruit blanc.

————— à petit fruit hâtif
blanc.

————— à petit fruit rouge
hâtif.

————— commun, Belle de
Roamont, tip de cerise.

CERISIERS proprement dit, 2^{de} Division, à *fruit rond.*

CERISIER nain, à fruit rond
précoce.

————— hâtif.

————— commun, à fruit rond.

————— à fleur semi-double.

————— à fleur double.

————— à noyaux tendres.

————— à trochet, ou tres fertile

————— à la Toussaint, ou à la
St Martin, à bouquet.

————— Montmorency à gros
fruit, ou Gros gobet.

————— coulard de Kent, rose,
ou gobet à courte queue.

————— Montmorency.

————— à gros fruit rouge pale,
ou cerise de Villenes.

————— de Hollande coulard.

————— à fruit ambre, ou à
fruit blanc.

————— griotte.

————— à gros fruit noir, gros
cerise à ratafiat, ou ce-
rise à courte queue de
Provence.

————— à petit noir, petit ce-
rise à ratafiat.

Griottier de Portugal, Royale
Archiduc, Royale d'Hol-
lande, cerise Portugal, gri-
otte de Portugal.

Griottier d'Allemagne, griotte
de Chaux, gros cerise de
commun de St Maur.

Royal cherry duke, Royale hâ-
tive Duc de Mai, May Duke;
Royale tardive, Holman's
duke.

Cerise Guigne royale, cerise
nouvelle d'Angleterre.

————— nouvelle d'Angleterre.

Huinderia de Provence.

Cerise de la Palembret, ou dou-
cette, Belle de Choisy.

————— à feuille de saule, à feu-
ille de balsamine.

————— à feuille de pêcher, bon
fruit moyen noirâtre.

————— d'Angleterre à fruit hâtif.

Guigne.

————— variété.

Cerise de Varennes, ou Bigar-
reau de Septembre.

Cerise Marasque de Zara.
 Bigarreau couleur de chaire.
 Cerisier à feuille de pêcher, ou
 Diocletien.
 Cerise cornichon nain.
 — de quatre à la livre.

Cerise de Toussaint plus hâtif
 que l'espèce ordinaire.
 — merveilleuse.
 — pleureuse.
 — de Sibérie.

PRUNIER. *Plum.* Prunus.

Prune jaune hâtive de Cata-
 logne.
 — précoc de Tours.
 — grosse noire hâtive, ou
 gros noir de Montreuil,
 belle espèce.
 — gros damas de Tours.
 — damas violet.
 — petit damas blanc.
 — gros damas blanc.
 — damas rouge.
 — damas noir tardif.
 — damas musqué, prune
 Chypre, prune de Malte.
 — damas Drouet.
 — d'Italie.
 — damas de Mongeron.
 — damas de Septembre,
 prune de vacance.
 — de Monsieur.
 — de Monsieur hâtif.
 — royale de Tours.
 — cerisette de Chypre.
 — Suisse.
 — perdrigon blanc, ou Pru-
 nier panaché.
 — violet.
 — rouge.
 — Normand.
 — royale ordinaire rouge.
 — grosse Reine Claude, abri-
 cot verte, verte bonne.
 — petite Reine Claude, ou
 Dauphine.
 — à fleur semi-double.
 — abricotée blanche.
 — petite Mirabelle.
 — drap d'or, Mirabelle
 double.

Prune imperiale violette, ou
 Rognon d'ane, Bricette.
 — bricette petite.
 — imperiale violette à feu-
 illes panachées.
 — jacinthe.
 — Dame Aubert.
 — diaprée violette.
 — rouge, Roche-
 courbon.
 — blanche, jaune
 hâtive.
 — Koitche, 3 vars. de Metz.
 — imperatrice blanche.
 — Dame Aubert, grosse
 luisante.
 — ile verte.
 — St Catherine.
 — sans noyaux.
 — de Virginie blanche.
 — de Mirobalan, ou de Vir-
 ginie, prune cerise.
 — datte rouge, ou de la
 Rochecourbon.
 — qui fructifie deux fois l'an.
 — virginale à fruit rouge.
 — St Martin.
 — virginale à gros fruit
 blanc.
 — abricotée rouge.
 — damas d'Espagne.
 — perdrigon hâtif.
 — Reine Claude violette.
 — de St Martin rouge.
 — de Canada, à fruit rouge.
 — gros damas, ambre de
 Provence hâtif.
 — gros damas de Monge-
 ron rouge, Cerisette.

Prune perdrigon blanc panaché
 — de la Chine.
 — à fleur double.
 — fleur semi-double d'Hol-
 lande.
 — de Canada.
 — de Virginie.
 — impératrice violette, ou
 prunier d'Altesse.

Prune gros St Julien à feuille
 panachée de jaune.
 — petit St Julien.
 — abricot.
 — pêche des Chartreux.
 — de Jerusalem.
 — rognon d'ane.
 — cerisette.

ARRICOTIER. *Apricot.* *Prunus Armeniaca.*

Abricot précoce hâtif musqué.
 — blanc improprement.
 — commun, ou blanc.
 — Angoumois.
 — d'Hollande, ou Amand
 Aveline.
 — de Provence.
 — de Portugal.
 — violet.

Abricot alberge.
 — de Nancy, ou pêche.
 — gros abricot.
 — panaché.
 — noir, ou de Pape.
 — de Rome panaché.
 — albergier de Monga-
 met.

ASSIMINIER, *anona, Anona triloba.*

PLAQUEMINIER, caquier, *Diospyros kaki.*
 — d'Italie, *D. lotus.*
 — de Virginie, *D. Virginiana.*

Medlar. *Mespilus.*

NEFLIER des bois.
 — à gros fruit.
 — sans noyaux.

NEFLIER de Japon, toujours
 vert.

Azerole. *Mespilus.*

AZEROLIER blanc d'Italie.
 — de Provence.
 — de Levant.
 — de Maroc.

AZEROLIER de Canada.
 — gros d'Amerique.
 — Aubépine à gros
 fruit jaune.

ALISIER, Alouchier de Bourgogne, *Cratægus torminalis.*

GORMIER à fruit de pommes, } *Sorbus domestica.*
 — à fruit en poires, }

Apple. *Pyrus Malus.*

POMMIER Calville d'été blanc.
 — passe pomme rouge;
 — passe pomme d'au-
 tomne; pomme d'ou-
 tre passe: passe
 pomme blanche;

cousinette, ou cou-
 senotte.
POMMIER Calville blanc d'hiver.
 — Calville rouge; cœur
 de bœuf, ou Calville
 rouge Normand.
 — postophe d'été.

POMMIER postrophe d'hyver.
 Pomme violette.
 ——— gros faros.
 ——— petit faros.
 ——— fenouillet gris, pomme
 d'anis.
 ——— ——— rouge; bardin;
 courpendu de
 Quentin.
 ——— ——— jaune, drap d'or
 ——— vrai drap d'or de St
 Julien
 Pomme d'or; Golden pippin;
 Reinette d'Angleterre.
 Reinette dorée; reinette jaune
 tardive.
 ——— jaune hâtive.
 ——— blanche.
 ——— naine.
 ——— rouge.
 ——— de Bretagne.
 ——— grosse d'Angleterre.
 ou de Canada.
 ——— franche.
 ——— grise.
 ——— de Champagne.
 Le gros doux, ou Gros doux à
 trochet.
 Pigeonnet.
 Cœur de pigeon, Jerusalem;
 pigeon.
 Rambourg franc.
 d'hyver.
 Apis.
 — noir.
 Pomme noir.
 Gros apis; pomme Ruele.
 Petit apis; pomme étoilé.
 Nonpareille d'Angleterre.
 Haute bonté.
 Capendu rouge et gris.
 Pomme de glace transparente.
 ——— figue.
 ——— poire.
 ——— francata.
 ——— princease noble.
 ——— de Jardy.

Pomme de Malingre d'Angle-
 terre.
 ——— de glace rouge des
 Chartreux; Pomme
 concombre nouvelle
 espece de Chatinay.
 ——— violette; gros pomme
 noir d'Amérique.
 ——— de Jerusalem, ou gros
 pigeonnet.
 ——— calville blanc d'été.
 Passe pomme d'automne.
 Royale d'Angleterre.
 Reinette rousse, ou des carmes;
 ou reinette d'or.
 ——— rouge d'Hervy.
 ——— inconnus; taffas de
 Bruzelles, Carole.
 ——— ciergs d'hyver.
 ——— concombre des Char-
 treux.
 Belle Hervy des Chartreux.
 Pomme St Germain à cidre.
 ——— Bevangue.
 ——— douce morelle, ou peau
 de vache, gros fruit.
 ——— blanc mollet.
 ——— hautbois.
 ——— marin oufré.
 ——— écarlatine.
 ——— rouge bruyere.
 ——— le doux à Lagnes.
 ——— le doux éveque.
 ——— de sonnette.
 ——— de brebis.
 ——— de jaunet.
 ——— de douceclair.
 ——— de chaudiere.
 ——— d'Ozane.
 ——— de binet.
 ——— d'ozane.
 ——— de sorcette.
 ——— de Blongy.
 ——— de Gagoumme.
 ——— de bouteille.
 ——— de Renouvalet.

Pomme de Duriot.
 ——— de chaudiere.
 ——— de jaunet.
 ——— de douce claire.
 ——— de St Noier.

POIRIER. Pear. *Pyrus sativa.*

Petit muscat, ou sept en gueule
 Muscat royale.
 ——— Robert; poire de reine;
 poire d'ambre.
 ——— fleuri.
 ——— de Nancy, ou aurate.
 Jargonelle, ou bellissima.
 Poire de Madeleine; citron des
 carnes.
 Amire Jeannet; poire de St
 Jean, ou Archiduc d'été.
 Hâtiveau, petit muscat; poire
 St Henry.
 Gros hâtiveau de la forêt;
 chair à dame.
 Cuisse Madame.
 Bellissime d'automne; vermil-
 lon.
 Gros blanquet d'été, ou blan-
 quette.
 ——— ——— var. rond.
 Blanquette à longue queue.
 Petit blanquette; poire de perle.
 Epargne; beau présent; grosse
 cuisse Madame; St Samson.
 Tarquin.
 Ognonet, Archiduc d'été; amiré
 roux.
 Parfum d'Aôut.
 Salviati.
 Poire d'Ange.
 Bezy d'Hervey.
 Poire de Vitrier.
 Orange musqué.
 Orange rouge.
 Bourdon musqué.
 Poire de jardin.
 Orange d'hiver.
 Martin sire, ou Roneville.
 Rousselet d'hiver.

Pomme de Marinanfray.
 ——— doux vert.
 ——— Bussiard des Mars.
 ——— rivaidelle.
 ——— cœur d'ane.

Rousselet de Rheims.
 ——— hâtif; poire de
 Chypre; perdreau.
 Gros rousselet; roi d'été.
 Poire sans peau; fleur de
 Guigne.
 Martin sec.
 Rousseline.
 Ah, mon Dieu; poire d'amour.
 Fin-or d'été.
 Fin-or de Septembre, ou d'Or-
 leans.
 Chaire à dames.
 Poire d'œuf.
 Inconnue Cheneau; fondante
 de Brest, ou cassante de
 Brest.
 Cassolette friolet, Muscat vert;
 poire Tabridor, Leche-frion.
 Bergamotte d'été, ou Milan
 blanc, Milan de la
 Beauviere.
 ——— rouge chérie.
 ——— Suisse.
 ——— d'automne.
 ——— crasane.
 Verte longue.
 Bergamotte de Soulers; bonne
 de Soulers; berga-
 motte de Pasque.
 ——— d'hiver; mince variété
 de précédente.
 ——— d'Hollande; amoselle,
 bergamotte d'Alen-
 çon.
 ——— Cadelle; poire de Ca-
 delle.
 Mesire Jean d'or; gris blanc.
 Robine royale d'été, mauvais
 fruit.

Epine rose; poire de rose; Cail-
lot rose de quelques jardi-
niers; poire tulipie de Mer-
let; poire d'eau rose; poire
de Malthe; poire de Merlet.

Double fleur.

Bezy de Quessay; roussette
d'Anjou; roussette de Bre-
tagne, Duhamel.

Franc real, ou gros micet.

Bequenne sauvageon à con-
serve.

Epine d'été; Bugiarda des Ita-
liens; la bonne poire de
Coni, fondante musquée.

Poire figue.

Epine d'hiver, bon fruit.

Ambrette d'été, ou grise bonne.

Echassery; bezy echassery.

Merveille d'hiver; petit oin.

Sucré vert.

Poire de prêtre.

Poire à Gobert, Gilogille, ou
garde écorce.

Royale d'hiver, ou Spina di
Carpa des Italiens.

Muscat d'Allemand, ou royale
d'hiver.

Verte longue, ou mouille
bouche.

— — — panachée, ou
poire Suisse; culote de
Suisse.

Beurré gris.

— d'Angleterre.

— d'Angleterre d'hiver.

Bezy Chaumontel; beurré d'hy-
ver.

Orange tulipée; poire aux
mouches.

Bellissime d'été supreme.

Doyenné blanc; beurré blanc;
St Michel, bonne ente.

Bezy Lamotte.

— de Montigny.

Doyenné blanc.

Franchipane.

Jalousie.

Bon Chrétien d'hiver.

Angelique de Bourdeaux.

Bon Chrétien d'Espagne.

— — — d'été, Gracioli.

Mansuette, ou solitaire.

Bon Chrétien musqué d'été.

Marquise.

Colmar; poire manne.

Virgouleux.

St Germain; inconnue de Fare.

Louise bonne.

Imperiale à feuilles de chene.

St Augustin.

Pastorale, ou musette d'au-
tomne.

Champriche d'Italie.

Catillac.

Bellissime d'hiver.

Poire de livre, Rateau gris.

Trefour d'amour.

Poire de Tonneau.

— de Naples.

Angelique de Rome.

Poire de Lansac; Dauphine,
satin.

— de vigne, ou demoiselle.

— sanguinole.

Sapin.

Poire à deux têtes.

Grise bonne; poire de forêt;
crapaudine; ambrette d'été.

Donville, poire de Provence.

Chat brûlé; pucelle de Sain-
tonge.

St Pere, ou St Pair.

Trouvet; poire de Prince.

Sarazin.

Poire cramoisiere, ou cramoisie.

St Lezain, tres grosse poire.

Poire de St Francois.

Muscat Robert.

Bergamotte d'Angleterre.

Beurré Romain.

Poire de mon Dieu.

Bergamotte sylvange, native
des environs de Metz.

Burré rouge Isambert.
 Poire de Bourdeaux.
 — de Maruny.
 — à feuille de saule; *Pyrus salicifolia*.
 — d'azerole. *P. polverina*.
P. spectabilis.

Poire des champs.
 Bon Chrétien Turc.
 Poire de Pendar.
 Burré d'hyver, nouvelle espèce.
 Belle de Bruxelles des Char-
 treux.
 Poire d'amiral.
 — geradeux.

Pour le Poiré.

Pêche cœur rouge.
 Poire de chemin.
 de Gros-mesnil.
 de Berlin.
 Picard blanc.
 Romois.
 Sablonière.
 Bimart.
 Carisi blanc-gros.
 Grand Dauphin.
 Poire de Lion.
 de Couret.
 Picard rouge.
 Franqueville.

Poire de Buisson.
 de Rouget.
 de gros vert.
 de salade.
 de cheminal, ou des
 moutons.
 de rousset de Reviers.
 de cochon.
 de four.
 de plâtre.
 de Carcan.
 de Margot.
 de fer.

La sauvage.

Quince. Pyrus cydonia.

COIGNASSIER de Portugal.
 femelle, ou ordinaire.

COIGNASSIER male.

FIGUIER. *Fig. Ficus carica.*

Figue blanc, } à fruit rond.
 } à fruit allongé.
 — grosse blanche ronde.

Figue angelique.
 violette.

PECHER. *Peach.*

Avant pêche blanche.
 — rouge, ou de
 Troyes.
 Double de Troyes; petit mi-
 gnonne.
 Avant pêche jaune.
 Alberge jaune, ou Rossane.
 Madeleine.
 Pavie alberge; Persais d'An-
 goumois.
 Madeleine blanche.
 Bourdine.
 Madeleine rouge; Madleine
 de Courson.

Amygdalus Persica.

Pêche de Malthe.
 Véritable pourprée hâtive,
 grand fleur.
 Pourprée tardive.
 Grosse mignonne, ou véloutté.
 Pourprée hâtive vineuse.
 Bourdine; Narbonne; Bour-
 din.
 Chevreuse hâtive.
 Belle chevreuse.
 Véritable Chancellière à grand
 fleur.
 Chevreuse tardive, ou pourprée.

Pêche cerise ; brugnon cerise, Miller.
 Petite violette hâtive ; violette d'Angevillier.
 Petite violette tardive.
 Violette panachée ; violette marbrée ; brugnon d'Italie.
 Violette très tardive ; pêche noir ; brugnon brun.
 Brugnon violette, ou musquée.
 Jaune lisse.
 Bellegarde, ou galande.
 Admirable, Belle de Vitry.
 Admirable jaune ; abricottée ; grosse pêche jaune.
 Pavie jaune ; pavie Baillonne.
 Teton de Venus.
 Royale.
 Belle de Vitry ; Admirable tardive.
 Pavie rouge de pompone ; pavie monstrueux.
 Tiendoux.

Almond. Amygdalus.

AMANDIER commun, à petit fruit.
 à coque tendre.
 à noyau tendre, et amande amère.
 à petit fruit, et noyau tendre, Sultaine.

Pistacio-Nut.

PISTACHIER male.

Walnut.

NOYER ordinaire, *J. regia*.
 de jauge, *J. maxima*.
 de St Jean, *J. serotina*.
 à fruit en grappes, *J. racemosa*.
 noir, *J. nigra*.

NOISETTIER. *Hazel-Nut.*

Aveline de Provence à grand calice.

Nivette veloutée.
 Persique.
 Pêche de Pau.
 Pêche à fleur semi-double.
 Sanguinole ; Cardinale ; betterave ; drusette.
 Pêche nain.
 Pêche à fleur double, pour l'agrément.
 Pourprée tardive véritable.
 Jaune lisse ; Monfrin tardive.
 Monfrin.
 Belle beauté ; variété de grosse mignonne.
 Vineuse, ou fromentin.
 Madelaine à petit fleur.
 Incomparable en beauté.
 Cardinale de Fustemberg.
 Transparente ronde.
 Pêche excellente de la petite Saulsaye hâtive, rond et rouge.
 Pêche amande.

AMANDIER à gros fruit dont l'amande, est douce amande amère.
 à fruit amère.
 Amande pistache.
 Amandier satine.
 nain des Indes.

Pistachia.

PISTACHIER femelle.

Juglans.

NOYER pacannier, *J. olivæformis*.
 cendre, *J. cinerea*.
 à feuille de frêne, *J. fraxinifolia*.
 hyckeri, *J. compressa*.
 blanc, *J. alba*.

Corylus avellana.

No. IX.

DESCRIPTION of *Pinus Laricio*, taken by Mr DAVID DON, from the specimen in the General Jussieuan Arrangement, at the Jardin du Roi.

P. Laricio (Lamarck), foliis geminis prælongis patentibus, vaginis subintegræ, strobilis ovatis rectis subsolitariis : squamis depressis obsolete 4-angulis.

Arbor altit. 56 ped., pulcherrima, pyramidata, ad apicem attenuata, cortice badio integro et epidermide decidua squamosâ tecta. *Rami* 8-10 in verticillis digesti, breviores et densiores quam *Pinus sylvestris*. *Folia* gemina, numerosa, prælonga (6-7-uncialia), lenta, patentia, acicularia, semicylindræa, subtus lucida, supra canaliculata atque leviter striata, margine scabrè serrulata, apice mucrone corneo instructa, colore jucundè viridi. *Vagina* foliorum uncialis, subintegræ, argenteo-fuscæ, nitidæ. *Strobili* sessiles, ovati, horizontalitè porrecti, subsolitarii : squamis induratis, ligneis, cinereo-fuscis, apice cuneatis depressis, obsolete 4-angulis, spinâ umbonatâ minutâ durissimâ armatis.

This tree is totally distinct from all the varieties of *Pinus sylvestris*, with which, however, it in some respects agrees. The tree in the Arboretum on the buttes, is 30 feet high and 3 feet in circumference, and immediately beside it is growing *P. sylvestris*, or, as Professor Thouin calls it, *P. scotica*. The difference is at first sight very striking. *P. Laricio* is a much handsomer and finer tree, and is of a more pyramidal habit. Its branches are shorter and more regularly verticillate. Its leaves are a third longer, and of a lively green, with their sheaths nearly entire. Its cones are shorter, ovate and quite straight, with depressed scales; and its bark is finer and much more entire. The enlightened Professor of Agriculture informed us, that it is equally hardy with *P. sylvestris*, and that its wood is much more weighty and resinous, and consequently more compact, stronger, and more flexible, than that of *P. sylvestris*. It grows wild on the summits of the highest mountains in Corsica. It seems to bear cones very freely, which ripen nearly about the same time as those of *P. sylvestris*. The tree from which the above description was taken, stands near

the centre of the General Arrangement, was planted in 1784, and is now 56 feet high.

No. X.

NOTICES by Mr DAVID DON, of rare Plants in the Jardin du Roi, from memoranda taken in August 1821.

They were at this time building a new serre-chaude to receive a recent cargo of live plants from Cayenne, containing, among many new, several of Aublet's plants. The following were some of the most interesting. *Areca* sp. nova. *Panax quinquefolia*. *Guettarda*, an *racemosa*? *Bignonia* forsan *incarnata* *Aubl.* *Clusia* sp. nov. *Sagus* *Monphia*. *Eugenia* sp. nov. *Annona muricata*. *Carissa guyanensis*. *Caladium* sp. nov. *foliis amplis peltatis, caule arboreo.* *Coccus* sp. nov. *Mimosa* sp. nov. *Cratæva* sp. nov. *Melastomæ* plures. A var. of *Morus alba*, cultivated by the Chinese; leaves of delicate structure, and of a fine light green. *Myristica sebifera Swartz Prod.* quæ *Virola sebifera Aubl. Guyan.* *Myristica aromatica Lam.* two fine plants $2\frac{1}{2}$ feet high. *Artocarpus nucifera*, fine. *Artocarpus integrifolia*, and *incisa*, from 12 to 14 fine healthy trees, 3 to 4 feet high. *Piper* *Betel*. Besides a great many undetermined and possibly new plants, especially Palms to the amount of fifteen. They were in good order, a gardener having constantly attended to them during their voyage of eight months.

Among the old collection of Stove Plants, we saw two very fine specimens of *Barringtonia speciosa*. *Morus* sp. nov., *foliis palmatis 3-4-lobis, ex Chinâ.* *Caryophyllus aromaticus*, 8 feet high, the finest I have ever seen in cultivation. *Myristica sebifera*, 6 feet high. *Areca oleracea*. *Laurus cinnamomum*, two trees 8 feet high; and *Piper odoratissimum, foliis octonis elliptico-oblongis obtusis carnosis, quandò contritis odorem fragrantissimum spirantibus.*

On the bank allotted to Alpine Plants, and in the compartment where new species are first cultivated, the following appeared.

Hypericum perforato affine, *foliis latè linearibus obtusis, petalis ovali-oblongis: lateribus inæqualibus; altero obliquo crenato.*

Erodium lucidum, foliis radicalibus longè petiolatis interruptè bipinnatim sectis lucidis glabris: segmentis linearibus acutis, scapo nudo, floribus umbellatis roseis: nervis ramosis purpureis. 4.

Bupleurum spinosum, *Origanum siphillum*, *Centaurea conifera*, *Cistus fumana* et *lævipes*, *Anthyllis montana*, *Ballota lanata*.

In the General Arrangement.

Smilax mauritanica (Desf. Atlant.), foliis cordato-oblongis glabris dentato-gerrulatis: lateribus exsinuatis, carinâ cauleque aculeatâ. h.

—— *oblongata* (Swartz), foliis cordato-lanceolatis integerrimis, carinâ cauleque inermi. h. G.

—— *horrida* (Hort. Paris.), foliis cordatis integerrimis 7-nerviis: carinâ subinermi, caulo aculeis rectis sparsis armata. h.

Tritoma glauca (Jacq.) mediæ similis at duplò vel triplò major.

Allium flavum, umbellis globosis, perianthiis flavis oris coarctatis, caule erecto tereti, staminibus simplicibus.

Helonias viridis, *Ornithogalum longebracteatum* Jacq. *Sisyrinchium tenuifolium*.

Neottia æstivalis, foliis lanceolato-linearibus acutis, caule erecto pubescente, spicâ spiralitèr convolutâ, perianthiis cylindraceis; foliolis exterioribus erectis interiora superantibus; inferioribus 2 linearibus; supremo latiore, labello cuneato-oblongo retuso crenulato apice deflexo.

Spiranthis æstivales, *Richard*.

Neottia spiralis γ, *Willd. Sp. Pl.*

Daphne alpina, foliis lanceolatis mucronatis subtus sericeis, caule depresso divaricato.

Daphne altaica, foliis lanceolatis mucronatis glabris, caule erecto simpliciore.

Rumex Abyssinicus (Jacq.), foliis lanceolato-hastatis, caule erecto.

—— *crispulatus* (Mich.), planta pusilla; foliis lineari-oblongis crispatis, caule debili.

Salsola laniflora, altissima, et *arenaria*, *Waldst. et Kit. Hung.*
Iresine herbacea. *Achyranthes virgata*, fruticosa, rivinifolia, peregrina.

Plantago tenuiflora (Waldst. et Kit.), foliis lineari-subulatis
carnosis integerrimis glabris, spicis tenuifloris,
caule folioso.

———— *hirsuta*, foliis linearibus carnosis undique cum scapo
pubescentibus.

———— *Calyxhymenia aggregata et glabrifolia* (Ortega). Ex
Nova Hispania.

The collection of species of the genus *Fraxinus* is the most
extensive I have ever seen.

Fraxinus cinerea (Bosc.), foliolis lanceolatis distanter serra-
tis utrinque acuminatis subtus pubescentibus.

———— *americana*, foliolis latè ellipticis integerrimis glabris.

———— *longifolia* (Bosc), foliolis lanceolatis integris utrin-
que acuminatis subtus ramulisque pubescentibus.

———— *nigra* (Bosc), foliolis subrotundo-ovatis acumina-
tis integerrimis, cortice ram. junior. nigro-fusco.

———— *lentiscifolia*, foliolis minimis.

———— *heterophylla* (Vahl), foliis simplicibus ternatisve.

———— *pubescens* (Lam.), foliolis latè ellipticis, obtusè et
brevè acuminatis integerrimis serratisve subtus
petiolo ramulisque tomentosis.

———— *juglandifolia*, foliolis rhombeo-lanceolatis utrinque
acutis inæqualitè serratis glabris.

———— *microphylla* (Lam.), foliolis lanceolatis coriaceis
glabris argutè serratis apice longè cuspidatis.

———— *sambucifolia*, foliolis lanceolatis acuminatis serratis
rugoso-venosis subtus ad nervum pilosis basi ro-
tundatis.

———— *quadrangulata* (Mich.), foliolis ovali-oblongis acu-
tis undulatis crenulatis basi cordatis subtus ad
nervum pilosis, ramis tetragonis.

———— *platycarpa* (Mich.), foliolis ellipticis acutis crenu-
latis subtus ramulisque densè pubescentibus.

———— *pallida* (Bosc), foliolis ovatis longè cuspidatis ar-
gutè dentato-serratis utrinque ramulisque gla-
bris; terminali maximo basi subcordato.

———— *nana* (Duham.), ramis crassis confertis, foliolis
confertis angustè lanceolatis.

Salvia scabiosifolia (Link), foliis pinnatis; foliolis lanceola-
tis crenatis rugosis incanis. h. Flores cœrulei.

- Salvia argentea*, *ceratophylloides*, *Ægyptiaca*, *erosa*, *parva*; foliis sinuato-pinnatifidis.
- Hyssopus myrtifolius* facie *H. officinalis*, sed foliis latioribus ferè Myrti.
- Betonica alopecurus*, *L.* *Scrophularia altaica*, (*Willd.*)
- Physalis foetens* (Bonpl.) *Solanum triquetrum*, *radicans*, *crassifolium*, *corymbosum*, *villosum*, *laciniatum* *Hort. Kew*, *reclinatum* (*L'Her.*), foliis elongato-linearibus integerrimis glabris; inferioribus pinnatifidis; superioribus simplicibus, corymbo terminali sessile. ♀. *Flores* magni, cœrulei.
- Solanum diphyllum*, *retrofractum*.
- Cynanchum acutum*, *monspeliacum*, sp. distinctiss. foliis brevioribus, *erectum*, foliis cordatis glaucis.
- Asclepias Mexicana*, foliis linearibus, floribus roseis.
- Echinus nutans* *Cassini*, quæ *Carlina Echinus* *Marsch. & Bieberst.* et *Cirsium carlinoides* *Fischer*.
- Achillea pauciflora* *Lam.* est *Pyrethrum Achilleæ* *Willd.*; *A. sambucifolia* *Lam.* est *P. macrophyllum* *Willd.*—*Obs.* Lamarck must have been led to refer these two species to *Achillea*, merely from external appearance, as they possess a naked receptacle, and therefore justly belong to *Pyrethrum*. *Achillea lingulata*, *Waldst. et Kit.*
- Rubia cordifolia*, *Thunb.* *Reseda glauca*, foliis angustè linearibus simplicibus glaucis.
- Silene suffruticosa*, foliis lanceolatis tomentosis.
- Cistus fumana*, *thymifolius*, *lævipes*, *canariensis*.
- Gleditsia triacanthos* two varieties, *lævis*, *monosperma*, *ferox*; *macrocanthos*, *caspica*, et *sinensis*.
- Alnus maxima*, *A. cordata*, foliis cordatis planis glabris lucidis.
- Bryonia africana*, foliis profunde multifidis.
- Pistachia trifoliata*, *Atlantica* (*Desf.*)
- Amyris polygama*, 15 feet high in the open air. *Ebenus cretica*, *Juniperus Phœnicia*, *thurifera*; *lycia*, *oxycedrus*, *drupacea*, *prostrata*. *Ephedra altissima* (*Desf.*) *Abies* sp. nov., a very depressed bush, about 4 or 5 inches high, from Newfoundland: Can it possibly be a stunted variety of *Abies rubra*, which it resembles in leaves? *Acacia junibrissum*, 20 feet high, and 15 years old, now in full flower. *Quercus prasina* (*Bosc*), foliis oblongis serratis glaucis. *Q. Lusitanica* (*Bosc*), foliis pinnatifidis. *Q. æsculus* *L.*, foliis ovato-oblongis dentatis acuminatis supra lucidis opacis subtus tomentosis.

No. XI.

EXTRACTS from Mr HAY's Journal in Hampshire.

Having parted with my friends Messrs Neill and Macdonald at Brighton, I proceeded to Portsmouth, and arrived next day (Oct. 6.) at *Broadlands*, the seat of Lord Viscount Palmerstone.

The grounds here were laid out by the celebrated Brown. The river Tees, which passes through the park, has been much improved in some places by widening it, and by dressing the grounds along its banks. These are indeed very fine; the plantations on the more distant banks, in particular, having a remarkably good effect. Mr Brown, I think, has not been very happy in his choice of a situation for the garden and offices. They are placed very near to the house, and between it and the town of Rumsey, which is in the immediate vicinity.

There are here some remarkably large English elms: of one which I measured, the trunk was 11 feet 6 inches high from the ground, to where it separates into two enormous branches, which I estimated to be about 30 or 40 feet each in extent of good timber.

This garden is of considerable size. It is surrounded with a brick-wall, and divided by another into two equal parts. There are forcing-houses for grapes and pine-apples; and the pinery is very good. Mr George Watson, who has the charge of the gardens and plantations, is well informed in every branch of his profession. Mr Watson introduced me to Dr Latham, physician at Rumsey, who possesses a rich cabinet of natural history articles. As connected with my pursuits, he shewed me a portfolio of drawings made by himself of the best pears and apples which are cultivated in that part of the country. He has a garden attached to his house, and is curious in the cultivation of fruits. Mr Watson informed me that the pear called in Scotland the Swan-egg, is here commonly named the Muirfowl-egg. They are very distinct; and the muirfowl-egg produced on standard-trees is perhaps one of our very best Scottish pears.

We afterwards visited the *Church of Rumsey*, a large and ancient pile. On the east end of it, and on the top of an aisle

perhaps 80 feet from the ground, an old apple-tree is growing. Its roots have penetrated the wall, which partly ascends above it, and a little earth has been put around the lower part of it. It divides into two branches a little above the root; and each of these has been grafted with a different kind of fruit. One of the branches, which is 25 inches in circumference, is in a horizontal direction, and the other, 21 inches in circumference, is nearly perpendicular. When I saw it, it was destitute of leaves, and only one apple was hanging at the extremity of one of the branches. It has undergone no change in size or otherwise in the memory of the oldest inhabitant. In walking round the church, I was struck with the resemblance of its principal entry to the gate of Hougomont, by reason of numerous marks of its having at one time been the scene of similar warlike operations. Many of the inhabitants of Rumsey, who had been favourable to the cause of Charles I., had taken refuge in this church; and the Parliament's army, in order to dislodge them, battered the building with grape and large shot, in such a manner, that the front gate is still quite covered with impressions of the balls.

Oct. 7.—Mr Watson having procured a gig, we set out together for *Embley*, the seat of Freeman Heathcote, Esq. M. P. for the county of Hants. Although he has other fine seats in this county, he some years ago turned his attention peculiarly to the embellishment of this place. It is nearly connected with an extensive heath; and, indeed, nearly the whole grounds were originally covered with heath and furze, although he has now converted them into a delightful residence. The situation is well adapted for a place, the grounds having a gentle undulating surface, and a rivulet running through that part which now forms the lawn. In one of the hollows are a few large oaks, which were the only trees on the spot when the spirited proprietor commenced his operations. The house and garden are plain, but good. The gardener is a young man from Banffshire. He called my attention to the rose-strawberry from Aberdeen, which is here much esteemed, and often produces twice in the season. The plantations are laid out with great taste, and are very thriving. Mr Heathcote has planted to a great extent, and

is still going on. The walks or drives through the woods are already extensive, and are decorated on both sides with the finest evergreens, such as rhododendron, azalea, kalmia, Portugal laurel, laurel-bay, laurustinus, and arbutus. The quantity of plants of this kind, not only near the house, but on the sides of the walks leading through the woods, is very great; and the effect of these, interspersed through the plantations, is extremely beautiful, particularly in walking from the mansion-house to a neat small house with a tower in the centre, from which there is a fine distant view of New Forest. This is the residence of the butler, a very deserving person, and who evidently possesses considerable taste. After leaving the lawn, and entering the woods, the rhododendrons, arbutus, laurustinus, in full flower, with laurel-bay and Portugal laurel, form a most beautiful contrast with the dwarfish upright furze (*Ulex nanus*), and heath-bushes, which are here very common native plants.

At one extremity of the wood, and not far from the above mentioned tower, a small spot has been selected by the butler, on which, by his own industry, he has displayed, that his taste in gardening is as correct as his master's in planting: He has chosen a hollow piece of ground, which was once used for the manufacture of bricks; in the middle of this, he has formed a small pond, with a piece of rock-work in the centre, and from the top of the rock-work, a fountain throws the water in several directions, and to a considerable height. A curious petrified oak-root is placed at one end of the pond: the root is branched, and the whole seems to have been encrusted with a thin covering of flint. Opposite to the centre of the pond, there is a curve in the face of the bank, with water trickling down a piece of artificial rock; and on the top of the bank, a grotto has been formed with shells, pebbles, petrifications, &c. The plants cultivated in this small and sheltered spot, are very fine; and immediately on ascending the bank on the other side, the heath and furze again appear, producing an agreeable contrast. The *ride* or wide walk terminates at present at the butler's house, from which it is now extending in new plantations. The hedge-fences on this property are particularly well kept.

Mr Heathcote takes much pleasure in building on different parts of his grounds, neat and comfortable cottages for his

workmen. A gentleman walking with him one day, observed, that his improvements must cost him a deal of money, "Yea," was his reply; "but these are my hounds and horses." His example is in every respect worthy of being imitated by surrounding proprietors, who, like him, may happen to possess large tracts of improvable territory, in this fine county of Hants.

We next went to *Paultons*, the seat of Hans Sloane, Esq. The park is extensive, and the trees in it are large, and very numerous. Although, according to the gardener's report, he has cut down timber, in the course of the last twelve years, chiefly oak, to the value of L. 130,000 Sterling, yet the place still appears fully stocked with fine old wood. This place is almost surrounded by New Forest. The gardener, a native of Aberdeenshire, is an intelligent man; his pine-apples and all other things are in good order; he has raised a considerable quantity of seedling rhododendrons, the seed ripening freely at this place; and he has obtained in this way several new varieties, particularly one, which he esteems on account of its superior flower: its habit is considerably different from the common sorts: he is propagating it by layers. I got from him two specimens of white potato, which he recommended: one he calls the Bread-fruit, and the other the Isle of Wight. I have placed these under the care of Mr Stuart at Pinkie.

On our way through *New Forest* to Cuffnells, my attention was attracted by the remains of an old oak, which had been of very great dimensions, but was now much decayed, quite hollow within, and open on one side. There is only a small stripe of the bark, 8 or 10 inches broad, ascending from the bottom to the top of the decayed trunk; but this is swelling out, and supporting a vigorous branch, proceeding from it.

His present Majesty (George III.) on his way to Portsmouth, used to take particular notice of this ancient tree, and some years ago ordered it to be inclosed with a rail. Large tracts of this Forest are lying waste. The soil appears well adapted for oaks, and being situated so near Portsmouth, it must be considered a national loss, that so much valuable land should remain in its present state, without being planted with young oaks, or sown with acorns. The necessity of inclosing the spaces so planted or sown, must be the chief ob-

stake: the expence would necessarily be great, but the return would be sure, though distant; and her wooden walls ought always to be considered, under Providence, as the bulwark of Britain.

Cuffnells, the seat of the late Right Honourable George Rose, is situated in New Forest. It was almost dark before we reached this place, and we therefore got but an imperfect view of it. The trees, principally large oaks, are very fine. We had only day light enough to examine an admirable rhododendron, standing on a lawn near the shrubbery; its branches, all close, and proceeding from one root, covered a space of ground 27 feet in diameter: it was represented to me as being the largest and most beautiful plant of the kind in England. A plant of the weeping thorn, not above 4 feet 6 inches high, but covering a space 21 feet diameter, had likewise a very elegant appearance. I got a peep by candle light into the conservatory, which, with a library and intermediate antichamber, extends to a considerable length on the south of the mansion. The conservatory is spacious; the plants grow in a circular pit, and there are spaces at each end, with chairs and sofas for the accommodation of company: but the exterior appearance of this conservatory has been attended to, more than its proper adaptation to the culture of plants; they are placed too far from the light, and there being no roof-glass, they soon become much drawn, and require to be frequently replaced, to keep up the effect.

Having thus finished this day's excursion, Mr Watson and I returned the same evening to Broadlands.—Next morning (Oct. 8.) I proceeded to Winchester, where I met the Bath coach, which carried me to London.

I N D E X.

- ACACIAS**, fine, at Ghent, page 41.—near Paris, 356.
Aërides, culture of, at Malmaison, 404.—at Loddiges', 514.
Agriculture, Flemish, 32.—near Brussels, 315.—near Tournay, 336.—in Norinandy, 493.
Ailanthus glandulosa cultivated at Paris, 384.—hardiness of, 390.
Almonds, fresh, in Paris market, 489.
Almond-trees at Bruges, 31.—at Paris, 472.
Aloe, American, at Bruges, 27.—at Leyden, 157.—at Chiswick, in flower, 506.
Altringham carrot, 220. note.
Amadou tinder, 205.
American shrubs, or rosages, fine, near Ghent, 71.—inferior at Paris, 392.
Amsterdam, 212.—Plantagie, 213.—Botanic Garden, 214.—Jews' Quarter, 218.—Green-market, 219.—Fruit-market, 224.—Stadt-house, 228.—new church, 229.—Fish-market, 230.—Butter-market, 231.—Naval Yard, 232.—Hope's bank, 233.—Felix Meritis, & c. 234.—Exchange, 235.—Rasp-house, & c. 236.—Dutch ashes, 237.
Anagallis fruticosa, in flower-borders at Leyden, 160.—at Paris, 418.
Andrews' forcing-garden, Lambeth, 2.—quantity of pine-apples and grapes produced at, 484.
Angerstein's sjlenidd garden, 511.
Annual plants, rich collection of, at Jardin du Roi, 393.
Antwerp, 91.—cathedral, 92. & 112.—quays, 92.—green-market, 93.—ponton, 95.—citadel, 96.—paintings, 97.—Smetz' country-seat, 98.—remarkable vine in Placede Merv, 113.
Api, pomme de, ornamental in pots, 460.
Apples, recommended at Ghent, 46.—at Antwerp, 106.—at Rotterdam, 127.—at Haarlem, 174. & 202.—at Amsterdam, 225.—German, 226.—white Spanish and De Caux, 460.
Apple-trees, large, on dikes of Holland, 117. and 270.—dwarfish in request for Dutch villa gardens, 181.—collections of, at Paris, 459. & 472.—collections of new kinds sent to Edinburgh by M. Van Mons, 318.
Apricots, at Ghent, 45 & 521.—forced at Haarlem, 172. & 210.—at Breda, 266.—early kinds at Montreuil, 483.—in Paris market, 486.
Apricot-peach recommended, 363, 465. & 486.—apricot royal recommended, 472.
Apricot-trees, standards employed at Paris, 465.—kinds at the Chartreux nurseries, 472.—at Noisette's, 465.
Aquatic plants at Ghent, 41.—at Amsterdam, 218.—at Paris, 389.—at Rouen, 495.
Araucaria excelsa, at Kew, 77.—at Enghien, 326.—at Boursault's, Paris, 453.
Arbonijn trees of Holland, 126.
Archery much practised at Ghent, 88.—at Brussels, 280.
Aremberg, Duke of, 295.—town-garden at Brussels, 296.—fine seat at Enghien, 239.
Artichokes at Ghent, 47.—young ones much used at Paris, 348.
Asclepias tuberosa, beds of, at Antwerp, 110.—at Haarlem, 192.

- Ash-tree, flowering, remarkable specimen of, 153.
- Ashes, Dutch, use of, in agriculture, 33.—collecting of, at Amsterdam, 237.—use in horticulture, 238.
- Aubergine, or purple Melongena, 446.
- Avenues, at Scheveling, 146.—at Haarlem, 175.—at Utrecht, 245.—at Brussels, 280.—at Enghien, 322.—at Paris, 421.
- Aviary near Ghent, 78. & 83.—at M. Boursault's, 454.
- Asalea, new variety of, 68.
- Bagatelle, elegant villa of Comte d'Artois, 359.
- Barbe de capucin salad, at Ghent, 87.—at Paris, 368.
- Barns, large, of Holland, 259.—of Belgium, 315.
- Basella leaves used as spinage, 489.
- Bastille, site of the, 382.
- Batatas cultivated at Paris, 376. and 422.
- Battle of Waterloo, field of the, 284.
- Beau present pear of Ghent, 46.—same as epargne, 274.
- Beech, purple, remarkable one, near Antwerp, 106.
- Beech-hedge, interwoven and interarched, near Conti, 270.
- Beet, red, at Ghent, 47.—at Amsterdam, 222.—white, for spinage and chards, at Paris, 490.
- Belle Baucis peach, recommended, 462.
- Bergen-op-Zoom, 115.
- Beurré d'Ardenpont pear, recommended, 46.—beurré d'Arenberg, 321. and 462.
- Bird-market at Paris, 378.
- Birds, aquatic, in Holland, 259.
- Black Hamburg grapes, excellence of at London, 7. and 484.
- Blaikie, Mr Thomas, visit to, at Hennefont, 367.—his history as an ingenieur des jardins Anglais, 359.
- Bleachfields of Haarlem, 181.
- Bloemistries of Haarlem, 168, &c.
- Boerhaave's trees at Leyden, 152.
- Booksellers, agricultural and horticultural, at Ghent, 89.—at Amsterdam and Utrecht, 264.—at Paris, 468. note.
- Boompies of Rotterdam, 133. & 185.
- Boors of Holland, 117.
- Boredorfer apple recommended, 226.
- Bosc, M. Inspector of Luxembourg nurseries, 470.—his work on grapevines, 471.
- Botanical garden at Ghent, 38.—Leyden, 152.—Amsterdam, 213.—Brussels, 276.—Paris, 360, 384. & 441.—Rouen, 494.—London, 502.—Chelsea, 504.
- Bourbon orange-tree at Versailles, 411.
- Boursault's garden at Paris, 452.
- Breda, 265.—church, ib.—Kaperken's nursery-garden, 266.
- Bridges, ornamental, at the seat of Madame Vilain-Quatorze, 82, 83.—at Mr Smetz's near Antwerp, 99.—at Duc d'Arenberg's, Enghien, 322.
- Bridge of Amsterdam, 331.—of Neuilly, 356.
- Brighton, 500.
- Brizevents, utility of, 433.
- Broadlands, seat of Lord Palmerston, 557.
- Brown of Perth, his new roses, 529.
- Bruges, 23.—Green-market, &c. 24.—paintings, 25.—Bertrand's villa, ib.—garden of Capuchin friars, 30.—agriculture, &c. 32.
- Brunsvigia Josephina, 403.
- Brussels, 271.—the Park, 272.—vegetable and fruit markets, 274.—frog-market, 275.—botanic garden, 276.—Palace of Lacken, 277.—Duc d'Arenbergs, 295.—M. Danoot's garden, 298.—Professor Van Mons, 301.—paintings and museum, 305.—Pepiniere de la Fidelité, 307.
- Brussels sprouts, culture of, 293.
- Buck-wheat, uses of, 23.
- Bulbs, planting of, at Haarlem, 183.
- Bulbous-rooted plants, writers on the culture of,—Van Oosten, 198.—Vivier, ib.—Justice, 199.—Van Kampen, 200.—Kreps, 521.
- Bunias orientale cultivated, 422.
- Busses, fishing, of Holland, 117.
- Buttes or hillocks at Jardin du Roi, 441.
- Buzelars of Nicol, conjecture regarding, 386.

- Cabbage, native at Dover, 17.
 Cabarets of Flanders, 65.
 Cabinet, botanical, at Jardin des Plantes, 354.
 Caffe at Paris, 346.
 Calebase pear, at Bruges, 31.—at Utrecht, 254.
 Calvert's rose-nursery at Rouen, 497.
 Carnetta, varieties of, at London, 6. and 514.
 Canal from Ostend to Bruges, 22.—from Bruges to Ghent, 35.—from Rotterdam to the Hague, 139.—the Hague to Leyden, 150.—Leyden to Haarlem, 166.—Amsterdam to Utrecht, 240.
 Canals, head, or water-ways, of Holland filling up, 265.
 Caper-bush, 476.
 Canterbury, 13.—ancient mulberry-tree, ib.
 Capuchin friars, garden of, at Bruges, 30.
 Carrot, horn, at Ostend, 21.—excellent at Ghent, 86.—long carrot of Amsterdam, 220.
 Catacombs of Paris, 496.
 Catalpa trees, at Lambeth, 8.—at Mile-End, 10.—at Antwerp, 108.
 Caulet, kind of open cabbage, cultivated near Tournay, 336.
 Cauliflower, abundance of, in Holland, 129.—especially at Amsterdam, 220.
 Cedar of Lebanon, Jussieu's, 442.—fine trees at Chiswick, 506.
 Celeriac, at Amsterdam, 222.—at Utrecht, 251.—at Breda, 267.
 Cels's botanical nurseries at Paris, 417.
 Chamærops humilis, large specimens at Leyden, 154.—at Paris, 352.
 Champ de Mars, 420.
 Champs Elysées, 421.
 Chandler and Buckingham's nurseries, 6.
 Chartreux nurseries at Paris, 469.
 Chasselas, principal table-grape at Paris, 471.
 Chaumontel pear, 462.
 Chêneau pear at Bruges, 31.—called Fondante de Brest at Brussels, 374.
 Cherries at Paris, 465.—early ones produced at Montreuil, 433.
 Cherry-trees, culture of at Haarlem, 203.—near Paris, 396.—at Montreuil, 433.—at Luxembourg nurseries, 472.
 Cherry-tree, large-leaved or quatre à la livre, 416. and 465.
 Cherry orchards in Kent, 12.—planting of, in France, 465.—near Montmorency, 492.
 Chesnuts, constant sale of, at Paris, 345.
 Chesnut-trees, large, near St Germain, 364.—near Versailles, 465.
 Chiswick, gardens of, 506.
 Church, of St Peter, Ostend, 19.—of St Bavo, Ghent, 47.—Protestant at Ghent, 65.—of Notre Dame, Antwerp, 91.—Groote Kerk, Rotterdam, 125.—Scottish at Rotterdam, 127.—Cathedral of Haarlem, 206.—Amsterdam, 229.—Breda, 265.—of St Gudula, Brussels, 271.—Oratoire at Paris, 379.—Luthéran church, Paris, 449.
 Cider orchards in Normandy, 493.
 Cinnamon-tree, fine specimen of, at Ghent, 78.
 Clay houses and walls in Picardy, 341.—in Normandy, 493.
 Clover, Dutch, at Bruges, 33.—rich in Holland, 118.—seed might be saved in Scotland, 34.
 Cingels, or boulevarts, of Rotterdam, 122.—of Amsterdam, 212.
 Cobbea scandens, how cultivated at Paris, 344.
 Cockscomb, or celosia, fine varieties at Bruges, 29.
 Cock's, De, nurseries at Ghent, 43.—catalogue of his fruit-trees, 519.
 Colmars, passe, at Bruges, 31.—recommended, 462.
 Conservatory, large, at Mr Angerstein's, 511.
 Conti village, 270.
 Copes of chesnut and oak near Ghent, 58.
 Corsica pine recommended, 441.
 Coster's statue at Haarlem, 167.
 Covent Garden market, 2.—remarkable state of, in the end of July 1821, 484.—compared with the Marché des Innocens, 483.
 Crocuses, culture of, at Haarlem, 164.
 Crops, agricultural, in Flanders, 22.—in Artois and Picardy, 340.—in Normandy, 498.

- Cucumbers, culture of, in Holland, 129.—at Paris, 348.—forcing of, at Kew, 407.
- Guffels, seat of Mr. Rose, 361.
- Cypress, deciduous, fine specimens of, 72.
- Dabbias, at Bruges, 27.—at Oeydonck, 60., at Wetteren, 84.—very fine at Antwerp, 109.
- Date-plum or Diospyros, at Paris, 473.
- Datura arborea, at Brussels, 297.—common at Paris, 375.
- Delft, town of, 141.
- Desfontaines, Professor, 445.
- Deanardes' Agrostographic, 336.
- Dibble, remarkable one, employed near Ghent, 56.
- Dickson of Oeydon, 503.
- Dieppe, 422.
- Dikes of Holland, 116.—in some places covered with large fruit-trees, 260.
- Ditton Park, 509.
- Docriana et Amicitia Society at Amsterdam, 285.
- Dogs, draught, in Holland, 146.
- Dom of Utrecht, 253.
- Donois stocks at Paris, 459.
- Dover, 15.—Castle terraced garden, 16.—native plants, 16.
- Doyt-boats of Rotterdam, 124.
- DuRoi's Traité des Arbres fruitiers recommended, 468.
- Edging of heath, 74.—of Festuca glauca, 423.
- Edinburgh, neglect of trees for ornament at, 134.—want of a fruit and flower market, 377.—want of an exchange; collection of bearing fruit-trees, 459.
- Edens, Van, of Haarlem, 169.
- Edging's bulb-nurseries near Haarlem, 181.
- Elm, variegated, near Ghent, 55.—Dutch, 256.—remarks on the kinds cultivated, 538.—characters of British species, by Mr. Don, 539.
- Embly, seat of Mr. Heathcote, 558.
- Endive, at Ostend, 21.—at Ghent, 47.—at Paris, 347.—cultivation of, at Hoxton, London, 513.
- Enghien, 317.—Duc. d'Ansemburg's seat, 316.—the gardens, 316.—fine park, 322.—Parmentier's rich gardens, 326.—thunder-storm at, 329.
- Erasmus's statue at Rotterdam, 131.
- Exchange of Antwerp, 95.—of Rotterdam, 131.—of Amsterdam, 236.
- Farmers, Flemish, great activity of, 32.
- Felix Meritis Society of Amsterdam, 234.
- Fiaker, St., patron of gardeners, 414.
- Figs, round white, abundance of, at Paris in August, 499.
- Fig-trees at Lambeth Palace, 7.—at Dover, 17.—near Antwerp, 104.—at Argenteuil, 489.
- Filbert-bushes of Kent, 12.—at Montreuil, 425.
- Fish-market of the Hague, 149.—of Amsterdam, 236.
- Fishes, fresh-water, of the canals in the Low Countries, 55.—see, at Scheveling, 147.—at the Hague, 149.—at Amsterdam, 230.
- Flax, much cultivated in Holland, 118.
- Flora, festivals of, at Ghent, 52.
- Flower-market, at Ghent, 56.—at Paris, 375.—want of one at Edinburgh, 377.
- Fountainsbleau grape, or chausseau, 471.
- Foppen-pear used for drying, 191.
- Forcing-gardens at London:—Andrew's, 2.—Grange's, 512.—Smith's 515.—at Paris, 491.
- Forcing-pits at Enghien, 320.
- Forest-trees of Kent, 15.—of Soignés, 281.—of St Germaine, 369.
- Frankendale vine, at Ghent, 48.—remarkable one at Mr Angerstein's, 512.
- Fraxinus ornus, remarkable specimen of, 153.
- Frog-market at Brussels, 275.
- Frogmore, 509.
- Frost, severity of, at Paris, 327, and 418.
- Fruit-market of Ghent, 37.—of Rotterdam, 129. & 130.—Amsterdam, 225.—Brussels, 274.—Paris in September 1812, 456.—in August 1821, 483.—want of one at Edinburgh, 377.
- Fruit-trees, arranged collections of at Ghent, 41.—at Haarlem, 201.—at

- Paris, Jardin du Roi, 348. & 542.
 —Noisette's, 458.—excellent at the
 Chateaux, 470.—Roule, 480.
- Fruit-trees, large, on dikes of Holland,
 117. and 260.—ancient in Regent
 Murray's garden, Edinburgh, 226.
- Fuel, scarcity of; at Bruges, 35.—kind
 used in Holland, 236.
- Fulham, Bishop of London's garden
 at, 511.
- Gardens, private;—Lambeth Palace,
 7.—Dover Castle, 16.—Bertrand's
 at Bruges, 26.—Moulemester's near
 Ghent, 55.—Baron de Vroyeland's,
 59.—Hopomere's, 70.—Madame
 Vilain-Quatorze's, 75.—Smets's,
 near Antwerp, 97.—Van Schenen's,
 at Rotterdam, 121.—Dr Daalen's,
 122.—Schoorman's, 125.—at the
 House of the Wood, 143.—at Haar-
 lem Palace, 172.—Dr Van Marum's,
 189.—M. Willink's, 210.—Seter-
 veldt's, at Utrecht, 247.—Duc d'A-
 remberg's at Brussels, 296.—Da-
 noot's, at Brussels, 298.—Duc d'A-
 remberg's at Enghien, 318.—Far-
 mantier's, at Enghien, 325.—Sir
 Charles Stewart's at Paris, 344.—
 Duc d'Orleans, 451.—M. Bour-
 sault's, 452.—Comtesse de Vande's
 at London, 505.—Duke of Devon-
 shire's, Chiswick, 506.—the King's
 garden, Kew, 507.—Sir Joseph
 Banks's, Spring Grove, 508.—Lord
 Montagu's, Ditton Park, 509.—Bi-
 shop of London's, Fulham, 510.—
 Mr Angerstein's, Deptford, 511.
- botanical, at Ghent, 38.—at
 Leyden, 151.—Amsterdam, 213.—
 Utrecht, 243.—Brussels, 276.—
 Lille, 337.—Paris, 351, &c.—
 Rouen, 494.—London, 502.—Kew,
 507.
- public, at Rotterdam, 123.—
 at Paris, 370.—Tivoli, 380.—Beau-
 jon, 439.
- small, of Dutch citizens, at
 Rotterdam, 123. and 127.—near
 Leyden, 151.—near Amsterdam,
 213.
- market, at Bruges, 24.—at
 Brussels, 280.—at Paris, 356.—
 primeur gardens, 491.—at Hoxton,
 near London, 512.
- Gardeners, Flemish, at Bruges, 30.—
 at Ghent, 55. 70. and 79.—at Ant-
 werp, 192.—French, at Jardin des
 Plantes, 352.
- Gardening, Dutch style of, 263.—best
 remaining instances of the old, 247.
 —Flemish, near Ghent, 59. 70. and
 75.—French, at Paris, Versailles,
 &c. 370. and 407.
- Garten Magasin of Sickler recom-
 mended, 193.
- Gavelkind division of property at
 Ghent, 58.—effects of near Paris,
 365.
- German, St, town of, 355.—Palace
 of, 362.
- Ghent, 36.—green and fruit market,
 37. and 86.—botanic garden, 38.—
 De Cock's nurseries, 42.—Smedt's
 market garden, 47.—exhibition of
 paintings, 49.—Agricultural and Bo-
 tanical Society of, 51.—aspect of
 country around, 57.—Protestant
 church, 65.—flower market, 66.—
 butchers'-meat market, 68.
- Ginkgo-tree, large, at Mile-End, 9.—
 at Leyden, 159.
- Gobelins manufactory, 445.
- Gooseberries neglected at Paris, 466.
- Grafting, uncommon instances of, at
 Brussels, 310.—curious kind of, at
 Paris, 387.
- Grange at Hoxton, extensive cultiva-
 tor of fruits and vegetables, 512.
- Grapes, at London, 5. & 465.—at
 Amsterdam, 225.—Enghien, 220.
 —Luzarches, 342.—Paris, 348. &
 437.—none ripe at Paris in August,
 484.—cheap there during winter,
 485.
- Gravenstein apple recommended, 226.
- Greengage, finest plum in France, 486.
 —two varieties cultivated, 472.
- Greenhouses near Ghent, 56. 63. &
 75.—near Antwerp, 101.—at the
 Hague, 145.—Amsterdam, 215.—
 Utrecht, 243. & 250.—at Enghien,
 319.—at Jardin du Roi, 351.—at
 Malmaison, 399.—at Boursault's,
 453.—at Roule nurseries, 475.—
 at Kensington Gardens, 505.—

- Chiswick, 506.—Mr Angerstein's, 511.
- Green-market of Ostend, 20.—of Bruges, 23.—Ghent, 37.—Antwerp, 93.—Rotterdam, 128.—Leyden, 162.—Amsterdam, 219.—Brussels, 273. and 293.—of Paris, 346.—Marché des Innocens in August 1821, 489.
- Haarlem, 167.—statue of Coster, 168.—Van Eeden's bloemistries, 169.—palace garden, 171.—Kreps's bloemistry, 175., and nurseries, 200.—Elderling's bulb-nursery, 181.—Voorhelm's garden, 187.—Van Marum's museum, 188.—Teylerian Museum, 189.—Schneevogt's bloemistry, 190.—cathedral, 206.—private gardens, 210.
- Hague, The, 142.—the Mall, 143.—House in the Wood, 144.—Scheveling, 146.—fish-market, 149.—the Hoff, *ib.*
- Hampton Court gardens, 507.
- Hand-glasses, commodious structure of, at Jardin du Roi, 395.
- Haricots at Bruges, 24.—at Paris, 348.—at Montreuil, 434.
- Hedges kept ready-formed in Dutch nurseries, 204.—examples of different, in Jardin des plantes, 385.—of furze in Sussex, 501.
- Hemp, cultivated near Ghent, 85.—near Utrecht, 259.
- Herborists of Paris, 385.
- Hervy, M. director of Luxembourg nurseries, 470.—gives lectures there, 474.
- Hoe, large, with wheels, at Brussels, 297.—at Paris, 492.—large, without wheels, at Enghien, 327.
- Holland, appearance of the very low country from Delft steeple, 141.—soil of, 185. and 262.—subsoil, 187.—general aspect of, 261.
- Hop-plantations in Kent, 12.—near Brussels, 315.
- Hope's villa at Haarlem, 171.
- Hopsomere's villa near Ghent, 70.
- Horticultural works recommended,—German, 193.—Dutch, 264.—French, 468.
- Hot-houses, structure of, at Bruges, 28.—at Botanic Garden of Ghent, 42.—at Moelemeester's, near Ghent, 57.—at Oeydonck, 61.—Madame Vilain-Quatorze's, 75. and 80.—near Antwerp, 104.—Amsterdam, 215.—Utrecht, 243.—at Duc d'Arenberg's, Enghien, 325.—at Jardin du Roi, 350.—at Malmaison, 399.—at Boursault's, 453.—Rouen, 495.—at Kensington, 505.—Chiswick, 506.—Loddiges at Hackney, 514.
- Hougomont, 287.—garden at, 289.
- House in the Wood, 144.
- Hyacinths, culture of, 176.—essay on, by Kreps, 521.
- Hydrangea, blue, 122.
- Institute of France, 391.
- Invalids, Hospital of, at Paris, 420.
- Jardin des Plantes at Paris, 350.—large hot-house or Serre Buffon, 351.—large greenhouse, *ib.*—Botanical cabinet, 353.—specimens of soils, &c. 384.—Medical arrangement, 385.—agricultural school, &c. 386.—garden of Ceres and Chloris, 387.—of Pomona, 388.—aquatic plants, 389.—collection of shrubs, *ib.*—garden of Flora, 390.—botanical school, *ib.*—nursery quarters, 392.—general Jussieuan arrangement, 393.—arboretum on the buttes, 441.—dry-stove, 443.—bank for alpine plants, *ib.*—list of fruit-trees in 1802, 542.
- Jargonelle, English, its names on the Continent, 473.
- Jews of Amsterdam, 218.
- Judas-trees, at Leyden, 159.—at Versailles, 410.
- Jujube-tree, 476.
- Jussieu, Professor, 445.
- Justice's "Scots Gardener's Director," 199.—extracts from, 530.
- Jut-pear (or Yut-pear) recommended at Rotterdam, 127.—excellent at Breda, 266.
- Kampen, Van, treatise on hyacinths, 536.
- Kensington Gardens, 505.
- Kent, agriculture and general aspect of, 11.

- Kermis**, or fair of Rotterdam, 120. & 138.—of Amsterdam, 212. & 331.
- Kew Gardens**, 507.
- Kidney-beans**, abundance of, in Holland, 129.—in France, under the names of Haricots verts, 348. and Haricots blancs, 434.
- Kohl-rübe**, cultivation of, 267.
- Kraams**, or crames, of Holland, 120.
- Kreps and Company's bloemistry** at Haarlem, 175.—their fruit-tree nurseries, 200.
- Lacken**, palace of, 278.
- Lafitte's bank** at Paris, 456.
- Lambeth palace garden**, 7.
- Lamps**, street, of Rotterdam, 136.
- Land**, value of, in Holland, 205.
- Leeks**, mode of planting, at Bruges, 25.
- Leerne**, chateau of Baron Vroeylande at, 59.
- Lettuce**, kinds in Holland, 130.
- Leyden**, 151.—botanic garden, 152.—flowering-ash of Boerhaave, 153.—palm-tree of Clusius, 155.—environs of, 161.—green-market, 162.—University, 163.—explosion of gunpowder on Raperburg Canal, 165.
- Lille**, 337.—botanic garden, 338.—citadel, 389.
- Lilium superbum**, beds of, 70.
- Lime-tree**, ancient, at Brussels, 297.
- Linneus**, monument to, at Ghent, 36.—at Paris, destroyed, 442.
- Liquidambar tree**, large, at Antwerp, 108.
- Loddiges' rich collection** of exotic plants at Hackney, 514.
- London**.—Covent Garden market, 2. and 502.—Andrews' forcing garden, 2.—Phillips' exhibition of fruit-trees, 6.—Chandler and Buckingham's nurseries, 1b.—Lambeth palace garden, 7.—Mile-End nurseries, 9.—Portman nurseries, 501.—Horticultural Society, 503.—The Vinery, Hammersmith, 504.—Comtesse de Vande's garden at Bayswater, 505.—Kensington garden, 1b.—Grange's market-garden at Hoxton, 512.—Loddiges' exotic collection at Hackney, 514.—Smith's forcing garden at Dalston, 515.
- Loquat** cultivated at Paris, 454.
- Louvre galleries**, 438.
- Lutheran church** at Paris, 449.
- Luxembourg gardens**, 414.—collection of rose-trees, 415.—fruit-tree nurseries, 469.
- Maemaster**, a Scottish gardener settled in France, 478.
- Magnolia**, new hybridous, 10.—fine trees near Ghent, 71.—on the lawn at La Malmaison, 397.
- Mahaleb stocks** used for cherry-trees at Paris, 474.
- Maize** cultivated near Ghent, 85.
- Majauf strawberry** at Paris, 349.
- Malines**, city, 270.
- Mall of the Hague**, 143.—of Utrecht, 245.
- Malmaison**, 396.—tender trees on the lawn sheltered by wooden houses, 397.—orange-tree en plein vent, 398.—description of the great hot-houses, 399.
- Mangold-wurzel** cultivated near Lille, 336.
- Marché des Innocens** at Paris, 346.—aux fleurs, 371.
- Market-gardens** at Bruges, 24.—at Ghent, 47.—at Brussels, 280.—near Paris, 491.—near London, 508. and 512.
- Marquis, Professor**, at Rouen, 495.
- Marroniers**, or large-fruited chesnut-trees, 365.
- Marum, Dr Van**, at Haarlem, 188.
- Mastick-tree**, large, at Ghent, 39.
- Meadow**, grand, at Oeydonck, near Ghent, 60.
- Measures of land**, Dutch, English, and Scotch, 176.
- Medlar-trees**, near Vianen, 257.—near Brussels, 316.
- Melons**, culture of, at Bruges, 29.—near Antwerp, 103.—at Paris, 348.—abundance of, at Paris in August 1821, 487.
- Menagerie** at Jardin du Roi, 444.
- Millet**, cultivated at Bruges, 31.
- Mistletoe** on trees at St Germain, 364.
- Moelemeester's villa** near Ghent, 54.
- Money**, Dutch, denominations and value of, 234. note.

- Mons, Van, at Brussels, 301.—list of his pears existing at Edinburgh, 541.
- Montmartre, 441.
- Montmorency cherry recommended, 472.—orchards at Montmorency, 492.
- Montreuil peach-gardens, 424.—plan of one, 426.—Loriant's garden, 427.—Mozard's, 429.—his mode of training peach-trees, &c. 430.
- Monuments, French, collection of, 450.
- Moucaux, elegant villa of Duc d'Orleans, near Paris, 360. and 451.
- Mozard, John, cultivator at Montreuil, 429.—his mode of training peach-trees, 430.—his work on the culture of the peach-tree, 432.
- Mulberry-tree, ancient, at Canterbury, 13.—large, at Rotterdam, 123.—at Leyden, 162.
- Mummy, or grafting cement, 203.
- Museums, at Haarlem, 188.—at Brussels, 305.—magnificent, at Paris, 355.
- Mushroom-beds, Oldakers', 508.
- Navet, or French turnip, 348.
- Nectarines, or pêches lisses, at Paris, 349.—at Montreuil, 428.—early nectarine called Desprez, recommended, 463.
- Neriums, fine, in Flanders, 77.
- New Forest, Hampshire, 560.
- Newspapers, little circulation of, in Flanders, 89. and 113.
- Nigella cultivated as a garden-crop at Bruges, 31.
- Noisette's nurseries at Paris. 457.—his work on fruit-trees, 468.
- Noordwyck, rose-gardens of, 179.
- Nôtre, Le, his style of gardening at the Tuileries, 371.—at Versailles, 408.—Vaux-Praslin, the first place designed by him, 478.—his monument, 451.
- Nurseries, Chandler and Buckingham's, 6.—Thomson, Mile-End, 9.—De Cock's, Ghent, 43.—Van Casseles', Spaes' and De Wulf's, Ghent, 66, 67.—Kreps and Co. Haarlem, 200.—Lunteren, Utrecht, 254.—Kaperken, Breda, 266.—Van Mons, Brussels, 307.—Lacroix, Paris, 416.—Cels's, at Petit Mont Rouge, excellent, 418.—at Vitry, 447.—Noisette's at Paris, excellent, 457.—Chartreux or Luxembourg, 469.—of the Roule, 474.—Vaillet's, at Rouen, 496.—Calvert and Co.'s, Rouen, 497.—Jenkins's, New Road, London, 501.—the Vinery, Hammier-smith, 504.—at Fulham, 510.—at NewCross, 511.—Loddiges, at Hackney, 514.—Smith's, at Dalston, 515.
- Oak, weeping, at Amsterdam, 218.
- Oils, vegetable, plants cultivated for producing, 337. and 339.
- Olive-trees, 417.
- Onions at Ghent, 47.—silver-skinned at Paris, 348.
- Orache, garden, common in Paris market, 490.
- Orangery, summer, at Antwerp, 98.—at Enghien, excellent, 323.—at Versailles, 411.—at the Luxembourg, 415.—winter, at Brussels, 277.—at Enghien, 324.—at Versailles, 412.
- Orange-trees, collections of, at Bruges, 27.—at Oeydonek, 61.—at Antwerp, 98.—Brussels, 276. & 296.—at the Tuileries, 371.—at La Malmaison, fine, 398.—at Versailles, magnificent, 411.—at the Luxembourg, 415.—M. Boursault's, planted en pleine terre, 455.—large sale collection at Rouen, 496.
- Orchards, near Ghent, 58.—in Normandy, 494.
- Orleans, Duke of, his numerous country-seats, 451.
- Ostead, 19.—green-market, 20.—Fort Wellington, 21.
- Pacane walnut, 466.
- Paeonia, species and varieties of, at London, 7.
- Pagoda, near Ghent, 82.—near Antwerp, 99.
- Paintings, exhibition of, at Ghent, 49.—at Antwerp, 92. and 97.—at Amsterdam, 234.—at Brussels, 305.
- Palais Royal at Paris 343.
- Palm-tree of Clusius, at Leyden, 154.—palms at Utrecht garden, 244.—at Jardin des Plantes, 352.—at Loddiges', Hackney, 514.

- Palm-cabbage**, 423.
Papaw-tree, 77.
Paradise and Doucin stocks, 459.
Park, The, of Brussels, 272.
Paris, 343.—English Ambassador's garden, 344.—Palais Royal, 345.—cafés, 346.—supply of vegetables, 347. and 483.—fruit, 349.—Jardin du Roi, 350. 383. and 441.—Tuileries palace, 360.—flower-market, 375.—Halle au blé, 380.—Tivoli gardens, 381.—Bastille, 382.—Institute, 391.—Luxembourg, 414.—garden of Cels, 417.—Hospital of Invalids, 420.—Champ de Mars, ib.—Vilmorin's garden and shop, 421. & 446.—catacombs, 469.—Louvre, 438.—Jardin Beaujon, 439.—Theatre Française, 440.—Montreuil, 441.—Gobelins, 445.—Lutheran church, 449.—Monumens Français, 450.—garden of Mouceaux, 451.—garden of M. Boursault, 452.—fruit in September 1817, 456.—in August 1821, 463.—Noisette's nurseries, 457.—Chartreux nurseries, 468.—Roule nurseries, 475.
Parmentier's fine garden at Enghien, 325.
Parsley, native at Dover Cliffs, 18.—Hamburgh, or large-rooted, common at Amsterdam, 223.
Passe-Colmars pear at Bruges, 31.—at Tournay, 334.—at Paris, 462.
Passiflora edulis, 507.
Paultons, seat of Mr Sloane, 560.
Pavilion at Brighton, 500.
Pea, early, at Ghent, 86.—Nanterre, 356.—mange-tout, 469.
Peaches, at Ghent, 44.—new variety, 68.—at Amsterdam, 224.—at Brussels, 299.—at Enghien, 321.—at Paris, 349.—Montreuil, 425.—Vitry, 448.—Noisette's, 462.—Roule nurseries, 477.—excellence of, in Paris market, in August 1821, 467.
Peach-garden, plan of one, at Montreuil, 426.
 ——— houses, at Bruges, 24.—near Ghent, 56.—at Wettering, 78.—Antwerp, 103.—Haarlem, 174.—economical placing of trees in, 463. at Kensington, 505.
Peach-trees, training, &c. at Montreuil, 427.—at Vitry, 447.—Roule nurseries, 477.—mode of training young trees by Sieuille, 479.
Pears recommended at Bruges, 31.—at Ghent, 45.—Antwerp, 105.—Rotterdam, 127.—Haarlem, 188. and 202.—Amsterdam, 224.—Utrecht, 255.—Brussels, 274. and 299.—new varieties of Van Mons, 303. and 541.—at Enghien, 321.—Tournay, 324.—St Germain-en-Laye, 364.—at Noisette's, 461.
Pear-tree cions, list of, sent to Edinburgh by M. Van Mons, 312. and 541.
Picardy, general aspect of, 340.
Pimento-trees, fine, at Ghent, 42. and 78.
Pine-apples, culture of, at London, 3. and 484.—at Bruges, 29.—Haarlem, 174. and 191.—Paris, 454.
Pinus tribe, rich collection of, at Parmentier's, Enghien, 328.—at Buttes of Jardin du Roi, 442.
Plane-trees, or platani, at Bruges, 24.—near Ghent, 56.—general mortality of, in 1814, 205.
Plantage of Amsterdam, 212.
Plants, native, notices of some, in Kent, 11.—at Dover, 18.—at Ostend, 20.—Bruges, 34.—canal between Bruges and Ghent, 35.—Ghent, 55. & 70.—near Williamstadt, 118.—Haarlem, 181.—on the sandhills there, 208.—near Amsterdam, 242.—Utrecht, 259.—Breda, 268.—Brussels, 273.—Soigné Forest, 283.—near St Germain, 363. and 369.—on the site of the Bastille, 383.—on Hill of St Catherine, Rouen, 498.—rare exotic, at Ghent, 53.—at Oeydonck, 60.—Haarlem, 192.—Amsterdam, 214.—at Duc d'Arenberg's, 319.—Parmentier's, 326.—at the Jardin des Plantes, 350. 369. and 550.—Malmaison, 398.—at Cels's, 417.—Boursault's, 453.—Noisette's, 467.
Plough, Flemish, 64.—French, 493.
Plums, at Ghent, 45.—at Antwerp, 106.—Brussels, 274.—at Paris, 465. and 486.

- Polyanthus-narcissus**, culture of, at Haarlem, 183.
Pomegranates, double-flowered, 371. and 417.
Poppies, field-culture of, near Enghien, 332.—near Lille, 336.—at Arras, 340.
Portman nurseries, London, 501.
Potato, early red kidney, at Bruges, 23.—at Antwerp, 94.—at Paris, 489.
Powdrette, uses of, 367.
Post-wegen, or diligence, of Holland, 115. and 119.
Protestants of Paris, 379.
Purslane, at Ostend, 21.—Bruges, 24. Amsterdam, 222.
Pyramidal fruit-trees at Bruges, 28.—Haarlem, 201.—Paris, 386.
Queenouille trees, at Bruges, 28.—Haarlem, 201.—Paris, 386.—slightly distinguished from pyramidal, *ib.*
Radish, kinds of, at Antwerp, 94.—at Paris, 489.
Rape, cultivated at Bruges, 32.—mode of planting in Normandy, 498.
Raspberries forced at Haarlem, 173.
Reeds, uses of, in Holland, 140. and 240.
Restaurateurs of Paris, 345.
Rhamnus sempervirens, 419.
Rhine, course of the, through Holland, 164.
 ——— barges, 132.
Ringling of peach-trees, 481.—of walnut-trees, 489.
Rosages, or American plants, 392.
Roses, collections of, at Ghent, 41.—at the Luxembourg, 415.—at Noissette's, 467.—at Calvert's, Rouen, 497.—Brown's, Perth,
 ——— culture of, for economical purposes, at Noordwyck, 179.—near Paris, 396.
Rotterdam, cleanliness of, 120.—Van Schenen's and Dr Daalen's gardens, 121.—the Singel, 123.—Groote Kerk, 125.—Schuurman's villa, *ib.*—Scottish church, 127.—vegetable market, 128.—fruit-shops, 129.—exchange, 131.—statue of Erasmus, 132.—Boompries, 133.—Bath hotel, 135.—Schouwburgh, 136.—sledges, 137.—kermis shows, 138.
Rouen, 494.—botanic garden, 495.—Vallet's nursery, 496.—Calvert's, 497.—Hill of St Catherine, 498.
Roule nurseries, 475.—management of the peach-espalier at, 477.
Rousselet de Rheims pear, recommended, 461.
Royer, M. of the Administration of the Jardin du Roi, 444.
Rumsey in Hants, 557.
Salicetum at Leyden, 158.
Samphire, rock, at Dover, 16.
Sandflood, means used for restraining the, 22. and 148.
Savoy-cabbages, culture of, 186.
Scheveling, fishing-town, 146.
Schneevogt's bloemistry, Haarlem, 180.
Scythe, Hainault, 290.
Sea-cale yet unknown in Paris market, 491.
Seeds of culinary plants, saving of, at Bruges, 25.—Ghent, 46.—Haarlem, 175.—Paris, 421.—best shop for procuring, 446.
 ——— of flowers, saving of, at Paris, 354. and 421.
Service-tree cultivated near Paris, 364.
Seterveldt's villa in the ancient Dutch style, 249.
Shells, depots of, in Holland, for laying walks, 264.
Shepherds of Picardy, primitive appearance of, 341.
Shrubs, remarkable, near Ghent, 73. and 83.—at Leyden, 152. and 157.—Utrecht, 244.—Brussels, 277.—Enghien, 329.—Jardin des Plantes, 389.—Malsmaison, 397.—at Cels's, 418.—M. Boursault's, 452.—Roule nurseries, 476.—Botanic garden of Rouen, 495.
Siculle's mode of training young peach-trees, 478.
Sledges, Dutch, 137.
Smetz the banker's place, near Antwerp, 97.
Society, Agricultural and Botanical of Ghent, 51.—of St Fiaker at Versailles, 414.—Horticultural of London, 503.

- Soigné Forest**, 281.
Sophora Japonica, weeping variety of, — 481.
Spring Grove, seat of Sir Joseph Banks, 508.
Spurrey, cultivated at Bruges, 32.—near Breda, 268.
Stadt-House of Amsterdam, 228.
Steam, employment of, for heating hot-houses, 4. 505. and 507.—advantages of, 4. and 508.
Stocks for fruit-trees, kinds used at Paris, 474.—at London, 502.
Storks in Holland, 117. and 166.—tame ones in the fish-markets, 149.
Strawberry, forcing of, at London, 5. and 513.—native, cultivated in Holland, 211.—alpine at Paris, 349.
Succory, cultivation and uses of, at Bruges, 29.—Ghent, 87.—St Germain, 367.—different varieties of, 387.
Succulent plants, collection of, at Leyden, 157.—at Amsterdam, 217.—at Jardin du Roi, 443.
Sugar-canes at Jardin des Plantes, 351.
Sumach-tree, large, at Brussels, 296.
Sunday, observance of, at Ostend, 19. Ghent, 69.—Brussels, 273.—Paris, 450.
Sylva-pear recommended, 364. and 462.
Tamus elephantipes at Amsterdam, 213.
Tapis vert at Versailles, 408.
Terraces, magnificent, at the Tuilleries, 371.—at St Germain, 362.—at Versailles, 410.
Teylerian Museum, Haarlem, 189.
Theatre of Rotterdam, 136.—Français, 439.
Thouars, Du Petit, inspector of Roële nurseries, 475.—his writings on fruit-trees, 480.—in the Orchidea, 482.
Thouin, brothers, at Jardin des Plantes, 395.—Professor A. Thouin, 447.
Thunberg's plants at Amsterdam, 218.—at Utrecht, 245.—at Enghien, 319.
Thunderstorm, remarkable, at Enghien, 329.
Tivoli gardens at Paris, 380.
Tobacco cultivated near Enghien, 332.—abundantly in Artois, 340.
Tournay, 333.—pear-tree gardens, 334.
Training of young fruit-trees, different modes of, in Holland, 201.—in France, 386.
Trapa natans at Versailles, 407.
Treckschuyts of Holland, 139.
Trees, remarkable, at Lambeth Palace, 8.—at Mile-End, 9.—at Canterbury, 14.—near Ghent, 55. 72. and 84.—at Antwerp, 106. & 108. the Hague, 144.—Leyden, 153. & 159.—Amsterdam, 218.—at Mont St Jean, 284.—Brussels, 296. 297.—near St Germain, 365.—near Paris, 424.—at Jardin des Plantes, 442.—at Roule Nurseries, 480.—Ditton Park, 509.—Fulham, 511.
Trees employed in ornamenting towns, at Antwerp, 93.—at Rotterdam, 133.—the Hague, 143.
Trianon, Petit, 405.—Grand, 406.
Tulleries palace, 369.—garden, 370.
Tulips, culture of, at Haarlem, 177. and 195.—florists' divisions of, 196.
Tulip-trees, 72.—at Versailles, 414.
Turnips, as a field-crop, 32.—garden, of inferior quality in Holland, 162.
University of Leyden, 163.—of Utrecht, 245.
Utrecht, 243.—botanic garden, 244.—Academicum, 245.—Mall, 246.—Palace, ib.—Seterveldt's garden, in the old style, 247.—the Dome, 252.—Flora's-hof, 254.—observatory, 256.
Vallet's nurseries at Rouen, 496.
Vandes', Comtesse de, garden at Bayswater, 505.
Varin-lilac, history of, 495.
Variegated shrubs and trees, uncommon kinds of, 67. and 338.
Vegetables, culinary, notice of some varieties little known in Scotland, 466.
Verjus-grape, 417.
Versailles, 407.—tapis vert, 408.—remains of Le Nôtre's works, 409.

- grands eaux, 410.—collection of orange-trees, 411.—the Bourbon, 412.—jardin potager of Quintynie, 414.
- Vianen, village, 257.
- Vilain-Quatorze, Madame, fine seat of, 75.
- Villas, small, of Holland, 140.
- Vilmorin's nursery-garden at Paris, 421.—his extensive seed-warehouse, 446.
- Vine, remarkable, at Ghent, 67.—in Place Verte at Antwerp, 113.—at Amsterdam, 215.
- Vines, culture of, in the open air, at Canterbury, 14.—on the Castle bank at Dover, 16.—against walls at Bruges, 31.—at Ghent, 42.—at Oeydonck, 63.—at Antwerp, 113.—Rotterdam, 123.—Haarlem, 191.—Utrecht, 250. and 255.—Brussels, 300.—Enghien, 320.—at Clermont in Picardy, 342.—St Germain, 363.—near Paris, 463.—great collection of kinds at the Luxembourg nurseries, 471.—culture at Roule nurseries, 476.
- Vinerias, or grape-houses, at London, 5. and 485.—at Bruges, 28.—at Oeydonck, 62.—Wetteren, 79.—near Antwerp, 103.—at Brussels, 300.—economical planting in, 463.
- Vineyards, or vignobles, in Picardy, 342.—near St Denis, 343.—near St Germain, 358.—at Argenteuil, 366.—at Montreuil, 435.
- Vitry nurseries, 447.
- Voorhelm's bulb-nurseries at Haarlem, 107.
- Walker, Dr, on planting fruit-trees on slopes, 540.
- Walks, garden, laid with sand, 297.—with shells, 264.—with turf broken small, 161.—with pounded trap-tuff, 278.—wheel-hoes for cleaning, at Brussels, 297.—at Paris, 492.
- Walls, garden, at Montreuil, 424. & 427.—their coping, 432.
- Walnut-trees, at Canterbury, 15.—at Bruges, 24.—near Ghent, 55.—at Oeydonck, 59.—new variety recommended, 363.
- Water-cress cultivated near Paris, 490.
- Watering flower-borders and grassward, mode of, at Palais Royal, 345.—at the Luxembourg, 416.
- Waterloo, field of battle, 284.—village, 292.
- Waterworks at Versailles, 410.
- Weeping-willow, fine one at Ghent, 38.—remarkable variety of, there, 40.—and at Cels's, Paris, 419.
- Weeping trees; cherry, 41.—birch, 84.—oak, 218.—thorn, 226. note.—sophora, 481.
- Wellington-tree at Mont St Jean, 284.
- Weymouth pines, 58.
- Williamstadt, 116.
- Wilmot at Isleworth, 508.
- Windsor, 509.
- Wulf, M. De, amateur nurseryman at Ghent, 67.
- Yut, or jut, pear recommended, 127. and 266.
- Zuyder-Zee bar, mode of passing large vessels over the, 232.
- Ziest, Moravian settlement at, 251.



CORRIGENDA.

Page 3. line 18. *for pits read pots*

38. — 6. — Buonaparte *read* the French Government

134. Note — English Elm, *Ulmus campestris read* Dutch elm, U. major

253. line 15. — westward *read* eastward

321. — 1. — rages *read* ravages

359. — 13. — between Harfleur and *read* near Honfleur and opposite to

366. — 7. — gens d'armes *read* gardes de verdure

448. — 2. — pear-trees *read* apple-trees

DIRECTIONS TO THE BINDER.

- Plate I. Ancient Mulberry-tree at Canterbury, to front
p. 14.
- II. Plan of Hot-house of Madame Vilain XIV. to
front p. 80.
- III. Section of ditto, p. 81.
- IV. Chinese bridge, p. 82.
- V. Palm of Clusius, p. 156.
- VI. (or V*) Plan of Great Hot-houses at Malmaison,
to front p. 399.
- VII. (or VI*) Section of ditto, p. 400.



P. NEILL, Printer.



