

This is a reproduction of a library book that was digitized by Google as part of an ongoing effort to preserve the information in books and make it universally accessible.

Google™ books

<https://books.google.com>

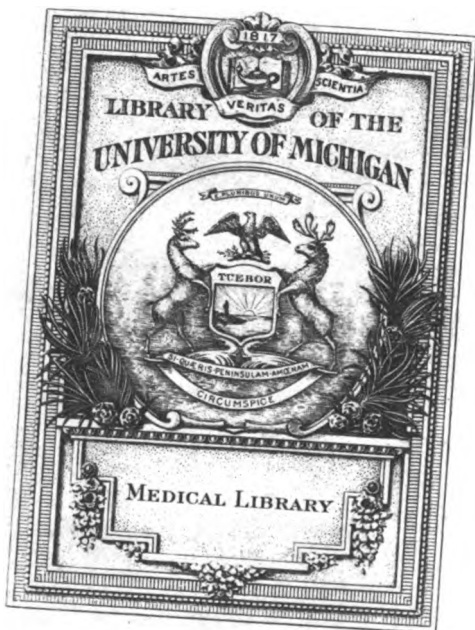





612
F76t
1878

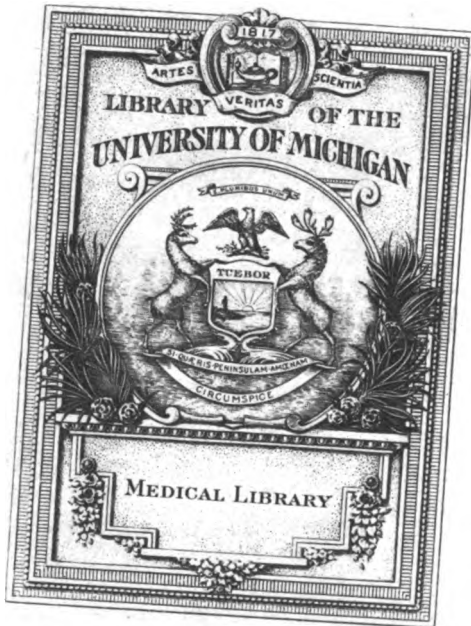

612
F76t
1878

A TEXT BOOK
OF
PHYSIOLOGY.



A TEXT BOOK



OF

PHYSIOLOGY

BY

11/2/88
M. FOSTER, M.A., M.D., F.R.S.,

PROFESSOR IN PHYSIOLOGY AND FELLOW OF TRINITY COLLEGE,
CAMBRIDGE.

WITH ILLUSTRATIONS.

SECOND EDITION, REVISED AND ENLARGED.

London:

MACMILLAN AND CO.

1878

[All Rights reserved.]

Cambridge:
PRINTED BY C. J. CLAY, M.A.
AT THE UNIVERSITY PRESS.

PREFACE TO THE SECOND EDITION.

So short a time has passed since the appearance of the first edition that it has not seemed desirable to make any important changes. My previous decision not to introduce figures of instruments has been so generally disapproved, that I have waived my own judgment and inserted a number of illustrations, which I trust will be found to assist the reader. The areas of the cerebral convolutions, in spite of the difficulties surrounding the true interpretation of the phenomena resulting from their stimulation, are of such interest, especially to the medical profession, that I have introduced illustrative figures for which I have to thank the kindness of Dr Ferrier.

Otherwise my efforts have been chiefly directed to removing inaccuracies and obscurities, in the hope of rendering the work more worthy of the favour with which it has been received. It will be observed that the largest changes and additions occur in the small print.

I have to thank Dr Pye-Smith and other friends as well as previously unknown correspondents for their valuable suggestions; and I am, as before, greatly indebted for the help given me by my former pupils, Mr Dew-Smith, Mr Langley, and Mr Lea.

TRINITY COLLEGE, CAMBRIDGE,
December, 1877.

ERRATA.

- p. 70, l. 6 from bottom, for *kilogrameters* read *grammeters*.
- p. 184, l. 11 from bottom, in the formula for dextrin for *O* read O_2 .
- p. 194, note 1, for *Lehrb.* i. 40 read *Lehrb.* p. 40.

CONTENTS.

	PAGE
INTRODUCTORY	1

BOOK I.

BLOOD. THE TISSUES OF MOVEMENT. THE VASCULAR MECHANISM.

CHAPTER I.

BLOOD, pp. 11—30.

Sec. 1. <i>The Chemical Composition of Blood</i>	12
Sec. 2. <i>The Coagulation of Blood</i>	14
Sec. 3. <i>The History of the Corpuscles</i>	27
Sec. 4. <i>The Quantity of Blood, and its distribution in the Body</i>	30

CHAPTER II.

THE CONTRACTILE TISSUES, pp. 32—84.

Sec. 1. <i>The Chemical Substances composing or present in Muscle</i>	32
Sec. 2. <i>The Phenomena of Muscle and Nerve</i>	35
The Phenomena of a simple muscular contraction, p. 36. Tetanic contractions, p. 44. Changes in a nerve during the passage of a nervous impulse, p. 46. Changes in a muscle during contraction, p. 52. The nature of the changes through which an electric current is able to generate a nervous impulse, Electrotonus, &c., p. 59. Circumstances affecting the amount and character of the contraction, p. 68.	
Sec. 3. <i>Unstriated Muscular Tissue</i>	82
Sec. 4. <i>Cardiac Muscles</i>	83
Sec. 5. <i>Cilia</i>	83
Sec. 6. <i>Migrating Cells</i>	84

CHAPTER III.

THE FUNDAMENTAL PROPERTIES OF NERVOUS TISSUES, pp. 85—95.

Automatic actions, p. 88. Reflex actions, p. 90. Inhibition, p. 93.

CHAPTER IV.

THE VASCULAR MECHANISM, pp. 96—179.

	PAGE
I. THE PHYSICAL PHENOMENA OF THE CIRCULATION	96
Sec. 1. <i>Main general facts of the Circulation</i>	97
The Capillary Circulation, p. 97. The flow in the Arteries, p. 99.	
The flow in the Veins, p. 106. Hydraulic principles of the Circulation, p. 107.	
Sec. 2. <i>The Heart</i>	113
The Phenomena of the Normal Beat, p. 113. The Mechanism of the Valves, p. 122. The sounds of the Heart, p. 126. The work done, p. 128. Variations in the Heart's Beat, p. 130.	
Sec. 3. <i>The Pulse</i>	131
II. THE VITAL PHENOMENA OF THE CIRCULATION	140
Sec. 4. <i>Changes in the Beat of the Heart</i>	141
Nervous mechanism of the beat, p. 142. Inhibition of the beat, p. 144. The effects on the circulation of changes in the heart's beat, p. 151.	
Sec. 5. <i>Changes in the calibre of the minute arteries. Vaso-motor actions</i>	154
Vaso-motor nerves, p. 155. Vaso-motor centre, p. 157. The effects of local vascular constriction or dilation, p. 170.	
Sec. 6. <i>Changes in the Capillary Districts</i>	171
Sec. 7. <i>Changes in the Quantity of Blood</i>	174
<i>The Mutual Relations and the Co-ordination of the Vascular Factors</i>	176

BOOK II.

THE TISSUES OF CHEMICAL ACTION WITH THEIR RESPECTIVE MECHANISMS. NUTRITION.

CHAPTER I.

THE TISSUES AND MECHANISMS OF DIGESTION, pp. 183—252.

Sec. 1. <i>The Properties of the Digestive Juices</i>	183
Saliva, p. 183. Gastric juice, p. 188. Bile, p. 195. Pancreatic juice, p. 198. Succus Entericus, p. 204.	
Sec. 2. <i>The act of secretion in the case of the Digestive Juices and the Nervous Mechanisms which regulate it</i>	205
Sec. 3. <i>The Muscular Mechanisms of Digestion</i>	224
Mastication, p. 225. Deglutition, p. 225. Peristaltic action of the small intestine, p. 227. Movements of the œsophagus, p. 230. Movements of the stomach, p. 232. Movements of the large intestine, p. 233. Defœcation, p. 233. Vomiting, p. 235.	
Sec. 4. <i>The Changes which the Food undergoes in the Alimentary Canal</i>	237
Sec. 5. <i>Absorption of the Products of Digestion</i>	244

CHAPTER II.

THE TISSUES AND MECHANISMS OF RESPIRATION, pp. 253—310.

	PAGE
Sec. 1. <i>The Mechanics of Pulmonary Respiration</i>	254
The Rhythm of Respiration, p. 256. The Respiratory Movements, p. 259.	
Sec. 2. <i>Changes of the Air in Respiration</i>	264
Sec. 3. <i>The Respiratory Changes in the Blood</i>	267
The relations of oxygen in the blood, p. 268. Hæmoglobin; its properties and derivatives, p. 271. Colour of venous and arterial blood, p. 276. The relations of the carbonic acid in the blood, p. 280. The relations of the nitrogen in the blood, p. 281.	
Sec. 4. <i>The Respiratory Changes in the Lungs</i>	281
The entrance of oxygen, p. 281. The exit of carbonic acid, p. 282.	
Sec. 5. <i>The Respiratory Changes in the Tissues</i>	284
Sec. 6. <i>The Nervous Mechanism of Respiration</i>	288
Sec. 7. <i>The Effects of Respiration on the Circulation</i>	295
Sec. 8. <i>The Effects of Changes in the Air breathed</i>	302
The effects of deficient air. Asphyxia. Phenomena of asphyxia, p. 302. The circulation in asphyxia, p. 304. The effects of an increased supply of air. Apnœa, p. 306. The effects of changes in the com- position of the air breathed, p. 307. The effects of changes in the pressure of the air breathed, p. 308.	
Sec. 9. <i>Modified Respiratory Movements</i>	308
Sighing, Yawning, Hiccough, Sobbing, Coughing, Sneezing and Laughter, p. 309.	

CHAPTER III.

SECRETION BY THE SKIN, pp. 311—316.

<i>The Nature and Amount of Perspiration</i>	311
<i>Cutaneous Respiration</i>	313
<i>The Secretion of Sweat</i>	314
The Nervous Mechanism of Perspiration, p. 315.	
<i>Absorption by the Skin</i>	316

CHAPTER IV.

SECRETION BY THE KIDNEYS, pp. 317—329.

Sec. 1. <i>The Composition of Urine</i>	317
Sec. 2. <i>The Secretion of Urine</i>	320
The relation of the secretion of urine to arterial pressure, p. 321. Secretion by the renal epithelium, p. 324.	
Sec. 3. <i>Micturition</i>	327

CHAPTER V.

THE METABOLIC PHENOMENA OF THE BODY, pp. 330—386.

	PAGE
Sec. 1. <i>Metabolic Tissues</i>	330
The History of Glycogen, p. 330. The History of Fat. Adipose Tissue, p. 340. The Mammary Gland, p. 344. The Spleen, p. 346.	
Sec. 2. <i>The History of Urea and its allies</i>	348
Sec. 3. <i>The Statistics of Nutrition</i>	355
Composition of the animal Body, p. 355. The starving Body, p. 356. The Normal Diet, p. 357. Comparisons of Income and Outcome, p. 358. Nitrogenous Metabolism, p. 361. The effects of Fatty or Amyloid Food, p. 363.	
Sec. 4. <i>The Energy of the Body</i>	366
The income of energy, p. 366. The expenditure, p. 368. The sources of Muscular Energy, p. 368. The Sources and Distribution of Heat, p. 372.	
Sec. 5. <i>The Influence of the Nervous System on Nutrition</i>	381
Sec. 6. <i>Dietetics</i>	383

BOOK III.

THE CENTRAL NERVOUS SYSTEM AND ITS INSTRUMENTS.

CHAPTER I.

SENSORY NERVES, pp. 389—396.

CHAPTER II.

SIGHT, pp. 397—448.

Sec. 1. <i>Dioptric Mechanisms</i>	397
The Formation of the Image, p. 397. Accommodation, p. 399. Movements of the Pupil, p. 405. Imperfections in the Dioptric apparatus, p. 410.	
Sec. 2. <i>Visual Sensations</i>	413
Simple Sensations, p. 416. Colour Sensations, p. 420.	
Sec. 3. <i>Visual Perceptions</i>	427
Modified Perceptions, p. 432.	
Sec. 4. <i>Binocular Vision</i>	436
Corresponding or identical points, p. 436. Movements of the eyeballs, p. 437. The Horopter, p. 442.	
Sec. 5. <i>Visual Judgments</i>	444
Sec. 6. <i>The protective Mechanisms of the eye</i>	447

CHAPTER III.

HEARING, SMELL, AND TASTE, pp. 449—461.

	PAGE
Sec. 1. <i>Hearing</i>	449
The acoustic apparatus, p. 449. Auditory Sensations, p. 452. Auditory Judgments, p. 457.	
Sec. 2. <i>Smell</i>	458
Sec. 3. <i>Taste</i>	460

CHAPTER IV.

FEELING AND TOUCH, pp. 462—470.

Sec. 1. <i>General Sensibility and Tactile Perceptions</i>	462
Sec. 2. <i>Tactile Sensations</i>	463
Sensations of Pressure, p. 463. Sensations of Temperature, p. 464.	
Sec. 3. <i>Tactile Perceptions and Judgments</i>	466
Sec. 4. <i>The Muscular Sense</i>	468

CHAPTER V.

THE SPINAL CORD, pp. 471—488.

Sec. 1. <i>As a centre of Reflex Action</i>	471
In the Frog, p. 471. In the Mammal, p. 476. The time of Reflex Actions, p. 478.	
Sec. 2. <i>As a Centre or Group of Centres of Automatic Action</i>	478
Sec. 3. <i>As a Conductor of Afferent and Efferent Impulses</i>	480

CHAPTER VI.

THE BRAIN, pp. 489—526.

Sec. 1. <i>On the Phenomena exhibited by an animal deprived of its Cerebral Hemispheres</i>	489
Sec. 2. <i>The Mechanisms of Co-ordinated Movements</i>	493
Forced Movements, p. 498.	
Sec. 3. <i>The Functions of the Cerebral Convolution</i>	500
Sec. 4. <i>The Functions of other parts of the Brain</i>	509
Corpora striata and optic thalami, p. 510. Corpora quadrigemina, p. 514. Cerebellum, p. 517. Pons Varolii and Crura Cerebri, p. 519. Medulla oblongata, p. 520.	
Sec. 5. <i>The Rapidity of Cerebral Operations</i>	521
Sec. 6. <i>The Cranial Nerves</i>	523

CHAPTER VII.

SPECIAL MUSCULAR MECHANISMS, pp. 527—538.

	PAGE
Sec. 1. <i>The Voice</i>	527
Sec. 2. <i>Speech</i>	532
Vowels, p. 532. Consonants, p. 533.	
Sec. 3. <i>Locomotor Mechanisms</i>	536

BOOK IV.

THE TISSUES AND MECHANISMS OF REPRODUCTION.

CHAPTER I.

MENSTRUATION, pp. 542—544.

CHAPTER II.

IMPREGNATION, pp. 545, 546.

CHAPTER III.

THE NUTRITION OF THE EMBRYO, pp. 547—552.

CHAPTER IV.

PARTURITION, pp. 553—555.

CHAPTER V.

THE PHASES OF LIFE, pp. 556—566.

CHAPTER VI.

DEATH, pp. 567, 568.

APPENDIX.

ON THE CHEMICAL BASIS OF THE ANIMAL BODY, pp. 571—626.

INDEX, pp. 627—640.

INTRODUCTORY.

AMONG the simpler organisms known to Biologists, perhaps the most simple as well as the most common is that which has received the name of *Amœba*. There are many varieties of *Amœba*, and probably many of the forms which have been described are, in reality, merely amœbiform phases in the lives of certain animals or plants; but they all possess the same general characters. Closely resembling the white corpuscles of vertebrate blood, they are wholly or almost wholly composed of undifferentiated protoplasm, in the midst of which lies a nucleus, though this is sometimes absent. In many a distinction may be observed between a more solid external layer or *ectosarc*, and a more fluid granular interior or *endosarc*; but in others even this primary differentiation is wanting. By means of a continually occurring flux of its protoplasmic substance, the amœba is enabled from moment to moment not only to change its form but also to shift its position. By flowing round the substances which it meets, it, in a way, swallows them; and having digested and absorbed such parts as are suitable for food, ejects or rather flows away from the useless remnants¹. It thus lives, moves, eats, grows, and after a time dies, having been during its whole life hardly anything more than a minute lump of protoplasm. Hence to the Physiologist it is of the greatest interest, since in its life the problems of physiology are reduced to their simplest forms.

Now the study of an amœba, with the help of knowledge gained by the examination of more complex bodies, enables us to state that the undifferentiated protoplasm of which its body is so largely composed possesses certain fundamental vital properties.

1. It is **contractile**. There can be little doubt that the changes in the protoplasm of an amœba which bring about its peculiar 'amœboid' movements, are identical in their fundamental nature with those which occurring in a muscle cause a contraction; a muscular contraction is essentially a regular, an amœboid movement an irregular flow of protoplasm. The body of the amœba may therefore be said to be contractile.

¹ Huxley and Martin, *Elementary Biology*, Lesson III.

2. It is **irritable** and **automatic**. When any disturbance, such as contact with a foreign body, is brought to bear on the amœba at rest, movements result. These are not passive movements, the effects of the push or pull of the disturbing body and therefore proportionate to the force employed to cause them, but active manifestations of the contractility of the protoplasm; that is to say, the disturbing cause, or 'stimulus,' sets free a certain amount of energy previously latent in the protoplasm, and the energy set free takes on the form of movement. Any living matter which, when acted on by a stimulus, thus suffers an explosion of energy, is said to be 'irritable.' The irritability may, as in the amœba, lead to movement; but in some cases no movement follows the application of the stimulus to irritable matter, the energy set free by the explosion taking on some other form (heat, &c.) than movement. Thus a substance may be irritable and yet not contractile, though contractility is the most common manifestation of irritability.

X The amœba (except in its prolonged quiescent stage) is rarely at rest. It is almost continually in motion. The movements cannot always be referred to changes in surrounding circumstances acting as stimuli; in many cases the energy is set free in consequence of internal changes, and the movements which result are called spontaneous or automatic¹ movements. We may therefore speak of the protoplasm of the amœba as being irritable and automatic.

3. It is **receptive** and **assimilative**. Certain substances serving as food are received into the body of the amœba, and being there in large measure dissolved, become part and parcel of the body of the amœba, become in fact fresh protoplasm.

4. It is **metabolic**² and **secretory**. *Pari passu* with the reception of new material, there is going on an ejection of old material, for the increase of the amœba by the addition of food is not indefinite. In other words, the protoplasm is continually undergoing chemical change (metabolism), room being made for the new protoplasm by the breaking up of the old protoplasm into products which are cast out of the body and got rid of. These products of metabolic action have in all probability subsidiary uses. Some of them, for instance, we have reason to think are of value for the purpose of dissolving and effecting other preliminary changes in the raw food mechanically introduced into the body of the amœba; and hence are retained within the protoplasm for some little time. Such products are generally spoken of as 'secretions.' Others which pass more rapidly away

¹ This word has recently acquired a meaning almost exactly opposite to that which it originally bore, and an automatic action is now by many understood to mean nothing more than an action produced by some machinery or other. In this work I use it in the older sense, as denoting an action of a body, the causes of which appear to lie in the body itself. It seems preferable to 'spontaneous,' inasmuch as it does not necessarily carry with it the idea of irregularity, and bears no reference to a 'will.'

² This term was introduced by Schwann (1839). *Micros. Untersuch.* p. 229.

are generally called 'excretions.' The distinction between the two is an unimportant and frequently accidental one. The energy expended in the movements of the amœba is supplied by the chemical changes going on in the protoplasm, by the breaking up of bodies possessing much latent energy into bodies possessing less. Thus the metabolic changes which the food undergoes in passing through the protoplasm of the amœba (as distinguished from the undigested stuff mechanically lodged for a while in the body) are of three classes: those preparatory to and culminating in the conversion of the food into protoplasm, those concerned in the discharge of energy, and those tending to economise the immediate products of the second class of changes by rendering them more or less useful for the first.

5. It is **respiratory**. Taken as a whole, the metabolic changes are pre-eminently processes of oxidation. One article of food, *i. e.* one substance taken into the body, *viz.* oxygen, stands apart from all the rest, and one product of metabolism peculiarly associated with oxidation, *viz.* carbonic acid, stands also somewhat apart from all the rest. Hence the assumption of oxygen and the excretion of carbonic acid, together with such of the metabolic processes as are more especially oxidative, are frequently spoken of together as constituting the respiratory processes.

6. It is **reproductive**. The individual amœba represents a unit. This unit, after a longer or shorter life, having increased in size by the addition of new protoplasm in excess of that which it is continually using up, may, by fission (or by other means) resolve itself into two (or more) parts, each of which is capable of living as a fresh unit or individual.

Such are the fundamental vital qualities of the protoplasm of an amœba; all the facts of the life of an amœba are manifestations of these protoplasmic qualities in varied sequence and subordination.

The higher animals, we learn from morphological studies, may be regarded as groups of amœbæ peculiarly associated together. All the physiological phenomena of the higher animals are similarly the results of these fundamental qualities of protoplasm peculiarly associated together. The dominant principle of this association is the physiological division of labour corresponding to the morphological differentiation of structure. Were a larger or 'higher' animal to consist simply of a colony of undifferentiated amœbæ, one animal differing from another merely in the number of units making up the mass of its body, without any differences between the individual units, progress of function would be an impossibility. The accumulation of units would be a hindrance to welfare rather than a help. Hence, in the evolution of living beings through past times, it has come about that in the higher animals (and plants) certain groups of the constituent amœbiform units or cells have, in company with a change in structure, been set apart for the manifestation of certain

only of the fundamental properties of protoplasm, to the exclusion or at least to the complete subordination of the other properties.

These groups of cells, thus distinguished from each other at once by the differentiation of structure and by the more or less marked exclusiveness of function, receive the name of 'tissues.' Thus the units of one class are characterized by the exaltation of the contractility of their protoplasm, their automatism, metabolism and reproduction being kept in marked abeyance. These units constitute the so-called muscular tissue. Of another tissue, viz. the nervous, the marked features are irritability and automatism, with an almost complete absence of contractility and a great restriction of the other qualities. In a third group of units, the activity of the protoplasm is largely confined to the chemical changes of secretion, contractility and automatism (as manifested by movement) being either absent or existing to a very slight degree. Such a secreting tissue, consisting of epithelium-cells, forms the basis of the mucous membrane of the alimentary canal. In the kidney, the substances secreted by the cells being of no further use, are at once ejected from the body. Hence the renal tissue may be spoken of as excretory. In the epithelium-cells of the lungs, the protoplasm plays an altogether subordinate part in the assumption of oxygen and the excretion of carbonic acid. Still we may perhaps be permitted to speak of the pulmonary epithelium as a respiratory tissue.

In addition to these distinctly secretory or excretory tissues, there exist groups of cells specially reserved for the carrying on of chemical changes, the products of which are neither cast out of the body, nor collected in cavities for digestive or other uses. The work of these cells seems to be of an intermediate character; they are engaged either in elaborating the material of food that it may be the more easily assimilated, or in preparing used up material for final excretion. They receive their material from the blood and return their products back to the blood. They may be called the metabolic tissues *par excellence*. Such are the fat-cells of adipose tissue, the hepatic cells (as far as the work of the liver other than the secretion of bile is concerned), and in general the blood.

Each of the various units retains to a greater or less degree the power of reproducing itself, and the tissues generally are capable of regeneration in kind. But neither units nor tissues can reproduce other parts of the organism than themselves, much less the entire organism. For the reproduction of the complex individual, certain units are set apart in the form of ovary and testis. In these all the properties of protoplasm are distinctly subordinated to the work of growth.

Lastly, there are certain groups of units, certain tissues, which are of use to the body of which they form a part, not by reason of their manifesting any of the fundamental qualities of protoplasm, but on account of the physical and mechanical properties of certain substances which their protoplasm has been able by virtue of its metabolism to manufacture and to deposit. Such tissues are bone,

cartilage, connective tissue in large part, and the greater portion of the skin.

We may therefore consider the complex body of a higher animal as a compound of so many tissues, each tissue corresponding to one of the fundamental qualities of protoplasm, to the development of which it is specially devoted by the division of labour. It must however be remembered that there is a distinct limit to the division of labour. In each and every tissue, in addition to its leading quality, there are more or less pronounced remnants of all the other protoplasmic qualities. Thus, though we may call one tissue *par excellence* metabolic, all the tissues are to a greater or less extent metabolic. The energy of each, whatever be its particular mode, has its source in the breaking up of the protoplasm. Chemical changes, including the assumption of oxygen and the production complete or partial of carbonic acid and therefore also entailing a certain amount of secretion and excretion, must take place in each and every tissue. And so with all the other fundamental properties of protoplasm; even contractility, which for obvious mechanical reasons, is soonest reduced where not wanted, is present in many other tissues besides muscle. And it need hardly be said that each tissue retains the power of assimilation. However thoroughly the material of food be prepared by digestion and subsequent metabolic action, the last stages of its conversion into living protoplasm are effected directly and alone by the tissue of which it is about to form a part.

Bearing this qualification in mind, we may draw up a physiological classification of the body into the following fundamental tissues:—

1. The eminently contractile; the muscles.
2. " " irritable and automatic; the nervous system.
3. " " secretory, or excretory; digestive, urinary, and pulmonary &c., epithelium.
4. " " metabolic; fat-cells, hepatic cells, lymphatic and ductless glands, &c.
5. " " reproductive; ovary, testis.
6. The indifferent or mechanical; cartilage, bone, &c.

All these separate tissues, with their individual characters, are however but parts of one body; and in order that they may be true members working harmoniously for the good of the whole, and not isolated masses each serving its own ends only, they need to be bound together by co-ordinating bonds. Some means of communication must necessarily exist between them. In the mobile homogeneous body of the amoeba, no special means of communication are required. Simple diffusion is sufficient to make the material gained by one part common to the whole mass, and the native protoplasm is physiologically continuous, so that an explosion set up at any one point is immediately propagated throughout the

whole irritable substance. In the higher animals, the several tissues are separated by distances far too great for the slow process of diffusion to serve as a sufficient means of communication, and their primary physiological continuity is broken by their being imbedded in masses of formed material, the product of the indifferent tissues, which being devoid of irritability, present an effectual barrier to the propagation of molecular explosions. It thus becomes necessary that in the increasing complexity of animal forms, the process of differentiation should be accompanied by a corresponding integration, that the isolated tissues should be made a whole by bonds uniting them together. These bonds moreover must be of two kinds.

In the first place there must be a ready and rapid distribution and interchange of material. The contractile tissues must be abundantly supplied with material best adapted by previous elaboration for direct assimilation, and the waste products arising from their activity must be at once carried away to the metabolic or excretory tissues. And so with all the other tissues. There must be a free and speedy intercourse of material between each and all. This is at once and most easily effected by the regular circulation of a common fluid, the blood, into which all the elaborated food is discharged, from which each tissue seeks what it needs, and to which each returns that for which it has no longer any use. Such a circulation of fluid, being in large measure a mechanical matter, needs a machinery, and calls forth an expenditure of energy. The machinery is supplied by a special construction of the primary tissues, and the energy is arranged for by the presence among these of contractile and irritable matter. Thus to the fundamental tissues there is added, in the higher animals, a vascular bond in the shape of a mechanism of circulation.

In the second place, no less important than the interchange of material is the interchange of energy. In the *amœba* the irritable surface is physiologically continuous with the more internal protoplasm, while each and every part of the body has automatic powers. In the higher animal, portions only of the skin remain as eminently irritable or sensitive structures, while automatic actions are chiefly confined to a central mass of irritable or nervous matter. Both forms of irritable matter are separated by long tracts of indifferent material from those contractile tissues, through which they chiefly manifest the changes going on in themselves. Hence the necessity for long strands of eminently irritable tissue to connect the skin and contractile tissues as well with each other as with the automatic centres. Similar strands are also needed, though perhaps less urgently, to connect the other tissues with these and with each other. To the vascular bond there must be added an irritable bond, along the strands of which impulses, set up by changes in one or another part, may travel in determinate courses for the regulation of the energy of distant spots. In other words, part of the irritable tissues must be specially arranged to form a coordinating nervous system.

Still further complications have yet to be considered. In the life of a minute homogeneous amœba, possessing no special form or structure, there is little scope for purely mechanical operations. As however we trace out the gradual development of the more complex animal forms, we see coming forward into greater and greater prominence the arrangement of the tissues in definite ways to secure mechanical ends. Thus the entire body acquires particular shapes, and parts of the body are built up into mechanisms, the actions of which are to the advantage of the individual. Into the composition of these mechanisms or 'organs' the active fundamental tissues, as well as the passive or indifferent tissues, enter; and the working of each mechanism, the function of each organ, is dependent partly on the mechanical conditions offered by the passive elements, partly on the activity of the active elements. The vascular mechanism, of which we have just spoken, is such a mechanism. Similarly the urgent necessity for the access of oxygen to all parts of the body, has given rise to a complicated respiratory mechanism; and the needs of copious alimentation, to an alimentary or digestive mechanism.

Further, inasmuch as muscular movement is one of the chief ends, or the most important means to the chief ends of animal life, we find the animal body abounding in motor mechanisms, in which the prime mover is muscular contraction, while the machinery is supplied by complicated arrangements of muscles with such indifferent tissues as bone, cartilage, and tendon. In fact, the greater part of the animal body is a collection of muscular machines, some serving for locomotion, others for special manœuvres of particular members and parts, others as an assistance to the senses, and yet others for the production of voice, and in man, of speech.

Lastly, the simple automatism of the amœba, with its simple responses to external stimuli, is replaced in the higher animals by an exceedingly complex volition affected in multitudinous ways by influences from the world without; and there is a correspondingly complex central nervous system. And here we meet with a new form of differentiation unknown elsewhere. While the contractility of the amœbal protoplasm differs at the most but slightly from the contractility of the vertebrate striated muscle, there is an enormous difference between the simple irritability of the amœba and the complex action of the vertebrate nervous system. Excepting the nervous or irritable tissues, the fundamental tissues have in all animals exactly the same properties, being, it is true, more acute and perfect in one than in another, but remaining fundamentally the same. The elementary muscular fibre of a mammal is at most a mass of but slightly differentiated protoplasm, forming a whole physiologically continuous, and in no way constituting a mechanism. Each fibre is a counterpart of all others; and the muscle of one animal differs from that of another in such particulars only as are wholly subordinate. In the nervous tissues of the higher

animals, on the contrary, we find properties unknown to those of the lower ones, and in proportion as we ascend the scale, we observe an increasing differentiation of the nervous system into unlike parts. Thus we have, what does not exist in any other tissue, a mechanism of nervous tissue itself, a central nervous mechanism of complex structure and complex function, the complexity of which is due not primarily to any mechanical arrangements of its parts, but to the further differentiation of that fundamental quality of irritability and spontaneity which belongs to all irritable tissues, and to all native protoplasm.

In the following pages I propose to consider the facts of physiology very much according to the views which have been just sketched out. The fundamental properties of most of the elementary tissues will first be reviewed, and then the various special mechanisms. It will be found convenient to introduce early the account of the vascular mechanism, and of its nervous coordinating mechanism, while the mechanisms of respiration and alimentation will be best considered in connection with the respiratory and secretory tissues. The description of the purely motor mechanisms will be brief, and, save in a few instances, confined to a statement of general principles. The special functions of the central nervous system, including the senses, must of necessity be considered by themselves. The tissues and mechanism of reproduction naturally form the subject of the closing chapter.

BOOK I.

BLOOD. THE TISSUES OF MOVEMENT. THE
VASCULAR MECHANISM.

CHAPTER I.

BLOOD.

BLOOD is a tissue of which the corpuscles are the essential and active elements, while the plasma is a liquid matrix. It may be compared to a cartilage, the firm matrix of which has become liquefied, so that the cartilage-corpuscles are perfectly free to move about. Of the two kinds of corpuscles, the white, seeing that they alone exist in many invertebrata, must be regarded as the original and proper cellular elements. The red corpuscles are forms which have been specially modified for respiratory and other purposes. In regarding, however, blood as a tissue, we find that it differs from the other tissues in possessing no one characteristic property. The protoplasm of the white corpuscles is native undifferentiated protoplasm, in no respect fitted for any special duty; as far as we know at present, the white corpuscles are in reality embryonic structures concerned chiefly in the production of other forms, such as red corpuscles and, it may be, under certain conditions, various elements of the other tissues. The red corpuscles have a definite respiratory function; but these form a part only of the blood. The largest portion of the blood, the whole mass of the plasma, is an unorganized fluid with no proper physiological (vital) properties of its own. Its function is to serve as the great medium of exchange between all the tissues of the body. It, together with lymph (whether in the lymph-canals or in the interstices of the tissues), may, as Bernard has suggested, be regarded as an *internal medium* bearing the same relations to the constituent tissues that the external medium, the world, does to the whole individual. Just as the whole organism lives on the things around it, its air and its food, so the several tissues live on the complex fluid by which they are all bathed and which is to them their immediate air and food. Hence the composition and the characters of blood must be for ever varying in different parts of the body and at different times. The changes which blood is known to undergo in passing through the various tissues will best be dealt with when those tissues and organs are under consideration. At present it will be sufficient to treat of—1st, the general chemical composition of Blood; 2nd, the phenomena of its coagulation; 3rd, the history of its corpuscles; 4th, the total quantity of blood in the body.

SEC. 1. THE CHEMICAL COMPOSITION OF BLOOD.

Blood, within the living vessels, is a fluid; but when shed, or after the death of the vessels, becomes solid by the process known as coagulation. The average specific gravity of human blood is 1055, varying from 1045—1075 within the limits of health. It has an alkaline reaction, which in shed blood rapidly diminishes up to the onset of coagulation.

Blood may, in general terms, be considered as consisting by weight of more than one-third and less than one-half of corpuscles, the rest being plasma, the corpuscles being supposed to retain the amount of water proper to them.

Hoppe-Seyler gives, in 1000 parts of the venous blood of the horse, Corpuscles, 326, Plasma, 674; C. Schmidt¹, in human blood, Corpuscles, 513, Plasma, 487².

In coagulation, see Sec. 2, a substance called fibrin forms with the corpuscles the clot; and the plasma becomes, by the loss of the fibrin or fibrin-factors, converted into serum. The average quantity of fibrin in human blood is said to be .2 p. c., but the amount which can be obtained from a given quantity of plasma varies extremely; the variation being due not only to circumstances affecting the blood, but also to the method employed.

Since serum is nothing but blood-plasma deprived of its fibrin-factors, it will be best to consider the chemical composition of serum alone.

Composition of serum. In 100 parts of serum there are in round numbers

Water	90 parts
Proteid Substances	8 to 9 „
Fat, Extractive, and Saline Matters	2 to 1 „

Of the Proteid³ substances the great mass consists of the so-called serum-albumin, but there are present also small quantities of fibrinoplastin or fibrinoplastic globulin, which may be precipitated by passing a stream of carbonic acid through diluted serum, and of alkali albuminate or serum casein, which after removal of the globulin may be thrown down by dilute acetic acid, and which is totally devoid of fibrinoplastic powers.

The fats, which are scanty, except after a meal or in certain pathological conditions, are the neutral fats, stearin, palmitin, and olein, with a certain quantity of their respective alkaline soaps. Lecithin and cholesterin occur in very small quantities only. Among the extractives⁴ present in serum may be put down all the nitrogenous and other substances which form the extractives of the body and of food,

¹ *Characteristic der Cholera*, p. 3.

² For the various methods of determination see Hoppe-Seyler, *Hdb. Analyse*, p. 327.

³ For detailed accounts of the characters of the several chemical substances mentioned in this and succeeding chapters consult the Appendix under the appropriate headings.

⁴ This word is used to denote soluble substances of varied origin and nature, occurring in small quantities, and therefore requiring to be 'extracted' by special means.

such as urea, kreatin, sugar, lactic acid, &c. A very large number of these have been discovered in the blood under various circumstances, the consideration of which must be left for the present. The peculiar odour of blood-serum is probably due to the presence of volatile bodies of the fatty acid series. The faint yellow colour of serum is due to a special yellow pigment. The most characteristic and important chemical feature of the saline constitution of the serum is the preponderance of sodium salts over those of potassium. In this respect the serum offers a marked contrast to the corpuscles (see below). Less marked, but still striking, is the abundance of chlorides and the poverty of phosphates in the serum as compared with the corpuscles. The salts may in fact briefly be described as consisting chiefly of sodium chloride, with small quantities of sodium carbonate, sodium sulphate, sodium phosphate, calcium phosphate, and magnesium phosphate.

Composition of the red corpuscles. The corpuscles contain less water than the serum. In 100 parts of wet corpuscles there are of

Water	56·5	parts
Solids	43·5	"

The solids are almost entirely organic matter, the inorganic salts in the corpuscles amounting to less than 1 p. c. Of the organic matter again by far the larger part consists of hæmoglobin. In 100 parts of the dried organic matter of the corpuscles of human blood, Jüdel¹ found, as the mean of two observations,

Hæmoglobin	90·54.	Lecithin	4·54
Proteid Substances	8·67	Cholesterin	·25.

The composition and properties of hæmoglobin will be considered in connection with respiration. Of the proteid substances which form the stroma of the non-nucleated red corpuscles this much may be said, that they belong to the globulin family. The amount of fibrinoplastic globulin, and the exact nature of the other members of the group present, must be considered as yet undetermined. As regards the inorganic constituents, the corpuscles are distinguished by the relative abundance of the salts of potassium and of phosphates.

The distribution of inorganic salts in blood may be seen from the following analysis by C. Schmidt² of the ash of plasma and corpuscles respectively

In 1000 parts Corpuscles.	In 1000 parts Plasma.
Potassium chloride 3·679	Potassium chloride ·359
" sulphate ·132	" sulphate ·281
" phosphate 2·343	
Sodium " ·633	Sodium phosphate ·271
Calcium " ·094	Calcium " ·298
Magnesium " ·060	Magnesium " ·218
Soda ·341	Soda 1·532
	Sodium chloride 5·546
7·282	8·505

¹ Hoppe-Seyler, *Untersuch.* III. 390.

² *Op. cit.*

It must be remembered that the arrangement of bases and acids in such an analysis is an artificial one, and moreover, that the ash does not represent the inorganic salts present in a natural condition in the blood. Thus for instance, the phosphates in the ash are largely derived by oxidation from the phosphorus present in the lecithin, and the sulphates similarly from the sulphur of proteid substances. On the other hand, carbonic anhydride is absent from the above table, though carbonates undoubtedly exist in the serum. Free soda is put down as a constituent of the ash, because in the ash the bases preponderate over the acids (even when carbonic anhydride is reckoned with them); this alone shews how little the salts of the ash correspond to those really present in the blood. Among the natural saline constituents of serum may be enumerated sodium chloride, calcic phosphate, which is enabled to exist in a state of solution in the alkaline blood by reason of its being combined in some way or other with the proteids, and sodium carbonate.

Composition of the white corpuscles. If it be permitted to infer the composition of the white corpuscles from that of the pus-corpuscles which they so closely resemble, they would seem to consist of¹—

1. Several proteid substances, viz. ordinary albumin, an albumin like that of muscle coagulating at 48°, an alkali albumin, a substance closely resembling myosin and yet differing from it, and a peculiar form of proteid material soluble with difficulty in hydrochloric acid. The nuclei contain nuclein. See Appendix.

2. Lecithin, extractives, glycogen, and inorganic salts, there being in the ash a preponderance of potassium salts and of phosphates; after the death of the corpuscle the glycogen appears to be converted into sugar.

Both the corpuscles and the plasma (or serum) contain gases. These will be considered in connection with respiration.

The main facts of interest then in the chemical composition of the blood are as follows. The red corpuscles consist chiefly of hæmoglobin. The solids of serum consist chiefly of serum-albumin, the quantity of fibrin factors and of alkali albuminate being small. The serum or plasma contrasts with the corpuscles, inasmuch as the former contains chiefly chlorides and sodium salts while the latter are richer in phosphates and potassium salts. The extractives of the blood are remarkable rather for their number and variability than for their abundance, the most constant and important being perhaps urea, kreatin, sugar, and lactic acid.

SEC. 2. THE COAGULATION OF BLOOD.

Blood, when shed from the blood-vessels of a living body, is perfectly fluid. In a short time it becomes viscid; it flows less readily from vessel to vessel. The viscosity increases rapidly until the whole mass of blood under observation becomes a complete jelly. The vessel into which it has been shed, can at this stage be inverted without a drop of the blood being spilt. The jelly is of the same

¹ Miescher. Hoppe-Seyler, *Untersuchungen*, iv. 441.

bulk as the previously fluid blood, and if forcibly removed, presents a complete mould of the interior of the vessel. If the blood in this jelly stage be left untouched in a glass vessel, a few drops of an almost colourless fluid soon make their appearance on the surface of the jelly. Increasing in number, and running together, the drops after a while form a superficial layer of pale straw-coloured fluid. Later on, similar layers of the same fluid are seen at the sides and finally at the bottom of the jelly, which, shrunk to a smaller size and of firmer consistency, now forms a clot or *crassamentum*, floating in a perfectly fluid serum. The shrinking and condensation of the clot, and the corresponding increase of the serum, continue for some time. The upper surface of the clot is generally cupped. A portion of the clot examined under the microscope is seen to consist of a feltwork of fine granular fibrils, in the meshes of which are entangled the red and white corpuscles of the blood. In the serum nothing can be seen but a few stray corpuscles.

In man, blood when shed becomes viscid in about two or three minutes, and enters the jelly-stage in about five or ten minutes. After the lapse of another few minutes the first drops of serum are seen, and coagulation is generally complete in from one to several hours. The times however will be found to vary according to the condition of the individual, the temperature of the air, and the size and form of the vessel into which the blood is shed. Among animals the rapidity of coagulation varies exceedingly in different species. The blood of the horse coagulates with remarkable slowness; so slowly indeed that many of the red corpuscles (these are specifically heavier than the plasma) have time to sink before viscosity sets in. In consequence there appears on the surface of the blood an upper layer of colourless plasma, containing in its deeper portions many colourless corpuscles (which are lighter than the red). This layer clots like the other parts of the blood, forming the so-called 'buffy coat.' A similar buffy coat is sometimes seen in the blood of man, in inflammatory conditions of the body.

This buffy coat makes its appearance in horse's blood even at the ordinary temperature of the air. If a portion of horse's blood be surrounded by a cooling mixture of ice and salt, and thus kept at about 0° C., coagulation may be almost indefinitely postponed. Under these circumstances a more complete descent of the corpuscles takes place, and a considerable quantity of colourless transparent plasma free from blood-corpuscles may be obtained. A portion of this plasma removed from the freezing mixture clots exactly as does the entire blood. It first becomes viscid and then forms a jelly, which subsequently separates into a colourless shrunken clot and serum. This shows that the corpuscles are not an essential part of the clot.

If a few cubic centimetres of the same plasma be diluted with 50 times its bulk of a .75 p.c. solution of sodium chloride¹ coagulation is

¹ A solution of sodium chloride of this strength will hereafter be spoken of as 'normal saline solution.'

much retarded, and the various stages may be more easily watched. As the fluid is becoming viscid, fine fibrils of fibrin will be seen to be developed in it, especially at the sides of the containing vessel. As these fibrils multiply in number, the fluid becomes more and more of the consistence of a jelly, and at the same time somewhat opaque. Stirred or pulled about with a needle, the fibrils shrink up into a small opaque stringy mass; and a very considerable bulk of the jelly may by agitation be resolved into a minute fragment of shrunken fibrin floating in a quantity of what is really diluted serum. If a specimen of such diluted plasma be stirred from time to time, as soon as coagulation begins, with a needle or glass rod, the fibrin may be removed piecemeal as it forms, and the jelly-stage may be altogether done away with. When fresh blood which has not yet had time to coagulate is stirred or whipped with a bundle of rods (or anything presenting a large amount of rough surface), no jelly-like coagulation takes place, but the rods become covered with a mass of shrunken fibrin. Blood thus whipped until fibrin ceases to be deposited, is found to have entirely lost its power of coagulation. Putting all these facts together, it is very clear that the coagulation of blood is due to the appearance in the plasma of fine fibrils of fibrin. As long as these are scanty, the blood is simply viscid. When they become sufficiently numerous, they give the blood the firmness of a jelly. Soon after their formation they begin to shrink; and in their shrinking enclose in their meshes the corpuscles, but squeeze out the remaining fluid parts of the blood. Hence the appearance of the shrunken coloured clot and the colourless serum.

Fibrin, whether obtained by whipping freshly-shed blood, or by washing a normal clot, or a clot obtained from colourless plasma, exhibits the same general characters. It is a proteid; and gives the ordinary proteid reactions. It is insoluble in water and in dilute saline solutions; and though it swells up in dilute hydrochloric acid, it is not thereby appreciably dissolved (see Appendix).

Minor differences have been stated to exist in the characters of fibrin obtained, in various ways and from various sources, *ex gr.* by whipping or by washing a blood-clot, from venous or from arterial blood. But these differences are unimportant. The characters are said to vary also in different animals.

Coagulation then is due to the appearance in the blood-plasma of a substance, fibrin, which previously did not exist there as such. Such a substance must have antecedents, or an antecedent—what are they, or what is it?

If blood be received direct from the blood-vessels into one-third its bulk of a saturated solution of some neutral salt, such as magnesium sulphate, and the two gently but thoroughly mixed, coagulation, especially at a moderately low temperature, will be deferred for a very long time. If the mixture be allowed to stand, the corpuscles will sink, and a colourless plasma will be obtained similar to the plasma gained from horse's blood by cold, except that

it contains an excess of the neutral salt. The presence of the neutral salt has acted in the same direction as cold: it has prevented the occurrence of coagulation. It has not destroyed the fibrin; for if some of the plasma be diluted with ten or more times its bulk of water, it will coagulate speedily in quite a normal fashion, with the production of quite normal fibrin. 6

If some of the colourless transparent plasma, obtained either by the action of neutral salts from any blood, or by the help of cold from horse's blood, be treated with some solid neutral salt, such as sodium chloride, to saturation, a white flaky somewhat sticky precipitate will make its appearance. If this precipitate be removed, the fluid is no longer coagulable (or very slightly so), even though the neutral salt present be removed by dialysis, or its influence lessened by dilution. With the removal of the substance precipitated, the plasma has lost its power of coagulating.

If the precipitate itself, after being washed with a saturated solution of the neutral salt (in which it is insoluble) so as to get rid of all serum and other constituents of the plasma, be treated with a small quantity of water, it readily dissolves, and the solution rapidly filtered gives a clear colourless filtrate, which is at first perfectly fluid. Soon, however, the fluidity gives way to viscosity, and this in turn to a jelly condition, and finally the jelly shrinks into a clot floating in a clear fluid; in other words, the filtrate clots like plasma. Thus there is present in cooled plasma, and in plasma kept from clotting by the presence of neutral salts, a something, precipitable by saturation with neutral salts, a something which, since it is soluble in water, or in very dilute saline solutions, cannot be fibrin itself, but which in solution speedily gives rise to the appearance of fibrin. To this substance its discoverer, Denis¹, gave the name of *plasmine*. We are justified in saying that the coagulation of blood is due to the conversion of *plasmine* into fibrin.

The question now arises, What is the exact nature of *plasmine*? Is it for instance a mixture of two or more substances which by their interaction produce fibrin? This view is suggested by the fact that *plasmine* cannot be kept *in solution* for any length of time without changing into fibrin, except when submitted to certain influences, such as cold. It is moreover supported by the following facts.

The disease known as hydrocele is characterized by the presence in the tunica vaginalis (or serous sac of the testis) of an abnormal and often very considerable quantity of a clear, colourless, or faintly yellow fluid very similar to the serum of clotted blood. This secretion, when drawn from the living body without admixture of blood, will in the great majority of cases remain perfectly fluid, and enter into decomposition without having shown any tendency whatever to clot. In a few exceptional cases a coagulation, generally slight, but quite similar to that of colourless blood-plasma, may be observed.

¹ *Ann. d. Sci. Nat.*, (iv.) x. p. 25.

If a small quantity of hydrocele fluid which has been observed not to clot spontaneously be mixed with some serum or whipped blood, the mixture will after a longer or shorter time clot in a completely normal manner. That is to say, two fluids neither of which apart clot spontaneously, will clot spontaneously when mixed together. In some cases no clot is formed; specimens of hydrocele fluid are occasionally met with in which coagulation cannot be thus produced.

If serum be treated to saturation with solid sodium chloride, a flaky precipitate very similar in general appearance to plasmine will make its appearance. Like plasmine this precipitate is soluble in very dilute neutral saline solutions, and in consequence as thus prepared readily dissolves when treated with distilled water, since a certain amount of sodium chloride clings to it. Unlike plasmine, its filtered solution will not clot. If, however, some of the solution be added to hydrocele fluid, a clotting takes place just the same as when serum itself is added. The rest of the serum from which this substance has been removed will not, after the removal by dialysis of the excess of salt, cause clotting in hydrocele fluid. Evidently it is the presence of this constituent, not coagulable of itself, which gives to serum its power of producing a coagulation in hydrocele fluid. The substance in question may also be prepared by diluting blood-serum with ten or twenty times its bulk of water and passing a brisk stream of carbonic acid through it. The mixture speedily becomes turbid, and if left to stand a copious white amorphous somewhat granular precipitate settles down. The substance so thrown down belongs by its characters to the class of globulins (see Appendix). It is readily soluble in dilute neutral saline solutions, and its solutions in these cause coagulation of hydrocele fluid. It may also be thrown down by very cautiously adding dilute acetic acid to dilute serum. It has received the name of *fibrinoplastin* or *fibrinoplastic globulin* or *paraglobulin*.

If, on the other hand, hydrocele fluid, specimens of which have been observed to coagulate on the addition of serum or fibrinoplastin, be treated in the same way either with carbonic acid or with sodium chloride to saturation, a precipitate is obtained similar to, but more flaky and less granular in nature than, that produced in serum. When this precipitate, to which the name of *fibrinogen* has been given, dissolved in dilute neutral saline solution, is added to serum, the mixture coagulates spontaneously, while the hydrocele fluid from which the substance has been removed no longer causes coagulation in serum. Thus fibrinoplastin from serum causes coagulation of hydrocele fluid, and fibrinogen from hydrocele fluid causes coagulation of serum, though neither alone coagulate spontaneously. And serum deprived of its fibrinoplastin, and hydrocele fluid deprived of its fibrinogen, have lost all power of coagulating each other.

It is worthy of remark that fibrinoplastin is more easy of extraction than fibrinogen, and that hydrocele fluid is much more readily and firmly coagulated by fibrinoplastin than is serum by fibrinogen.

Lastly, if solid fibrinoplastin and fibrinogen, prepared by the sodium chloride method, be together dissolved in dilute saline solution, the fluid mixture will coagulate spontaneously with the production of quite normal fibrin.

These facts seem to shew that plasmine is a mixture of fibrinogen and fibrinoplastin; indeed an artificial mixture of the two latter, obtained from serum and hydrocele fluid respectively, would be undistinguishable from the former obtained from plasma. It must however be remembered that no one has yet succeeded in separating natural plasmine into fibrinogen and fibrinoplastin¹.

There are moreover facts which shew that the above statements do not cover the whole ground; there is evidence of the existence of a third factor in the process.

1. If fibrinogen and fibrinoplastin be isolated by the carbonic acid method, their mixture in a saline solution clots with great difficulty or not at all; prepared by the saturation method, they give a good firm clot. This suggests that something retained by the latter method is lost by the former method.

2. Normal blood-plasma must naturally contain an excess of fibrinoplastin, since after coagulation the serum still contains a considerable quantity of that body. Yet even in blood-plasma, fibrinoplastin, under certain circumstances, will favour coagulation. If three parts of plasma be mixed with one part of a solution of magnesium sulphate (one of the salt to three and a half of water), the mixture diluted with eight parts of water will afford a dilute plasma, in which spontaneous coagulation will either not occur at all or come on very slowly indeed. In this dilute plasma the fibrinoplastin is still in excess. Nevertheless the addition of a further quantity of fibrinoplastin, prepared by saturation with sodium chloride, will speedily cause coagulation. From this it may be inferred that in adding the fibrinoplastin thus prepared something else is added as well.

3. If blood-serum or defibrinated blood be poured into about twenty times its bulk of strong spirit and the mixture allowed to stand for some three weeks, or longer, the proteid matters including the fibrinoplastin become coagulated and almost wholly insoluble in water. Hence if the spirit be filtered off from the copious precipitate, and the latter dried at a low temperature (below 40°) and extracted with distilled water, the aqueous extract contains no palpable amount of proteid material and gives but slight reactions with proteid tests. A small quantity of this aqueous extract of blood, however, though free from fibrinoplastin, will when added to the dilute plasma, spoken of above, bring about a rapid coagulation.

4. If the pericardial cavity of a large mammal (ox, horse, sheep) be laid open *immediately after death*, the fluid removed will coagulate spontaneously and rapidly. The clot will on examination be found to consist of a

¹ We owe the discovery of fibrinoplastin and fibrinogen to A. Schmidt, whose earlier papers will be found in Reichert and Du Bois-Reymond's *Archiv*, 1861, p. 545, and 1862, p. 428. Schmidt's later results, which are discussed in the succeeding portions of this section, are contained in papers published in Pilgner's *Archiv*, vi. (1872) p. 413; xi. (1875). pp. 291 and 515; xiii. pp. 93 and 146.

meshwork of normal fibrin in which are entangled a multitude of white corpuscles. If the opening of the body be deferred to some twenty or more hours after death, the pericardial fluid will be found either not to coagulate at all or to coagulate very slowly and feebly.

When, however, fibrinoplastin prepared by the saturation method is added to such a pericardial fluid a rapid and complete coagulation is generally brought about. But precisely the same coagulation may in many cases be brought about by the simple addition of the aqueous extract just described. Most pericardial fluids in fact behave extremely like the dilute plasma spoken of above.

Here then are indications of the existence of a substance which is neither fibrinogen nor fibrinoplastin, but which nevertheless appears to be as necessary as either of the other two for the occurrence of coagulation. This third substance will not bring about coagulation with fibrinogen alone or with fibrinoplastin alone. It will not bring about coagulation in fluids such as ordinary hydrocele fluid, in which fibrinoplastin is apparently absent, nor in serum, in which fibrinogen is absent. It is efficacious only in such cases where there are reasons for thinking that both fibrinoplastin and fibrinogen are present. But its most important feature is the following. In the cases in which coagulation is brought about by the addition of fibrinoplastin to fibrinogenous liquids, the quantity of fibrin produced bears, within certain limits, a proportion to the quantity of fibrinoplastin added; whereas the addition of aqueous extract of blood only affects the *rapidity* with which coagulation sets in, and not at all the quantity of fibrin produced. In other words, the aqueous extract does not contribute to the substance of the fibrin, but favours, or is essential to, the union of, the two fibrin factors. That is to say, the substance in the aqueous extract which thus affects coagulation belongs to that class of substances which promote the union of other bodies, or cause changes in other bodies, without themselves entering into union or undergoing change. These substances we shall hereafter learn to speak of as "ferments;" and this particular substance has been called by its discoverer, A. Schmidt¹, fibrin-ferment. Obviously the ferment is present in blood-plasma, in plasmine, and in fibrinoplastin as prepared by the saturation method, but is apparently in large measure lost when fibrinoplastin is prepared by the carbonic acid method.

In conclusion then we may say, that coagulation is the result of the interaction of two bodies, fibrinoplastin and fibrinogen, brought about by the agency of a third body, fibrin-ferment. Where these three bodies are all present, as in blood-plasma, in plasmine, in pericardial fluid taken from the body immediately after death, spontaneous coagulation is witnessed: where the ferment is absent, but the other factors are present, as in many cases of pericardial fluid removed some time after death, coagulation will take place on the addition of ferment alone: where both ferment and fibrinoplastin are absent, as in many cases of hydrocele fluid, both these must be added before coagulation can come on.

The exact nature of the process by which the presence of all three factors leads to the formation of fibrin cannot be at present defined more closely than by the phrase 'interaction.' Beyond the broad fact that the quantity of fibrin formed is dependent on the quantity of fibrinoplastin

¹ *Op. cit.*

and fibrinogen present, we have no knowledge of quantitative relations between the two constituents. That they do not unite simply together, as a base with an acid, seems to be clearly shewn by the fact, stated by Schmidt, that in artificial coagulations the quantity of fibrin formed is by weight always less than that of the fibrinoplastin used. Hammarsten¹ argues that the fibrinoplastin, or, as he would prefer still to call it, paraglobulin does not enter in any way into the fibrin, the latter being simply transformed fibrinogen. He explains the fibrinoplastic properties of paraglobulin as due to that substance obviating certain hindrances to the formation of the fibrin, for instance, preventing the solution by saline or other bodies of the fibrin while it is in what may be called a nascent condition, *i. e.* in a stage intermediate between fibrinogen and fibrin. According to him the quantity of fibrinoplastin present in a coagulating fluid, though of marked effect on the quantity of fibrin produced, has no effect on the total quantity of fibrinogen used up, *i. e.* transformed into fibrin or into something else.

Still the conception of coagulation as a chemical process between certain factors renders easy of comprehension the influence of various conditions on the coagulation of blood. The quickening influence of heat, the retarding effect of cold, the favourable action of motion and of contact with surfaces, and hence the results of whipping and the influence exerted by the form and surface of vessels, become intelligible. The greater the number of points, that is the larger and rougher the surface presented by the vessel into which blood is shed, the more quickly coagulation comes on, for contact with surfaces favours chemical union. So also the presence of spongy platinum, or of an inert powder like charcoal, quickens the coagulation of tardily clotting fluids, such as many cases of pericardial fluid.

The action of neutral salts is still obscure. Schmidt has shewn that the presence of a neutral salt, such as sodium chloride, is essential to the process, coagulation not occurring even where all three factors are present, if no neutral salt accompany them; thus bringing fibrin coagulation after all into the same category as the coagulation of albumin by heat: see Appendix. The presence of hæmoglobin also, independently of the fibrinoplastin which may be present in the red corpuscles, appears to favour coagulation.

Having thus arrived at an approximative knowledge of the nature of coagulation, we are in a better position for discussing the question, Why does blood remain fluid in the vessels of the living body and yet clot when shed?

The older views may be at once summarily dismissed. The clotting is not due to loss of temperature, for cold retards coagulation, and the blood of cold-blooded animals behaves just like that of warm-blooded animals in clotting when shed. It is not due to loss of motion, for motion favours coagulation. It is not due to exposure to air, whereby either an increased access of oxygen or an escape of volatile matters is facilitated, for on the one hand the blood is fully exposed to the air in the lungs, and on the other shed blood

¹ Pfüger's *Archiv*, xiv. (1877), 211.

clots when received, without any exposure to the atmosphere, in a closed tube over mercury.

All the facts known to us point to the conclusion, that when blood is contained in healthy living blood-vessels, a certain relation or equilibrium exists between the blood and the containing vessels of such a nature that as long as this equilibrium is maintained the blood remains fluid, but that when this equilibrium is disturbed by events in the blood or in the blood-vessels or by removal of the blood, the blood undergoes changes which result in coagulation. The most salient facts in support of this conclusion are as follows.

1. After death, when all motion of the blood has ceased, the blood remains for a long time fluid. It is not till some time afterwards, at an epoch when post-mortem changes in the blood and in the blood-vessels have had time to develop themselves, that coagulation begins. Thus some hours after death the blood in the great veins may be found perfectly fluid. Yet such blood has not lost its power of coagulating; it still clots when removed from the body, and clots too when received over mercury without exposure to air, shewing that the fluidity of the highly venous blood is not due to any excess of carbonic acid or absence of oxygen. Eventually it does clot even within the vessels, but never so firmly and completely as when shed. It clots first in the larger vessels, remaining for a very long time, for many hours in fact, fluid in the smaller veins, where the same bulk of blood is exposed to the influence of, and reciprocally exerts an influence on, a larger surface of the vascular walls than in the larger veins. Thus if the foot of a sheep be ligatured and amputated, the blood in the small veins will be found fluid and yet coagulable for many hours.

2. If the vessels of the heart of a turtle (or any other cold-blooded animal) be ligatured, and the heart be cut out and suspended so that it may continue to beat for as long a period as possible, the blood will remain fluid within the heart as long as the pulsations go on, *i.e.* for one or two days (and indeed for some time afterwards), though a portion taken away at any period of the experiment will clot very speedily¹.

3. If the jugular vein of a large animal, such as an ox or horse, be ligatured when full of blood, and the ligatured portion excised, the blood in many cases remains perfectly fluid, along the greater part of the length of the piece, for twenty-four or even forty-eight hours. The piece so ligatured may be suspended in a framework and opened at the top so as to imitate a living test-tube, and yet the blood will often remain long fluid, though a portion removed at any time into another vessel will clot in a few minutes. If two such living test-tubes be prepared, the blood may be poured from one to the other without coagulation taking place².

¹ Brücke, *Brit. and For. Med. Chir. Review*, xix. p. 183 (1857).

² Lister, *Proc. Roy. Soc.*, xii. p. 580 (1858).

The above facts illustrate the absence of coagulation in intact or slightly altered living blood-vessels; the following shew that coagulation may take place even in the living vessels.

4. If a needle or piece of wire or thread be introduced into the living blood-vessel of an animal, either during life or immediately after death, the piece will be found encrusted with fibrin. \U

\U 5. If in a living animal a blood-vessel be ligatured, the ligature being of such a kind as to injure the inner coat, coagulation takes place at the ligature and extends for some distance from it. Thus if the jugular vein of a rabbit be ligatured roughly in two places, clots will in a few hours be found in the ligatured portion, reaching upwards and downwards from each ligature, the middle portion being the least coagulated. Clots will also be found on the far side of each ligature. The clots will still appear if the ligature be removed immediately after being applied, provided that in the process the inner coat has been wounded. If the ligatures be applied in such a way as not to injure the inner coat, coagulation will not take place, though the blood may remain for many hours perfectly at rest between the ligatures.

6. When an artery is ligatured a conspicuous clot is formed on the cardiac side of the ligature. The clot is largest and firmest in the immediate neighbourhood of the ligature, gradually thinning away from thence and reaching usually as far as where a branch is given off. Between this branch and the ligature there is stasis; the walls of the artery suffer from the want of renewal of blood, and thus favour the propagation of the coagulation. On the distal side of the ligature where the artery is much shrunken, the clot which is formed, though naturally small and inconspicuous, is similar.

7. Any injury of the inner coat of a blood-vessel causes a coagulation at the spot of injury. Any treatment of a blood-vessel tending to injure its normal condition causes local coagulation. .

8. Disease involving the inner coat of a blood-vessel causes a coagulation at the part diseased. Thus inflammation of the lining membrane of the valves of the heart in endocarditis is frequently accompanied by the deposit of fibrin. In aneurism the inner coat is diseased, and layers of fibrin are commonly deposited. So also in fatty and calcareous degeneration without any aneurismal dilatation there is a tendency to the formation of clots.

9. Similar phenomena are seen in the case of serous fluids which coagulate spontaneously. If, as soon after death as the body is cold and the fat is solidified, the pericardium be carefully removed from a sheep by an incision round the base of the heart, the pericardial fluid may be kept in the pericardial bag as in a living cup for many hours without clotting, and yet a small portion removed with a

pipette clots at once, and a thread left hanging into the fluid soon becomes covered with fibrin.

The only interpretation which embraces these facts is that so long as a certain normal relation between the lining surfaces of the blood-vessels and the blood is maintained, coagulation does not take place; but when this relation is disturbed by the more or less gradual death of blood-vessels, or by their more sudden disease or injury, or by the presence of a foreign body, coagulation sets in. Two additional points may here be noticed. 1. Stagnation of blood favours coagulation within the blood-vessels, apparently because the blood-vessels, like other tissues, demand a renewal of the blood on which they depend for the maintenance of their vital powers. 2. The influence of surface is seen even in the coagulation within the vessels. In cases of coagulation from gradual death of the blood-vessels, as in the case of an excised jugular vein, the fibrin, when its deposition is sufficiently slow, is seen to appear first at the sides, and from thence gradually, frequently in layers, to make its way to the centre. So in aneurism, the deposit of fibrin is frequently laminated. In cases where coagulation results from disease of the lining membrane, the rougher the interior, the more speedy and complete the clotting. So also a rough foreign body, presenting a large number of surfaces and points of attachment, more readily produces a clot when introduced into the living blood-vessels than a perfectly smooth one.

Clear as it seems to be that some vital relation of blood to blood-vessel is the dominant condition affecting coagulation, it is by no means easy to state distinctly what is the exact nature of that relation. Some authors¹ speak of the blood-vessels as exercising a restraining influence on the natural tendency of the blood to coagulate. Others² regard the living blood-vessel (and indeed living matter in general) as being wholly inert towards the fibrin-factors. These they consider need the presence, the contact influence of some body, in order that they may act on each other to form fibrin; thus contact with the sides of the vessel into which blood is shed, or with the surface of a foreign body introduced into a living vessel, is, according to them, the determining cause of coagulation. They suppose that living matter exercises no such contact influence.

Before this point can be decided, further knowledge is needed concerning the exact condition of the fibrin-factors in living blood within the body. While the blood is flowing uncoagulated through the vessels are all the three fibrin-factors, fibrinoplastin, fibrinogen and ferment, already present in plasma? Or are they all, or is one or two absent, and if so is the appearance of them, or of one of them, in the plasma, the necessary invisible forerunner of coagulation? Our scanty information on this point may be summarized as follows.

1. In all spontaneously coagulable fluids white corpuscles are present, and the more abundant they are, the more pronounced is the coagulation.

¹ Brücke, *op. cit.*

² Lister, *op. cit.*

Thus the spontaneously coagulating pericardial fluid is exceedingly rich in white corpuscles, and the clot formed seems under the microscope to be almost entirely composed of them, so completely do they hide the threads of fibrin. In the specimens of pericardial and of hydrocele fluid which do not coagulate spontaneously white corpuscles are absent, or at least scanty.

2. The deposition of fibrin round a thread if dipped into a coagulable fluid or drawn through a blood-vessel and left there, is preceded by an accumulation of white corpuscles. These cluster in greater numbers round the thread, and when the mass is examined under the microscope the corpuscles seem to serve as starting points for the development of the threads of fibrin.

3. In the experiment of keeping blood fluid but coagulable in an excised jugular vein (of the horse), it is observed that when, as in course of time happens, the corpuscles have sunk to the bottom of the piece of vein, the upper layers of clear, corpuscle-free, plasma clot very feebly indeed when removed from the vein, whereas the lower layers rich in corpuscles clot most firmly.

4. When horse's blood is received from a blood-vessel into an ice-cold dilute solution of chloride of sodium, and the mixture kept just short of actually freezing, the whole mass of corpuscles sinks rapidly. It is then observed that the dilute plasma free from corpuscles clots feebly, whereas the lower layers of the same dilute plasma, containing all the corpuscles, gives an abundant coagulation. Plasma of horse's blood may be diluted with twelve times its bulk of distilled water and filtered, without coagulation setting in, provided that the whole operation is conducted at a temperature just short of freezing. The filtered diluted plasma, which is found to be exceedingly free from white corpuscles, these being left on the filter, clots feebly; the amount of fibrin it produces is less than half that obtainable from the same diluted plasma unfiltered¹.

These facts point very decidedly to the conclusion that the white corpuscles have some share in bringing about coagulation; they moreover suggest that one or more of the fibrin-factors have their source in the white corpuscles, and that coagulation is due to the passage of these elements from the body of the corpuscle into the plasma. The latter view is corroborated by the following facts.

5. In defibrinated blood or blood-serum a certain amount of fibrin-ferment is present. If however blood be treated with alcohol immediately on leaving the blood-vessels, very little ferment indeed is found to be present. The quantity is found to increase from the moment of leaving the vessels to the onset of coagulation. The fibrin-ferment therefore is developed from some part of the blood. If horse's blood be kept at freezing temperature, the formation of ferment is arrested. If after the corpuscles have sunk the undermost layers of the blood, containing almost exclusively red corpuscles, be removed, little or no ferment can be obtained from this portion, either when examined immediately, or after being allowed to clot at an ordinary temperature. In a portion taken from the upper layers (colourless plasma) of the same blood, while there is little or no ferment present before the coagulation of the specimen, there is abundance afterwards. If a

¹ A. Schmidt, *op. cit.*

similar portion of the same colourless plasma be filtered in the cold, the filtrate, which is nearly free from white corpuscles, is very poor in ferment both before and after the feeble and slow coagulation which the fluid undergoes; the material on the filter, consisting almost entirely of white corpuscles, is very rich in ferment. These facts seem to show that the fibrin-ferment which is present in blood-serum has its source, not in the red but in the white corpuscles, and that the passage of the ferment from the white corpuscle into the plasma is a precursor of coagulation.

6. The coagulation of filtered diluted plasma has been said to be both feeble and slow. The tardiness of the coagulation is due to the paucity of ferment; the feebleness, *i.e.* the small quantity of fibrin produced, must be due to the scantiness of one or both of the fibrin-factors. On adding fibrinoplastin the quantity of fibrin produced is the same as that given by the same quantity of unfiltered plasma. The filtered plasma is therefore deficient in fibrinoplastin. The material left on the filter is rich in fibrinoplastin. The inference which A. Schmidt draws from these facts, is that fibrinoplastin, like the fibrin-ferment, has its origin in the white corpuscles, but that fibrinogen is a normal constituent of the plasma.

7. If a drop of horse's plasma kept from coagulating by cold be examined under the microscope, it will be found to contain a large number of white corpuscles mixed with which are corpuscles of an intermediate character between white and red, *i.e.* nucleated cells whose protoplasm is loaded with coloured hæmoglobin granules. As the drop is watched, a large number of the white corpuscles and all the intermediate forms are seen to break up into a granular detritus. This breaking up of the white corpuscles is the precursor of coagulation, the threads of fibrin seeming to start from the remains of the corpuscles. Putting all these facts together, Schmidt concludes that when blood is shed, a number of white and intermediate corpuscles fall to pieces, by which act a quantity of fibrin-ferment and of fibrinoplastin is discharged into the plasma. These meeting there with the already present fibrinogen give rise to fibrin, and coagulation results. In other mammals coagulation even at low temperatures is too rapid to permit of the changes in the corpuscles being watched as satisfactorily as in the horse, but even in these evidences of the existence of intermediate forms may be met with.

This view excludes the red corpuscles, as far as mammals are concerned, from any direct share in coagulation. Whether this ultimately prove to be correct or not, there are facts which shew that the nucleated red corpuscles of other vertebrates, which it must be remembered are the homologues of the intermediate forms, have a much clearer connection with the process. If the defibrinated blood of the frog or the bird be allowed to stand until the corpuscles have subsided, the latter, separated as much as possible from the serum, and treated with a considerable quantity of distilled water, yield a filtrate which coagulates spontaneously. That is to say, the water breaks up the red corpuscles and sets free a quantity of fibrin-factors which otherwise would have remained latent. The amount of fibrin thus obtained may be considerably greater than the quantity originally appearing in the blood. It is worthy of notice, that in this case the corpuscle is the source, not only of the fibrin-ferment and fibrinoplastin, but also of the fibrinogen.

Accepting this view as approximately correct, the coagulation of shed blood may be referred to the circumstance, that even the comparatively slight changes which must take place in the blood on its leaving the vessels are sufficient to entail the death, and so the breaking up, of a number of the delicate white corpuscles. The formation of clots within the body is not so easy to explain. We are driven in these cases to suppose that injured and diseased spots or foreign bodies first attract, and then, as it were by irritation, cause the death of a certain number of corpuscles.

But in any case, if this view be admitted, it must also be granted that the blood-vessels do in some manner or other exercise a restraining influence on the formation of fibrin. For many of these corpuscles must, in the natural course of events, die and break up in the blood-stream, without causing coagulation. Further, defibrinated blood contains both fibrin-ferment and fibrinoplastin; it ought, therefore, when injected into the vessels which already in the natural blood contain fibrinogen, to occasion a rapid and speedy general coagulation. This it does not. The coagulations which occur after transfusion of defibrinated blood are partial and uncertain. We might infer from this that the system has some power of rapidly either destroying ferment or changing the properties of fibrinoplastin. In support of this it has been stated, that a quantity of fibrin-ferment injected into the system may be detected in the blood immediately afterwards (and is present then without causing coagulation), but speedily disappears. The loss of spontaneous coagulability in pericardial fluid might be attributed to an escape by migration of the white corpuscles away from the pericardial cavity, but this is inconsistent with the fact that in the majority of cases the ferment alone disappears while the fibrinoplastin remains. According to the facts given above, the white corpuscles in escaping would carry away both ferment and fibrinoplastin, leaving the fibrinogen alone. Lastly, we should remember that all the above, even if correct, is only an approximative solution. The coagulation of muscle-plasma is a coagulation in which white corpuscles cannot serve as *Dei ex machina*; moreover, as we shall see later on, the rigor mortis of the white corpuscle itself is a coagulation; and for this its own subsequent disintegration cannot be regarded as an adequate cause.

SEC. 3. THE HISTORY OF THE CORPUSCLES.

In the living body red blood-corpuscles are continually being destroyed, and new ones as continually being produced. The proofs of this are,

1. The number of the red corpuscles in the blood at any given time (as determined by the examination of a drop of blood) varies much. After a very large reduction of the total number of red corpuscles, as by hæmorrhage or disease (anæmia), the normal proportion may be regained even within a very short time.

2. There are reasons for thinking that the urinary and bile-pigments are derivatives of hæmoglobin. If this be so, an immense number of corpuscles must be destroyed daily (and replaced by new ones) in order to give rise to the amount of urinary and bile-pigment discharged daily from the body.

3. When the blood of one animal is injected into the vessels of

another (*ex. gr.* that of a bird into a mammal), the corpuscles of the first may for some time be recognised in blood taken from the second; but eventually they wholly disappear. This of course is no strong evidence, since the destruction of foreign corpuscles might take place even though the proper ones had a permanent existence.

Origin of the Red Corpuscles.

In the embryo red corpuscles are produced,

1. From metamorphosis of certain mesoblastic cells in the vascular area.

2. By division of the corpuscles thus formed.

3. In a somewhat later stage, by the transformation of nucleated white corpuscles, which probably arise in the liver and spleen, and pass thence into the blood. The cell-substance becomes impregnated with hæmoglobin, and the nucleus breaks up and disappears.

4. By the direct transformation of the protoplasm of undifferentiated connective-tissue corpuscles¹, the red corpuscle appearing first as a minute speck in the protoplasmic cell-substance, and subsequently enlarging very much after the fashion of an oil-globule.

In the adult, division of existing corpuscles is at least exceedingly rare, if it occurs at all. In the spleen-pulp small nucleated coloured corpuscles have been observed similar to those met with in the embryo; transitional forms, shewing the presence of hæmoglobin in the cell-substance and degeneration of the nucleus, have been seen. In the wide capillaries of the red medulla of bones similar transitional forms have been observed, and they have also been noticed in circulating blood.

According to Alex. Schmidt², in living unchanged blood these forms are abundant; they break up and disappear, however, immediately that the blood is shed, unless special precautions (application of cold &c.) be used.

From these several facts it is concluded that the red corpuscles take origin from colourless nucleated corpuscles similar to, if not identical with, the ordinary white corpuscles of the blood.

In the case of animals with nucleated red corpuscles the change consists chiefly in a transformation of the native protoplasm of the white corpuscle into hæmoglobin and stroma. In the case of animals with non-nucleated red corpuscles, most observers³ agree in the opinion that the nucleus of the white corpuscle breaks up and disappears, so that the red corpuscle represents only the modified cell-substance of its progenitor. Wharton Jones, supported by Huxley, resting chiefly on the parallelism in size and form between the nuclei of the white corpuscles and the entire red corpuscles in different orders and families of mammals, concludes that the latter is in reality the naked coloured nucleus of the former.

Origin of the White Corpuscles.

That the white corpuscles are continually being removed is evi-

¹ Schäfer, *Proc. Roy. Soc.*, xxii. 243. ² *Op. cit.* ³ Kölliker, Neumann, Schmidt.

dent from the fact that they vary extremely in number at different times and under various circumstances. They are very largely increased by taking food. Thus during fasting they may be seen in a drop of blood to bear to the red the proportion of 1 in 800 or 1000. After a meal this proportion rises to 1 in 300 or 400.

The fact that in the lymphatic glands, follicles and other adenoid structures, corpuscles, similar to if not identical with white blood-corpuscles, are to be seen of very various sizes and with dividing nuclei, suggests that these organs are the birth-places of the white corpuscles. The lymph is continually pouring into the blood a crowd of white corpuscles, which for the most part make their appearance in the lymph-vessels after the latter have traversed the lymphatic glands. And this view is further supported by the fact that in the disease Leuchæmia, where the white corpuscles are so abundant as to number as much as 1 to 10 red, the spleen, the lymphatic glands, and other forms of adenoid tissue, are enlarged. (The phenomena are however capable of a converse interpretation, viz. that the white corpuscles, failing to become converted into red corpuscles, are crowded into the lymphatic organs.)

At the same time it is open for us to suppose that any proliferating tissue may give rise to new corpuscles; and Klein¹ states that he has seen them budded off from the reticulum of the spleen. The white corpuscles have also been observed to divide².

We may conclude therefore that the white corpuscles probably arise, chiefly by division, from the leucocytes of adenoid tissue, but that other sources may exist.

Fate of the White Corpuscles.

As we have seen, it is extremely probable that a large number of the white corpuscles end by giving birth to red corpuscles. We know that in an inflamed area the white corpuscles migrate in large numbers into the extravascular elements of the tissues, and there are reasons for thinking that the new structures which make their appearance as the result of inflammation may arise in part at least from such migratory corpuscles. But the question to what extent this takes place, and how far the white corpuscles are concerned in tissue regeneration, is too unsettled and too long a matter to be discussed here.

Fate of the Red Corpuscles.

In the spleen we find, as Kölliker pointed out a long time ago, large protoplasmic cells in which are included a number of red corpuscles: and these red corpuscles may be observed in various stages of apparent disintegration. It is probable therefore that the spleen is the grave of many of the red corpuscles. Since serum of fresh blood contains no dissolved hæmoglobin, it is clear that the hæmoglobin of the broken-up corpuscles must speedily be transformed into some other body. Into what other body? In old blood-clots

¹ *Q. J. Micros. Sci.* xv. (1875) p. 370.

² Klein, *Hdb. Phys. Lab.* p. 8.

(as in those of cerebral hæmorrhage) there are frequently found minute crystals of a body which has received the name *Hæmatoidin*. There can be no doubt that the hæmatoidin of these clots is a derivative from the hæmoglobin of the escaped blood. We know¹ that hæmoglobin contains a residue of hæmatin. We know further that hæmatin may lose its iron (which appears to be loosely attached), and yet remain a coloured body. So that there is no difficulty in the passage from the proteid-and-iron containing hæmoglobin to the proteid-and-iron free hæmatoidin. But hæmatoidin, not only in the form and appearance of its crystals, but also, as far as can be ascertained, by the analysis of the small quantities at disposal, in its chemical composition is identical with *bilirubin*, the primary pigment of bile. Moreover, the injection of hæmoglobin, or of dissolved red corpuscles, into the vessels of a living animal, gives rise to a large amount of bile-pigment in the urine, and at the same time increases enormously the relative quantity of *bilirubin* in the bile. Thus though no one has yet succeeded in producing *bilirubin* artificially from hæmoglobin, facts point very strongly to the view that the red corpuscles are used up to supply bile-pigment.

It must be added however that, according to Preyer², the spectra of hæmatoidin and bilirubin are quite distinct, and that many observers have failed to obtain bile-pigment in the urine as the result of injection of a solution of hæmoglobin. Blood-clots frequently contain, besides or in place of hæmatoidin, a yellow substance named *lutein*, which is certainly distinct from bilirubin. *Lutein* is the substance which gives to corporea lutea their characteristic colour. Our knowledge of urinary pigments is so imperfect that little can be said as to their relation to hæmoglobin. We cannot at present definitely trace the normal urinary pigment back to hæmoglobin, however probable such a source may seem; but Jaffé finds in many urines, especially those of fever-patients, a body called *urobilin*, identical with *hydrobilirubin* obtained from bilirubin by reduction with sodium amalgam³.

SEC. 4. THE QUANTITY OF BLOOD, AND ITS DISTRIBUTION IN THE BODY.

The total quantity of blood present in an animal body is estimated in the following way. As much blood as possible is allowed to escape from the vessels; this is measured directly. The vessels are then washed out with water or normal saline solution, and the washings carefully collected, mixed and measured. A known quantity of blood is diluted with water or normal saline solution until it possesses the same tint as a measured specimen of the washings. This gives the amount of blood (or rather of hæmoglobin) in the measured specimen, from which the total quantity in the whole washings is calculated. Lastly, the whole body is carefully minced and washed free from blood. The washings are collected and filtered,

¹ See Chapter on Changes of Blood in Respiration.

² *Die Blut-Krystalle.*

³ Cf. Liebermann, Pflüger's *Archiv.* xi. p. 181.

and the amount of blood in them estimated as before by comparison with a specimen of diluted blood. The quantity of blood in the two washings, together with the escaped blood, gives the total quantity of blood in the body. Estimated in this way, the total quantity of blood in the human body may be said to be about $\frac{1}{13}$ th of the body-weight.

There are several sources of error in the above method. One is that venous blood has less colouring power than arterial blood. This has been met by Gscheidlen by poisoning the animal with carbonic oxide, by which all the hæmoglobin is reduced to one state, and therefore has throughout the same colouring power. The quantity of hæmoglobin in the muscular fibre itself is a source of error, but probably a very slight one. The difficulty of getting a clear infusion of the minced tissues is more serious. According to Ranke¹ the total blood in the body of a rabbit amounts to $\frac{1}{13}$ of the body-weight, in a dog to $\frac{1}{15}$, in a cat to $\frac{1}{11}$, in a frog to $\frac{1}{15}$.

The blood² is distributed as follows in round numbers:—

About one-fourth in the heart, lungs, large arteries and veins,
 " " " " liver,
 " " " " skeletal muscles,
 " " " " other organs.

Since in the heart and great blood-vessels the blood is simply in transit, without undergoing any great changes (and in the lungs, as far as we know, the changes are limited to respiratory changes), it follows that the changes which take place in passing through the liver and skeletal muscles far exceed those which take place in the rest of the body.

Ranke found the distribution to be as follows.

	In the Viscera.		In the Carcase.	
	Per cent. of Total Blood.	Per cent. of Organ Weight.	Per cent. of Total Blood.	Per cent. of Organ Weight.
Rabbit. { Living.	63·4	18·0	36·6	2·7
{ Dead and Rigid.	61·23	20·6	38·77	2·7
Dog.	59·0	24·0	41·0	3·4

In the various organs of the rabbit,

Per cent. of Total Blood.	Per cent. of Organ Weight.
Spleen 23	Skin 1·07
Brain and Cord . . 1·24	Bones 2·36
Kidneys 1·63	Al. Canal 3·46
Skin 2·10	Muscles 5·14
Intestines 6·30	Brain and Cord . . 5·52
Bones &c. 8·24	Kidney 11·86
Heart, Lungs, Great Blood-vessels . . 22·76	Spleen 12·50
Skeletal Muscles . 29·20	Liver 28·71
Liver 29·30	(Heart, Lungs, and Great Vessels . 63·11).

¹ *Blut-vertheilung*, 1871.

² Ranke, *op. cit.*

CHAPTER II.

THE CONTRACTILE TISSUES.

THE tissues of the body eminently endowed with contractility, the tissues whose primary reason of existence lies in their contractility, are the ordinary striated muscles, the cardiac muscles, the plain unstriated muscles, the ciliated cells, spermatozoa and the migrating cells. Of these the striated muscles, on account of the more complete development of their functions, are better studied first; the others, on account of their very simplicity, are in many respects less satisfactorily understood.

All the ordinary striated muscles are connected with nerves. We have no reason for thinking that their contractility is called into play, under normal conditions, otherwise than by the agency of nerves. Indeed a nerve-fibre may in part be regarded as a continuation of the muscular fibre with which it is connected by an end-plate. In *Hydra* the muscular fibre is but an eminently contractile process of an ectoderm cell, in *Beroë* the muscle-fibre thins out into a nerve-fibre which serves as a means of communication between the isolated contractile process, now an independent muscle-fibre, and the body of the ectoderm cell. Both nerve, and, as will be hereafter shown, muscle are irritable; but the muscle only is contractile. A stimulus applied to a nerve sets up disturbances which are propagated on to the muscle; but it is only the muscle in which the disturbances manifest themselves by a contraction. Neither striated muscle nor nerve-fibres distributed to muscles possess any distinct automatism. Spontaneous disturbances in either are at least rare if they occur at all. The two being thus so closely allied and in many points so similar, it will conduce to clearness and brevity if we treat them together.

SEC. 1. THE CHEMICAL SUBSTANCES COMPOSING OR PRESENT IN MUSCLE.

In a muscle from the vessels of which the blood has been carefully washed, by the injection of dilute saline solution, there will still be left a quantity of lymph surrounding the elementary fibres. The quantity however is under ordinary circumstances so small that it may be practically neglected.

If a dead muscle, from which all fat, tendon, fascia, and connective tissue have been as much as possible removed, and which has been freed from blood by the injection of saline solution, be minced and repeatedly washed with water, the washings will contain certain forms of albumin and certain extractive bodies, of which we shall speak directly. When the washing has been continued until the wash-water gives no proteid reaction, a large portion of muscle will still remain undissolved. If this be treated with a 10 p. c. solution of sodium chloride, a large portion of it will become imperfectly dissolved into a viscid fluid which filters with difficulty. If the viscid filtrate be allowed to fall drop by drop into a large quantity of distilled water, a white flocculent matter will be precipitated. This flocculent precipitate is *myosin*. It is a proteid, giving the ordinary proteid reactions, and having the same general elementary composition as other proteids. It is soluble in dilute saline solutions, especially those of sodium chloride, and may be classed in the globulin family, though it is not so soluble as fibrinoplastic globulin. Dissolved in saline solutions it readily coagulates when heated, is precipitated and after long action coagulated by alcohol, and is precipitated by an excess of the sodium chloride. By the action of dilute acids it is very readily converted into syntonin or acid-albumin, by the action of dilute alkalis into alkali-albumin. Speaking generally it may be said to be intermediate between fibrin and globulin. On keeping, and especially on drying, its solubility is much diminished.

Of the substances which are left in muscle from which the myosin has thus been extracted by sodium chloride solution little is known. If washed muscle be treated directly with dilute hydrochloric acid, the greater part of the material of the muscle passes at once into syntonin. The quantity of syntonin thus obtained may be taken as representing the quantity of myosin previously existing in the muscle. The portion insoluble in dilute hydrochloric acid consists partly of the substance of the sarcolemma, of the nuclei, and of the tissue between the bundles and partly of elements (?sarcous elements, muscle-rods) of the fibres themselves.

If living contractile frog's muscle, freed as before as much as possible from blood, be frozen¹, and while frozen, minced, and rubbed up in a mortar with four times its weight of snow containing 1 p. c. of sodium chloride, a mixture is obtained which at a temperature below 0 C. is sufficiently fluid to be filtered, though with difficulty. The slightly opalescent filtrate, or *muscle-plasma* as it is called, is at first quite fluid, but will, when exposed to the ordinary temperature become a solid jelly, and afterwards separate into a *clot* and *serum*. It will in fact coagulate like blood-plasma, with this difference, that the clot is not firm and fibrillar, but loose, granular and flocculent.

¹ Since, as we shall presently see, a muscle may be frozen and thawed again without losing any of its vital powers, we are at liberty to regard the frozen muscle as a still living muscle.

During the coagulation the fluid, which before was neutral or slightly alkaline, becomes distinctly acid.

The clot is myosin. It gives all the reactions of myosin obtained from dead muscle.

The serum contains albumin and extractives.

Besides ordinary serum-albumin coagulating at 75°, Kühne¹ (to whom we owe our knowledge of the above) found a peculiar form coagulating at 45°, its appearance being probably connected with the salts present in the serum, (see Appendix); alkali-albumin is also present, as is probably also a small quantity of globulin. Such muscles as are red also contain a small quantity of hæmoglobin, to which indeed their redness is due.

Thus while dead muscle contains myosin, serum-albumin, and extractives with certain insoluble matters and certain gelatinous elements not referable to the muscle-substance itself, living muscle contains no myosin, but some substance or substances which bear somewhat the same relation to myosin that fibrinogen and fibrinoplastin do to fibrin, and which become myosin on the death of the muscle.

Fats are present in considerable quantities, and the extractives are varied and numerous. The most important are kreatin, sarcolactic or paralactic acid (a variety of lactic acid, differing from it chiefly in the solubility of its salts, and in the amount of water of crystallization contained in them), and sugar. To these may be added xanthin, hypoxanthin, (sarkin) inosit, (especially in the cardiac muscles), inosinic acid and traces of uric acid. Except in pathological conditions (and in the plagiostome fishes) urea is conspicuous by its absence. In living muscle glycogen is frequently present, and is at the death of the muscle transformed into sugar. Dextrin has also been found; and a special fermentable muscle-sugar has been described. It has been much debated whether kreatin or kreatinin, or both, are present in muscle; the evidence goes to shew that kreatin alone is present.

The ashes of muscle, like those of the red corpuscles, are characterized by the preponderance of potassium salts and of phosphates; these form in fact nearly 80 p.c. of the whole ash.

The general composition of human muscle is shewn in the following table of v. Bibra.

Water	744.5
Solids						
Myosin and other matters, elastic elements, &c., insoluble in water	155.4
Soluble albumin	19.3
Gelatin	20.7
Extractives	37.1
Fats	23.0

255.5

¹ *Protoplasma*, Leipzig, 1864.

SEC. 2. THE PHENOMENA OF MUSCLE AND NERVE.

If the trunk of a nerve be pinched, or subjected to sudden heat, or dipped in certain chemical substances, or acted upon by various galvanic currents, movements or contractions are seen in the muscles to which branches of the nerve are distributed. The substances or agents which thus cause contractions are called 'stimuli.'

The stimuli may be applied directly to the muscle. The muscle itself may be pinched, or subjected to galvanic currents, &c.; in this case also contractions are produced. It might be supposed that the contractions so produced are in reality due to the fact that, although the stimulus is apparently applied directly to the muscle, it is, after all, the fine nerve-branches, so abundant in the muscle, which are actually stimulated. The following facts however go far to prove that the muscular fibres themselves are capable of being directly stimulated without the intervention of any nerves. When a frog (or other animal) is poisoned with Curari, the nerves may be subjected to the strongest stimuli without causing any contractions in the muscles to which they are distributed: yet even ordinary stimuli applied directly to the muscle readily cause contractions. If before introducing the Curari into the system, a ligature be passed underneath the sciatic nerve in one leg, for instance the right, and drawn tightly round the whole leg for the exclusion of the nerve, it is evident that the urari, when injected into the back of the animal, will gain access to the right sciatic nerve above the ligature, but not below, while it will have free access to the whole left sciatic. If, as soon as the urari has taken effect, the two sciatic nerves be stimulated, no movement of the left leg will be produced by stimulating the left sciatic, whereas strong contractions of the muscles of the right leg below the ligature will follow stimulation of the right sciatic, whether the nerve be stimulated above or below the ligature. Now since the upper parts of both sciatics are equally exposed to the action of the poison, it is clear that the failure of the left nerve to cause contraction is not attributable to any change having taken place in the upper portion of the nerve, else why should not the right, which has in its upper portion been equally exposed to the action of the poison, also fail? Evidently the poison acts on some parts of the nerve lower down. If a single muscle be removed from the circulation (by ligaturing its blood-vessels), previous to the poisoning with urari, that muscle will contract when any part of the nerve going to it is stimulated, though no other muscle in the body will contract when its nerve is stimulated. Here the whole nerve right down to the muscle has been exposed to the action of the poison; and yet it has lost none of its power over the muscle. On the other hand, if the muscle be allowed to remain in the body, and so be exposed to the action of the poison, but the nerve be cut out high up and gently removed from the body, except where it is

attached to the muscle, so as to be taken away from the influence of the poison, stimulation of the nerve produces no contractions in the muscle, though stimuli applied directly to the muscle at once cause it to contract. From these facts it is clear that urari poisons the ends of the nerve within the muscle long before it affects the trunk, and it is exceedingly probable that it is the very extreme ends of the nerves (possibly the end plates, though we have no definite proof of this), which are affected. The phenomena of urari poisoning therefore go far to prove that muscles are capable of being made to contract by stimuli applied directly to the muscular fibres themselves; and there are other facts which support this view.

This question of 'independent muscular irritability' was once thought to be of importance. In old times, the swelling of a muscle during contraction was held to be caused by the animal spirits descending into it along the nerves; and when the doctrine of 'spirits' was given up, it was still taught that the vital activity of the muscle was something bestowed upon it by the action of the nerve, and not properly belonging to itself. We owe to Haller the establishment of the truth, that the contraction of a muscle is a manifestation of the muscle's own energy, excited it may be by nervous action, but not caused by it. Haller spoke of the muscle as possessing a *vis insita*, while he called the nervous action, which excites contraction, the *vis nervosa*. He used the word irritability as almost synonymous with contractility, a meaning which is still adopted by many authors. In this work we have used it in the wider sense, first employed by Glisson, which includes other manifestations of energy than the change of form which constitutes a contraction. Since Haller's time, the question whether muscles possess an independent irritability has shifted its ground; it now means, not whether muscles are irritable or no, but simply whether their irritability can be called into action in other ways than by the mediation of nerves. In addition to the urari argument just described, we may state that portions of muscular fibres, entirely destitute of nerves, such as the lower end of the sartorius of the frog, may be stimulated directly, with contractions as a result; that the chemical substances which act as stimuli when applied directly to muscles, differ somewhat from those which act as stimuli to nerves, and lastly, that a portion of muscle-fibre quite free from nerves may be seen under the microscope to contract. In the succeeding portions of this work abundant evidence will be afforded that the activity of contractile protoplasm is in no way essentially dependent on the presence of nervous elements.

The Phenomena of a simple Muscular Contraction.

If the far end of the nerve of a muscle-nerve preparation (the gastrocnemius for instance of the frog with the attached sciatic nerve dissected out), Figs. 1 and 2, be laid on the electrodes of an induction-machine, the passage of a single induction-shock (either making or breaking) will produce no visible change in the nerve, but the muscle will give a short sharp contraction, *i.e.* will for an instant shorten itself, becoming thicker the while, and then return to its previous

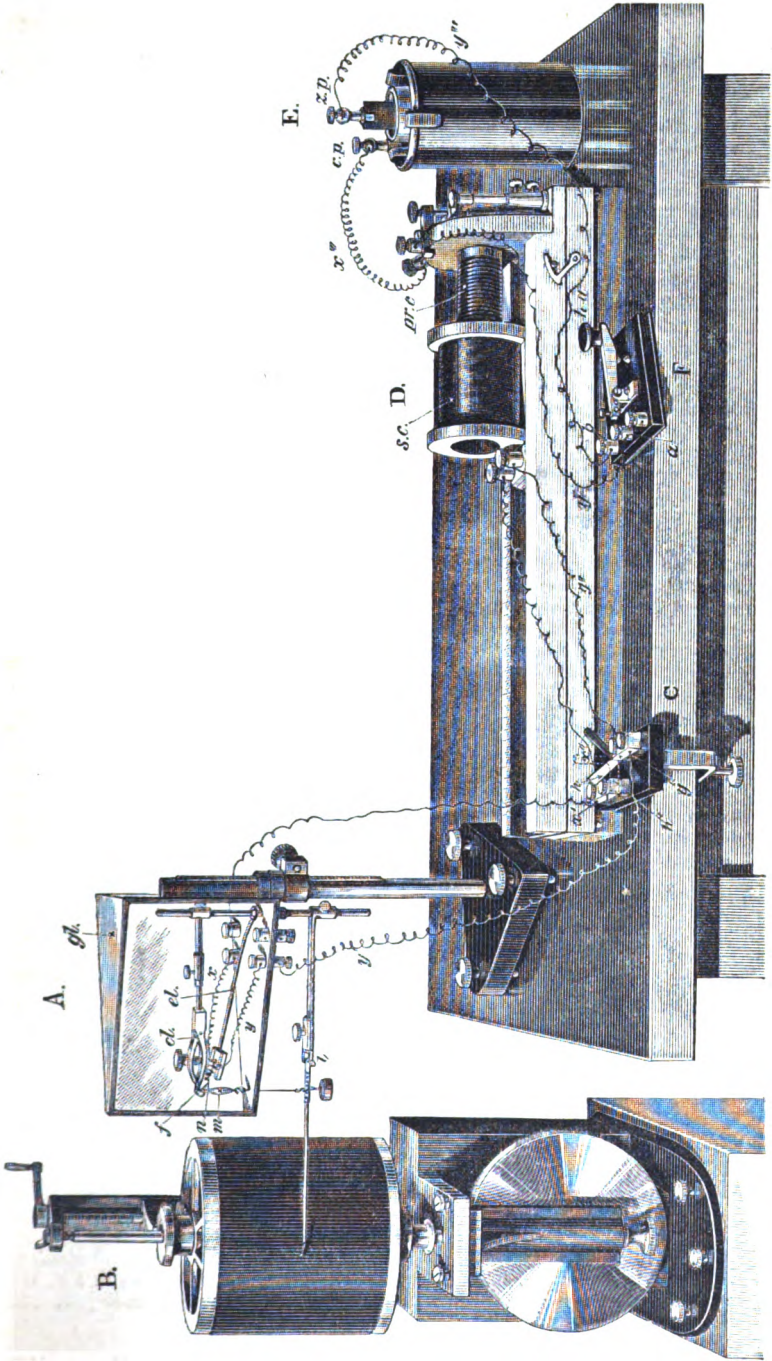

FIG. 1. DIAGRAM ILLUSTRATING APPARATUS ARRANGED FOR EXPERIMENTS WITH MUSCLE AND NERVE.

- A. The moist chamber containing the muscle-nerve preparation. (The muscle-nerve and electrode-holder are shewn on a larger scale in Fig. 2.) The muscle *m*, supported by the clamp *cl*, which firmly grasps the end of the femur *f*, is connected by means of the S hook *s*, and a thread with the lever *l*, placed below the moist chamber. The nerve *n*, with the portion of the spinal column *n'* still attached to it, is placed on the electrode-holder *el*, in contact with the wires *x*, *y*. The whole of the interior of the glass case *gl* is kept saturated with moisture, and the electrode-holder is so constructed that a piece of moistened blotting paper may be placed on it without coming into contact with the nerve.
- B. The revolving cylinder bearing the smoked paper on which the lever writes. A figure of the cylinder from a different point of view is shewn in Fig. 89.
- C. Du Bois-Reymond's key arranged for short circuiting. The wires *x* and *y* of the electrode-holder are connected through binding screws in the floor of the moist chamber with the wires *x'*, *y'*, and these are secured in the key, one on either side. To the same key are attached the wires *x''*, *y''* coming from the secondary coil *s. c.* of the induction-machine *D*. This secondary coil can be made to slide up and down over the primary coil *pr. c.*, with which are connected the two wires *x'''* and *y'''*. *x'''* is connected directly with one pole, for instance the copper pole *c. p.* of the battery *E*. *y'''* is carried to a binding screw *a* of the Morse key *F*, and is continued as *y''''* from another binding screw *b* of the key to the zinc pole *z. p.* of the battery.

Supposing everything to be arranged, and the battery charged, on depressing the handle *h a*, of the Morse key *F*, a current will be made in the primary coil *pr. c.*, passing from *c. p.* through *x'''* to *pr. c.*, and thence through *y'''* to *a*, thence to *b*, and so through *y''''* to *z. p.* On removing the finger from the handle of *F*, a spring thrusts up the handle, and primary circuit is in consequence immediately broken.

At the instant that the primary current is either made or broken, an induced current is for the instant developed in the secondary coil *s. c.* If the cross bar *h* in the Du Bois-Reymond's key be raised (as shewn in the thick line in the figure), the wires *x'*, *x*, the nerve between the electrodes and the wires *y*, *y'*, *y''* form the complete secondary circuit, and the nerve consequently experiences a making or breaking induction-shock whenever the primary current is made or broken. If the cross bar of the Du Bois-Reymond key be shut down, as in the dotted line *h'* in the figure, the resistance of the cross bar is so slight compared with that of the nerve and of the wires going from the key to the nerve, that the whole secondary (induced) current passes from *x''* to *y''* (or from *y''* to *x''*) along the cross bar, and none passes into the nerve. The nerve being thus short circuited, is not affected by any changes in the current.

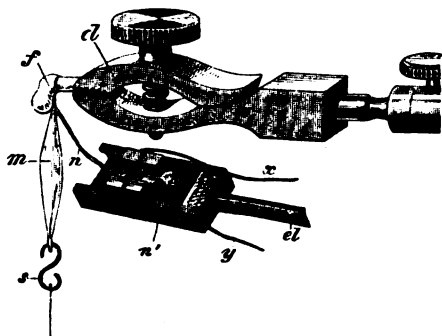

Fig. 2. The muscle-nerve preparation of Fig. 1, with the clamp, electrodes, and electrode-holder are here shewn on a larger scale. The letters as in Fig. 1. The form of electrode-holder figured is a convenient one for general purposes, but many other forms are in use.

condition. If one end of the muscle be attached to a lever, while the other is fixed, the lever will by its movement indicate the extent and duration of the shortening. If the point of the lever be brought to bear on some rapidly travelling surface, on which it leaves a mark (being for this purpose armed with a pen and ink if the surface be plain paper, or with a bristle or needle if the surface be smoked glass or paper), so long as the muscle remains at rest the lever will describe an even line. When, however, a contraction takes place, as when a single induction-shock is sent through the nerve, some such curve as that shewn in Fig. 3 will be described, the lever rising with the

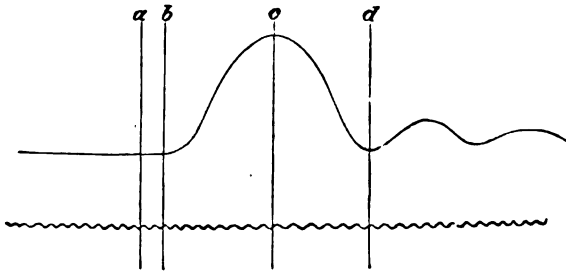

FIG. 3. A MUSCLE-CURVE OBTAINED BY MEANS OF THE PENDULUM MYOGRAPH.
(To be read from left to right.)

a indicates the moment at which the induction-shock is sent into the nerve. *b* the commencement, *c* the maximum, and *d* the close of the contraction. The two smaller curves succeeding the larger one are due to oscillations of the lever.

Below the muscle-curve is the curve drawn by a tuning fork making 180 double vibrations a second, each complete curve representing therefore $\frac{1}{180}$ of a second. It will be observed that the plate of the myograph was travelling more rapidly towards the close than at the beginning of the contraction, as shewn by the greater length of the vibration-curves.

shortening of the muscle, and descending as the muscle returns to its natural length. This is known as the 'muscle-curve.' In order to make the 'muscle-curve' complete, it is necessary to mark on the recording surface the exact time at which the induction-shock is sent into the nerve, and also to note the speed at which the recording surface is travelling. These points are best effected by means of the pendulum myograph, Fig. 4.

In this instrument a smoked glass plate, on which a lever writes, swings with a pendulum. The pendulum with the glass plate attached being raised up, is suddenly let go. It swings of course to the opposite side, the glass plate travels through an arc of a circle, and, the lever being stationary, the point of the lever describes an arc on the glass plate. The rate at which the glass plate travels, *i.e.* the time it takes for the lever-point to describe a line of a given length on the glass plate may be calculated from the length of the pendulum, but it is simpler and easier to place a vibrating tuning-fork immediately under the point of the lever. If the vibrations of the tuning-fork are known, then the number of vibrations which are marked

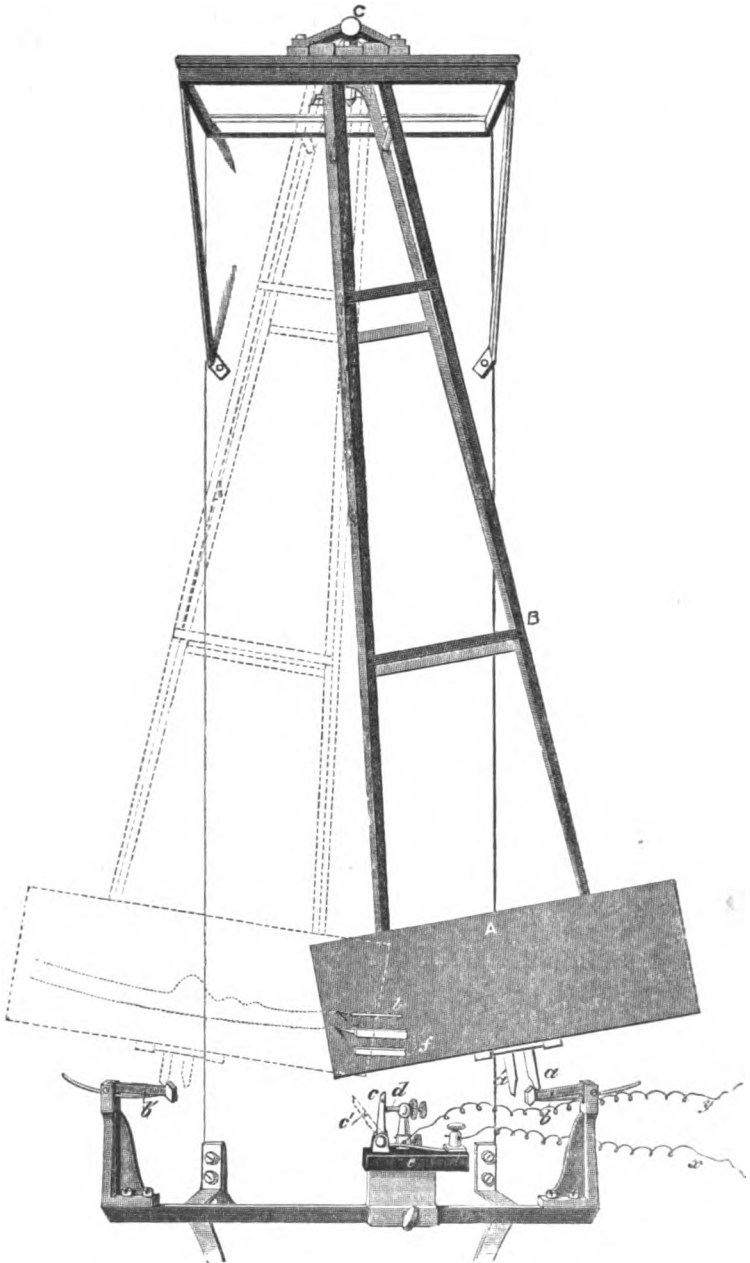

FIG. 4. THE PENDULUM MYOGRAPH.

The figure is diagrammatic, the essentials only of the instrument being shewn. The smoked glass plate *A* swings on the "seconds" pendulum *B* by means of carefully

adjusted bearings at *C*. The contrivances by which the glass plate can be removed and replaced at pleasure are not shewn. A second glass plate so arranged that the first glass plate may be moved up and down without altering the swing of the pendulum is also omitted. Before commencing an experiment the pendulum is raised up (in the figure to the right), and is kept in that position by the tooth *a* catching on the spring-catch *b*. On depressing the catch *b* the glass plate is set free, swings into the new position indicated by the dotted lines, and is held in that position by the tooth *a'* catching on the catch *b'*. In the course of its swing the tooth *a'* coming into contact with the projecting steel rod *c*, knocks it on one side into the position indicated by the dotted line *c'*. The rod *c* is in electric continuity with the wire *x* of the primary coil of an induction-machine. The screw *d* is in similarly electric continuity with the wire *y* of the same primary coil. The screw *d* and the rod *c* are armed with platinum at the points in which they are in contact, and both are insulated by means of the ebonite block *e*. As long as *c* and *d* are in contact the circuit of the primary coil to which *x* and *y* belong is closed. When in its swing the tooth *a'* knocks *c* away from *d*, at that instant the circuit is broken, and a 'breaking' shock is sent through the electrodes connected with the secondary coil of the machine, and so through the nerve. The lever *l*, the end only of which is shewn in the figure, is brought to bear on the glass plate, and when at rest describes a straight line, or more exactly an arc of a circle of large radius. The tuning-fork *f*, the ends only of the two limbs of which are shewn in the figure placed immediately below the lever, serves to mark the time.

on the plate between any two points on the line described by the lever gives the time taken by the lever in passing from one point to the other. An easy arrangement permits the exact time at which the shock is sent through the nerve to be marked on the line of the lever. To avoid too many markings on the plate the pendulum after describing an arc is caught by a spring catch on the opposite side.

A complete muscle-curve, such as that shewn in Fig. 3, teaches us the following facts:

1. That although the passage of the induced current from electrode to electrode is practically instantaneous, its effect, measured from the entrance of the shock into the nerve to the return of the muscle to its natural length after the shortening, takes an appreciable time. In the figure, the whole contraction from *a* to *d* takes up the same time as eighteen double vibrations of the tuning-fork. Since each double vibration represents $\frac{1}{180}$ of a second, the duration of the whole contraction figured was $\frac{1}{10}$ sec.

2. In the first portion of this period, from *a* to *b*, there is no visible change, no shortening of the muscle, no raising of the lever.

3. It is not until *b*, that is to say after the lapse of $\frac{2\frac{1}{2}}{180}$ i. e. about $\frac{1}{72}$ sec., that the shortening begins. The shortening as shewn by the curve is at first slow, but soon becomes more rapid, and then slackens again until it reaches a maximum at *c*; the whole shortening occupying about $\frac{1}{30}$ sec.

4. Arrived at the maximum of shortening, the muscle at once begins to relax, the lever descending at first slowly, then very rapidly, and at last more slowly again, until at *d* the muscle has regained its natural length; the whole return from the maximum of contraction to the natural length occupying $\frac{7}{180}$, i. e. about $\frac{1}{30}$ sec.

Thus a simple muscular contraction, a simple spasm as it is sometimes called, produced by a momentary stimulus, such as an instantaneous induction-shock, consists of three main phases.

1. A phase antecedent to any visible alteration in the muscle. This phase, during which invisible preparatory changes are taking place in the nerve and muscle, is often called the 'latent period.'
2. A phase of shortening or contraction.
3. A phase of relaxation or return to the original length.

In the case we are considering, the electrodes are supposed to be applied to the nerve at some distance from the muscle. Consequently the latent period of the curve comprises not only the preparatory actions going on in the muscle itself, but also the changes necessary to conduct the immediate effect of the induction-shock from the part of the nerve between the electrodes, along a considerable length of nerve down to the muscle. It is obvious that these latter changes might be eliminated by placing the electrodes on the muscle itself or on the nerve close to the muscle. If this were done, the muscle and lever being exactly as before, and care were taken that the induction-shock entered into the nerve at the new spot, at the moment when the point of the lever had reached exactly the same point of the travelling surface as before, a curve like that shewn by the plain line in Fig. 5 would be gained. It resembles the first curve (indicated in the figure by a dotted line) in all points, except that the

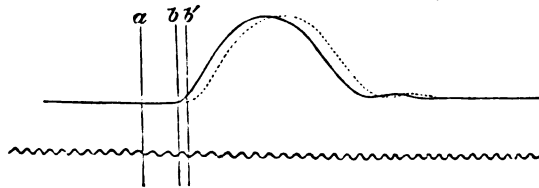

FIG. 5. CURVES ILLUSTRATING THE MEASUREMENT OF THE VELOCITY OF A NERVOUS IMPULSE. (Diagrammatic.) To be read from left to right.

The same muscle-nerve preparation is stimulated (1) as far as possible from the muscle, (2) as near as possible to the muscle; both contractions are registered by the pendulum myographion exactly in the same way.

In (1) the stimulus enters the nerve at the time indicated by the line *a*, the contraction, shewn by the dotted line, begins at *b'*; the whole latent period therefore is indicated by the distance from *a* to *b'*.

In (2) the stimulus enters the nerve at exactly the same time *a*; the contraction, shewn by the unbroken line, begins at *b*; the latent period therefore is indicated by the distance between *a* and *b*.

The time taken up by the nervous impulse in passing along the length of nerve between 1 and 2 is therefore indicated by the distance between *b* and *b'*, which may be measured by the tuning-fork curve below. N.B. No value is given in the figure for the vibrations of the tuning-fork, since the figure is diagrammatic, the distance between the two curves, as compared with the length of either, having been purposely exaggerated for the sake of simplicity.

latent period is shortened; the contraction begins rather earlier. From this we learn two facts.

1. The greater part of the latent period is taken up by changes in the muscle itself, preparatory to the actual visible shortening, for the two latent periods do not differ much. Of course, even in the second case, the latent period includes the changes going on in the short piece of nerve still lying between the electrodes and the muscular fibres. To eliminate this with a view of determining the latent period in the muscle itself, the electrodes should be placed directly on the muscle poisoned with urari. If this were done, it would still be found that the latent period was chiefly taken up by changes in the muscular as distinguished from the nervous elements.

2. Such difference as does exist indicates the time taken up by the propagation, along the piece of nerve, of the changes set up at the far end of the nerve by the induction-shock. These changes we shall hereafter speak of, as constituting a nervous impulse; and the above experiment shews that it takes some appreciable time for a nervous impulse to travel along a nerve. In the figure the difference between the two latent periods, the distance between b and b' , seems almost too small to measure accurately; but if a long piece of nerve be used for the experiment, and the recording surface be made to travel very fast, the difference between the duration of the latent period when the induction-shock is sent in at a point close to the muscle, and that when it is sent in at a point as far away as possible from the muscle, may be satisfactorily measured in fractions of a second. If the length of nerve between the two points be accurately measured, the rate at which a nervous impulse travels along the nerve to a muscle can be easily calculated. This has been found to be in the frog about 28, and in man about 33 metres per second.

Thus when a momentary stimulus, such as a single induction-shock, is sent into a nerve connected with a muscle, the following events take place.

1. The creation at the spot stimulated of a nervous impulse, and the propagation of the impulse along the nerve to the muscle. The time taken up by this varies according to the length of the nerve. For the same length of nerve it is tolerably constant.

2. The setting up of certain molecular changes in the muscle, unaccompanied by any visible alteration in its form, constituting the latent period, and occupying on an average about $\frac{1}{100}$ th sec. The time taken up by the latent period varies somewhat according to circumstances.

3. The shortening of the muscle up to a maximum, occupying about $\frac{4}{100}$ sec.

4. The return of a muscle to its former length, occupying about

$\frac{5}{100}$ sec. Both these last events vary much in duration according to circumstances¹.

Tetanic Contractions.

If a single induction-shock be followed at a sufficiently short interval by a second shock of the same strength, the first simple contraction or spasm will be followed by a second spasm, the two bearing some such relation to each other as that shown by the curve in Fig. 6, where the interval between the two shocks was just long

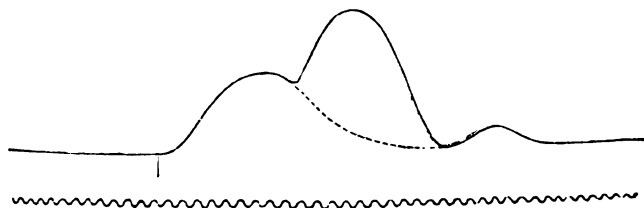

FIG. 6. TRACING OF A DOUBLE MUSCLE CURVE. To be read from left to right.

While the muscle was engaged in the first contraction (whose complete course, had nothing intervened, is indicated by the dotted line), a second induction-shock was thrown in, at such a time that the second contraction began just as the first was beginning to decline. The second curve is seen to start from the first as does the first from the base-line.

enough to allow the first spasm to have passed its maximum before the latent period of the second was over. It will be observed that the second curve is almost in all respects like the first except that it starts, so to speak, from the first curve instead of from the base-line. The second nervous impulse has acted on the already contracted muscle, and made it contract again just as it would have done if there had been no first impulse and the muscle had been at rest. The two contractions are added together and the lever raised nearly double the height it would have been by either alone. A more or less similar result would occur if the second contraction began at any other phase of the first. The combined effect is, of course, greatest when the second contraction begins at the maximum of the first, being less both before and afterwards. If in the same way a third shock follows the second at a sufficiently short interval, a third curve is piled on the top of the second. The same with a fourth, and so on.

When however repeated shocks are given it is found that the height of each contraction is rather less than the preceding one, and this diminution becomes more marked the greater the number of shocks. Hence after a certain number of shocks, the succeeding impulses do

¹ The measurements here stated are those ordinarily given. The curve described in the previous text happened to have a rather long latent period, and the lengthening to be of shorter instead of longer duration than the shortening.

not cause any further shortening of the muscle, any further raising of the lever, but merely keep up the contraction already existing. The curve thus reaches a maximum which it maintains, subject to the depressing effects of exhaustion, as long as the shocks are repeated. When these cease to be given, the muscle returns, in the usual way, at first very rapidly, and then more slowly, to its natural length. When the shocks do not succeed each other too rapidly, the individual contractions may readily be traced along the whole curve, as is seen in Fig. 7, where the primary current of the induction-machine

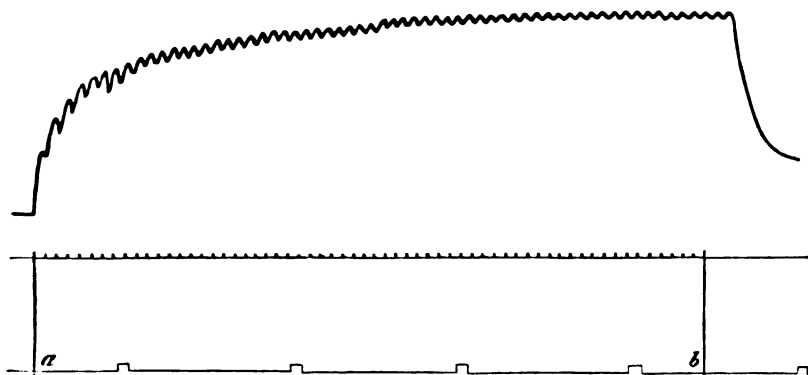

FIG. 7. MUSCLE THROWN INTO TETANUS, WHEN THE PRIMARY CURRENT OF AN INDUCTION-MACHINE IS REPEATEDLY BROKEN AT INTERVALS OF SIXTEEN IN A SECOND.
To be read from left to right.

The upper line is that described by the muscle. The lower marks time, the intervals between the elevations indicating seconds. The intermediate line shews when the shocks were sent in, each mark on it corresponding to a shock. The lever, which describes a straight line before the shocks are allowed to fall into the nerve, rises almost vertically (the recording surface travelling in this case slowly) as soon as the first shock enters the nerve at *a*. Having risen to a certain height, it begins to fall again, but in its fall is raised once more by the second shock, and that to a greater height than before. The third and succeeding shocks have similar effects, the muscle continuing to become shorter, though the shortening at each shock is less. After a while the increase in the total shortening of the muscle, though the individual contractions are still visible, almost ceases. At *b*, the shocks cease to be sent into the nerve; the contractions almost immediately disappear, and the lever forthwith commences to descend. The muscle being lightly loaded, the descent is very gradual; the muscle had not regained its natural length when the tracing was stopped.

was repeatedly broken at intervals of sixteen in a second. When the shocks succeed each other more rapidly, the individual contractions, visible at first, may become fused together and lost to view as the tetanus continues and the muscle becomes tired. When the shocks succeed each other still more rapidly (the second contraction beginning in the ascending portion of the first), it becomes difficult or impossible to trace out the single contractions. The curve then described by the lever is of the kind shewn in Fig. 8, where the primary current of an induction-machine was rapidly made and broken by the magnetic interruptor,

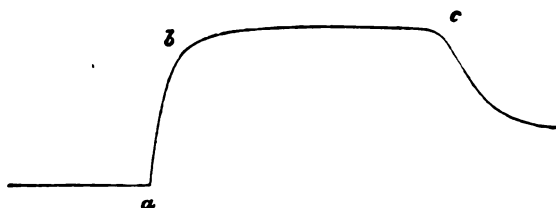

FIG. 8. TETANUS PRODUCED WITH THE ORDINARY MAGNETIC INTERRUPTOR OF AN INDUCTION-MACHINE. (RECORDING SURFACE TRAVELLING SLOWLY.) To be read from left to right.

The interrupted current being thrown in at *a* the lever rises rapidly, but at *b* the muscle reaches the maximum of contraction. This is continued till *c*, when the current is shut off and relaxation commences.

Fig. 9. The lever, it will be observed, rises at *a* after the latent period (which is not marked), first rapidly, and then more slowly, in an apparently unbroken line to a maximum at about *b*, maintains the maximum, subject to the effects of exhaustion, so long as the shocks continue to be given, and when these cease to be given, as at *c*, gradually descends to the base-line. This condition of muscle, brought about by rapidly repeated shocks, this fusion of a number of simple spasms into an apparently smooth, continuous effort, is known as *tetanus*, or *tetanic contraction*. The above facts are most clearly shewn when induction-shocks, or at least galvanic currents in some form or other, are employed. They are seen, however, whatever be the form of stimulus employed. Thus in the case of mechanical stimuli, a single blow given to a nerve may cause a single spasm, repeated blows (if frequent enough) a tetanus. With chemical stimulation, as when a nerve is dipped in acid, it is impossible to secure a momentary application; hence tetanus, generally irregular in character, is the normal result of this mode of stimulation. In the living body, the contractions of the striated muscles, brought about either by the will or by reflex action, are generally tetanic in character. Even very short sharp movements, such as a sudden jerk of the limbs, are in reality examples of tetanus of short duration.

Such being the general visible characters of muscular contractions, we may now attack the questions: What changes in a nerve constitute a nervous impulse? What changes in a muscle constitute a muscular contraction?

Changes in a Nerve during the passage of a nervous impulse.

These are of the same nature during the passage of either a single impulse leading to a simple muscular spasm, or repeated impulses leading to tetanus, the latter being merely an accumulation of the former.

1. There are no visible events.

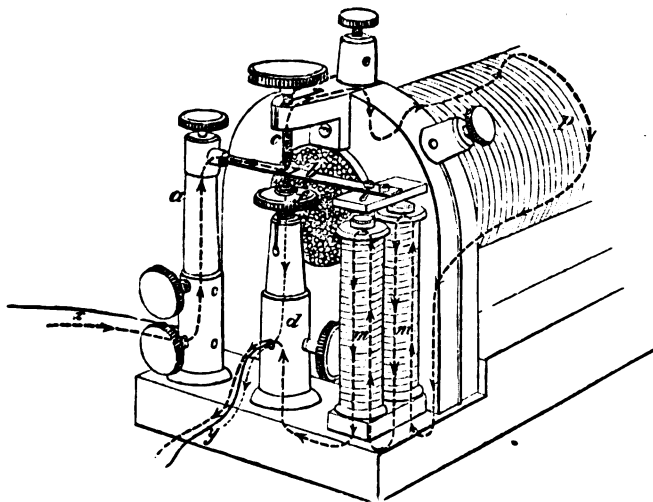

FIG. 9. THE MAGNETIC INTERRUPTOR.

The figure is introduced to illustrate the action of this instrument as commonly used by physiologists.

The two wires *x* and *y* from the battery are connected with the two brass pillars *a* and *d* by means of screws. Directly contact is thus made the current, indicated in the figure by the *thick* interrupted line, passes in the direction of the arrows, up the pillar *a*, along the steel spring *b*, as far as the screw *c*, the point of which, armed with platinum, is in contact with a small platinum plate on *b*. The current passes from *b* through *c* and a connecting wire into the primary coil *p*. Upon its entering into the primary coil, an induced (making) current is for the instant developed in the secondary coil (not shewn in the figure). From the primary coil *p* the current passes, by a connecting wire, through the double spiral, *m*, and, did nothing happen, would continue to pass from *m* by a connecting wire to the pillar *d*, and so by the wire *y* to the battery. The whole of this course is indicated by the *thick* interrupted line with its arrows.

As the current however passes through the spirals *m*, the iron cores of these are made magnetic. They in consequence draw down the iron bar *e*, fixed at the end of the spring *b*, the flexibility of the spring allowing this. But when *e* is drawn down, the platinum plate on the upper surface of *b* is also drawn away from the screw *c*, and a similar platinum plate on the *under* surface of *b* is brought into contact with the platinum armed point of the screw *f*, the screws being so arranged that this takes place. In consequence of this change the current can no longer pass from *b* to *c*. On the contrary, it passes from *b* to *f*, and so down the pillar *d*, in the direction indicated by the *thin* interrupted line, and out to the battery by the wire *y*. Thus the current is "short-circuited" from the primary coil; and the instant that the current is thus cut off from the primary coil, an induced (breaking) current is for the moment developed in the secondary coil. But the current is cut off not only from the primary coil, but also from the spirals *m*; in consequence their cores cease to be magnetized, the bar *e* ceases to be attracted by them, and the spring *b*, by virtue of its elasticity, resumes its former position in contact with the screw *c*. This return of the spring however re-establishes the current in the primary coil, and in the spirals, and the spring is drawn down, to be released once more in the same manner as before. Thus as long as the current is passing along *x*, the contact of *b* is constantly alternating between *c* and *f*, and the current is constantly passing into and being shut off from *p*, the periods of alternation being determined by the periods of vibration of the spring *b*. With each passage of the current into, or withdrawal from the primary coil, an induced (making and, respectively, breaking) shock is developed in the secondary coil.

2. No chemical changes have been satisfactorily made out.
3. No change in temperature or in the general physical conditions of the nerve have been satisfactorily observed.
4. The only distinctly appreciable change is an electric one.

Natural nerve-currents. If a piece of living nerve be placed on a pair of non-polarisable¹ electrodes, connected with a sensitive galvanometer containing many convolutions, deflections of the galvanometer-needle indicate the existence of currents which vary according to the position of the electrodes. The greatest deflection is observed when one electrode is placed at the mid-point or equator* of the piece of nerve, and the other at either cut end; and the deflection is of such a kind as to show that positive currents are continually passing from the mid-point through the galvanometer to the cut end, that is to say, the cut end is negative relatively to the mid-point. The currents outside the nerve may be considered as completed by currents *in the nerve* from the cut end to the mid-point. Thus in the diagram Fig. 11, the arrows indicate the direction of the currents. If the one electrode be placed at the equator *ab*, the effect is the same at whichever

¹ These (Fig. 10) consist essentially of a slip of thoroughly amalgamated zinc dipping into a saturated solution of zinc sulphate, which in turn is brought into connection

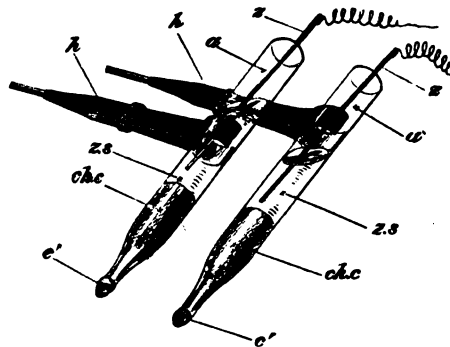

FIG. 10. NON-POLARISABLE ELECTRODES.

a, the glass tube; *z*, the amalgamated zinc slips connected with their respective wires; *z, s*, the zinc sulphate solution; *ch. c.*, the plug of china clay; *c'*, the portion of the china-clay plug projecting from the end of the tube; this can be moulded into any required form.

with the nerve or muscle by means of a plug or bridge of china-clay moistened with dilute sodium chloride solution; it is important that the zinc should be thoroughly amalgamated. This form of electrodes gives rise to less polarisation than do simple platinum or copper electrodes. The clay affords a connection between the zinc and the tissue which neither acts on the tissue nor is acted on by the tissue. Contact of any tissue with copper or platinum is in itself sufficient to develop a current.

² The transverse line containing all the mid-points, *i.e.* points midway between the two ends of the piece, is called the 'equator.' In the diagram, Fig. 11, the line *ab* is the equator.

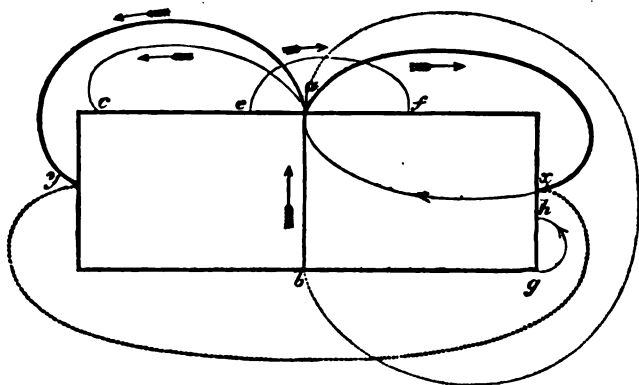

FIG. 11. DIAGRAM ILLUSTRATING THE ELECTRIC CURRENTS OF NERVE AND MUSCLE.

Being purely diagrammatic, it may serve for a piece either of nerve or of muscle, except that the currents at the transverse section cannot be shewn in a nerve. The arrows shew the direction of the current through the galvanometer.

ab the equator. The strongest currents are those shewn by the dark lines, as from *a*, at equator, to *x* or to *y* at the cut ends. The current from *a* to *c* is weaker than from *a* to *y*, though both, as shewn by the arrows, have the same direction. A current is shewn from *e*, which is near the equator, to *f* which is farther from the equator. The current (in muscle) from a point in the circumference to a point nearer the centre of the transverse section is shewn at *gh*. From *a* to *b* or from *x* to *y*, there is no current, as indicated by the dotted lines.

of the two cut ends *x* or *y* the other is placed. If, one electrode remaining at the equator, the other be shifted from the cut end to a spot *c* nearer to the equator, the current continues to have the same direction, but is of less intensity in proportion to the nearness of the electrodes. If the two electrodes be placed at unequal distances *e* and *f*, one on either side of the equator, there will be a feeble current from the one nearer the equator to the one farther off, and the current will be the feebler, the more nearly they are equidistant from the equator. If they are quite equidistant, as for instance when one is placed on one cut end *x*, and the other on the other cut end *y*, there will be no current at all. These currents are spoken of as the natural nerve-currents. They are not transitory, they do not disappear immediately after they have manifested themselves, but on the contrary continue for an indefinite period. They must therefore be maintained by changes taking place within the nerve. Hence they depend on the vital (nutritive) condition of the nerve.

Du Bois-Reymond¹ found the electromotive force of the sciatic nerve of a frog to amount to '022 Daniell, while that of the rabbit did not exceed '026 Daniell. Engelmann² however obtained for the sciatic of the frog a value of '046 Daniell.

¹ *Gesammelt: Abhand.* (1877) II. 232.

² *Pfüger's Archiv*, xv. (1877), p. 141.

Negative variation. When a nerve is stimulated, so that a nervous impulse passes along it, the natural nerve-current is diminished; it undergoes what is called a *negative variation*. This is not easily shewn in the case of a simple impulse, but is very evident when the repeated impulses of tetanus are generated. Thus if in a long piece of nerve, one electrode be placed at one cut end and the other at some distance from it, so as to give a well-marked deflection of the galvanometer, and the other end of the nerve be tetanized with the induction-machine working with a magnetic interruptor, the needle of the galvanometer which before the stimulation was deflected, say to 60 or 70 divisions of the scale on one side of zero, will now swing back considerably towards or to zero or even to some distance on the other side of zero. A similar negative variation is observed wherever the electrodes be placed, and whatever point be stimulated. The effect is not due to any escape from the stimulating current on to the electrodes, for it ceases when the nerve is tied between the point stimulated and the electrodes, yet the ligature does not interfere with the physical conduction of a current along the nerve, though it puts an end to the propagation of vital changes. Moreover the same negative variation is seen whatever be the mode of stimulation. It is not confined especially to electrical stimulation, but occurs also when chemical or mechanical stimuli are used. The negative variation, like the natural current, is a vital phenomenon, and the intensity of both ebbs and flows with the changing vitality of the nerve.

According to Bernstein¹ the deflection of the needle occurring during the negative variation may on very strong stimulation amount to two or three times the deflection due to the natural current.

When we come to study the changes which take place in a muscle during contraction we shall see that the nerve and muscle of a frog may be used instead of a galvanometer, by the method known as 'the rheoscopic frog', in which the natural current of one nerve, or the negative variation of that current, is used as stimulus to another nerve. And we shall learn from that experiment that when a nerve is tetanized, its natural current undergoes not a single, but a series of negative variations, each impulse in fact producing its own variation, so that repeated stimuli, corresponding in number to the variations, are thrown into the second nerve, and thus cause a tetanus in the attached muscle. This fact we cannot learn from the galvanometer, in which the needle from its inertia cannot follow rapidly enough the variations of the current, but gives one large swing which is the accumulation of the smaller swings due to the individual variations, just as the apparently continuous contraction of a tetanized muscle is the summation of a number of simple spasms.

The main event then accompanying a nervous impulse of which

¹ *Untersuch. u. d. Erregungsvorgang im Nerven- und Muskelsysteme.* 1871.

² See p. 53.

we are at present cognisant, is the negative variation of the natural nerve-current. Beyond the terminal effects of a muscular contraction (in motor nerves and corresponding effects in sensory nerves), this is the one token we possess whereby we can judge of what is taking place in a nerve.

By the help of an ingenious apparatus Bernstein¹ has been able to study the way in which the negative variation passes over any given spot in a nerve. Suppose a nerve is stimulated with a single induction-shock at the point *A*; and suppose the points *B*, *B'*, of the nerve, at some distance from *A*, so chosen that they will give a natural nerve-current, are connected with a galvanometer. If the electrodes of *B*, *B'* are permanently connected with the galvanometer, a negative variation will be observed every time *A* is stimulated. But suppose that the points *B*, *B'*, instead of being permanently connected with the galvanometer, are only brought into connection with it for an instant, and that at different small fractions of a second after *A* is stimulated; so that for instance on one occasion, the portion of nerve between *B* and *B'* is brought into momentary connection with the galvanometer—is, as the telegraph engineers would say, 'tapped,'—at the very instant *A* is being stimulated; and on another occasion, at an interval say of $\frac{1}{100}$ sec. after *A* was stimulated, and so on; what should we expect to happen in reference to the nerve-current between *B* and *B'*? This Bernstein investigated. Instead however of simply stimulating *A* once only on each occasion, he repeated the stimulation several times a second, bringing *B*, *B'* into momentary connection with the galvanometer at each stimulation. He thus had under his notice not the slight and probably hardly recognisable effect of a single stimulation, but the cumulative effect of several stimulations, the nerve being 'tapped' at exactly the same fraction of a second after the stimulation in each series of stimulations. By varying the interval in a number of series of stimulations, his apparatus consisting mainly of a revolving disc with moveable adjuncts, he was able to explore the condition of the natural current and the amount of negative variation at *B*, *B'* during the whole interval between any two successive stimulations of *A*. He found that if *B* were tapped at the same instant that the shock passed through *A*, there was no negative variation at all of the natural current. When *B* was tapped a very small fraction of a second later a slight variation was observed, a little later still the variation was found to be greater, still later it had reached a maximum; beyond this it began to decline, and so at last an interval was reached, at which the negative variation was again wholly absent. It had in fact in this last case passed over *B*, before *B* was tapped. These observations shew that the negative variation passes over any given spot of the nerve in the form of a wave, rising rapidly to a maximum and then more gradually declining again. Bernstein found that it travelled in the nerves of the frog at about the rate of 28 metres in a second, a rate identical, it will be noted, with that of the nervous impulse determined in quite other ways. He also found that the whole wave took 0007 sec. to pass over any given point in a nerve. Consequently the length of the wave was about 18 mm.

Assuming, as we fairly may do, that the negative variation is a satisfactory sign of the whole set of changes which constitute a nervous impulse,

¹ *Op. cit.*

we may say that a nervous impulse is a molecular disturbance propagated along the nerve in the form of a wave, of the length, and possessing the velocity, mentioned above.

The Changes in a Muscle during contraction.

Electrical changes. These deserve to be considered apart from the rest, because they alone are definitely known to occur in the latent period. A living muscle exhibits natural muscle-currents altogether similar to the natural nerve-currents but far more powerful. The diagram, Fig. 11, applies to muscle as well as to nerve. In a cylindrical or prismatic muscle with regularly disposed parallel fibres the equator is positive relatively to either end or to points between the end and the equator; and points on either side of the equator are positive or negative the one to the other, according to their distance from the equator. The muscle-currents are obtained not only from muscles still retaining their natural tendinous terminations, but also, and even in a more striking degree, from muscles the ends of which have been cut off, thus presenting terminal artificial transverse sections instead of the natural tendinous ones. In these, moreover, it is seen that the circumference of the transverse section is positive relatively to the centre, as shewn at *g* to *h* in Fig. 11. (In nerves this is not satisfactorily seen.) Thus, of all the points of a muscle the centre of either terminal transverse section and any point on the equator of the muscle are the most negative and positive relatively to each other. The currents are shewn not only with artificial transverse sections, but also with artificial longitudinal sections. In fact, in a mere piece of muscle the same distribution of currents may be witnessed.

Du Bois-Reymond¹ finds the electromotive force of the natural current of a frog's muscle (*gracilis* or *semimembranosus*) to amount sometimes to .08 Daniell. That of the muscle of a rabbit never exceeded .049 Daniell.

It has been said that the currents in a muscle with artificial transverse sections are often more marked than those of an intact muscle. In fact, frequently when a muscle is removed with extreme care from the body, and the tendinous origins and insertions allowed to remain bathed in their natural lymph, the currents observed are very feeble indeed or even wholly absent. On dipping the tendon in acid or water however, strong currents are at once developed. To explain this Du Bois-Reymond supposes that the extreme end of the muscle is in the natural condition protected by a layer of positive elements whose action masks the natural current. It is not until this *parelectronic layer*, as he calls it, has been removed by the application of some reagent or by changes taking place in the muscle itself, that the natural current can manifest itself in its proper strength. Hermann, on the other hand, regards the absence of currents as the natural condition of the muscle (or nerve). He explains the current obtained with

¹ *Gesammelte Abhandl.* ii. 242.

the artificial transverse section as due to the exposed layer of muscular (or nervous) substance, as it dies or enters into rigor mortis, becoming negative relatively to the still living substance. Where natural currents are manifested in untouched muscles, the terminal portions of the fibres may be supposed to be dying in advance of the median portions. Under this view the negative variation during contraction (of which we shall speak directly) is of course to be regarded as an independent current generated by the molecules of the muscular substance becoming negative during the latent period, the negativity sweeping along the fibre in advance of the contraction-wave. Engelmann¹ has brought forward a strong support of Hermann's view, by shewing that in the heart, unstriated muscles, and nerves, the current produced by a recently prepared artificial section sinks in the course of some hours almost to nil, but may be revived to its original strength by a fresh section slightly in advance of the old one. In the present state of our knowledge, there are many difficulties in the way of accepting either one view or the other, and a discussion of the subject sufficiently exhaustive to be of any value would be beyond the scope of this work. The reader who wishes to enter more fully into the matter is referred to the memoirs contained in Du Bois-Reymond, *Gesammelte Abhandlungen*, 1875—77, Hermann, *Untersuch. zur Physiol. d. Muskeln und Nerven*, 1867—68, and numerous papers in Pflüger's *Archiv*.

The currents are in part dependent on the form of the muscle or piece of muscle. Thus in a rhomb the blunt angles are positive towards the acute ones, and the natural currents are obscured by currents, the so-called *currents of inclination*, passing from the latter to the former. Hence the scheme of natural currents, illustrated by the diagram, Fig. 11, only holds good for regular muscles, the fibres of which are all parallel, ending in tolerably rectangular terminations. In an irregular muscle, such as the gastrocnemius, for instance, in which the currents of inclination are very pronounced, the diagrammatic representation of the various currents gives a complicated figure wholly unlike Fig. 11².

During a contraction the natural muscle-current undergoes a negative variation. Not easily seen in a single spasm, this is exceedingly obvious during tetanus. If a pair of electrodes be placed on a muscle, one at the equator, and the other at or near the transverse section, and thus a considerable deflection of the galvanometer be gained, indicating a considerable natural current, the needle of the galvanometer will, when the muscle is tetanized by an interrupted current sent through its nerve (at a point too far from the muscle to allow any escape of the current into the electrodes connected with the galvanometer), swing back towards zero; it returns to its original deflection when the tetanizing current is shut off.

This negative variation may not only be shewn by the galvanometer, but it, as well as the natural current, may be used as a galvanic shock and so employed to stimulate a muscle, as in the experiment known as 'the rheoscopic frog.' For this purpose sensitive muscles and nerves in thoroughly good condition are required. Two muscle-

¹ Pflüger's *Archiv*, xv. (1877), p. 116, p. 328.

² Cf. Du Bois-Reymond, *op. cit.* ii. 63.

nerve preparations having been made and each placed on a glass plate for the sake of insulation, the nerve of the one is allowed to fall on the muscle of the other in such a way that one point of the nerve comes in contact with the equator of the muscle, and another point with one end of the muscle or with a point at some distance from the equator. At the moment the nerve is let fall and contact made, a current passes through the nerve; this acts as a stimulus to the muscle connected with the nerve, and causes contraction in it. So the muscle *A* acts as a battery, the completion of the current of which by means of the nerve of *B*, serves as a stimulus, causing *B* to contract.

If while the nerve of *B* is still in contact with the muscle of *A*, the nerve of the latter is tetanized with an interrupted current, not only is the muscle of *A* thrown into tetanus but also that of *B*; the reason being as follows. At each spasm of which the tetanus of *A* is made up, there is a negative variation of the muscle-current of *A*. Each negative variation in the muscle of *A* serves as a stimulus to the nerve of *B*, and is hence the cause of a spasm in the muscle of *B*; and the stimuli following each other rapidly as they must do being produced by tetanus of *A*, the spasms in *B* to which they give rise are also fused into a tetanus in *B*. *B* in fact contracts in harmony with *A*. This experiment shews that the negative variation accompanying the tetanus of a muscle, though it causes only a single movement of the galvanometer, is really made up of a series of negative variations, each single negative variation corresponding to the single spasms of which the tetanus is made up.

Similar results are arrived at, though less readily, if the nerve of *B*, instead of being allowed to fall on the muscle of *A*, is placed in contact with two points of the nerve of *A*, so situate as to develop a current. When the nerve of *B* is let fall on the two points of the nerve of *A*, so chosen that a nerve-current may be expected to pass between them, a single spasm, caused by the completion or making of the circuit of the nerve-current, may sometimes be observed in the muscle of *B*. When the nerve of *A* is tetanized with an interrupted current, the muscle of *B* is thrown into tetanus; in these cases it is the natural current (or its variation) of the nerve and not of the muscle, which acts as a stimulus.

The negative variation falls entirely within the latent period. It is over and gone before the actual shortening commences. It is in fact a token of something like a nervous impulse passing over the muscular fibre as a forerunner of the events which lead to a change of form.

Bernstein¹ has studied the history of this negative variation in muscle. He finds that it, like the negative variation in the nerve, travels in the form of a wave, with a velocity of about 3 metres. It is about $\frac{1}{300}$ second in passing over any given point, and therefore has a wave-length of about 10 mm. Compared with the nerve-wave, therefore, it is much shorter

¹ *Op. cit.*

and slower. These results were obtained by stimulating directly one end of a long muscle poisoned with urari in order to eliminate the nerves (see p. 35). The impulse then travelled away from the end stimulated along the whole length of the muscle. (When the muscle is stimulated through a nerve, the impulse starts from the end-plates, often situated in the middle of a fibre, and proceeds in both directions, up and down. Such a condition would be most unfavourable for studying the progress of the impulse.) We learn from this that there passes over the muscle, in the latent period before any change of form takes place, an impulse-wave, not unlike a nervous impulse and yet distinctly differing from it. In its steepness and sluggishness the wave foreshadows the motor changes it is about to inaugurate.

Contrary to the case of a nerve, Bernstein found that, in a muscle, when the natural current was obtained by help of an artificial transverse section, the deflection indicating the negative variation never exceeded the deflection of the natural current. The effect of the natural current might be reduced to nil, but the needle was never carried, as it might be in a nerve, a long way the other side of zero.

2. Change of Form. At the close of the latent period the muscle shortens, that is, each fibre shortens, at first slowly, then more rapidly, and lastly more slowly again. The shortening (which in severe tetanus may amount to three-fifths of the length of the muscle) is accompanied by an almost exactly corresponding thickening, so that there is hardly any actual change in bulk. If a muscle be placed horizontally, and a lever laid upon it, the thickening of the muscle will raise up the lever, and cause it to describe on a recording surface a curve exactly like that described by a lever attached to the end of the muscle. There appears to be a minute diminution of bulk not amounting to more than one thousandth.

If a long muscle of parallel fibres, poisoned with urari, so as to eliminate the action of its nerves, be stimulated at one end, the contraction may be seen, almost with the naked eye, to start from the end stimulated, and to travel along the muscle. If two levers be made to rest on, or be suspended from two points of such a muscle placed horizontally, the points being at a known distance from each other and from the point stimulated, the progress of the contraction may be studied. It is found that the contraction, like the preceding impulse, passes along the muscle in the form of the wave, with a velocity in the frog of about 3 or 4 (3·869) metres in a second; its duration at any given point varies from ·0533 to ·0984, and hence it possesses a wave-length of from 198—380 mm. This statement is taken from Bernstein¹. Hermann² makes the rate about 3 metres. Aeby previously had given ·8—1·2 metres per sec., and Engelmann 1·17 m. per sec. as the velocity. The slowness and the enormous length of this contraction-wave place it in strong contrast with the impulse-wave. Seeing that the extreme limit of the length of a muscular fibre is about 3 to 4 cm., it is evident that in an ordinary contraction, even when the stimulation begins at one end, the whole fibre is not only in a state of contraction at the same

¹ *Op. cit.* See also Du Bois-Reymond's *Archiv*, 1875, 526.

² Pflüger's *Archiv*, x. (1875), 48.

time, but almost in the same phase of the contraction-wave. Still more is this the case when, as in ordinary stimulation through a nerve, the contraction begins at or near the middle of a fibre in an end-plate, or at two points (end-plates) of the same fibre at the same time. Nevertheless the length of the contraction-wave must vary within very wide limits. Thus in muscles examined under the microscope exceedingly short waves occupying only a small portion of the length of a fibre are frequently witnessed. These however may be regarded as the abnormal results of exhaustion and commencing death.

A muscle in the body, or one out of the body when sufficiently loaded, returns after the contraction completely to its former length. Out of the body and unloaded, it generally falls somewhat short of this.

The other changes in muscle are of a kind which cannot be restricted to any exact period of the whole event, and as a rule are much more distinctly recognised as the result of tetanus than of a single spasm.

3. Physical changes other than electrical. During a contraction the temperature of the muscle rises. This may be ascertained with a thermopile and galvanometer; a delicate thermometer plunged into the midst of the muscles of the thigh of a frog, will also indicate a rise of temperature when these are tetanised. In a frog's muscle, the rise from a single contraction may, it is stated, reach $\cdot 005^{\circ}$ C.; in tetanus it may amount to $\cdot 15^{\circ}$ C.

The extensibility of the muscle is increased. Living muscle at rest is very extensible, and its elasticity is very perfect, *i.e.* after extension it returns almost exactly to its natural length.

When a muscle is extended by a series of weights increasing in magnitude, the curve (obtained by making the weights abscissæ and the extensions ordinates) is not a straight line, as is the case with dead elastic bodies, but a hyperbola.

If a muscle at rest be loaded with a given weight, say 50 grammes, and its extension observed, and be then while unloaded thrown into tetanus, and the load applied during the tetanus, the extension in the second case will be distinctly greater than in the first, indicating a marked *increase of extensibility during contraction*.

During tetanus a muscle gives out a sound, the muscular sound. This may be heard by applying the stethoscope to a muscle during contraction. It may be also heard by stopping the ears, and causing the masseter and temporal muscles to contract. When a muscle is thrown into tetanus by the will or by reflex action or by direct stimulation of the spinal cord, in fact, in any way through the action of the central nervous system, the same note is always heard, *viz.* one indicating 19·5 vibrations per second.

The note actually heard is one indicating 39 (36 to 40) vibrations per sec. This is, however, an harmonic of the primary note of the whole sound.

When a muscle is thrown into tetanus by interrupted shocks applied directly to the nerve or to the muscle, the note is the same as that of the interruptor determining the number of the shocks. This is naturally the case, since the note of the muscle-sound is determined by the rapidity of the spasms or vibrations which go to make up the tetanus, and these are determined by the rapidity with which the stimulus is repeated.

4. Chemical Changes. Acid is set free. A living muscle at rest is in reaction neutral, or, from some remains of lymph adhering to it, faintly alkaline. Tested by litmus paper it is frequently amphoteric, *i.e.* it will turn blue litmus red and red litmus blue,—but the change from red to blue is more marked than that from blue to red. If a muscle thus found neutral or alkaline be tetanized vigorously, and its reaction then tested, it will be found to be most distinctly acid. The red colouration of the blue litmus thus obtained is permanent, and cannot therefore be due to carbonic acid. It is probably due to sarcolactic acid¹.

Carbonic acid is set free in great excess. Blood in passing through a living muscle in the body, from being arterial becomes venous, *i.e.* the muscle takes up oxygen and gives out carbonic acid. This it does even when at rest; during contraction the quantity of carbonic acid is increased largely. There is also an increase in the assumption of oxygen, but not at all in the ratio of the carbonic acid given out. To this point we shall return in speaking of respiration. If a muscle, *ex. gr.* a frog's muscle, removed from the body, be suspended in an atmosphere of known composition containing oxygen, a steady consumption of oxygen and a steady production of carbonic acid continues to take place for some time. When the muscle is tetanized, a very large increase in the production of carbonic acid is observed, but none or a very slight one only in the consumption of oxygen. A frog's muscle will continue to live for a while and to contract vigorously in an atmosphere perfectly free from oxygen. Now a muscle contains in itself no free or loosely combined oxygen such as would serve for its own oxidation. When a frog's muscle is subjected to the action of a mercurial air-pump, no oxygen can be extracted from it. In this respect muscle differs markedly from blood, which, as we shall see in dealing with respiration, gives up a very considerable quantity of oxygen to a vacuum. Hence when a muscle, itself containing no free or available oxygen, contracts in an atmosphere also free from oxygen, it is evident that during the contraction no *direct* oxidation takes place. Nevertheless the production of carbonic acid as the result of contraction goes on all the same. From this it is clear that the carbonic acid which is produced during contraction, cannot come from the direct oxidation of any carbon compounds. It probably has its source in the splitting up of some complex bodies, and the great parallelism which is found between

¹ See p. 34.

the amount of carbonic acid and of sarcolactic acid formed suggests the idea that they have a common origin.

The other chemical changes in muscle have not been clearly made out.

Helmholtz shewed long ago that by continued contraction the substances in muscle which are soluble in water, *i.e.* the aqueous extractives, are diminished, while those which are soluble in alcohol are increased. In other words, during contraction some substance or substances soluble in water are converted into another or other substances insoluble in water but soluble in alcohol. Ranke¹ concluded from his observations that the proteids are slightly diminished, and that sugar and fats are produced; but the data for these conclusions are, at present at all events, insufficient. It has been suggested that the glycogen naturally present in muscle is during contraction converted into sugar. The failure to obtain any satisfactory evidence of the production of nitrogenous crystalline bodies as the result of contraction is of interest; for though urea is conspicuous by its absence from muscle both during rest and after contraction, some observers have thought that the kreatin in muscle is increased by contraction: this has not been definitely proved.

¹ Putting all these facts together, the following may be taken as a brief approximate history of what takes place in a muscle and nerve when the latter is subjected to a single induction-shock. At the instant of the induced current passing through the nerve, changes occur, of whose nature we know nothing certain except that they occasion a negative variation of the natural nerve-current. These changes propagate themselves along the nerve in both directions as a nervous impulse in the form of a wave, having a wave-length of about 18 mm., and a velocity (in frog's nerve) of about 28 m. per sec. Passing down the nerve-fibres to the muscle, flowing along the branching and narrowing tracts, the wave at last breaks on the end-plates of the fibres of the muscle. Here it is transmuted into a muscle-impulse, with a shorter steeper wave, and a markedly diminished velocity (about 3 m. per sec.). This muscle-impulse, of which we know hardly more than that it is marked by a negative variation in the muscle-current, travels from each end-plate in both directions to the end of the fibre. What there becomes of it we do not know, but it is immediately followed by the visible contraction-wave, travelling behind it at about the same rate, but with a vastly increased wave-length. The fibre, as the wave passes over it, swells and shortens, bringing its two ends together, its molecules during the change of form arranging themselves in such a way that the extensibility of the fibre is increased, while at the same time an explosive decomposition of material takes place, leading to a burst of carbonic and sarcolactic acids, and probably of other unknown things, with a considerable development of heat.

¹ *Tetanus*, 1865.

The nature of the changes through which an electric current is able to generate a nervous impulse.

Action of the Constant Current. There now comes before us the question, In what way is an induction-shock, single or repeated, thus able to generate a nervous impulse or impulses? In an induction-shock we have a galvanic current of short duration, possessing certain characters of its own. What happens when a *constant* galvanic current is sent into a nerve *direct* from the battery? On examination the results, as far as muscular contraction is concerned, are found to vary considerably according to circumstances. Thus a contraction, a single spasm, may be witnessed when the current is made (thrown into the nerve), or when it is broken (taken away from the nerve), or at both events. Under certain conditions of the nerve and muscle a strong constant current may produce at making or breaking, not a simple spasm, but a prolonged and pronounced tetanus. This when it occurs is spoken of as the 'making tetanus' or 'breaking tetanus.' These however are exceptional; and as a general rule it may be stated, while the current is passing, provided that its intensity remains uniform, no contraction is produced. It requires either a sudden increase or a sudden decrease in the intensity (make and break being themselves a maximum increase and decrease), in order to generate a nervous impulse, and so to produce a contraction.

Electrotonus. Nevertheless, even in the absence of all contractions, the nerve, both between and beyond the electrodes, is, during the passage of the constant current, in a peculiar condition known as 'electrotonus.' The marked features of the electrotonic condition is that the nerve though apparently quiescent is changed in respect to its irritability; and that in a different way in the neighbourhood of the two electrodes respectively. Suppose that on the nerve of a muscle-nerve preparation are placed two (non-polarisable) electrodes (Fig. 12, *a*, *k*) connected with a battery and arranged with a key so that a constant current can at pleasure be thrown into or shut off from the nerve. This constant current, whose effects we are about to study, may be called the 'polarizing current.'

Let *a* be the positive electrode or anode, and *k* the negative electrode or kathode, both placed at some distance from the muscle, and also with a certain interval between each other. At the point *x* let there be applied a pair of electrodes connected with an induction-machine. Let the muscle further be connected with a lever, so that its contractions can be recorded, and their amount measured. Before the polarizing current is thrown into the nerve, let a single induction-shock of known intensity (a weak one being chosen, or at least not one which would cause in the muscle a maximum contraction) be thrown in at *x*. A contraction of a certain amount will follow. That contraction may be taken as a measure of the irritability of the nerve

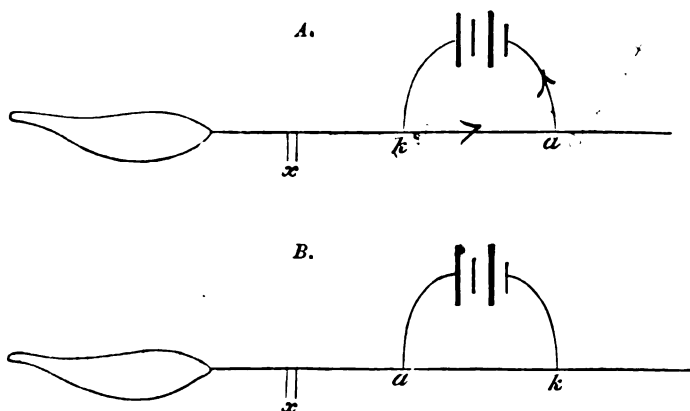

FIG. 12. MUSCLE-NERVE PREPARATIONS, with the nerve exposed in *A* to a *descending* and in *B* to an *ascending* constant current.

In each *a* is the anode, *k* the kathode of the constant current. *x* represents the spot where the induction-shocks used to test the irritability of the nerve are sent in.

at the point *x*. Now let the polarizing current be thrown in, and let the direction of the current be a *descending* one, with the kathode or negative pole nearest the muscle, as in Fig. 12 *A*. If while the current is passing, the same induction-shock as before be sent through *x*, the contraction which results will be found to be greater than on the former occasion. If the polarizing current be shut off, and the point *x* after a short interval again tested with the same induction-shock, the contraction will be no longer greater, but of the same amount, or perhaps not so great, as at first. During the passage of the polarizing current, therefore, the irritability of the nerve at the point *x* has been temporarily *increased*, since the same shock applied to it causes a greater contraction in the muscle than in the absence of the current. But this is only true so long as the polarizing current is a *descending* one, so long as the point *x* lies on the side of the kathode. On the other hand, if the polarizing current had been an *ascending* one, with the anode or positive pole nearest the muscle, as in Fig. 12 *B*, the irritability of the nerve at *x* would have been found to be *diminished* instead of increased by the polarizing current. That is to say, that when a constant current is applied to a nerve, the irritability of the nerve between the polarizing electrodes and the muscle is increased when the kathode is nearest the muscle (and the polarizing current *descending*) and diminished when the anode is nearest the muscle (and the polarizing current *ascending*) during the passage of the current. The same result, *mutatis mutandis*, and with some qualifications to be referred to directly, would be gained if *x* were placed not between the muscle and the polarizing current, but on the far side of the latter. Hence it may be stated generally that during the passage

of a constant current through a nerve the irritability of the nerve is increased in the region of the kathode, and diminished in the region of the anode. The changes in the nerve which give rise to this increase of irritability in the region of the kathode are spoken of as *katelectrotonus*, and the nerve is said to be in a katelectrotonic condition. Similarly the changes in the region of the anode are spoken of as *anelectrotonus*, and the nerve is said to be in an anelectrotonic condition. It is also often usual to speak of the katelectrotonic increase, and anelectrotonic decrease of irritability.

This law remains true whatever be the mode adopted for determining the irritability. The result holds good not only with a single induction-shock, but also with a tetanizing interrupted current, with chemical and with mechanical stimuli. The increase and decrease of irritability are most marked in the immediate neighbourhood of the electrodes, but spread for a considerable distance in either direction in the extrapolar regions. The same modification is not confined to the extrapolar region, but exists also in the intrapolar region. In the intrapolar region there must be of course an indifferent point, where the katelectrotonic increase merges into the anelectrotonic decrease, and where therefore the irritability is unchanged. When the polarizing current is a weak one, this indifferent point is nearer the anode than the kathode, but as the polarizing current increases in intensity, draws nearer and nearer the kathode (see Fig. 13).

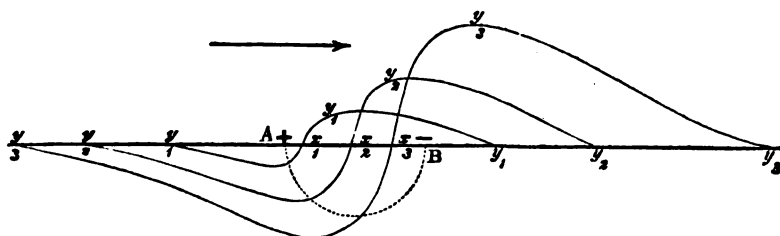

FIG. 13. DIAGRAM ILLUSTRATING THE VARIATIONS OF IRRITABILITY DURING ELECTROTONUS, WITH POLARIZING CURRENTS OF INCREASING INTENSITY (from Pfüger).

The anode is supposed to be placed at A, the kathode at B; AB is consequently the intrapolar district. In each of the three curves, the portion of the curve below the base line represents diminished irritability, that above, increased irritability. y_1 represents the effect of a weak current; the indifferent point x_1 is near the anode A. In y_2 , a stronger current, the indifferent point x_2 is nearer the kathode B, the diminution of irritability in anelectrotonus and the increase in katelectrotonus being greater than in y_1 ; the effect also spreads for a greater distance along the extrapolar regions in both directions. In y_3 the same events are seen to be still more marked.

The katelectrotonic increase and anelectrotonic decrease reach a maximum soon after the making of the polarizing current, and thenceforward gradually diminish. The two effects however are not quite parallel. The katelectrotonic increase is the first to be developed; it rapidly rises to a maximum and somewhat rapidly

declines. The anelectrotonic decrease is not manifest at first; when it does appear it increases slowly, and having reached a maximum diminishes slowly again.

When the polarizing current is shut off there is a rebound at either pole; a temporary increase of irritability in the anelectrotonic and a temporary decrease in the katelectrotonic regions.

The amount of increase and decrease is dependent: (1) On the strength of the current, the stronger current up to a certain limit producing the greater effect. (2) On the irritability of the nerve, the more irritable, better conditioned nerve being the more affected by a current of the same intensity.

The increase or decrease of irritability applies not only to the origination of impulses, but also to their propagation or conduction. At least anelectrotonus offers an obstacle to the passage of a nervous impulse.

These variations of irritability at the kathode and anode respectively must be the result of molecular changes, brought about by the action of the constant current. We are not at present able to say what those molecular changes are, but we have evidence of *physical* phenomena accompanying and probably connected with the *physiological* phenomena just described.

During the passage of a constant current through a nerve, variations in the electric currents of the nerve analogous in many respects to the variations of the irritability of the nerve may be witnessed. Thus if a constant current supplied by the battery *P* (Fig. 14) be applied to a piece of nerve by means of two non-polarisable electrodes *p*, *p'*, the currents obtainable from various points of the nerve will be different during the passage of the polarizing current from those which were manifest before or after the current was applied; and, moreover, the changes in the nerve-currents produced by the polarizing current will not be the same in the neighbourhood of the anode (*p*) as those in the neighbourhood of the kathode (*p'*). Thus let *G* and *H* be two galvanometers so connected with the two ends of the nerve as to obtain good and clear evidence of the natural nerve-currents. Before the polarizing current is thrown into the nerve, the needle of *H* will occupy a position indicating the passage of a current of a certain intensity from *h* to *h'* through the galvanometer (from the positive longitudinal surface to the negative cut end of the nerve), the circuit being completed by a current in the nerve from *h'* to *h*, i.e. the current will flow in the direction of the arrow. Similarly the needle of *G* will by its deflection indicate the existence of a current flowing from *g* to *g'* through the galvanometer, and from *g'* to *g* through the nerve, in the direction of the arrow.

At the instant that the polarizing current is thrown into the nerve at *pp'*, the currents at *gg'*, *hh'* will suffer a negative variation corresponding to the nervous impulse, which, at the making of the polarizing current, passes in both directions along the nerve, and may

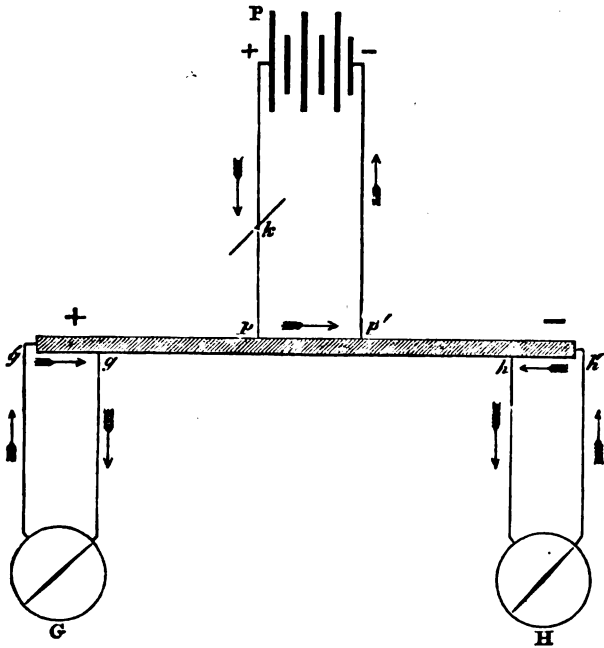

FIG. 14. DIAGRAM ILLUSTRATING ELECTROTONUS.

P the polarizing battery, with *k* a key, *p* the anode, and *p'* the kathode. At the left end of the piece of nerve the natural current flows through the galvanometer *G* from *g* to *g'*, in the direction of the arrows; its direction therefore is the same as that of the polarizing current; consequently it appears increased as indicated by the sign +. The current at the other end of the piece of nerve, from *h* to *h'*, through the galvanometer *H*, flows in a contrary direction to the polarizing current; it consequently appears to be diminished, as indicated by the sign -.

N.B. For simplicity's sake, the polarizing current is here supposed to be thrown in at the middle of a piece of nerve, and the galvanometer placed at the two ends. Of course it will be understood that the former may be thrown in anywhere, and the latter connected with any two pairs of points which will give currents.

cause a contraction in the attached muscle. The negative variation is, as we have seen (p. 54), of extremely short duration, it is over and gone in a small fraction of a second. It therefore has nothing to do with a permanent effect which, in the case we are dealing with, is observed in both galvanometers. This effect, which is dependent on the direction of the polarizing current, is as follows: Supposing that the polarizing current is flowing in the direction of the arrow in the figure, and therefore passing in the nerve from the positive electrode or anode *p* to the negative electrode or kathode *p'*, it is found that the current through the galvanometer *G* is increased, while that through *H* is diminished. We may explain this result by saying that the polarizing current has developed in the nerve outside the electrodes a new current, the 'electrotonic' current, having the

same direction as itself, which adds to, or takes away from, the natural nerve-current, according as it is flowing in the same direction or in an opposite one.

The strength of the electrotonic current is dependent on the strength of the polarizing current, on the length of the intrapolar region which is exposed to the polarizing current, and on the irritability or vital condition of the nerve. A dead nerve will not manifest an electrotonic current, and the propagation of the electrotonic current is stopped by a ligature; the current is therefore a vital not a mere physical phenomenon, and the effects produced on the galvanometer are certainly not in any way due to a mere escape of the polarizing current along the nerve.

The application of the constant current then throws a nerve, during its passage, into a peculiar condition characterized by the appearance of a new (electrotonic) current. This we may speak of as a *physical* electrotonus analogous to that *physiological* electrotonus which is made known by variations in irritability. And the general laws of the one are so parallel to those of the other that it seems difficult not to suppose that they are fundamentally connected. In the example given above, which was chosen for its simplicity, the electrotonic current *diminishes* the effect of the natural nerve-current in the neighbourhood of the kathode, where, as we have seen, irritability is increased, and *increases* the effect of the natural nerve-current in the neighbourhood of the anode, where, as we have seen, irritability is diminished. But an electrotonic current may make its appearance when the electrodes of the galvanometer are so disposed that no natural current is indicated, and therefore we cannot speak of the natural current being either increased or diminished. Moreover, the electrodes of the galvanometer may be so placed in reference to the polarizing current (as for instance when the polarizing current is brought to bear entirely on one side of the equator of a piece of nerve) that the natural current may appear to be increased at the kathode, and diminished at the anode. It is best in fact to consider the electrotonic current as distinct from the natural current. And since there are differences observable between the effects at the kathode and those at the anode, irrespective of the natural currents, we may complete the analogy of the physical with the physiological electrotonus by speaking of a katelectrotonic current and an anelectrotonic current.

The katelectrotonic current, like the katelectrotonic increase of irritability, rises very rapidly (almost immediately) to a maximum and then speedily declines. The anelectrotonic current, like the anelectrotonic decrease of irritability, rises slowly to a maximum and slowly declines. And generally the katelectrotonic current is less than the anelectrotonic.

The electromotive force of the electrotonic current may be much greater than that of the natural nerve-current, so that when the latter is opposed in direction to the former, the needle of the galvanometer may be carried a considerable distance beyond zero. There are difficulties in the

way of estimating the force exactly, but Du Bois-Reymond¹ gives as an instance an electromotive force of .5 Daniell for the anelectrotonic and .05 Daniell for the katelectrotonic current.

There are practical difficulties in the way of demonstrating the existence of an electrotonic current, in the intrapolar regions between the polarizing electrodes; and some observers maintain that it is in reality absent from this region, and confined entirely to the extrapolar districts. It spreads, with a diminution in intensity, for some distance along the extrapolar districts in both directions.

When the polarizing current is broken there is a rebound in the opposite direction, the natural current previously diminished or increased being for a brief period increased or diminished. According to Hermann there is no such rebound at the kathode in the extrapolar region, the current developed on breaking having here the same direction as previously.

Though the appearance of the negative variation of the natural current is so marked a feature of a muscular contraction, no electrotonic currents whatever can be discovered in a muscle when a constant current is applied to it.

This presents a difficulty, from which however we may escape by supposing that both in a muscle and in a nerve electrotonic currents, though not demonstrable, are originated in the intrapolar region, but that in a muscle, unlike the case of a nerve, certain obstacles exist which prevent the propagation of the electrotonic current from the intrapolar region, (where they cannot be shewn) to the extrapolar regions (where if present they might easily be detected).

Law of Contraction. At the making of a constant current, then, there is set up a condition of katelectrotonus and of anelectrotonus; on the breaking of the current these conditions with more or less rebound disappear. What have these changes to do with the generation of nervous impulses?

It has already been stated that when a constant current is applied to a nerve, a contraction is caused in the muscle, *i. e.* a nervous impulse is started in the nerve, either at the make or at the break, or at both. On further examination it is found that the occurrence or non-occurrence of a contraction depends on the direction (*i. e.* whether descending with the kathode nearest the muscle, Fig. 12 A, or ascending with the anode nearest the muscle, Fig. 12 B) and intensity of the current. The results have been formulated in the following 'law of contraction.'

	Descending.		Ascending.	
	Make	Break	Make	Break
Very Weak	C	—	—	—
Weak	C	—	C	—
Mod.	C	C	C	C
Strong	C	—	—	C

where C indicates a contraction. This law becomes intelligible if we suppose that nervous impulses are originated only by the rise of

¹ *Gesaml. Abhandl.* II. 260.

katelectrotonus and by the fall of anelectrotonus, and not at all by the rise of anelectrotonus, or by the fall of katelectrotonus, or by the steady maintenance of either. Remembering that in katelectrotonus irritability is increased and in anelectrotonus diminished, we may formulate the law as follows: a nervous impulse is generated at any point of a nerve when there is a sudden change from a phase of lower to one of higher irritability, as from the normal condition to katelectrotonus or from anelectrotonus to the normal condition. We must however further suppose that the rise of katelectrotonus more readily gives rise to an impulse, or gives rise to a larger impulse, than does the fall of anelectrotonus, and that the condition of anelectrotonus, especially when pronounced, is an obstacle to the passage towards the muscle of impulses originating on the side away from the muscle. Thus with weak currents, a contraction occurs only at the make, at the rise of katelectrotonus, of both the descending and ascending currents. But the contraction is easier to get with the descending than with the ascending current, because in the latter the impulse started at the kathode has to pass through an anelectrotonic region before it can arrive at the muscle. With a moderate current, as for instance with a single Daniell acting as the source of the current, there is a contraction both at the make and at the break of both ascending and descending currents; the fall of anelectrotonus here is able, as well as the rise of katelectrotonus, to originate a nervous impulse. Lastly, when the current is very strong, as that for instance of two or more Groves, making the ascending current produces no contraction, because the anelectrotonus round the anode blocks the impulse starting from the kathode. The fall of anelectrotonus however at the anode, there being nothing between it and the muscle, does cause a contraction. With the descending current the rise of katelectrotonus produces a making contraction, but there is no breaking contraction; the absence of the latter may be accounted for, partly by the strong current depressing the irritability, and especially the conductivity of the intrapolar nerve, and partly perhaps by supposing that the disappearance of katelectrotonus at the kathode, occurring as it does in a part lying between the anode and the muscle, serves to block the downward progress of the impulse started by the fall of anelectrotonus at the anode.

This blocking of nervous impulses by the defective conduction caused in anelectrotonus, is the reason why in testing the variations of irritability in anelectrotonus and katelectrotonus it is preferable to apply the stimulus between the muscle and the polarizing current.

It has already been stated that in many cases the making or breaking of a constant current gives rise not to a single spasm only but to a pronounced tetanus, often spoken of as the making or breaking tetanus. Of these two the most common is the breaking tetanus, or Ritter's tetanus, which appears when a strong current has been applied for some time to a nerve. It is developed most readily and lasts longest after the application

of an ascending current, but may also make its appearance with a descending current. When it manifests itself it may be at once diminished or suspended altogether by applying the same current in the same direction. It is increased by applying the current in an opposite direction. The making tetanus is seen with currents of a certain intensity only, being absent with those of less or greater strength. Both forms are due to profound electrolytic changes in the nerve, those of the making tetanus being of a katelectrotonic, and those of the breaking tetanus of an anelectrotonic character.

We can now understand why a single inductive-shock produces a single spasm; for a single induction-shock is the application of a current of exceedingly short duration, in which the break is separated from the make by so very small an interval, that one only contraction has time to be developed. This may be the result of a rise of katelectrotonus alone, or of that and of the fall of anelectrotonus fused into one. Moreover, the induced current is developed very rapidly and disappears slowly. Hence it is more potent as a stimulus in its appearance than in its disappearance; and in the case of weak currents the disappearance may be disregarded as far as stimulation is concerned, so that the effect of the induced current may be looked upon as equivalent to that resulting from the making of a constant current, *i.e.* a rise of katelectrotonus only. This is true of the induced current produced either by the making or by the breaking of a constant current.

The constant current applied directly to a muscle from which the purely nervous element has been eliminated by urari poisoning, has effects similar to and yet somewhat different from those which it has upon a nerve. The absence of electrotonic currents has already been referred to. The respective efficacy of the rise of katelectrotonus and the fall of anelectrotonus in producing contraction are the same as in a nerve. In one respect the muscle is more striking and offers a support of the hypothesis mentioned above. The making contraction may under favourable circumstances be seen to start from the kathode and the breaking contraction from the anode. Another marked difference between muscle and nerve is that in muscle the current must act for some appreciable time upon the tissue before it can call forth a contraction. This is what we might expect from the more sluggish nature of the muscular impulse-wave. Hence muscular tissue which has lost its nervous elements or does not possess them, is far less readily affected by the rapid induction-shocks than are nerves.

During the passage of a constant current the muscle is thrown into a partial tetanus, which however may be sufficiently weak to permit the simple make and break contractions to be readily observed¹. Very frequently this tetanus changes into a regular rhythmic pulsation if the intramuscular nerves be intact.

¹ Romanes, *Journal of Anat. and Phys.* x. p. 707.

Circumstances affecting the amount and character of the contraction.

1. **Nature of the stimulus.** A mechanical stimulus in the shape of a single tap or blow, pinch or prick, may produce a single spasm, and slight taps repeated regularly and rapidly may be used to produce a tetanus. As a rule, however, the injury inflicted by a mechanical stimulus destroys the irritability of the spot stimulated, and so prevents a repetition of the spasms. Violent and extensive injury may produce tetanus. A chemical stimulus produces an irregular tetanus, as does also the sudden application of heat. A galvanic current acts, as we have seen, as a stimulus when there is a sudden rise or fall in the intensity of the current, making and breaking being extreme cases of rise and fall. If the rise and fall be sufficiently gradual, a current may, while still passing through a nerve, be increased or diminished very largely without any contraction taking place; whereas a very slight, sudden rise or fall at once gives rise to one: the more sudden the change, the greater the effect. Thus in single induction-shocks, the breaking shock, which is developed much more rapidly than the making shock, is by far the more potent of the two. Of the nature of the action of organic or vital stimuli we know very little.

2. **Application of a galvanic current.** In order that a galvanic current of any kind may call forth a contraction, some appreciable length of nerve must be placed between the electrodes. If the current simply be sent transversely through a nerve, little or no contraction takes place. With the same strength of current, the longer the piece of nerve, the greater the contraction.

This is said to be true of the descending but not of the ascending constant current, and the results are more constant with the making than the breaking of the current¹.

In the case of a single application of a current, there must be a certain duration of the application, varying with the strength of the current; otherwise, no impulse or contraction will be generated. It is said that a current, of whatever strength, must last at least .0015 sec. in order to produce a contraction². And in general the less the duration of the stimulus the slighter is the effect. Hence stimuli which produce a contraction when applied for a given, though still short, time may fail to give rise to one when applied for a still shorter time, the stronger stimuli naturally needing the shorter duration of application in order to produce their effects.

Hence also a stimulus of moderate strength, which when applied singly is able to call forth a contraction, may, when repeated rapidly, by means of a rotation machine, instead of producing tetanus, give rise to no visible effect at all. In this case the absence of effect is probably due to the mechanism of repetition shortening the duration of each individual shock. But over and above this, the mere repetition has an effect of its own. Thus Helmholtz

¹ Willy, Pflüger's *Archiv*, v. (1872) 275.

² König, *Wien. Sitzungs-Bericht*, LXII.

holtz¹ has shewn that when an induction-shock giving a maximum contraction is followed at an interval of less than $\frac{1}{800}$ sec. by a second shock of equal strength, no second contraction appears at all. During $\frac{1}{800}$ sec. subsequent to the first shock the muscle is absolutely devoid of irritability; it is in a "refractory phase" similar to but much shorter than that which is so conspicuous in cardiac muscles. Hence if a number of maximum induction-shocks be sent into a muscle or nerve at intervals of a little less than $\frac{1}{800}$ th sec. half the shocks sent in would seem to be without effect. Bernstein² finds that when induction-shocks are repeated sufficiently rapidly, tetanus is absent; there is an initial contraction with the first shock and after that complete rest. The rapidity necessary to produce this result varies with the strength of the shocks employed. The interpretation of the results however is not at present clear; and Kronecker, making use of a vibrating rod as an interruptor, finds that tetanus still appears, though the rapidity of the interruptions be carried far beyond Bernstein's limit.

3. The strength of the current. If the nerve of a muscle-nerve preparation be stimulated at intervals by currents of increasing intensity, beginning with those having no effect at all, it is found that the effect, as measured by the height of the contraction, rises very rapidly to a maximum, and then remains constant.

4. The load. It might be imagined that a muscle, which, when loaded with a given weight, say 20 grammes, and stimulated by a current of a given intensity, had contracted to a certain extent, would only contract to half that extent when loaded with twice the weight (40 grammes) and stimulated with the same stimulus. Such, however, is not the case; the height to which the weight is raised may be as great, or even greater, in the second instance, than in the first. That is to say, the resistance offered to the contraction actually increases the contraction, the tension of the muscular fibre increases the facility with which the explosive changes resulting in a contraction take place. And it has been observed by Heidenhain³ that tension applied to a muscle increases both the chemical products (carbonic and lactic acid) and the rise of temperature which accompany a contraction. There is, of course, a limit to this favourable action of the resistance. As the load continues to be increased, the height of the contraction is diminished, and at last a point is reached at which the muscle is unable (even when the stimulus chosen is the strongest possible) to lift the load at all.

It is said that a muscle, loaded beyond its power, relaxes and lengthens when stimulated instead of shortening, in consequence of that increase of extensibility which is a characteristic of the contracted state. The occurrence of this lengthening is however doubtful.

It is obvious that the work done (height to which the load is raised multiplied into the weight of the load) must therefore

¹ Berlin. Monatsbericht, 1854.

² Op. cit.

³ *Mechanische Leistung, Wärmeentwicklung und Stoffumsatz bei der Muskelthätigkeit.* Leipzig, 1864.

be largely dependent on the weight itself. Thus there is a certain weight of load with which in any given muscle, stimulated by a given stimulus, the most work will be done.

Since mere tension affects the changes going on in the muscular fibres, it is desirable in experiments in which muscles are loaded, that the weight should not bear upon the lever until the contraction actually begins. This is easily managed by interposing between the end of the muscle and the weight a lever with a support so arranged that, before contraction takes place, the weight only extends the muscle to the length natural to it during rest; but that the muscle directly it shortens at once begins to pull on the weight. The muscle is then said to be *after-loaded*¹.

If the weight be determined which will stop a contraction when applied directly the contraction begins, and also that which stops a contraction when applied at a moment when the contraction is already partly accomplished, it will be found that the second weight is much less than the first. It will be found, in fact, that the force of a contraction is at its maximum at the beginning of the shortening, and thenceforwards declines until it becomes nothing when the shortening is complete.

5. Size and Form of the Muscle. Since all known muscular fibres are much shorter than the wave-length of a contraction, it is obvious that the longer the fibre, the greater the height of the contraction with the same stimulus. Hence in a muscle of parallel fibres, the height to which the load is raised as the result of a given stimulus applied to its nerve, will depend on the length of the fibres, while the weight of the load so lifted will depend on the number of the fibres, since the load is distributed among them. Of two muscles therefore of equal length (and of the same quality) the most work will be done by that which has the greater sectional area; and of two muscles with equal sectional areas, the most work will be done by that which is the longer. If the two muscles are unequal both in length and sectional area, the work done will be the greater in the one which has the larger bulk, which contains the greater number of cubic units. In speaking therefore of the maximum of work which can be done by a muscle, we may use as a standard a cubic unit of bulk, or, the specific gravity of the muscle being the same, a unit of weight. In the case of frog's muscle, the maximum of work which can be done under most favourable circumstances has been estimated by Fick² to vary between 3 and 7 ~~kilo~~grammeters for 1 grm. of muscle.

The weight which is just sufficient, but only just sufficient, to keep a muscle, when stimulated, from actually shortening, may be taken as the measure of the 'absolute power' of the muscle. It must of course be taken only in relation to the sectional area of the

¹ This is perhaps the best equivalent of the German *überlastet*.

² *Untersuch. ü. Muskelarbeit*, Basel, 1867.

muscle. The absolute power of a square centimetre of frog's muscle has been in this way estimated at about 2800 to 3000 grms.: of a square centimetre of human muscle at 6000 to 8000 grms.

6. Condition of the Nerve. When two pairs of electrodes are placed on the nerve of a long and a perfectly fresh and successful nerve-preparation, one near to the cut end, and the other nearer the muscle, it is found that the same stimulus produces a greater contraction when applied through the former pair of electrodes than through the latter. Two interpretations of this result are possible. Either the nerve at the part farther away from the muscle is more irritable, *i.e.* that the stimulus gives rise *at the spot stimulated* to a larger nervous impulse; or the impulse started at the farther electrodes gathers strength, like an avalanche, in its progress to the muscle. The latter view has been strongly urged by Pflüger, and is generally known under the name of the 'avalanche theory.' As far as we know, however, the progress of the negative variation along a nerve is marked by no such increase; Du Bois-Reymond found that the amount of the negative variation, if it changed at all, was slightly diminished at a distance from the spot stimulated. It is probable that the larger contraction produced by stimulation of the portions of the nerve near the spinal cord is due to the stimulus setting free a larger impulse, *i.e.* to this part of the nerve being more irritable.

The effect is not due to the section merely, for it may be witnessed in nerves still in connection with the spinal cord. Heidenhain¹ states however that under these circumstances the diminution of the effect is not gradual from the central to the peripheral portions, as when the nerve is cut; on the contrary, the amount of contraction is at first large, then becomes smaller, and finally increases somewhat again as the stimulation is carried from the roots of the nerves to the muscular periphery.

It is probable that the irritability of the nerve may vary considerably at different points along its course. And Fleischl² states that the behaviour of a nerve to induction-shocks differs at different parts of its course according as the induced shock is applied as a descending or an ascending current.

In addition to this, however, section of a nerve does of itself lead to a temporary increase in the neighbourhood of the section. But after a while this increased irritability gives place to a decreased irritability near the cut end, as compared with the more peripheral portions; exhaustion, as it is said, sets in in this part, and spreads gradually downwards towards the muscle. When a nerve is simply divided *in situ*, in the living body, very similar phenomena are observed. At first there is an increase of irritability, observable especially at the cut end, and travelling centrifugally towards the periphery. Subsequently the irritability diminishes, and gradually disappears, the loss beginning at the cut end and advancing centrifugally

¹ *Stud. Physiol. Institut. Breslau*, II. (1861).

² *Wien. Sitz.-Bericht*, LXXII. Compare Tiegel. *Pflüger's Archiv*, XIII. (1876) p. 598.

towards the peripheral terminations. This centrifugal feature of the loss of irritability is often spoken of as the Ritter-Valli law. The exhaustion thus produced is followed, in a similar centrifugal manner, by structural degeneration of the nerve. In a mammal it may be two or three days, in a frog, as many, or even more weeks before irritability has disappeared from the trunks. It is maintained in the small (and especially in the intramuscular) branches for still longer periods.

Exhaustion of a nerve, in whatever way produced, whether by poison, or by withdrawal of blood, or by section, or by other means, is marked by gradual loss of irritability, *i.e.* the stimulus required to produce a contraction in the muscle must be gradually increased, until at last the strongest stimuli are ineffective. In some cases at least, exhaustion has been ascertained to be accompanied by a retardation of the impulse-wave. Beyond this we know little. The irritability of both muscles and nerves is ultimately dependent on the state of their nutrition, and this again is determined in the first place by the quality and quantity of the blood supplied to the tissue, and in the second place by the functional activity of the tissue, *i.e.* by the extent to which its specific energies are called into play.

The effects of varying the blood-supply and functional activity can be much more easily studied, and consequently are much better known, in the case of muscles than of nerves, but there is no reason to doubt that the same general laws govern the life of both tissues.

7. Condition of the Muscle. Exhaustion. When a muscle of a warm- or of a cold-blooded animal is removed from the body, the irritability gradually diminishes. The same stimulus repeated at intervals gives rise to smaller and smaller contractions. At last the irritability disappears altogether, and no stimulus however strong produces any contraction at all. In the muscle of a warm-blooded animal the descent is very rapid, occupying a time which varies, according to circumstances, from a few minutes to two or three hours. In the muscle of a cold-blooded animal the irritability may continue for as long as two or three days. Otherwise the progress of events is the same in each.

If a sharp blow with some thin body be struck across a muscle which has entered into the later stages of exhaustion, a wheal lasting for several seconds is developed. The wheal in many respects resembles a very slow or almost fixed contraction-wave, and has been called an 'idio-muscular' contraction, because it may be brought out even when ordinary stimuli have ceased to produce any effect. It may however be accompanied at its beginning by an ordinary contraction. It is readily produced in the living body on the pectoral and other muscles of persons suffering from phthisis and other exhausting diseases.

Rigor Mortis. The loss of irritability, even when rapid, is gradual, but is succeeded by an event of some suddenness, the entrance into the condition known as rigor mortis, the occurrence of

which is marked by the following features. The muscle, previously possessing a certain transparency, becomes much more opaque. Previously very extensible and elastic, it becomes rigid and inextensible and at the same time loses its elasticity. The muscle now requires considerable force to stretch it, and when the force is removed, does not, as before, return to its natural length. To the touch it has lost much of its former softness, and becomes firmer and more resistant. The entrance into rigor mortis is characterised by a shortening or contraction, which may, under certain circumstances, be considerable. The energy of this contraction is not great, so that when opposed, no actual shortening is observed. When rigor mortis has been fully developed, no muscle-currents whatever are observed. Tested by litmus paper the muscle is found to have become distinctly acid. The amount of acidity is very considerable, much greater than that of even a prolonged tetanus. It is, apparently, due to the presence of the same acid as that produced in a contraction. If a muscle be suspended in a known atmosphere it is found that the comparatively feeble production of carbonic acid, which goes on as long as the muscle is irritable, undergoes a very large increase when rigor mortis sets in. As rigor mortis comes on, the muscle undergoes a distinct rise of temperature which is coincident in time with the shortening. In many respects, therefore, rigor mortis has a strong resemblance to an ordinary contraction. In one point the two differ fundamentally. In a contraction the extensibility is increased, in rigor mortis it is diminished. But in other respects, in the shortening, the rise of temperature, the diminution (in the case of rigor mortis to disappearance) of natural muscle-currents, and the production of sarcolactic and carbonic acids, the two seem identical. They both seem to be due to an explosive decomposition within the fibre. The peculiar features of rigor mortis appear to be in part at least due to the fact that the decomposition is in that case accompanied by, or results in, a coagulation of some portion of the fibre. From the perfectly fresh, as yet irritable muscles of a frog, a coagulable muscle-plasma may by appropriate means be obtained, see *antea*, p. 33. If rigid muscles be treated in the same way no such coagulable plasma will be obtained. It has already been seen that the rigid fibres consist largely of myosin. Thus while from the irritable or not yet rigid muscle there can be extracted a coagulable plasma, which on coagulating gives rise to myosin, from the rigid muscle there can only be extracted the already formed myosin, which therefore may be regarded as the result of a coagulation coincident with, and constituting an important part of the phenomena of, rigor mortis.

It is stated by Hermann that in frog's muscle separated from the body, the quantity of carbonic acid given out during rigor mortis is in inverse proportion to the quantity given out by the contractions which have taken place since the removal of the muscle from the blood-current. The more the muscle has contracted during this period the less the amount of carbonic acid given out in the final rigor, and *vice versa*. From this it is inferred

that at the moment of separation from the body, the muscle contains a certain capital of carbonic-acid-producing material (to wit, the substance whose explosive decomposition we have supposed to give rise to this and other bodies) which may be expended either in rigor mortis or in contraction, but which, from the absence of blood, cannot be replaced. Consequently the expenditure in the direction of contraction must come out of the share allotted to rigor mortis. To this point we shall return.

The Influence of Blood-supply. When a muscle still within the body is deprived by any means of its proper blood-supply, as when the blood-vessels going to it are ligatured, the same gradual loss of irritability and final appearance of rigor mortis are observed as in muscles removed out of the body. Thus if the abdominal aorta be ligatured, the muscles of the lower limbs lose their irritability and finally become rigid. So also in systemic death, when the blood-supply to the muscles is cut off by the cessation of the circulation, loss of irritability ensues, and rigor mortis eventually follows. In a human corpse the muscles of the body enter into rigor mortis in a fixed order: first those of the jaw and neck, then those of the trunk, next those of the arms, and lastly those of the legs. The rapidity with which rigor mortis comes on after death varies considerably, being determined both by external circumstances and by the internal conditions of the body. Thus external warmth hastens and cold retards the onset. After great muscular exertion, as in hunted animals, and when death closes wasting diseases, rigor mortis in most cases comes on rapidly. As a general rule it may be said that the later it is in making its appearance, the more pronounced it is, and the longer it lasts; but there are many exceptions, and when the state is recognised as being fundamentally due to a coagulation, it is easy to understand that the amount of rigidity, *i.e.* the amount of the coagulum and the rapidity of the onset, *i.e.* the quickness with which coagulation takes place, may vary independently. The rapidity of onset after muscular exercise and wasting disease is apparently dependent on an excess of acid produced under those circumstances in the muscle. When rigor mortis has once become thoroughly established in a muscle through deprivation of blood, it cannot be removed by any subsequent supply of blood. Thus where the abdominal aorta has remained ligatured until the lower limbs have become completely rigid, untying the ligature will not restore the muscles to an irritable condition; it simply hastens their decomposition.

A muscle however may acquire as a whole a certain amount of rigidity on account of some of the fibres becoming rigid, while the remainder, though they have lost their irritability, have not yet advanced into rigor mortis. At such a juncture a renewal of the blood-stream may restore the irritability of those fibres which were not yet rigid, and thus appear to do away with rigor mortis; yet it appears that in such cases the fibres which have actually become rigid never regain their irritability, but undergo

degeneration. It is stated however by Preyer¹ that if the even completely rigid muscles of the frog be washed out with a 10 p. c. sodium chloride solution (which dissolves myosin) and subsequently injected with blood, irritability will be restored.

Mere loss of irritability, even though complete, if stopping short of the actual coagulation of the muscle-substance, may be with care removed. Thus if a stream of blood be sent artificially through the vessels of a separated (mammalian) muscle, the irritability may be maintained for a very considerable time. On stopping the artificial circulation, the irritability diminishes and in time entirely disappears; if however the stream be at once resumed, the irritability will be recovered, and maintained. By regulating the flow, the irritability may be lowered and (up to a certain limit) raised at pleasure. From the epoch however of interference with the normal blood-stream there is a gradual diminution in the responses to stimuli, and ultimately the muscle loses all its irritability and becomes rigid, however well the artificial circulation be kept up. This failure may be due simply to the fact that an artificial circulation is at best an imperfect circulation, or it may be due to other (as yet unknown) causes.

The irritability of a muscle then is clearly in large measure dependent on the *quantity* of blood supplied to it. In respect to the *quality* of blood, our knowledge is definite with regard to one factor only, viz. the oxygen. If blood deprived of its oxygen be sent through a muscle removed from the body, irritability, so far from being maintained, seems rather to have its disappearance hastened. In fact, if venous blood continue to be driven through the muscle the irritability is lost even more rapidly than in the entire absence of blood. It would seem that venous blood is more injurious than none at all. If exhaustion be not carried too far, the muscle may, however, be revived by a proper supply of oxygenated blood.

In a muscle the irritability of which has been suspended by a current of venous blood, the assumption of a minute fraction of oxygen is sufficient to restore irritability to such an extent that a very distinct amount of contraction is visible on the application of stimuli. Much more than this must be taken up before the muscle can regain the standard at which it was previous to the action of the venous stream².

The influence of Temperature. Moderate warmth, *ex. gr.* a temperature of 35° and a little beyond, favours muscular irritability. All the molecular processes are hastened and facilitated: the contraction is for a given stimulus greater and more rapid, *i.e.* of shorter duration. Owing to the quickening of the chemical changes, the supply of new material may prove insufficient; hence muscles removed from the body lose their irritability more rapidly at a high

¹ *Centrbt. f. Med. Wisschft.* 1864, p. 769.

² Ludwig and Schmidt, *Ludwig's Arbeiten*, 1868, p. 1.

than at a low temperature. A temperature of about 45° in the case of frogs' muscles, of 50° in the case of mammalian muscles, brings about an almost instantaneous rigor mortis, often spoken of as rigor caloris. The entrance into the rigid state is, under these circumstances, initiated by a forcible contraction or shortening.

When a muscle is exposed to cold, *ex. gr.* to a temperature very little above zero, the contractions are remarkably prolonged; they are diminished in extent at the same time, but not in proportion to the increase of their duration. Exposed to a temperature of zero or below, muscles soon lose their irritability, without however undergoing rigor mortis. After an exposure of not more than a few seconds to a temperature not much below zero, they may be restored, by gradual warmth, to an irritable condition, even though they may appear to have been frozen. When kept frozen however for some few minutes, or when exposed for a less time to temperatures of several degrees below zero, their irritability is permanently destroyed. When thawed, they enter into rigor mortis of a most pronounced character.

The influence of Functional Activity. When a muscle within the body is unused, it wastes; when used it (within certain limits) grows. Both these facts shew that the nutrition of a muscle is favourably affected by its functional activity.

Part of this may be an indirect effect of the increased blood-supply which occurs when a muscle contracts. When a nerve going to a muscle is stimulated, the blood-vessels of the muscle dilate, whether the muscle contract or no. Hence at the time of the contraction more blood flows through the muscle, and this increased flow continues for some little while after the contraction of the muscle has ceased. But besides this increased blood-supply, there are reasons for thinking that the mere contraction of the fibre is favourable to the nutritive changes which build up the muscle.

A muscle, even within the body, after prolonged action is fatigued, *i.e.* a stronger stimulus is required to produce the same contraction; in other words, its irritability is reduced by functional activity.

The fatigue of which, after prolonged or unusual exertion, we are conscious in our own bodies, arises partly from an exhaustion of muscles, partly from an exhaustion of motor nerves, but chiefly from an exhaustion of the central nervous system concerned in the production of voluntary impulses. A man who says he is absolutely exhausted may under excitement perform a very large amount of work with his already wearied muscles. He will rarely if ever call forth the greatest contractions of which the muscles are capable.

Absolute (temporary) exhaustion of the muscles, so that the strongest stimuli produce no contraction, may be produced even within the body by artificial stimulation; recovery takes place on rest. Out of the body absolute exhaustion takes place readily. Here also recovery may take place. Whether in any given case it does

occur or not, is determined by the amount of contraction causing the exhaustion, and by the previous condition of the muscle. In all cases recovery is hastened by renewal (natural or artificial) of the blood-stream. The more rapidly the contractions follow each other, the less the interval between any two contractions, the more rapid the exhaustion. A certain number of single induction-shocks repeated rapidly, say every second or oftener, bring about exhaustive loss of irritability more rapidly than the same number of shocks repeated less rapidly, for instance every 5 or 10 seconds. Hence tetanus is a ready means of producing exhaustion.

There are reasons for thinking that for each muscle it may be possible to choose such an interval between successive stimuli as shall not only not hasten, but perhaps even retard, the gradual normal exhaustion following upon removal from the body. In other words, it is probable that after a contraction there is a rebound of irritability, a reaction favourable to the nutrition of the muscle.

When a muscle is subjected to a prolonged tetanus the course of exhaustion, as indicated by the varying heights to which the load is successively raised by the repeated contractions, is at first very slow, afterwards more rapid, and finally slow again.

The amount of the load, provided this be not too great, has no marked effect on the course of exhaustion. If two muscles be loaded (after-loaded), one with a heavy, the other with a light, weight, and stimulated at the same intervals with the same stimulus, the course of exhaustion will be parallel in the two cases, though the more heavily laden muscle, responding at the outset with smaller contractions than the more lightly laden one, will be the first to enter that stage of exhaustion at which the contractions cease to be visible¹. The above is probably only true for weights up to the standard which is most favourable for the muscle's doing work: see *ante*, p. 70. Weights heavier than this quicken exhaustion—and with a certain weight the mere extension so caused, even when unaccompanied by a contraction, is exhausting.

Whether there be a third factor, *i.e.* whether muscles for instance are governed by so-called trophic nerves which affect their nutrition directly in some other way than by influencing either their blood-supply or activity, must at present be left undecided.

Muscles exhausted by prolonged action may have their irritability temporarily restored by passing through them for some time a constant current.

In exhausted muscles the elasticity is much diminished; the tired muscle returns less readily to its natural length than does the fresh one.

The exhaustion due to contraction may be the result:—(1) Either of the consumption of the store of really contractile material present in the muscle. Or (2) of the accumulation in the tissue of the products of the act of contraction. Or (3) of both of these causes.

The restorative influence of rest may be explained by supposing

¹ Kronecker, Ludwig's *Arbeiten*, 1871.

that during the repose, either the internal changes of the tissue manufacture new explosive material out of the comparatively raw material already present in the fibres, or the immediate products of the act of contraction undergo changes by which they are converted into comparatively inert bodies. A stream of fresh blood may exert its restorative influence not only by quickening the above two events, but also by carrying off the immediate waste products while at the same time it brings new raw material. It is not known to what extent each of these parts is played. That the products of contraction are exhausting in their effects, is shewn by the fact that exhausted muscles are recovered by the simple injection of inert saline solutions into their blood-vessels; and that such bodies as lactic acid injected into a muscle cause rapid exhaustion. One important element brought by fresh blood is oxygen. This, as we have seen, is not necessary for the carrying out of the actual contraction, and yet is essential to the maintenance of irritability. It is probably of use as what may be called intra-molecular oxygen¹ in preparing the explosive material whose decomposition gives rise to the carbonic acid, and other products of contraction.

It is stated by Kronecker² that oxygen, not in the form of oxyhæmoglobin, but administered roughly in the form of an injection of permanganate of potash, restores the irritability of exhausted muscle.

After prolonged artificial excitation of a muscle within the body the exhaustion is accompanied or rather followed by histological changes of the nature of degeneration.

Theory of Muscle and Nerve. The above considerations shew that when a muscle is thrown into contraction by a stimulus applied to a nerve three distinct events take place.

1. The generation and propagation of the nervous impulse along the nerve.
2. The conversion of the nervous impulse into a muscle-impulse, and the propagation of the latter along the muscular fibre.
3. The contraction started by and following upon the muscle-impulse.

The two former are very similar to each other, differing only in minor details. They are characterized by the prominence of an electrical current, by the absence of any change in the total form of the structures, and by the insignificance of the chemical changes.

The development of the electrical current is at present very imperfectly understood. Du Bois-Reymond has put forward the hypothesis that both muscle and nerve are made up of electrical molecules, in each of which the two ends are negative relatively to the equator. These are so disposed as to join in producing the total currents of the whole muscle, very much as a number of small magnets with their individual north and south poles may be built up into a large magnet with its one north and one south pole.

¹ Compare Bk. II. chap. II. sec. 5. The Respiratory changes in the Tissues.

² Ludwig's *Arbeiten*, 1871.

During a nervous or muscle-impulse it is supposed that the activity of these molecules is, in some way or other, lessened. In order to explain the phenomena of electrotonus Du Bois-Reymond further supposes that each of these molecules consists of two parts, the two positive portions of the two parts being in contact in the middle, so that the two ends of the molecule are still negative, as indicated in Fig. 15 A. When the nerve or

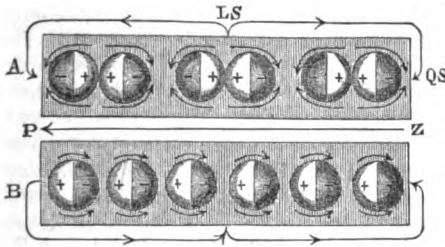

FIG. 15. DIAGRAM TO ILLUSTRATE DU BOIS-REYMOND'S THEORY OF ELECTRICAL MOLECULES IN NERVE AND MUSCLE.

A represents the natural muscle or nerve current. LS, the longitudinal (positive) section; QS, the transverse (negative) section.

B, the nerve during electrotonus. The arrows indicate the direction of the currents.

muscle is polarized one element of each molecule is reversed in the direction of the polarizing current, and the whole activity of the molecules consequently directed to produce a current in the same direction, Fig. 15 B. The objections to this hypothesis are, that complicated additions have to be made to explain why a perfectly fresh uninjured muscle exhibits little or no amount of current and yet may give a powerful negative variation, and that in a nerve the negative variation may exceed by two or three times the natural current. The alternative view of Hermann has already been referred to, p. 53. It need hardly be added, that inasmuch as the galvanometer-needle is permanently deflected so long as the electrodes of the galvanometer are in contact with the two points of different potential, the difference of potential of these points must be maintained at the expense of some form of energy within the muscle or nerve, for instance by chemical changes.

All the features of an impulse-wave either in muscle or nerve, more especially its rate of progression, shew that the electrical phenomena are in reality tokens of molecular changes in the tissue much more complex than those necessary for the propagation of a mere electrical current. An electrical current travels very much faster than a nervous impulse. It has more than once been insisted that electrical continuity is insufficient for the propagation of a nervous impulse: vital continuity is essential to its progress. The actual amount of energy developed by a most powerful nervous impulse is exceedingly slight, and hence chemical changes, insignificant in amount, may be the cause of all the phenomena, and yet remain too slight to be readily recognised. The muscular contraction itself is essentially a translocation of molecules. Thus if a portion of a muscular fibre be represented in a state of rest by four rows of molecules



Fig. 16.

with four abreast in each row, the stage of contraction might be shewn by two rows of eight abreast, Fig. 16. Whatever be the exact way in which this translocation is effected, it is fundamentally the result of a chemical

change, of what we have already seen to be an explosive decomposition of certain parts of the muscle-substance. The energy which is expended in the mechanical work done by the muscle has its source in the latent energy of the muscle-substance set free by that explosion. Concerning the nature of that explosion we only know at present that it results in the production of carbonic and lactic acids, and that heat is set free as well as the specific muscular energy. There is a general parallelism between the amount of decomposition, the quantity of carbonic (and lactic) acids produced, and the amount of energy set free. The greater the development of carbonic acid, the larger is the contraction and the higher the temperature. It has not been possible hitherto to draw up a complete equation between the latent energy of the material and the two forms of actual energy set free. By an approximate calculation Helmholtz has arrived at the conclusion that in the human body one-fifth of the energy of the material goes out as mechanical work, thus contrasting favourably with the steam-engine, in which it hardly ever amounts to more than one-tenth. Nor can we at present say that it has been experimentally verified in any given contraction that the mechanical work is done at the expense of the heat which would be otherwise given out. Thus if of two muscles *A* and *B*, *A* be not loaded and *B* loaded before a contraction and unloaded at the height of contraction, it is obvious that *A* does no work, for the muscle returns to its previous condition, while *B* does work, the more so the heavier the load and the more frequently it is raised. If now both *A* and *B* are excited by the same stimulus to equal contractions, the temperature of *A* ought to rise more than *B*, because of the same energy set free in each, some goes out as work in *B*, but in *A* none goes out as work, and all escapes as heat. Experiment shews, on the contrary, that *B* is the warmer of the two, the reason being that the tension caused by the load increases all the chemical changes in the muscle (as shewn by the increased production of carbonic acid), and thus increases the total energy set free. If *A* and *B* be equally loaded, and while *A* does no work, the load remaining on all the time, the load of *B* is removed at the height of contraction, it is then found that *A* becomes the warmer of the two. This experiment is not without objection; for *A* is (immediately after the contraction) stretched by its load, and so its chemical changes still increased, whereas *B* is not; and Heidenhain has shewn that this is sufficient to account for *A* being the warmer.

Of the exact nature of the chemical changes we know nothing. As has been already stated (p. 58), there is no evidence of nitrogenous products being given off as waste; such nitrogenous crystalline bodies as are present in muscle, kreatin, &c., may be regarded as the wear and tear of the machine, and not as products of the material consumed in the work. Yet it is hardly consonant with what we know elsewhere, to suppose that the contraction of a muscular fibre has for its essence the decomposition of a non-nitrogenous substance; and we may suppose that the explosion does involve some nitrogenous products, which however are retained within

the tissue, and used up again. Hermann, insisting on the analogy between muscular contraction and rigor mortis, has suggested the existence of a hypothetical *inogen* which during a contraction splits up into carbonic acid, lactic acid, and a nitrogenous body. He further supposes the nitrogenous body to be myosin, which however, while still in the form of a gelatinous clot, is redissolved and reconverted into inogen. But the fact that myosin has probably antecedents like those of fibrin, and is not formed directly as a product of the decomposition of a more complex body, and especially the fact that while in rigor mortis extensibility is diminished, in a contraction it is increased, seem insuperable objections to this view. It may be worth while to point out that during even the most complete repose muscle is undergoing chemical changes, which, as far as we know, are the same in kind, and only differ in degree from those characteristic of a contraction. Thus carbonic acid is constantly being produced, and probably lactic acid, both being got rid of as they form, just as they are got rid of in larger quantities during the repose which follows contraction. Supposing the existence of a substance which splits up into these various products, and which we may speak of as the true contractile material, it is evident that this material being thus constantly used up, must be as constantly repaired. Thus a stream of chemical substances may be conceived of as flowing through muscle, the raw material brought by the blood¹ being gradually converted into true contractile stuff, the breaking-down again of which is gentle and gradual so long as the muscle is at rest; when a contraction takes place, the decomposition is excessive and violent. When rigor mortis sets in, the whole remaining contractile material is decomposed. It has been already stated that according to Hermann the total quantity of carbonic and probably of lactic acid produced after removal from the body is the same whether contraction takes place or no, the material for the contraction being apparently taken away from that destined for rigor mortis. This means that the manufacture of true contractile material is suddenly arrested immediately on the cessation of the blood-current, no more being afterwards formed. Such a state of things is quite contrary to our general physiological experience, and there are other facts which render it doubtful. Lastly, it may be mentioned that no definite explanation can be given of the connection between the microscopic structure of a striated muscular fibre and its contraction. Striation is characteristic of muscles whose contraction is rapid, but the exact purpose of the striæ remains as yet unknown.

It was Haller² who laid the foundations of our knowledge of the Physiology of Muscle and Nerve by establishing the doctrine of muscular and nervous irritability. The most important results since that time have been those gained by the investigations of Weber³ on the physical changes which attend a muscular contraction, of Du Bois-Reymond⁴ on the electrical phenomena of muscle and nerve, of Helmholtz⁵ on the velocity of nervous impulses, and on the relative duration of the several phases of a

¹ Together with certain nitrogenous elements still remaining in the muscle, according to the view explained above.

² *De Part. Corp. Hum. sentientibus et irritabilibus*, 1753.

³ *Musk-bewegung*, Wagner's *Handwörterbuch*.

⁴ *Untersuch. ü. thierische Electricität*. 1848—60.

⁵ Müller's *Archiv*, 1850. *Berichte Berlin. Acad.* 1854, 1864.

contraction, of Pfüger¹ on electrotonus, of Kühne² on the chemistry of muscle, and of Hermann³ on the respiration of muscle. The researches of other and more recent authors are quoted in the previous text.

SEC. 3. UNSTRIATED MUSCULAR TISSUE.

Our knowledge of the phenomena of these structures is very imperfect, since (in vertebrates) they do not exist in isolated masses, like the striated muscles, but occur as constituents of complex organs, such as the intestine, ureter, uterus, &c. They undergo rigor mortis: and what little information we do possess concerning their chemical and physical features leads us to believe that the processes which take place in them are fundamentally identical with those occurring in striated muscle, the two differing in degree rather than in kind. When stimulated, they contract. If a stimulus, mechanical or electrical, be applied to the intestine or ureter of a mammal, a circular contraction is seen to take place at the spot stimulated. The contraction, which is preceded by a very long latent period, lasts a very considerable time, in fact several seconds, after which relaxation slowly takes place. That is to say, over the circularly dispersed fibres of the intestine (or ureter) at the spot in question there has passed a contraction-wave remarkable for its long latent period and for the slowness of its development. From the spot so directly stimulated, the contraction may pass as a wave (with a length of 1 cm. and a velocity of from 20 to 30 millimetres a second in the ureter⁴), along the circular coat both upwards and downwards. The longitudinal fibres at the spot stimulated are also thrown into contractions of altogether similar character, and a wave of contraction may also travel longitudinally along the longitudinal coat both upwards and downwards. It is evident however that the wave of contraction of which we are now speaking is in one respect different from the wave of contraction treated of in dealing with striated muscle. In the latter case the contraction-wave was one propagated along the individual fibre; in the case of the intestine or ureter, the wave is one which is propagated from fibre to fibre, both in the direction of the fibres, as when the whole circumference of the intestine is engaged in the contraction, or when the wave travels longitudinally along the longitudinal coat, and also in a direction at right angles to the axes of the fibres, as when the contraction-wave travels lengthways along the circular coat of the intestine, and passes across a breadth of the longitudinal coat. Putting aside this difference, however, it is obvious that a contraction-wave passing along even a single unstriated fibre also differs from that passing along a striated fibre, in the very great length both of its latent period and of the duration of its contraction.

¹ *Untersuch. ü. d. Physiologie des Electrotonus*, 1859.

² *Protoplasma*, 1864.

³ *Stoffwechsel im Muskel*, 1867—8.

⁴ Engelmann. *Pfüger's Archiv*, II. (1869) 243.

If the stimulus be severe when mechanical, or if the interrupted current be used as a stimulus, the duration of contraction may be still further prolonged; but there is no evidence that a series of contractions are fused into a tetanus, as is the case in the striated muscles.

The unstriated muscles seem to be remarkably susceptible to the influences of temperature. Thus according to Horvath¹ the unstriated muscles of the trachea will not contract at a temperature below 12° C. and are most active at a temperature above 21° C. So also the movements of the intestine cease at a temperature below 19° C.

Waves of contraction thus passing along the circular and longitudinal coats of the intestine give rise to what is called peristaltic action.

In striking contradistinction to what takes place in the striated muscles, automatic movements are exceedingly common in structures built up of non-striated muscles; these moreover exhibit a great tendency to rhythmic action. Thus the peristaltic action of the intestine and ureters, and the corresponding movements of the uterus, are at once rhythmic, and largely automatic. How far the automatism and the rhythm are due to nervous elements is uncertain.

Engelmann² has shewn that the middle third of the ureter in the rabbit contains no discoverable nervous structures, yet this portion exhibits automatic rhythmic contractions. It is worthy of notice, that, in the absence of all nerves, the propagation of the contraction-wave must, in this part of the ureter, be carried on by the simple contact of the adjacent surface of the fibres (which, as is known, possess no sarcolemma). The fibres, by their complete contact, are *physiologically continuous* with each other.

SEC. 4. CARDIAC MUSCLES.

The most important features of this form of contractile tissue will be studied, when we come to deal with the heart. It will be seen that they are intermediate between ordinary skeletal and non-striated muscles.

SEC. 5. CILIA.

Ciliary movement consists in the rapid flexion (into a sickle or hook-form) of the cilium and its less rapid return to its previous straight form. The diminished velocity of the return leads to the force of the ciliary action being exerted in the same direction as the flexion. The cause of the flexion is the contraction of the cilium, and the return seems to be an elastic reaction; all attempts to explain the movements by events occurring at the base of the cilium have failed. Ciliary movement seems therefore to differ from ordinary muscular contraction chiefly in the size of the apparatus concerned. The movement is exceedingly rapid: thus Engelmann³ has

¹ Pflüger's *Archiv*, XIII. (1876) 508.

² *Op. cit.*

³ *Ueber die Flimmerbewegung*, p. 22 (1868).

estimated that in the frog the flexions are repeated at least twelve times in a second. The movement in fact is too rapid to be visible; it can only be seen at a time when exhaustion and coming death have begun to retard the action; thus Engelmann found that he was first able to count them when their rapidity declined to eight in a second. The tail of a spermatozoon is practically a single cilium.

The cilia on any given surface work not only all in the same direction, but in such harmony as to produce a definite flow in the fluid covering the surface. If several cilia, or the cilia of several cells of the same surface, worked at different times they would produce nothing more than a series of small whirlpools. Cilia are in fact coordinated; but since no nervous mechanism whatever is present, the coordination can only take place through the several cells being, like the unstriated fibres spoken of just now, physiologically continuous.

In the vertebrate animal cilia are as far as we know wholly independent of the nervous system, and their movement is probably ceaseless. In such animals however as Infusoria, Hydrozoa, &c. a ciliary tract may often be seen to stop and go on again, to move fast or slow, according to the needs of the economy, and, as it almost seems, according to the will of the animal. Observations with galvanic currents, constant and interrupted, have not led to any satisfactory results, and, as far as we know at present, ciliary action is most affected by changes of temperature and chemical media. Heat quickens, cold retards. Very dilute alkalis are favourable, acids are injurious. An excess of carbonic acid or an absence of oxygen arrests the movements, either temporarily or permanently, according to the length of the exposure. Chloroform in slight doses suspends the action temporarily, in excess kills and disorganises the cells.

SEC. 6. MIGRATING CELLS.

An amœboid movement of a white corpuscle is essentially a form of contraction. In the contraction of a muscular fibre the movement of protoplasm is definite and fixed, being at right angles to the long axis of the fibres, and thus bringing about shortening and thickening. The movement of protoplasm in an amœba is irregular, and may take place in any direction.

All the circumstances which affect muscular contraction, heat, absence or presence of oxygen and carbonic acid, &c., also affect protoplasmic movements. The white corpuscles, like muscular fibres, suffer rigor mortis, in which state they become spherical.

The complete analogy between muscular fibre and white corpuscle is rendered difficult by the fact that complete rest of the corpuscle and universal contraction of the corpuscle both result in the maintenance of the same spherical form. The movement of a white corpuscle is dependent on a flow, on a contraction, of *some part*. If the whole corpuscle suffers the change which occurring in any part would lead to a movement in that part, no outward visible change takes place, just as a set of carefully balanced muscles would remain as motionless during contraction as during rest.

CHAPTER III.

THE FUNDAMENTAL PROPERTIES OF NERVOUS TISSUES.

IN its simplest, and probably earliest form, a nerve is nothing more than a thin strand of irritable protoplasm, forming the means of vital communication between a sensitive ectodermic cell exposed to extrinsic accidents, and a muscular, highly contractile cell (or a muscular process of the same cell) buried at some distance from the surface of the body, and thus less susceptible to external influences. (Fig. 17, A, B.) If in Hydra, we imagine the junction of the ectodermic

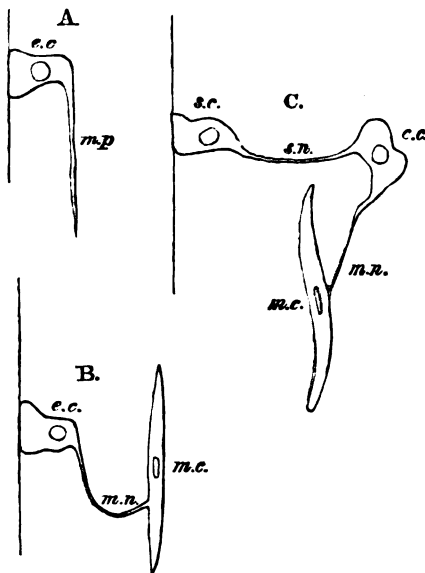

FIG. 17. DIAGRAM TO ILLUSTRATE THE SIMPLEST FORMS OF A NERVOUS SYSTEM.

- A. An ectoderm cell *e.c.*, with its muscular process *m.p.*, as in Hydra.
- B. The ectoderm cell *ec* is connected with the muscle cell *mc* by means of the primary motor nerve *mn*.
- C. The differentiated sensitive cell *sc* is connected by means of the sensory nerve *sn* with the central cell *cc*, which is again connected by means of the motor nerve *mn* with the muscle cell *mc*.

muscular process with the body of its cell to be drawn out into a thin thread (as is said to be the case in some other Hydrozoa), we should have just such a primary nerve. Since there would be no need for such a means of communication to be contractile and capable of itself changing in form, but on the other hand an advantage in its remaining immobile, and in its dimensions being reduced as much as possible consistent with the maintenance of irritability, the primary nerve would in the process of development lose the property of contractility in proportion as it became more irritable, *i.e.* more apt in the propagation of the waves of disturbance arising in the ectodermic cell¹.

We have already seen that automatism, *i.e.* the power of initiating disturbances or vital impulses, independent of any immediate disturbing event or stimulus from without, is one of the fundamental properties of protoplasm. In simpler but less exact language, such a mass of protoplasm as an amœba, though susceptible in the highest degree to influences from without, 'has a will of its own;' it executes movements which cannot be explained by reference to any changes in surrounding circumstances at the time being. A hydra has also a will of its own; and seeing that all the constituent cells (beyond the distinction into ectoderm and endoderm) are alike, we have no reason for thinking that the will resides in one cell more than in another, but are led to infer that the protoplasm of each of the cells (of the ectoderm at least) is automatic, the will of the individual being the co-ordinated wills of the component cells. In both Hydra and Amœba the processes concerned in automatic or spontaneous impulses, though in origin independent of, are subject to and largely modified by, influences proceeding from without. Indeed the great value of automatic processes in a living body depends on the automatism being affected by external influences, and on the simple effects of stimulation being profoundly modified by automatic action.

The next step of development beyond Hydra, is evidently to differentiate the single (ectodermic) cell into two cells, of which one, by division of labour, confines itself chiefly to the simple development of impulses as the result of stimulation, leaving to the other the task of automatic action, and the more complex transformation of the impulses generated in itself. The latter, which we may call the eminently automatic cell (though much of the work which it has to do is of the kind we shall presently speak of as reflex action), will naturally be withdrawn from the surface of the body, while the other, which we may call the eminently sensitive cell, will still retain its superficial position, so that it may most readily be affected by all changes in the world without, Fig. 17 C. And just as a primary *motor* nerve arises as a retained thread of communication between a sensitive cell and its muscular process, so a primary *sensory* nerve may be conceived of as arising as a thread of communication between

¹ See the valuable observations of Romanes on the movements of the Hydrozoa. *Phil. Trans.* 1876—77.

an eminently sensitive cell, and its twin the eminently automatic or central cell. By this arrangement the sensitive cell, relieved of the heavy burden of spontaneous action, is enabled to devote itself with greater vigour to the reception of external influences; while the automatic cell, no longer hampered by the physical necessities of being which are imposed on the superficial cell, exposed as this is to every wind and wave, but secure in its internal retreat, is able with similar increased energy, to devote itself either to the production of spontaneous impulses, or to profoundly modifying the impulses which it receives from the sensitive cell. Naturally the muscular process or muscular fibre would on the splitting of the original single cell remain in connection with the more eminently automatic. We thus arrive at that triple fundamental arrangement of a nervous system, in its simplest form, viz. a sensitive cell on the surface of the body connected by means of a sensory nerve with the internal automatic central nervous cell, which in turn is connected by means of a motor nerve with the muscular fibre-cell.

We have already seen that the physiology of the motor nerve cannot without inconvenience be separated from that of the muscular fibre. In the same way the physiology of the sensory nerve cannot well be separated from those modifications of superficial sensitive cells which constitute the organs of sense. We may add that the special physiology of the central nervous cells can only profitably be studied in connection with the sensory organs. In the present chapter, therefore, we purpose to confine ourselves to the consideration of the simplest and most general properties of the central nervous cells.

These are arranged in the vertebrate body in two great systems: the cerebrospinal axis, and the various ganglia scattered over the body; we shall deal with such properties only as are more or less common to the two systems. We may premise that as far as our knowledge at present goes, the processes which are concerned in the propagation of nervous impulses along a sensory nerve-trunk are identical with those which take place in a motor nerve-trunk. The phenomena of the natural nerve-current, of the negative variation during the passage of an impulse and of electrotonus (and these facts mark out, as we have seen, the limits of our information on this matter), are exactly the same, whether the piece of nerve-trunk experimented on be a mixed nerve-trunk, or an almost purely motor, or an almost purely sensory nerve-trunk, or an anterior or posterior nerve-root, or the special sensory nerve of a particular sense, such as the optic nerve. In both sensory and motor nerves the changes accompanying a nervous impulse are transmitted equally well in both directions.

We seem justified in concluding that the events which occur in a sensory nerve when it is an instrument of sensation, differ from those which take place in a motor nerve when that is an instrument of movement, only so far as the sensory impulses are generated by

particular processes which bear the stamp of the sensory cell in which they originated, while the motor impulses are generated by particular processes which bear the stamp of the central nervous cells in which they in turn originated. Just as in a muscle-nerve preparation the phenomena seen in a nerve-trunk differ according as the stimulus happens to be a constant current, or an interrupted current, or a chemical body, though they are essentially but slightly varied combinations of the same fundamental processes, so in a mixed nerve-trunk the phenomena differ according as the nervous impulses are set going by the action of a central nerve-cell, or by some agent acting directly on the nerve, or by some affection of this or that particular form of sensory cell forming part of a sense-organ. Blue and red seem to us quite different things; yet they differ in degree only—in the wave-length of their respective rays. The various forms of sensory impulses probably differ from each other and from the various forms of motor impulses in a somewhat similar way as does blue from red.

In the scheme sketched out above, the same central nervous cell is supposed to be engaged at once, both in originating automatic actions and in modifying sensory impulses (*i.e.* impulses proceeding from the superficial sensitive cells), previous to these being passed on to the muscular fibre. It is evident that, where two or more central nervous cells occur together, a further differentiation would be of advantage: a differentiation into cells which, though still susceptible of being influenced from without, should be more especially restricted to automatic action, and into cells which should forego their automatism for the sake of being more efficient in modifying sensory impulses, with a view of transmuting them into motor impulses, and so of giving rise to appropriate movements. We thus gain the fundamental and primary differentiation of the work of a central nervous system into automatic and into reflex operations. These are very clearly manifested by the brain and spinal cord, and probably also, though this is less certain, by the sporadic ganglia.

Automatic actions. In the vertebrate animal the highest form of automatism, individual volition, with which conscious intelligence is associated, is a function of certain parts of the brain. There are evidences of the existence in the brain of other forms of automatism. All these will be considered in detail hereafter.

If the spinal cord separated from the brain by division of the medulla oblongata, it becomes difficult to draw a line between purely automatic and reflex actions. Thus, when we come to deal with Respiration, we shall see that while there can be no doubt that the muscular respiratory apparatus is kept at work by impulses proceeding, in a rhythmic manner, from a group of nerve-cells, or respiratory nervous centre, in the medulla oblongata, it is an open question whether those impulses whose generation is certainly modified by centripetal impulses passing to the centre along various

nerves, are absolutely automatic: *i.e.* whether they can continue to make their appearance when no influences whatever from without are brought to bear upon the centre. Similar doubts hover round other automatic functions of the spinal cord. We shall see hereafter reasons for speaking of the existence in the medulla oblongata of a vaso-motor centre, that is of a group of nerve-cells, whence impulses habitually proceed along the so-called vaso-motor nerves to the muscular coats of the small arteries, and keep these vessels in a state of semi-contraction or tone. Here too it is doubtful whether these motor or efferent impulses can be generated in the absence of all sensory or afferent impulses. The posterior lymphatic hearts of the frog are connected by the small tenth pair of spinal nerves with the grey matter of the termination of the spinal cord, in such a manner that destruction of that part of the spinal cord or section of the tenth nerves apparently puts an end to the rhythmic pulsations of the lymphatic hearts. Here it would seem as if rhythmic impulses were automatically generated in the lower end of the cord, and proceeded along the efferent nerves to the hearts, thus determining their rhythmic pulsations. But if it be true, as asserted, that the rhythmic pulsations, though arrested for a time by severance of the nerves, or destruction of the lower end of the cord, are after a while resumed, then these, too, can be no longer counted among the automatic phenomena of the cord. And so in other instances which we shall meet with in the course of this book. The existence of automatism, then, even of this comparatively simple character, is at least doubtful. That all higher automatism comparable at least to that of the cerebral hemispheres is absent, may be regarded as certain.

In the sporadic ganglia the evidence of automatic action seems more clear, and yet is by no means absolutely decisive. The beat of the heart is a typical automatic action: and, since the heart will continue to beat for some time when isolated from the rest of the body (that of a cold-blooded animal continuing to beat for hours, or even days), its automatism must lie in its own structures. When, however, we come to discuss the beat of the heart in detail, we shall find that it is still an open question whether the automatism is confined to the ganglia (either of the sinus venosus, auricles, or auriculo-ventricular boundary), or shared in by the muscular tissue: whether, in fact, the automatism is a muscular automatism like that of a ciliated cell, or the automatism of a differentiated nerve-cell. And yet the heart is the case where the automatism of the ganglia seems clearest.

The peristaltic contractions of the alimentary canal are automatic movements; we cannot speak of them as being simply excited by the presence of food in the canal, any more than we can say that the beat of the heart is caused by the presence of blood in its cavities. When absent they may be set agoing, and when present may be stopped without any change in the contents of the canal. They may,

of course, be influenced by the contents, just as the beat of the heart is influenced by the quantity of blood in its cavities. Throughout the intestines are found the plexus of Auerbach and that of Meissner; to each or both of these the automatism of the peristaltic movements has been referred. Yet in the ureter, whose peristaltic waves of contraction closely resemble that of the intestine, automatism is evident in the middle third of its length; in which region, according to Engelmann¹, ganglia are entirely absent.

Thus, while in the spinal cord there is doubt whether purely automatic, as stringently distinguished from reflex, actions, take place, in the case of the sporadic ganglia the uncertainty is whether the clearly automatic movements of the organs with which the ganglia are associated are due to the nerve-cells of the ganglia, or to the muscular tissue itself.

Reflex actions. The spinal cord offers the best and most numerous examples of reflex action. In fact, reflex action may be said to be, *par excellence*, the function of the spinal cord; and the grey matter of the spinal cord may be broadly considered as a multitude of reflex centres. We have here to consider the cord merely in its general aspects; and must postpone the special consideration of the particular forms of reflex action which it exhibits, as they come before us in various connections, or until we have to deal with it as part of the great central nervous machinery.

In its simplest form a reflex action is as follows. All the machinery it demands is (a) a sentient surface (external or internal), connected by (b) a sensory, or—to adopt the more general and better term—afferent nerve, with (c) a central nerve-cell or group of connected nerve-cells, which is in relation by means of (d) a motor, or efferent, nerve, or nerves, with (e) a muscle, or muscles, or some other irritable tissue-elements, capable of responding by some change in their condition, to the advent of efferent impulses. The afferent impulses started in *a*, passing along *b*, reach the centre *c*, are there transmuted into efferent impulses, which, passing along *d*, finally reach *e*, and there produce a cognisable effect. The essence of a reflex action consists in the transmutation, by means of the irritable protoplasm of a nerve-cell, of afferent into efferent impulses. As an approach to a knowledge of the nature of that transmutation, we may lay down the following propositions.

The number, intensity, character and distribution of the efferent impulses is determined chiefly by the events which take place in the protoplasm of the reflex centre. It is not that the afferent impulse is simply reflected in the nerve-cell, and so becomes with but little change an efferent impulse. On the contrary, an afferent impulse passing along a single sensory fibre may give rise to efferent impulses passing along many motor nerves, and call forth the most complex movements. An instance of this disproportion of the afferent and

¹ Pflüger's *Archiv*, II, 243.

efferent impulses is seen in the case where the contact with the glottis of a foreign body so insignificant as a hair causes a violent fit of coughing. Under such circumstances a slight contact with the mucous membrane, such as could not possibly give rise to anything more than few and feeble impulses, may cause the discharge of so many efferent impulses along so many motor nerves, that not only all the respiratory muscles, but almost all the muscles of the body, are brought into action. A similar though less striking incommensurateness between the afferent and efferent impulses is seen in every reflex action. In fact, the afferent impulse when it reaches the protoplasm of the nerve produces there a series of changes, of explosive disturbances, which, except that the nerve-cell does not in any way change its form, may be likened to the explosive changes in a muscle on the arrival of an impulse along its motor nerve¹. The changes in a nerve-cell during reflex action, we might say during its activity, far more closely resemble the changes during a muscular contraction than those which accompany the passage along a nerve of either an afferent or efferent impulse. The simple passage along a nerve is accompanied by little expenditure of energy; it neither gains nor loses force to any great extent as it progresses. The transmutation in a nerve-cell is most probably (though the direct proofs are perhaps wanting) accompanied by a large expenditure of energy, and a simple nervous impulse in suffering this transmutation in a central nervous organ may accumulate in intensity to a very remarkable extent, as in the case of strychnia poisoning.

The nature of the efferent impulses is, however, determined also by the nature of the afferent impulses. The nerve-centre remaining in the same condition, the stronger or more numerous impulses will give rise to the more forcible or more comprehensive movements. Thus if the flank of a brainless frog be very lightly touched, the only reflex movement which is visible is a slight twitching of the muscles lying immediately underneath the spot of skin stimulated. If the stimulus be increased, the movements will spread to the hind-leg of the same side, which frequently will execute a movement calculated to push or wipe away the stimulus. By forcibly pinching the same spot of skin, or otherwise increasing the stimulus, the resulting movements may be led to embrace the fore-leg of the same side, then the opposite side, and finally, almost all the muscles of the body. In other words, the disturbance set going in the central nerve-cells, confined when the stimulus is slight to a few nerve-cells and to a few nerve-fibres, *overflows*, so to speak, when the stimulus is increased, on to a number of adjoining and (we must conclude) connected cells, and thus throws impulses into a large and larger number of efferent nerves.

Certain relations may be observed between the sentient spot stimulated and the resulting movement. In the simplest cases of reflex

¹ The question as to how far these processes in the central cells are connected with the development of consciousness is here purposely passed over.

action this relation is merely that the muscles thrown into action are those governed by a motor nerve which is the fellow of the sensory nerve, the stimulation of which calls forth the movement. In the more complex reflex actions of the brainless frog, and in other cases, the relation is of such a kind that the resulting movement bears an *adaptation* to the stimulus; the foot is withdrawn from the stimulus, or the movement is calculated to push or wipe away the stimulus. In other words, a certain *purpose* is evident in the reflex action.

Thus in all cases, except perhaps the very simplest, the movements called forth by a reflex action are exceedingly complex, compared with those which result from the direct stimulation of a motor trunk. When the peripheral stump of a divided sciatic nerve is stimulated with the interrupted current, the muscles of the leg are at once thrown into tetanus, continue in the same rigid condition during the passage of the current, and relax immediately on the current being shut off. When the same current is applied for a second only, to the skin of the flank of a brainless frog, the leg is drawn up and the foot rapidly swept over the spot irritated, as if to wipe away the irritation; but this movement is a complex one, requiring the contraction of particular muscles in a definite sequence, with a carefully adjusted proportion between the amounts of contraction of the individual muscles. And this complex movement, this balanced and arranged series of contractions, may be repeated more than once as the result of a single stimulation of the skin. When a deep breath is caused by a dash of cold water, the same co-ordinated and carefully arranged series of contractions is also seen to result, as part of a reflex action, from a simple stimulus. And many more examples might be given.

In such cases as these, part of the complexity may be due to the fact that the stimulus is applied to terminal sensory organs and not directly to a nerve-trunk. As we shall see in speaking of the senses, the impulses which are generated by the application of a stimulus to a sensory organ are more complex than those which result from the direct stimulation of a sensory nerve-trunk. Nevertheless, reflex actions of great if not of equal complexity may be induced by stimuli applied directly to a nerve-trunk. We are therefore obliged to conclude that in a reflex action, the processes which are originated in the central nerve-cells by the arrival of simple impulses along afferent nerves may be highly complex; and that it is the constitution and condition of the nerve-cells which determine the complexity and character of the movements which are effected. In other words, the central nerve-cells concerned in reflex actions are to be regarded as constituting a sort of molecular machinery, the character of the resulting movements being determined by the nature of the machinery set going and its condition at the time being, the character and amount of the afferent impulses determining exactly what parts of and how far the central machinery is thrown into action.

Actions of Sporadic Ganglia. Seeing that in the spinal cord, the nerve-cells undoubtedly are the central structures concerned in the production of reflex action, it is only natural to infer that the nerve-cells of the sporadic ganglia possess similar functions. Yet the evidence of this is at present of very limited extent. With regard to the ganglia on the posterior roots of the spinal nerves, all the evidence goes to shew that these possess no power whatever of reflex action. Of the larger ganglia visible to the naked eye, such as the ciliary, otic, &c., we have indications of reflex action in one only, viz. the submaxillary, and these indications are, as we shall see in treating of the salivary glands, disputed. We have no exact proof that the ganglia of the sympathetic chain, or of the larger sympathetic plexuses, are capable of executing reflex actions.

In fact, in searching for reflex actions in ganglia, we are reduced to the small microscopic groups of cells buried in the midst of the tissues to which they belong, such as the ganglia of the heart, of the intestine, the bladder, &c. When a quiescent frog's heart is stimulated by touching its surface, a beat takes place. This beat is, as we shall see, a complex, co-ordinated movement, very similar to a reflex action brought about by means of the spinal cord; and in its production it is probable that the cardiac ganglia are in some way concerned. When a quiescent intestine is touched or otherwise stimulated, peristaltic action is set up. Here again the ganglia present in the intestinal walls may be supposed to play a part; but this movement is much more simple than the beat of the heart, and as regards it, and more especially as regards the similar peristaltic action of the ureter, it becomes difficult to distinguish between a movement governed by ganglia, and one produced by direct stimulation of the muscular fibres. We have seen that the great distinction between a reflex action and a movement caused by direct stimulation of a nerve or of a muscle lies in the greater complexity of the former; and we may readily imagine, that by continued simplification of the central nervous machinery, the two might in the end become so much alike as to be almost indistinguishable.

In the vertebrate animal then the chief seat of reflex action is the spinal cord and brain. We say 'and brain' because, as we shall see later on, the brain, in addition to its automatism, is as busy a field of reflex action as the spinal cord.

Inhibition. In speaking of reflex action, we took it for granted that the spinal cord was, at the moment of the arrival of the afferent impulses at the central nerve-cells, in a quiescent state; that the nerve-cells themselves were not engaged in any automatic action. We were justified in doing so, because as far as the muscles generally of the body are concerned, the spinal cord is in a brainless frog perfectly quiescent; an afferent impulse reaching an ordinary nerve-cell of the spinal cord does not find

it preoccupied in any other business. But what happens when afferent impulses reach a nerve-cell or a group of nerve-cells already engaged in automatic action?

We have already referred to an automatic respiratory centre in the medulla oblongata. We may here premise, what we shall → shew more in detail hereafter, that the pneumogastric nerve is peculiarly associated as an afferent nerve with this respiratory centre. Now if the central end of the divided pneumogastric be stimulated at the time when the respiratory centre is engaged in its accustomed rhythmic action, sending out complex co-ordinated impulses of inspiration (and of expiration) at regular intervals, one of two things may happen, the choice of events being determined by circumstances which need not be considered here.

The most striking event, and the one which interests us now, is that the respiratory rhythm *is slowed or stopped altogether*. That is to say, that afferent impulses which, under ordinary conditions, would, on reaching a quiescent nervous centre, give rise to movement, may, under certain conditions, when brought to bear on an already active automatic nervous centre, check or stop movement by interfering with the production of efferent impulses in that centre. This stopping or checking an already present action is spoken of as an 'inhibition;' and the effect of the pneumogastric in this way on the respiratory centre is spoken of as 'the inhibitory action of the pneumogastric on the respiratory centre.'

The other event is that the respiratory rhythm is accelerated. We shall hereafter discuss the explanation of the two events. We may however premise that according to one view the pneumogastric contains among its afferent fibres two sets, which are either of a different nature from each other, or are so differently connected with the respiratory centre, that impulses arriving along one stop, while those arriving along the other quicken, the action of that centre. Hence, the one set are called 'inhibitory,' the other 'accelerating' or 'augmenting' fibres. But we are concerned at present only with the fact that the stimulation of a nerve may produce inhibitory or augmentative effects.

Similarly the vaso-motor centre in the medulla may, by impulses arriving along various afferent tracts, be inhibited, during which the muscular walls of various arteries are relaxed; or augmented, whereby the tonic contraction of various arteries is increased.

The most striking instance of inhibition is offered by the heart. If when the heart is beating well and regularly, the pneumogastric be divided, and the peripheral portion be stimulated even for a very short time with an interrupted current, the heart is immediately brought to a standstill. Its beats are arrested, it lies perfectly flaccid and motionless, and it is not till after some little time that it recommences its beat. Here again it is usually said that the pneumogastric contains efferent cardio-inhibitory fibres, impulses

passing along which from the medulla stop the automatic actions of the cardiac ganglia; the respiratory inhibitory fibres of the same nerve are afferent, *i. e.* impulses pass along them up to the medulla.

Though inhibition is most clearly seen in the case of automatic actions, other actions may be similarly inhibited. Thus, as we shall see later on, the reflex actions of the spinal cord may, by appropriate means, be inhibited.

To sum up, then, the most fundamental properties of nervous tissues.

Nerve-fibres are concerned in the propagation only, not in the origination or transformation, of nervous impulses. As far as is at present known, impulses are propagated in the same manner along both sensory and motor nerves. Sensory impulses differ from motor impulses inasmuch as the former are generated in sensory organs and pass up to the central nervous cells, while the latter pass from the central nervous cells to the muscles or to some other peripheral organs.

The operations of the nerve-cells are either automatic or reflex. In both an automatic and a reflex action, the diversity and the co-ordination of the impulses is determined by the condition of the nerve-cells. During the passage of an impulse along a nerve-fibre, there is no augmentation of energy; in passing through a nerve-cell, the augmentation may be, and generally is, most considerable.

When afferent impulses reach a centre already in action, the activity of that centre may, according to circumstances, be either depressed or exalted, may be 'inhibited' or 'augmented.'

CHAPTER IV.

THE VASCULAR MECHANISM.

IN order that the blood may be a satisfactory medium of communication between all the tissues of the body, two things are necessary. In the first place, there must be through all parts of the body a flow of blood, of a certain rapidity and general constancy. In the second place, this flow must be susceptible of both general and local modifications. In order that any tissue or organ may readily adapt itself to changes of circumstance (action, repose, &c.), it is of advantage that the quantity of blood passing to it should be not absolutely constant, but capable of variation. In order that the material equilibrium of the body may be maintained as exactly as possible, it is desirable that the loading of the blood with substances proceeding from the unwonted activity of any one tissue, should be accompanied by a greater flow of blood through some excretory or metabolic tissue by which these substances may be removed. Similarly it is of advantage to the body that the general flow of blood should in some circumstances be more energetic, and in others less so, than normal.

The first of these conditions is dependent on the mechanical and physical properties of the vascular mechanism; and the problems connected with it are almost exclusively mechanical or physical problems. The second of these conditions depends on the intervention of the nervous system; and the problems connected with it are essentially physiological problems.

I. THE PHYSICAL PHENOMENA OF THE CIRCULATION.

The **apparatus** concerned in the **Maintenance of the Normal Flow** is as follows:

1. The heart, beating rhythmically by virtue of its contractility and intrinsic mechanisms, and at each beat discharging a certain quantity of blood into the aorta. [For simplicity's sake we omit for the present the pulmonary circulation.]

2. The arteries, highly elastic throughout, with a circular muscular element increasing in relative importance as the arteries diminish in size. It must not be forgotten that the muscular element is also elastic.

When an artery divides, the united sectional area of the branches is, as a rule, larger than the sectional area of the stem. Thus the collective capacity of the arteries is continually (and rapidly) increasing from the heart towards the capillaries. If all the arterial branches were fused together, they would form a funnel, with its apex at the aorta. The united sectional area of the capillaries has been calculated by Vierordt to amount to several (eight?) hundred times that of the aorta.

3. The capillaries, channels of exceedingly small but variable size. Their walls are elastic (as shewn by their behaviour during the passage of blood-corpuscles through them), exceedingly thin and permeable. They are permeable both in the sense of allowing fluids to pass through them by osmosis, and also in the sense of allowing white and red corpuscles to traverse them. The small arteries and veins, which gradually pass into and from the capillaries properly so called, are similarly permeable, in a degree inversely proportional to their size.

4. The veins, less elastic than the arteries, and with a very variable muscular element. The united sectional area of the veins diminishes from the capillaries to the heart, thus resembling the arteries; but the united sectional area of the venæ cavæ at their embouchment into the right auricle is greater than that of the aorta at its origin. (The proportion is nearly two to one.) The total capacity of the veins is similarly much greater than that of the arteries. The veins alone can hold the total mass of blood which in life is distributed over both arteries and veins. Indeed nearly the whole blood is capable of being received by what is merely a part of the venous system, viz. the vena portæ and its branches. Such veins as are for various reasons liable to a reflux of blood from the heart towards the capillaries, are provided with valves.

SEC. 1. MAIN GENERAL FACTS OF THE CIRCULATION.

1. *The Capillary Circulation.*

If the web of a frog's foot be examined with a microscope, the blood, as judged of by the movements of the corpuscles, is seen to be passing in a continuous stream from the small arteries through the capillaries to the veins. The velocity is greater in the arteries than in the veins, and greater in both than in the capillaries. In the arteries faint pulsations, synchronous with the heart's beat, are occasionally visible; and not unfrequently variations in velocity and in the distribution of the blood, due to causes which will be hereafter discussed, are witnessed from time to time.

The flow through the smaller capillaries is very variable. Sometimes the corpuscles are seen passing through the channel (which

when collapsed may have a diameter smaller than the short axis of a red corpuscle) in single file with great regularity at a velocity of about .57 mm. in a second. (In the human retina the velocity is .75 mm. per sec. according to Vierordt.) At other times, the corpuscles which pass along a given capillary may be few and far between. Sometimes the corpuscle may remain stationary at the entrance into a capillary, the channel itself being for some little distance entirely free from corpuscles. Any one of these conditions readily passes into another, and, especially with a somewhat feeble circulation, instances of all of them may be seen in the same field of the microscope. It is only in the case of a very full circulation that all the capillaries can be seen equally filled with corpuscles. The long oval red corpuscle moves with its long axis parallel to the stream, frequently rotating on its long axis and sometimes on its short axis. The flexibility and elasticity of a corpuscle is well seen when it is being driven into a capillary narrower than itself, or when it becomes temporarily lodged at the angle between two diverging channels. The small mammalian corpuscles rotate largely as they are driven along.

In the larger capillaries, and especially in the small arteries and veins which permit the passage of several corpuscles abreast, it is observed that the red corpuscles run in the middle of the channel, forming a coloured core, between which and the sides of the vessel all round is a layer, containing no red corpuscles. In this layer, the so-called 'inert layer,' are frequently seen white corpuscles, sometimes clinging to the sides of the vessel, sometimes rolling slowly along, and in general moving irregularly, and often in jerks. This division into an inert layer and an axial stream is due to the fact that in any stream passing through a closed channel the friction is greatest at the immediate sides, and diminishes towards the axis. The corpuscles pass where the friction is least, in the axis. A quite similar axial core is seen when any fine particles are driven in a stream of fluid through a narrow tube. The phenomena cease with the flow of the fluid. Many of the white corpuscles are frequently seen in the inert layer. This is said to be due to their being specifically lighter than the red corpuscles. When fine particles of two kinds, one lighter than the other, are driven through a narrow tube, the heavier particles flow in the axis and the lighter in the more peripheral portions of the stream. The white corpuscles however are distinctly more adhesive than the red, as is seen by the manner in which they become fixed to the glass slide and cover-slip when a drop of blood is mounted for microscopical examination; and by reason of this adhesiveness they may become temporarily attached to the walls of the vessel, and consequently appear in the inert layer. The resistance to the flow of blood thus caused by the friction generated in so many minute passages, is one of the most important physical facts in the capillary circulation. In the large arteries the friction is small; it increases as they divide, and receives a very

great addition in the minute arteries and capillaries. It need perhaps hardly be said that this peripheral friction not only opposes the flow of blood through the capillaries themselves, but, working backwards along the whole arterial system, has to be met by the heart at each systole of the ventricle.

2. *The Flow in the Arteries.*

When an artery is severed, the flow from the proximal section is not equable, but comes in jets, which correspond to the heart-beats, though the flow does not cease between the jets. The blood is ejected with considerable force; thus, in Dr Stephen Hales¹ experiments, when the crural artery of a mare was severed, the jet, even after much loss of blood, rose to the height of two feet. The larger the artery and the nearer to the heart, the greater the force with which the blood issues, and the more marked the intermittence of the flow. The flow from the distal section may be very slight, or may take place with considerable force and marked intermittence, according to the amount of collateral communication.

Arterial pressure. If, while the blood is flowing normally along a large artery, *e.g.* the carotid, a mercury (or water) manometer, Fig. 18, be connected with a hole in the side of the artery, so that there is free communication between the interior of the artery and the proximal (descending) limb of the manometer, the following facts are observed.

Immediately that communication is established between the interior of the artery and the manometer, blood rushes from the former into the latter, driving some of the mercury from the descending limb into the ascending limb, and thus causing the level of the mercury in the ascending limb to rise rapidly. This rise is marked by jerks corresponding with the heart-beats. Having reached a certain level, the mercury ceases to rise any more. It does not, however, remain absolutely at rest, but undergoes oscillations; it keeps rising and falling. Each rise, which is very slight compared with the total height to which the mercury has risen, has the same rhythm as the systole of the ventricle. Similarly, each fall corresponds with the diastole.

If a float, swimming on the top of the mercury in the ascending limb of the manometer, and bearing a brush or other marker, be brought to bear on a travelling surface, some such tracing as that represented in Fig. 19 will be described. Each of the smaller curves (*p, p*) corresponds to a heart-beat, the rise corresponding to the systole and the fall to the diastole of the ventricle. The larger undulations (*r, r*) in the tracing, which are respiratory in origin, will be discussed

¹ *Statical Essays*, Vol. II. p. 2 (1732).

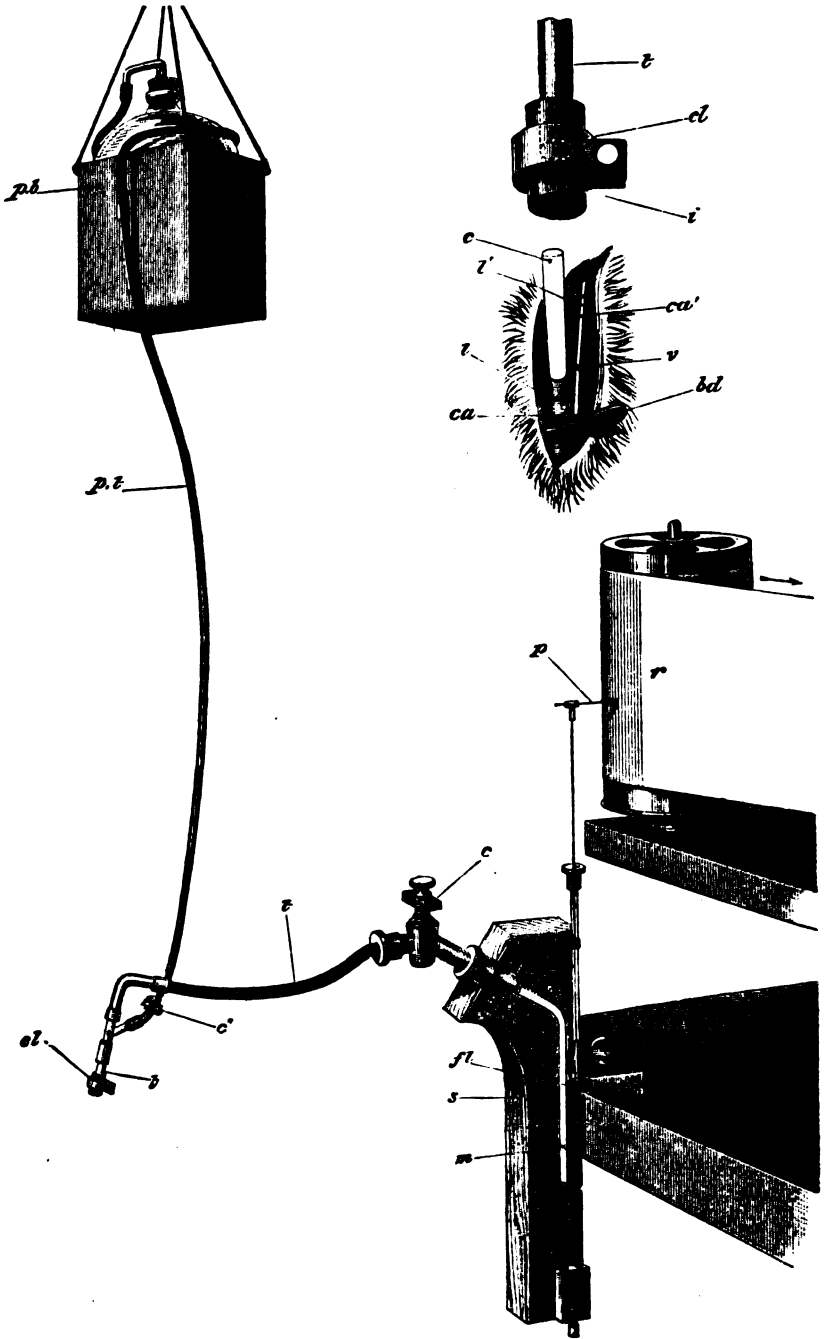

FIG. 18. APPARATUS FOR INVESTIGATING BLOOD-PRESSURE.

At the upper right-hand corner, is seen, on an enlarged scale, the carotid artery, clamped by the forceps *b d*, with the vagus nerve *v* lying by its side. The artery has been ligatured at *l'* and the glass cannula *c* has been introduced into the artery between the ligature *l'* and the forceps *b d*, and secured in position by the ligature *l*. The shrunken artery on the distal side of the cannula is seen at *ca'*.

p b is a box containing a bottle holding a saturated solution of sodium carbonate, and capable of being raised or lowered at pleasure. The solution of sodium carbonate flows by the tube *p t* regulated by the clamp *c''* into the tube *t*. The tube *t* is connected with the leaden tube *t*, and the stopcock *c* with the manometer, of which *m* is the descending and *m'* the ascending limb, and *s* the support. The mercury in the ascending limb bears on its surface the float *fl*, a long rod attached to which is fitted with the pen *p* writing on the recording surface *r*. The clamp *cl* at the end of the tube *t* has an arrangement shewn on a larger scale at the right hand upper corner.

The descending tube *m* of the manometer, and the tube *t* being completely filled along its whole length with fluid to the exclusion of all air, the cannula *c* is filled with fluid, slipped into the open end of the thick-walled india-rubber tube *i*, until it meets the tube *t* (whose position within the india-rubber tube is shewn by the dotted lines), and is then securely fixed in this position by the clamp *cl*.

The stopcocks *c* and *c''* are now opened, and the pressure-bottle raised until the mercury in the manometer is raised to the required height. The clamp *c''* is then closed and the forceps *b d* removed from the artery. The pressure of the blood in the carotid *ca* is in consequence brought to bear through *t* upon the mercury in the manometer.

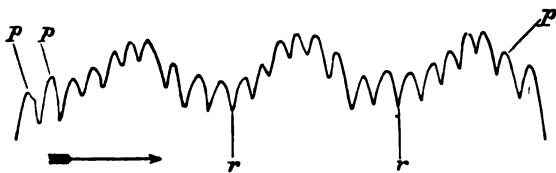

FIG. 19. TRACING OF ARTERIAL PRESSURE WITH A MERCURY MANOMETER.

The smaller curves *p p* are the pulse-curves. The space from *r* to *r* embraces a respiratory undulation.

hereafter. This observation teaches us that the blood, as it is passing along the carotid artery, is capable of supporting a column of mercury of a certain height (measured by the difference of level between the mercury in the descending limb, and that in the ascending limb, of the manometer), when the mercury is placed in direct communication with the side of the stream of blood. In other words, the blood, as it passes through the artery, exerts a lateral pressure on the sides of the artery, equal to so many millimeters of mercury. In this lateral pressure we have further to distinguish between the slighter oscillations corresponding with the heart-beats, and a *mean pressure* above and below which the oscillations range. A similar mean pressure with similar oscillations is found, when any artery of the body is examined in the same way. In all arteries the blood exerts a certain pressure on the walls of the vessels which contain it. This pressure is generally spoken of as arterial pressure, or blood-pressure (the word arterial being understood).

Description of Experiment. The carotid, or other vessel, is laid bare, clamped in two places and divided between the clamps. Into the cut ends is inserted a hollow T piece of the same bore as the artery, the cross portion forming the continuation of the artery. The vertical portion is connected by means of a non-elastic flexible tube with the descending limb of the manometer. In order to avoid loss of blood, fluid is injected into the flexible tube until the mercury in the manometer stands a very little below what may be beforehand guessed at as the probable mean pressure. The fluid chosen is a saturated solution of sodium carbonate, with a view to hinder the coagulation of the blood in the tube. When the clamps are removed from the artery the blood rushes through the cross of the T piece. Some passes into the side limb of the T piece and continues to do so until the mean pressure is quite reached. Thenceforward there is no more escape; but the pressure continues in the interior of the cross of the T piece, is transmitted along the connecting tube to the manometer, and the mercury continues to stand at a height indicative of the mean pressure with oscillations corresponding to the heart's beats. Practically the use of the T piece is found inconvenient. Accordingly the general custom is to ligature the artery, to place a clamp on the vessel on the proximal side of the ligature, and to introduce a straight cannula, Fig. 18, connected with the manometer, between the ligature and the clamp. In this case, on loosing the clamp, the whole column of blood in the artery is brought to bear on the manometer, and the tracings taken illustrate the lateral pressure not of the artery but of the vessel (aorta &c. as the case may be) of which it is itself a branch.

Tracings of the movements of the column of mercury in the manometer may be taken either on a smoked surface of a revolving cylinder (Figs. 1 and 39), or by means of a brush and ink on a continuous roll of paper, as in the more complex kymograph (Fig. 20).

The average pressure of the blood in the same body is greatest in the largest arteries, and diminishes as the arteries get less; but the fall is a very gradual one until the smallest arteries are reached, in which it becomes very rapid. In the carotid of the horse, the mean arterial pressure varies from 150 to 200 mm. of mercury; of the dog from 100 to 175; of the rabbit from 50 to 90. In the carotid of man it probably amounts to 150 or 200.

Since in all arteries the blood is pressing on the arterial walls with some considerable force, all the arteries must be in a state of permanent distension, so long as blood is flowing through them from the heart. When the blood-current is cut off, as by a ligature, this expansion or distension disappears.

Not only is there a permanent expansion corresponding to the mean pressure, but just as the mercury in the manometer rises above the level of mean pressure at each systole of the heart, and falls below it at each diastole, so at any spot in the artery there is for each heart-beat a temporary expansion succeeded by a temporary contraction, the diameter of the artery in its temporary expansions and contractions oscillating, in correspondence with the oscillations of the manometer, beyond and within the diameter of permanent expansion.

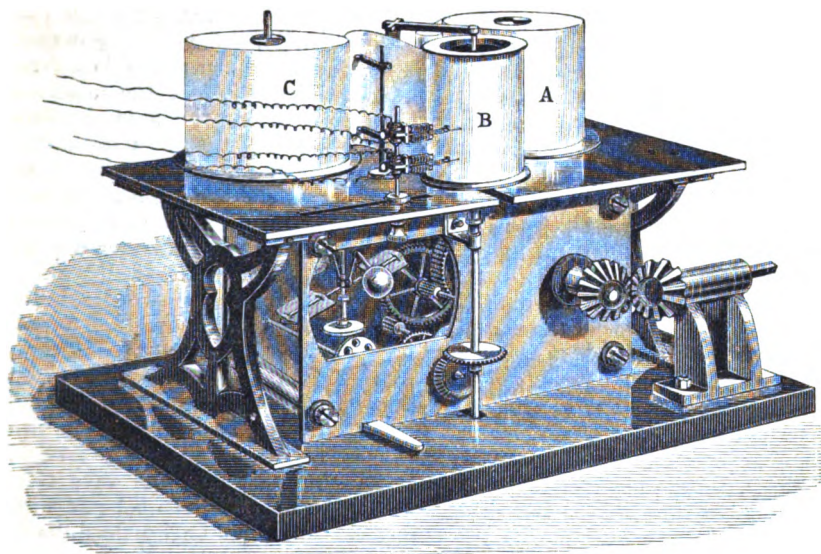

FIG. 20. LARGE KYMOGRAPH WITH CONTINUOUS ROLL OF PAPER.

The clock-work machinery, some of the details of which are seen, unrolls the paper from the roll C, carries it smoothly over the cylinder B, and then winds it up into the roll A.

Two electromagnetic signals are seen in the position in which they record their movements on the paper as it travels over B. The manometer, or any other recording instrument used, can be fixed either in the notch immediately in front of B or in any other position that may be desired.

These temporary expansions constitute what is called the pulse, and will be discussed more fully hereafter.

The velocity of the flow. When even a small artery is severed, a considerable quantity of blood escapes from the proximal cut end in a very short space of time. That is to say, the blood moves in the arteries from the heart to the capillaries, with a very considerable velocity. By various methods, this velocity of the blood-current has been measured at different parts of the arterial system; the results, owing to imperfections in the methods employed, cannot be regarded as satisfactorily exact, but may be accepted as approximatively true. The velocity of the arterial stream is greatest in the largest arteries, and diminishes from the heart to the capillaries, *pari passu* with the increase, so to speak, of the width of the bed, *i.e.* with the increase of the united sectional area.

Methods. The Hæmadromometer of Volkmann. An artery, *e.g.* a carotid, is clamped in two places, and divided between the clamps. Two cannulæ, of a bore as nearly equal as possible to that of the artery, or of a known bore, are inserted in the two ends. The two cannulæ are con-

ected by means of two stop-cocks, which work together, with the two ends of a long glass tube, bent in the shape of a U, and filled with water, or with a coloured innocuous fluid. The clamps on the artery being released, a turn of the stop-cocks permits the blood to enter the proximal end of the long U tube, along which it courses, driving the fluid out into the artery through the distal end. Attached to the tube is a graduated scale, by means of which the velocity with which the blood flows *along the tube* may be read off. Even supposing the cannulae to be of the same bore as the artery, it is evident that the conditions of the flow through the tube are such as will only admit of the result thus gained being considered as an approximative estimation of the real velocity in the artery itself.

The Rheometer (Stromuhr) of Ludwig. This consists of two glass bulbs *A* and *B*, Fig. 21, communicating above with each other and with the common tube *C* by which they can be filled. Their lower ends are fixed in the metal disc *D*, which can be made to rotate, through two right angles, round the lower disc *E*. In the upper disc are two holes *a* and *b* continuous with *A* and *B* respectively, and in the lower disc are two similar holes *a'* and *b'*, similarly continuous with the tubes *H* and *G*. Hence, in the position of the discs shewn in the figure, the tube *G* is continuous through the two discs with the bulb *A* and the tube *H* with the bulb *B*. On turning the disc *D* through two right angles the tube *G* becomes continuous with *B* instead of *A*, and the tube *H* with *A* instead of *B*. There is a further arrangement, omitted from the figure for the sake of simplicity, by which when the disc *D* is turned through one instead of two right angles from either of the above positions, *G* becomes directly continuous with *H*, both being completely shut off from the bulbs.

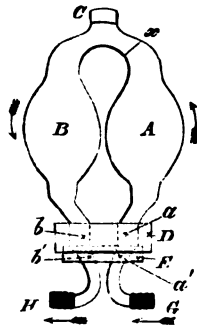

FIG. 21. DIAGRAMMATIC REPRESENTATION OF LUDWIG'S STROMUHR.

The ends of the tubes *H* and *G* are made to fit exactly into two cannulae inserted into the two cut ends of the artery about to be experimented upon, and having a bore as nearly equal as possible to that of the artery.

The method of experimenting is as follows. The disc *D*, being placed in the intermediate position, so that *a* and *b* are both cut off from *a'* and *b'*, the bulb *A* is filled with pure olive oil up to the mark *x*, and the bulb *B*, the rest of *A*, and the junction *C*, with defibrinated blood; and *C* is then clamped. The tubes *H* and *G* are also filled with defibrinated blood, and *G* is inserted into the cannula of the central, *H* into that of the

peripheral, end of the artery. On removing the clamps from the artery the blood flows through *G* to *H*, and so back into the artery. The observation now begins by turning the disc *D* into the position shewn in the figure; the blood then flows into *A*, driving the oil there contained out before it into the bulb *B*, in the direction of the arrow, the defibrinated blood previously present in *B* passing by *H* into the artery, and so into the system. At the moment that the blood is seen to rise to the mark *x*, the disc *D* is with all possible rapidity turned through two right angles; and thus the bulb *B*, now largely filled with oil, placed in communication with *G*. The blood-stream now drives the oil back into *A*, and the new blood in *A* through *H* into the artery. As soon as the oil has wholly returned to *A*, the disc is again turned round, and *A* once more placed in communication with *G*, and the oil once more driven from *A* to *B*. And this is repeated several times, indeed generally until the clotting of the blood or the admixture of the oil with the blood puts an end to the experiment. Thus the flow of blood is used to fill alternately with blood or oil the space of the bulb *A*, whose cavity as far as the mark *x* has been exactly measured; hence if the number of times a second the disc *D* has to be turned round be known, the number of times *A* has been filled in any given time is also known, and thus the quantity of blood which has passed in that time through the cannula connected with the tube *G* is directly measured. For instance, supposing that the quantity held by the bulb *A* when filled up to the mark *x* is 5 cc., and supposing that from the moment of allowing the first 5 cc. of blood to begin to enter the tube to the moment when the escape of the last 5 cc. from the artery into the tube was complete, 100 seconds had elapsed, during which time 5 cc. had been received 10 times into the tube from the artery (all but the last 5 cc. being returned into the distal portion of the artery), obviously .5 cc. of blood had flowed from the proximal section of the artery in one second. Hence supposing that the diameter of the cannula (and of the artery, they being the same) were 2 mm., with a sectional area therefore of 3.14 square mm., an outflow through the section of .5 cc. or 500 c.mm. in a second would give ($\frac{500}{3.14}$), a velocity of about 159 mm. in a second.

The Hæmatachometer of Vierordt is constructed on the principle of measuring the velocity of the current by observing the amount of deviation undergone by a pendulum, the free end of which hangs loosely in the stream. A square or rectangular chamber, one side at least is of glass in order that the interior may be visible, is connected by means of two short tubes with the two cut ends of an artery; the blood consequently flows from the proximal (central) portion of the artery through the chamber into the distal portion of the artery. Within the chamber and suspended from its roof is a short pendulum, the ball of which bears a pointed projection to serve as a marker. When the blood-stream is cut off from the chamber the pendulum hangs motionless in a vertical position. When the blood is allowed to flow through the chamber, the pendulum is driven by the force of the current out of its position of rest, the point attached to the ball of the pendulum describing an arc of a circle. The more rapid the flow the greater will be the deviation, and by placing in the path of the marker a graduated scale, the amount of deviation (which is continually varying) may, at any moment, be read off. The graduation of the scale having been carried out by experimenting with streams of known velocity, the velocity can at once be calculated from the amount of deviation.

An instrument based on the same principle has been invented by Chauveau and improved by Lortet. In this the part which corresponds to the pendulum in Vierordt's instrument is prolonged outside the chamber, and thus the portion within the chamber is made to form the short arm of a lever, the fulcrum of which is at the point where the wall of the chamber is traversed and the long arm of which projects outside. A somewhat wide tube, the wall of which is at one point composed of an india-rubber membrane, is introduced into the two cut ends of an artery. A long light lever pierces the india-rubber membrane. The short expanded arm of this lever projecting within the tube is moved on its fulcrum in the india-rubber ring by the current of blood passing through the tube, the greater the velocity of the current, the larger being the excursions of the lever. The movements of the short arm give rise to corresponding movements in the opposite direction of the long arm outside the tube, and these, by means of a marker attached to the end of the long arm, may be directly inscribed on a recording surface. This instrument is very well adapted for observing changes in the velocity of the flow. In determining actual velocities, for which purpose it has to be experimentally graduated, it is not so useful.

In the horse, Volkmann found the velocity of the stream to be in the carotid artery about 300 mm., in the maxillary artery 165 mm., and in the metatarsal artery 56 mm. in the second. Chauveau determined the velocity in the carotid of the horse to vary from 520 to 150 mm. per sec. at each beat of the heart, flowing at the former rate during the height of each pulse-expansion, and at the latter in the interval between each two beats. Ludwig and Dogiel found the velocity in the dog and in the rabbit to vary within very wide limits, not only in different arteries, but in the same artery under different circumstances. Thus while in the carotid of the rabbit it may be said to vary from 100 to 200 mm. per sec., and in the carotid of the dog from 200 to 500 mm. per sec., both these limits were frequently passed.

3. *The Flow in the Veins.*

When a vein is severed, the flow from the distal cut end (*i.e.* the end nearest the capillaries) is continuous, the blood is ejected with comparatively little force, and with slight velocity.

When a vein is connected with a manometer, the lateral pressure is found to be very small; it is greater in the veins farther from the heart than in those nearer the heart. In the immediate neighbourhood of the heart the pressure may (during the inspiratory movement) become negative, *i.e.* when the manometer is brought into connection with the interior of the vein, the mercury in the distal limb falls, instead of, as in the case of the artery, rising.

In the brachial vein of the sheep Jacobson found the mean pressure to be 4 mm. of mercury, in a branch of the same 9 mm. In the crural it was 11.4 mm. In the subclavian the mean pressure was negative, *viz.* -1 mm., becoming -1 mm. during inspiration, -3 mm. or -5 mm. during a strong inspiration, and changing to positive during expiration.

The level of mercury in the manometer, except in the case of certain veins, subject to influences which will be discussed hereafter, remains constant. The pulse-oscillations, so striking in the arteries, are absent in the veins. In the small veins the velocity of the current, measured in the same way as the arteries, is very slight. It increases in the larger veins, corresponding to the diminution of the area of 'the bed'; it is about 200 mm. per sec. in the jugular vein of the dog.

Thus the flow in the veins presents strong contrasts with that in the arteries. In the arteries, even in the smallest branches, there is a considerable mean pressure. In the veins, even in the small veins where it is largest, the mean pressure is very slight. In other words, there is always a difference of pressure tending to make the blood flow continuously from the arteries into the veins. A pulse is present in the arteries, but, with the exceptions alluded to, absent in the veins. The velocity of the stream of blood in the arteries is very considerable; in the veins, especially the smaller veins, much less; in both it corresponds with the area of the bed, diminishing in the former from the heart to the capillaries, and increasing in the latter from the capillaries to the heart.

Hydraulic Principles of the Circulation.

E. C. C. C.

All the above phenomena are the simple results of an intermittent force (like that of the systole of the ventricle) working in a closed circuit of branching elastic tubes, so arranged that while the individual tubes first diminish (from the heart to the capillaries) and then increase (from the capillaries to the heart), the area of the bed first increases and then diminishes, the tubes together thus forming two cones placed base to base at the capillaries, with their apices converging to the heart. To this it must be added that the friction, in the small arteries or capillaries, at the junction of the bases of the cones, offers a very great resistance to the flow of the blood through them. It is this peripheral resistance (in the minute arteries and capillaries), reacting through the elastic walls of the arteries upon the intermittent force of the heart, which gives the circulation of the blood its peculiar features.

When fluid is driven by an intermittent force, as by a pump, through a perfectly rigid tube (or system of tubes), at each stroke of the pump there escapes from the distal end of the system just as much fluid as enters it at the proximal end. The escape moreover takes place at the same time as the entrance, since the time taken up by the transmission of the *shock* is so small, that it may be neglected. This result remains the same when any resistance to the flow is introduced into the system. The force of the pump remaining the same, the introduction of the resistance undoubtedly lessens the quantity issuing at the distal end at each stroke, but it does so simply by lessening the quantity entering at the proximal

end; the income and outgo remain equal to each other, and occur at almost the same time. And what is true of the two ends, is also true of any part of the course of the system, so far, at all events, as the following proposition is concerned, that in a system of rigid tubes, either with or without an intercalated resistance, the flow caused by an intermittent force is, in every part of the tubes, intermittent synchronously with that force.

In a system of elastic tubes in which there is little resistance to the progress of the fluid, the flow caused by an intermittent force is also intermittent. The outgo being as easy or nearly as easy as the income, the elasticity of the walls of the tubes is not called into play. These behave practically like rigid tubes. When, however, sufficient resistance is introduced into any part of the course, the fluid, being unable to pass by the resistance as rapidly as it enters the system from the pump, tends to accumulate on the proximal side of the resistance. This it is able to do by expanding the elastic walls of the tubes. At each stroke of the pump a certain quantity of fluid enters the system at the proximal end. Of this only a fraction can pass through the resistance during the stroke. At the moment when the stroke ceases, the rest still remains on the proximal side of the resistance, the elastic tubes having expanded to receive it. During the interval between this and the next stroke, the distended elastic tubes, striving to return to their natural undistended condition, press on this extra quantity of fluid which they contain and tend to drive it past the resistance. Thus in the rigid system (and in the elastic system without resistance) there issues, from the distal end of the system, at each stroke just as much fluid as enters it at the proximal end, while between the strokes there is perfect quiet. In the elastic system with resistance, on the contrary, the quantity which passes the resistance is only a fraction of that which enters the system from the pump, the remainder or a portion of the remainder continuing to pass during the interval between the strokes. In the former case, the system is no fuller at the end of the stroke than at the beginning; in the latter case there is an accumulation of fluid between the pump and the resistance, and a corresponding distension of that part of the system, at the close of each stroke—an accumulation and distension, however, which go on diminishing until the next stroke comes. The amount of fluid thus remaining after the stroke will depend on the amount of resistance in relation to the force of the stroke, and on the distensibility of the tubes; and the amount which passes the resistance before the next stroke will depend on the degree of elastic reaction of which the tubes are capable. Thus, if the resistance be very considerable in relation to the force of the stroke, and the tubes very distensible, only a small portion of the fluid will pass the resistance, the greater part remaining lodged between the pump and the resistance. If the elastic reaction be great, a large portion of this will be passed on through the resistance before the next stroke comes. In other words, the

greater the resistance (in relation to the force of the stroke), and the greater the elastic force brought into play, the less intermittent, the more nearly continuous, will be the flow on the far side of the resistance.

If the first stroke be succeeded by a second stroke before its quantity of fluid has all passed by the resistance, there will be an additional accumulation of fluid on the near side of the resistance, an additional distension of the tubes, an additional strain on their elastic powers, and, in consequence, the flow between this second stroke and the third will be even more marked than that between the first and the second, though all three strokes were of the same force, the addition being due to the extra amount of elastic force called into play. In fact, it is evident that, if there be a sufficient store of elastic power to fall back upon, by continually repeating the strokes, a state of things will be at last arrived at, in which the elastic force, called into play by the continually increasing distension of the tubes on the near side of the resistance, will be sufficient to drive through the resistance, in the interval between each two strokes, just as much fluid as enters the near end of the system at each stroke. In other words, the elastic reaction of the walls of the tubes will have converted the intermittent into a continuous flow. The flow on the far side of the resistance is in this case not the direct result of the strokes of the pump. All the force of the pump is spent, first in getting up, and afterwards in keeping up, the over-distension of the tubes on the near side of the resistance; it is the over-distended tubes which are the cause of the continuous flow, by emptying themselves into the far side of the resistance, at such a rate, that they discharge through the resistance during a stroke and in the succeeding interval just as much as they receive from the pump by the stroke itself.

This is exactly what takes place in the vascular system. The friction in the minute arteries and capillaries presents a considerable resistance to the flow of blood through them into the small veins. In consequence of this resistance, the force of the heart's beat is spent in maintaining the whole of the arterial system in a state of over-distension, as indicated by the so-called arterial pressure. The over-distended arterial system is, by the agency of its elastic walls, continually emptying itself by overflowing through the capillaries into the venous system, overflowing at such a rate, that just as much blood passes from the arteries to the veins during each systole and its succeeding diastole as enters the aorta at each systole.

It cannot be too much insisted upon that the whole arterial system is *overfull*. This is what is meant by the high arterial pressure. On the other hand, the veins are much less full. This is shewn by the low venous pressure. The overfull arteries are continually striving to pass their surplus in a continuous stream through the capillaries into the veins, so as to bring both venous and arterial pressure to the same level. As continually the heart by

its beat is keeping the arteries overfull, and thus maintaining the difference between the arterial and venous pressure, and thus preserving the steady capillary stream. When the heart ceases to beat, the arteries do succeed in emptying their surplus into the veins, and when the pressure on both sides of the capillaries is thus equalized, the flow through the capillaries ceases.

In the facts just discussed, it makes no essential difference whether the outflow on the far side of the resistance be an open one, or whether, as is the case in the vascular system, the fluid be returned to the pump, provided only that the resistance offered to that return be sufficiently small. We shall see, in speaking of the heart, that, so far from there being any resistance to the flow of blood from the great veins into the auricle, the flow is favoured by a variety of circumstances. We have seen moreover that, besides the very sudden decrease in the immediate neighbourhood of the capillaries, there is in passing along the whole vascular system from the aorta to the *venæ cavæ* a gradual fall of pressure. A little consideration shews that this must be the case. After what has been said it is obvious that the movement of the blood may be compared to that of a body of fluid, driven by pressure from the ventricle through the vessels to its outflow in the auricle. Were the pressure a continuous one, and were there no capillary resistance, there would be a gradual fall of pressure, from the part farthest from the outfall, viz. the aorta, to the part nearest the outfall, viz. the *venæ cavæ*. The introduction of the capillary resistance and its attendant phenomena gives rise to the feature of a very sudden and marked fall in the capillary region, but leaves untouched the gradual character of the fall in the rest of the course, from the aorta to the minute arteries, and from the minute veins to the *venæ cavæ*.

To recapitulate: there are three chief factors in the mechanics of the circulation, (1) the force and frequency of the heart-beat, (2) the peripheral resistance, (3) the elasticity of the arterial walls. These three factors, in order to produce a normal circulation, must be in a certain relation to each other. A disturbance of these relations brings about abnormal conditions. Thus, if the capillary resistance be reduced beyond certain limits, while the force and frequency of the heart remain the same, so much blood passes through the capillaries at each stroke of the heart that there is not sufficient left behind to distend the arteries, and bring their elasticity into play. In this case the intermittence of the arterial flow is continued on into the veins. An instance of this is seen in the experiments on the submaxillary gland, where sometimes the capillary resistance in the gland is so much lowered, that the blood in the veins pulsates¹. A like result occurs when, the capillary resistance remaining the same, the force or frequency of the heart's beat is lowered. Thus the beats may be so feeble that at each stroke no more blood, or but little more,

¹ See Book I. cap. I. sec. 2, on the Secretion of the Digestive Juices.

enters the arterial system than can pass through the capillaries before the next stroke; or so infrequent that the whole quantity sent on by a stroke has time to escape before the next stroke comes. If, while the heart's beat and resistance remain the same, the elasticity of the arterial walls be reduced, the arteries will be unable to expand sufficiently to retain the surplus of each stroke or to exert sufficient elastic reaction to carry forward the stream between the strokes; and in consequence more or less intermittence will become manifest.

Marey¹ states that when fluid is driven through two tubes of equal calibre, one elastic and the other rigid, with equal force and like intermittence, the outflow through the elastic tube is greater than through the rigid tube. This he attributes to the fact that in the rigid tube all the friction falls in the period of the stroke, when the velocity of the stream is greatest, and is therefore greater than in the elastic tube where it is distributed as well over the interval between the strokes. Under this view, the arrangements of the vascular system are useful, not only in causing the flow through the capillaries to be continuous, and therefore best adapted for carrying on the interchange between the tissues and the blood, but also in providing that the flow should be as large as possible.

The velocity of the stream. Observation shews that the velocity of the blood-stream diminishes from the aorta to the capillaries, and increases from the capillaries to the great veins. Thus in the dog the velocity in the great arteries may be stated at from 300 to 500 mm., in the capillaries at less than 1 mm. ($\cdot 5$ to $\cdot 75$ mm.), and in the large veins at about 200 mm. in a sec. In fact, the greater part of the time of the circuit is taken up in the capillary region. An iron salt, injected into the jugular vein of one side of the neck of a horse, makes its appearance in the blood of the jugular vein of the other side in about 30 seconds.

Hering's mean result in the horse was 27·6 secs. In the dog Vierordt found it to be 15·2 secs.; in the rabbit 7 secs.

Without laying too much stress on this experiment, it may be taken as a fair indication of the time in which the whole circuit may be completed. It takes about the same time (see p. 98) to pass through about 20 mm. of capillaries. Hence, if any corpuscle had in its circuit to pass through 10 mm. of capillaries, half the whole time of its journey would be spent in the narrow channels of the capillaries. Since, however, the average length of a capillary is about $\cdot 5$ mm., about one second is spent in the capillaries. Inasmuch as the purposes served by the blood are chiefly carried out in the capillaries, it is obviously of advantage that its stay in them should be prolonged.

The *permanent* variations in the velocity of the stream are directly dependent on the area of the 'bed.' When a fluid is driven by a uniform pressure through a narrow tube with an enlargement in the

¹ *Ann. Sci. Nat.* (iv.) viii. p. 329.

middle, the velocity of the stream will be found to diminish in the enlargement, but to increase again when the tube once more narrows. So a river slackens speed in a broad, but rushes on rapidly again when the banks close in. Exactly in the same way the velocity of the blood-stream slackens from the aorta to the capillaries corresponding with the increased total bed, but hurries on again as the numerous veins are gathered into the smaller bed of the *venæ cavæ*. The loss of velocity in the capillaries, as compared with the arteries, is not due to there being so much more friction in the narrow channels of the former than in the wide canals of the latter. For the peripheral resistance caused by the friction in the capillaries and small arteries is an obstacle not only to the flow of blood through these small vessels where the resistance is actually generated, but also to the escape of the blood from the large into the small arteries, and indeed from the heart into the large arteries. It exerts its influence along the whole arterial tract. And it is obvious that if it were this peripheral resistance which checked the flow in the capillaries, there could be no recovery of velocity along the venous tract. The rapidity of the flow in arteries, capillaries, and veins, is in each case determined by the total sectional area of the channels. There is, however, a loss of velocity on the whole course. At each stroke as much blood enters the right auricle as issues from the left ventricle; but the sectional area of the *venæ cavæ* is greater than that of the aorta, so that even if the auricle were filled in exactly the same time as the ventricle is emptied, the blood must pass more rapidly through the narrow aorta than through the broad *venæ cavæ*, in order that the same quantity of blood should pass each at the same time. The diastole of the auricle, however, is distinctly longer than the systole of the ventricle; the time during which the auricle is being filled is greater than that during which the ventricle is being emptied, and hence the velocity of the venous flow into the auricle must be still less than that of the arterial blood in the commencing aorta.

The *temporary* variations of the velocity of the stream in any given channel, and these we have already (p. 106) seen to be very considerable in the case of the arteries at least, are dependent on a variety of circumstances. In a tube of constant calibre, the velocity with which fluid flows from one point to another, for instance from the point *a* to the point *b*, will be in main dependent on the difference between the pressures existing at *a* and *b*. The lower the pressure at *b* as compared with *a* the greater the rapidity with which the fluid flows from *a* to *b*. And temporary variations of pressures form undoubtedly the main cause of the temporary variations observable in the velocity of the arterial flow. Thus with each systole of the ventricle there is an increase of velocity in the whole arterial flow followed by a diminution during the diastole. So also if the peripheral resistance in a capillary district belonging to an artery be suddenly lowered (by the action of vaso-motor nerves, in a manner which we shall presently discuss), *without the calibre of the artery*

itself being changed, the pressure on the distal (peripheral) side of the artery may be much diminished, while the pressure on the proximal (cardiac) side remains at first unaltered; and this would necessarily cause an increase in the rapidity of the stream through that artery. But, as we shall see later on, from the complications of the vascular machinery such problems as these become very intricate; and the results of observations on variations in arterial velocity are not altogether intelligible. It has been suggested that varying conditions of the blood may be an important factor in determining the variations in the velocity of the stream¹.

SEC. 2. THE HEART.

The heart is a pump, the motive power of which is supplied by the contraction of its muscular fibres. Its action consequently presents problems which are partly mechanical, and partly vital. Regarded as a pump, its effects are determined by the frequency of the beats, by the force of each beat, by the character of each beat—whether, for instance, slow and lingering, or sudden and sharp—and by the quantity of fluid ejected at each beat. Hence, with a given frequency, force, and character of beat, and a given quantity ejected at each beat, the problems which have to be dealt with are for the most part mechanical. The vital problems are chiefly connected with the causes which determine the frequency, force, and character of the beat. The quantity ejected at each beat is governed more by the state of the rest of the body, than by that of the heart itself.

The Phenomena of the normal Beat.

The visible movements. When the chest of a mammal is opened and artificial respiration kept up, a complete beat of the whole heart, or cardiac cycle, may be observed to take place as follows.

The great veins, inferior and superior venæ cavæ and pulmonary veins, are seen, while full of blood, to contract in the neighbourhood of the heart: the contraction runs in a peristaltic wave towards the auricles, increasing in intensity as it goes. Arrived at the auricles, which are then full of blood, the wave suddenly spreads, at a rate too rapid to be fairly judged by the eye, over the whole of those organs, which accordingly contract with a sudden sharp systole. In the systole, the walls of the auricles press towards the auriculo-ventricular orifices, and the auricular appendages are drawn inwards, becoming smaller and paler. During the auricular systole, the ventricles may be seen to become more and more turgid. Then follows, as it were immediately, the ventricular systole, during which the ventricles become shorter and thicker. Held between the fingers they are felt to become tense and hard. As the systole progresses,

¹ Ludwig and Dogiel. Ludwig's *Arbeiten*, 1867.

the aorta and pulmonary arteries are seen to expand and elongate, and the heart to twist slightly on its long axis, so that, while the base is fixed by the great arteries, the apex moves from the left and behind towards the front and right; hence more of the left ventricle becomes displayed. As the systole gives way to the succeeding pause or diastole, the ventricles flatten and elongate, the aorta and pulmonary artery contract and shorten, the heart turns back towards the left, and thus the cycle is completed.

More exact observation shews, as regards the change of form of the ventricular portion, that this, during diastole, has somewhat the shape of a flattened cone, with an ellipse, having its long diameter from right to left, as a base, but during the systole becomes a shorter, more regular, cone, with a circle for its base, having lessened chiefly in its longitudinal and right-to-left diameters, and slightly only in its antero-posterior diameter. According to Kürschner¹, the circumference of the base of the ventricle is absolutely increased during the systole; a tape placed round the base becomes tense at the commencement of the systole, while the cavity is still full of blood.

When the chest is opened, the heart is deprived of its natural supports, and consequently, under such circumstances, its change of position during the systole cannot be properly studied. For it must be remembered that the heart, closely covered by the pericardium, lies immediately under the sternum and ribs, there being between them nothing more than a small amount of mediastinal connective tissue, and rests on the slope of the diaphragm below, with the lungs on either side. If, in the unopened chest of a rabbit or dog, three needles be inserted through the chest-wall so that their points are plunged into the substance of the ventricle, one (B) at the base, close to the auricles, another (A) through the apex, and a third (M) at about the middle of the ventricle, all three needles will be observed to move at each beat of the heart. The head of B will move suddenly upwards, shewing that the point of the needle plunged in the ventricle moves downwards, whereas A will only quiver, and move neither distinctly upwards nor downwards. M will move upwards (and therefore its point downwards), but not to the same extent as B. The nearer to B, M is, the more it moves: the nearer to A, the less. Thus, while during the beat, the base (B) moves downwards as the result of the contraction (and longitudinal shortening) of the ventricle, the apex (A) does not change its place, the shortening of the ventricle itself being compensated by the lengthening of the great arteries. The middle of the ventricle moves downwards more than the apex, but less than the extreme base. After the death of the animal, the needles, if properly inserted at first, perpendicular to the chest, will be found with all their heads directed downwards, indicating that the whole ventricle has been

¹ Wagner's *Handwörterbuch*, Art. *Herzthätigkeit*.

drawn up by the contraction of the empty aorta and pulmonary artery.

Cardiac Impulse. If the hand be placed on the chest, a shock or impulse will be felt at each beat, and on examination this impulse, 'cardiac impulse,' will be found to be synchronous with the systole of the ventricle. In man, the cardiac impulse may be most distinctly felt in the fifth costal interspace, about an inch below and a little to the median side of the left nipple. The same impulse may be felt in an animal by making an incision through the diaphragm from the abdomen, and placing the finger between the chest-wall and the apex. It then can be distinctly recognized as the result of the hardening of the ventricle during the systole. And the impulse which is felt on the outside of the chest is the same hardening of the stationary portion of the ventricle in contact with the chest-wall, transmitted through the chest-wall to the finger. In its flaccid state, during diastole, the apex is (in a standing position at least) here in contact with the chest-wall, lying between it and the tolerably resistant diaphragm. During the systole, while occupying, as we have seen, the same position, it suddenly grows tense and hard. The ventricles, in executing their systole, have to contract against resistance. They have to produce within their cavities, tensions greater than those in the aorta and pulmonary arteries, respectively. This is, in fact, the object of the systole. Hence, during the swift systole, the ventricular portion of the heart becomes suddenly tense, just as a bladder full of fluid would become tense and hard when forcibly squeezed. This sudden hardness gives an impulse or shock both to the chest-wall and to the diaphragm, which may be felt readily both on the chest-wall, and also through the diaphragm when the abdomen is opened, and the finger inserted. If the modification of the sphygmograph (see section on Pulse), called the cardiograph, be placed on the spot where the impulse is felt most strongly, the lever is seen to be raised during the systole of the ventricles, and to fall again as the systole passes away, very much as if it were placed on the heart directly. A tracing may thus be obtained (Fig. 22), of which we shall have to speak more fully immediately. If the button of the lever be placed, not on the exact spot of the impulse, but at a little distance from it, the lever will be *depressed* during the systole. While at the spot of impulse itself the contact of the ventricle is increased during systole, away from the spot the ventricle retires from the chest-wall (by the diminution of its right-to-left diameter), and hence, by the mediastinal attachments of the pericardium, draws the chest-wall after it.

Endo-cardiac pressure. In order to study more fully the changes going on in the heart during the cardiac cycle, it becomes necessary to know something of what is taking place in the interior of the cavities of the heart. At present, our chief information on this head

is derived from the experiments of Chauveau and Marey¹. By introducing into the right auricle and ventricle respectively of the horse, through the jugular vein, small elastic bags, each communicating with

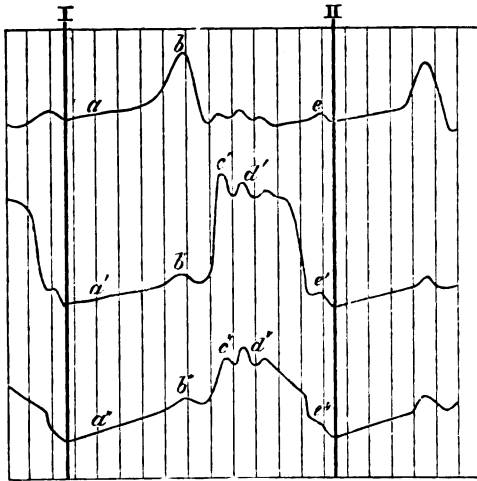

FIG. 22. TRACING OF THE VARIATIONS OF PRESSURE IN THE RIGHT AURICLE AND VENTRICLE, AND OF THE CARDIAC IMPULSE, IN THE HORSE. (AFTER MAREY.) (To be read from left to right.)

The upper curve represents the variations of pressure within the auricle, the middle curve the variations of pressure within the ventricle; these two therefore illustrate changes taking place in the interior of the heart. The lower curve represents the variations of pressure transmitted to a lever outside the chest and constituting the cardiac impulse. A complete cardiac cycle, beginning at the close of the ventricular systole, is comprised between the thick vertical lines I and II. The thin vertical lines represent tenths of a second. *a*, the gradual filling of the auricle and ventricle; *b*, the auricular systole; *c*, the ventricular systole; *d*, oscillations of pressure, interpreted by Marey as caused by vibrations of the auriculo-ventricular valves; *e* probably marks the closing of the semilunar valves.

a recording tambour, these authors were enabled to take simultaneous tracings of all the changes of pressure occurring in the two cavities. These results are embodied in Fig. 22, of which the upper curve represents the changes of pressure in the auricle, the middle curve the changes of pressure in the ventricle, and the lower curve the cardiographic tracing of the cardiac impulse. All these curves were taken simultaneously on the same recording surface.

Method. A tube of appropriate curvature is furnished with two small elastic bags, one at the extreme end and the other at such a distance that when the former is within the cavity of the ventricle the latter is in the cavity of the auricle. Each bag (Fig. 23 A) communicates by a separate air-tight tube with an air-tight tambour (Fig. 23 B) on which a lever rests; so that any pressure on either bag is communicated to the cavity of its respective tambour, the lever of which is raised in proportion. The writing

¹ Marey, *Circulation du Sang*.

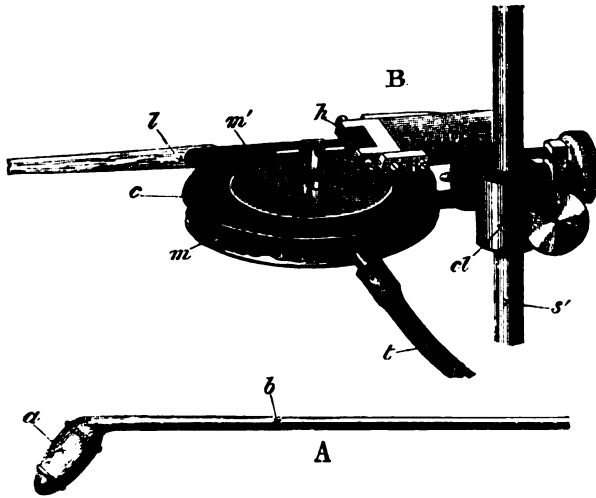

FIG. 23. MAREY'S TAMBOUR, WITH CARDIAC SOUND.

A. A simple cardiac sound such as may be used for exploration of the left ventricle. The portion *a* of the ampulla at the end is of thin india-rubber, stretched over an open framework with metallic supports above and below. The long tube *b* serves to introduce it into the cavity which it is desired to explore.

B. The Tambour. The metal chamber *m* is covered in an air-tight manner with the india-rubber *c*, bearing a thin metal plate *m'* to which is attached the lever *l* moving on the hinge *h*. The whole tambour can be placed by means of the clamp *cl* at any height on the upright *s'*. The india-rubber tube *t* serves to connect the interior of the tambour either with the cavity of the ampulla of *A* or with any other cavity. Supposing that the tube *t* were connected with *b*, any pressure exerted on *a* would cause the roof of the tambour to rise and the point of the lever would be proportionately raised.

points of all three levers are brought to bear on the same recording surface exactly underneath each other. The tube is carefully introduced through the right jugular vein into the right side of the heart until the lower (ventricular) bag is fairly in the cavity of the right ventricle, and consequently the upper (auricular) bag in the cavity of the right auricle. Changes of pressure in either cavity then cause movements of the corresponding lever. When the pressure is increased for instance in the auricle, the auricular lever is raised and describes on the recording surface an ascending curve; when the pressure is taken off the curve descends; and so also with the ventricle.

A complete cardiac cycle is comprised between the vertical lines I. and II. Fig. 22. The recording surface was travelling at such a rate that the intervals between any two of the thin vertical lines corresponds to one-tenth of a second. Hence in this case the whole cardiac cycle occupied about $\frac{1}{10}$ ths of a second. Any point in the cycle might of course be taken as its commencement. In the figure, the cycle is supposed to begin shortly after the end of the ventricular systole, and the beginning of the diastole.

On examining the three curves we see, at *a*, a steady rise of the auricular, accompanied by similar gradual ascents of the ventricular and also of the cardiograph lever. These may be interpreted as indicating that the blood is pouring from the great veins into the auricle, increasing the pressure there, and at the same time passing on into the ventricle, increasing also the internal pressure there, *a'*, and also by distending the ventricle causing it to press somewhat on the chest-wall and thus to raise the cardiograph lever, *a''*. This continues for about $\frac{1}{10}$ ths of a second, and is then followed by the sudden rise of auricular pressure *b* due to the auricular systole, followed by a sudden fall as the blood escapes into the ventricle. The sudden entrance of blood into the ventricle causes a sudden increase of the pressure in the ventricle as indicated by the ventricular lever *b'*, and a sudden increase in the pressure on the chest-wall *b''*. The auricular systole is followed immediately by the sudden strong ventricular systole *c'*, the pressure rising very abruptly. Owing to the presence of the tricuspid valves, this increase of pressure is kept off the auricle altogether; but the chest-wall, as shewn by the tracing at *c'*, feels the sudden increase of the pressure of the ventricle against it. The ventricular pressure lasts for some time, gradually declining, and then suddenly falls. This may be interpreted as indicating that the systole rapidly reaches a maximum, maintains that maximum with a slight decline only for some little time, and then suddenly ceases. The oscillations during the maximum, as seen at *d'*, and also manifest in the auricular curve at *d*, and in the impulse curve at *d''*, are interpreted by Marey as due to vibrations of the tricuspid valves, but their causation is at present by no means clear. At the end of the ventricular systole, the descent of the lever is broken by a slight rise at *e'*, visible also in the auricle at *e*, and even in the impulse curve at *e''*. This is interpreted by Marey as indicating the closure of the semilunar valves. After this slight rise, the ventricular curve and the impulse curve fall to their lowest points, while the auricle is already beginning to fill; and the cardiac cycle begins anew.

It must be remembered that the above curves in the form in which they are given in the diagram can only be used for ascertaining the variations of pressure at different times in the same chamber, or for determining what changes in the one chamber are coincident in point of time with changes in the other. They in no way indicate the *amount of pressure* in the auricle as compared with that in the ventricle. Because in the figure the rise of the curve during the auricular systole is about half that of the ventricle, it does not follow that the pressure caused by the one is half that caused by the other.

Thus of the whole period of a beat, the largest fraction is that of the diastole, or 'passive interval,' *i.e.* of the interval between the end of the ventricular and the commencement of the auricular systole. The next largest is that of the ventricular systole, and the smallest

that of the auricular systole. The duration of the diastole is usually given as $\frac{2}{3}$ of the whole period, that of the whole systole being $\frac{1}{3}$, of which far the greatest part is taken up by the ventricle; but in these measurements the systole is supposed to end with the cessation of the ventricle's contraction and not to include its relaxation. Donders found the ventricular systole, as determined by the time elapsing between the commencement of the first and of the second sounds, and therefore including the relaxation as well as the contraction of the ventricular fibres, to occupy on the average .301 to .327 sec., or 40 to 46 p. c. of the whole period. Landois¹ gives the following measurements, the whole cycle lasting 1.130 sec.

Mean Duration of auricular systole to beginning of ventricular systole177 sec.	} 1.130 .451 sec. = systole of the heart as usually understood. .346 " = systole of ventricle as measured by Donders. .679 " = diastole of the heart as usually understood.
Mean Duration of ventricular contraction192 "	
Mean Duration of maintenance of contraction082 "	
Mean Duration from beginning of relaxation to closure of semilunar valves072 "	
Mean Duration of closure of valves to beginning of pause.....	.200 "	
Mean Duration of remainder of cycle	.407 "	
	1.130	

The proportions however are not fixed, but vary somewhat. Practically speaking, there is no interval between the auricular and ventricular systole, the latter being separated from the former by a fraction of time which is almost inappreciable.

When the actual pressure in the heart of a horse is measured either by a graduation of Marey's instrument, or by introducing an open tube connected with a mercury manometer directly into the cavities of the heart, the pressure during the right auricular systole does not amount to more than 2 or 3 mm. of mercury, while that of the right ventricular systole is about 25 mm., and that of the left ventricle (the tube being introduced through the carotid artery) amounts to about 200 mm.²

Fick³ employing a different method, has arrived at results which in part agree with and in part differ from those of Marey. He introduced, in the right auricle or ventricle through the jugular vein, or into the left ventricle through the carotid artery, a glass tube filled with sodium carbonate solution, open at the end introduced into the heart and connected at the other with a spring manometer (Fig. 24). The variations of pressure occurring in the auricle or ventricle were accordingly directly transmitted to the manometer. He finds that the pressure of the auricle is almost constant during the several cardiac phases. Instead of the pressure rising, as Marey found, during the auricular systole, and becoming negative, i. e. sinking below the pressure of the atmosphere, after the auricular systole,

¹ *Chit. Med. Wiss.* 1866, p. 179.

² Marey, *op. cit.*

³ Ueber die Schwankungen des Blutdruckes in verschiedenen Abschnitten des Gefäßsystems. *Arbeiten a. d. Physiolog. Laborator. d. Würzburger Hochschule*, p. 183.

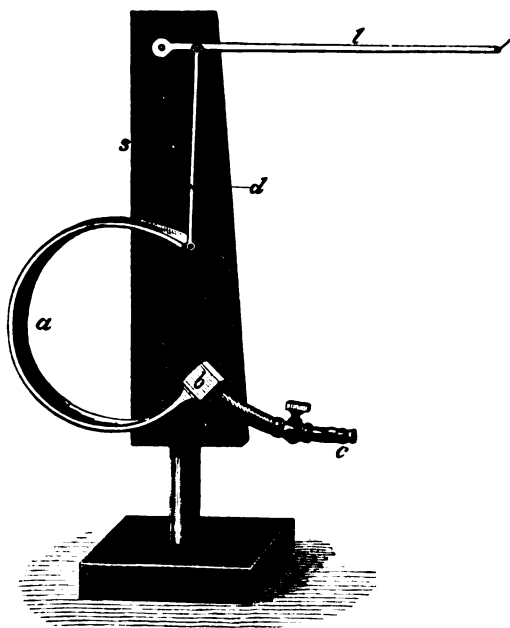

FIG. 24. DIAGRAM ILLUSTRATING FICK'S SPRING MANOMETER.

This consists essentially of a hollow flattened german-silver tube *a*, curved in the form of an incomplete circle. The lower open end *b*, firmly fastened to the stand *s*, is connected with a tube *c*, bearing a stop-cock. To the upper closed end *d* is attached a light upright rod connected with the writing lever *l*.

Through the tube *c* the hollow curved spring is filled with alcohol, and the stop-cock closed. The tube *c* is then connected with the artery by means of a non-elastic flexible (lead) tube filled with sodium carbonate solution. On opening the stop-cock the variations of pressure of the blood in the artery are communicated to the fluid in the hollow curved spring; at each increase of pressure the spring expands, and the movements of the free end *d* are transferred to the writing lever *l*. The instrument as generally sent out also bears an arrangement (not shown in the diagram), by which the point of the lever describes a straight instead of a curved line. The spring manometer is exceedingly useful where it is desirable to investigate closely the variations in the form of the pressure-curve. In order to measure the amount of variation, the instrument must be experimentally graduated.

according to Fick, it does not, apart from respiratory effects, vary more than about 2 mm. of mercury from the base line of the pressure of the atmosphere (Fig. 25 A), being for the most part slightly below it; and the elevations which are seen are coincident, not with its own systole, but that of the ventricle. This result is quite in accordance with Fick's view of the proper function of the auricles, viz. to keep the pressure constant at the entrance of the great veins into the heart. Were the right auricle absent there could be no flow from the veins into the heart during the ventricular systole, and consequently an arrest for the time being of the flow along the veins. By the presence of the auricle this evil is avoided. During the ventricular systole, the auricle acts as a reservoir, its walls being relaxed in diastole, and becoming expanded in proportion as

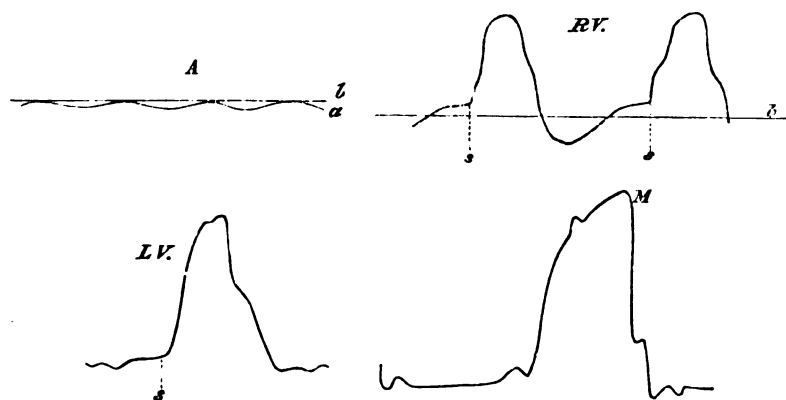

FIG. 25. CURVES ILLUSTRATING THE VARIATIONS OF PRESSURE IN THE CAVITIES OF THE HEART ACCORDING TO FICK. (To be read from left to right.)

- A.* The pressure in the right auricle. *b*, the base line or line of pressure of one atmosphere. The curve of the auricular pressure is here for the most part slightly negative, rising to the base line during the ventricular systole.
- R. V.* The pressure in the right ventricle. *b*, the base line, as before. *s*, the commencement of the systole. The pressure is seen to become negative during the diastole.
- L. V.* The pressure in the left ventricle. The base line is not shown, but it occupies about the same position as in *R. V.* *s*, the commencement of the systole.

The curve *M* is a copy of one of Marey's curves of the left ventricle (differing somewhat from that given in Fig. 22), introduced for the sake of comparison.

more and more blood flows into the auricle from the veins. During the ventricular diastole, the extra room thereby afforded for the blood would tend to diminish the pressure in the auricle; but this is the time when the auricle contracts, and, by diminishing the capacity of its cavity in proportion as its contents escape into the ventricle, maintains the pressure in the auricular cavity fairly equable. According to this view however the auricular systole ought immediately to succeed the ventricular systole; which it does not. This fairly constant pressure in the auricle Fick found to be influenced by the respiratory movements, especially when the breathing was laboured, rising considerably above the base line (of atmospheric pressure) in expiration and sinking sometimes as much as 10 mm. below during inspiration. The curves (Fig. 25, *R. V.* *L. V.*) which he obtained from the right and left ventricles, resemble very closely those of Marey; the pressure during the systole being in the dog on the right side from 20—40 mm., on the left side about 140 mm. He found that on both sides the pressure became negative, falling slightly below the base line, immediately after the systole, rather more on the right side than on the left. Marey found the same negative pressure immediately after the systole to be greater on the left than on the right. Fick arrived at the puzzling result, which he says cannot be due to sluggishness of the manometer, that with a quick pulse the maximum pressure in the left ventricle may be as much as 24 mm. below that of the aorta. Though Fick's results have been corroborated by

Gradle¹, Marey² insists that they are due to a faultiness of the manometer. The more normal condition occurring with an ordinary rapidity of pulse, is shewn in Fig. 26.

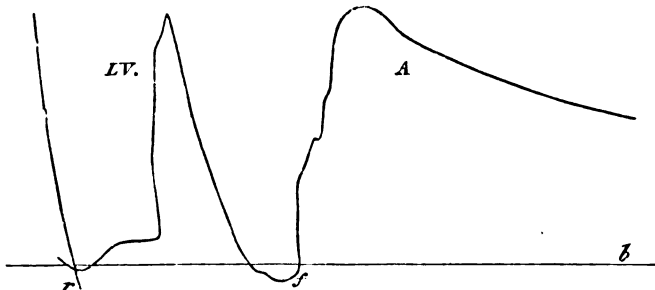

FIG. 26. CURVE ILLUSTRATING THE PRESSURE IN LEFT VENTRICLE AS COMPARED WITH THAT IN AORTA. (To be read from left to right.)

At *f* the tube was withdrawn from the cavity of the ventricle through the semilunar valves into the aorta. *L. V.*, the pressure in the ventricle. *A*, the pressure in the aorta. The more gradual fall of the pressure in the aorta is very marked. *b* the base line. The curve *L. V.* differs slightly from *L. V.* in Fig. 25, because in the former the aberration caused by the curvilinear movement of the writing lever (indicated by the line *r*) has not been corrected.

The Mechanism of the Valves.

The auriculo-ventricular valves present no difficulty. As the blood is being driven by the auricular systole into the ventricle, a reflux current is set up, by which the blood, passing along the sides of the ventricle, gets between them and the flaps of the valve (whether tricuspid or mitral). As the pressure of the auricular systole diminishes, the same reflux current floats the flaps up, until at the extreme end of the systole they meet, and thus the orifice is at once and firmly closed, at the very beginning of the ventricular beat. The increasing intraventricular pressure serves only to render the valve more and more tense, and in consequence more secure, the chordæ tendinæ and the contraction of the papillary muscles (simultaneous with that of the rest of the ventricular walls) preventing the valve from being inverted into the auricle, and indeed keeping the plane of the valvular sheet convex to the ventricular cavity, by which means the complete emptying of the ventricle is more fully effected. Since the same papillary muscle is in many cases connected by chordæ with the adjacent edges of two flaps, its contraction also serves to keep these flaps in more complete apposition. Moreover the extreme borders of the valves, outside the attachments of the chordæ, are excessively thin, so that when the valve is closed, these thin portions are pressed flat together back to back; hence while the

¹ *Wiener Med. Jahrb.* 1876, p. 401.

² *Trav. du Laborat.* II. 319.

tougher central parts of the valves bear the force of the ventricular systole, the apposed thin membranous edges, pressed together by the blood, more completely secure the closure of the orifice.

The semilunar valves are, during the ventricular systole, pressed outwards towards the arterial walls, and thus offer no obstacle to the escape of blood from the cavities of the ventricles. As the ventricular systole diminishes, a reflux current partially fills the pockets, and tends to carry their free margins towards the middle of the tube. Upon the sudden close of the systole, the elastic rebound of the arterial walls causes a sudden current backwards, which, filling and distending the pockets, causes their free margins to come into complete and firm contact, and thus entirely blocks the way. The corpora Arantii meet in the centre, and the thin membranous festoons or lunulæ are brought into exact apposition. As in the tricuspid valves, so here, while the pressure of the blood is borne by the tougher bodies of the several valves, each two thin adjacent lunulæ, pressed together by the blood acting on both sides of them, are kept in complete contact, without any strain being put upon them; in this way the orifice is closed in a most efficient manner.

An ingenious view has been put forward by Brücke¹ concerning the action of the semilunar valves. He maintains that during the ventricular systole, the flaps are pressed back flat against the arterial walls, and in the case of the aorta completely cover up the orifices of the coronary arteries; hence the flow of blood from the aorta into the coronary arteries can take place only during the ventricular diastole or at the very beginning of the systole, and not at all during the systole itself. The object of this, he argues, is twofold. In the first place, the muscular tissue of the ventricle is not burdened with blood at the moment that it is undergoing contraction, but receives its nutritive supply during the phase of relaxation; hence the whole force of the contraction of the ventricular fibres is spent on the contents of the cavity, and none is wasted in compression of the intra-muscular blood-vessels. In the second place, the effect of the flow, at the close of the systole, into the previously emptied coronary arteries, is to unfold, so to speak, the collapsed cavities of the ventricles very much in the same way as the collapsed cavity of a double-walled ball may be reinstated by the forcible injection of fluid into the space between the two walls. Through this particular behaviour of the valves, in fact, the heart, as an after-effect of the systole, dilates its own ventricles; hence the mechanism has been called by Brücke a 'self-regulating mechanism.'

Brücke's view has however been much disputed. In the first place, we know that the flow of blood from an ordinary skeletal muscle, though it may suffer a brief initial check (probably from compression of the larger veins), is increased and not diminished by a tetanic contraction of the muscle, the increase being visible while the contraction is still at its height². Corresponding to this lasting increased flow from the veins there must be an increased flow into the arteries. And in certain dispositions of the

¹ *Wien. Sitz.-Berichte*, 1854; and *Der Verschluss d. Kranzschlagadern*.

² Gaskell, *Ludwig's Arbeiten*, 1876; and *Journ. Anat. and Phys.*, xi. 360.

blood-vessels and muscular fibres (as when a vessel is surrounded by fibres running lengthways parallel to itself), the increased thickening of the fibres will tend not to compress but to dilate the vessel. The advantage to the muscular tissue therefore of the closure of the coronary arteries seems at least doubtful. In the second place, it has been urged that, in point of fact, the mouths of the coronary arteries are not covered by the valves. Brücke replies that they may appear uncovered during dissection after death, but are actually covered during life. He moreover brings forward an experiment on a pig's heart removed from the body, in which a stream of water sent through the pulmonary veins and auricle into the left ventricle issues through the open aorta, without a drop of it appearing at the cut end of an opened coronary artery, if the aorta be maintained in a proper position, and all vibration and jar be avoided; and argues that it is the closure of the orifices by the valves which prevents the flow, because any shake sufficient to develop a backward current in the aorta and thus to lift up the valves, at once gives rise to a flow. If however, as has been stated, the experiment will succeed equally well in the absence of the valves, and will not succeed if the free exit of fluid from the end of the aorta be hindered though the valves be intact, the absence of a flow through the coronary artery must be due to a deficiency of pressure in the aorta and not to any action of the valves. The undoubted fact that blood flows from a wounded coronary artery in jerks corresponding to the systole and not to the diastole, Brücke meets with the observation that the coronary arteries must share just previous to the closure of the valves in that increased pressure in the aorta which is the cause of the closure of the valves, and that the higher pressure thus gained at the beginning of the systole is maintained during the systole by the obstruction to the outward flow arising from the contracting fibres compressing the small vessels; while the empty condition of the small branches of the coronary arteries and of the veins at the commencement of the diastole, must diminish the pressure in the main coronary arteries themselves during diastole, and so prevent a diastolic spurt from a wound in them. This however is hardly satisfactory, since as regards the systole, as has been urged above, an obstruction of the flow from compression by the muscular fibres is at least doubtful, and as regards the diastole the supposed empty condition of the coronary vessels can produce an effect only at the very beginning of the diastole. On the other hand, Ceradini¹, who observed the condition of the valves in an excised heart by looking down through a wide glass tube inserted into the aorta, is of opinion that during the systole the valves are not applied close to the arterial wall, but float in an intermediate position of equilibrium, maintained by reflux currents, their orifice taking on the form of an equilateral triangle with curved sides. The same reflux currents gradually (but of course rapidly) close the orifice as the force of the systole diminishes, and the effect of the elastic rebound is simply to render the closure tense and firm. Thus, argues Ceradini, no regurgitation of fluid from the aorta into the ventricle at the end of the systole and the beginning of the diastole is possible, and a hurtful waste, which on Brücke's hypothesis seems unavoidable, averted.

The passage of the blood through the heart takes place as follows. The right auricle during its diastole, by the relaxation of its

¹ *Der Mechanismus der halbmondförmigen Herzklappen.* Leipzig, 1872.

muscular fibres, and by the fact that all pressure from the ventricle is removed by the tension of the tricuspid valves, offers but little resistance to the ingress of blood from the veins. On the other hand, the blood in the trunks, both superior and inferior vena cava, is under a certain though low pressure, augmented in the case of the superior vena cava by gravity, and in consequence flows into the empty auricle. At each inspiration, this flow is favoured by the negative pressure in the heart and great vessels caused by the respiratory movements. Before this has gone on very long, the diastole of the ventricle begins, its cavity enlarges, the pressure in that cavity becomes nil or even negative, the flaps of the tricuspid valve fall back, and blood for some little time flows in an unbroken stream from the venæ cavæ into the ventricle. In a short time, however, before much blood has had time to enter the ventricle, the auricle is full, and forthwith its sharp sudden systole takes place. Partly by reason of the onward pressure in the veins, which increases rapidly from the heart towards the capillaries, partly from the presence of valves in the venous trunks and at the mouth of the inferior vena cava, but still more from the fact that the systole begins at the great veins themselves and spreads thence over the auricle, the force of the auricular contraction is spent in driving the blood, not back into the veins, but into the ventricle, where the pressure is still exceedingly low.

Whether there is any backward flow at all into veins, or even an interruption to the forward flow, or whether by the progressive character of the systole the flow of blood continues, so to speak, to follow up the systole without break so that the stream from the veins into the auricle is really continuous, is at present doubtful; though a slight positive wave of pressure synchronous with the auricular systole, travelling backward along the veins, has been observed at least in cases where the heart is beating vigorously.

The ventricle thus being filled, the play of the tricuspid valves described above comes into action, the auricular systole is followed by that of the ventricle, and the pressure within the ventricle, cut off from the auricle by the tricuspid valves, is brought to bear entirely on the conus arteriosus and the pulmonary semilunar valves. As soon as by the rapidly increasing force of the ventricular contraction, the pressure within the ventricle becomes greater than that in the pulmonary artery, the semilunar valves open, and the still increasing systole discharges the contents of the ventricle into that vessel. But as the systole passes off, the pressure in the artery becomes greater than that in the cavity of the ventricle, and a rebound of the blood takes place. The first act of this rebound however is, as we have seen, firmly to close the semilunar valves, and thus to shut off the over-distended artery from the now empty, or nearly empty, ventricle.

During the whole of this time the left side has with still greater energy been executing the same manœuvre. At the same time that

the *venæ cavæ* are filling the right auricle, the pulmonary veins are filling the left auricle. At the same time that the right auricle is contracting, the left auricle is contracting too. The systole of the left ventricle is synchronous with that of the right ventricle, but executed with greater force; and the flow of blood is guided on the left side by the mitral and aortic valves in the same way that it is on the right by the tricuspid valves and those of the pulmonary artery.

The Sounds of the Heart.

When the ear is applied to the chest, either directly or by means of a stethoscope, two sounds are heard, the first a comparatively long dull booming sound, the second a short sharp sudden one. Between the first and second sounds, the interval of time is very short, but between the second and the succeeding first sound there is a distinct pause. The sounds have been likened to the pronunciation of the syllables, *lubb, düp*, so that the cardiac cycle as far as the sounds are concerned, might be represented by:—*lubb, düp, pause*. The relative duration of the sounds, and of the pause, as well as their relations in point of time to the changes taking place in the heart, are shewn in the following diagram. Fig. 27.

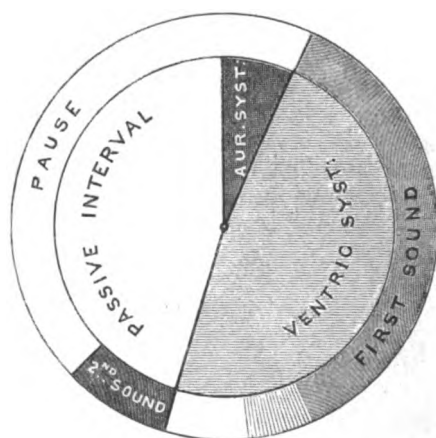

FIG. 27. DIAGRAMMATIC REPRESENTATION OF THE MOVEMENTS AND SOUNDS OF THE HEART DURING A CARDIAC PERIOD. (AFTER DR SHEARPEY.)

The ventricular systole, which is here used to denote the action of the ventricle up to the closure of the semilunar valves, is represented as occupying about 45 p. c., and the two sounds together as rather more than half, of the whole period; but the diagram is intended to shew merely the general relations of the various events, and not to serve as a means of measurement.

The second short sharp sound presents no difficulties. It is coincident in point of time with the closure of the semilunar valves,

and is heard to the best advantage over the second right costal cartilage close to its junction with the sternum, *i.e.* at the point where the aortic arch comes nearest to the surface. Its characters are such as would belong to a sound generated by the sudden tension of valves like the semilunar valves. It is obscured and altered, replaced by 'murmurs' when the semilunar valves are affected by disease, the alteration being most manifest to the ear at the above-mentioned spot when the aortic valves are affected. When the aortic valves are hooked up by means of a wire introduced down the arteries, the second sound is obliterated and replaced by a murmur. These facts prove that the second sound is due to the sudden tension of the aortic (and pulmonary) semilunar valves.

The first sound, longer, duller, and of a more 'booming' character than the second, heard with greatest distinctness at the spot where the cardiac impulse is felt, presents many difficulties in the way of a complete explanation. It is heard distinctly when the chest-walls are removed. The cardiac impulse therefore can have little or nothing to do with it. In point of time, and in the position in which it may be heard to the greatest advantage (at the spot of the cardiac impulse where the ventricles come nearest to the surface), it corresponds to the closure of the auriculo-ventricular valves. In point of character it is not such a sound as one would expect from the vibration of membranous structures, but has, on the contrary, many of the characters of a muscular sound. In favour of its being a valvular sound, may be urged the fact that it is obscured, altered, replaced by murmurs, when the tricuspid or mitral valves are diseased; and Halford¹ found that clamping the great veins stopped the sound though the beat continued. On the other hand, Ludwig and Dogiel² heard the sound distinctly in a bloodless dog's heart, in which there was no fluid to render the valves tense and set them vibrating. But there is a great difficulty in regarding it as a muscular sound, for a muscular sound is the result of a tetanic contraction, the height of the note produced varying with the number per second of the simple contractions which go to make up the tetanus. A simple contraction or spasm cannot possibly produce a musical sound, such as is the cardiac sound. The beat of the heart is a comparatively slow long-continued single spasm, and not a tetanic contraction. In its long latent period, and in all its characters, the heart's beat bears the stamp of being a single spasm. If so it cannot give rise to a note.

When the rheoscopic muscle-nerve preparation (p. 54) is placed over the heart, each beat of the heart (ventricle or auricle) is followed by a single spasm, not by tetanus, of the rheoscopic muscle. By properly disposing the nerve of the preparation a contraction corresponding to the systole of the auricle followed rapidly by a second corresponding to the

¹ *Action and Sounds of the Heart.* London, 1860.

² *Ludwig's Arbeiten*, Jahrg. 1868.

systole of the ventricle may be obtained, but in each case the contraction in the leg is simple and not tetanic. This result is consistent with the view that the systole is a simple spasm, but cannot be regarded as a proof that it is such. For it is not every tetanus in a muscle which will give a secondary tetanus in the rheoscopic muscle. When the tetanus in a muscle is induced by the ordinary interrupted current applied directly to the nerve of the muscle, the tetanus in the rheoscopic muscle appears without difficulty, but where the tetanus is produced by a constant current, the so-called breaking or making tetanus (p. 59), the rheoscopic muscle responds by a single (initial) spasm instead of a tetanus. The pronounced tetanus of strychnia similarly gives rise to a simple initial spasm and not to a tetanus of the rheoscopic muscle, and the same feature is characteristic of the natural respiratory contractions of the diaphragm and probably of all voluntary contractions¹.

Moreover, in cases of hypertrophy, where the muscular element and action is increased, the sound, so far from being increased, is impaired. Hence, the first sound, whether it be regarded as the result of the vibration of the auriculo-ventricular valves, acted upon by, and in turn acting on, columns of blood, or as a muscular sound, presents great difficulties. No other cause, in the least satisfactory, has been suggested; and the difficulties are rather increased than met by supposing that the sound is at once both valvular and muscular in origin.

The Work done.

We can measure with exactness the intraventricular pressure, the length of each systole, and the number of times the systole is repeated in a given period, but perhaps the most important factor of all in the determination of the work of the vascular mechanism, the quantity ejected from the ventricle into the aorta at each systole, cannot be accurately determined; we are obliged to fall back on calculations having many sources of error. The mean result of these calculations gives about 180 grms. (6 oz.) as the quantity of blood which is driven from each ventricle at each systole in a full-grown man of average size and weight. It is evident that exactly the same quantity must issue at a beat from each ventricle; for if the right ventricle at each beat gave out rather less than the left, after a certain number of beats the whole of the blood would be gathered in the systemic circulation. Similarly, if the left ventricle gave out less than the right, all the blood would soon be crowded into the lungs. The fact that the pressure in the right ventricle is so much less than that in the left (30 or 40 mm. as compared with 200 mm. of mercury), is due, not to differences in the quantity of blood in the cavities, but to the fact that the peripheral resistance which has to be overcome in the lungs is so much less than that in the rest of the body.

¹ Hering u. Friedrich, *Wien. Sitzungs-Berichte*, LXXII. (1875).

Various methods have been adopted for calculating the average amount of blood ejected at each ventricular systole. It has been calculated from the capacity of the recently removed and as yet not rigid ventricle, filled with blood under a pressure equal to the calculated average pressure in the ventricle. This method of course presupposes that the whole contents of the ventricle are ejected at each systole. Volkmann¹ measured the sectional area of the aorta, and taking an average velocity of the blood in the aorta (a very uncertain datum), calculated the quantity of blood which must pass through the sectional area in a given time. The number of beats in that time then gave him the quantity flowing through the area and consequently ejected from the heart at each beat. The mean of many experiments on different animals came out .0025 p. c. of the body weight, which in a man of 75 kilos would be 187.5 grms. Vierordt measured the mean velocity and the sectional area in the carotid, and thence, from a measurement of the sectional area of the aorta, and from a calculation of the blood's mean velocity in it, based on the supposition that the mean velocity in an artery was inversely as its sectional area, arrived at the quantity flowing through the aortic sectional area in a given time, and thus at the quantity passing at each beat. Both these calculations are vitiated by the fact that the variations of velocity in the aorta are so great, that any mean has really but little positive value.

Fick² by means of calculations based partly on the data gained by observing the increase of the volume of the whole arm at each cardiac systole, arrived at results much less than either of the above. In one case he estimated the quantity ejected from the heart at each beat at 53 grm., and in a second case at 77 grm.

It must be remembered that though it is of advantage to speak of an average quantity ejected at each stroke, it is more than probable that that quantity may vary within very wide limits. Taking, however, 180 grms. as the quantity ejected at each stroke at a pressure of 250 mm.³ of mercury, which is equivalent to 3.21 metres of blood, this means that the left ventricle is capable at its systole of lifting 180 grms. 3.21 m. high, *i.e.* it does 578 gram-metres of work at each beat. Supposing the heart to beat 72 times a minute, this would give for the day's work of the left ventricle, nearly 60,000 kilogram-metres; calculating the work of the right ventricle at one-fourth that of the left, the work of the whole heart would amount to 75,000 kilogram-metres. A calculation of more practical value is the following. Taking the quantity of blood as $\frac{1}{3}$ of the body weight, the blood of a man weighing 75 kilos would be about 5,760 grms. If 180 grms. left the ventricle at each beat, a quantity equivalent to the whole blood would pass through the heart in 32 beats, *i.e.* in less than half a minute.

¹ *Hämodynamik*, p. 206.

² *Untersuch. Physiol. Lab. Zürich. Hochschule*, Hft. 1. p. 51 (1869).

³ A high estimate is purposely taken here.

Variations in the Heart's beat. †

These are for the most part in reality vital phenomena, *i.e.* brought about by events depending on changes in the vital properties of some or other of the tissues of the body. It will be convenient, however, briefly to review them here, though the discussion of their causation must be deferred to its appropriate place.

The **frequency** of the heart, *i.e.* the number of beats in any given time, may vary. The average rate of the human pulse or heart-beat is 72 a minute. It is quicker in children than in adults, but quickens again a little in advanced age. It is quicker in the adult female than in the adult male, in persons of short stature than in tall people. It is increased by exertion, and thus is quicker in a standing than in a sitting, and in a sitting than in a lying posture. It is quickened by meals, and while varying thus from time to time during the day, is on the whole quicker in the evening than in early morning. It is said to be on the whole quicker in summer than in winter. Even independently of muscular exertion it seems to be quickened by great altitudes. Its rate is profoundly influenced by mental conditions.

The **length of the systole** may vary, though as a general and broad rule it may be stated that a frequent differs from an infrequent pulse chiefly by the length of the diastole.

Donders found the length of the systole as measured by the interval between the first and second sounds to be for ordinary pulses remarkably constant in different persons, varying not more than from .327 to .301 sec., and being therefore relatively to the whole cardiac period less in slow than in quick pulses. Garrod¹ deduces from a number of sphygmographic tracings the law, which Thurston² finds to hold good in pulses varying from 42 to 128, that the length of interval between the commencement of the primary and that of the dicrotic rise in the curve of the radial pulse (and this he takes as a measurement of the cardiac systole, see the following section) is constant in different individuals for the same pulse-rate, and varies as the cube root of the pulse-rate; but other observers have failed to verify his results, and the meaning of the interval in the pulse-curve is not free from doubt.

The **force of the beat** may vary; the ventricular systole may be weak or strong.

When the rate of beat is suddenly increased there is a tendency for the individual beats to be diminished in force, and on the other hand to be increased in force when the rate is diminished. But there is no necessary connection between rate and strength; both a frequent and an infrequent pulse may be either weak or strong.

The **character of the beat** may vary; the systole may be sudden and sharp, rapidly reaching a maximum and rapidly declining, or

¹ *Proc. Roy. Soc.*, Vol. 18, p. 351.

² *Journ. Anat. and Phys.*, x. p. 494.

slow and lengthened, reaching its maximum only after some time and declining very gradually; the latter being the slow pulse (*pulsus tardus*) as distinguished from the infrequent pulse (*pulsus rarus*). The pulse is also sometimes spoken of as being slapping, and sometimes as heaving.

The **rhythm** may be *intermittent* or *irregular*. Thus in an intermittent pulse, a beat may be so to speak dropped—the hiatus occurring either regularly or irregularly. In an irregular rhythm succeeding beats may differ in length, force or character.

SEC. 3. THE PULSE.

When the finger is placed on an artery, such as the radial, an intermittent pressure on the finger, coming and going with the beat of the heart, is felt. When a light lever such as that of the sphygmograph is placed on the artery, the lever is raised at each beat, falling between. The pressure on the finger, and the raising of the lever, are expressions of the expansion of the elastic artery, of the temporary additional distension which the artery undergoes at each systole of the ventricle. This intermittent expansion is called the pulse; it corresponds exactly to the intermittent outflow of blood from a severed artery, being present in the arteries only, and in a normal state of things, absent from the veins and capillaries. (The so-called venous pulse, which is something entirely different, will be considered subsequently.) The expansion is frequently visible to the eye, and in some cases, as where an artery has a bend, may cause a certain amount of locomotion of the vessel.

All the more important phenomena of the pulse may be witnessed on an artificial scheme.

If two levers be placed on the arterial tubes of an artificial¹ scheme, one near to the pump, and the other near to the peripheral resistance, with a considerable length of tubing between them, and both levers be made to write on a recording surface, one immediately below the other, so that their curves can be more easily compared, the following facts may be observed, when the pump is set to work regularly.

1. With each stroke of the pump, each lever (Fig. 28, I. and II.) rises to a maximum, *1a*, *2a*, and then falls again, thus describing a curve,—the pulse-curve. This shews that the expansion of the tubing passes the point on which the lever rests in the form of a wave. At one moment the lever is quiet: the tube beneath it is simply distended to the normal permanent amount indicative of the mean arterial pressure; at the next moment the pulse expansion reaches the lever, and the lever

¹ By this is simply meant a system of tubes, along which fluid can be driven by a pump worked at regular intervals. In the course of the tubes a (variable) resistance is introduced in imitation of the capillary resistance. The tubes on the proximal side of the resistance consequently represent arteries; those on the distal side, veins.

begins to rise, and continues to do so until the top of the wave reaches it, after which it falls again until it is once more at rest, the wave having completely passed by.

The rise of each lever is somewhat sudden, but the fall is more gradual, and is generally marked with some irregularities. The suddenness of the rise is due to the suddenness with which the sharp stroke of the pump expands the tube; the fall is more gradual because the elastic reaction of the walls, whereby the tube returns to its former condition after the expanding power of the pump has ceased, is gradual in its action.

2. The size and form of each curve depends in part on the amount of pressure exerted by the levers on the tube. If the levers only just touch the tube in its expanded state, the rise in each will be insignificant. If on the other hand they be pressed down too firmly, the tube beneath will not be able to expand as it otherwise would, and the rise of the levers will be proportionately diminished. There is a certain pressure, depending on the expansive power of the tubing, at which the tracings are best marked.

3. If the points of the two levers be placed exactly one under the other on the recording surface, it is obvious that, the levers being alike except for their position on the tube, any difference in time between the movements of the two levers will be shewn by an interval between the beginnings of the curves they describe, if the recording surface be made to travel sufficiently rapidly.

If the movements of the two levers be thus compared, it will be seen that the far lever (Fig. 28, II.) commences later than the near one (Fig. 28, I.); the farther apart the two levers are, the greater is the interval in time between their curves. Compare the series I. to VI. (Fig. 28). This means that the wave of expansion, the pulse-wave, takes some time to travel along the tube. By exact measurement it would similarly be found that the rise of the near lever began some fraction of a second after the stroke of the pump.

This travelling of the expansion-wave, or pulse-wave, must be carefully distinguished from the propagation of the *shock* given by the stroke of the pump. When a long glass (or other rigid) tube filled with water is smartly tapped at one end, the blow is immediately felt as a shock at the other end. The transmission of this shock, if carefully measured, would be found to be exceedingly rapid; compared with the pulse-wave now under consideration, it would be practically instantaneous. When fluid is driven by the strokes of a pump along a rigid tube, a similar shock, travelling equally rapidly, may be readily felt, and might be registered with a lever. When however the tube along which the fluid is being pumped is elastic, the force of the pump is so much taken up in expanding the tube, that the shock is reduced to very small dimensions. It becomes so slight, that it makes no impression on such levers as are used to register the expansion-wave.

The velocity with which the pulse-wave travels depends chiefly on the amount of rigidity possessed by the tubing. The more extensible (with corresponding elastic reaction) the tube, the slower is the wave; the more rigid the tube becomes, the faster the wave travels. According to Donders the size of the tube has no marked influence. According to Marey the initial velocity, the steepness of

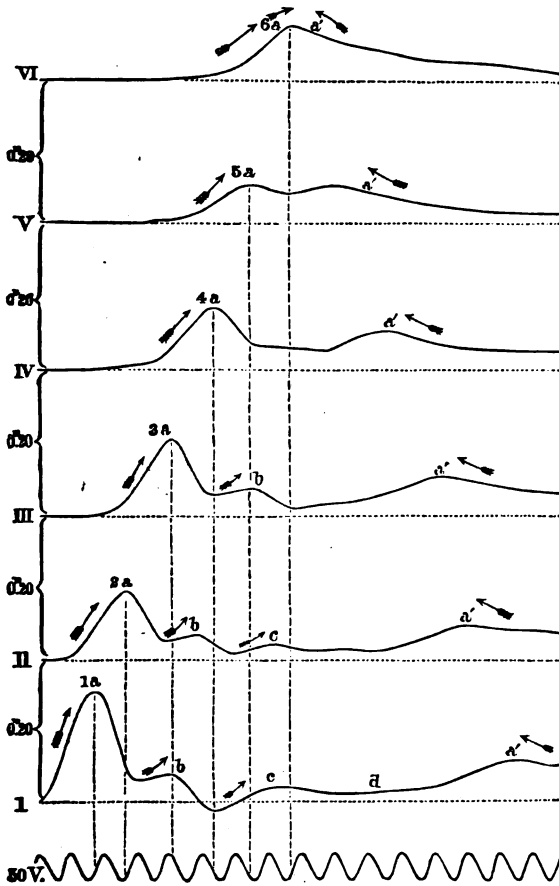

FIG. 28. Pulse-curves described by a series of sphygmographic levers placed at intervals of 20 cm. from each other along an elastic tube into which fluid is forced by the sudden stroke of a pump. The pulse-wave is travelling from left to right, as indicated by the arrows over the primary (a) and secondary (b, c) pulse-waves. The dotted vertical lines drawn from the summit of the several primary waves to the tuning-fork curve below, each complete vibration of which occupies $\frac{1}{50}$ sec., allow the time to be measured, which is taken up by the wave in passing along 20 cm. of the tubing. The waves a' are waves reflected from the closed distal end of the tubing; this is indicated by the direction of the arrows. It will be observed that in the more distant lever VI. the reflected wave, having but a slight distance to travel, becomes fused with the primary wave. (From Marey.)

the wave, has an influence on its rate of progress. In the human body the wave has been estimated to travel at a rate of 9 to 10 metres (Weber 9·240; Garrod 9—10·8, or according to Landois 5 to 6 metres) a second. It probably varies very considerably. According to all observers the velocity of the wave in passing from the groin to the foot is greater than that in passing from the axilla to the wrist (6743 mm. against 5772). This is probably due to the fact that the femoral artery with its branches is more rigid than the axillary.

Since with increase of mean tension, the arteries become more and more rigid, it would be expected that the velocity would increase with the mean tension. According to Weber it does not.

4. When two curves taken at different distances from the pump are compared with each other, the far curve will be found to be shallower, with a less sudden rise, and with a more rounded summit than the near curve: compare 5 *a* with 1 *a*, Fig. 28. In other words, the pulse-wave as it travels onward becomes diminished and flattened out. If a series of levers, otherwise alike, were placed at intervals on a piece of tubing sufficiently long to convert the intermittent stream into a continuous flow, the pulse-wave might be observed to gradually flatten out and grow less until it ceased to be visible.

Care must be taken not to confound the progression of the pulse-wave with the progression of the fluid itself. The pulse-wave travels over the moving blood somewhat as a rapidly moving natural wave travels along a sluggishly flowing river, the velocity of the pulse-wave being 9 metres per sec., while that of the current of blood is not more than ·5 metre per sec. even in the large arteries, and diminishes rapidly in the smaller ones.

Taking the duration of the systole of the ventricle as $\frac{4}{10}$ of a second, it is evident that the pulse-wave started by any one systole, if it travels at 9 m. per sec., will *before the end of the systole* have reached a point, $\frac{4}{10}$ of 9 m. = 3·6 m. distant from the ventricle. In other words, the wave-length of the pulse-wave is much longer than the whole of the arterial system, so that the beginning of each wave has become lost in the small arteries and capillaries some time before the end of it has finally left the ventricle.

The general causation of the pulse may then be summed up somewhat as follows. The systole of the ventricle drives a quantity of fluid into the already full aorta. The portion of the aorta next to the heart expands to receive it, thus giving rise to the sudden upstroke of the pulse-curve. The systole over, the aortic walls, by virtue of their elasticity, tend to return to their former calibre, and the aortic valves being closed, this elastic force is spent in driving the blood onward. The elastic recoil being slower than the initial expansion, the downstroke of the pulse-curve is more gradual than the upstroke. Of this portion of the aorta, which actually receives the blood ejected from the heart, the part immediately adjacent to the semilunar valves begins to expand first, and the expansion travels thence on to the end of

FIG. 29. a.



FIG. 29. b.



. SPHYGMOGRAPH TRACING FROM THE ASCENDING AORTA (Aneurismal dilatation). Amplified 40 times.

In this and the succeeding pulse-curves, B indicates the predicrotic wave, C the dicrotic wave¹.

N.B. These curves are introduced to shew the *general* features of the pulse-curve in various arteries. Not being on the same scale or taken under the same circumstances, they are not intended for careful comparison.

b. FROM CAROTID ARTERY OF A HEALTHY MAN (æt. 26), amplified 30 times.

FIG. 29. c.

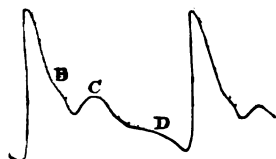

FIG. 29. d.



c. FROM THE RADIAL ARTERY OF THE SAME PERSON AS 29. b. Pressure 4 oz. Amplified 90 times, as are also the succeeding curves.

(Where not otherwise indicated this is the amplification of all the pulse-curves.)

d. FROM RADIAL ARTERY OF A HEALTHY MAN LESS ATHLETIC THAN 29. c. Pressure 3 oz.

FIG. 29. e.



e. FROM THE DORSALIS PEDIS OF THE SAME PERSON AS b. AND c. Pressure 3 oz.

FIG. 29. f.

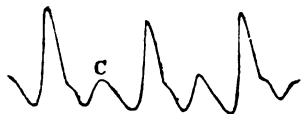
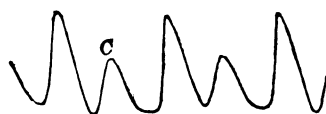

FIG. 29. g.



f. TRACING OF PULSE FULLY DICROTIC: PREDICROTIC WAVE ALSO SHEWN. Pressure 3 oz. (? Typhoid Fever.)

g. PULSE FULLY DICROTIC, AND DICROTIC WAVE VERY LARGE. Pressure 1 oz. (Typhoid Fever.)

¹ For this and the succeeding pulse-curves I am indebted to the great kindness of Dr Galabin.

Fig. 29. h.



Fig. 29. k.



h. PULSE WITH VERY LARGE PREDICROTIC WAVE. Pressure 4 oz. (Acute Albuminuria.)

k. HYPERDICROTIC PULSE, THE DICROTIC WAVE BECOMING LOST ON THE SUCCEEDING BEAT. Pressure $\frac{1}{2}$ oz. After hæmorrhage in typhoid fever.

this portion. In the same way it travels on from this portion through all the succeeding portions of the arterial system. For the total expansion required to make room for the new quantity of blood cannot be provided by that portion alone of the aorta into which the blood is actually received; it is supplied by the whole arterial system; the old quantity of blood which is replaced by the new in this portion has to find room for itself in the rest of the arterial space. As the expansion travels onward, however, the *increase* of pressure which each portion transmits to the succeeding portion will be less than that which it received from the preceding portion, for the whole increase of pressure due to the systole of the ventricle has to be distributed over the whole of the arterial system, and a fraction of it must therefore be left behind at each stage of its progress; that is to say, the expansion is continually growing less, as the pulse travels from the heart to the capillaries; hence the diminished height of the pulse-curve in the more distant arteries, and its disappearance in the capillaries.

Secondary Waves. In the natural pulse-curve the fundamental wave is seen to be marked by two or more *secondary* waves imposed upon it. These secondary waves vary much according to circumstances, and are consequently of interest, as throwing light on the condition of the vascular system.

In an artificial scheme, two kinds of secondary waves are seen.

1. Waves of oscillation. When a moderate quantity of fluid is injected into the tube at each stroke, one, two, or more secondary waves are seen to follow the primary one. They are the more marked, the more sudden the stroke, the more extensible (and elastic) the tubing, and the less the pressure in it. When the pump is a pump without valves, they form a regular decreasing series, succeeding the primary wave, and travelling at the same velocity as it (Fig. 28, I. II. III. b, c), but becoming sooner obliterated.

These waves are due to the inertia of the elastic walls, and of the contained fluid, and so correspond to the secondary oscillations of the mercury in a manometer. If the tube be filled with air instead of

water, they are almost entirely absent. If mercury be employed instead of water, they become very conspicuous.

When the quantity of fluid injected is large compared with the calibre of the tubing, the secondary waves may be seen on the descending line of the primary wave.

2. Reflected waves. When the tube of the artificial scheme bearing two levers is blocked just beyond the far lever, the primary wave is seen to be accompanied by a second wave, which at the far lever is seen close to, and often fused into, the primary wave (Fig. 28, VI. α'), but at the near lever is at some distance from it (Fig. 28, I. α'), being the farther from it, the longer the interval between the lever and the block in the tube. This second wave is evidently the primary wave reflected at the block and travelling backwards towards the pump. It thus of course passes the far lever before the near one. The secondary waves of oscillation may be similarly reflected.

Of the secondary waves on the natural pulse-curve, two deserve special notice.

The first and most important is the *dicrotic wave* occurring towards the end of the descent. This is always more or less marked in every pulse; it may be witnessed in the aorta as well as in other arteries (Fig. 29, a to e , C). Sometimes it is so slight as to be hardly discernible. Sometimes it is so marked as to give rise to the appearance of a double pulse, hence the name (Fig. 29, f , g , C).

It is more pointed in the aorta, and in the larger arteries near to the heart, than in the more distant and smaller ones; its summit indeed rounds off more rapidly than does that of the primary one. According to Garrod the interval between the primary and dicrotic rises of the pulse-curve is the same, for any given pulse-rate, in the radial, carotid and posterior tibial arteries, and is therefore probably the same in all arteries. This would shew that the primary and secondary waves travel at the same rate, but Landois and others state that the interval is *longer* in the more distant arteries.

The conditions which favour the development of the dicrotic wave are chiefly:—(1) A sudden sharp ventricular systole. (2) Low tension. Hence dicrotism, not previously well marked, may be brought on at once by diminution of the peripheral resistance by section of the vaso-motor nerves (see Sec. 5). (3) Extensibility (with elastic reaction) of the arterial walls. Hence dicrotism is not well seen in arteries rigid from disease. It may be well marked in one artery and yet very slight in another.

Can we explain the dicrotic wave by shewing that it is either a wave of oscillation, or a reflected wave? That the dicrotic wave is not one reflected from the periphery is clearly shewn by the fact that its distance from the summit of the primary curve is either greater or at least is not regularly less at points of the arteries nearer the capillaries than at points farther from them. This feature indeed

P. 137

shews that the dicrotic wave cannot be in any way a retrograde wave. Again, the more the primary wave is obliterated by the elastic action of the arterial walls, the less should be the reflected wave. Hence dicrotism should diminish with increased extensibility and elastic reaction of the walls. The reverse is the case. Besides, the multitudinous peripheral division of the arterial system would render one large peripherally reflected wave impossible.

On the other hand, all the conditions which favour dicrotism, also favour the occurrence of waves of oscillation. If Fig. 28 I. be compared with Fig. 29 c, the similarity between the wave of oscillation *b* in the one case and the dicrotic wave C in the other is very striking. And we shall probably not go far wrong if we regard the dicrotic wave as in the main a wave of oscillation. There is however evidence that it is not a simple wave of oscillation but one of mixed character, the movement of oscillation being reinforced by a wave of expansion arising from the closure of the aortic valves.

It has been questioned whether waves of oscillation, so manifest in an artificial scheme, do occur to any extent in the arteries of the body, surrounded as these are by tissues which it is argued must tend to act as dampers towards any oscillations due to inertia. But there is no positive evidence of the existence of any such marked damping action, and the remarkable similarity between the tracings obtained by means of exposed tubes and those given by arteries *in situ* is sufficient evidence that in this respect the two behave alike.

That however the dicrotic wave is not simply due to the inertia of the vessels but mixed in character, is shewn by its peculiar features. In simple waves of oscillation, such as those shewn in Fig. 28 I. the first wave of oscillation is the largest, the succeeding ones diminishing in size. Now the dicrotic wave, though undoubtedly the most prominent and in many cases the only observable secondary wave, is not the first secondary wave. It is frequently preceded by the so-called 'predicrotic' wave, which, sometimes (Fig. 29 *h*) of considerable size, is probably also a wave of oscillation. If both these are waves of oscillation, there must be causes at work tending to diminish the first (predicrotic) or to exaggerate the second (dicrotic). And there is an event which readily suggests itself as likely to reinforce the later occurring wave of oscillation, viz. the closure of the aortic valves. At the close of the ventricular systole the pressure in the aorta becomes higher than that in the ventricle itself, and the blood in consequence tends to flow back towards the ventricle. Thus the pressure in the aorta having reached its maximum begins to fall by reason of the backward as well as of the forward flow of the blood. But the closure of the semilunar valves gives a check to this fall. A new wave of expansion starting from the valves is propagated along the aorta and great arteries in sequence to the main primary wave. If we suppose this wave, due to the closure of the aortic valves, to coincide with a wave of oscillation, the prominence of the latter as the dicrotic wave becomes intelligible. This view is supported by the fact that insufficiency in the working of the semilunar valves, the so-called aortic regurgitation, materially interferes with the development of the dicrotic wave. That the wave in question should wholly disappear under

these circumstances, is not to be expected, seeing on the one hand that it is partly a wave of oscillation, and on the other that the valves need not be perfectly closed in order that a secondary wave of expansion may be started at the end of the systole. Such a wave would be originated by any obstacle to the return of blood into the ventricle, and such an obstacle must exist with even the most imperfect valves, or otherwise the circulation would soon come to an end. Garrod¹, arranging a cardiograph registering the cardiac impulse and a sphygmograph registering the radial pulse in such a way that they both wrote on the same recording surface, came to the conclusion that the commencement of the dicrotic rise in the latter corresponded to the point in the former which has been interpreted (Fig. 22, *e'*) as indicating the closure of the aortic valves. This is of course in favour of the view given above.

Dr Burdon Sanderson however denies that the aortic valves act as above explained in producing the dicrotic wave, basing his opinion on the grounds: 1st, That not only may the dicrotic wave be produced, but that a tracing presenting *all* the graphical characters of the radial pulse tracing may be obtained, on an artificial scheme in the absence of any valves corresponding to the aortic valves; 2nd, That the form of a tracing taken at any point of an artificial scheme may be modified at pleasure, and any natural pulse tracing imitated by introducing changes into the distal portion of the scheme while the portion corresponding to the heart remains absolutely the same. The view he takes is somewhat as follows. If *A* be a point in the arterial system and *B* a more distal point, the maximum expansion of *B* will take place somewhat later than the maximum expansion of *A*; when *B* is at its maximum of expansion, *A* will be already declining. As the elastic reaction of *B* sets in it exerts a pressure not only forwards but backwards, so that the decline of expansion in *B* may be regarded as giving rise to a wave of expansion travelling forwards, and to a wave of expansion travelling backwards, the latter reaching *A* during the decline of expansion at that point, and therefore giving rise in *A* to a secondary expansion. This secondary expansion due to the action of the artery at the single point *B* is of course small; but what is true of *B* is also true of all the points distal to *A*. Consequently the artery at the point *A* is, during the decline of its primary expansion, subject to a secondary expansion caused by the elastic reaction of all the arteries in front of, *i.e.* more distal than, itself. The dicrotic wave at any given point is in fact a secondary expansion brought about by the combined elastic reaction of the more distal portions of the system.

The other secondary wave worthy of notice, the so-called predicrotic wave, Fig. 29, *h*, *B*, is much more variable than the dicrotic. Its mode of origin is obscure, but it is probably a wave of oscillation.

Sometimes, though rarely, the dicrotic wave is followed by still another wave, which seems to be simply a wave of oscillation. The pulse is then said to be 'tricrotic.'

In some instances the predicrotic wave appears to be broken into two, and it becomes often very difficult to distinguish those secondary waves of the pulse-curve which are really due to events taking place in the artery

¹ *Proc. Roy. Soc.* xix. p. 318.

from those which have their origin (through inertia in the spring, &c.) in the instrument itself¹. It is worthy of notice that the summit of the curve of intra-ventricular pressure, Fig. 25, LV, is also marked by one or more secondary waves, bearing a considerable resemblance to the predicrotic wave. In the curves obtained by Landois², by allowing the blood from the end of a divided artery to spurt out on to a recording surface, there is no trace of a predicrotic wave though the dicrotic wave is exceedingly well marked.

The pulse then is the expression of two sets of conditions: one pertaining to the heart, and the other to the arterial system. The arterial conditions remaining the same, the characters of the pulse may be modified by changes taking place in the beat of the heart; and again, the beat of the heart remaining the same, the pulse may be modified by changes taking place in the arterial walls. Hence the diagnostic value of the pulse-characters. It must however be remembered that arterial changes may be accompanied by compensating cardiac changes, to such an extent, that the same features of the pulse may obtain under totally diverse conditions, provided that these conditions affect both factors in compensating directions.

II. THE VITAL PHENOMENA OF THE CIRCULATION.

So far the facts with which we have had to deal, with the exception of the heart's beat itself, have been simply physical facts. All the essential phenomena which we have studied may be reproduced on a dead model. Such an unvarying mechanical vascular system would however be useless to a living body whose actions were at all complicated. The prominent feature of a living mechanism is the power of adapting itself to changes in its internal and external circumstances. In such a system as we have sketched above there would be but scanty power of adaptation. The well-constructed machine might work with beautiful regularity; but its regularity would be its destruction. The same quantity of blood would always flow in the same steady stream through each and every tissue and organ, irrespective of local and general wants. The brain and the stomach, whether at work and needing much, or at rest and needing little, would receive their ration of blood, allotted with a pernicious monotony. Just the same amount of blood would pass through the skin on the hottest as on the coldest day. The canon of the life of every part of the whole period of its existence would be furnished by the inborn diameter of its blood-vessels, and by the unvarying motive power of the heart.

Such a rigid system however does not exist in actual living beings. The vascular mechanism in all animals which possess one

¹ Compare Dr Galabin, *Journ. of Anat. and Phys.* Vol. VIII. p. 1, also Vol. X. p. 297.

² Pflüger's *Archiv*, ix. (1874) 71.

is capable of local and general modifications, adapting it to local and general changes of circumstances. These modifications fall into two great classes:

1. Changes in the heart's beat. These, being central, have of course a general effect.

2. Changes in the peripheral resistance, due to variations in the calibre of the minute arteries, brought about by the agency of their contractile muscular coats. These changes may be either local or general.

To these may be added as subsidiary modifying events:

3. Changes in the peripheral resistance of the capillaries due to influences arising out of the as yet obscure relations existing between the blood within and the tissue without the thin permeable capillary walls, and depending on the vital conditions of the one or of the other. Such changes causing an increase of peripheral resistance are seen to a marked degree in inflammation.

4. Changes in the quantity of blood in circulation.

The two first and chief classes of events (and probably the third) are directly under the dominion of the nervous system. It is by means of the nervous system that the heart's beat and the calibre of the minute arteries are brought into relation with each other, and with almost every part of the body. It is by means of the nervous system acting either on the heart, or on the small arteries, or on both, that a change of circumstances affecting either the whole or a part of the body is met by compensating or regulative changes in the flow of blood. It is by means of the nervous system that an organ has a more full supply of blood when at work than when at rest, that the stream of blood through the skin rises and ebbs with the rise and fall of the temperature of the air, that the work of the heart is tempered to meet the strain of overfull arteries, and that the arterial gates open and shut as the force of the central pump waxes and wanes. Each of these vital factors of the circulation must therefore be considered in connection with those parts of the nervous system which are concerned in their action.

SEC. 4. CHANGES IN THE BEAT OF THE HEART.

We have already discussed the more purely mechanical phenomena of the heart. We have therefore in the present section only to inquire into the nature and working of the mechanism by which the beat of the heart is maintained, varied, and regulated.

When a frog's ventricle which has ceased to beat spontaneously is stimulated by touching it with a blunt needle, a beat is frequently called forth; this artificial beat differs in no obvious characters from a natural beat. The latent period of such an artificial beat is re-

markably long, the length varying within very wide limits. Thus the cardiac contraction is more like that of an unstriated than of a striated muscle. The beat is in fact a modified or peculiar form of peristaltic contraction. In the hearts of some animals, the ventricle forms a straight tube; and in these the peristaltic character of the beat is obvious; but in a twisted tube like that of the vertebrate ventricle, ordinary peristalsis would be impotent to drive the blood onward, and is accordingly so far modified that the peristaltic character of the beat is recognised only when the action of the heart becomes slow and feeble.

One great feature of the cardiac beat produced by artificial stimulation is seen in the absence of any relationship between the strength of the stimulus employed to produce a beat and the amount of contraction evoked. The beat with which a heart responds to a stimulus, *e.g.* a single induction shock, is, if there be any response at all, equally large when a feeble as when a strong stimulus is used, though the strength of the beat evoked either by a strong or a weak stimulus may vary very considerably within even a very short period of time.

When a second induction shock is sent in at a certain interval after a first, the beat due to the second shock is often larger than the first, the beneficial effects of a contraction (see p. 77) being even still more manifest in the heart than in an ordinary skeletal muscle. Frequently by successive shocks of equal intensity a 'staircase' of beats of successively increasing amplitude may be produced.

When a second induction shock follows upon the first too rapidly, it is apparently without effect; no second beat is produced. So also when a series of rapidly repeated induction shocks are sent in, a certain number of them are thus 'ineffectual;' the application of the ordinary interrupted current gives rise not to a tetanus but to a rhythmic series of beats. The 'refractory period,' which is so brief in the skeletal muscle (see p. 69), is very prolonged in the cardiac muscle. So also in a spontaneously beating heart, induction shocks sent in at a certain phase of a cardiac cycle, *e.g.* the commencement of the systole, are ineffectual, though they produce forced beats when sent in at the other phases of the cycle.

Nervous mechanism of the Beat. The beat of the heart is an automatic action; the muscular contractions which constitute the beat are caused by impulses which arise spontaneously in the heart itself. This cannot be proved in the case of the warm-blooded vertebrates, for the hearts of these cease to beat very soon after removal from the body; but there is no reason whatever against, and every reason for, thinking that the heart of a mammal or of a bird is in its fundamental working exactly like that of a frog or of a turtle. We shall therefore take for granted that the principal laws of the heart's beat, which are shewn by the frog's heart, also hold good for those of higher animals.

The heart of a frog (or of a turtle or fish, &c.) will continue

¹ Cf. Bowditch, Ludwig's *Arbeiten*, 1871; and Marey, *Travaux du Laborat.* II. (1870), p. 63.

to beat for hours, or under favourable circumstances for days, after removal from the body. The beat goes on even after the cavities have been cleared of blood, and indeed when they are almost empty of all fluid. The beats are more vigorous, and last longer, when the heart is removed by incisions which leave the sinus venosus still attached to the auricles. The excised heart does however, though not so readily, continue to beat spontaneously when removed by an incision carried through the auricles so that a portion of the auricles together with the sinus venosus is left behind in the body. In this case the parts left behind are seen also to go on beating by themselves.

If in an excised heart the ventricle be divided from the auricles, both ventricle and auricle will go on beating. Each moiety has then an independent rhythm. If the spontaneously-beating auricle be bisected longitudinally, each lateral half will go on beating spontaneously. Each lateral half may be still further divided, and yet the pieces will under favourable circumstances go on pulsating. The ventricle will go on beating when bisected longitudinally; but if it be cut across transversely, the lower half remains motionless, while the upper goes on pulsating. The power of spontaneous pulsation is limited to the extreme base, for if the transverse incision be carried only at a little distance from the auriculo-ventricular groove all power of spontaneous pulsation is lost in the lower part. When these several parts of the heart are examined, it is found that in all of those which beat spontaneously, ganglia are present, while from the ventricle except at the extreme base ganglia are absent. There are ganglia in the sinus, ganglia in the auricular septum and walls, ganglia in the auriculo-ventricular groove, but none have been found in the mass of the ventricle itself. From these facts the conclusion is drawn that the spontaneous pulsations in the heart are in some way associated with, and due to the action of, the ganglia scattered in its substance. Of these ganglia those in the sinus seem more potent than those in other parts of the heart.

The exact manner in which these ganglia act is still obscure. Though the portion comprising the lower two-thirds of the ventricle remains after separation from the basal third permanently quiescent, it may be thrown into rhythmic contractions, indistinguishable in their character from normal beats, by the application of the constant current. It will also give apparently spontaneous rhythmic beats, when supplied, according to the Leipzig method, with rabbit's serum or dilute rabbit's blood¹. For this purpose, a tube, completely divided by a longitudinal partition into two canals, is introduced into the cavity of the ventricle, and the latter securely ligatured round the tube at the junction of the upper and middle thirds. Fluid introduced through one canal at a low pressure distends the ventricle, and when a beat takes place, is driven out through the other canal. Fed in this way with rabbit's serum or blood, almost any part of the ventricle may be made after a period

¹ Meranowicz, Ludwig's *Arbeiten*, 1875, p. 132. Compare however Bernstein, *Centralbl. f. Med. Wiss.* 1876, 385, 435.

of rest to execute what are apparently spontaneous rhythmic pulsations. If it be urged that the serum or blood is a stimulus which provokes contractions, there still remains the difficulty, why the continued stimulus produces not a continued contraction, but a rhythmic pulsation. Moreover, in the case of the rhythmic beats evoked by the constant current, the current cannot during its passage be regarded as a stimulus in the ordinary sense of the word.

Inhibition of the Beat. The beat of the heart may be stopped or checked, *i. e.* may be inhibited by efferent impulses descending the vagus nerve.

If while the beats of the heart of a frog or rabbit are being carefully registered (Fig. 30) an interrupted current of moderate strength

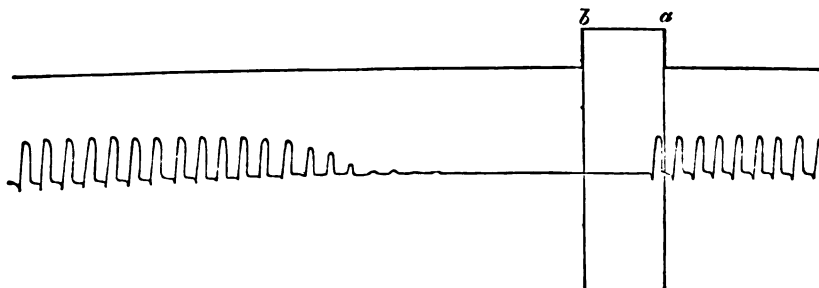

FIG. 30. INHIBITION OF FROG'S HEART BY STIMULATION OF THE VAGUS.

The contractions of the ventricle are registered by means of a simple lever, so that each rise of the lever corresponds to a beat. The interrupted current was thrown in at *a*, and shut off at *b*. It will be seen that one beat occurred after *a*, and that the pause continued for some time after *b*. To be read from right to left.

be sent through one of the vagi, the heart is seen to stop beating. It remains for a time in diastole, perfectly motionless and flaccid. If the duration of the current be short and the strength of the current great, the standstill may continue after the current has been shut off; the beats when they reappear are generally at first feeble and infrequent, but soon reach or even go beyond their previous vigour and frequency. Czermak, by pressing his vagus against a small osseous tumour in his neck, and thus mechanically stimulating the nerve, was able to stop at will the beating of his own heart; it need hardly be added that such an experiment is a dangerous one.

The effect is not produced instantaneously; if on the curve the point be exactly marked as at *a* (Fig. 30) where the current is made, it will frequently be found that one beat at least occurs after the current has passed into the nerve. In other words, the inhibitory action of the vagus has a long latent period; this has been estimated by Donders to last in the rabbit .16 sec. The inhibitory effect is at a maximum soon after the moment of application of the current, and diminishes gradually onward. The effect, especially with weak currents, is much more in the direction of prolonging the diastole, than

of diminishing the extent of the systole. Hence with weak currents, no actual stoppage takes place, but the pauses between the beats are much prolonged, especially at the beginning of the action of the current, and the pulse thereby rendered slow. If the application of the current for a time be soon followed by a second application of the same current, the effects are very markedly less. This is due not to exhaustion of the vagus fibres but to something which has taken place in the heart, possibly in the ganglia, for a stimulation, say of the left vagus, immediately following that of the right vagus, is equally diminished in effect. During the standstill, direct stimulation of the heart, as by touching the auricle or ventricle, will produce a single beat; though spontaneous pulsations are absent, the irritability of the muscular fibres is not destroyed.

The stimulus need not be an interrupted current; mechanical and chemical stimulation of the vagus also produces inhibition, though less readily.

After atropin, even in a minute dose, has been injected into the blood, stimulation of the vagus even with the most powerful currents produces no inhibition whatever. The heart continues to beat as if nothing were happening; atropin in some way or other does away with the normal inhibitory action of the vagus.

The above facts shew that the events which are at the bottom of vagus inhibition are complex. The following considerations render this still more evident.

A single-induction shock rarely produces an effect which can be measured; but a series of shocks repeated at intervals (the interval may be equal to or even greater than the length of a whole cardiac cycle) produces very marked inhibition.

The stimulus may be applied at any part of the course of either vagus (though it frequently happens in the frog that one vagus is more efficient than the other); but perhaps the most marked effects are produced, when the electrodes are placed on the boundary-line between the sinus venosus and the auricles.

In slight urari poisoning, the inhibitory action of the vagus is still present; in the profounder stages it disappears, but even then inhibition may be obtained by applying the electrodes to the sinus.

In order to explain this result it has been supposed that the inhibitory fibres of the vagus terminate in an inhibitory mechanism (probably ganglionic in nature), seated in the heart itself, and that the urari, while in large doses it may paralyse the terminal fibres of the vagus, leaves this inhibitory mechanism intact and capable of being thrown into activity by a stimulus applied directly to the sinus. After atropin has been given, inhibition cannot be brought by stimulation either of the vagus fibres or of the sinus, or indeed of any part of the heart. Hence it is inferred that atropin, unlike urari, paralyzes this intrinsic inhibitory mechanism itself.

After the application of muscarin or jaborandi, the heart stops beating, and remains in diastole in perfect standstill. Its appearance is then exactly that of a heart inhibited by profound and lasting vagus stimulation. This effect is not hindered by urari. The application however of a small

dose of atropin at once restores the beat. These facts are interpreted as meaning that muscarin (or jaborandi) stimulates or excites the inhibitory apparatus spoken of above, which atropin paralyses or places *hors de combat*. It is doubtful whether the standstill produced by muscarin after it has been put on one side by atropin, can be brought back again by further doses of muscarin. In the case of jaborandi it can. When jaborandi is carefully applied to the ventricle externally, the ventricle may be brought to a standstill, while the auricles continue to go on beating as usual¹.

Nicotin, when given, first slows the heart even to a standstill; but after a while the beats recover their usual rhythm. Stimulation of the vagus is then found to have no effect; muscarin however at once produces a standstill, which in turn may be removed by atropin. The initial slowing effect is absent if atropin or urari be previously given. These facts are interpreted as shewing that nicotin first excites the terminal fibres of the vagus, producing inhibitory effects, but that this excitement ends in an exhaustion of these fibres. The action of the drug however is limited to the terminal fibres of the vagus, and does not bear on the intrinsic inhibitory apparatus, with which these fibres are connected; hence while, after nicotin poisoning, stimulation of the trunk of the vagus is ineffectual, a small dose of muscarin, which acts directly on the apparatus itself, produces standstill.

If a ligature be drawn tightly round the junction of the sinus venosus with the auricles, or if the auricles be separated from the sinus by an incision carried along the boundary-line between the two, a standstill is produced closely resembling vagus inhibition, and, still more, muscarin standstill. The quiescence thus induced may last an indefinite time. This experiment we owe to Stannius². During the standstill, there is a great tendency for the ventricle to beat before the auricles, when a pulsation is induced by a stimulus applied directly to the heart; and when the ventricle is separated by an incision from the auricles, the former will recommence beating, while the latter remain as quiescent as before.

Two interpretations have been offered of this standstill. It has been suggested that the ligature or section stimulates the endings of the vagus, and so produces inhibition. This is disproved by the fact that the standstill appears equally well, whether atropin have been previously given or not. According to the other view, the really automatic movements of the heart depend on the ganglia in the sinus, the pulsations which appear in the isolated ventricle or auricles being in reality reflex pulsations, or pulsations caused by some stimulus not really automatic, and therefore not so lasting; or, if there be an automatic apparatus in ventricle or auricle, it is kept in check by the action of the inhibitory apparatus spoken of above, and only makes its presence felt on some stimulus being applied. This view again is disproved by the fact that if the sinus be gradually separated from the auricles, no standstill takes place. The whole subject needs further elucidation.

Reflex Inhibition. This inhibitory action of the vagus may be brought about by reflex action. If the abdomen of a frog be laid bare, and the intestine be struck sharply, as with the handle of a

¹ Langley, *Journ. Anat.* x. (1875) 187.

² Muller's *Archiv*, 1852, p. 85.

scapel, the heart will stand still in diastole with all the phenomena of vagus inhibition. If the *nervi mesenterici* or the connections of these nerves with the sympathetic chain be stimulated with the interrupted current, cardiac inhibition is similarly produced. If in these two experiments both vagi are divided, or the medulla oblongata destroyed, inhibition is not produced, however much either the intestine or the mesenteric nerves be stimulated. This shews that the phenomena are caused by impulses ascending along the mesenteric nerves to the medulla, and so affecting a portion of that organ as to give rise by reflex action to impulses which descend the vagi as inhibitory impulses. The portion of the medulla thus mediating between the afferent and efferent impulses may be spoken of as the cardio-inhibitory centre.

If the peritoneal surface of the intestine be inflamed, very gentle stimulation of the inflamed surface will produce marked inhibition; and in general the alimentary tract seems in closer connection with the cardio-inhibitory centre than other parts of the body; but apparently stimuli if sufficiently powerful will through reflex action produce inhibition from whatever part of the body they may come. Thus crushing a frog's foot will stop the heart. In ourselves the fainting from emotion or from severe pain is the result of a reflex inhibition of the heart, the afferent impulses in the one case at least, and probably in both cases, reaching the medulla from the brain.

Direct stimulation of the centre itself, such as occurs during the destruction of or results from injury to the medulla, of course produces inhibition.

Thus by nervous links, the regulative action of the inhibitory mechanism is brought into more or less close communion with all parts of the body.

The question naturally arises, Has this cardio-inhibitory centre any automatic action?

In the dog, and also, though to a far less extent, in the rabbit, section of both vagi is followed by a quickening of the heart's beat. This result may be interpreted as shewing that the centre in the medulla exercises a permanent restraining influence on the heart; that organ in fact being habitually curbed up. (The argument that the effects of an artificial stimulation of the vagus soon wear off, and that therefore a permanent stimulation of the vagi, leading to permanent inhibitory action, would be impossible, may be met by the suggestion that the effects of natural stimulation need not necessarily wear off.) If however, previous to the section of the vagi, afferent impulses to the centre in the medulla are cut off by the section of the spinal cord below the medulla, and by division of the cervical sympathetic chain, no acceleration follows the division of the vagi. This would shew that the action of the medulla in this matter is purely reflex, and not automatic. Such an experiment, however, introduces many sources of error; and perhaps, the question itself is at bottom a barren one. Granting, however, the existence of a centre in the medulla, which either automatically or otherwise is in permanent action, it is obviously open to us to speak of reflex inhibition as being brought about by

influences which augment the action of that centre. But we have seen that active nervous centres are subject, not only to augmentative, but also to inhibitory influences. Hence the cardio-inhibitory centre might itself be inhibited by impulses reaching it from various quarters. In other words, the beat of heart might be quickened by a lessening of the normal action of its inhibitory centre in the medulla. It is in fact probable, that many cases of quickening of the heart's beat are produced in this way; though the matter requires further investigation.

Accelerator nerves. The heart's beat may in the mammal be quickened, even after division of both vagi, by direct stimulation of the cervical spinal cord. The effects produced, however, are very complex, and led, on their first being made known, to much discussion, one outcome of which was the discovery of certain nerves of a very peculiar character, which pass from the cervical spinal cord, frequently along the nerve accompanying the vertebral artery, and reach the heart through the last cervical and first thoracic ganglia; these have been called the 'accelerator nerves.' Their

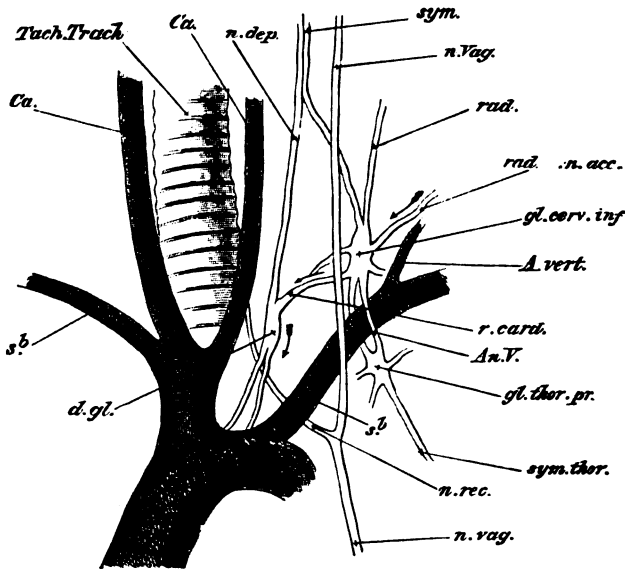

FIG. 31. THE LAST CERVICAL AND FIRST THORACIC GANGLIA IN THE RABBIT. (Left side.) (Somewhat diagrammatic, many of the various branches being omitted.)

Trach. Trachea. *ca.* carotid artery. *sb.* subclavian artery. *n. Vag.* the vagus trunk. *n. rec.* the recurrent laryngeal. *sym.* the cervical sympathetic nerve ending in the inferior cervical ganglion, *gl. cerv. inf.* Two roots of the ganglion are shewn, *rad.* the lower of the two accompanying the vertebral artery, *A. vert.*, being the one generally possessing accelerator properties. *gl. thor. pr.* the first thoracic ganglion. Its two branches communicating with the cervical ganglion surround the subclavian artery forming the annulus of Vieussens. *sym. thor.* the thoracic sympathetic chain. *n. dep.* depressor nerve. This is joined in its course by a branch from the lower cervical ganglion, there being a small ganglion at their junction, from which proceed nerves to form a plexus over the arch of the aorta. It is this branch from the lower cervical ganglion which possesses accelerator properties—hence the course of the accelerator fibres is indicated in the figure by the arrows.

course is different in the rabbit and in the dog, see Figs. 31 and 32, and indeed varies even in the same kind of animal. Stimulation of these nerves with the interrupted current, causes a quickening of the heart's beat, in which, what is gained in rate is lost in force, for the blood-pressure is not necessarily increased, but may remain the same, or even be diminished. The latent period of the action of these nerves may be enormously long, amounting to as much as 10 seconds. The effect is therefore a very appreciable time in making its appearance; rising gradually to a maximum, it after a while slowly declines. The effects require for their production very strong currents; and it is a very remarkable feature of these nerves (in cats at least), that absolute exhaustion is with difficulty produced in them¹. They seem² to be unaffected by the various poisons which act upon the vagus and other parts of the nervous system of the heart, and are effective in the midst of profound asphyxia. Their influence is closely dependent on temperature; at low temperatures their influence is slight, and long in

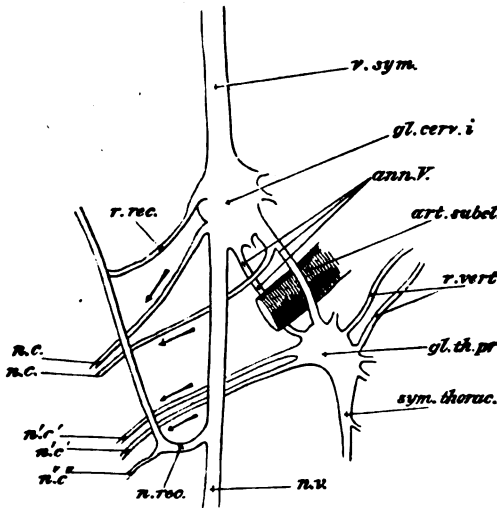

FIG. 32. THE LAST CERVICAL AND FIRST THORACIC GANGLIA IN THE DOG.

The cardiac nerves of the Dog. The figure is largely diagrammatic, and represents the left side.

v. sym. the united vagus and cervical sympathetic nerves. gl. cerv. i. the inferior cervical ganglion. n. v. the continuation of the trunk of the vagus. ann. V. the two branches forming the annulus of Vieussens round the subclavian artery, art. subcl., and joining gl. th. pr., the first thoracic or stellate ganglion (the branch running in front of the artery is considered by Schmiedeberg to be an especial channel of accelerator fibres). sym. thorac. the sympathetic trunk in the thorax. r. vert. communicating branches from the cervical nerves running alongside the vertebral artery, the rami vertebrales. n. rec. the recurrent laryngeal. n. c. cardiac branches from the lower cervical ganglion, accelerator nerves of Schmiedeberg. n' c'. cardiac branches from the first thoracic ganglion, accelerator nerves of Cyon. n'' c'. cardiac branch from recurrent nerve. r. rec. branch from lower cervical ganglion to the recurrent nerve, often containing accelerator fibres.

¹ Boehm. *Archiv f. Exp. Path.* iv. (1875) 255.

² Schmiedeberg, *Ludwig's Arbeiten*, 1871.

making its appearance ; as the temperature rises their action becomes more and more powerful. They are not to be considered as antagonistic to the vagi ; for if during maximum stimulation of the accelerator nerves the vagus be stimulated, even with minimum currents, inhibition is produced with the same readiness as if these were not acting¹. The period of inhibition however is followed by a period of acceleration similar to that produced by the action of the accelerator alone, the vagus action appearing simply to prevent, during its continuance, the manifestation of the accelerator action but not otherwise to modify it. We know at present little concerning the share which these nerves take in the natural actions of the economy. If, as later researches of Baxt would seem to shew, their accelerating effect is characterized by an actual shortening of the cardiac systole, it is obvious that the quickening of the heart's beat produced by their action is something quite different from the quickening indirectly brought about by a diminution of the activity of the cardio-inhibitory centre.

The beat of the heart then may be modified, and so adapted to the needs of the body, by means of the vagi nerves and the general nervous system of the body. It is however also affected by influences brought to bear directly on the heart itself. Thus chemical changes in the blood, as seen for instance in the action of the poisons discussed above, profoundly affect the beat of the heart. When the heart by the method described above (p. 143) is fed with rabbit's serum, the beats, whether spontaneous or provoked by stimulation, are apt to become intermittent and to arrange themselves into groups. This intermittence is due to the chemical action of the serum ; and it is probable that the cardiac intermittence seen during life has often a similar causation. Various chemical substances in the blood, natural or morbid, may thus affect the heart's beat by acting on its muscular fibres, its reflex or automatic ganglia, or its intrinsic inhibitory apparatus.

The physical or mechanical circumstances of the heart also affect its beat ; of these perhaps the most important is the amount of the distension of its cavities. The contractions of cardiac muscle, like those of ordinary muscle (see p. 69), are increased up to a certain limit by the resistance which they have to overcome ; a full ventricle will, other things being equal, contract more vigorously than one less full ; though, as in muscle, the limit at which resistance is beneficial may be passed, and an over-full ventricle will cease to beat at all.

The influences of resistance in the case of the heart are, however, more complex than those of ordinary muscle, since in the former we have to deal with the rate as well as the vigour of the beat.

The effects of mechanical conditions, and at the same time the manner in which they are complicated by vital factors, may be well shewn in discussing

The relation of the heart's beat to blood-pressure. When the blood-pressure is high, not only is the resistance to the ventricular

¹ Baxt, *Die Stellung des N. vagus zum N. accelerans*, Ludwig's Arbeiten, 1875.

systole increased, but, other things being equal, more blood flows through the coronary artery. Both these events would increase the work of the heart, and we might expect that the increase would be manifest in the rate of the rhythm as well as in the force of the individual beats. As a matter of fact, however, we do not find this. On the contrary, as Marey has insisted, the relation of heart-beat to pressure may be put almost in the form of a law, that "the rate of the beat is in inverse ratio to the arterial pressure;" a rise of pressure being accompanied by a diminution, and fall of pressure with an increase of the pulse-rate. This however only holds good if the vagi be intact. If these be previously divided, then in whatever way the blood-pressure be raised—whether by injecting blood or clamping the aorta, or increasing the peripheral resistance, through that action of the vaso-motor nerves which we shall have to describe directly—or in whatever way it be lowered, no very clear and decided relation between blood-pressure and pulse-rate is observed¹. It is inferred therefore that the effect of increased blood-pressure in slowing the pulse, when the vagi are intact, is brought about through the high blood-pressure stimulating the cardio-inhibitory centre in the medulla and thus partially inhibiting the heart.

When the blood-pressure, after section of the vagi, is raised by the injection of additional blood or by clamping the aorta, the heart's beats are increased in strength, as shewn by the larger excursions of the manometer; the fact that this is not accompanied by any change in the rate, suggests that there must be some compensating agency at work. Sometimes, even after section of the vagi, a slight slowing is observed when the pressure is increased; this has been attributed to the action of the increased arterial pressure on the endings of the vagus fibres in the heart itself.

The Effects on the Circulation of Changes in the Heart's Beat.

Any variation in the heart's beat directly affects the blood-pressure unless some compensating influence be at work. The most extreme case is that of complete inhibition. Thus if, while a tracing of arterial pressure is being taken, the beat of the heart be suddenly arrested, some such curve as that represented in Fig. 33 will be obtained. It will be observed that immediately after the last beat, there is a sudden rapid fall of the blood-pressure, the curve described by the float more or less closely resembling a parabola. At the close of the last systole, the arterial system is at its maximum of distension; forthwith the elastic reaction of the arterial walls propels the blood forward into the veins, and there being no fresh fluid injected from the heart, the fall of the mercury is unbroken, being rapid at first, but slower afterwards, as the elastic force of the arterial walls is more and more used up. With the returning beats, the mer-

¹ Nawrocki, Ludwig's *Festgabe*, p. ccv.

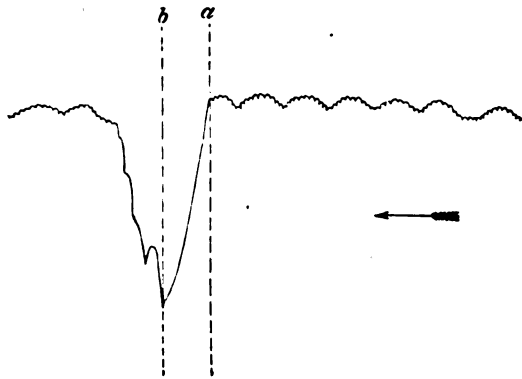

FIG. 33. TRACING, SHEWING THE INFLUENCE OF CARDIAC INHIBITION ON BLOOD-PRESSURE. FROM A RABBIT.

The current was thrown into the vagus at *a* and shut off at *b*. It will be observed that one beat is recorded after the commencement of the stimulation. Then follows a very rapid fall, continuing after the cessation of the stimulus. With the returning beats, the mercury rises by leaps until the normal pressure is regained.

cury correspondingly rises in successive leaps until the normal pressure is regained. The size of these returning leaps of the mercury may seem extraordinary, Fig. 34, but it must be remembered that by far the greater part of the force of the first few strokes of the heart is expended in distending the arterial system, a small portion only of the blood which is ejected into the arteries passing on into the veins. As the arterial pressure rises, more and more blood passes at each beat through the capillaries, and the rise of the mercury at each beat becomes less and less, until at last the whole contents of the ventricle passes at each stroke into the veins, and the mean arterial pressure is established. To this it may be added, that the force of the individual beats is somewhat greater after than before inhibition; that is to say, the period of depression is followed by a period of reaction, of exaltation. Besides, the inertia of the mercury tends to magnify the effects of the initial beats.

If while the force of the individual beats remains constant the frequency is increased or diminished, and *vice versa*, if while the frequency remains the same the force is increased or diminished, the pressure is proportionately increased or diminished. This clearly must be the case; but obviously it is quite possible that the beats might, while more frequent, so lose in force, or while less frequent, so increase in force, that no difference in the mean pressure should result. And this indeed is not unfrequently the case. So much so, that variations in the heart-beat must always be looked upon as a far less important factor of blood-pressure than the peripheral resistance.

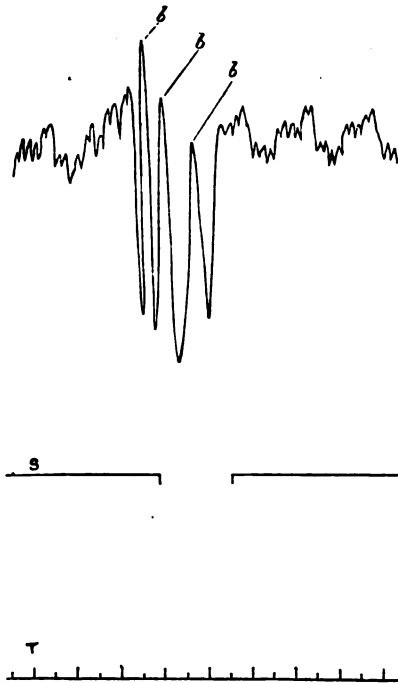

FIG. 34. BLOOD-PRESSURE DURING CARDIAC INHIBITION. FROM A DOG.

(The tracing reads from right to left.)

The line T indicates the time at which the recording surface was travelling, the vertical lines marking seconds. The line S indicates the application of the stimulus, an interrupted current being thrown into the vagus during the break in the line. It will be noticed that in this case, the stimulus being comparatively weak, the beats recommenced before the current was shut off. The large leaps of the mercury, δ , caused partly by the slowness of the first beats after the pause, are very conspicuous, indeed unusually large.

Thus when the heart's beat is quickened by stimulation of the accelerator, no increase in the blood-pressure is observed. This, in the absence of any peripheral changes, must result from a proportionate diminution of the force of the individual strokes.

An increase in the quantity of blood ejected at each beat must necessarily augment, and a decrease diminish, the blood-pressure, other things remaining the same. But the quantity sent out at each beat, on the supposition that the ventricle always empties itself at each systole, will depend on the quantity entering into the ventricle during each diastole, and that will be determined by the circumstances not of the heart itself, but of some other part or parts of the body.

SEC. 5. CHANGES IN THE CALIBRE OF THE MINUTE ARTERIES. VASO-MOTOR ACTIONS.

The middle coat of all arteries contains circularly disposed plain muscular fibres. As the arteries become smaller, the muscular element becomes more and more prominent as compared with the elastic element, until, in the minute arteries, the middle coat consists entirely of a series of plain muscular fibres wrapped round the elastic internal coat. Nerve-fibres belonging to the sympathetic system are distributed largely to blood-vessels, but their terminations have not as yet been clearly made out. By galvanic, or still better by mechanical stimulation, this muscular coat may, in the living artery, be made to contract. During this contraction, which has the slow character belonging to the contractions of all plain muscle, the calibre of the vessel is diminished.

If the web of a frog's foot be examined under the microscope, any individual small artery will be found to vary in calibre, being sometimes narrowed and sometimes dilated. During the narrowing, which is obviously due to a contraction of the muscular coat of the artery, the attached capillary area with the corresponding veins becomes less filled with blood, and paler. During the stage of dilation, which corresponds to the relaxation of the muscular coat, the same parts are fuller of blood and redder. It is obvious that, the pressure at the entrance into any given artery remaining the same, more blood will enter the artery when relaxation takes place and consequently the resistance offered by the artery is lessened, and less when contraction occurs and the resistance is consequently increased. The blood always flows in the direction of least resistance.

The small arteries frequently manifest what may be called spontaneous variations in their calibre, and these variations are very apt to take on a distinctly rhythmical character. If a small artery in the web of the frog be carefully watched, it will be seen from time to time to vary very considerably in width, without any obvious change taking place in the heart's beat or any events occurring in the general vaso-motor system. Similar variations may be witnessed in the vessels of the mesentery of a mammal.

The most striking and most easily observed instance of rhythmical constriction and dilation is to be found in the median artery of the ear of the rabbit. If the ear be held up before the light, it will be seen that at one moment the artery appears as a delicate hardly visible pale streak, the whole ear being at the same time pallid. After a while the artery slowly widens out, becomes thick and red, the whole ear blushing, and many small vessels previously invisible coming into view. Again the artery narrows and the blush fades away; and this may be repeated at somewhat irregular intervals several times a minute. The extent and regularity of the rhythm are markedly increased if the rabbit be held up by the ears for a short time previous to the observation. If the sympathetic be severed, these rhythmic movements cease for a time; but in the course of a few days are re-established, even if the superior cervical ganglion be removed. Thus

though normally dependent on the central nervous system (unless we suppose that the mere section of the nerve is sufficient to create a shock lasting several days) these rhythmic movements can make their appearance independently of that system. Some local mechanism is therefore suggested; and yet no ganglionic cells have been discovered which would serve as such a mechanism. Similar rhythmic variations in the calibre of the arteries have been observed in several places, *e.g.* in the saphena artery of the rabbit, in the axillary artery of the tortoise, and in the small arteries of the muscles of the frog; probably they are widely spread. They may be compared with the rhythmic movements of the veins in the bat's wing and of the caudal vein of the eel.

The extent and intensity of the constriction or dilation are found to vary very largely. Irregular variations of slight extent occur even when the animal is apparently subjected to no disturbing causes. By appropriate stimulation the arteries may be either constricted, in some cases almost to obliteration, or dilated until they acquire double or more than double their normal diameter. Thus in the frog section of the sciatic nerve in the thigh causes a brief constriction followed frequently by a very marked dilation of the arteries, not only of the whole of that web, but of the rest of the foot. The whole limb in fact may become redder. Very frequently, however, section of the sciatic is followed by no distinct alteration in the calibre of the vessels of the web beyond perhaps an initial constriction. Stimulation of the peripheral stump of the divided nerve by an interrupted current of moderate intensity, is followed by a constriction, often so great as almost to obliterate some of the minute arteries. Sometimes, but not invariably, this constriction is followed by a dilation, which may or may not be marked.

The constriction of the arteries of the web as the result of nerve-stimulation, is more certain when the small nerve supplying the foot is operated on, than when the main trunk of the sciatic is stimulated high up.

These facts shew that the contractile elements of the minute arteries of the web of the frog's foot are capable by contraction or relaxation of causing constriction or dilation of the calibre of the arteries; and that this condition of constriction or dilation may be brought about through the agency of nerves.

Vaso-motor nerves. In the mammal, division of the cervical sympathetic on one side of the neck causes a dilation of the minute arteries of the head on the same side, and an increased supply of blood to the parts. If the experiment be performed on a rabbit, the effect on the circulation in the ear is very striking. The whole ear of the side operated on is much redder than normal, its arteries are obviously dilated, its veins unusually full, innumerable minute vessels before invisible come into view, and the temperature may be more than a degree higher than on the other side.

If the upper cut end of the nerve (*i.e.* the part connected with the head) be placed on a pair of electrodes, and stimulated with an

interrupted current, the ear again becomes pale, much paler than normal if the current be strong, the vessels diminish in size, so that the smaller ones disappear; and the temperature falls. On the current ceasing, the dilated and flushed condition, after a short pause, returns.

Division of the sciatic nerve in a mammal causes a similar dilation of the small arteries of the foot and leg. Where the condition of the circulation can be readily examined, as for instance in the hairless balls of the toes, the vessels are seen to be dilated and injected; and a thermometer placed between the toes shews a rise of temperature amounting, it may be, to several degrees. Division of the brachial plexus produces a similar dilation of the blood-vessels of the front limb. Division of the splanchnic nerve produces a dilation of the blood-vessels of the intestine. Division in the mammal of the lingual nerve on one side of the head, causes a dilation of the vessels in the corresponding half of the tongue. A similar effect follows division of the hypoglossal; and if both lingual and hypoglossal be severed, the effect is still more marked.

If one of the thin muscles of a frog be placed under the microscope, and its circulation watched while the nerve going to the muscle is still intact, it will be seen that division of the nerve is immediately followed by a dilation of the small arteries, and an increased flow of blood through the muscle.

In fact, in various parts of the body certain vascular areas stand in such a relation to certain nerves that the division of one of these nerves causes a dilation of the minute arteries in, and consequently an increased supply of blood to, a corresponding vascular area. These nerves, which belong sometimes to the sympathetic, sometimes to the cerebro-spinal system, are called 'vaso-motor' nerves.

It is frequently the case that the nerve, the division of which causes dilation, produces, when stimulated, effects other than those in which the blood-vessels are concerned, for instance the contraction of a skeletal muscle. The nerve cannot then be said to be simply a vaso-motor nerve, it is accordingly spoken of as containing vaso-motor fibres, just as an ordinary spinal nerve is spoken of as containing sensory and motor fibres.

Judging by what can be seen in the web of the frog's foot, it may fairly be said that the minute arteries of the vascular areas, when these and their appropriate vaso-motor nerves are in a normal condition, are in a state of moderate constriction, due to a permanent moderate contraction of the muscular coats, but that when the vaso-motor nerves are divided, the moderate contraction of the muscular coats gives way to a relaxation which produces a dilation of the arteries, and a consequent suffusion of the areas. This moderate contraction is often spoken of as a 'tonic' contraction. When it is present, the arteries are said to 'possess tone'. When it gives place to relaxation, as after division of the vaso-motor nerves, the arteries are said to have 'lost tone'.

Vaso-motor centre. The questions now arise: How is this tonic condition maintained, and what is the exact way in which division of a vaso-motor nerve causes 'loss of tone'? It has been said that division of the cervical sympathetic trunk causes a loss of tone in the arteries of the corresponding side of the head and face. This loss is evident in whatever part of its length the nerve be divided, from the upper to the lower cervical ganglion both included. The effect when the upper cervical ganglion is destroyed or removed is perhaps even more striking than when the trunk only is divided. Division of the sympathetic trunk below the inferior cervical ganglion, as for instance section of the thoracic trunk, does not produce this loss of tone in the vessels of the face, which however is produced by the division of the rami communicantes, passing from the lower cervical and upper dorsal spinal cord to the inferior cervical ganglion. Section, moreover, of a lateral half of the spinal cord in the cervical region produces loss of tone in the vessels of the face of the same side; and a section carried right across the spinal cord in this region, causes loss of tone on both sides of the head. The same effect is seen wherever the section of the cord be made between a lower limit, at the level of lower cervical and upper dorsal vertebræ, and a higher limit in the medulla oblongata, of which we shall speak directly. Section of the parts above and below these limits has no such effect.

Putting all these facts together, the simplest explanation seems to be as follows:

Under normal conditions, a certain tonic influence is continually being generated in a portion of the cerebro-spinal system, situate at the upper part of the medulla oblongata. This influence is as continually passing down the cervical spinal cord, leaves the cord by the rami communicantes (the paths here being somewhat variable), and ascending the cervical sympathetic, reaches the arteries of the head and face. The result of this influence is to keep these arteries in a state of tonic contraction. If by any of the sections spoken of above, this path is broken, the vaso-motor tract is interrupted, and in consequence the arteries, deprived of the wonted influence, lose their tone and dilate. Similarly with the other vascular areas. The vaso-motor influences governing the vessels of the lower limbs have been traced back with more or less distinctness along the sciatic and crural nerves, through the lumbar and sacral plexuses, and so into the spinal cord.

It is possible however that influences may pass out of the cord higher up into the abdominal sympathetic, and thence join the sciatic in the pelvis, or pursue a separate course along sympathetic nerves direct to the vessels.

The vaso-motor influences to the arm again may be traced back to the spinal cord along the brachial plexus.

Here also apparently influences may pass downwards through the cervical sympathetic by branches joining the brachial plexus, and also up-

wards along the thoracic sympathetic by branches leaving the spinal cord by the anterior roots of the 3rd to 7th dorsal nerves. These again may possibly pass in part directly to the vessels by a purely sympathetic tract.

The vaso-motor influences to the intestine may be traced back along the splanchnic nerves to the spinal cord. From all these, and other various parts, the influences may be traced back up the cord to the medulla oblongata. Hence, section of the spinal cord in the dorsal region, above the exit of the nerves of the sacral and lumbar plexuses, causes loss of tone in the blood-vessels of the lower limbs; section still higher up in the dorsal region causes in addition loss of tone in the arteries governed by the splanchnic nerve. Section in the upper cervical region adds to this loss of tone of the vessels of the fore limbs, and so on. Section in fact of the medulla oblongata, or of the cord immediately below the medulla, causes loss of tone all over the body, as shewn by the great diminution of the peripheral resistance leading to a large sinking of arterial pressure and an accumulation of blood in the venous system. Section of the crura cerebri above the medulla oblongata, *i. e.* above the upper limit spoken of above, produces no such lasting loss of tone, though it may have an immediate and passing effect.

These additional facts seem in turn to be most easily explained by supposing that there exists in the medulla oblongata a *vaso-motor centre* (presumably a group of ganglionic cells), whence tonic influences are continually proceeding to arteries all over the body, and maintaining the tone of all the vascular areas supplied by those arteries.

Owsjannikow¹ has attempted to define the limits of such a centre. He places the lower limit in the rabbit at 4 or 5 mm. above the point of the calamus scriptorius, and the higher limit at about 4 mm. higher up, viz. 1 or 2 mm. below the corpora quadrigemina. The centre according to him is bilateral, the halves being placed not in the middle line but more sideways and rather nearer the anterior than the posterior surface. The facts which led Cyon to believe that the vaso-motor centre extended higher up into the brain, seem capable of being otherwise explained.

Such a vaso-motor centre has an analogue in the intrinsic ganglia of the heart, and a still closer one in the respiratory centre, of which we shall speak hereafter.

The connection between a rhythmic and a tonic action is very close; so that the rhythmical variations in arteries described above may be regarded as special cases of tonic actions, the tonic being possibly converted into a rhythmic movement in the arteries themselves.

The existence of such a *general* vaso-motor centre in the medulla oblongata is not contradicted by the supposition that the spinal cord may act as a centre in special vaso-motor actions, as for instance when the lumbar cord serves as a centre for reflex vaso-motor actions, if not as

¹ Ludwig's *Arbeiten*, 1871, p. 21.

an automatic tonic centre for the blood-vessels of the lower limbs after division of the cord in the dorsal region¹. In the frog, indeed, any part of the spinal cord seems to act so readily as a vaso-motor centre², that it may be doubted whether we are justified in speaking of that animal as possessing a general medullary vaso-motor centre. And even in the mammal it is possible that the medullary vaso-motor centre is not so dominant as, in the description given above, it is represented to be. In the first place the vascular area governed by the splanchnic nerves is so capacious that the removal of the tonic influence exerted by those nerves may produce a fall of arterial pressure almost as large as that caused by the loss of tone over the rest of the body; so that the effects of loss of tone in the splanchnic area (and the vaso-motor centre of this area seems undoubtedly to lie in the medulla oblongata) might easily be confounded with the effects of loss of tone in the body generally. In the second place, in the experiments entailing section of the spinal cord in various regions, sufficient care has perhaps not been taken to distinguish between the immediately temporary (paralysing) and the ultimate, permanent effects of the operation. Thus the loss of tone in the lower limbs which is apparent immediately after section of the dorsal cord is in large measure at least temporary. It is more than probable that future inquiries will restrict the medullary vaso-motor centre on the one hand to being a real centre for special areas such as the splanchnic, and on the other to possessing general functions of a co-ordinating character only³.

Admitting for the present the existence of such a centre, and of such a tonic influence, it is obvious that though it is permissible to speak of a constant or habitual influence keeping up what may be called an average arterial tone, the amount of this influence must from time to time vary in both directions, being at one time augmented, and at another diminished or wholly suppressed. Further, although the nervous mechanism under discussion may be spoken of as the vaso-motor centre of all the arteries of the body, it must in reality be not a simple centre but a group of minor centres, more or less coordinate to each other, each minor centre governing a particular vascular area. This indeed is the very essence of its usefulness. All the good that could come out of an unvarying tone could be equally supplied by the mere mechanical properties of the arteries. The object of the vaso-motor mechanism is not so much to maintain a normal tone as to vary that tone, so that particular arteries may widen or narrow according to the needs of the economy. The tonic actions of all the arteries are gathered up into a centre in order that they may be more readily affected by diverse influences proceeding from all parts of the body. As a matter of fact, we find that just as the heart is affected either in the way of inhibition or of acceleration by influences reaching it along certain nerves, so the action of the vaso-motor centre may be exalted or depressed by nervous influences reaching it from various sentient surfaces.

¹ Goltz, *Pflüger's Archiv*, viii. 460. See also references, p. 167.

² Lister, *Phil. Trans.*, 1858. Part ii. p. 607.

³ Cf. Heidenhain, *Spinale Gefässreflexe*. *Pflüger's Archiv*, xiv. (1877) p. 518.

In one important feature the behaviour of the vaso-motor centre differs from that of the heart. It is necessary that the heart should have an automatic action, that it should go on beating, though no influences are being brought to bear upon it from the rest of the body. There is no necessity however for the vaso-motor centre to possess any automatism of its own, irrespective of events taking place in the rest of the body. Unless it is capable of being subjected to some influences from without, unless the tonic action which it exercises is capable of being either depressed or exalted as far as some vascular area or other is concerned, its presence is not needed. Its purpose as a centre is served if it simply acts as a centre of reflex action, mediating between afferent nerves bringing to it afferent impulses and vaso-motor nerves supplying vascular tracts. Hence the question, whether the vaso-motor centre is really an automatic or merely a reflex one, is a question of secondary consideration. The important fact is, that by means of it as a centre, afferent impulses may exalt or depress arterial tone. To which we may add the not less important fact, that the depressing or exalting influence thus exercised may be brought to bear either on the whole vascular system or on particular vascular areas.

Since in the living mammal the width of the arteries can rarely be seen or measured, and we are therefore compelled to judge of the constriction or dilation of an artery by its effects, we must, before giving the proofs of the statement just made, point out briefly what are the effects of the constriction or dilation of an artery. These are both local and general.

Let us suppose that the artery *A* is in a condition of normal tone, is midway between constriction and dilation. The flow through *A* is determined by the resistance in *A* and in the vascular tract which it supplies, in relation to the mean arterial pressure, which again is dependent on the way in which the heart is beating and on the peripheral resistance of all the small arteries and capillaries, *A* included.

If, while the heart and the rest of the arteries remain unchanged *A* be constricted, the peripheral resistance in *A* will increase, and this increase of resistance will lead to an increase of the general arterial pressure. This increase of pressure will tend to cause the blood in the body at large to flow more rapidly from the arteries into the veins. The constriction of *A* however will prevent any increase of the flow through it, in fact will make the flow through it less than before. Hence the whole increase of discharge from the arterial into the venous system must take place through channels other than *A*. Thus as the result of the constriction of any artery there occur, (1) diminished flow through the artery itself, (2) increased general arterial pressure, leading to (3) increased flow through the other arteries. If, on the other hand, *A* be dilated, while the heart and other arteries remain unchanged, the peripheral resistance in *A* is diminished. This leads to a lowering of the general arterial pressure,

which in turns causes the blood to flow less rapidly from the arteries into the veins. The dilation of *A* however permits, even with the lowered pressure, more blood to pass through it than before. Hence the diminished flow tells all the more on the rest of the arteries. Thus, as the result of the dilation of any artery, there occur (1) increased flow of blood through the artery itself, (2) diminished general pressure, and (3) diminished flow through the other arteries. Where the artery thus constricted or dilated is small, the local effect, the diminution or increase of flow through itself, is much more marked than the general effects, the change in blood-pressure and the flow through other arteries. When, however, the area the arteries of which are affected is large, the general effects are very striking. Thus if while a tracing of the blood-pressure is being taken by means of a manometer connected with the carotid artery, the splanchnic nerves be divided, a conspicuous but steady fall of pressure is observed, very similar to that which is seen in Fig. 35. The section of the splanchnic nerves cuts off the mesenteric arteries from their vaso-motor centre. They in consequence dilate, and the arteries governed by the splanchnic being very numerous, a large amount of peripheral resistance is thus taken away, and the blood-pressure falls accordingly, a large increase of flow into the portal veins takes place, and the supply of blood to the face, arms, and legs is proportionally diminished. It will be observed that the dilation of the arteries is not instantaneous but somewhat gradual, the pressure sinking not abruptly but with a gentle curve.

If the spinal cord be divided below the medulla all the arteries of the body are cut off from the vaso-motor centre. All the arteries previously governed by that centre dilate and the blood-pressure falls to a very low point. From the lack of due peripheral resistance the blood flows readily from the arteries into the veins, the head of blood, to borrow a phrase from the engineers, in the arteries cannot be got up, and hence much more blood is retained in the venous system than under normal conditions.

If during the low pressure caused by division of the splanchnic, the peripheral stump of the nerve be stimulated with the interrupted current, the intestinal arteries contract again to or beyond their former calibre, they offer in consequence a peripheral resistance equal to or greater than the normal, the pressure in the carotid is increased, and while less blood passes to the intestine, more flows through the face and limbs. So also when after division below the medulla the lower cut surface of the spinal cord is stimulated, there is general constriction of all the arteries¹, a general increase of resistance, the blood once more gathers head in the arterial system, and the pressure in the arteries rises again.

In both the cases just cited the heart is supposed to continue to

¹ This statement is possibly too general. There are some reasons for thinking that comparatively little constriction occurs in the arteries supplying muscles. Gaskell, *Journ. Anat. and Phys.* xi. (1877), p. 720.

beat with regularity, independent of the changes going on in the arteries. Hence when as the result of the stimulation of an afferent nerve there occurs a rise or a fall of general blood-pressure unaccompanied by any marked changes in the beat of the heart, we may safely infer that the afferent impulses started by the stimulation have travelled to the vaso-motor centre and there exalted or diminished the tone of some vascular tract.

A very characteristic instance of such an action is seen in the results of stimulating the depressor nerve in the rabbit. If while the pressure in an artery such as the carotid is being registered, the depressor nerve, which is a branch of the vagus running alongside the carotid artery and sympathetic nerve (Fig. 31. *n. dep.*), be divided, and its central end (*i.e.* the one connected with the brain) be stimulated with the interrupted current, a gradual but marked fall of pressure in the carotid is observed, lasting, where the period of stimulation is short, some time after the removal of the stimulus (Fig. 35). Since the beat of the heart is not markedly changed, the fall of pressure must be due to the diminution of peripheral resistance occasioned by the dilation of some arteries. If the splanchnic nerves are divided previous to the experiment, the fall of pressure when the depressor is stimulated is very small, in fact almost insignificant. The inference from this is clear; the depressor nerve exerts the depressing action on blood-pressure, which gives it its name, by causing a dila-

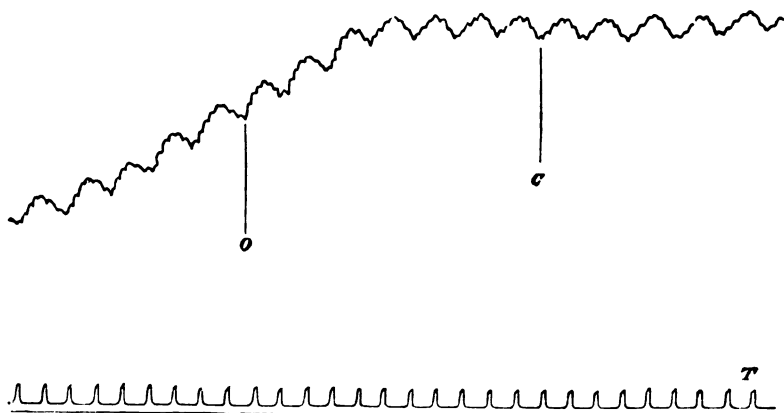

FIG. 35. TRACING SHewing THE EFFECT ON BLOOD-PRESSURE OF STIMULATING THE CENTRAL END OF THE DEPRESSOR NERVE IN THE RABBIT.

(To be read from right to left.)

T indicates the rate at which the recording surface was travelling; the intervals marked correspond to seconds. *C* the moment at which the current was thrown into the nerve; *O* the moment at which it was shut off. The effect is some time in developing and lasts after the current has been taken off. The larger undulations are the respiratory curves;—the pulse oscillations are very small.

tion of the intestinal arteries through the agency of the splanchnic nerves. The point of union between the two nerves, the depressor

and the splanchnic, is in the vaso-motor centre of the medulla. Hence we may say that the afferent impulses reaching the vaso-motor centre through the depressor, depress or inhibit a portion of that centre, so that the tonic impulses cease to pass down to the splanchnic nerves with their wonted vigour.

The depressor nerve is a special nerve, one specially connected with the vaso-motor centre, and having a special and constant function, viz. always to depress or lower tonic action. But all the afferent nerves of the body are more or less closely connected with the vaso-motor centre. Stimulation of almost any afferent nerve is found to affect blood-pressure, even while the heart's beat remains unchanged; that is, the stimulation of the afferent nerve influences through the vaso-motor centre the tone of some vascular tract. The influence may, according to circumstances, be in the way either of inhibition or exaltation. Thus if the central stump of the divided sciatic (or any other nerve containing afferent fibres) be stimulated under urari, a rise of pressure, sometimes almost the exact reverse of the fall caused by stimulating the depressor, is observed. The curve of the blood-pressure, after a latent period, rises; it begins to rise without any change in the heart's beat, gradually reaches a maximum, and after a while slowly falls again, even though the stimulation be still kept on. So constant is this result, that it has proved of great value in determining the existence of afferent fibres in any given nerve, and even the paths of centripetal impulses through the spinal cord. If, on the other hand, the animal be under chloral instead of urari, a fall quite similar to that caused by stimulating the depressor is observed instead of a rise. Thus, according to the condition of the vaso-motor centre, or to circumstances affecting it, the same stimulation of the same nerve may at one time produce a fall, and at another a rise of blood-pressure, *i. e.* may either depress or exalt the action of the centre.

The causes of this difference are not yet clearly worked out. Variations in respiration will not explain it. Nor can the solution be found by supposing that in urari poisoning cerebral functions are active while in chloral poisoning they are in abeyance. If the brain be removed without much bleeding, subsequent stimulation of a sensory nerve under urari still gives a rise of pressure. If there be much bleeding however a fall is witnessed. This suggests the idea that after bleeding and under chloral, the vaso-motor centre is enfeebled or exhausted, and that stimulation of the enfeebled or exhausted centre always causes depression. This view is supported by the fact, that in ordinary stimulation under urari the decline of the rise appears sooner, the more often the stimulation is repeated, and that after many repetitions the decline passes into a distinct fall, and at last only a fall is observed¹.

In the instances just quoted, the effect of the stimulation of the afferent nerve may be spoken of as a general one; it is the general

¹ Cf. Latschenberger and Deahna, *Pflüger's Archiv*, XII. (1876) p. 157.

blood-pressure which is diminished or increased ; though in the case of the depressor at all events the splanchnic nerves and intestinal vessels are the chief agents in the matter, it being the particular part of the vaso-motor centre governing the splanchnic area which is chiefly if not exclusively affected by the afferent impulses.

There are however some remarkable changes where a local effect can be readily distinguished from the general effect, because the two are in opposite directions. Thus if in a rabbit under urari, the central stump of the auricularis magnus nerve or of the auricularis posterior be stimulated, the rise of general pressure which is caused by the stimulation of this as of any other afferent nerve, is accompanied by a dilation of the artery of the ear. That is to say, the afferent impulses passing along the auricular nerve while affecting the vaso-motor centre in general, so as to cause constriction of many of the arteries of the body (but chiefly probably the splanchnic vessels), at the same time so affect that particular part of the centre which governs the artery of the ear, as to lead to the dilation of that vessel.

According to Lovén¹, to whom we are indebted for this observation, the local dilation in the ear is preceded by an initial constriction. A similar initial constriction has been witnessed in other cases of reflex dilation.

So also in the same animal stimulation of branches of the tibial nerve causes dilation of the saphena artery, together with constriction of other arteries, as shewn by the concomitant rise of pressure. And there are probably innumerable instances of the same kind of action going on in the body during life, for it is evident that the increased flow of blood to the organ which is the object of the local dilation, must be assisted if a general constriction is at the same time taking place in other regions.

The general effect may not always be obvious, may perhaps be often absent, so that the local dilation or constriction, as the case may be, is the only obvious result of the vaso-motor action. When the ear of the rabbit is gently tickled, the effect that is seen is a blushing of the ear, and though this may be in part due, as we shall see, to the action of a local mechanism, the case we have just cited shews that the vaso-motor centre must be largely engaged. When the right hand is dipped in cold water, the temperature of the left hand falls, on account of a reflex constriction of the vessels of the skin of that hand caused by the stimulus applied to the other. Many more instances might be quoted, and we shall again and again come upon examples. The numerous pathological phenomena classed under sympathetic action, such as the affection of one eye by disease in the other, are probably in part at least the results of reflex vaso-motor action.

We have said enough to shew that the calibre of the small arteries, which by determining the peripheral resistance forms one

¹ Ludwig's *Arbeiten*, 1866.

important factor regulating the flow of blood, is subject to influences proceeding from all parts of the body, the influences reaching the arteries in a reflex manner by means of the vaso-motor centre, the afferent impulses being for the most part carried by ordinary sensory nerves, while the efferent impulses pass along special vaso-motor nerves, which, though the vaso-motor centre lies in the medulla oblongata, have a great tendency to run in sympathetic tracts. Further, since the effects may be either local or general, the local being frequently opposite to the general, there is fair reason for assuming that the vaso-motor centre is a multiple centre, composed of minor centres governing particular vascular areas, so associated together that they may, according to circumstances, act either together or apart.

The reader can now appreciate the kind of proof offered by Owsjannikow (see p. 158) of the limits of the medullary vaso-motor centre. The rabbit being placed under urari, rise of pressure is seen to follow upon stimulation of the central stump of the sciatic. The amount of rise is not materially affected by sections of the brain above the upper limit of the centre. The sections being continued downwards, so soon as the centre is reached a diminution in the reaction is observed; and when the section passes through the lower limit, stimulation of the sciatic has no effect whatever.

The afferent impulses of course need not start from the peripheral nerve-endings. They may arise anywhere, as for instance in the brain. Thus an emotion originating in the cerebrum may either inhibit or exalt that portion of the vaso-motor centre which governs the vascular areas of the head and neck, and thus call forth either blushing or pallor. Nay more, changes may be induced in the vaso-motor centre itself without the need of any impulses reaching it from without. When we come to discuss the relations of respiration to the circulation, we shall see reason to think that the vaso-motor centre may be directly affected by the condition of the blood passing through it. If the quantity of oxygen in the blood be reduced, the tonic action of the vaso-motor centre is increased, a general arterial constriction takes place, and a rise of blood-pressure follows. The return of oxygen to the blood, on the other hand, lessens the action of the centre; the vessels dilate and pressure falls. We shall return to these phenomena later on.

It is more than probable that many substances introduced into the blood, or arising in the blood from natural or morbid changes, may affect blood-pressure by acting directly on the vaso-motor centre.

Local vaso-motor mechanisms. Although this central and general vaso-motor mechanism must play the chief part in the regulation of the blood-supply to various organs, there are phenomena which seem to compel us to admit the existence of local peripheral vaso-motor centres. An example of this is seen in the so-called *nervi erigentes*¹.

¹ Eckhard, *Beiträge*, iii. (1863) 123.

The erection of the penis is, putting aside the subsidiary action of muscular bands in restraining the outflow through the veins, chiefly due to the dilation of branches of the pudic arteries, whereby a large quantity of blood is discharged into the venous sinuses. Erection may in the dog be artificially produced by stimulating the *peripheral* ends of the divided *nervi erigentes*, which are branches from the first and second and sometimes from the third sacral nerve passing across the pelvis. On applying the interrupted current to the peripheral ends of these nerves, the corpora cavernosa at once become turgid. Evidently the efferent impulses passing along the nerves cause dilation by inhibiting the local tone. This local tone is not destroyed by the section of these or any other nerves; it is therefore independent of the spinal cord and of the general vaso-motor centre. We infer therefore that the local tone is maintained by some local mechanism, some local vaso-motor centre (probably a ganglionic group), whose action is inhibited by impulses reaching it along the *nervi erigentes*, just as the medullary vaso-motor centre is inhibited by impulses reaching it along the depressor nerve.

The somewhat similar case of the submaxillary gland we shall have to discuss more fully hereafter. At present we may say that the circulation in the gland appears also to be independent of the general vaso-motor centre, and to be governed by a vaso-motor centre of its own. Stimulation of the chorda tympani inhibits that local centre, and without producing any other change in the general circulation of the body, causes an abundant flow through the gland. Stimulation of the cervical sympathetic, on the other hand, exalts the local centre, and diminishes the flow through the gland; strong stimulation in fact almost arrests the flow.

In the exposition of vaso-motor nerves given above, the muscular coats of the arteries are considered as mere passive instruments in the hands of the far distant cerebro-spinal vaso-motor centres, with which they are connected merely by a greater or less length of simple nerve-fibres. There are facts, however, which clearly shew that the whole matter is much more complicated in nature.

In the first place, the dilation (loss of tone) which follows upon division of the cervical sympathetic, though it may remain for days, eventually gives way to a return of tone. The vessels resume their ordinary calibre, the ear regains its normal pallor; in fact, the difference, in a case of unilateral section of the sympathetic, between the two sides of the head, gradually disappears, and that too even when the upper cervical ganglion has been removed or destroyed. The same thing occurs after division of the sciatic in the mammal. On the day of the operation the difference of temperature between the hind feet of the two sides of the body may amount to four or five or even more degrees; but in a few days the two feet are equal in warmth. So also after division of the dorsal spinal cord. At first, the hind limbs are warmer than the fore limbs, but after a successful operation, in a few days their temperature falls until it becomes the same as that of the fore limbs and the rest of the body. The dilation which appears in a muscle after severance of its nerve in time

disappears; and a recovery of tone in the vessels of the frog has been witnessed even after complete destruction of the central nervous system. In fact, as far as we know, in all cases the loss of tonic influence which follows after section of a vaso-motor tract is a temporary one only; and the return of tone is certainly not due to any regeneration of the nervous tract. Further, this restored state of tone is susceptible of changes, of augmentation and decrease, like the original intact tone. Thus if the ear of a rabbit, to which tone has returned after section of the sympathetic, be gently titillated, the ear will blush, the blood-vessels will dilate, the tone will be inhibited, very much in the same way as if the sympathetic were entire. So also with the foot of a dog after section of the sciatic, tickling the ball of the toe will produce a temporary suffusion. In the frog, where the sciatic has been divided, a stimulus applied to the web will cause, according to circumstances, contraction or dilation stretching away from the point to which the stimulus is applied.

All these facts, and they might be multiplied, point to the conclusion, that there must be, in all cases, present in or near the small arteries, peripheral mechanisms, capable not only of maintaining, but within certain limits of regulating, local arterial tone. What is the exact nature of the local mechanism cannot at present be distinctly stated. In certain cases, *e.g.* the frog's web, and the rabbit's ear, the absence of ganglia, at least of ordinary ganglia, can be safely affirmed. Nor is there any satisfactory reason for referring the phenomena to ganglionic action in other cases.

Such being the case, the question arises, What then is the exact process through which section of the cervical sympathetic, for instance, causes dilation of the vessels of the ear? In reference to this, the following facts deserve attention.

Stimulation, by the interrupted current, of the peripheral stump of the divided cervical sympathetic, causes constriction of the blood-vessels. When the peripheral stump of the divided sciatic of the dog is stimulated with a somewhat strong current, a very temporary constriction is followed by a considerable dilation; the constriction is often so slight, that it may be overlooked. In the case of the sciatic of the frog, the constriction is often very great and the subsequent dilation very slight; and in the mammal by beginning with a weak stimulus and gradually increasing its strength, constriction may be maintained for some time. Stimulation of the peripheral stump of the divided lingual causes in the mammal dilation of the vessels of the tongue, without any foregoing constriction; the dilation caused by section is simply increased by subsequent stimulation. Stimulation of the hypoglossal, on the other hand, section of which also produces dilation, though less than in the case of the lingual nerve, is followed by constriction. The arteries of the mylo-hyoid, and probably of all other muscles of the frog¹, dilate not only when the nerve going to the muscles is cut, so as to sever the muscle from the central nervous system, but also when the nerve is stimulated either by the interrupted current, or by mechanical or chemical stimuli; and this holds good also of the muscles of the dog. So that while stimulation of a branch of the sciatic going to the foot causes constriction, the dilation only appearing as an after effect; the same stimulus applied to another branch of the same nerve going to a muscle, causes dilation without any previous con-

¹ Gaskell, W. H. *Journ. Anat. and Phys.* xi. (1877), p. 720.

striction, though sometimes constriction may follow. In each case the after effect is obvious only when strong stimuli are employed.

Thus in the case even of those nerves, the section of which, entailing severance of the vascular tract which they govern from the central nervous system, causes dilation, stimulation may produce either a constriction or a dilation unaccompanied by any constriction, and quite similar to the dilation caused by the stimulation of the chorda tympani or nervi erigentes; the dilation caused by stimulation may exceed that resulting from section. Sometimes, again, we may have constriction followed by dilation. How are these differences to be explained?

An apparently easy way of cutting the knot thus presented, is to suppose that there are two distinct kinds of vaso-motor nerves, constrictor nerves and dilator nerves, and that a vaso-motor tract may be entirely composed of one kind, or of the two mixed together. Thus, we may conceive that in the hypoglossal and cervical sympathetic, constrictor nerves are alone present, or are present in great excess; in the lingual and muscular nerves, and in the chorda tympani, dilator nerves only; and in the sciatic, both constrictor and dilator, the dilator being, in the mammal, somewhat in excess. In addition to this, we must suppose that the constrictor nerves are more easily excited and exhausted than the dilator nerves, in order to account for constriction preceding and giving way to dilation, when a trunk, such as the sciatic, containing both kinds of nerves, is stimulated.

Granting the existence of these constrictor and dilator fibres, the question still remains, Why does section of a nerve, such as the sciatic, produce dilation?

Goltz¹ has observed, that if a day or two after section of the sciatic, when the vessels are beginning to regain their tone, the peripheral stump be again cut or snipped, a fresh dilation, indicated by a fresh rise of temperature in the foot, takes place. By making a series of cuts along the nerve, from the cut end towards the periphery, by crimping it in fact, he succeeded in obtaining a rise of several degrees. Here evidently mere section of the nerve stimulated the supposed dilator fibres. Leaning on this observation Goltz has drawn the conclusion that the initial dilation consequent on division of the sciatic, is entirely due to the section stimulating the dilator fibres, and not at all to the withdrawal of any tonic influence. He has further extended this view, so as to refer all tone to peripheral mechanisms of some kind or other, and to convert the tonic centre of the medulla (and of the spinal cord) to a reflex centre for constrictor and dilator fibres. Thus blushing is, according to him, the result not of inhibition of the tonic centre, but of stimulation of a vaso-dilator centre. Against this view we may urge that, while neither by cutting, nor by stimulating in any way, such nerves as the cervical sympathetic and hypoglossal, can dilation be obtained, nevertheless the *initial* section of them always produces dilation. It seems impossible to explain this initial dilation, except on the supposition of a central tonic influence. Nor is there any real difficulty in the recovery of local tone after complete severance from the cerebro-spinal tonic centre. We have only to suppose that the local tonic mechanism, *whatever it be*, is, from habit, so adjusted as

¹ Pflüger's *Archiv*, ix. (1874) 174, xi. (1875) 52; cf. also Putzeys u. Tarchanoff, *Reichert u. Du Bois-Reymond's Archiv*, 1874. Ostroumoff, Pflüger's *Archiv*, xii. (1876) 219. Kendall u. Luchsinger, *ibid.* xiii. (1876) 197.

to act in concert with the general centre. On this centre it, under normal circumstances, largely relies. When the centre is sundered from it, it feels at once the loss, but gradually adapts itself to new circumstances, and finally does all the work itself. No instance is known of marked constricting effects following upon mere severance of a constrictor nerve at all comparable to the dilating effects which follow the section of a dilator nerve¹. Yet this ought to take place on Goltz's view. On the other hand, in the theory of a central vaso-motor action, the only permanent influence needed is one tending towards constriction or tone (the arteries can readily dilate of themselves through the pressure of the blood when this is removed); hence dilation is the natural and only effect of simple severance.

But if we admit that the blushing which occurs after section of the sympathetic is due to loss of tone, it is unnecessary to suppose that the blushing which comes from emotion is produced in any other way than by diminution of the normal tonic action of the (medullary) centre, and that pallor (when arising through the sympathetic and not from lessening of the heart's action) is produced in any other way than by an increase of the same normal tonic action of the centre; in other words, that constriction and dilation in the case of the natural action of the sympathetic differ on account of the degree to which the same central mechanism (in the medulla) is worked, and not by reason of the mechanism which is put into action in the one case being different from that which is put into action in the other. But if this is true of the central tonic mechanism, why should it not also be true of the peripheral local mechanism? why should not the nerves which when stimulated produce constriction, differ from those, stimulation of which produces dilation, not in possessing fibres of a different kind, but because their relations with the local mechanism are respectively such that impulses passing along the one increase, and along the other diminish, the action of that 'local centre'? So that the problem why the cervical sympathetic always produces constriction, and a muscular nerve always dilation, when stimulated artificially, is at bottom just the same problem as that why the depressor always lowers blood-pressure and why under urari stimulation of an afferent nerve causes a rise, and under chloral stimulation of the same nerve a fall, of blood-pressure.

If it could be shewn that the molecular arrangements of the nerve-endings were such that impulses passing along one kind of ending into the centre were liable to interfere with, while those passing along the other kind of ending were liable to add themselves to, the automatic impulses generated in the centre itself, the problem would be solved.

¹ All that has been observed is at times a slight passing constriction upon section of the cervical sympathetic (Kendall and Luchsinger) and anterior auricular nerve (Vulpian.)

² Kendall and Luchsinger, *op. cit.*, have shewn that in the case of the peripheral portion of a sciatic which has been divided for some little time, weak stimulation will produce a contraction, strong stimulation a dilation of the blood-vessels of the toes; and Lépine (*Compt. Rend. Soc. Biol.* March 4, 1876) finds the same stimulation of the sciatic may produce either constriction or dilation according as the foot is artificially warmed or cooled.

The Effects of local Vascular Constriction or Dilation.

Whatever be determined ultimately to be the *modus operandi* of vaso-motor mechanisms, the following fundamental facts remain of prime importance.

The tone of any given vascular area may be altered, positively in the direction of augmentation (constriction), or negatively in the way of inhibition (dilation), quite independently of what is going on in other areas. The change may be brought about by (1) stimuli applied to the spot itself, and acting either directly on the local mechanism, or indirectly by reflex action through the general vaso-motor centre; (2) by stimuli applied to some other sentient surface, and acting by reflex action through the general vaso-motor centre; (3) by stimuli (chemical, blood stimuli), acting directly on the general vaso-motor centre.

The effects of local dilation are local and general.

Local effects of dilation. The arteries in the area being dilated, offer less resistance than before to the passage of blood. Consequently, more blood than usual passes through them, filling up the capillaries and distending the veins. Owing to the diminution of the resistance, the fall of pressure in passing from the arteries to the veins will be less marked than usual; that in the small arteries themselves will be lowered, that in the corresponding veins heightened. The coats of the arteries during the dilation will suffer less strain than when in their tonic contracted condition; *i. e.* their elasticity will not be called into play to the same extent as before. Now, as has been seen, every portion of arterial wall has its share in destroying the pulse by converting the intermittent into a continuous flow. Hence, the stretch of dilated artery, its elasticity not being called into play, will not do its duty in further destroying the pulsations which reach it at the cardiac side. The pulsations will travel through it unchanged, and may, in certain cases, pass right on into the veins. This is frequently seen in the submaxillary gland, when the chorda tympani is stimulated. The channels being wider, resistance being less, and the force of the heart behind remaining the same, more blood than before passes through the area in a given time; or, put differently, the same quantity of blood passes through the area in a shorter time. The blood, consequently, as it passes into the veins is less changed than in the normal condition of the area. Sometimes the flow is so rapid that the oxy-hæmoglobin of the corpuscles is deoxidised to a much less extent than usual, and the venous blood still possesses an arterial hue. On the other hand, since more blood passes in a given time, there is an opportunity for an increase in the total interchange between the blood and the tissue. Thus the total work may be greater, though the share borne by each quantity of blood is less.

General effects of dilation. Supposing that the total quantity of blood issuing from the ventricle remains the same, that is to say, supposing that the quantity of blood put into circulation is constant, the surplus passing through the dilated area must be taken away from the rest of the circulation. Consequently the fullness of the dilated area will lead to an emptying of the other areas. This is seen very clearly when the dilated area is a capacious one. At the same time, local dilation causes a local diminution of peripheral resistance. This in turn causes a lowering of the general arterial pressure; to this we have already called attention.

The **effects of local constriction**, similarly local and general, are naturally the reverse of those of dilation.

In the vascular area directly affected, less blood passes through the capillaries in a given time, and in consequence less total interchange between the blood and the tissues takes place, though each unit volume of blood which does pass through is more deeply affected. The blood-pressure in the corresponding arteries is increased, and, if the area be large, the pressure in even distant arteries may be heightened.

Thus, to indicate results in a general manner, local dilation encourages a copious flow of blood through the area where the dilation is taking place, and, by reducing the blood-pressure, hinders the flow of blood into other areas. Local constriction, on the other hand, lessens the flow of blood in the particular area, and by heightening the blood-pressure tends to throw the mass of the blood on to other areas. Hence the great regulative value of the vaso-motor system. By augmenting or inhibitory influences (constrictor or dilating) applied either to peripheral mechanisms or to cerebro-spinal centres, and called forth by stimuli either intrinsic and acting through the blood, or extrinsic and acting through nervous tracts, the supply of blood to this or that organ or tissue may be increased or reduced: the surplus or deficit being carried away to, or brought up from, either the rest of the body generally, or some other special organ or tissue.

SEC. 6. CHANGES IN THE CAPILLARY DISTRICTS.

Possessing no muscular element in their texture, the capillaries, unlike the arteries, are subject to no active change of calibre. They are expanded when a large supply of blood reaches them through the supplying arteries, and, by virtue of their elasticity, shrink again when the supply is lessened or withdrawn; in both these events their share is a passive one.

It is true that certain active changes of form, due to movements in the protoplasm of their walls, have been described; but the effects of any such changes, even if common, must be quite subordinate.

Nevertheless the capillaries do possess active properties of a certain kind, which cause them to play an important part in the work of the circulation. They are concerned in maintaining the vital equilibrium which exists between the intra-vascular blood and the extra-vascular tissue, an equilibrium which is the central fact of a normal capillary circulation, of a normal interchange between the blood and the tissue, and thus of a normal life of the tissue. The existence of this equilibrium is best shewn when it is overthrown, as in the condition known as inflammation.

If an irritant, such as silver nitrate, or mustard, &c. be applied to a small portion of a frog's web, or a frog's tongue, inflammation is set up over a circumscribed area. In this area the following changes may be successively observed under the microscope. The first effect that is noticed is a dilation of the arteries, accompanied by a quickening of the stream. The capillaries become filled with corpuscles, and many passages previously invisible or nearly so on account of their containing no corpuscles come into view. The veins at the same time appear enlarged and full. These events, the filling of the capillaries and veins, and the quickening of the stream, are all simply the results of the diminution of peripheral resistance caused by the dilation of the small arteries. If the stimulus be very slight, this may all pass away, the arteries gaining their normal constriction, and the capillaries and veins in consequence returning to their half-filled condition; in other words, the effect of the stimulus in such a case is rather a temporary blush than actual inflammation. When the stimulus however is stronger, the quickening of the stream gives way to a slackening; this is not due to any returning constriction of the arteries, for they still continue dilated. The capillaries and veins get more and more crowded with corpuscles, the stream becomes slower and slower, until at last the movement of the blood in the now distinctly inflamed area ceases altogether. The phase of accelerated flow has given place to *stasis*. The capillaries, veins and small arteries are choked with corpuscles, and it may now be remarked that the red corpuscles seem to run together, so that their outlines are no longer distinguishable; they appear to have become fused into a yellow homogeneous mass. The large number of white corpuscles in the capillaries and veins is also a conspicuous feature. This stasis, this arrest of the current, is not due to any lessening of the heart's beat; the arterial pulsations, or at least the arterial flow, may be seen to be continued down to the inflamed area, and there to cease very suddenly. It is not due to any increase of peripheral resistance caused by constriction of the small arteries, for these continue dilated rather than constricted. It must therefore be due to some new and unusual resistance occurring in the capillary area itself. The increase of resistance is not caused by any change confined to the corpuscles themselves; for if after a temporary delay one set of corpuscles has managed to pass away from the inflamed area, the next set of corpuscles is subjected to the same delay and the same apparent fusion.

The cause of the resistance must therefore lie in the capillary walls, or in the tissue surrounding them, or, to speak perhaps more correctly, it depends on a disturbance of the relations which in a healthy area subsist between the blood in the capillaries on the one hand, and the capillary walls, with the tissue of which they are a part, on the other. After stasis has continued for some time, the tissue outside the capillary wall is seen to become crowded with white corpuscles, and in the tissue outside the veins are seen not only white but also red corpuscles. There can be no doubt that these have passed through the capillary and venous walls; they may indeed be seen in transit, but the mechanism of their passage is not exactly known. We have no clear proof that any distinct pores do exist in the vascular walls; and it seems probable that in the protoplasmic tissue which constitutes these walls, a temporary breach made by the passage of a corpuscle may be immediately and completely obliterated, just as a body may be thrust through a film such as that of a soap-bubble, and yet leave the film apparently entire, the internal cohesion of the film at once repairing the breach.

Except in cases where the stimulus produces permanent mischief, the inflammation after a while subsides. The outlines of the corpuscles become once more distinct, those on the venous side of the block gradually drop away in the neighbouring currents, little by little the whole obstruction is removed, the current through the area is re-established, and though the arteries and capillaries remain dilated for some considerable time, they eventually return to their normal calibre. Thus it is evident that the peripheral resistance in the capillaries (and consequently all that depends on peripheral resistance) is not merely a matter of the mechanical friction of the blood against the smooth walls of the blood-vessels, but is concerned with the vital condition of the tissues. When the tissue is in health, a certain resistance is offered to the passage of blood through the capillaries, and the whole vascular mechanism is adapted to overcome this resistance to such an extent that a normal circulation can take place. When the tissue becomes inflamed, the disturbance of the equilibrium between the tissue and the blood so augments the resistance that the passage of the blood becomes difficult or impossible. And it is quite open to us to suppose that there are conditions the reverse of inflammation, in which the resistance may be lowered below the normal, and the circulation in the area quickened.

Such a diminution of peripheral resistance may possibly in part explain the remarkable quickening of the flow of blood, which is seen in any tissue after a temporary interruption of the stream, and which is also witnessed in the case of an artificial stream kept up in an organ such as the liver or kidney removed from the body. Mosso¹ by means of the *Plethysmograph*², determined that the amount of resistance offered to the artificial

¹ Ludwig's *Arbeiten*, 1874.

² By this instrument variations in volume are measured, and where these depend on variations in the quantity of blood passing the organ, which is being studied, changes

flow of blood through an excised kidney, depends upon the gases present in the blood passed through, the resistance being greater in proportion to the amount of carbonic acid irrespective of the quantity of oxygen.

Thus the vital condition of the tissue becomes a factor in the maintenance of the circulation.

It is perhaps hardly necessary to observe that the considerations urged above are quite distinct from what is sometimes spoken of under the name of 'capillary' force, as an agent of the circulation. If by capillary force it is intended to refer to the rise of fluids in capillary tubes, it is evident that since such phenomena are the results of adhesion, capillarity can only be a greater or less hindrance to the flow of blood, seeing that this is propelled by a force (the heart's beat) which has been proved by experiment to be equal to the task of driving the blood from ventricle to auricle through the capillary regions. If by capillary force it is meant that the tissues have some vital power of withdrawing the fluid parts of the blood from the small arteries and thus of assisting an onward flow, it becomes necessary also to assume that they have as well the power of returning the fluid parts to the veins. Both these assumptions are unnecessary and without foundation.

SEC. 7. CHANGES IN THE QUANTITY OF BLOOD.

In an artificial scheme, changes in the total quantity of fluid in circulation will have an immediate and direct effect on the arterial pressure, increase of the quantity heightening and decrease diminishing it. This effect will be produced partly by the pump being more or less filled at each stroke, and partly by the peripheral resistance being increased or diminished by the greater or less fullness of the capillaries. The venous pressure will under all circumstances be raised with the increase of fluid, but the arterial pressure will be raised in proportion only so long as the elastic walls of the arterial tubes are able to exert their elasticity.

In the natural circulation, the direct results of change of quantity are obscured by compensatory arrangements. Thus experiment shews¹ that when an animal with normal blood-pressure is bled from one carotid, the pressure in the other carotid sinks so long as the bleeding is going on (this of course not so much from loss of blood as from diminution of peripheral resistance in the open artery), and remains depressed for a brief period after the bleeding has ceased. In a short time however it regains or nearly regains the normal height. This recovery of blood-pressure, after hæmorrhage, is witnessed until the loss of blood amounts to about 3 per cent. of

in the circulation may thereby be investigated. Cf. Mosso, "Sopra un nuovo metodo per scrivere movimenti dei vasi sanguigni nell'uomo." *Atti. d. Real. Acad. d. Sci. d. Torino*, Vol. XI. François-Franck, Marey's *Travaux du Laborat.* Vol. II. p. 1, and the earlier memoir of Fick *Untersuch. Zürich. Physiol. Lab. Hft. I. p. 51.*

¹ Worm Müller, Ludwig's *Arbeiten*, 1873, p. 159. Lesser, *ibid.* 1874, p. 50.

the body-weight. Beyond that, a large and frequently a sudden dangerous permanent depression is observed.

The restoration of the pressure after the cessation of the bleeding is too rapid to permit us to suppose that the quantity of fluid in the blood-vessels is repaired by the withdrawal of lymph from the extra-vascular elements of the tissues. In all probability the result is gained by an increased action of the vaso-motor nerves, increasing the peripheral resistance, the vaso-motor centres being thrown into increased action by the diminution of their blood-supply. When the loss of blood has gone beyond a certain limit, this vaso-motor action is insufficient to compensate the diminished quantity, (possibly the vaso-motor centres in part become exhausted,) and a considerable depression takes place; but at this epoch the loss of blood frequently causes anæmic convulsions.

Similarly when an additional quantity of blood is injected into the vessels, no marked increase of blood-pressure is observed so long as the vaso-motor centre in the medulla oblongata is intact. If however the cervical spinal cord be divided previous to the injection, the pressure, which on account of the removal of the central vaso-motor action, is very low, is permanently raised by the injection of blood. At each injection the pressure rises, falls somewhat afterwards, but eventually remains at a higher level than before. This rise continues until the amount of blood in the vessels above the normal quantity reaches from 2 to 3 per cent. of the body-weight. Beyond this point there is no further rise of pressure.

These facts shew, in the first place, that when the volume of the blood is increased, compensation is effected by a lessening of the peripheral resistance by means of a diminished action of the vaso-motor centres, so that the normal blood-pressure remains constant. They further shew that a much greater quantity of blood can be lodged in the blood-vessels than is normally present in them. That the additional quantity injected does remain in the vessels is proved by the absence of extravasations, and of any considerable increase of the extra-vascular lymphatic fluids. It has already been insisted that the blood-vessels are, in health, but partially filled, that the veins and capillaries are alone able to receive all the blood in the body. In these cases of large addition of blood, the extra quantity appears to be lodged in the small veins and capillaries, (especially of the internal organs,) which are abnormally distended to contain the surplus.

We learn from these facts the two practical lessons, first, that blood-pressure cannot be lowered directly by bleeding, unless the quantity removed be dangerously large, and secondly, that there is no necessary connection between a high blood-pressure and fullness of blood or plethora, since an enormous quantity of blood may be driven into the vessels without any marked rise of pressure.

The Mutual Relations and the Coordination of the Vascular Factors.

The foregoing considerations shew how complicated, and sensitive, and therefore how useful, is the vascular mechanism. It may be worth while briefly to summarize the relations of the different factors, and to point out the manner in which they are made to work in harmony for the good of the body.

Two facts stand out prominent above all others: (1) the heart's beat may be made slow by vagus inhibition, and, probably, quickened by withdrawal of the constant inhibitory influence exercised by the cardio-inhibitory centre in the medulla. (2) The peripheral resistance may be diminished by diminished action (dilating action) of the vaso-motor centres, and increased by increased action (constricting action) of the same centres.

These two facts are, by the mediation of the nervous system, placed in mutual regulative dependence on each other. Thus, if with a given peripheral resistance, and proportionate blood-pressure, the heart begins to beat violently, afferent impulses passing up the depressor nerves diminish peripheral resistance (by opening the splanchnic flood-gates), and prevent the rise of blood-pressure which would otherwise take place. In this way, a delicate organ, such for instance as the retina, is sheltered from the turbulence of the heart by a change in the flow of blood through the less noble organs of the abdomen. Conversely, if peripheral resistance be in any area increased, the general blood-pressure is prevented from rising too high, by reason of the actual increase of blood-pressure so affecting the medulla, that inhibitory impulses descend the vagus, and, by producing a less frequent pulse, tone down the distension of the arteries.

The more we learn of the working of the body, the more aware we become of the fact that it is crowded with regulative and compensating arrangements no less striking and exquisite than the two we have just described. Some of these will be seen in the following almost tabular statement of the various modifications of the vascular factors, and of their causes.

A. *The Beat of the Heart* is affected

1. By the amount of **distension of the ventricular cavities** preceding the systole. This will depend on

a. The **quantity of blood** passing into the **ventricular cavities** during the diastole. This in turn is determined by the flow of blood through the veins, the flow itself being influenced by the arterial pressure, respiratory movements, &c. &c.

b. The **amount of resistance** which has to be overcome by the systole. This is determined by the mean arterial pressure, and is influenced by everything which influences that.

2. By the **quantity of the blood** passing through the **coronary arteries**. In the frog the thin walls of the auricle and the spongy texture of the ventricle permit the nourishment of the cardiac substance to be carried on by direct contact with the blood in the cavities. In mammals this mode of nutrition must be insignificant. In them the condition of the cardiac muscles and nervous appendages depends almost exclusively on the blood distributed by the coronary arteries. Putting aside the vaso-motor supply of the coronary arteries, of which we know nothing, we may say that the amount so sent will depend on the arterial pressure in the aorta.

If the blood-current through the muscles of the heart be intermittent, instead of constant as in other muscles, the beat of the heart must be itself self-regulative, and the whole matter becomes very complicated¹,

3. By the **quality of the blood** passing through the coronary arteries, and acting upon simply the muscular tissue, or upon the various nervous mechanisms, or upon both. This is well illustrated by the action of poisons (see p. 145). The quantitative relations of the normal, and the presence of abnormal, constituents must of necessity profoundly affect the heart's beat.

4. Through the **inhibitory fibres** of the vagus,

a. By the blood directly stimulating the **endings of the vagus fibres**. This is only seen in the case of poisons.

b. By the blood directly affecting the **cardio-inhibitory centre in the medulla oblongata**, either positively by augmenting the normal inhibitory influences, and so slowing the heart, or negatively by depressing those influences and so quickening the heart.

c. By **reflex stimulation** of the same centre. Cases of exaltation through reflex stimulation have already been quoted. Instances of depression leading to quickening of the heart's beat are not so clear. The afferent impulses may be started in any part of the body; but, as we have seen, there seems to be a special connection between this centre and the alimentary canal.

5. By the **accelerator nerves**. We have however no evidence of the natural activity of this nerve.

B. The *Peripheral Resistance* is affected

1. By the **vital i.e. the nutritive** condition of the **tissue** of the part. This is again influenced by

a. The **quality** (and quantity?) of the **blood** brought to it.

b. Through the agency of the **nervous system**, as in cases of inflammation caused by nervous influences.

Both these points are very obscure.

¹ Cf. Garrod, *Journ. Anat. and Phys.* VII. p. 219, VIII. p. 54.

2. By the **varying calibre** (constriction, dilation) of the **minute arteries**, brought about

a. By the blood or other stimulus acting directly on the **peripheral vaso-motor mechanism**,

b. By the blood acting directly on the **vaso-motor centre** in the medulla (or spinal cord).

c. By **reflex stimulation** of the vaso-motor centres.

d. It is more than probable that the peripheral resistance, *i. e.* the amount of constriction of the minute arteries, is directly dependent on the **blood-pressure** itself. In common with all muscles, the contraction of the circular muscles of the arteries will be greater when the resistance is greater, *i. e.* when the distension of the vessels is greater. That is to say, other things being equal, with an increase of pressure, due for instance to an increase of heart-beat, the distension so caused will be more than counterbalanced by the increased contraction of the muscular fibre, and thus the pressure still further increased. This of course will take place within certain limits only¹.

Through these intricate ties it comes to pass that an event which takes place in one part of the body is felt, to a greater or less extent, by all parts. To take a simple instance—a change in the condition of the skin at any one spot, such as that produced by the application of cold or heat, may lead,

1. By direct local action to a constriction or dilation of the vessels of the part, giving rise to local pallor or suffusion,

2. By reflex action through the vaso-motor centre,

a. to an increase of the same local effects, and in addition

b. to a change in the calibre of the blood-vessels in other parts. This distant reflex change may be of the same or the opposite nature as the local change.

3. By reflex action to a quickening or slowing of the heart's beat, though the heart is in this respect less intimately connected with the skin than with other parts.

Out of these primary effects there may arise secondary effects. The constriction or dilation produced locally will affect the general blood-pressure, which in turn will produce all its effects.

The modifications of the heart-beat will not only affect the general blood-pressure, but in a reflex manner may affect the peripheral resistance, and hence the flow of blood in particular areas (*e. g.* the splanchnic area). The modifications of the flow through the area directly, and also through those secondarily, affected, will influence the temperature and chemical changes of the blood, and those again will produce their effects everywhere. And so on.

¹ Cf. Latschenberger and Deahna, *Pflüger's Archiv*, XII. (1876) 157.

On the other hand, the turbulence which would be the natural outcome of all these events is softened down, by the compensating effects of which we have spoken, into the smoothness which we call health. Still the greatness of the possibilities of change which lie hidden in the body are clearly enough shewn by the violence of disease, when compensation fails of accomplishment.

The proofs of the circulation brought forward by Harvey (1628) required for their completion an explanation of the manner in which the blood passed from the small arteries to the small veins. For this the use of the microscope was necessary, and Malpighi (1661) was the first to demonstrate the capillary circulation. Leuwenhoek afterwards (1674) more fully described the passage of blood through the capillaries as seen in the web of the frog's foot, in the fin of the fish's tail, and in other transparent structures.

Observations on Blood-Pressure were first made by Dr Stephen Hales¹, who inserted a tall tube into the crural artery of a mare, and observed the height (more than eight feet) to which the column of blood rose. He thus used not a mercury, nor a water, but a blood, manometer. Poiseuille² introduced the mercury manometer, and to him we are indebted for our knowledge of the fundamental principles of the subject. The elaborate treatise of Volkmann³ helped to formulate our knowledge; and we are indebted to Ludwig for many of our present methods of investigation.

Claude Bernard⁴ was the first to observe that section of the cervical sympathetic on one side of the neck was followed by a rise of temperature and dilation of the blood-vessels of the same side of the head. Brown-Séguard in the same year⁵ was apparently the first to observe that stimulation of the peripheral portion of the divided sympathetic brought about a return of the pallor and a fall of temperature; he clearly recognised that the effects of the section of the sympathetic were the results of a paralysis of the blood-vessels. Bernard himself, somewhat later⁶, observed the effects of galvanic stimulation of the divided nerve, though he seems not to have obtained so distinct a grasp of the matter as did A. Waller⁷, who in Feb. 1853 clearly recognised the vaso-motorial functions of the cervical sympathetic, and the relation of these functions to the action of the same nerve on the iris. These discoveries formed the beginning of our knowledge of the vaso-motor nerves. Among the numerous investigations which have since been carried on, none can be considered more important than those for which we are indebted to Ludwig and his pupils.

¹ *Statical Essays*, Vol. II. (1732).

² *Rech. s. l. Causes du Mouvement du Sang*, 1831.

³ *Hämodynamik*, 1850.

⁴ *Comptes Rendus*, xxxiv. (1852) p. 472.

⁵ *Philadelphia Medical Examiner*, Aug. 1852, p. 489, quoted in *Experimental Researches applied to Physiology and Pathology*, New York. 1853, p. 9.

⁶ *Comptes Rendus de la Société de Biologie*, Nov. 1852.

⁷ *Comptes Rendus*, xxxvi. (1853) p. 378.

BOOK II.

THE TISSUES OF CHEMICAL ACTION WITH THEIR
RESPECTIVE MECHANISMS. NUTRITION.

CHAPTER I.

THE TISSUES AND MECHANISMS OF DIGESTION.

THE food in passing along the alimentary canal is subjected to the action of certain juices which are the products of the secretory activity of the epithelium-cells of the alimentary mucous membrane itself, or of the glands which belong to it. These juices (viz. saliva, gastric juice, bile, pancreatic juice, succus entericus, and the secretion of the large intestine), poured upon and mingling with the food, produce in it such changes, that from being largely insoluble it becomes largely soluble, or otherwise modify it in such a way that the larger part of what is eaten passes into the blood, either directly by means of the capillaries of the alimentary canal or indirectly by means of the lacteal system, while the smaller part is discharged as excrement.

We have therefore to consider—1st, the properties of the various juices, and the changes they bring about in the food eaten. 2nd, the nature of the processes by means of which the various epithelium-cells of the various glands and various tracts of the canal are able to manufacture so many various juices out of the common source, the blood, and the manner in which the secretory activity of the cells is regulated and subjected to the needs of the economy. 3rd, the mechanisms, here as elsewhere chiefly of a muscular nature, by which the food is passed along the canal, and most efficiently brought in contact with successive juices. And 4th and lastly, the means by which the nutritious digested material is separated from the indigested or excremental material, and insorbed into the blood.

SEC. 1. THE PROPERTIES OF THE DIGESTIVE JUICES.

Saliva.

Mixed saliva, as it appears in the mouth, is a thick, glairy, generally frothy and turbid fluid. Under the microscope it is seen to contain, besides the molecular debris of food (and frequently cryptogamic spores), epithelium-scales, mucus-corpuscles and granules, and the so-called salivary corpuscles. Its reaction in a healthy subject is alkaline, especially when the secretion is abundant. When

the saliva is scanty, or when the subject suffers from dyspepsia, the reaction of the mouth may be acid. Saliva contains but few solids, .484 p. c. in man, giving a specific gravity of 1.0023. Of these solids, about half, .188, are salts (including a small quantity of potassium sulphocyanate). The organic bodies which can be recognised in it are chiefly mucin, with small quantities of globulin and serum-albumin.

The chief purpose served by the saliva in digestion is to moisten the food, and to assist in mastication and deglutition. In some animals this is its only function. In other animals and in man it has a specific solvent action on some of the food-stuffs. Such minerals as are soluble in slightly alkaline fluids are dissolved by it. On fats it has no effect save that of producing a very feeble emulsion. On proteids it has also no action. Its characteristic property is that of converting starch into grape-sugar.

Action of Saliva on Starch. If to a quantity of thin boiled starch, which has been ascertained to be free from sugar, a small quantity of saliva be added, it will be found after a time that the whole of the starch has disappeared, having been replaced by a corresponding quantity of grape-sugar. The mixture no longer gives any blue colour with iodine, but when boiled with Fehling's fluid (cupric sulphate dissolved in a concentrated solution of sodium hydrate, in the presence of sodium-potassium tartrate), gives a copious red or yellow deposit of cuprous oxide. Examined quantitatively, it will be found that the amount of sugar which has been formed is the equivalent of the starch which has disappeared, that is, the starch has by the action of the saliva been converted into sugar. If iodine be added to the mixture in the early stages of the action of the saliva, a red or violet colour (more or less obscured by the blue) will be observed. This indicates the presence of *dextrin*, which at a later stage, like the starch itself, disappears. In fact, the saliva either converts the starch into dextrin and then into sugar, or first splits the starch into dextrin and sugar, and then changes the dextrin into sugar. The essence of both changes is the assumption of a molecule of water. Thus starch, $C_6H_{10}O_5$, or more probably

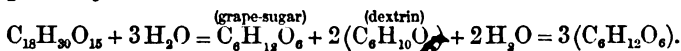

While boiled starch is thus converted into grape-sugar with considerable rapidity, raw unboiled starch also suffers the same change, though more slowly. If a quantity of raw starch be suspended in water and saliva be added, the water will after a time be found to contain sugar. If the water be replaced from time to time, the starch will gradually disappear until a remnant is left which gives no blue colour with iodine, unless acid be previously added. The starch-corpuscle consists of *granulose* giving a blue colour with iodine alone, and *cellulose* giving a blue colour with iodine on the addition of sulphuric acid. The saliva acts on the granulose, converting it into sugar; it is unable to act on the cellulose. When starch

is boiled, the cellulose coats of the starch-corpuscle are ruptured and the saliva has ready access to the granulose. Hence the rapidity of the action. In raw starch the saliva can only get at the granulose by traversing the coat of cellulose.

Brücke¹ distinguishes in the starch-corpuscle, besides granulose and cellulose, a third body which he calls *erythrogranulose*. This gives a red, not a blue colour with iodine, not usually seen when iodine is added to starch, because erythrogranulose is much less abundant than ordinary granulose. Erythrogranulose is converted by saliva into grape-sugar, but not so readily as granulose. Brücke further regards dextrin resulting from the conversion of starch as a mixture of *erythro-dextrin* giving a red colour with iodine, and *achroo-dextrin* which is not coloured by iodine. The former is readily converted by saliva and similar agents into grape-sugar, the latter with considerable difficulty; so that a fluid originally containing starch, after it has been acted upon by saliva until iodine gives no longer either a blue or red colour, may still contain a considerable quantity of dextrin in the form of achroo-dextrin. When starch is acted upon by dilute acids, the conversion into dextrin is preceded by the appearance of *soluble starch*, i.e. of starch which like dextrin forms a clear solution with water but unlike dextrin gives a blue colour with iodine. Thus starting from granulose and erythrogranulose, the end product of grape-sugar may be reached through the intermediate stages of soluble starch or *amidulin*, erythro-dextrin, and achroo-dextrin.

The conversion of starch into sugar, or the amylolytic action of saliva, will go on at the ordinary temperature of the atmosphere. The lower the temperature, the slower the change, and at about 0° C. the conversion is indefinitely prolonged. After exposure to cold of even as much as some degrees below 0°, when the temperature is again raised the action recommences. Increase of temperature up to about 35°—40°, or even higher, favours the change. Beyond 60° or 70° increase of temperature is injurious, and saliva which has been boiled for a few minutes not only has no action on starch while at that temperature, but does not regain its powers on cooling. By being boiled, the amylolytic activity of saliva is permanently destroyed.

The action of saliva on starch is favoured by a slightly alkaline medium. It will, however, still go on even in the presence of a small quantity of free acid. Increase of acidity, however, checks it. Thus in a mixture containing 1 per cent. of free hydrochloric acid, the conversion of starch is arrested. After a short exposure to a dilute acid, saliva will regain its powers on neutralisation. Its activity is, however, permanently destroyed by long exposure to weak, or by shorter exposure to strong, acids. Strong alkalies also destroy it.

The action of saliva is hampered by the concentrated presence of the product of its own action, that is, of sugar. If a small quantity of saliva be added to a thick mass of boiled starch, the action will after a while slacken, and eventually come to almost a stand-still long before all the starch has been converted. On diluting the mixture

¹ *Vorlesungen*, i. p. 221.

with water, the action will recommence. If the products of action be removed as soon as they are formed, a small quantity of saliva will, if sufficient time be allowed, convert into sugar a very large, one might almost say an indefinite, quantity of starch.

It is at present uncertain whether the constituent of the saliva, on which its activity depends, is at all consumed in its action. Paschutin¹ argues that it is; but other observers have come to a contrary conclusion.

On what constituent do the amyolytic virtues of saliva depend?

If saliva, filtered and thus freed from mucus and the formed constituents, be treated with ten or fifteen times its bulk of alcohol, a precipitate containing all the proteid matters takes place. Upon standing under the alcohol for some time (several days, or, better, weeks), the proteids thus precipitated become coagulated and insoluble in water. Hence, an aqueous extract of the precipitate, made after this interval, contains little or no proteid material. Yet it is as active, or almost as active, as the original saliva (the solution being brought to the same bulk as the saliva). If the precipitate be treated with concentrated glycerine, very little passes into solution. Nevertheless, the glycerine, diluted with water, is found to be highly amyolytic. Now we cannot say that even this small quantity of matter which is thus soluble in glycerine is entirely composed of the really active constituent; it may be and probably is a mixture of this with other bodies. An amyolytic solution, free from proteid matter, may also be prepared by Brücke's method for isolating pepsin (see p. 193); but this also probably contains other bodies beside the really active constituent; whatever the active substance be in itself, it exists in such extremely small quantities, that it has never yet been satisfactorily isolated; and indeed the only evidence we have of its existence is the manifestation of its peculiar powers.

The salient features of this body, which we may call *ptyalin*, are then 1st, its presence in minute and almost inappreciable quantity; 2nd, the close dependence of its activity on temperature; 3rd, its permanent and total destruction by a high temperature and by chemical reagents such as a strong acid; 4th, the want of any clear proof that it itself undergoes any change during the manifestation of its powers; that is to say, the energy necessary for the transformation which it effects *does not come out of itself*. If it is at all used up in its action, the loss is rather that of simple wear and tear of a machine, than that of a substance expended to do work; 5th, the action which it induces is of such a kind (splitting up of a molecule with assumption of water) as is effected by the agents called catalytic, and by that particular class of catalytic agents called hydrolytic.

These features mark out the amyolytic active body of saliva as belonging to the class of *ferments*²; and we may henceforward speak of the amyolytic ferment of saliva.

¹ *Centrbt. f. Med. Wissen.*, 1871.

² Ferments may, for the present at least, be divided into two classes, commonly called *organised* and *unorganised*. Of the former, yeast may be taken as a well-known

Mixed saliva, whose properties we have just discussed, is the result of the mingling in various proportions of saliva from the parotid, submaxillary, and sublingual glands with the secretion from the buccal glands.

Parotid saliva, as obtained by introducing a cannula into the Stenonian duct, is clear and limpid, not viscid. On standing, it becomes turbid from a precipitate of calcic carbonate, due to an escape of carbonic acid. It contains globulin and some other forms of albumin, with little or no mucin. Potassium sulphocyanate is present, but structural elements are absent. In man, at least, it acts powerfully on starch.

Submaxillary saliva, as obtained by introducing a cannula into the duct of Wharton, differs from parotid saliva in being more alkaline and, from the presence of mucus, more viscid; it contains, often in abundance, salivary corpuscles, and amorphous masses of proteid material. The so-called *chorda saliva* in the dog (see Sec. 2) is under ordinary circumstances thinner and less viscid, contains less mucus, and fewer structural elements, than the so-called *sympathetic saliva*, which is remarkable for its viscosity, its structural elements, and for its larger total of solids.

In man, submaxillary saliva acts more powerfully on starch than parotid saliva, and in animals whose saliva is active on starch, the activity is found in the submaxillary saliva at least. In the dog, sublingual saliva is more viscid, and contains more mucin and more total solids than even the submaxillary saliva.

The action of saliva varies in intensity in different animals.

Thus in man, the pig, the rabbit, the guinea-pig, and the rat, both parotid and submaxillary and mixed saliva are amyolytic. In the dog, parotid saliva is wholly inert on starch, submaxillary and mixed saliva have a slight effect only; the saliva of the cat is more active than that of the dog. In the horse, sheep, and ox, the amyolytic powers of either mixed saliva, or of any one of the constituent juices, are extremely feeble.

Where the saliva of any gland is active, an aqueous infusion of the same gland is also active. The importance and bearing of this statement will be seen later on. From the aqueous infusion of the gland, as from saliva itself, the ferment may be approximately isolated.

In some cases at least a ferment may be extracted from the gland even when the secretion is itself inactive.

The readiest method indeed of preparing a highly amyolytic liquid as free as possible from proteid and other impurities, is to mince the gland finely, dehydrate it by allowing it to stand under absolute alcohol for some days, and then, having poured off most of the alcohol, and removed the remainder by evaporation at a low tem-

example. The fermentative activity of yeast which leads to the conversion of sugar into alcohol, is dependent on the life of the yeast-cell. Unless the yeast-cell be living and functional, fermentation does not take place; when the yeast-cell dies fermentation ceases; and no substance obtained from yeast, by precipitation with alcohol or otherwise, will give rise to alcoholic fermentation. The salivary ferment belongs to the latter class; it is a substance, not a living organism like yeast.

perature, to cover the pieces of gland with strong glycerine. A mere drop of such a glycerine extract rapidly converts starch into grape-sugar.

Gastric Juice.

Gastric juice, obtained by artificial stimulation from the healthy stomach of a fasting dog, by means of a gastric fistula, is a thin almost colourless fluid with a sour taste and odour.

In the operation for gastric fistula, an incision is made through the abdominal walls, along the *linea alba*, the stomach is opened, and the lips of the gastric wound securely sewn to those of the incision in the abdominal walls. Union soon takes place, so that a permanent opening from the exterior into the inside of the stomach is established. A tube of proper construction, introduced at the time of the operation, becomes firmly secured in place by the contraction of healing. Through the tube the contents of the stomach can be received, and the mucous membrane stimulated at pleasure.

When obtained from a natural fistula in man, its specific gravity has been found to differ little from that of water, varying from 1·001 to 1·010, and the amount of solids present to be very small, viz. about ·56 per cent.

In the dog however the amount of solids is as much as 2·7 per cent., and in the sheep 1·9¹; and the estimate given above for man probably does not represent a thoroughly healthy juice.

Of these about half, ·24, are inorganic salts, chiefly alkaline (sodium) chloride, with small quantities of phosphates. The organic material consists chiefly of peptone, other forms of proteids being absent. In a healthy stomach gastric juice is free from mucus, unless some submaxillary saliva has been swallowed.

The reaction is distinctly acid, and the acidity is normally due to free hydrochloric acid. This is proved by the fact that the amount of hydrochloric acid is more than can be neutralized by the bases, and this excess corresponds to the quantity of free acid present². Lactic and butyric and other acids when present are secondary products, arising either by their respective fermentations from articles of food, or from decomposition of their alkaline or other salts. In man the amount of free hydrochloric acid in juice having the above specific gravity was found to be ·02 per cent.

This is probably below the normal of health, since in the dog Bidder and Schmidt³ found free acid to the extent of ·3 per cent., and in the sheep ·123 per cent. As will be mentioned below, a free acidity of ·2 per cent. is most efficacious in artificial digestion, and in all probability good healthy human gastric juice possesses an acidity not far from this.

¹ Bidder u. Schmidt, *Die Verdauungssäfte*, s. 73.

² Bidder u. Schmidt, *op. cit.*

³ *Op. cit.*

On starch gastric juice has *per se* no effect whatever; indeed the acidity of the juice tends to weaken, and sometimes appears to be sufficient to arrest the amylolytic action of any saliva with which it may be mixed.

On grape-sugar and cane-sugar healthy gastric juice has no effect.

When the stomach contains mucus, gastric juice has the power of converting cane-sugar into grape-sugar. This power seems to be due to presence in the mucus of a special ferment, analogous to, but quite distinct from, the ptyalin of saliva. An excessive quantity of cane-sugar introduced into the stomach causes a secretion of mucus, and hence provides for its own conversion.

On fats gastric juice is powerless. They undergo by reason of it no change whatever in themselves. When adipose tissue is eaten, all that happens in the stomach is that the proteid and gelatiniferous envelopes of the fat-cells are dissolved, and the fats set free; the fat itself undergoes no change except the very slightest emulsion.

Such minerals as are soluble in free hydrochloric acid are for the most part dissolved; though there is a difference in this respect between gastric juice and simple free hydrochloric acid diluted with water to the same degree of acidity as the juice.

The essential property of gastric juice is the power of dissolving proteid matters, and of converting them into a substance called peptone.

Action of gastric juice on proteids. The results are essentially the same whether natural juice obtained by means of a fistula or artificial juice, *i.e.* an acid infusion of the mucous membrane of the stomach, be used.

Artificial gastric juice may be prepared in any of the following ways.

1. By scraping the surface of a (pig's or dog's) stomach, rubbing up the scrapings with pounded glass and water in a mortar, filtering, and adding hydrochloric acid, till the filtrate, which is in itself somewhat acid, has a free acidity corresponding to .2 p. c. of hydrochloric acid. The juice thus prepared contains but little peptone, but is not very potent.

2. By removing the mucous membrane from the muscular coat, mincing the former finely, and allowing it to digest at 35° C. in a large quantity of hydrochloric acid diluted to .2 p. c. The greater part of the membrane disappears, shreds only being left, and the somewhat opalescent liquid can be decanted and filtered. The filtrate has powerful digestive (peptic) properties, but contains a considerable amount of the products of digestion (peptone, &c.), arising from the mucous membrane digesting itself¹.

3. From the mucous membrane, similarly prepared and minced, the superfluous moisture is removed with blotting paper, and the pieces are thrown into a comparatively large quantity of concentrated glycerine, and allowed to stand. The membrane may be previously dehydrated by being

¹ These however may be removed by concentration at 40° C., and subsequent dialysis.

allowed to stand under alcohol, but this is not necessary. The decanted clear glycerine in which scarcely any of the ordinary proteids of the mucous membrane are dissolved, if added to hydrochloric acid of .2 p. c. (a few drops of glycerine to 100 cc. of the dilute acid are sufficient), makes an artificial juice free from ordinary proteids and peptone, and of remarkable potency, the presence of the glycerine not interfering with the results.

If a few shreds of fibrin, obtained by whipping blood, after being thoroughly washed and boiled, be thrown into a quantity of gastric juice, and the mixture exposed to a temperature of from 35° to 40° C., the fibrin will speedily, in some cases in a few minutes, be dissolved. The shreds first swell up and become transparent, then fall to pieces into flakes especially when the vessel containing them is shaken, and finally disappear with the exception of a little granular debris, the amount of which varies according to circumstances.

If small morsels of coagulated albumin, such as white of egg, be treated in the same way, the same solution is observed. The pieces become transparent at their surfaces; this is especially seen at the edges, which gradually become rounded down; and solution steadily progresses from the outside of the pieces inwards.

If any other form of coagulated albumin, (*e.g.* precipitated acid or alkali albumin, suspended in water and boiled) be treated in the same way, a similar solution takes place. The readiness with which the solution is effected, will depend, *ceteris paribus*, on the smallness of the pieces, or rather on the amount of surface as compared with bulk, which is presented to the action of the juice.

Gastric juice then readily dissolves coagulated proteids, which otherwise are insoluble, or soluble only, and that with difficulty, in very strong acids.

Nature of the change as shown by the products of the action.

If raw white of egg, largely diluted with water and strained, be treated with a sufficient quantity of dilute hydrochloric acid, the opalescence or turbidity which appeared in the white of egg on dilution, and which is due to the precipitation of various forms of globulin, disappears, and a clear mixture results. If a portion of the mixture be at once boiled, a large deposit of coagulated albumin occurs. If, however, the mixture be exposed to 35° or 40° C. for some time, the amount of coagulation which is produced by boiling a specimen becomes less, and, finally, boiling produces no coagulation whatever. By neutralisation, however, the whole of the albumin (with such restrictions as the presence of certain neutral salts may cause) may be obtained in the form of acid-albumin or syntonin, the filtrate after neutralisation containing no proteids at all (or a very small quantity). Thus the whole of the albumin present in the white of egg is converted, by the simple action of dilute hydrochloric acid, into acid-albumin or syntonin.

If the same white of egg be treated with gastric juice instead of simple dilute hydrochloric acid, the events for some time seem the

same. Thus after a while boiling causes no coagulation, while neutralisation gives a considerable precipitate of a proteid body, which, being insoluble in water, and in dilute sodium chloride solutions, and soluble in dilute alkali and acids, at least closely resembles syntonin. But it is found that only a portion of the proteids originally present in the white of egg can thus be regained by precipitation. A great deal is still retained in the filtrate after neutralisation, in the form of what is called *peptone*, and, on the whole, the longer the digestion is carried on, the greater is the proportion borne by the peptone to the precipitate thrown down on neutralisation; indeed, in some cases at all events, all the proteids are brought into the condition of peptone.

Peptone is a proteid, having the same approximate elementary composition as other proteids, and giving most of the usual proteid reactions.

It is distinguished from other proteids by the following marked features:

1st. It is not precipitated by potassium ferrocyanide and acetic acid, as are all other proteids.

2nd. Though soluble in distilled water and in neutral saline solutions, even the most dilute, and therefore not precipitated from its acid or alkaline solutions by neutralisation, it is not coagulated by heat.

3rd. It is highly diffusible, passing through membranes with the greatest ease. (For the other less important reactions see Appendix.)

The neutralisation precipitate resembles, in its general characters, acid-albumin or syntonin. Since, however, it probably is distinguishable from the body or bodies produced by the action of simple acid on muscle or white of egg, it is best to reserve for it the name of *parapeptone*. Thus the digestion by gastric juice of white of egg results in the conversion of all the proteids present into peptone and parapeptone, of which the former must be considered as the final and chief product, the latter a bye product or initial product of variable occurrence and importance. The gastric digestion of fibrin, either raw or boiled, and of all forms of coagulated albumin, gives rise to the same products, peptone and parapeptone. Milk when treated with gastric juice is first of all coagulated or curdled. This is the result partly of the action of the free acid and partly of the special action of a particular constituent of gastric juice, of which we shall speak hereafter. The coagulated milk is subsequently dissolved with the same appearance of peptone and parapeptone as in the case of other proteids. In fact the digestion by gastric juice of all the varieties of proteids consists in the conversion of the proteid into peptone, with the concomitant appearance of a certain variable amount of parapeptone.

When raw unboiled fibrin is treated with gastric juice, the digesting mixture is found, when examined immediately after the solution of the fibrin, to contain, in addition to peptone and parapeptone, soluble albumin coagulable by heat. No such soluble albumin is formed during the digestion of boiled fibrin or of any form of coagulated albumin.

Circumstances affecting gastric digestion. In order to come to a satisfactory conclusion on this matter, it is desirable to use the same proteid in all the experiments; and of all proteids, boiled fibrin is most convenient. It should be boiled rather than raw, because the latter is, for reasons of which we shall speak presently, soluble to a certain extent in dilute acids alone. Since, as will be seen, a given amount of gastric juice may by proper management be made to digest an almost indefinite quantity of fibrin if sufficient time be allowed, we are obliged to take, as a measure of the activity of a specimen of gastric juice, the rapidity with which it dissolves a given quantity of fibrin.

The greater the surface presented to the action of the juice, the more rapid the solution. Hence minute division and constant movement favour digestion. Neutralisation of the juice wholly arrests digestion. Fibrin may be submitted for an almost indefinite time to the action of neutralised gastric juice without being digested. If the neutralised juice be again properly acidified, it becomes quite as active as before. Digestion is most rapid with dilute hydrochloric acid of .2 p. c. (the acidity of natural gastric juice). If the juice contains much more or much less free acid than this, its activity is visibly impaired. Other acids, lactic, phosphoric, &c. may be substituted for hydrochloric; but they are not so effectual, and the degree of acidity most useful varies with the different acids. The presence of neutral salts, especially sodium chloride, in excess is injurious¹. The presence in a concentrated form of the products of digestion hinders the process. If a large quantity of fibrin be placed in a small quantity of juice, digestion is soon arrested; on dilution with the normal hydrochloric acid (.2 p. c.), or if the mixture be submitted to dialysis, and its acidity be kept up to the normal, the action recommences. Digestion is most rapid at about 35°—40° C.; at the ordinary temperature it is much slower, and at about 0° C. ceases altogether. Gastric juice may be kept however at 0° C. for an indefinite period without injury to its powers.

The gastric juice of cold-blooded animals is relatively more active at low temperatures than that of warm-blooded animals; whether this is due to a different nature of the gastric juice, or to attendant circumstances, is uncertain². The digestive fluid obtained from the stomach of the crab seems to be akin to pancreatic rather than to gastric juice³.

At temperatures much above 40° or 45° the action of the

¹ A. Schmidt, *Pflüger's Archiv*, xiii. (1876), p. 93.

² Fick, *Arbeiten Physiol. Lab. Würz.* II. (1873) s. 181.

³ Hoppe-Seyler, *Pflüger's Archiv*, xiv. (1877), 395.

juice is impaired. By boiling for a few minutes the activity of the most powerful juice is irrevocably destroyed. By removing the products of digestion as fast as they are formed, and by keeping up the acidity to the normal, a given amount of gastric juice may be made to digest an almost unlimited quantity of proteid. This shews that the energies of the juice are not exhausted by the act of digestion.

It has been debated whether this statement is absolutely true. Dr Ransome¹, however, thinks that the powers of the juice are even increased by action.

Nature of the action. All these facts go to show that the digestive action of gastric juice on proteids, like that of saliva on starch, is a ferment-action; in other words, that the solvent action of gastric juice is essentially due to the presence in it of a ferment-body. To this ferment-body, which as yet has been only approximately isolated, the name of *pepsin* has been given. The glycerine extract of mucous membrane, especially of that which has been dehydrated, contains a minimal quantity of proteid matter, and yet is intensely active. The elaborate method of Brücke gives us a residue which possesses none of the ordinary proteid reactions, and yet in concert with normal dilute hydrochloric acid is peptic in the highest degree. We may therefore safely assert that pepsin is not a proteid. Brücke's residue contained nitrogen, but it would be hazardous to assert that that residue was nothing but pepsin. At present the manifestation of peptic powers is our only test of the presence of pepsin.

Brücke's² method is as follows. Gastric mucous membrane is digested with dilute phosphoric instead of hydrochloric acid. To the filtered digest clear lime-water is added, until a violet reaction with litmus is gained. The bulky precipitate of calcium phosphate carries down with it mechanically the greater part of the pepsin; the supernatant fluid when reacidified has very little peptic power. The precipitate is collected, pressed, suspended in water, and redissolved carefully, with a minimal quantity of dilute hydrochloric acid, and reprecipitated with lime-water; much of the peptone which went down with the first precipitate is thus left behind, while the pepsin still clings to the calcic salt. The precipitate is again dissolved in dilute hydrochloric acid, placed in a flask, and a solution of cholesterin in 4 parts alcohol to 1 ether is poured in slowly, through a long funnel reaching to the bottom of the flask. The cholesterin rises as a bulky mass to the top of the liquid, carrying the pepsin with it. After several shakings the cholesterin is collected, washed with water acidulated with acetic acid, and then with pure water. While still moist, it is transferred to a vessel and shaken with alcohol-free ether, which, dissolving the cholesterin and floating on the top, leaves a watery stratum below. This must be repeated until all the cholesterin is dissolved. The ether is removed, and the watery residue is filtered. The filtrate, though it does not give the ordinary reactions of proteids, is, when acidulated, most

¹ *Journ. Anat. Phys.* (1876), Vol. x.

² Moleschott's *Untersuch.* vi. (1859), s. 479.

strongly peptic. By dialysis it may be still further purified (for pepsin will not pass through ordinary dialysis paper); but even the dialysed fluid gives a precipitate with basic and neutral lead-acetate.

In one important respect pepsin, the ferment of gastric juice, differs from ptyalin, the ferment of saliva. Though saliva is most active in a faintly alkaline medium, there seems to be no special connection between the ferment and any alkali. In gastric juice, however, there is a strong tie between the acid and the ferment, so strong that some writers speak of pepsin and hydrochloric acid as forming together a compound, pepto-hydrochloric acid.

In the absence of exact knowledge of the constitution of proteids, we cannot state distinctly what is the precise nature of the change into peptone. Judging from the analogy with the action of saliva on starch, we may fairly suppose that the process is at bottom one of hydration. Peptone closely resembling, if not identical with, that obtained by gastric digestion, may be obtained by the action of strong acids, by the prolonged action of dilute acids especially at high temperature, or simply by digestion with super-heated water in a Papin's digester. The *role* of pepsin therefore is only to facilitate a change which may be effected without it. Since, in the act of digestion, the pepsin itself is not exhausted, it is clear that the energy which is spent in the conversion of the proteid into peptone does not come from the ferment.

We have seen that a particular acid and a particular dilution are most favourable to digestion. We may add, that the natural action of the acid is modified by the presence of the pepsin. It is not that in digestion the acid converts the proteid into acid-albumin, which, in turn, is converted by the pepsin into peptone. Ordinary albumin is less readily converted into neutralisation products when pepsin is present, than when pepsin is absent, and, as we shall see, the neutralisation products probably differ also in nature in the two cases. When bones are treated with simple hydrochloric acid, the earthy salts are dissolved out, and the animal basis left; when bones are treated with gastric juice, the animal basis is acted on more speedily than the earthy salts¹. The nature of peptic digestion will however be more fully discussed under pancreatic digestion.

All proteids, as far as we know, are converted by pepsin into peptone. Of its action on other nitrogenous substances not truly proteid in nature, we need only say that mucin, nuclein, and the chemical basis of horny tissues are wholly unaffected by it, but that the gelatiniferous tissues are dissolved and changed into a substance so far analogous with peptone, that the characteristic property of gelatinisation is entirely lost.

Chondrin and the elastic tissues are also dissolved².

Milk is peculiarly affected by gastric juice, whether natural or artificial. It is curdled, that is to say, its casein is precipitated. The

¹ Kühne, *Lehrb.* t. 40.

² Etzinger, *Zt. f. Biolog.* x. (1874), 84.

change will go on at the ordinary temperature, but is favoured by that of 35°—40°. This property of gastric juice (which has long been known in domestic life, the *rennet* used for the purpose of curdling milk in the manufacture of cheese, or for other purposes, being an infusion of calves' stomach) does not depend on the acidity of the juice, *i.e.* the casein is not directly precipitated by the free acid of the juice; for neutralized gastric juice is efficacious. Since the property is lost when the neutralized juice is boiled, and the effects are so closely dependent on temperature, it seems probable—and the conclusion is supported by other facts—that a special ferment is present in the juice, which, by converting the milk-sugar into lactic acid, precipitates the casein. This ferment is not identical with pepsin, for though the ordinary glycerine extract of mucous membrane is active, Brücke's pepsin is powerless in this direction.

Bile.

The quality of bile varies much, not only in different animals, but in the same animal at different times. It is moreover affected by the length of the sojourn in the gall-bladder; bile taken direct from the hepatic duct, especially when secreted rapidly, contains little or no mucus; that taken from the gall-bladder, as of slaughtered oxen or sheep, is loaded with mucus. The colour of the bile of carnivorous and omnivorous animals, and of man, is a bright golden red: of graminivorous animals, a golden green, or a bright green, or a dirty green, according to circumstances, being much modified by retention in the gall-bladder. The reaction is alkaline. The following may be taken as the average composition of human bile (Frerichs).

	In 1000 parts.					
Water	859·2
Solids:—						
Bile Salts	91·4
Fats, &c.	9·2
Cholesterin	2·6
Mucus and Pigment	29·8
Inorganic Salts	7·8

140·8

Bile therefore is distinguished from the other alimentary secretions by the entire absence of proteids. With regard to the inorganic salts, the points of interest are the presence of a large quantity of sodium chloride (·2 to ·27 per cent.), the presence of phosphates, and of iron and manganese, and occasionally, at all events, of copper. The ash contains soda in a very large amount, and also sulphates, both coming from the bile-salts. The constituents which deserve chief attention are the pigments and the bile-salts.

Pigments of Bile. The natural golden red colour of normal human or carnivorous bile, is due to the presence of *Bilirubin*. This,

which is also the chief pigmentary constituent of gall-stones, and occurs largely in the urine of jaundice, may be obtained in the form either of an orange-coloured powder, or of well-formed rhombic tablets and prisms. Insoluble in water, and but little soluble in ether and alcohol, it is readily soluble in chloroform, and in alkaline fluids. Its composition is $C_{18}H_{18}N_2O_5$. Treated with oxidizing agents, such as nitric acid yellow with nitrous acid, it displays a succession of colours in order of the spectrum. The yellowish golden red becomes green, this a greenish blue, then blue, next violet, afterwards a dirty red, and finally a pale yellow. This characteristic reaction of bilirubin is the basis of the so-called Gmelin's test for bile-pigments. Each of these stages represents a distinct pigmentary substance. An alkaline solution of bilirubin, exposed in a shallow vessel to the action of the air, turns green, becoming converted into *Biliverdin* ($C_{16}H_{20}N_2O_5$ or $C_{14}H_{14}N_2O_4$, Maly), the green pigment of herbivorous bile. Biliverdin is also found in the edges of the placenta of the bitch, and at times in the urine of jaundice, and is probably the body which gives to bile which has been exposed to the action of gastric juice, as in biliary vomits, its characteristic green hue. It is the first stage of the oxidation of bilirubin in Gmelin's test. Treated with oxidizing agents biliverdin runs through the same series of colours as bilirubin, with the exception of the initial golden red.

We have already discussed, p. 30, the relation of bilirubin to hæmatoidin. Other pigments, *bilifuscin*, *biliprasin*, have been found in small quantities in gall-stones.

Fresh normal bile, either of man, the cow, the pig or dog, exhibits no absorption-bands, though these make their appearance in the alcoholic extracts, and when the bile has become altered.

When bilirubin has been oxidized down to the last (yellowish) stage in Gmelin's test, the liquid is found to contain a body with characteristic absorption-bands. To this the name of *choletelin* has been given. Bilirubin treated, on the other hand, with reducing agents (sodium amalgam) is converted into a body called *urobilin* (hydrobilirubin), also with characteristic spectrum appearances. The latter body is of interest, since it occurs frequently in urine, especially that of fever patients¹.

The bile-salts. These consist, in man and many animals, of *sodium glycocholate* and *taurocholate*: the proportion of the two varying in different animals. In ox-gall, sodium glycocholate is abundant, and taurocholate scanty. Human bile-salts consist chiefly of sodium taurocholate, there being only a small quantity of sodium glycocholate; those of the dog, cat, bear, and other carnivora, consist exclusively of the former, the latter being entirely absent.

In the bile of the pig two peculiar acids are present, in union with sodium, viz., glychoyocholic and taurohyocholic, differing however but slightly from the above. Similarly, the bile of the goose contains taurochenocholic acid.

¹ Compare Jaffe, *Virch. Archiv*, 47, 405; Heynsius and Campbell, *Pflüger's Archiv*, iv. 497, x. 246; Liebermann, *Pflüger's Archiv*, xi. 182.

Insoluble in ether but soluble in alcohol and in water, the aqueous solutions having a decided alkaline reaction, both salts may be obtained by crystallisation in fine acicular needles. They are exceedingly deliquescent. The solutions of both acids have a dextro-rotatory action on polarized light.

Preparation. Bile, mixed with animal charcoal, is evaporated to dryness and extracted with alcohol. If not colourless, the alcoholic filtrate must be further decolorized with animal charcoal, and the alcohol distilled off. The dry residue is treated with absolute alcohol, and to the alcoholic filtrate anhydrous ether is added as long as any precipitate is formed. On standing the cloudy precipitate becomes transformed into a crystalline mass at the bottom of the vessel. If the alcohol be not absolute, the crystals are very apt to be changed into a thick syrupy fluid. This mass of crystals has been often spoken of as *bilin*. Both salts are thus precipitated, so that in such a bile as that of the ox or man *bilin* consists both of sodium glycocholate and sodium taurocholate. The two may be separated by precipitation from their aqueous solutions with sugar of lead, which throws down the former much more readily than the latter. The acids may be separated from their respective salts by dilute sulphuric acid, or by the action of lead-acetate and sulphydric acid.

On boiling with dilute acids (sulphuric, hydrochloric), or caustic potash, or baryta water, glycocholic acid is split up into cholalic (cholic) acid and glycin. Taurocholic acid may similarly be split up into cholalic acid and taurin. Thus

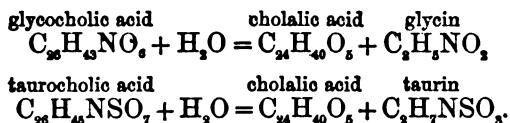

Both acids contain the same nitrogenless acid, cholalic acid; but this acid is in the first case associated or conjugated with the important nitrogenous body glycin, or amido-acetic acid, and in the second case with taurin, or amido-isethionic (amido-ethyl-sulphuric) acid. This decomposition takes place naturally in the intestine¹; so that from the two acids, after they have served their purpose in digestion, the two ammonia compounds are returned into the blood. Either of the two acids, or cholalic acid alone, when treated with sulphuric acid and cane-sugar, gives a magnificent purple colour (Pettenkofer's test) with a characteristic spectrum. A similar colour is produced by the action of the same bodies on albumin, amy alcohol, and some other organic bodies.

By dehydration, cholalic acid is converted into choloidic acid $\text{C}_{24}\text{H}_{38}\text{O}_5$, or into dialysin $\text{C}_{24}\text{H}_{26}\text{O}_5$.

Action of Bile on Food. In some animals at least bile contains a ferment capable of converting starch into sugar; but its action in

¹ Hoppe-Seyler, *Virchow's Archiv*, xxv. 181, xxvi. (1863) 519.

this respect is wholly subordinate. On proteids bile has no direct digestive action whatever. But when bile, or a solution of bile-salts, is added to a fluid containing the products of gastric digestion, a copious precipitate takes place, consisting, chiefly at least, of parapeptone, the greater part of the pepsin present being at the same time carried down mechanically, so that the supernatant liquid, even when reacidified, has little or no peptic powers.

It is not quite clear how far this is due simply to the fact of the bile being alkaline or to some special action of the bile-salts. It has been asserted also that not only parapeptone but peptone is carried down in the precipitate, and that the pepsin is really rendered inert by the bile.

With regard to the action of bile on fats, the following statements may be made:

Bile has a slight solvent action on fats, as seen in its use by painters. It has a slight but only slight emulsifying power. A mixture of oil and bile separate after shaking less rapidly than a mixture of oil and water; this action is probably due to the alkaline nature of bile. With free fatty acids, bile forms soaps, and these soaps are especially soluble in bile. Lastly, the wetting of membranes with bile, or with a solution of bile-salts, assists in the passage of fats through the membranes. Oil passes with considerable ease through a filter-paper kept wet with a solution of bile-salts as compared with one kept constantly wet with distilled water. Bile therefore must be said to have a slight action even on fats. It is probable however that it is more useful when combined with pancreatic juice than when acting by itself.

Pancreatic Juice.

Natural healthy pancreatic juice obtained by means of a temporary pancreatic fistula differs from the preceding fluids in the comparatively large quantity of proteids which it contains. Its composition varies according to the rate of secretion, for with the more rapid flow the increase of total solids does not keep pace with that of the water, though the ash remains remarkably constant.

By an incision through the linea alba the pancreatic duct can easily be found either in the rabbit or in the dog, and a cannula secured in it. There is no difficulty about a temporary fistula; but Bernard found that with permanent fistulæ the secretion altered in nature, and lost many of its characteristic properties. N. O. Bernstein¹, however, has succeeded in obtaining permanent fistulæ without any impairment of the secretion.

Healthy pancreatic juice is a clear viscid fluid, frothing when shaken. It has a very decided alkaline reaction, and contains few or no structural constituents.

¹ Ludwig's *Arbeiten*, 1869, p. 1.

The average amount of solids in the pancreatic juice of the dog when obtained from a temporary fistula is about 8 to 10 p. c.¹, but Bernstein² found in the thoroughly active secretion from a permanent fistula about 2.5 p. c. (1.68—5.39), .8 being inorganic matter. The important constituents are albumin, a peculiar form of casein, or alkali albumin (precipitable by saturation with magnesium sulphate), leucin and tyrosin, a small amount of fats and soaps, and a comparatively large quantity of sodium carbonate, to which the alkaline reaction of the juice is due, and which seems to be peculiarly associated with the albumin.

When cooled to 0° C. it is apt to undergo a sort of coagulation, becoming fluid again on being gently heated³.

According to Kühne⁴, fresh pancreatic juice of the dog always contains corpuscles similar to salivary corpuscles, and the coagulation observed by Bernard is a true coagulation, resulting in a product very similar to myosin. The coagulum however is speedily digested. *Perfectly* fresh juice, Kühne states, contains neither peptone nor tyrosin, and only the barest trace of leucin.

Action on Food-stuffs. On *starch*, raw or boiled, pancreatic juice acts with great energy, rapidly converting it into grape-sugar. All that has been said in this respect concerning saliva might be repeated in the case of pancreatic juice, except that the activity of the latter is far greater than that of the former; the pancreatic juice and the aqueous infusion of the gland are always capable of converting starch into grape-sugar, whether the animal from which they were taken be starving or well fed. From the juice, or, by the glycerine method, from the gland itself, an amylolytic ferment may be approximately isolated. On *proteids* it also exercises a solvent action, so far similar to that of gastric juice that by it the proteids are converted into peptone. If a few shreds of fibrin are thrown into a small quantity of pancreatic juice, they speedily disappear, especially at a temperature of 35° C., and the mixture is found to contain peptone. The activity of the juice in thus converting proteids into peptone, is favoured by increase of temperature up to 40° or thereabouts, and hindered by low temperatures; it is permanently destroyed by boiling. The digestive powers of the juice in fact depend, like those of gastric juice, on the presence of a ferment. A glycerine extract of pancreas, prepared in the same method as that of the gastric mucous membrane, is active on proteids (under appropriate conditions), like the native juice.

The appearance of fibrin undergoing pancreatic digestion is however different from that undergoing peptic digestion. In the former case the fibrin does not swell up, but remains as opaque as before, and appears to suffer corrosion rather than solution. But there is a still

¹ Bernard, *Lec. Phys. Exp.* (1855), II. 237.

² Bernstein, *op. cit.*

³ Bernard, *Lec. Phys. Exp.* II. 230.

⁴ *Verhandl. Heidelb. Naturhist. Med. Vereins*, 1876.

more important distinction between pancreatic and peptic digestion of proteids. Peptic digestion is essentially an acid digestion; we have seen that the action only takes place in the presence of an acid, and is arrested by neutralization. Pancreatic digestion, on the other hand, is essentially an alkaline digestion; the action will not take place unless some alkali be present; and the activity of an alkaline juice is arrested by acidification, and hindered by neutralization. The glycerine extract of pancreas is under all circumstances as inert in the presence of free acid as that of the stomach in the presence of alkalis. If the digestive mixture be supplied with sodium carbonate to the extent of 1 p. c., digestion proceeds rapidly, just as does a peptic mixture when acidulated with hydrochloric acid to the extent of .2 p. c. Sodium carbonate of 1 p. c. seems in fact to play in pancreatic digestion a part altogether comparable to that of hydrochloric acid .2 p. c. in gastric digestion.

When isolated ferment, as the glycerine extract of pancreas, is operated with, .1 p. c. of free hydrochloric acid is sufficient to arrest the action. With distilled water the digestion goes on but very slowly, and the addition of sodium carbonate quickens the change, in proportion to the quantity added, up to about .9 or 1.2 p. c. Beyond this, further alkali is a hindrance, and large quantities stop the process altogether. Bile, which arrests peptic digestion, seems, if anything, favourable to pancreatic digestion¹.

Corresponding to this difference in the helpmate of the ferment, there is in the two cases a difference in the nature of the products. In both cases peptone is produced, and such differences as can at present be detected between pancreatic and gastric peptones are comparatively slight; but in pancreatic digestion the bye product is not, as in gastric digestion, a kind of acid-albumin, but a body having more analogy with alkali-albumin.

Before solution has actually taken place the fibrin becomes altered in character. It is soluble not only in dilute acids and alkalis, but also in a 10 per cent. solution of sodium chloride, and the solutions obtained by the latter reagent are coagulable on boiling and on the addition of strong nitric acid. The first action of the pancreatic juice therefore seems to be to convert the proteid under digestion into a body intermediate between alkali-albumin and ordinary native albumin.

But though the general characters of pancreatic and gastric digestion are on the surface so similar, it is more than probable that profound differences do exist between them. This is shewn by the appearance, in the pancreatic digestion of proteids, of two remarkable nitrogenous crystalline bodies, *leucin* and *tyrosin*. When fibrin (or other proteid) is submitted to the action of pancreatic juice, the amount of peptone which can be recovered from the mixture falls far short of the original amount of proteids, much more so than in the

¹ Heidenhain, *Pflüger's Archiv*, x. (1875) 557.

case of gastric juice; and the longer the digestive action, the greater is this apparent loss. If a pancreatic digestion mixture be freed from the alkali-albumin by neutralization, and after concentration by evaporation be treated with excess of alcohol, most of the peptone will be precipitated. The alcoholic filtrate when concentrated, gives, on cooling, crystals of tyrosin, and the mother liquor from these crystals will afford abundance of crystals of leucin. Thus by the action of the pancreatic juice a considerable amount of the proteid, which is being digested, is so broken up as to give rise to products which are no longer proteid in nature. From its decomposition there arise leucin, tyrosin, and probably several other bodies, such as fatty acids and volatile substances. In gastric digestion such a complete destruction of proteid material occurs to a much less extent; neither leucin nor tyrosin can at present be considered as natural products of the action of pepsin.

As is well known, leucin and tyrosin are the bodies which make their appearance when proteids or gelatin are acted on by dilute acids, alkalis, or various oxidising agents. Now leucin is amidocaproic acid, and thus belongs distinctly to the fatty bodies, while tyrosin is a member of the aromatic group, being closely related to benzoic acid. So that in pancreatic digestion we have the large complex proteid molecule split up into its constituent fatty acid and aromatic molecules, and into its other less distinctly known components.

The presence of these bodies and of the alkali-albumin in pancreatic juice is probably due to an intrinsic digestion taking place in the secretion as it passes along the duct or after it has been collected. Among the supplementary products of pancreatic digestion may be enumerated a body which gives a violet colour with chlorine water (this reaction is often seen in the juice itself), and *indol*, to which apparently the strong and peculiarly faecal odour which makes its appearance during pancreatic digestion is due.

Indol, however, unlike the leucin and tyrosin, is possibly not a product of pure pancreatic digestion, but of an accompanying decomposition due to the action of organised ferments. A pancreatic digestive mixture soon becomes swarming with bacteria, in spite of careful precautions, when natural juice or an infusion of the gland is used. When isolated ferment is used, and atmospheric germs excluded, no odour whatever is produced¹, though carbonic acid and nitrogen are set free; and Kühne found no indol produced when pancreatic digestion was carried on in the presence of salicylic acid, which prevents the development of bacteria and like organisms.

After long-continued digestion, especially when accompanied by putrefactive decomposition, the amount of proteids which are carried beyond the peptone stage and broken up, may be very great. A slight difference between pancreatic and gastric digestion may be found in the fact, that while fibrin boiled as well as raw is readily acted on by pancreatic juice, boiled albumin, syntonin, &c. resist the action of pancreatic juice to a much greater extent than they do that of gastric juice.

¹ Hüfner, *J. f. Prakt. Chem.* N. F. x. 1.

Theory of digestive Proteolysis. The simplest view of peptic digestion is that of Brücke¹, that the fibrin or albumin, &c. is first converted into syntonin (parapeptone), and that the syntonin (parapeptone) is converted into peptone; and is moreover supported by the fact that the final result of digestion with a very active juice is nothing but peptone. There are facts however which shew that so simple a view cannot be accepted. Meissner² came to the conclusion, based on very laborious researches, that the conversion into syntonin was followed by the splitting up of that body into *peptone* and *parapeptone*, the latter being distinguished from ordinary syntonin not by its general characters, but by the fact that it was incapable of being further converted into peptone by the action of gastric juice, though it could undergo that change under the influence of pancreatic juice. He further described two subsidiary products, *metapeptone* and *dyspeptone*, but the characters he assigned to those bodies were unsatisfactory. He moreover spoke of three kinds of peptone, *A*, *B* and *C* peptone, the last not being precipitable, whilst the first two are, by acetic acid and potassium ferrocyanide, *A* in a weakly acid, *B* in a strongly acid solution; in other words, *C* is a perfect peptone and *A* and *B* are imperfect peptones. Kühne³ is of opinion that every natural proteid consists of, and may be split up into, two elements, belonging to what he calls respectively the *anti* group and the *hemi* group. When a proteid is digested by *trypsin*, such being the name which Kühne gives to the purified pancreatic ferment capable of acting on proteids, two peptones are produced, an *antipeptone* and a *hemipeptone*. Of these the first, antipeptone, undergoes no further change under the action of trypsin; it remains a peptone. Hemipeptone on the other hand is readily decomposed by trypsin into leucin, tyrosin and the other products of pancreatic digestion. So also when a proteid is digested by pepsin, the same antipeptone and hemipeptone are formed; but, unlike trypsin, pepsin cannot produce any further change in the hemipeptone. (The assertion that leucin and tyrosin appear as products of peptic digestion, is explained by the fact that pepsin is associated in the gastric membrane with a proteid body, which gives up considerable quantities of leucin and tyrosin when dissolved in a dilute acid. Trypsin also is associated with a similar body in the pancreas.) Thus the results of peptic and tryptic digestion together are antipeptone with leucin, tyrosin, &c., the latter arising from the profounder tryptic digestion of hemipeptone. Between these peptones however and the original proteid are various stages, and, under certain circumstances, various bye products. Thus antipeptone has for its antecedent *antialbumose* (Brücke's parapeptone) agreeing in its general characters with the syntonins, but capable of conversion into antipeptone only, never into hemipeptone. Similarly hemipeptone has an antecedent *hemialbumose* (apparently Meissner's *A* peptone) soluble in dilute acids and alkalis and in a 10 p. c. sodium-chloride solution, and convertible, by the agency of pepsin or trypsin, into hemipeptone, and of trypsin alone into leucin, tyrosin, &c. The action of dilute hydrochloric acid at 40° on proteids gives rise, on the side of the hemi-group, to hemialbumose and so to hemipeptone. By the action of sulphuric acid at 100° C. the hemipeptone is further reduced to leucin, tyrosin, &c. On the side of the anti-group these agents give rise to a body which Kühne calls *antialbumate*. This

¹ *Wien. Sitzungsbericht*, xxxvii. 131, xliii. 601.

² *Zt. f. Rat. Med.* vii. 1, viii. 280, x. 1, xii. 46, xiv. 303.

³ *Verhandl. Naturhist. Med. Vereins, Heidel.* 1876.

substance also occurs in digestive mixtures where the pepsin is insufficient. It is not capable of any change under the influence of pepsin, but by trypsin is converted into anti-peptone. It is evidently the real para-peptone of Meissner. These results of Kühne it will be seen reconcile some previous contradictions; and the distinction of the anti- and hemi-groups, if it prove as general as Kühne supposes, throws a great light on proteid metabolism. It may be remarked, in passing, that hemialbumose agrees very closely with the peculiar proteid body discovered by Bence Jones in the urine of a case of osteomalacia. According to Kühne, while the activity of trypsin is entirely destroyed by digestion with pepsin, trypsin has no such effect on pepsin.

On the gelatiniferous elements of the tissues, unless they have been previously treated with acid or heated with water, pancreatic juice appears to have no solvent action. In this respect it affords a striking contrast to gastric juice¹.

Trypsin, unlike pepsin, will dissolve mucin. Like pepsin, it is inert towards nuclein, horny tissues, and the so-called amyloid matter.

On *Fats* pancreatic juice has a twofold action: it emulsifies them, and it splits up neutral fats into their respective acids and glycerine.

If hog's lard be gently heated till it melts and be then mixed with pancreatic juice before it solidifies on cooling, a creamy emulsion, lasting for almost an indefinite time, is formed. So also when olive oil is shaken up with pancreatic juice, the separation of the two fluids takes place very slowly, and a drop of the mixture under the microscope shews that the division of the fat is very minute. An alkaline aqueous infusion of the gland has similar emulsifying powers.

If perfectly neutral fat be treated with pancreatic juice, especially at the body-temperature, the emulsion speedily takes on an acid reaction, and by appropriate means not only the corresponding fatty acids but glycerine may be obtained from the mixture. When an alkali is present, the fatty acids thus set free form their corresponding soaps.

Pancreatic juice contains fats, and is consequently apt after collection to have its alkalinity reduced, and an aqueous infusion of a pancreatic gland (which always contains a considerable amount of fat) very speedily becomes acid.

Thus pancreatic juice is remarkable for the power it possesses of acting on all the food-stuffs, on starch, fats and proteids.

The action on starch and on proteids is certainly, and the splitting up of fatty acids is probably, due to the presence of distinct ferments, and Danilewsky² has suggested a method for isolating these three ferments.

¹ Ewald and Kühne, *Verhandl. Naturhist. Med. Vereins, Heidelberg*. Bd. I. (1876).

² Virchow's *Archiv*, xxv. p. 279.

The emulsifying power, on the other hand, is connected with the general composition of the juice (or of the aqueous infusion of the gland), being probably in large measure dependent on the alkali-albumin present. The proteolytic ferment trypsin contains, according to Kühne, a considerable quantity of nitrogen; and the fact that it can be digested by pepsin would seem to indicate that it is really proteid in nature. There are no means of distinguishing the amyolytic ferment of the pancreas from ptyalin.

The action of pancreatic juice, or of the infusion or extract of the gland, on starch, is seen under all circumstances, whether the animal be fasting or not. The same may probably be said of the action on fats.

Pancreatic juice, when secreted in a normal state, is always active on proteids¹. The glycerine extract or aqueous infusion of the gland, on the contrary, differs at different times; prepared from an animal some 4 to 10 hours after food has been taken, it is very powerful; prepared from a fasting animal, it exhibits scarcely any action at all. To this point we shall return immediately.

Succus Entericus.

When, in a living animal, a portion of the small intestine is ligatured, so that the secretions coming down from above cannot enter its canal, while yet the blood-supply is maintained as usual, a small amount of secretion collects in its interior. This is spoken of as the *succus entericus*, and is supposed to be furnished by the glands of Lieberkühn. We have no exact knowledge however as to what extent such a secretion takes place under normal circumstances; and the statements with regard to its action are conflicting. Thus it has been said to act on starch, to convert proteids into peptone, and to emulsify fats; on the other hand, each of these actions has been denied.

Thiry² divided the small intestine in two places at some distance apart. By fine sutures he united the lower end of the upper with the upper end of the lower section, thus as it were cutting out a whole piece of the small intestine from the alimentary tract. In successful cases, union between the cut surfaces took place, and a shortened but otherwise satisfactory canal was established. Of the isolated piece the lower end was carefully closed by sutures, while the upper was brought to the wound in the abdominal wall and secured there. A fistula was thus formed, leading into a short piece of intestine quite isolated from the rest of the alimentary canal. From this isolated intestine Thiry obtained a thin yellowish alkaline albuminous secretion which dissolved fibrin very much in the same way as does pancreatic juice, but was ineffectual on other proteids and had no action on starch. Kölliker and H. Müller found that proteids introduced into the intestines were digested in the case of carnivora, but not in the case of herbivora. Funke³ also agrees with Thiry that starch

¹ N. O. Bernstein, *l. c.*

² *Wien. Sitzungsbericht*, L. 77.

³ *Lehrb.* p. 190.

injected into isolated loops of rabbit's intestine is not converted into sugar; while Frerichs and Busch came to the opposite conclusion. Certainly pieces of the intestine of the pig or of the rabbit, or a glycerine extract of the pieces, will rapidly convert starch into sugar; and it is difficult to suppose that this action is due to an admixture of pancreatic juice which had not been thoroughly removed by washing, since pieces of the intestine of the sheep, which are also subject to admixture with active pancreatic juice, are, when similarly treated, inert as far as starch is concerned. Still no great stress can be laid on this, since an amylolytic ferment can be obtained from almost every part of the body of a pig or a rabbit.

Succus entericus has also been said to change cane- into grape-sugar, and by a fermentative action to convert cane-sugar into lactic acid, and this again into butyric acid with the evolution of carbonic acid and free hydrogen.

Of the possible action of other secretions of the alimentary canal, as of the cæcum and large intestine, we shall speak when we come to consider the changes in the alimentary canal.

Of the secretion of Brunner's glands we can only say that it is a viscid fluid containing mucus, which does not act on fats, and probably not on proteids. ✓

SEC. 2. THE ACT OF SECRETION IN THE CASE OF THE DIGESTIVE JUICES, AND THE NERVOUS MECHANISMS WHICH REGULATE IT.

The various juices whose properties we have just studied, though so different from each other, are all drawn ultimately from one common source, the blood, and they are poured into the alimentary canal, not in a continuous flow, but intermittently as occasion may demand. The epithelium cells which supply them have their periods of rest and of activity, and the amount and quality of the fluids which these cells secrete are determined by the needs of the economy as the food passes along the canal. We have therefore to consider how the epithelium cell manufactures its special secretion out of the materials supplied to it by the blood, and how the cell is called into activity by the presence of food at some distance from itself, or by circumstances which do not bear directly on itself. In dealing with these matters in connection with the digestive juices, we shall have to enter at some length into the physiology of secretion in general.

The question which presents itself first is, Does the epithelium cell simply serve as a filter, merely draining off from the blood the already formed constituents of its secretion, each cell being fitted in some way to catch and deliver particular substances? in other words, Is secretion merely selection, just as from a mixture of shots of various sizes a selection might be made by passing them over a series of sieves with meshes of varying width? or does the cell draw

upon the blood for the nutritive elements required for the growth of all protoplasm, and out of those common elements manufacture in the recesses of its own substance the chemical bodies which characterize the fluid it pours forth?

This question is naturally the first to be asked, nevertheless it will be of advantage to defer it for the present, and, while still bearing it in mind, to pass on to the second question: By what mechanism is the activity of the secreting cells brought into play?

While fasting, a small quantity only of saliva is poured into the mouth; the buccal cavity is just moist and nothing more. When food is taken, or when any sapid or stimulating substance, or indeed a body of any kind, is introduced into the mouth, the flow induced may be very copious. Indeed the quantity secreted in ordinary life during 24 hours has been roughly calculated at as much as from 1 to 2 litres. An abundant secretion in the absence of food in the mouth may be called forth by an emotion, as when the mouth waters at the sight of food, or by a smell, or by events occurring in the stomach, as in some cases of nausea. Evidently in these cases some nervous mechanism is at work. In studying the action of this nervous mechanism, it will be of advantage to confine our attention at first to the **submaxillary gland**.

The submaxillary gland (Fig. 36) is supplied with nerves from two sources: from the cervical sympathetic along the submaxillary arteries, and from the seventh or facial nerve by fibres, which, running in the chorda tympani, join the lingual branch of the fifth nerve, from which they diverge close under the lower jaw, and run as a small nerve close beside the duct to the gland.

If a tube be placed in the duct, it is seen that when sapid substances are placed on the tongue, or the tongue is stimulated in any other way, or the lingual nerve is laid bare and stimulated with an interrupted current, a copious flow of saliva takes place. If the sympathetic be divided, stimulation of the tongue or lingual nerve still produces a flow. But if the small chorda nerve spoken of above be divided, stimulation of the tongue or lingual nerve produces no flow.

Evidently the flow of saliva is a nervous reflex action, the lingual nerve serving as the channel for the afferent and the small chorda nerve for the efferent impulses. If the trunk of the lingual be divided above the point where the chorda leaves it, as at Fig. 36 *n. l.*, stimulation of the tongue produces, under ordinary circumstances, no flow. This shews that the centre of the reflex action is higher up than the point of section; it lies in fact in the brain.

In the angle between the lingual and the chorda, where the latter leaves the former to pass to the gland, lies the small submaxillary ganglion (represented diagrammatically in Fig. 36, *sm. gl.*), from which branches pass to the lingual on the one hand and to the chorda on the other; branches may also be traced towards the ducts and glands and towards the tongue. It has been much debated whether this ganglion can act as a centre of reflex action.

Bernard¹ found that after he had divided the conjoined lingual and chorda at about one cm. above the place where the chorda diverges to the gland (as at *n. l'* Fig. 36), stimulation of the lingual at about 3 or 4 cm. distance below the ganglion still caused a flow of saliva; this effect however was no longer seen when the branches passing from the ganglion to the lingual had been previously divided. He explained the result by supposing that the impulses generated by the stimulus were conveyed by afferent fibres in the lingual, along the lingual roots of the ganglion to the ganglion, and were thence reflected by efferent fibres along the branches from

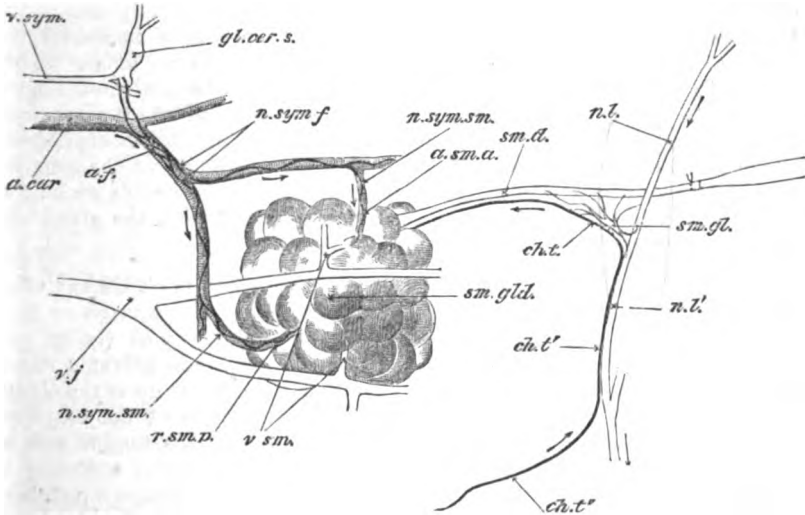

FIG. 36.

DIAGRAMMATIC REPRESENTATION OF THE SUBMAXILLARY GLAND OF THE DOG WITH ITS NERVES AND BLOOD-VESSELS.

(This is not intended to illustrate the exact anatomical relations of the several structures.)

sm. gland. The submaxillary gland, into the duct (*sm. d.*) of which a cannula has been tied. The sublingual gland and duct are not shewn.

n. l., n. l'. The lingual branch nerve. *ch. t., ch. t'.* The chorda tympani, proceeding from the facial nerve, becoming conjoined with the lingual at *n. l'* and afterwards diverging and passing to the gland along the duct.

sm. gl. The submaxillary ganglion with its several roots. *n. l.* The lingual proceeding to the tongue.

a. car. The carotid artery, two branches of which, *a. sm. a.* and *r. sm. p.*, pass to the anterior and posterior parts of the gland. *v. sm.* the anterior and *v.* the posterior veins from the gland, falling into *v. j.* the jugular vein.

v. sym. The conjoined vagus and sympathetic trunks.

gl. cer. s. The super-cervical ganglion, two branches of which forming a plexus (*a. f.*) over the facial artery, are distributed (*n. sym. sm.*) along the two glandular arteries to the anterior and posterior portions of the gland.

The arrows indicate the direction taken by the nervous impulses during reflex stimulation of the gland. They ascend to the brain by the lingual and descend by the chorda tympani.

¹ *Comptes Rendus*, 1862, II. 341.

the ganglion to the chorda and so to the gland. The ganglion, in fact, acted as a reflex centre. The same apparent reflex secretion could also be induced but less readily by pinching the peripheral branches of the lingual near the tongue, or by dipping them into concentrated salt solution. In this case also the secretion failed to appear if the lingual roots of the ganglion were divided. Such a reflex secretion was very difficult to obtain by stimulation of the mucous membrane of the tongue; but Bernard was successful when he stimulated the tongue directly with a galvanic current or drew the tongue out and placed ether on its surface. The secretion in all these cases was accompanied by a dilation of the blood-vessels of the gland, and the effect on the gland was indeed wholly similar to that of directly stimulating the chorda. Bernard further insisted that in these experiments no anæsthetics were to be used, and observed that the reflex effect was no longer visible when two or three days had elapsed after section of the conjoined lingual and chorda trunks. Both these facts rather militate against his view, since it seems improbable that a sporadic ganglion should be susceptible of anæsthetics, or that degeneration and functional incapacity of the ganglion should follow upon section of the conjoined lingual and chorda so long as the afferent and efferent connections of the ganglion with the gland and tongue were kept up.

Eckhard¹ in repeating Bernard's experiments failed to obtain any effect from dipping the endings of the lingual nerve in salt solution or from placing ether on the tongue, and he very naturally argued (being supported in this by Heidenhain²) that the effects seen when galvanic stimulation was employed were due to an escape of the current upon the chorda fibres. Schiff³ did obtain reflex secretion after section of the conjoined lingual and chorda, by direct galvanic stimulation of the tongue and by pouring ether on the surface of that organ; but the currents necessary in the first case to produce any effect were so strong that escape must have taken place, and in the second case the secretion appeared even though the lingual was divided close under the tongue, and when therefore this nerve could not have been the channel for conveying impulses to the sub-maxillary ganglion. He further pointed out that in large dogs at all events, certain fibres of the chorda after running along the conjoined lingual and chorda do not leave the lingual with the rest of the fibres going straight to the gland, but continue in the lingual close up to the tongue, then bend round and as recurrent fibres run back and eventually join the nerve going to the gland. He in consequence argued that Bernard in stimulating the lingual below the divergence of the chorda was in reality stimulating not afferent but efferent fibres. But in such a case, these recurrent fibres must pass to the chorda through the ganglion, if Bernard's result be true that the reflex effect ceases when the lingual roots of the ganglion are divided. Schiff further states, that these recurrent fibres degenerate in the retrograde portion of their course when the lingual is divided near the tongue, and that no effect follows upon stimulation of the lingual after section of the conjoined chorda and lingual if the lingual have some five or six days previously been divided close to the tongue so as to cause degeneration of the recurrent fibres, provided that the stimulation be

¹ *Zt. f. Rat. Med.* xxix. (1867), p. 74.

² *Breslau Studien*, 1868.

³ Moleschott's *Untersuchungen*, x. (1870) 423.

not so strong as to lead to an escape of the current to the main chorda fibres. In small dogs Schiff could not so readily demonstrate these recurrent fibres, and though he says the apparent reflex secretion is more easily obtained in large dogs, such as Bernard probably used, than in smaller ones, it is improbable that mere size should make such a difference in nervous distribution; and if an escape of current can explain the results in the one case it can also probably in the other.

Bidder's account of the nerves of the ganglion at first sight offers support to Bernard's views. In the dog he finds, passing from the ganglion direct to the tongue, nerves containing medullated fibres which do not degenerate when the chorda is divided. These fibres accordingly would seem to take their origin in the ganglion and to be the afferent nerves required for Bernard's views. When Bidder divided the conjoined lingual and chorda, he found the chorda fibres after about three weeks completely degenerated, not only those forming the nerve going to the gland but also those constituting the branches going to the ganglion:—i.e. the chorda roots of the ganglion. In the ganglion and in the branches going from the ganglion to the gland were seen numerous degenerated fibres in the midst of undegenerated (but non-medullated) fibres which seemed to have their origin in the ganglion itself. Thus after complete degeneration of the true chorda fibres, there still remained intact, (1) the ganglion, (2) fibres from the ganglion to the tongue, and (3) fibres from the ganglion to the gland, in fact, exactly the nervous mechanism demanded by Bernard's view. But Bidder, like Eckhard, failed to obtain a reflex secretion by pouring ether on the tongue after division of the conjoined lingual and chorda, and he found that galvanic stimulation of the nerves going from the ganglion to the tongue was of no effect, provided that errors due to escape of current on to the main chorda fibres were avoided by previously inducing through section degeneration of the chorda fibres including the chorda roots of the ganglion. Since this degeneration of the chorda fibres was unaccompanied by any degeneration of the ganglion itself or of the fibres passing from the tongue to the ganglion, and most of the fibres passing from the ganglion to the gland still remained intact, Bernard's explanation of his inability to get reflex secretion for more than a few days after section of the united lingual and chorda, is rendered insufficient; indeed the absence of all effect after degeneration of the chorda fibres has once been established shews that the ganglion is not the essential factor in his experiments, that in some way or other the chorda fibres must have themselves been directly stimulated.

We have contrary to our wont given this controversy in detail on account of the great importance of the subject. The submaxillary ganglion is the only case in which it has been with any success attempted to demonstrate by experiment the reflex action of a sporadic ganglion, and the question whether sporadic ganglia can or cannot serve as centres of reflex action is at the present time at least a question of pressing interest.

Stimulation of the glossopharyngeal is even more effectual than that of the lingual. Probably this indeed is the chief afferent nerve in ordinary secretion. Stimulation of the mucous membrane of the stomach (as by food introduced through a gastric fistula) or of the vagus also produces a flow, as indeed may stimulation of the sciatic,

¹ Reichert u. Du Bois-Reymond's *Archiv*, 1867, p. 1.

and probably of many other afferent nerves. All these cases are instances of reflex action, the cerebro-spinal system acting as a centre. In most cases the centre lies in the medulla oblongata, and secretion may be caused by direct stimulation of this organ; where ideas or emotions cause a flow, the stimulation begins higher up in the brain; and in cases where the sense of taste, as distinguished from general sensation, is concerned in the matter, it is probable that the afferent impulses ascend into the brain higher up than the medulla, before they return as efferent impulses. In all these cases the chorda tympani is the sole efferent nerve. Section of that nerve, either where the fibres pass from the lingual nerve and the submaxillary ganglion to the gland, or where it runs in the same sheath as the lingual, or in any part of its course from the main facial trunk to the lingual, puts an end at once (with the disputed exception mentioned above) to the possibility of any flow being excited by stimuli applied to the mouth, or any part of the body other than the gland itself.

This statement is probably too absolute; for though satisfactory evidence of reflex excitation of the submaxillary gland by means of the sympathetic is not forthcoming, it seems unlikely that the secretory as distinguished from the vaso-motor activity of this nerve should never be put to use in actual life.

In life, then, the flow of saliva is brought about by the advent to the gland along the chorda tympani of efferent impulses, started chiefly by reflex actions. The inquiry thus narrows itself to the question: In what manner do these efferent impulses cause the increase of flow?

If in a dog a tube be introduced into Wharton's duct, and the chorda be divided, the flow, if any be going on, is from the lack of efferent impulses arrested. On passing an interrupted current through the peripheral portion of the chorda, a copious secretion at once takes place, and the saliva begins to rise rapidly in the tube; a very short time after the application of the current the flow reaches a maximum which is maintained for some time, and then, if the current be long continued, gradually lessens. If the current be applied for a short time only, the secretion may last for some time after the current has been shut off. The saliva thus obtained is but slightly viscid, and contains but few salivary corpuscles or protoplasmic lumps. If the gland itself be watched, while its activity is thus roused, it will be seen that its arteries are dilated, and its capillaries filled, and that the blood flows rapidly through the veins in a full stream and of bright arterial hue, frequently with pulsating movements. If a vein be opened, this large increase of flow, and the lessening of the ordinary deoxygenation of the blood consequent upon the rapid stream, will be still more evident. It is clear that excitation of the chorda acts on some local vaso-motor centre in the gland, and largely dilates the arteries; it acts energetically as a dilator nerve.

Thus stimulation of the chorda brings about two events: a dilation of the blood-vessels of the gland, and a flow of saliva. The question at once arises, Is not the latter simply the result of the former? The activity of the epithelial secreting cell, like that of any other form of protoplasm, is dependent on blood-supply. When the small arteries of the gland dilate, the capillaries become fuller, more blood passes through them in a given time, a larger amount of nutritive material passes away from them into the surrounding lymph-spaces, and so into the epithelium cells (and it must be remembered that though by the dilation the pressure in the arteries of the gland is diminished, that of the capillaries and veins is increased), the result of which must be to quicken the processes going on in the cells, and to stir these up to greater activity. This must be so; but it does not necessarily follow that the activity thus excited should take on the form of secretion. It is quite possible to conceive that the increased blood-supply should lead only to the accumulation in the cell of the constituents of the saliva, or of the materials for their construction, and not to a discharge of the secretion. A man works better for being fed, but feeding does not make him work in the absence of any stimulus. The increased blood-supply therefore, while favourable to active secretion, need not necessarily bring it about. Moreover, the following facts deserve attention. When the chorda is energetically stimulated, the pressure acquired by the saliva in the duct exceeds the arterial blood-pressure for the time being; that is to say, the pressure of fluid in the gland outside the blood-vessels is greater than that of the blood inside the blood-vessels. This must, whatever be the exact mode of transit of nutritive material through the vascular walls, tend to check that transit. Again, if the head of an animal be rapidly cut off, and the chorda immediately stimulated, a flow of saliva takes place far too copious to be accounted for by the emptying of the salivary channels through the contraction of their walls. In this case secretion is excited in the absence of blood-supply. Lastly, if a small quantity of atropin be injected into the veins, stimulation of the chorda produces no secretion of saliva at all, though the dilation of the blood-vessels takes place as usual. This remarkable fact can only be accounted for by supposing that the chorda contains two sets of fibres, one secreting fibres, acting directly on the epithelium cells only, and the other vaso-motor or dilating fibres, acting on the blood-vessels only, and that atropin, while it has no effect on the latter, paralyzes the former just as it paralyzes the inhibitory fibres of the vagus. These facts, and especially the last, clearly prove that when the chorda is stimulated, there pass down the nerve, in addition to impulses affecting the blood-supply, impulses affecting directly the protoplasm of the secreting cells, and calling it into action, just as similar impulses call into action the contractility of the protoplasm of a muscular fibre. Indeed the two things, secreting activity and con-

tracting activity, are quite parallel. We know that when a muscle contracts, its blood-vessels dilate; and just as by atropin the secreting action of the gland may be isolated from the vascular dilation, so by urari muscular contraction may be removed, and leave dilation of the blood-vessels as the only effect of stimulating the muscular nerve. In both cases the greater flow of blood is an adjuvant to, not the exciting cause of, the activity of the protoplasm.

If the chorda acts thus directly on the secreting cell, there must be a physiological and probably an anatomical connection between the cell and the nerve-fibre. Although Pflüger's observations as to the actual mode in which the nerves end in the gland have not been generally accepted, nerve-fibres have been traced to the exterior of the alveoli, and Kupffer¹ has shewn that in the salivary glands of *Blatta*, the nerve-fibres certainly pass into the protoplasm and apparently end in the nuclei of the cells.

When the cervical sympathetic is stimulated, the vascular effects are the exact contrary of those seen when the chorda is stimulated. The small arteries are contracted, and a small quantity of dark venous blood escapes by the vein. Sometimes, indeed, the flow through the gland is almost arrested. The sympathetic therefore acts as a constrictor nerve, and in this sense is antagonistic to the chorda. We have already referred to the probable existence of a local vaso-motor centre situated in the gland itself, in which indeed there are found ganglionic cells in abundance. The fact that section of the cervical sympathetic does not cause complete dilation of the vessels of the gland—the dilating effects of stimulation of the chorda being fully evident after previous section of the sympathetic—affords additional support to this view. We may accordingly state that, while the chorda tympani inhibits, the sympathetic exalts, the action of this local centre.

The antagonism between the two, as far as the blood supply is concerned, is very imperfect, the sympathetic being the more powerful; thus stimulation of the chorda produces very little effect in altering the results of a concomitant *strong* stimulation of the sympathetic².

The effects on the flow of saliva from the submaxillary gland of the dog brought about by stimulation of the sympathetic, are very peculiar. A slight increase of flow is seen, but this soon passes off, and what saliva is secreted is remarkably viscid, of higher specific gravity, and richer in corpuscles and protoplasmic lumps, and it is said to be more active on starch than the chorda saliva⁴. This action of the sympathetic is not affected by atropin.

Czermak⁵ was the first to point out that the effect of chorda stimulation was hindered by a concomitant stimulation of the sympathetic; and

¹ Stricker's *Histology*, Syd. Soc. Trans. Art. Salivary Glands (by Pflüger).

² Ludwig's *Festgabe*, p. lxiv.

³ Frey, Ludwig's *Arbeiten*, 1876, p. 89.

⁴ Eckhard, *Beiträge*, II. (1860), p. 81. III. (1864), p. 39.

⁵ *Wien. Sitzungsberichte*, xxv. (1857), p. 3.

Kühne¹ observed that no flow at all took place, when both nerves were simultaneously stimulated with minimum currents, *i.e.* with currents which applied to either nerve separately were just sufficient to produce an obvious flow; each nerve in fact seemed to be the antagonist of the other. Most observers agree that when both chorda and sympathetic are stimulated at the same time with strong currents, the action of the chorda, contrary to what takes place as far as the blood-supply is concerned, prevails as far as secretion is concerned, *i.e.* the flow is copious and watery. Heidenhain² found that when the stimulation of the sympathetic was continued (*i.e.* repeated stimulations with brief intervals) for some time the secretion, at first viscid, eventually became watery like chorda saliva, and that the effect of a prolonged stimulation of the chorda was to lessen or annul the effect of any sympathetic stimulation immediately following. He also remarked, as Ludwig and Becker³ had already observed in the case of chorda stimulation, that after prolonged (intermittent) stimulation of either nerve the percentage of solids in the saliva diminished, the deficit falling much more on the organic than on the inorganic constituents. These various facts not only afford additional evidence that the secretory activity of the salivary nerves is something distinct from their vaso-motor activity, but also go far to prove that the sympathetic as well as the chorda acts directly on the nerve-cells, and that its effects cannot be explained by reference to any indirect action. But they do not leave the matter in a satisfactory condition. Heidenhain distinguishes two processes in the act of secretion of saliva: a formation or rather a discharge of mucus (*i.e.* the conversion of the mucus of the mucous cells into a more soluble form) and a secretion of fluid; and he believes that these two processes are governed by separate fibres, both kinds of fibres being present in both chorda and sympathetic, but the "mucus-forming" fibres predominant in the sympathetic and the "fluid-secreting" fibres in the chorda. To reconcile his view with facts he is further obliged to suppose, in analogy with the corresponding views concerning vaso-dilator and vaso-constrictor fibres, that the mucus-forming fibres are more readily exhausted than the other kind. It is worthy of notice that though in the dog sympathetic saliva is undoubtedly more viscid than chorda saliva, in the cat the very opposite holds good⁴; and that in the cat atropin, unlike the case of the dog, prevents the sympathetic secretion. In the rabbit, the chorda saliva of which, unlike that of the dog, is entirely free from mucus, the sympathetic saliva, though scanty, is also free from mucus.

Bernard⁵ observed that after section of all the nerves going to the gland, a continuous and fairly copious secretion of a watery saliva soon set in and continued for some time. Heidenhain⁶ observed the same thing, the continuous flow beginning from four to twenty-four hours after section of the nerves, soon reaching a maximum and after some weeks decreasing again as regeneration of the nerves took place. During this 'paralytic secretion,' as it is called, the gland diminishes in size, and in some cases where the nerves are not restored appears to undergo degeneration. A

¹ *Lehrb.* p. 5 (1866).

² *Breslau. Studien*, iv. (1868).

³ *Zt. f. Rat. Med.* i. 278.

⁴ Langley, J. N., from an unpublished research.

⁵ Robin's *Journal de l'Anat. et de la Physiolog.* I. (1864), p. 511.

⁶ *Op. cit.*

paralytic secretion also appears if the chorda only be divided; and urari-poisoning¹ produces a similar flow. The paralytic secretion is watery but contains both mucin and salivary corpuscles. The mechanism of its production is obscure, but Heidenhain observed a similar continuous secretion to result when the duct of the gland was kept ligatured for twenty-four hours and then opened. Heidenhain also observed that when the nerves of the gland on one side were cut, a paralytic secretion appeared in the gland of the other side also.

The natural reflex act of secretion may be inhibited, like the reflex action of the vaso-motor nerves, at its cerebral centre. Thus when, as in the old rice ordeal, fear parches the mouth, it is probable that the afferent impulses passing from the mouth cease, through emotional inhibition of their reflex centre, to give rise to efferent impulses.

The history of the submaxillary gland then teaches us that secretion in this instance is a reflex action, the efferent impulses of which directly affect the secreting cells, and that the vascular phenomena may assist, but are not the direct cause of the flow. We have dwelt long on this gland because it has been more fruitfully studied than any other. The nervous mechanisms of the other secretions may be passed over much more rapidly.

In the **parotid** gland a flow is caused by stimulation of the auriculo-temporal branch of the fifth nerve.

The active fibres in this nerve probably spring from the facial, passing through the lesser superficial petrosal nerve and the otic ganglion. Stimulation of the sympathetic also causes a slight flow, but the saliva in this case is not viscid. Eckhard² failed, in the parotid of the sheep, to get any effect, whatever nerve he stimulated.

The presence of food in the **stomach** causes a copious flow of gastric juice. The quantity secreted in man in the twenty-four hours has been calculated at from 13 to 14 litres. When the gastric mucous membrane is stimulated mechanically, as with a feather, secretion is excited: but to a very small amount. A dilute alkali seems to be the most energetic local stimulus; thus the swallowing of saliva at once provokes a flow of gastric juice. During fasting the gastric membrane is of a pale grey colour; during digestion it becomes red and flushed, and to a certain extent tumid. The secretion of gastric juice therefore seems to be accompanied by vascular dilation in the same way as is the secretion of saliva.

Seeing that, unlike the case of the saliva, food is brought into the immediate neighbourhood of the secreting cells, it is exceedingly probable that a great deal of the secretion is the result of the working of a local mechanism. Nevertheless, since the flow of gastric juice may be excited or arrested by events in distant parts, as by emotions, the gastric membrane must be in some way or other brought into relation with the central nervous system; and probably future inquiries will disclose a mechanism as complete as that of the sub-

¹ Bernard, *Op. cit.*

² *Beiträge*, vii. 161.

maxillary gland. At present, however, the matter is very imperfectly known.

Rutherford¹ found that the gastric membrane, flushed during digestion, became pale when the vagi were cut. Stimulation of the central end of either vagus caused a reddening of the gastric membrane, but stimulation of the peripheral end produced no constant effect. From these results we may infer that afferent impulses pass up the vagus and by inhibiting in the medulla the vaso-motor centre governing the gastric blood-vessels, cause a dilation of the latter. The efferent impulses evidently do not descend by the vagus; probably therefore their path is along the sympathetic. After division of both vagi, gastric juice of normal acidity and peptic power continues to be secreted. The same occurs after division of both splanchnic nerves, and even after extirpation of the cœliac ganglion.

When the acid contents of the stomach are poured over the orifice of the biliary duct, a gush of **bile** takes place. Indeed, stimulation of this region of the duodenum with a dilute acid at once calls forth a flow, whereas alkaline fluids so applied have little or no effect. This, probably, is a reflex action leading to the contraction of the muscular walls of the gall-bladder and ducts, accompanied by a relaxation of the sphincter of the orifice; it refers therefore to the discharge rather than to the secretion of bile.

When the secretion of the bile is studied by means of a biliary fistula (which, however, probably induces errors by the total withdrawal from the body of the bile which should naturally flow into the intestine), it is seen to rise rapidly after meals, reaching its maximum in from four to ten hours. There seems to be an immediate, sudden rise when food is taken, then a fall, followed subsequently by a more gradual rise up to the maximum, and ending in a final fall. It is exceedingly probable that these variations are due to the action of the nervous system, but the exact nature of the nervous mechanism is unknown.

Stimulation of the splanchnics causes an increase in the flow from a biliary fistula, but this is probably due to contraction of the bile-ducts.

Rutherford² finds that the injection of various substances, ipecacuanha, podophyllin, &c., into the duodenum causes an increase in the actual secretion, but the manner of the increase is not yet explained.

Unlike the case of saliva, the pressure under which the bile is secreted never exceeds that of the blood, and is in general very low. When a water manometer is connected with the gall-bladder of a guinea-pig, the ductus choledochus being ligatured, the fluid may rise in the manometer to about 200 mm. (equivalent to about 16 mm. mercury), but not much beyond. If water be poured into the open end of the manometer so as to raise the pressure much above 200 mm., resorption into the circulation takes place, and the fluid in the manometer sinks to, or even below, the normal level³. The

¹ *Phil. Trans. Edin.* xxvi. (1870).

² *Journ. Anat. Phys.* x. xi. (1876, 77).

³ Friedländer u. Barisch (Heidenhain) *Du Bois-Reymond's Archiv*, 1860, p. 646.

quantity secreted in man in the 24 hours has been estimated roughly at about 10 kilos, but the calculations are based on very imperfect data.

The relation of the nervous system to the secretion of the **pancreatic juice** has been studied rather more fully. N. O. Bernstein¹ finds that in the dog the secretion, after food has been taken, follows the curve given in Fig. 37. There is a sudden maximum rise im-

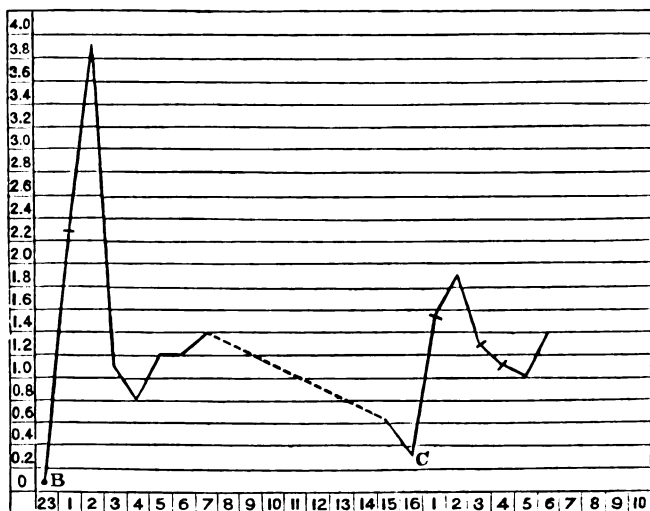

FIG. 37. DIAGRAM ILLUSTRATING THE INFLUENCE OF FOOD ON THE SECRETION OF PANCREATIC JUICE. (N. O. Bernstein.)

The abscissæ represent hours after taking food; the ordinates represent in c. c. the amount of secretion in 10 min. A marked rise is seen at B immediately after food was taken, with a secondary rise between the 4th and 5th hours afterwards. Where the line is dotted the observation was interrupted. On food being again given at C, another rise is seen, followed in turn by a depression and a secondary rise at the 4th hour. A very similar curve would represent the secretion of bile.

mediately after food has been taken. This must be due to nervous action. Then follows a fall, after which there is, as in bile, a secondary rise, the causation of which may, or may not, be nervous in nature. The quantity secreted in 24 hours by man has been calculated at 300 c. c. Like the salivary glands, the pancreas while secreting is flushed, through dilation of its blood-vessels.

According to N. O. Bernstein, the secretion is at once stopped by nausea or vomiting. Section of the vagus stops the secretion for a short time; it soon however recommences. Stimulation of the central vagus causes an arrest lasting for some time after the stimulus has been removed. It is probable therefore that the arrest of secretion during vomiting is due to

¹ Ludwig's *Arbeiten*, 1869.

afferent impulses ascending the vagus and descending by some other channel. If all the nerves going to the pancreas around the pancreatic artery be severed as completely as possible, a continuous paralytic flow, not increased but rather diminished by food, and very slightly if at all hindered by nausea or stimulation of vagus, is brought on. Heidenhain¹ states that stimulation of the medulla oblongata causes an increased flow.

With regard to the *succus entericus* our information is very limited. Thiry² found that in the isolated intestine the secretion was not a constant one, but needed for its production some stimulus (mechanical or other) which probably acted in a reflex manner.

Moreau³ found that after section of the nerves going to a piece of intestine isolated after Thiry's method, a copious flow of a dilute intestinal juice takes place. This is altogether comparable to the paralytic flow of saliva and pancreatic juice.

Thus, while the influence of the nervous system is in the case of the submaxillary gland tolerably clear, in the case of the other secretions we have much yet to learn, and must rest rather on the analogy with the submaxillary gland, than on any known facts. We cannot, however, go far wrong, if we conclude that in all cases secretion is essentially due to an increase in the activity of the epithelium cells, and that variations in the blood-supply have a secondary effect only.

It must however be borne in mind that substances brought to the secreting cell by the blood may possibly act as chemical stimuli of its protoplasm, just as certain chemical substances may stimulate a muscular fibre to contraction in the absence of all nerves. Thus any substance, such as a therapeutic drug, may affect any given secretion, in various ways, viz. (1) by dilating the blood-vessels and increasing the blood-supply, (2) by acting as a direct chemical stimulus on the protoplasm, (3) by exciting secretion in the cell through reflex action of the nervous mechanism belonging to the cell, (4) by acting directly on the nervous centre of that mechanism. We shall return to these questions when we come to speak of the secretion of urine.

We are now in a position to attack the second problem. What is the exact nature of the activity which is thus called forth?

We learn from the researches of Heidenhain⁴ that each secreting cell of a pancreas of an animal (dog) which has been fasting for 30 hours or more consists of two zones: an inner zone, next to the lumen of the alveolus, which is studded with fine granules, and a smaller outer zone, which is homogeneous or marked with delicate striæ. Carmine stains the outer zone easily, the inner zone with difficulty. The nucleus, more or less irregular in shape, is placed partly in the one and partly in the other zone. When however the pancreas of an animal in full digestion (about six hours after food and onwards) is examined, the outer

¹ Pflüger's *Archiv*, x. (1875) 557.

² *Centrb. Med. Wiss.*, 1868, p. 209.

³ *Wien. Sitzungsbericht*. L. p. 77.

⁴ *Op. cit.*

homogeneous zone is found to be much wider, the granular inner zone being correspondingly narrower, and in some cases actually disappearing. The whole cell is smaller, and owing to the relatively larger size of the outer zone, stains well. The nucleus is spherical and well formed. If the pancreas be examined at the end of digestion, the outer zone is again found to be narrow, the granular inner zone occupying the greater part of the cell, which in consequence stains with difficulty; and the whole cell has once more become larger. There seems to be but one interpretation of these facts. During the time that the pancreas is secreting most rapidly, there is a diminution of the inner zone; that is to say, the inner zone furnishes material for the secretion. But while the inner zone is diminishing, the outer zone is increasing, that is to say, the outer zone is being built up again out of materials brought to it from the blood, though not to such an extent as to prevent the whole cell from becoming smaller. When digestion is ended, after the pancreas has ceased to secrete, the inner zone again enlarges, evidently at the expense of the outer zone, though the latter also continues to increase, causing the whole cell to become bigger. From thence till the next meal, there occurs a partial consumption of the inner zone, so that the outer zone becomes more conspicuous again, though the whole cell becomes smaller. Evidently the outer homogeneous zone is formed at the expense of the blood, the inner granular zone at the expense of the outer zone, and the secretion at the expense of the inner zone.

Kühne and Lea¹ observing, under the microscope, the pancreas of the living rabbit, have been able to watch the actual process of secretion; and their results, while they extend, in the main corroborate those of Heidenhain. In the quiescent pancreas of the rabbit, the cells are for the most part filled with granules, the transparent outer zone being reduced to small dimensions; the outlines of the individual cells are very indistinct with the margins of the alveoli smooth; and the blood-supply is scanty. Upon secretion being set up, the margins of the active alveoli become indented through a bulging of their constituent cells, the outlines of which now become distinct; the granules retreat towards the inner zone, bordering on the cavity of the alveolus, and as secretion goes on, evidently diminish in number, the whole cell becoming hyaline and transparent from the outer border inwards; while the blood-vessels dilate largely, and the stream of blood through the capillaries becomes full and rapid.

We have already seen, p. 204, that in order to obtain an actively proteolytic aqueous pancreatic extract, the animal must be killed during full digestion. This statement now requires modification.

If the pancreas of an animal, even in full digestion, be treated, *while still warm from the body*, with glycerine, the glycerine extract is inert or nearly so as regards proteid bodies. If, however, the same pancreas be kept for 24 hours before treating with glycerine, the gly-

¹ *Verhandl. Naturhist. Med. Vereins, Heidelberg, Bd. I. (1877) Hft. 5.*

cerine extract readily digests fibrin and other proteids in the presence of an alkali. If the pancreas, while still warm, be rubbed up in a mortar for a few minutes with dilute acetic acid, and then treated with glycerine, the glycerine extract is strongly proteolytic. If the glycerine extract obtained without acid from the warm pancreas, and therefore inert, be diluted largely with water, and kept at 35° C. for some time, it becomes active. If treated with acidulated instead of distilled water, its activity, as judged of by its action on fibrin in the presence of sodium carbonate, is much sooner developed. If the inert glycerine extract of warm pancreas be precipitated with alcohol in excess, the precipitate, inert as a proteolytic ferment when fresh, becomes active when exposed for some time in an aqueous solution, rapidly so when treated with acidulated water. These facts shew that a pancreas taken fresh from the body, even during full digestion, *contains but little ready-made ferment*, though there is present in it a body which, by some kind of decomposition, *gives birth to the ferment*. They further shew that though the presence of an alkali is essential to proteolytic action of the actual ferment, the formation of the ferment out of the body in question is favoured by the presence of an acid. To this body, this mother of the ferment, Heidenhain has given the name of *Zymogen*¹. It has not at present been satisfactorily isolated.

Hence, in judging of the functional activity of the pancreas under various circumstances, we must look to not the ready-made ferment, but the ferment-giving zymogen. And Heidenhain has made the important observation that the amount of zymogen in a pancreas at any given time rises and sinks *pari passu* with the granular inner zone. The wider the inner zone, the larger the amount of zymogen; the narrower the zone, the smaller the amount; and in the cases of so-called paralytic secretions from old-established fistulæ, where the juice is wholly inert over proteids, the inner granular zone is absent from the cells. Evidently so far from the proteolytic ferment being simply drained off from the blood, in the first place the actual ferment is formed in the pancreas out of the zymogen, and in the second place the zymogen of the inner granular zone is formed in the cell itself out of the homogeneous outer zone. We have in fact two distinct processes to deal with: (1) the manufacture of zymogen; this is part of the growth or nutrition of the cell, and is slow and continued; (2) the splitting up or conversion of the zymogen into the proteolytic ferment; this is the real act of secreting, and is intermittent and rapid; this is the form of activity which can be called forth by nervous impulses, the form of activity which is comparable to a muscular contraction.

The thought at once suggests itself that the appearance of an acid in the protoplasm of the cell under circumstances similar to those which give

¹ Or zymogen may be reserved as a generic name for 'mother of ferment;' in that case the particular mother of the pancreatic proteolytic ferment might be called *trypsinogen*.

rise to the acid formed during muscular contraction, might be the immediate cause of the zymogen becoming converted into ferment.

In the case, then, of the proteolytic ferment of the pancreas we have striking proof that the process of secretion, both in its preparatory and executive stages, is a laborious, active, manufacturing function of the cell, and not simply a passive, selective, filtering function. How far this is also true of the other ferments of the pancreas, and of the active constituents of the other digestive juices, cannot at present be authoritatively affirmed, but we have, both in the case of the stomach and of the salivary glands, facts pointing very distinctly in that direction.

In the gastric glands of a starving animal, the central (as distinguished from the ovoid or 'peptic') cells are pale, and finely granular, and do not stain readily with carmine and other dyes. During gastric digestion, the same cells are found crumpled, darker, and more granular; they stain much more readily. This is true, not only of the central cells of the so-called peptic glands, but also of the cells of which the so-called mucous glands are exclusively built up. (The ovoid or peptic cells themselves during digestion appear swollen, and project more on the outside of the gland, but otherwise appear unchanged.) Evidently, during digestion, the central cells become loaded with a granular, more deeply staining proteid material, which probably arises from a transformation of the protoplasm of the cells.

In the mucous glands such as those abundant in the pylorus there is seen in the lumen also of the gland a granular material, which, since it makes its appearance after the mechanical stimulation of the membrane of an empty stomach, cannot, when it occurs during digestion, be regarded as simply digested food about to be absorbed. The granular character of the cells themselves therefore must also come from within, and cannot be due to material absorbed from the cavity of the stomach.

It will be observed that the phenomena of the gastric cells are different from those of the pancreatic cells. In the case of the pancreatic cell it is the part of the cell which contains the granules which does not stain readily; and the granules make their appearance during rest, and disappear upon stimulation. In the case of gastric central cells, it is when the cell becomes loaded with granules that it stains most deeply, and it becomes loaded with granules not during rest but during stimulation, or at least when the stomach is digesting. The observations of Kühne and Lea shew that in the pancreas the granules are actually used up to form the secretion. If in the gastric cell the granules are really elements of the secretion, they must during active digestion be formed more rapidly than they are used up, and must cease to be formed as the work of digestion languishes.

We have a certain amount of, but not wholly satisfactory, evidence of the existence of a mother of pepsin, or pepsinogen, comparable to the pancreatic zymogen. There has been a great dispute as to whether the pyloric end of the stomach, that containing the so-called mucous glands only, has peptic powers. The reconciliation of contradictory statements may perhaps be found in the fact¹, that while the glycerine extract of the fresh pylorus,

¹ Ebstein and Grützner, *Pflüger's Archiv*, VIII. (1874), p. 122.

even in the presence of free hydrochloric acid, is inert, care being taken to avoid admixture with the secretion of the cardiac end, an acid infusion of the same part rapidly becomes peptic. It would seem as if here, as in the case of zymogen, an acid is favourable to the conversion of the pepsinogen into pepsin. Apparently however, pepsinogen differs from zymogen in being insoluble in glycerine, while the latter is, as we have seen, freely soluble in that fluid. The subject requires to be more fully worked out.

We may therefore with good reason suppose that pepsin is formed by the direct activity of the gastric cells; and in that case the pepsin which is present in blood¹, in muscle and in urine², is not the source of the pepsin in the gastric juice, but is already-used pepsin reabsorbed from the stomach and intestine, and on its way to be discharged from the body. The formation of the free acid of the gastric juice is very obscure. It seems natural to suppose that it arises in some way from the decomposition of sodium chloride, but nothing definite can at present be stated as to the mechanism of that decomposition, or as to what are the mutual relations between the genesis of the acid and that of the pepsin.

If the reaction of the mucous membrane of the stomach be tested at different depths from the surface, as in the long tubular glands of a bird, it will be seen that the acidity is confined to the upper portion, indeed to the mouths, of the glands. So also when potassium ferrocyanide and an iron salt are injected into the veins, a blue colour is developed only on the surface of the mucous membrane, and not in the depths of the gland, shewing that an acidity sufficient to allow of the development of the blue is present only at the surface. These facts are opposed to Heidenhain's suggestion, that while the central cells manufacture pepsin, the large ovoid (peptic) cells (which lie chiefly in the middle of the gland) are given up to the production of acid³.

In the case of some of the salivary glands, for instance the submaxillary gland of the dog, the simpler events leading to the appearance of the ferment are obscured by processes having apparently for their object the production of mucus. When a section is prepared of a resting submaxillary gland of the dog, *i. e.* of a gland which for some time has not been actively secreting, the cells of the alveoli are found not to stain readily with carmine; and this lack of staining appears to be due to the fact that the greater part of the protoplasm of the cells has become converted into a mucin-bearing substance, only a small portion of unchanged protoplasm, easily staining with carmine, remaining round the nucleus. In addition to these 'muciparous cells' are seen a number of smaller half-moon-shaped (demilune) cells, the protoplasm of which stains deeply with carmine. These

¹ The presence of pepsin in blood is one reason why boiled fibrin should be used in peptic experiments rather than raw. The boiling destroys the pepsin clinging to the fibrin.

² Brücke, Moleschott's *Untersuch.* vi. 479.

³ Cf. however Swiecicki, *Pflüger's Archiv*, XIII. (1876) p. 444. Partsch, *Archiv f. Micros. Anat.* XIV. (1877) 179.

half-moon cells, which lie outside the muciparous cells, between them and the basement membrane, are apparently young cells, frequently possess two or more nuclei, and in general seem to be in a state of active growth and multiplication.

When similar sections are prepared from glands which have been thrown into long continued activity by stimulation of the chorda, the muciparous portion of the alveolar cells, that portion which does not stain rapidly, is found to have diminished, and the protoplasmic staining portion to have increased in quantity in proportion to the amount of stimulation. In some cases no muciparous cells can anywhere be seen; all the cells are alike composed of protoplasm, and all stain deeply. It has been disputed whether a muciparous cell simply discharges its mucin, the removal of the mucin being followed by a growth of the protoplasm round the nucleus, to be in turn followed by a new development of mucin, the same cell thus forming and discharging mucin again and again; or whether the whole cell goes to pieces at the time it discharges the mucus, its place being taken by one of the half-moon cells, which grows up rapidly for that purpose. In all probability both events occur at least after prolonged stimulation, the simple discharge of mucus and regeneration of the cell being analogous to what takes place in the pancreas, while the substitution of the young half-moon cell, in place of the old disintegrated muciparous cell, being something special to the submaxillary gland.

When a flow of saliva is brought by stimulation of the sympathetic similar changes may be observed, and they are also seen, though to a less extent, in the case of a paralytic secretion¹. In the submaxillary gland of the rabbit no such muciparous cells are to be seen, and no obvious differences have as yet been discovered between the cells of the gland at rest and those of the gland at work. If changes similar to those seen in the pancreas do take place, they are not such as can be readily seen in sections of prepared glands.

The submaxillary gland of the dog may be taken as a type of what have been called 'mucous glands', from the presence of muciparous cells in the gland, and mucin in the secretion. The submaxillary gland of the rabbit may be taken as a type of what have been called 'serous glands,' from the absence of muciparous cells in the gland, and of mucin in the secretion. Some glands, such as the submaxillary of man, may be regarded as mixed glands², *i.e.* partly mucous and partly serous.

What relation these changes bear to the production of the amylolytic ferment is unknown; it must, however, be remembered, as we stated above (p. 187), that the amylolytic ferment is in many animals absent, and in all a subordinate constituent of the secretion.

Relying on the analogy of the pancreas, we may fairly assume that the secretion of even such a complex fluid as the bile, is in the main the result of the direct metabolic activity of the protoplasm of

¹ Heidenhain, *op. cit.*

² Cf. Lavdowsky, *Archiv f. Micros. Anat.* XIII. (1877), 281.

the hepatic cells. And this view is supported by the fact that after extirpation of the liver, no accumulation of the biliary constituents is observed to take place during the few hours of life remaining to the animal after the operation. Still the great complexity of the secretion introduces several very important considerations. In the first place, the liver, unlike the other digestive glands, has a double supply of blood; and vain attempts have been made to settle by direct experiment the question whether the hepatic artery or the vena portæ is the more closely concerned in the production of bile. Ligature of the hepatic artery has sometimes had no effect on the secretion, sometimes has interfered with it. Sudden ligature of the vena portæ at once stops the flow of bile; but gradual obliteration may be effected without either causing death or even interfering with the secretion, anastomotic branches forming a collateral circulation and thus maintaining an efficient flow of blood through the liver. The problem, which is probably a barren one, cannot be settled in this way.

In the second place, the hepatic cells not only secrete bile, but as we shall see later on, take an active part in other operations of even greater importance. The consideration of the question in what way these several functions of the hepatic cells are related to each other must be deferred for the present.

In the third place, even if we maintain that the chief constituents of the bile are manufactured in the hepatic cells, and not simply drained off from the blood, we are not thereby precluded from admitting that the hepatic cells may avail themselves of certain half-made materials, the arrival of which in the blood may so to speak lighten their labours, or that they may even boldly seize upon and pass off as their own handiwork any wholly manufactured constituents which may be offered to them. Thus we have already seen reasons for thinking that the bile-pigments are not made *de novo* in the hepatic cells, but spring from hæmoglobin, the change in the liver being simple transformation. So also it is quite possible, though not proved, that much if not all of the cholesterin of bile is merely withdrawn by the liver from the body at large. And even with the central components of bile, the bile salts, we know in the case of taurocholic acid, taurin is normally present in certain tissues, and that in the case of glycocholic acid, glycin, if not a normal constituent of any tissue, is present in the liver, since the liver can convert benzoic into hippuric acid, as we shall see in a succeeding section; so that the formation of these bodies by the hepatic cells may be limited to the production of cholalic acid and its conjugation with one or other of the above amido-acids. Moreover as a matter of fact, we find that the flow of bile from a biliary fistula is much increased by the injection of bile into the small intestine¹. This experiment renders it possible that some of the bile which in natural digestion is poured into the intestine is reabsorbed, and carried back to the liver to do duty over again.

¹ Schiff, Pflüger's *Archiv*, III. (1870), 398.

Possibly however, the effect may be explained by some more indirect action of the bile in the intestine.

In medical practice, distinction is drawn between jaundice by suppression of the secreting functions of the liver and jaundice by retention, brought about by an obstruction existing in some part of the biliary passages. The gravity of the symptoms in the first class of cases shews that an arrest or a too great diminution of the normal functions of the hepatic cells is at least accompanied by the presence in the blood of substances injurious to life; but how far the presence of those substances is due to a failure of the manufacture of bile and the accumulation in the system of the materials for the formation of bile, or to a failure of other functions of the hepatic cells, must be regarded as at present undetermined. The presence of the bile-pigment in this form of jaundice would seem to indicate that the formation of the pigment, *i. e.* the transformation of hæmoglobin into bilirubin, requires but little labour on the part of the cell, and may be carried on even when the protoplasm of the cell is highly deranged.

Seeing the great solvent power of both gastric and pancreatic juice, the question is naturally suggested, Why does not the stomach digest itself? After death, the stomach is frequently found partially digested, viz. in cases when death has taken place suddenly on a full stomach. In an ordinary death, the membrane ceases to secrete before the circulation is at an end. That there is no special virtue in living things which prevents their being digested is shewn by the fact, that the legs of a frog or the ear of a rabbit introduced into a gastric fistula are readily digested. Dr Pavy¹ has suggested that the blood-current keeps up an alkalinity sufficient to neutralize the acidity of the juice; and he shews by experiment that tracts of the gastric membrane, from which the circulation is cut off, are digested. But tracts so cut off soon die, they lose not only the alkalinity of the blood but also all their powers; and the alkalinity of the blood will not explain why the mouths of the glands which are acid are not digested, or why the pancreatic juice, which is active in an alkaline medium, does not digest the proteids of the pancreas itself, or why the gastric membrane of the bloodless actinozoön or hydrozoön does not digest itself. We might add, it does not explain why the amœba, while dissolving the protoplasm of the swallowed diatom, does not dissolve its own protoplasm. We cannot answer this question at all at present, any more than the similar one, why the delicate protoplasm of the amœba resists during life all osmosis, while a few moments after it is dead, osmotic effects become abundantly evident.

SEC. 3. THE MUSCULAR MECHANISMS OF DIGESTION.

From its entrance into the mouth until such remnant of it as is undigested leaves the body, the food is continually subjected to movements having for their object the trituration of the food as in mastication, or its more complete mixture with the digestive juices, or its forward progress through the alimentary canal. These various movements may briefly be considered in detail.

¹ *Proc. Roy. Soc.* XII. 386, 559.

Mastication. Of this it need only be said that in man it consists chiefly of an up and down movement of the lower jaw, combined, in the grinding action of the molar teeth, with a certain amount of lateral and fore and aft movement. The lower jaw is raised by means of the temporal masseter and internal pterygoid muscles. The slighter effort of depression brings into action chiefly the digastric muscle, though the mylohyoid and geniohyoid probably share in the matter. Contraction of the external pterygoids pulls forward the condyles, and thrusts the lower teeth in front of the upper. Contraction of the pterygoids on one side will also throw the teeth on to the opposite side. The lower horizontally placed fibres of the temporal serve to retract the jaw.

During mastication the food is moved to and fro, and rolled about by the movements of the tongue. These are effected by the muscles of that organ governed by the hypoglossal nerve.

The act of mastication is a voluntary one, guided, as are so many voluntary acts, not only by muscular sense but also by contact sensations. The motor fibres of the fifth cranial nerve convey motor impulses from the brain to the muscles; but paralysis of the sensory fibres of the same nerve renders mastication difficult by depriving the will of the aid of the usual sensations.

Deglutition. The food when sufficiently masticated is, by the movements of the tongue, gathered up into a bolus on the middle of the upper surface of that organ. The front of the tongue being raised—partly by its intrinsic muscles, and partly by the styloglossus—the bolus is thrust back between the tongue and the palate through the anterior pillars of the fauces or *isthmus faucium*. Immediately before it arrives there, the soft palate is raised by the levator palati, and so brought to touch the posterior wall of the pharynx, which, by the contraction of the upper margin of the superior constrictor of the pharynx, bulges somewhat forward. The elevation of the soft palate causes a distinct rise of pressure in the nasal chambers; this can be shewn by introducing a water manometer into one nostril, and closing the other just previous to swallowing. By the contraction of the palato-pharyngeal muscles which lie in the posterior pillars of the fauces, the curved edges of those pillars are made straight, and thus tend to meet in the middle line, the small gap between them being filled up by the uvula. Through these manœuvres, the entrance into the posterior nares is blocked, while the soft palate forms a sloping roof, guiding the bolus down the pharynx. By the contraction of the stylo-pharyngeus and palato-pharyngeus, the funnel-shaped bag of the pharynx is brought up to meet the descending morsel, very much as a glove may be drawn up over the finger.

Meanwhile in the larynx, as shewn by the laryngoscope, the arytenoid cartilages and vocal cords are approximated: the latter being also raised so that they come very near to the false vocal cords: the

cushion at the base of the epiglottis covers the rima glottidis, while the epiglottis itself is depressed over the larynx. The thyroid cartilage is now, by the action of the laryngeal muscles, suddenly raised up behind the hyoid bone, and thus assists the epiglottis to cover the glottis. This movement of the thyroid can easily be felt on the outside. Thus, both the entrance into the posterior nares and that into the larynx being closed, the impulse given to the bolus by the tongue can have no other effect than to propel it beneath the sloping soft palate, over the incline formed by the root of the tongue and the epiglottis, into the grasp of the constrictor muscles of the pharynx: the palato-glossi or constrictores isthmi faucium, which lie in the anterior pillars of the fauces, by contracting, close the door behind the food which has passed them. The morsel being now within the reach of the constrictors of the pharynx, these contract in sequence from above downwards, and thus necessarily thrust the food into the œsophagus.

Deglutition therefore, though a continuous act, may be regarded as divided into three stages. The first stage is the thrusting of the food through the isthmus faucium; this being a voluntary act, may be either of long or short duration. The second stage is the passage through the upper part of the pharynx. Here the food traverses a region common both to the food and to respiration, and in consequence the movement is as rapid as possible. The third stage is the descent through the grasp of the constrictors. Here the food has passed the respiratory orifice, and in consequence its passage may again become comparatively slow.

The first stage in this complicated process is undoubtedly a voluntary action; the raising of the soft palate and the approximation of the posterior pillars must also be in a measure voluntary, since they were seen, in a case where the pharynx was laid bare by an operation, to take place before the food had touched them¹; but they may take place without any exercise of the will or presence of consciousness, and indeed the whole part of the act of deglutition which follows upon the passing of the food through the anterior pillars of the fauces must be regarded as a reflex act: though some of the earlier component movements are, as it were, on the borderland between the voluntary and involuntary kingdoms. The constricting action of the constrictors on the other hand is purely reflex; the will has no power whatever over it; it cannot either originate, stop, or modify it.

Deglutition as a whole is a reflex act and cannot take place unless some stimulus be applied to the mucous membrane of the fauces. When we voluntarily bring about swallowing movements with the mouth empty, we supply the necessary stimulus by forcing with the tongue a small quantity of saliva into the fauces, or by touching the fauces with the tongue itself.

¹ Brücke, *Vorlesungen*, i. p. 281.

In the reflex act of deglutition the afferent impulses originated in the fauces are carried up chiefly by the glosso-pharyngeal, but also by branches of the fifth, and by the pharyngeal branches of the superior laryngeal division of the vagus. The efferent impulses descend the hypoglossal to the muscles of the tongue, and pass down the glosso-pharyngeal, the vagus through the pharyngeal plexus, the fifth and the facial, to the muscles of the fauces and pharynx: their exact paths being as yet not fully known, and probably varying in different animals. The laryngeal muscles are governed by the laryngeal branches of the vagus.

The centre of the reflex act lies in the medulla oblongata. Deglutition can be excited, by tickling the fauces, in an animal rendered unconscious by removal of the brain, provided the medulla be left. If the medulla be destroyed, deglutition is impossible. The centre for deglutition lies higher up than that of respiration, so that the former act is frequently impaired or rendered impossible while the latter remains untouched. It is probable that, as is the case in so many other reflex acts, the whole movement can be called forth by stimuli affecting the centre directly, and not acting on the usual afferent nerves.

As each successive segment of the pharyngeal constrictors contracts in sequence from above downwards, the bolus is carried down into the upper end of the œsophagus. Here it is subjected to the influence of a peculiar muscular action known as 'peristaltic.' Since this kind of muscular action is, with local variations, characteristic of the whole alimentary canal from the beginning of the œsophagus to the end of the rectum, it will be of advantage to disregard the strict topographical order of events, and to consider, first of all, the movement in that part of the canal where it is comparatively simple in nature, and has been best studied: viz. in the small intestine; and afterwards to deal with the variations occurring in particular places and under special circumstances.

Peristaltic action of the small Intestine. We have already seen, in treating of unstriated muscular fibre (p. 82), that a stimulus applied to any part of the small intestine gives rise to a circular contraction, or contraction of the circular muscular coat, which travels lengthways as a wave along the intestine, and also to a longitudinal contraction, or contraction of the longitudinal coat, which similarly travels lengthways as a wave along the intestine. Since the circular coat is much thicker than the longitudinal one, the circular wave is more powerful and more important than the longitudinal one; the circular coat has by far the greater share in propelling the food along the intestine. It is obvious that a circular contraction travelling down the intestine (and in the natural state of things it does travel downwards, and not both upwards and downwards) must drive the contents of the intestine onwards towards the cæcum. And practically when the intestines are watched after opening the

abdomen, the contents are seen to be thus thrust onward by the contraction of the circular coat. This onward movement of the food, caused by the circular coat, may be assisted by the contraction of the longitudinal coat. A longitudinal contraction, preceding at any spot the circular contraction, will necessarily shorten, and so widen, the segment of the intestine in which it takes place, and therefore facilitate the progress into that segment of the contents which are being pressed into it by the circular contraction of the preceding segment. Thus both forms of contraction tend to drive the food onward. It is probable, however, that they may occur independently; and it must be remembered that both these kinds of contraction have as their result, in the small intestine at least, not only the progress of the digested food, but also the locomotion to a certain extent of the intestine itself. When the abdomen is opened, what is seen is not so much the onward progress of the contents of the canal as the confused writhing of the intestines themselves. This arises from the intestine being arranged in pendent loops, so that the impulse given to the fluid contents reacts upon the tube itself, and causes locomotion not only in the loop where contraction is taking place, but also in preceding and following loops from which contents are drawn, or into which they are driven. The longitudinal contractions occurring and recurring in a loop cause peculiar oscillating movements of the loop.

The movements, as we have said, take place from above downwards, and a wave beginning at the pylorus may be traced a long way down. But contractions may, and in all probability occasionally do, begin at various points along the length of the intestine. In the living body the intestines have periods of rest, alternating with periods of activity, the occurrence of the periods depending on various circumstances.

With regard to the causation of the peristaltic movements of the intestine, this much may be affirmed. They may occur, as in a piece of intestine cut out from the body, wholly independently of the central nervous system. The only nervous elements which can be regarded as essential to their development are the ganglia of Auerbach or those of Meissner in the intestinal walls.

Though peristaltic movements can readily be excited by stimuli, applied either to the outside, or, more especially, to the inside of the intestine, they are probably at bottom automatic. The presence of food, especially of food in motion, may at times act as a stimulus, and may in all cases be a condition affecting the nature and extent of the movement; but cannot be regarded as the real cause of the action. When any body is introduced into the intestine, a contraction at first occurs, but soon passes off as the intestine becomes accustomed to the presence of the body. There is no reason why the intestine should not become equally accustomed to the presence of food; and, as a matter of fact, peristaltic movements are often absent when the intestines are full. The presence of food bears about the same relation to the movements of the intestine, that the presence of blood

bears to the beat of the heart. Both are favouring but not indispensable conditions: in both cases the action can go on without them. We may add that just as the tension of a muscle increases up to a certain extent the amount of its contraction, and a full heart beats more strongly than an empty one, so distension of the intestine largely increases peristaltic action. Hence in cases of obstruction of the bowels, the movements become distressing by their violence.

Among the chief circumstances affecting peristaltic action may be mentioned in the first place the condition of the blood. A lack of oxygen or an excess of carbonic acid in the blood excites powerful movements. This is well seen in asphyxia, and the post-mortem peristaltic movements witnessed on opening a recently-killed animal, are probably due to the deficiency of oxygen or the accumulation of carbonic acid in the blood and tissues of the intestinal walls. Conversely, saturation of the blood with oxygen, as in the peculiar condition known as apnoea (see chapter on Respiration), tends to check peristaltic movements.

Judging from the analogy of the respiratory and other nervous centres the effects should be attributed to variations in the quantity of oxygen rather than of carbonic acid; this however does not at present seem clearly proved.

In the second place, peristaltic action is largely influenced by nervous influences passing along the splanchnic and vagus nerves. The movements will go on after section of both these nerves; but as a general rule, while stimulation of the splanchnic tends to check¹, that of the vagus tends to excite them. It is probably through the vagus that peristaltic movements can be effected in a reflex manner, as in that increase of the movements of the intestine in consequence of emotions, which has given rise to the phrase 'my bowels yearned.'

It is generally stated that sudden stoppage of the blood-current excites peristaltic action, the explanation given being that, as after general death, there is an accumulation of carbonic acid and a lack of oxygen in the intestinal tissues. Van Braam Houckgeest², however, states, on the contrary, that it brings the intestine to rest; and Nasse³ found that the injection of arterial blood at a high pressure, caused very powerful movements. On the other hand, exposure to air has been considered as an exciting cause of the movements; and undoubtedly a very large amount of movement may frequently be observed, on laying open the abdomen, even in animals whose circulation is active. Since however the movements continue when the body is immersed in weak sodium chloride solution and the intestine thereby excluded from direct contact with air, they cannot be attributed to mere exposure. If the splanchnic nerve be stimulated while active movement is going on, the intestine is undoubtedly brought to rest. Since at the same time the blood-vessels of the intestine are by the vaso-constrictor action of the splanchnic constricted, the quiescence of the intestine may be

¹ Pflüger, *Die Hemmungsnerven des Darms*, 1857.

² Pflüger's *Archiv*, vi. (1872) 266.

³ *Beitr. z. Physiol. d. Darmbewegungen*, 1866.

indirectly due to insufficient blood-supply¹. Houtkeest however denies this, on the ground that when by exposure to the air the blood-vessels of the intestine are so far paralysed as to be no longer constricted by the action of the splanchnic, quiescence of the intestine is still observed on irritating that nerve. The splanchnic thus appears to be a direct inhibitory nerve as regards peristaltic action, while the vagus is undoubtedly an adjuvant or accelerator nerve. It is stated that after section of the splanchnics peristaltic movements are more active and more readily brought about by stimulation of the vagus than when the splanchnics are entire. According to Ludwig², however, stimulation of the splanchnic, while it stops an already-developed peristaltic action, will bring on the movement when brought to bear on an intestine previously at rest.

When the vagus is stimulated, peristaltic contraction is seen to begin at the pylorus of the stomach and so to descend along the intestine. It has been stated that no so-called antiperistaltic action, that is, a wave of contraction passing upwards instead of downwards along the intestine, ever occurs naturally in the intestine, the backward flow undoubtedly seen when an obstruction exists being explained as being simply due to a central return current. When however the duodenum is mechanically stimulated both a peristaltic and an antiperistaltic wave may be observed, the former passing downward and ceasing at the ileo-cæcal valve if not before, the latter passing up and ceasing at the pylorus. And when in the exposed intestines a wave, as occasionally happens, begins spontaneously in the duodenum, it may sometimes be seen to pass both upwards and downwards. It is worthy of notice that stimulation of the small intestine is said not to cause movement either in the stomach or large intestine, and stimulation of the large causes no movement of the small intestine, the ileo-cæcal valve and the pylorus barring the progress of the waves³.

Certain drugs, such as nicotin, (atropin, ergot,) induce strong peristaltic action; the modus operandi of these and of the more specific purgative drugs is at present uncertain.

Having thus studied the general characters of peristaltic action in its most marked form, we may briefly consider the same movement in other parts of the alimentary canal.

Movements of the Œsophagus. The descent of the food along the œsophagus is effected by a peristaltic contraction of the circular and longitudinal coats, resembling in its general characters that of the intestine. It differs however in being more closely dependent on the central nervous system, and may in fact be considered as being in large measure a reflex act, with the centre in the medulla oblongata, both afferent and efferent impulses being supplied by the vagus. It may be readily excited by stimulating the central end of the superior laryngeal nerve; and this nerve, since it is connected by its pharyngeal branch both with the mucous membrane of the pharynx and with the lower pharyngeal constrictor, may serve to inaugurate the œsophageal movement, by carrying afferent impulses started by the

¹ Basch, *Wien. Sitzungsbericht*, LVIII. (1873).

² *Lehrb.* II. p. 616.

³ Engelmann, *Pflüger's Archiv*, IV. (1871) 33.

presence of food in the pharynx or by the muscular act of swallowing. Section of the trunk of the vagus renders difficult the passage of food along the œsophagus, and stimulation of the peripheral stump causes œsophageal contractions. Hence the motor tracts of the reflex act are to be sought for in the vagus also. The force of this movement is considerable; thus Mosso¹ found that in the dog a ball pulling by means of a pulley against a weight of 250 grammes was readily carried down from the pharynx to the stomach.

Mosso² states that section and even removal of portions of the œsophagus do not prevent the progression of a peristaltic wave from the pharynx to the stomach, provided the reflex machinery of the medulla be intact. He argues in consequence that the natural movement in swallowing is entirely carried on by the medulla as a reflex act. Nevertheless an œsophagus according to his own account will when removed from the body, and therefore entirely separated from any extrinsic nervous mechanism, exhibit good peristaltic movements. The extrinsic central mechanism therefore would seem only to be useful in perfecting a movement which in its absence would be imperfect and inefficient.

Goltz³ has shewn that if in a urarized frog fluid be poured down the throat, both stomach and œsophagus will, after the first peristaltic movements carrying down the first portions of fluid have passed away, remain perfectly quiescent in an enormously distended condition (the contraction of the pylorus preventing the descent of the fluid into the duodenum), so long as the medulla oblongata and vagi are intact. Destruction of the medulla or section of the vagi gives rise to the development of abundant downward and upward peristaltic waves of contraction, by which the stomach becomes wrinkled and the top of the œsophagus closed; and these movements last as long as the irritability of the organs continues. During the quiescence observed with intact vagi and medulla, temporary peristaltic action may be induced by direct irritation of the vagus, or in a reflex manner through the medulla, by stimulation of the skin or intestine. Chauveau⁴ and Schiff⁵ also saw occasional movements in the œsophagus after section of the vagus. Goltz interprets his result by supposing that the movements are primarily caused by local motor centres in the œsophagus and stomach, habitually inhibited by the action of a centre in the medulla. Hence when this inhibition is removed by destruction of the medulla or section of the vagi, the energy of the local centres is free to act. Stimulation of the skin or other distant spots produces movements by depressing the medullary inhibitory centre. Stimulation of the vagus probably produces movements by directly augmenting the local centres.

The junction of the œsophagus with the stomach remains in a more or less permanent condition of tonic or obscurely rhythmic contraction, more particularly when the stomach is full of food, and thus serves as a sphincter to prevent the return of food from the stomach into the œsophagus.

¹ Moleschott's *Untersuch.* xi. (1874) 327.

² *Loc. cit.*

³ Pflüger's *Archiv*, vi. (1872), 616.

⁴ *Journal de Physiologie*, v. (1863) p. 337.

⁵ *Leçons sur la Physiologie de Digestion*, p. 377.

Movements of the Stomach. These are at bottom peristaltic in nature, though largely modified by the peculiar arrangement of the gastric muscular fibres. When food first enters the stomach, the movements are feeble and slight, but as digestion goes on they become more and more vigorous, giving rise to a sort of churning within the stomach, the food travelling from the cardiac orifice along the greater curvature to the pylorus, and returning by the lesser curvature, while at the same time subsidiary currents tend to carry the food which has been passing close to the mucous membrane towards the middle of the stomach, and *vice versa*. At the pyloric end strong circular contractions are set up, by which portions of food, more especially the dissolved parts, but also¹ small solid pieces, are carried through the relaxed sphincter into the duodenum. As digestion proceeds, more and more material leaves the stomach, which is thus gradually emptied, the last portions which are carried through being those matters which are least digestible, and foreign bodies which happen to have been swallowed. The presence of food then leads to the development of obscurely peristaltic rhythmic movements, the stomach when empty being contracted, but quiescent; but evidently it is not the mere mechanical repletion of the organ which is the cause of the movements, since the stomach is fullest at the beginning when the movements are slight, and becomes empty as they grow more forcible. The one thing which does increase *pari passu* with the movements is the acidity, which is at a minimum when the (generally alkaline) food has been swallowed, and increases steadily onwards. It has not however been definitely shewn that the increasing acidity is the efficient stimulus, giving rise to the movements.

The nervous mechanism of the gastric movements is very perplexing. Judging from the analogy of the intestine, one would imagine that they originated in the stomach itself, being modified but not directly caused by the action of the central nervous system. Spontaneous movements, however, of a stomach, whose nervous connections have been severed, even of a full one, are at least much more rare than those seen in the intestine or even in the œsophagus; and such movements as are occasioned by local mechanical or other stimulation are limited in extent, and rarely put on all the characters of the natural complex contractions. Since there are abundant ganglia in the walls of the stomach, it may fairly be doubted whether the automatic movements of the excised intestine are due to the action of ganglia, otherwise why should not the ganglia in the stomach set up spontaneous movements in that organ also? For if ganglia are par excellence the organs of automatic actions we should expect spontaneous movements to accompany their presence.

The stomach receives its nervous supply from the vagi and also from the solar plexus, with which the splanchnics are connected. When the vagi are divided, a spasmodic constriction of the cardiac orifice takes place, and food is thus prevented, for a time at least, from leaving the œsophagus.

¹ Kühne, *Lehrb.* i. 53.

This result is in harmony with the observations of Goltz on the frog. But the natural movements of the stomach itself cease, though the introduction of food after section of the vagi is said to cause some amount of contraction. They may be induced by stimulation of the peripheral stumps of the vagi, when the stomach is full, but not if it be empty. Neither section nor stimulation of the splanchnics or of the branches from the solar plexus produce, it is said, any effect on the stomach as far as its movements are concerned. Evidently the movements of the stomach, far more than those of the intestine, are dependent on and governed by the central nervous system, but the exact manner in which they are governed, and the proper share to be allotted to exciting and inhibitory mechanisms, remain yet to be discovered. The sort of tonic contraction, into which the walls of the stomach fall when its cavity is empty, does not occur in the intestine; and this feature probably modifies all the nervous working of the organ. Nor do we know the exact mechanism by which the pyloric sphincter is used to strain off gradually the more digested portions of the food. The movements of even a full stomach are said by Busch¹ to cease during sleep.

Movements of the large Intestine. These are fundamentally the same as those of the small intestine, but distinct in so far as the latter cease at the ileo-cæcal valve, at which spot the former normally begin.

They are said, however, not to be inhibited by stimulation of the splanchnics².

The fæces in their passage through the colon are lodged in the sacculi during the pauses between the peristaltic waves. Arrived at the sigmoid flexure, they are supported by the bladder and the sacrum, so that they do not press on the sphincter ani.

Defæcation. This is a mixed act, being superficially the result of an effort of the will, and yet carried out by means of an involuntary mechanism. Part of the voluntary effort consists in producing a pressure-effect, by means of the abdominal muscles. These are contracted forcibly as in expiration, but the glottis being closed, and the escape of air from the lungs prevented, the whole force of the pressure is brought to bear on the abdomen itself, and so drives the contents of the descending colon onward into the rectum. The sigmoid flexure is by its position sheltered from this pressure; a body introduced per anum into the empty rectum is not affected by even forcible contractions of the abdominal walls.

The anus is guarded by the sphincter ani, which is habitually in a state of normal tonic contraction, capable of being increased or diminished by a stimulus applied, either internally or externally, to the anus. The tonic contraction is in part at least due to the action of a nervous centre situated in the lumbar spinal cord³. If the nervous connection of the sphincter with the spinal cord be broken, relaxation takes place. If the spinal cord be divided in the dorsal

¹ Virch. *Archiv*, xiv. p. 166.

² Pflüger, *op. cit.*; Nasse, *op. cit.*

³ Masius, *Bull. de l'Acad. R. de Belgique*, xxiv. (1867), p. 312.

region, the sphincter, after the depressing effect of the operation, which may last several days, has passed off, still maintains its tonicity, shewing that the centre is not placed higher up than the lumbar region of the cord. The increased or diminished contraction following on local stimulation is probably due to a reflex augmentation or inhibition of the action of this centre. The centre is also subject to influences proceeding from higher regions of the cord, and from the brain. By the action of the will, by emotions, or by other nervous events, the lumbar sphincter centre may be inhibited, and thus the sphincter itself relaxed; or augmented, and thus the sphincter tightened. A second item therefore of the voluntary process in defæcation is the inhibition of the lumbar sphincter centre, and consequent relaxation of the sphincter muscle.

According to Goltz¹, in the dog after division of the dorsal cord, and consequent separation of the sphincter centre from the cerebrum, local stimulation, such as the introduction of the finger, causes not a steady increase or decrease of the action of the sphincter, but a rhythmic alternation of tightening and relaxing. The absence of this rhythm with an intact cord indicates some obscure action of the cerebral centres on the lumbar centre. The conversion of the tonic into the rhythmic action also illustrates the close relationship between these two kinds of movements.

Though the tonic contraction of the sphincter seems so largely dependent on the lumbar centre, still this dependence is probably not an absolute one. In the case of a man in whom as the result of injury the sacral nerves were entirely paralysed, and the sphincter accordingly had no nervous connection with the lumbar centre (unless there were a roundabout connection by means of the sympathetic), Gower² observed the maintenance of a certain amount of tonic contraction which could be inhibited, and relaxation induced, by stimulation of the mucous membrane of the rectum and anus. As in the case of the arteries, we have apparently to deal here with a tonic contraction which is habitually dependent on a spinal centre, but which may nevertheless exist without the action of that centre.

Since the lumbar centre is wholly efficient when separated from the brain, the paralysis of the sphincter which occurs in certain cerebral diseases is probably due to inhibition of this centre, and not to paralysis of any cerebral centre.

Thus a voluntary contraction of the abdominal walls, accompanied by a relaxation of the sphincter, might press the contents of the descending colon into the rectum and out at the anus. Since however, as we have seen, the pressure of the abdominal walls is warded off the sigmoid flexure, such a mode of defæcation would always end in leaving the sigmoid flexure full. Hence the necessity for these more or less voluntary acts being accompanied by an entirely involuntary augmentation of the peristaltic action of the large intestine and sigmoid flexure. Or rather, to describe matters in their proper order, defæcation takes place in the following manner. The sigmoid flexure and large intestine becoming more and more full, stronger

¹ Pflüger's *Archiv*, VIII. (1874), 460.

² *Proc. Roy. Soc.* XXVI. (1877), p. 77.

and stronger peristaltic action is excited in their walls. By this means the fæces are driven against the sphincter. Through a voluntary act, or sometimes at least by a simple reflex action, the lumbar sphincter centre is inhibited and the sphincter relaxed. At the same time the contraction of the abdominal muscles presses firmly on the descending colon, and thus the contents of the rectum are ejected.

It must however be remembered that, while in appealing to our own consciousness, the contraction of the abdominal walls and the relaxation of the sphincter seem purely voluntary efforts, the whole act of defæcation, including both of these seemingly so voluntary components, may take place in the absence of consciousness, and indeed, in the case of Goltz's dog¹, after the complete severance of the lumbar from the dorsal cord. In such cases the whole act must be purely reflex, excited by the presence of fæces in the rectum.

Vomiting. In a conscious individual this act is preceded by feelings of nausea, during which a copious flow of saliva into the mouth takes place. This being swallowed carries down with it a certain quantity of air, the presence of which in the stomach, by assisting in the opening of the cardiac sphincter, subsequently facilitates the discharge of the gastric contents. The nausea is generally succeeded at first by ineffectual retching in which a deep inspiratory effort is made, so that the diaphragm is thrust down as low as possible against the stomach the lower ribs being at the same time forcibly drawn in; since during this inspiratory effort the glottis is kept closed, no air can enter into the lungs; but some is drawn into the pharynx, and thence probably descends by a swallowing action into the stomach. In actual vomiting this inspiratory effort is succeeded by a sudden violent expiratory contraction of the abdominal walls, the glottis still being closed, so that the whole force of the effort is spent, as in defæcation, in pressure on the abdominal contents. The stomach is therefore forcibly compressed from without. At the same time, or rather immediately before the expiratory effort, by a contraction of its longitudinal fibres the œsophagus is shortened and the cardiac orifice of the stomach brought close under the diaphragm, while apparently by a contraction of the fibres which radiate from the end of the œsophagus over the stomach, the cardiac orifice, which is normally closed, is somewhat suddenly dilated. This dilation opens a way for the contents of the stomach, which, pressed upon by the contraction of the abdomen, and to a certain but probably only to a slight extent by the contraction of the gastric walls, are driven forcibly up the œsophagus, their passage along that channel being possibly assisted by the contraction of the longitudinal muscles. The mouth being widely open, and the neck stretched to afford as straight a course as possible, the vomit is ejected from the body. At this moment there is an additional expiratory effort which serves to pre-

¹ *Op. cit.*

vent the vomit passing into the larynx. In most cases too the posterior pillars of the fauces are approximated, in order to close the nasal passage against the ascending stream. This however in severe vomiting is frequently ineffectual.

Thus in vomiting there are two distinct acts; the dilation of the cardiac orifice and the extrinsic pressure of the abdominal walls in an expiratory effort. Without the former the latter, even when distressingly vigorous, is ineffectual. Without the latter, as in urari poisoning, the intrinsic movements of the stomach itself are rarely sufficient to do more than eject gas, and, it may be, a very small quantity of food or fluid. Pyrosis or waterbrash is probably brought about by this intrinsic action of the stomach.

During vomiting the pylorus is generally closed, so that but little material escapes into the duodenum. When the gall-bladder is full, a copious flow of bile into the duodenum accompanies the act of vomiting. Part of this may find its way into the stomach, as in bilious vomiting, the pylorus then being evidently open.

The experiment of Majendie, shewing that vomiting can take place when a simple bladder is substituted for the stomach, is said to fail unless the œsophageal sphincter be removed or the dilating mechanism be left intact. Schiff¹, by introducing his finger through a gastric fistula, was able to ascertain by direct touch, both the normal occlusion of the cardiac orifice, broken only during the descent of food, and its sudden dilation just preceding the expiratory pressure during vomiting. He found that when the muscular fibres radiating from the œsophagus over the stomach were injured, as by crushing them with a ligature forcibly applied for a few seconds, the constriction of the cardiac orifice remained permanent; dilation of the cardiac orifice, and in consequence vomiting, became impossible. He therefore regards the dilation as caused by the active contraction of these fibres, and not as due to inhibition of the normally contracted circular fibres. In order that the contraction of the radiating fibres should cause dilation, their ends distal from the œsophagus must be fixed. This is provided by the stomach being supported by the descent of the diaphragm. The support afforded to the œsophagus by the diaphragm as it passes through that muscle must also be of advantage, and the longer the portion of œsophagus between the diaphragm and the stomach, the greater will be the effect of the radiating muscles in pulling down the œsophagus instead of dilating its orifice. This is possibly the reason why the horse and other herbivorous animals vomit with such difficulty.

The nervous mechanism of vomiting is complicated and in many aspects obscure. The efferent impulses which cause the expiratory effort must come from the respiratory centre in the medulla; with these we shall deal in speaking of respiration. The dilation of the cardiac orifice is caused, in part at least, by efferent impulses descending the vagi, since when these are cut real vomiting with discharge of the gastric contents is difficult, through want of readiness in the dilation. The sympathetic abdominal nerves coming from

¹ Moleschott's *Untersuch.* x. (1870) 353.

the coeliac ganglia and the splanchnic nerves seem to have no share in the matter. The efferent impulses which cause the flow of saliva in the introductory nausea descend the facial along the chorda tympani branch. These various impulses may best be considered as starting from a vomiting centre in the medulla, having close relations with the respiratory centre. This centre may be excited, may be thrown into action, in a reflex manner, by stimuli applied to peripheral nerves, as when vomiting is induced by tickling the fauces, or by irritation of the gastric membrane, or by obstruction due to ligature, hernia, etc., of the intestine. That the vomiting in the last instance is due to nervous action, and not to any regurgitation of the intestinal contents, is shewn by the fact that it will take place when the intestine is perfectly empty and may be prevented by section of the mesenteric nerves. The vomiting attending renal and biliary calculi is apparently also reflex in origin. The centre however may be affected directly, as probably in the cases of some poisons, and in some instances of vomiting from disease of the medulla oblongata. Lastly, it may be thrown into action by impulses reaching it from parts of the brain higher up than itself, as in cases of vomiting produced by smells, tastes and emotions, and by the memory of past occasions, and in some cases of vomiting from cerebral disease.

Many emetics, such as tartar emetic, appear to act directly on the centre, since they will produce vomiting not only when introduced into the blood, but even when a bladder is substituted for the stomach. Others again, such as mustard and water, act in a reflex manner by irritation of the gastric mucous membrane. With others, again, which cause vomiting by developing a nauseous taste, the reflex action involves parts of the brain higher than the centre itself.

Since the *vagus* acts as an efferent nerve in causing the dilation of the cardiac orifice so essential to the act, it is difficult to eliminate the share taken by the *vagus* as an afferent nerve carrying up impulses from the stomach to the vomiting centre. The remarkable fact that, by giving tartar emetic, vomiting may in dogs be sometimes induced, even after section of the *vagi*, shews that the dilation of the cardiac orifice, though normally effected through the *vagus*, may be carried out by means of some local mechanism, and that the emetic may also stimulate that local mechanism at the same time that it is affecting the general centre. ✓

SEC. 4. THE CHANGES WHICH THE FOOD UNDERGOES IN THE ALIMENTARY CANAL.

Having studied the properties of the digestive juices, and the various mechanisms by means of which the food is brought under their influence, we have now to consider what, as matters of fact, are the actual changes which the food does undergo in passing along the alimentary canal, what are the steps by which the food is converted into *fæces*.

In the mouth the presence of the food, assisted by the movements of the jaw, causes, as we have seen, a flow of saliva. By mastication, and by the addition of mucous saliva, the food is broken into small pieces, moistened, and gathered into a convenient bolus for deglutition. In man some of the starch is, even during the short stay of the food in the mouth, converted into sugar; for if boiled starch free from sugar be even momentarily held in the mouth, and then ejected into water (kept boiling to destroy the ferment), it will be found to contain a decided amount of sugar. In many animals no such change takes place. The viscid saliva of the dog serves almost solely to assist in deglutition; and even the longer stay which food makes in the mouth of the horse is insufficient to produce any marked conversion of the starch it may contain. During the rapid transit through the **oesophagus** no appreciable change takes place.

In the stomach, the arrival of the food, the reaction of which is either naturally alkaline, or is made alkaline, or at least is reduced in acidity, by the addition of saliva, causes a flow of gastric juice. This already commencing while the food is as yet in the mouth, increases as the food accumulates in the stomach, and as, by the churning gastric movements, unchanged particles are continually being brought into contact with the mucous membrane. Hence the reaction of the gastric contents becomes more and more distinctly acid as digestion proceeds. The change of starch into sugar is lessened or perhaps arrested. The fats themselves remain unchanged; but, through the conversion of proteids into peptone, not only are the more distinctly proteid articles of food, such as meat, broken up and dissolved, but the proteid framework, in which the starch and fats are frequently imbedded, is loosened, the starch-granules are set free, and the fats, melted for the most part by the heat of the stomach, tend to run together in large drops, which in turn are more or less apt to be broken up into an imperfect emulsion. The collagenous tissues are dissolved; and hence the natural bundles of meat and vegetables fall asunder; the muscular fibre splits up into discs, and the protoplasm is dissolved from the vegetable cells. While these changes are proceeding, the thick turbid greyish liquid or chyme, formed by the imperfectly dissolved food, is from time to time ejected through the pylorus, accompanied by even large morsels of solid less-digested matter. This may occur within a few minutes of food having been taken, but the larger escape from the stomach probably does not begin till from one to two, and lasts from four to five, hours after the meal, becoming more rapid towards the end, such pieces as most resist the gastric juice being the last to leave the stomach.

In the presence of healthy gastric juice, and in the absence of any nervous interference, the question of the digestibility of any food is determined chiefly by mechanical conditions. The more

finely divided the material, and the less the proteid constituents are sheltered by not easily soluble envelopes, such as those of cellulose, the more rapid the solution. So also pieces of hard-boiled egg, which have to be gradually dissolved from the outside, are less easily digested than the more friable muscular fibre, the repeated transverse cleavage of which increases the surface exposed to the juice. Unboiled white of egg again, unless thoroughly beaten up and mixed with air, is less digestible than the same boiled. The unboiled white forms a viscid clotted mass, of low diffusibility, into which the juice permeates with the greatest difficulty. And so with other instances. Beyond this mechanical aspect of digestibility, it is to be remembered that different substances may differently affect the gastric membrane, promoting or checking the secretion of the juice. Hence a substance, the mass of which is readily dissolved by gastric juice, and which offers no mechanical obstacles to digestion, may yet prove indigestible by so affecting the gastric membrane through some special constituent (or possibly in other ways) as to inhibit the secretion of the juice.

That substances can be absorbed from the cavity of the stomach into the circulation is proved by the fact that food when introduced disappears very largely from the stomach of an animal, the pylorus of which has been ligatured. But we cannot speak with certainty as to what extent in ordinary life gastric absorption takes place, or by what mechanism it is carried out. The presumption is, that the diffusible sugars and peptone pass by osmosis direct into the capillaries, and so into the gastric veins. The filtrate of chyme taken from a stomach in full digestion contains parapeptone, but scarcely any peptone. From this it may fairly be inferred that the peptone has been absorbed.

In the act of swallowing, no inconsiderable quantity of air is carried down into the stomach, entangled in the saliva, or in the food. This is returned in eructations. When the gas of eructation or that obtained directly from the stomach is examined, it is found to consist chiefly of nitrogen and carbonic acid, the oxygen of the atmospheric air having been largely absorbed. In most cases the carbonic acid is derived by simple diffusion from the blood, or from the tissues of the stomach, which similarly take up the oxygen. In many cases of flatulency, however, it may arise from a fermentative decomposition of the sugar which has been taken as such in food, or which has been produced from the starch.

In the latter case, however, hydrogen ought also to make its appearance; thus $C_6H_{12}O_6 = 2 C_3H_5O_2$ (lactic acid) $= C_4H_9O_2$ (butyric acid) $+ 2 CO_2 + H_2$, whereas hydrogen has only been found in the small intestine. In the dog, Planer¹ found in the stomach after a meat diet a small amount of gas of the composition CO 25·20, N 68·68, O 6·12, after a meal of bread, CO² 32·91, N 66·30, O 79.

The enormous quantity of gas which is discharged through the mouth in cases of hysterical flatulency, even on a perfectly empty stomach, and

¹ *Wien. Sitzungsberichte*, XLII. p. 307.

which seems to consist largely of carbonic acid, presents difficulties in the way of explanation; it is possible that it may be simply diffused from the blood.

In the small intestine, the semi-digested acid food, or chyme, as it passes over the biliary orifice, causes gushes of bile, and at the same time, as we have seen (p. 216), the pancreatic juice, which flowed freely into the intestine at the taking of the meal, is secreted again with renewed vigour, when the gastric digestion is completed. These two alkaline fluids tend to neutralize the acidity of the chyme, but the contents of the duodenum do not become distinctly alkaline until some distance from the pylorus is reached. Even in the lower part of the ileum the chyme may be acid¹; possibly however in such cases it has been reacidified. The conversion of starch into sugar, which may have languished in the stomach, is resumed with great activity by the pancreatic juice, though portions of undigested starch may be found in the large intestine and even at times in the fæces.

We have seen that the pancreatic juice emulsifies fats, and also splits them into their respective fatty acids and glycerine, and that the bile is able to a certain extent to saponify the free fatty acids. It also appears that the slight emulsifying power of the bile is much increased by the presence of soaps; and as a matter of fact the bile and pancreatic juice do largely emulsify the contents of the small intestine, so that the greyish turbid chyme is changed into a creamy-looking fluid, which has been called chyle. It is advisable however to reserve this name for the contents of the lacteals. To what extent saponification does take place is not known. Undoubtedly soaps have to a small extent been found both in portal blood and in the thoracic duct after a meal; but there is no proof that any large quantity of fat is introduced in this form into the circulation; on the other hand, the presence of neutral fats, both in portal blood, and especially in the lacteals, is a conspicuous result of the digestion of fatty matters; and in all probability saponification in the intestine is a subsidiary and unimportant process.

Much dispute has arisen on the question, how far the presence either of the bile or of the pancreatic juice, or of both, in the intestine is necessary for the digestion and absorption of fatty food. That the pancreatic juice does produce in the intestine such a change as favours the transference of neutral fats from the intestine into the lacteals is shewn by an observation, first made by Bernard. If a rabbit be killed a few hours after taking a meal rich in fat, and the abdomen opened, the lacteals running in the mesentery attached to the twelve inches or so of duodenum which in this animal intervene between the pylorus and the opening of the pancreatic duct, will hardly be visible to the naked eye on account of their transparency, whereas below the orifice of the duct they will be most conspicuous, on account of the fat which they contain. Above the pancreatic duct

¹ Losnitzer, Henle and Meissner's *Bericht*, 1864, p. 250.

the contents of the intestine are subject to the action of the bile, yet very little absorption of fat takes place; below the duct, the bile is aided by the pancreatic juice, and absorption of fat at once begins. Again, in disease of the pancreas, much fatty food frequently passes through the intestine undigested. On the other hand, in cases where all the pancreatic ducts have been ligatured, and there has been no reason to think that pancreatic juice to any amount has entered the intestine, fat may be present in the lacteals. In such cases the subsidiary pancreatic structures existing in the duodenal walls cannot be seriously supposed to have any effect, and in consequence the digestion of the fat must be referred to the bile. That the bile is of use in the digestion of fat is shewn by the prevalence of fatty stools in cases of obstruction of the bile-ducts, and though the operation of ligaturing the bile-ducts, and leading all the bile externally through a biliary fistula, is open to objection, since it so exhausts the animal as indirectly to affect digestion, still the results of Bidder and Schmidt, in which the resorption of fat was distinctly lessened (the quantity of fat in the lacteals falling from 3·2 to ·02 p. c.) by the ligature and fistula, obviously point to the same conclusion. Thus while the view that the bile alone, or the view that the pancreatic juice alone, is the agent in the digestion of fat, is contradicted by facts, the conflicting experiments are reconciled in the conclusion that both help towards the same end, the one agent possibly being more useful than the other in different animals; a conclusion which is in harmony with the properties of the juices, as seen when studied out of the body, and which is supported by the observation of Busch, in a case where the duodenum opened on the surface by a fistula in such a way that the lower part of the intestine could be kept free from the contents of the upper part containing the bile and pancreatic juice. Fats introduced into the lower part, where they could not be acted upon either by the bile or by the pancreatic juice, were but slightly digested. The succus entericus, or any other alkaline albuminous fluid, may have slight emulsifying power, but insufficient to meet the needs of the economy.

We have seen that bile, when added to a digesting mixture, precipitates parapeptone. The chyme as it issues from the pylorus contains undigested material and parapeptone with little or no peptone. We should expect this to be precipitated by the bile; and as a matter of fact we find the inner surface of the small intestine coated with a granular deposit, quite similar to the precipitate just mentioned. The object of this precipitation is at present unknown, unless it be to hinder the too rapid passage of the semi-digested liquids along the intestine. We have seen that bile, while it stops gastric digestion, favours rather than hinders the pancreatic digestion of proteids. As a matter of fact, since the contents of the stomach as they issue from the pylorus consist very largely of undigested proteids, these must be digested by the pancreatic juice, with or without the assistance of the succus entericus, since the pepsin of the

gastric juice is either precipitated by the bile, or rendered inert by the increasing alkalinity of the intestinal contents. To what stage the pancreatic digestion is carried, whether peptone is chiefly formed, and when formed at once absorbed, or to what extent the pancreatic juice in the body, as out of the body, carries on its work in the more destructive form, whereby the proteid material subjected to it is broken down largely into leucin and tyrosin, is at present not exactly known. Leucin and tyrosin are found in the intestinal contents, and are therefore formed during normal digestion, but whether a large quantity or a small quantity of the proteid material of food is thus hurried into a crystalline form cannot be definitely stated. Possibly where large quantities of proteids are taken at a meal, the excess is at once got rid of by this form of so-called 'luxus consumption;' and possibly also, in the intestine as in the laboratory, this pancreatic digestion of proteids in excess is accompanied by a considerable development of bacteria and other organized bodies, which create trouble by inducing fermentative changes in the accompanying saccharine constituents of the chyme.

That fermentative changes do occur in the small intestine is indicated by the fact that the gas present there does contain free hydrogen. Planer¹ found the gas from the small intestine of a dog fed on a meat diet to consist of CO² 40.1, H 13.86, N 45.52, with only a trace of oxygen. In a dog fed on vegetable diet the composition of the gas was CO² 47.34, H 48.69, N 3.97. Chyme after removal from the intestine continues at the temperature of the body to produce carbonic acid and hydrogen in equal volumes. As was stated above (p. 239), during butyric acid fermentation from sugar, carbonic acid and hydrogen are involved in equal volumes. These facts suggest the way in which the carbo-hydrate constituents of food may become converted into fat, for by this butyric acid fermentation the sugar is converted into a member of the fatty acid series; and it is at least within the bounds of possibility that, by fermentative changes of some sort or other, the lower members of the series may be raised to the higher. But did butyric acid fermentations occur largely in the intestine we should expect to find a large quantity of free hydrogen excreted by the bowel or lungs. As a matter of fact it is excreted in small quantities only or not at all. Hence, unless we suppose that the evolved hydrogen is rapidly brought back again into a state of combination, we must regard butyric acid fermentation as slight and unimportant. Indeed the quantity of gas on which Planer worked was small. It is probable however that a considerable quantity of sugar is converted by fermentative changes into lactic acid, since this acid is found in increasing quantities as the food descends the intestine.

Thus during its transit through the small intestine, by the action of the bile and pancreatic juice assisted possibly to some extent by the succus entericus, the proteids are largely dissolved and converted into peptone and other products, the starch is changed into sugar, the sugar possibly being in part further converted into lactic acid, and the fats are largely emulsified, and to some extent saponified.

¹ *Op. cit.*

These products, as they are formed, pass into either the lacteals or the portal blood-vessels, so that the contents of the small intestine, by the time they reach the ileo-cæcal valve, are largely but by no means wholly deprived of their nutritious constituents. As far as water is concerned, the secretion into the small intestine is about equal to the absorption from it, so that the intestinal contents at the end of the ileum, though much more broken up, are about as fluid as in the duodenum.

In the large intestine, the contents become once more distinctly acid. This, however, is not caused by any acid secretion from the mucous membrane; the reaction of the intestinal walls in the large as in the small intestine is alkaline. It must therefore arise from acid fermentations going on in the contents themselves; as indeed is shewn by the composition of the gases which make their appearance in this portion of the alimentary canal. In carnivora the contents of the cæcum are said to be alkaline¹, and naturally the amount of fermentation will depend largely on the nature of the food.

Ruge² found the gas of the large intestine, collected per anum, to have the following composition:

	Mixed diet.	Leguminous diet.	Meat diet.
CO ²	40·54	21·05	8·45
N.	17·50	18·96	64·41
CH ₄	19·77	55·94	26·45
H.	22·22	4·03	·69
SH,	a trace only.		

Of the particular changes which take place in the large intestine we have no definite knowledge; but it is exceedingly probable that in the voluminous cæcum of the herbivora, a large amount of digestion of a peculiar kind goes on. We know that in herbivora a considerable quantity of cellulose disappears in passing through the canal, and even in man some is probably digested. We are driven to suppose that this cellulose digestion is carried on in the large intestine, though we know nothing of the nature of the agency by which it is effected. The other digestive changes are probably of a fermentative kind.

Be this as it may, whether digestion, properly so called, is all but complete at the ileo-cæcal valve, or whether important changes still await the chyme in the large intestine, the chief characteristic of the work done in the colon is absorption. By the abstraction of all the soluble constituents, and especially by the withdrawal of water, the liquid chyme becomes as it approaches the rectum converted into the firm solid fæces, and the colour shifts from the bright orange, which the grey chyme gradually assumes after admixture with bile, into a darker and dirtier brown.

¹ Bernard, *Liquides de l'Organisme*.

² *Wien. Sitzungsberichte*, 1862, p. 729.

In the *fæces* there are found in the first place the indigestible and undigested constituents of the meal: shreds of elastic tissue, much cellulose from vegetable, and some connective tissue from animal food, fragments of disintegrated muscular fibre, fat cells, and not unfrequently undigested starch-corpuscles. The amount of each must of course vary very largely, according to the nature of the food, and the digestive powers, temporary or permanent, of the individual. In the second place, to these must be added substances, not introduced as food, but arising as part of, or as products of, the digestive secretions. The *fæces* contain a ferment similar to pepsin, and an amylolytic ferment similar to that of saliva or pancreatic juice. They also contain mucus in variable amount, sometimes albumin, cholesterolin, butyric and other fatty acids, lime and magnesia soaps, *excretin* (a non-nitrogenous crystalline body, containing sulphur, obtained by Marcet), and salts, especially those of magnesia. Cholalic acid (and dyslysin) are found in very small quantities only, thus indicating that the bile-salts have been in part at least destroyed (they may have been in part reabsorbed, see p. 223), the less stable taurocholic acid (of the dog) disappearing more readily than the glycocholic acid (of the cow). The fact that the *fæces* become 'clay-coloured' when the bile is cut off from the intestine shews that the bile-pigment is at least the mother of the *fæcal* pigment. We have already seen that during artificial pancreatic digestion, a distinctly *fæcal* odour due to the presence of indol is generated; and the fact that the presence of bacteria, or other similar organisms, is essential to the production of this body, does not preclude the possibility of it, with its derivatives, being the chief cause of the natural odour of *fæces*, for undoubtedly bacteria may exist throughout the whole length of the intestinal canal. At the same time it is quite possible, if not probable, that specific odoriferous substances may be secreted directly from the intestinal wall, especially from that of the large intestine.

SEC. 5. ABSORPTION OF THE PRODUCTS OF DIGESTION.

We have seen that absorption does, or at least may, take place from the stomach. We have also stated that a large absorption, especially of water, occurs along the whole large intestine.

Absorption from the large intestine after injection *per anum* or through a fistula has been observed not only in the case of soluble peptone and sugar, but also in that of starch, white of egg, and casein; but the exact changes undergone by the latter previous to absorption are unknown¹.

Nevertheless the largest and most important part of the digested material passes away from the canal, during the transit of food along the small intestine, partly into the lacteals, partly into the portal vessels.

¹ Bauer, *Zeitschft. f. Biol.* v. 536.

Digestion being, broadly speaking, the conversion of non-diffusible proteids and starch into highly diffusible peptone and sugar, and the emulsifying, or division into minute particles, of various fats, it is natural to suppose that the diffusible peptone and sugar pass by osmosis into the blood-vessels, and that the emulsified fats pass into the lacteals. That the great mass of the fat which enters the body from the intestine does pass through the lacteals, there can be no doubt; and there can be but little doubt that a considerable quantity of peptone and sugar does pass into the portal blood. But we are unable to say at present how far the fat in its difficult passage into the lacteal is accompanied by soluble peptone and sugar, and by less diffusible forms of proteids arising as subsidiary products of proteolytic digestion.

✓ **Characters of Chyle.** In a fasting animal the contents of the thoracic duct are clear and transparent; shortly after a meal they become milky and opaque, the change being entirely due to a difference in the quantity of the fluid brought to the duct by the lacteals, that fluid also being, as seen by inspection of the mesentery, transparent during fasting, and becoming milky and opaque after a meal, especially after one containing much fat. The contents of the thoracic duct therefore after a meal may be taken as illustrative of the nature of the chyle present in the lacteals, though strictly speaking the chyle of the thoracic duct is mixed with lymph coming from the rest of the body. During fasting the contents of the lacteals agree in their general character with lymph obtained from other structures.

The contents of the thoracic duct may be obtained by laying bare the junction of the subclavian and jugular veins and introducing a cannula into the duct as it enters into the venous system at that point. The operation is not unattended with difficulties.

Chyle obtained from the thoracic duct, after a meal, is a white milky-looking fluid, which after its escape coagulates, forming a not very firm clot. The nature of the coagulation seems to be exactly the same as that of blood. On standing, the surface of the clot becomes pink, even though no blood be artificially mixed with the chyle during the operation; the colour is due to immature red corpuscles proper to the chyle. Examined microscopically, the chyle consists of fibrin, a large number of white corpuscles, a small number of developing red corpuscles, an abundance of oil-globules of various sizes but all small, and a quantity of finely granular material fatty in nature, the so-called 'molecular basis.' Each oil-globule is invested with an albuminous envelope; this may be dissolved by the aid of alkalis, whereupon the globules run together. The fibrin and white corpuscles are very scanty (and the red corpuscles entirely absent) in lymph or chyle taken from peripheral vessels; but they increase in quantity as the lymph passes through the lymphatic glands.

The composition of chyle varies considerably not only in different

animals but in the same animal at different times. The average percentage of solids may perhaps be put down as about 9, that of proteid material as about 4 or 5, and that of fat as about 3 or 4, the remainder being extractives and salts. The fats occur chiefly in the form of neutral salts, though some soaps or fatty acids are present.

The percentages of solid matters vary in the different analyses from 3 to 11, of proteids from 2 to 7, of fats from less than 1 to 4¹. The proteids consist chiefly of serum-albumin, with a globulin or alkali-albumin precipitable by acids, and a variable but small quantity of fibrin. Among the extractives have been found sugar, urea, and leucin; cholesterin is also frequently present in considerable quantity. Since these extractives are found in lymph as well as chyle they cannot be regarded as derived exclusively from the intestinal contents. The amount of peptone is very small indeed. The gas which can be extracted from chyle or lymph consists almost entirely of carbonic acid there being only a small quantity of nitrogen, and no satisfactory evidence of the presence of any free oxygen at all. Hammarsten² obtained from the 100 vols. of lymph of the dog about 1·5 (1·17)³ vols. nitrogen, and about 53 (40·36) vols. carbonic acid. The ash is remarkable for the abundance of sodium chloride and the scantiness of phosphates. Iron is present in greater quantity than can be accounted for by the presence of red corpuscles.

The nature of the fat is supposed to vary with that of the food, but this has not been conclusively shewn.

The lymph taken from the duct during fasting differs chiefly from that taken after a meal, in the much smaller quantity of fat, the microscope shewing white corpuscles with very few oil-globules, and in the almost entire absence of the molecular basis. Lymph in fact is, broadly speaking, blood *minus* its red corpuscles, and chyle is lymph *plus* a very large quantity of minutely divided neutral fat.

It has been calculated that a quantity equal to that of the whole blood may pass through the thoracic duct in 24 hours, and of this it is supposed that about half comes from food through the lacteals and the remainder from the body at large; but these calculations are based on uncertain data.

Entrance of the Chyle into the Lacteals. The lacteal begins as a club-shaped (or bifurcate) lymphatic space lying in the centre of the villus, and connected with the smaller lymphatic spaces of the adenoid tissue around it; it opens below into the submucous lymphatic plexus from which the lacteal vessels spring. The adenoid tissue of the surrounding crypts of Lieberkühn is by its lymphatic spaces connected with the same lymphatic plexus. That the finely-divided fat does pass from the intestine, through the epithelial enve-

¹ Cf. Hensen, *Pflüger's Archiv*, x. (1875) p. 94.

² Ludwig's *Arbeiten*, 1871, p. 121.

³ The larger figures are the measurements obtained at 0° C. and a pressure of 760 mm. mercury, the smaller figures in brackets the measurements according to the prevalent German method at 0° C. and 1 metre of mercury pressure.

lope of the villus, into the adenoid tissue, and so into the lacteal chamber, is certain, but much discussion has arisen as to the exact mechanism of the transit. The passage is probably assisted by the movements of the intestine, though even in the contractions of strong peristaltic movements the pressure within the intestine is never very great. Of more obvious use is the contraction of the villus itself. The longitudinal muscular fibre-cells, in contracting, pull down the villus on itself; the contents of the lacteal chamber are thus forced into the underlying lymphatic plexus. When the fibre-cells relax, the empty lacteal chamber is expanded; the chyle cannot flow back from the lymphatic channels, by reason of the valves present in them, and in consequence the lacteal chamber is filled from the substance of the villus, and thus the entrance into the villus of material from the intestine is facilitated. The villus in fact acts as a kind of muscular suction-pump.

After a meal the epithelium cells of the villus are found crowded with fat. Since the striation of the hyaline border of the cells is not due to pores, as was once thought, the particles must have entered into the cells very much as foreign particles enter the body of an amœba. The epithelium may in fact be said to eat the fat. Since the (frequently) branched and protoplasmic base of the cell is in intimate connection with the spaces of the adenoid tissue of the villus, the fat could more readily pass from the cell in this direction than from the intestine into the cell. There would thus be a stream of fatty particles through the cell from without inwards, a stream in the causation of which the cell took an active part. In fact, under this view, absorption by the cell might be regarded as a sort of inverted secretion, the cell taking much material from the chyme and secreting it, with little or no change, into the villus. The observations of Watney¹ have led him to believe that the fat passes not through but between the epithelium-cells, being taken up by the inter-epithelial processes of the peculiar epithelioid cells described by him, the epithelium-cells themselves therefore having no active share in absorption. It is difficult on this view however to explain the almost unanimous opinion of previous observers, that the fat may be seen in the substance of the cell itself, though Watney argues that particles of fat adhering to the outside of the cell have been erroneously supposed to be really within the cells.

Brücke² observed that after a meal of milk, the contents of the villus after death were loaded with a granular deposit of proteid nature, and of an acid reaction. He infers from this that together with the fat there passes into the villus a quantity of the proteid material of food in the form of alkali-albumin, precipitable by weak acids; and argues from this and other facts that a considerable quantity of the proteids of food thus obtains entrance into the blood without suffering the change into peptone.

Movements of the Chyle. Having reached the lymphatic channels the onward progress of the chyle is determined by a variety of circumstances. Putting aside the pumping action of the villi, the same events which cause the movement of the lymph generally, also

¹ *Proc. Roy. Soc.* xxii. (1874) 293, xxiv. (1876) 241.

² *Wien. Sitzungsberichte*, xxxvii. lxx.

further the flow of the chyle; and these are briefly as follows. In the first place, the widespread presence of valves in the lymphatic vessels causes every pressure exerted on the tissues in which they lie, to assist in the propulsion forward of the lymph. Hence all muscular movements increase the flow. If a cannula be inserted in one of the larger lymphatic trunks of the limb of a dog, the discharge of lymph from the cannula will be more distinctly increased by movements, even passive movements, of the limb than by anything else. In addition to the valves along the course of the vessels, the embouchement of the thoracic duct into the venous system is guarded by a valve, so that every escape of lymph or chyle from the duct into the veins becomes itself a help to the flow. In the second place, considering the whole lymphatic system as a set of branching tubes passing from the extra-vascular regions just outside the small arteries, veins and capillaries, to the large venous trunks, it is obvious that the mean pressure of the blood in the subclavian vein, at its junction with the jugular, must be considerably less than that of the lymph in the lymphatic spaces around the small blood-vessels, even if we suppose the pressure in the tissues outside the small blood-vessels to be distinctly less than that of the blood within the same vessels. In other words, there is a distinct fall of pressure in passing from the beginning to the end of the lymphatics; this of course would alone cause a continuous flow. Further, this flow caused by the lowness of the mean venous pressure at the subclavian will be assisted at every respiratory movement, since at every inspiration the pressure in the venous trunks becomes negative, and thus lymph will be sucked in from the thoracic duct, while the increase of pressure in the great veins during expiration is warded off from the duct by the valve at its opening. In the third place, the flow may be increased by rhythmical contractions of the muscular walls of the lymphatics themselves; but this is doubtful, since it is not clear whether the rhythmic variations seen by Heller¹ in the mesentery of the guinea-pig were active or simply passive, *i.e.* caused by the rhythmic peristaltic action of the intestine, each contraction of the intestine filling the lymph-channels more fully. Lastly, it is quite open for us to suppose that just as osmosis may give rise to increased pressure on one side of a diffusion septum, so the diffusion of substances from the intestines into the lacteals, or from the tissues into the lymphatics, may be itself one of the causes of the flow of lymph. We have at least, under all circumstances, one or other of these causes at work promoting a continual flow from the lymphatic roots to the great veins. We have no very satisfactory evidence that the flow of lymph is in any way directly governed by the nervous system.

In frogs and some other animals the centripetal flow of lymph from the limbs is assisted by rhythmically pulsating muscular lymph-hearts.

¹ *Cbt. Med. Wiss.* 1869, p. 545.

The observations of Paschutin¹ and Emminghaus² failed to shew any direct connection between the nervous system and the lymph-flow. Section of the sciatic, leading to arterial dilation and consequent increased pressure in the capillaries and small veins, had very little effect, whereas ligation of the veins led to a very marked increase. Active movements of the limb, caused by stimulation of the sciatic, produced no greater flow than did passive movements. Goltz³ has recorded an interesting observation, bearing on the influence of the nervous system on absorption. Of two unwarized frogs, the brain and spinal cord of one are destroyed, but in the other are left intact. Both animals are suspended by the lower jaw; chloride of sodium solution (.75 per cent.) is poured into the dorsal lymphatic sacs of both; and in both the aorta is cut across. In the one where the nervous system is intact, absorption from the lymphatic sac takes place copiously, and the heart pumps out large quantities of fluid by the aorta. In the other absorption does not occur; the heart, though beating, remains empty, and the skin becomes dry. The result however shews rather the influence of the nervous system in maintaining the tonicity of the blood-vessels and keeping up the connection of the heart with the peripheral vessels, than any distinct connection between absorption proper and the nervous system. When the nervous system is destroyed, dilation of the splanchnic vascular area causes all the blood to remain stagnant in the portal vessels, so that little or none reaches the heart. So long as the nervous system is still intact this stagnation does not occur, and the blood reaches the heart; as the blood is pumped away its place is renewed by the lymph, supplied by the fluid in the sac, and thus the heart may be made for a long time to pump away the fluid poured into the sac. Still, though we cannot prove any direct connection between the nervous system and absorption, the phenomena of disease render such a connection at least probable.

Thus the digested contents of the intestine pass into the blood either directly by the portal system or indirectly by means of the lymphatics. It cannot be a matter of indifference which course is taken by the particular digestive products; for in the latter case, they pass into the general blood-current with only such changes as they may undergo in the lymphatic system, while in the former they are subjected to the powerful influences of the liver before they find their way to the right side of the heart. What those influences are we shall study in a future chapter.

As was stated above, the great mass of the digested (*i.e.* emulsified) fat passes into the lacteals. Since however the portal blood during digestion contains more fat than the general venous blood, some of the fats must pass through into the portal capillaries. The portal blood, moreover, during digestion contains a small but appreciable quantity of soaps. Neither in the portal blood, nor in the chyle, nor in the general blood during digestion, is there any appreciable quantity of peptone. Of course the quantity of peptone passing into the portal blood at any one moment might be small, and yet

¹ Ludwig's *Arbeiten*, 1872, p. 197.

² *Ibid.* 1873, p. 51.

³ Pfüger's *Archiv*, v. (1872) p. 53.

a considerable quantity might so pass during the hours of digestion. That which did pass, moreover, might be immediately converted back again into another form of proteid; and Plósz and Gyergyai¹ have shewn that peptone injected carefully into a vein disappears from the blood, though little or even none passes out by the kidney. Hence the failure to find peptone in the blood is an insufficient argument that peptone is not formed during natural digestion. Did the peptone pass with the fats into the chyle, one would expect to find it in the thoracic duct, though here also a reconversion into native proteid might befall it in its transit through the lacteals. It must therefore be left uncertain what becomes of the peptone formed during digestion, and which way it travels. We know, however, that artificially-formed peptone is available for nutrition; thus Plósz² and Plósz and Gyergyai³ found that dogs fed on peptone and non-nitrogenous food actually put on flesh and gained weight. The chyle contains no large amount of sugar, and though sugar may undoubtedly be found after amylaceous meals in the portal blood, we are not at present in a position to say whether sugar is absorbed chiefly by the portal system or chiefly by the lacteals, still less can we decide whether all or even a large part of the carbo-hydrates taken as food enter the blood as sugar, or whether the fermentative changes spoken of above are carried on in at all a large scale.

When a solution of sugar is injected into an empty isolated loop of intestine a large quantity disappears, without the contents of the loop becoming acid⁴. In such a case it may fairly be inferred that the sugar is directly absorbed without undergoing any change. And where sugar is introduced in large quantities into the alimentary canal, the percentage of sugar in the blood may be temporarily increased; to such an extent indeed that sugar may appear in the urine⁵. But neither of these facts prove that the sugar of an ordinary meal, passing as it does along the intestine with the other portions of the food, and products of digestion, and appearing as it does in most cases in comparatively small quantities at a time from the more or less gradual conversion of the starch of the meal, is similarly absorbed unchanged; while in order that the marked acidity of the contents of the lower intestine should be kept up, a considerable quantity of sugar must suffer lactic acid fermentation, if the acidity be due as stated to lactic acid.

Absorption by diffusion. It is evident, from the discussion just concluded, that simple diffusion is far from explaining the whole transit of the digested food from the intestine into the blood. Part of the digestive products, viz. the fats, are not diffusible, and with regard to the diffusible peptone and sugar, it is uncertain whether they pass by simple diffusion through the membrane formed by the epithelium of the alimentary mucous membrane, the thin capillary walls and the adenoid tissue existing between the epithelium and the capil-

¹ Pflüger's *Archiv*, x. (1875) 536.

² *Ibid.* ix. (1874) 325.

³ *Op. cit.*

⁴ Funke, *Lehrb.* 6th Aufl. i. p. 235.

⁵ C. Schmidt und v. Becker quoted in Funke, *Op. cit.* p. 236.

lary, or whether they accompany the fats and enter the lacteals by a way which, whatever it be, is not one of simple diffusion. Moreover, the fact that unchanged fat makes its way into the portal blood, though we are ignorant of the mechanism by which this is effected, shews that the entrance of material directly into the blood, as distinguished from its passage into the lacteals, is not simply a matter of diffusion. Nevertheless, it must not be supposed that the great and general property of diffusion does not make itself felt in the process of absorption, however much it may, in the case of various substances, be subordinated and held in check by more potent influences. Thus the passage of water from the alimentary cavity into the blood, or from the blood into the alimentary cavity, and the behaviour of various inorganic salts, when taken as food or medicine, illustrate very clearly the influence of osmosis. When the intestine contains a large quantity of watery matter, the surplus water passes by diffusion into the blood, just as it passes through the membrane of a dialyser with blood, or serous fluid on the one side, and water on the other. When an albuminous fluid of the specific gravity of blood-serum is exposed in a dialyser to water, about 200 parts of water pass through the membrane of the dialyser from the water into the albuminous fluid for every one part of albumin which passes from the fluid into the water. Moreover, in the living body, the blood in the mesenteric capillary, thus diluted by diffusion from the intestinal contents, is continually being replaced by fresh blood concentrated by its passage through the skin, lung, or kidney. By the help of the circulation an almost unlimited quantity of water can be absorbed from the alimentary canal.

It is a matter of common experience that such inorganic and organic salts as are readily diffusible, pass with great rapidity into the blood (and thus into the urine) when taken by the mouth; and the rapidity with which they are absorbed is in large measure proportionate to their diffusibility. Of course, coincident with this passage of the salt from the intestine into the blood, there is a proportionate current of water in the contrary direction from the blood into the intestine; but this, though opposed to, is, under ordinary circumstances, too small to diminish to any serious extent the passage of water from the intestine into the blood, of which we spoke just now, as caused by the osmotic influence of the albuminous constituents of the blood. But, under certain circumstances, the former may overcome the latter. Thus, when a concentrated solution of a highly diffusible salt, such as magnesium sulphate, is introduced into the alimentary canal, the flow of water from the blood into the intestine accompanying the osmotic transit of the salt from the intestine into the blood, is so great as largely to exceed the current in the contrary direction; and the intestine becomes filled with water at the expense of the blood. This is probably the cause of the purgative action of large doses of many saline matters. And even the purgative action of more dilute solutions may be explained in the same way, since in

the case of some salts at least the transit of water as compared to the transit of the salt is relatively more rapid with very dilute solutions than with more concentrated solutions. Salts such as these, which, when introduced into the intestine, produce diarrhœa, bring about a contrary condition when injected directly into the blood; and magnesium sulphate, with its higher endosmotic equivalent, is more purgative in its action than sodium chloride with its lower equivalent.

Our knowledge of the physiology of digestion is the accumulated gain of many labours, some dating back from very old times. To Reaumur, Spallanzani, Tiedemann and Gmelin, Eberle (who first obtained artificial digestion with gastric mucus and an acid), Prout, Schwann (who first introduced the idea of *pepsin*¹, though Wasmann first obtained it in a comparatively pure state), Berzelius and other chemists, we owe much. The observations of Dr Beaumont², carried on by means of the accidental gastric fistula of Alexis St Martin, not only added largely to our positive knowledge, but were also of great indirect use as indicating a method of investigation which has since proved so fruitful. The labours of Bidder and Schmidt³ and Frerichs⁴ were of great value. The publication of Bernard's work on pancreatic juice⁵ marked a distinct step in advance; but of far greater importance was the same illustrious physiologist's discovery of the vaso-motor action of the sympathetic, see p. 179, followed up as that was by Ludwig's demonstration⁶ of the secretory activity of the chorda tympani, and enlarged, as this has been in turn, as well by the labours of Ludwig and his school, as by those of Bernard, Eckhard, Wittich, Heidenhain and others. To the importance of Heidenhain's later observations we have called attention in the text. The proofs offered by Corvisart⁷, and amplified by Kühne⁸, of the proteolytic action of the pancreatic juice opened out a line of inquiry of great importance, which is as yet far from being exhausted.

¹ Müller's *Archiv*, 1836, p. 90.

² *Exps. and Obs. on the Gastric Juice and Phys. of Digestion*. Boston, U. S. 1834.

³ *Die Verdauungssäfte*, &c. 1852.

⁴ Art. 'Verdauung,' Wagner's *Handwörterbuch*, 1846.

⁵ *Mém. sur l. Pancreas*, 1856.

⁶ *Zt. f. Rat. Med.* N. F. i. p. 255, 1851.

⁷ *Sur une Fonction peu connue du Pancreas*, 1857.

⁸ Virchow's *Archiv*, xxxix. (1867), p. 130.

CHAPTER II.

THE TISSUES AND MECHANISMS OF RESPIRATION.

We have already seen (Introduction, p. 3) that one particular item of the body's income, viz. oxygen, is peculiarly associated with one particular item of the body's waste, viz. carbonic acid, the means which are applied for the introduction of the former being also used for the getting rid of the latter. Both are gases, and in consequence the ingress of the one as well as the egress of the other is far more dependent on the simple physical process of diffusion than any on active vital processes carried on by means of tissues. Oxygen passes from the air into the blood mainly by diffusion, and mainly by diffusion also from the blood into the tissues; in the same way carbonic acid passes mainly by diffusion from the tissues into the blood, and from the blood into the air. Whereas, as we have seen, in the secretion of the digestive juices the epithelium-cell plays an all-important part, in respiration the entrance of oxygen from the lungs into the blood, and from the blood into the tissue, and the passage of carbonic acid in the contrary direction, are affected, if at all, in a wholly subordinate manner, by the behaviour of the pulmonary, or of the capillary epithelium. What we have to deal with in respiration then is not so much the vital activities of any particular tissue, as the various mechanisms by which a rapid interchange between the air and the blood is effected, the means by which the blood is enabled to carry oxygen and carbonic acid to and from the tissues, and the manner in which the several tissues take oxygen from and give carbonic acid up to the blood. We have reasons for thinking that oxygen can be taken into the blood, not only from the lungs, but also from the skin, and, as we have seen, occasionally from the alimentary canal also; and carbonic acid certainly passes away from the skin, and through the various secretions, as well as by the lungs. Still the lungs are so eminently the channel of the interchange of gases between the body and the air, that in dealing at the present with respiration, we shall confine ourselves entirely to pulmonary respiration, leaving the consideration of the subsidiary respiratory processes till we come to study the secretions of which they respectively form part.

SEC. 1. THE MECHANICS OF PULMONARY RESPIRATION.

The lungs are placed, in a semi-distended state, in the air-tight thorax, the cavity of which they, together with the heart, great blood-vessels and other organs, completely fill. By the contraction of certain muscles the cavity of the thorax is enlarged; in consequence the pressure of the air within the lungs becomes less than that of the air outside the body, and this difference of pressure causes a rush of air through the trachea into the lungs until an equilibrium of pressure is established between the air inside and that outside the lungs. This constitutes inspiration. Upon the relaxation of the inspiratory muscles (the muscles whose contraction has brought about the thoracic expansion), the elasticity of the chest-walls and lungs, aided by the contraction of certain muscles and other circumstances, causes the chest to return to its original size or even to become smaller; in consequence of this the pressure within the lungs now becomes greater than that outside, and thus air rushes out of the trachea until equilibrium is once more established. This constitutes expiration; the inspiratory and expiratory act together forming a respiration. The fresh air introduced into the upper part of the pulmonary passages by the inspiratory movement contains more oxygen and less carbonic acid than the old air previously present in the lungs. By diffusion the new or *tidal* air, as it is frequently called, gives up its oxygen to, and takes carbonic acid from the old or *stationary* air, and thus when it leaves the chest in expiration has been the means of both introducing oxygen into the chest and of removing carbonic acid from it. In this way, by the ebb and flow of the tidal air, and by diffusion between it and the stationary air, the air in the lungs is being constantly renewed through the alternate expansion and contraction of the chest.

In ordinary respiration, the expansion of the chest never reaches its maximum; by more forcible muscular contraction, by what is called laboured inspiration, an additional thoracic expansion can be brought about, leading to the inrush of a certain additional quantity of air before equilibrium is established. This additional quantity is often spoken of as *complemental* air. In the same way in ordinary respiration, the contraction of the chest never reaches its maximum. By calling into use additional muscles, by a laboured expiration, an additional quantity of air, the so-called *reserve* or *supplemental* air, may be driven out. But even after the most forcible expiration, a considerable quantity of air, the *residual* air, still remains in the lungs. The natural condition of the lungs in the chest is in fact one of partial distension. The elastic pulmonary tissue is always to a certain extent on the stretch; it is always, so to speak, striving to pull asunder the pulmonary from the parietal pleura; but this it cannot do, because the air can have no access to the pleural cavity.

When however the chest ceases to be air-tight, when by a puncture of the chest-wall or diaphragm, air is introduced into the pleural chamber, the elasticity of the lungs pulls the pulmonary away from the parietal pleura, and the lungs collapse, driving out by the windpipe a considerable quantity of the residual air. Even then, however, the lungs are not completely emptied, some air still remaining in the air-cells and passages. It need hardly be added that when the pleura is punctured, and air can gain free admittance from the exterior into the pleural chamber, the effect of the respiratory movements is simply to drive air in and out of that chamber, instead of in and out of the lung. There is in consequence no renewal of the air within the lungs under those circumstances.

In man the pressure exerted by the elasticity of the lungs alone amounts to about 5 mm. of mercury. This is estimated by tying a manometer into the windpipe of a dead subject and observing the rise of mercury which takes place when the chest-walls are punctured. If the chest be forcibly distended beforehand, a much larger rise of the mercury, amounting to 30 mm. in the case of a distension corresponding to a very forcible inspiration, is observed. In the living body this mechanical elastic force of the lungs is assisted by the contraction of the plain muscular fibres of the bronchi; the pressure however which can be exerted by these probably does not exceed 1 or 2 mm.

When a manometer is introduced into a lateral opening of the windpipe of an animal, the mercury will fall, indicating a negative pressure as it is called, during inspiration, and rise, indicating a positive pressure, during expiration, the former or negative pressure amounting to about 3 mm., and the latter or positive pressure to 2 mm. of mercury. When a manometer is fitted with air-tight closure into the mouth, or better, in order to avoid the suction-action of the mouth, into one nostril, the other nostril and the mouth being closed, and efforts of inspiration and expiration are made, the mercury falls or undergoes negative pressure with inspiration, and rises, or undergoes positive pressure during expiration. Donders found in this way that the negative pressure of a strong inspiratory effort varied from 30 to 74 mm., while the positive pressure of a strong expiration varied from 62 to 100 mm.

The total amount of air which can be given out by the most forcible expiration following upon a most forcible inspiration, that is, the sum of the complemental, tidal and reserve airs, was called by Hutchinson "the vital capacity;" "extreme differential capacity" is a better phrase. It may be measured by a modification of a gas-meter called a *spirometer*. The medium vital capacity may be put down at 3—4000 cc. (200 to 250 cubic inches).

Independent of other causes of variation, Hutchinson found the vital capacity to be decidedly dependent on stature, the taller persons having the greater capacity.

Of the whole measure of vital capacity, about 500 cc. (30 c. inch) may be put down as the average amount of tidal air, the remainder being nearly equally divided between the complemental and reserve

airs. The quantity left in the lungs after the deepest expiration amounts to about 1400—2000 cc.

Since the respiratory movements are so easily affected by various circumstances, the simple fact of attention being directed to the breathing being sufficient to cause modifications, both of the rate and depth of the respiration, it becomes very difficult to fix the volume of an average breath. Thus various authors have given figures varying from 53 cc. to 792 cc. The statement made above is that given by Vierordt as the mean of observations varying from 177 to 699 cc.

The Rhythm of Respiration. If the movements of the column of tidal air, or the movements of expansion and contraction, or the fall and rise of the diaphragm, be registered, some such curve as that represented in Fig. 38 is obtained.

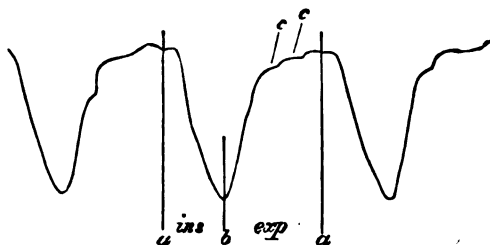

FIG. 38. TRACING OF THORACIC RESPIRATORY MOVEMENTS OBTAINED BY MEANS OF MAREY'S PNEUMOGRAPH. (To be read from left to right.)

A whole respiratory phase is comprised between *a* and *a*; inspiration, during which the lever descends, extending from *a* to *b*, and expiration from *b* to *a*. The undulations at *c* are caused by the heart's beat.

The movements of the column of air may be recorded by introducing a T piece into the trachea, one cross piece being left open or connected with a piece of indiarubber tubing open at the end, and the other connected with a Marey's tambour or with a receiver which in turn is connected with a tambour, Fig. 39. The movements of the column of air in the trachea are transmitted to the tambour, the consequent expansions and contractions of which are transmitted by means of a lever resting on it to the recording drum. The movements of the chest-walls may be recorded by means of the recording stethometer of Burdon Sanderson¹. This consists of a rectangular framework constructed of two rigid parallel bars joined at right angles to a cross piece. The free ends of the bars, the distance between which can be regulated at pleasure, are armed, the one with a tambour the other simply with an ivory button. The tambour also bears on the metal plate of its membrane (Fig. 23 *m'*, p. 117) a small ivory button (in place of the lever shewn in Fig. 23). When it is desired to record the changes occurring in any diameter of the chest, *e. g.* an antero-posterior diameter from a point in the back to a point in the sternum, the instrument is made to encircle the chest somewhat after the fashion of a pair of callipers, the ivory button at one free end being placed on the spine of a verte-

¹ *Hdb. Phys. Lab.* p. 291.

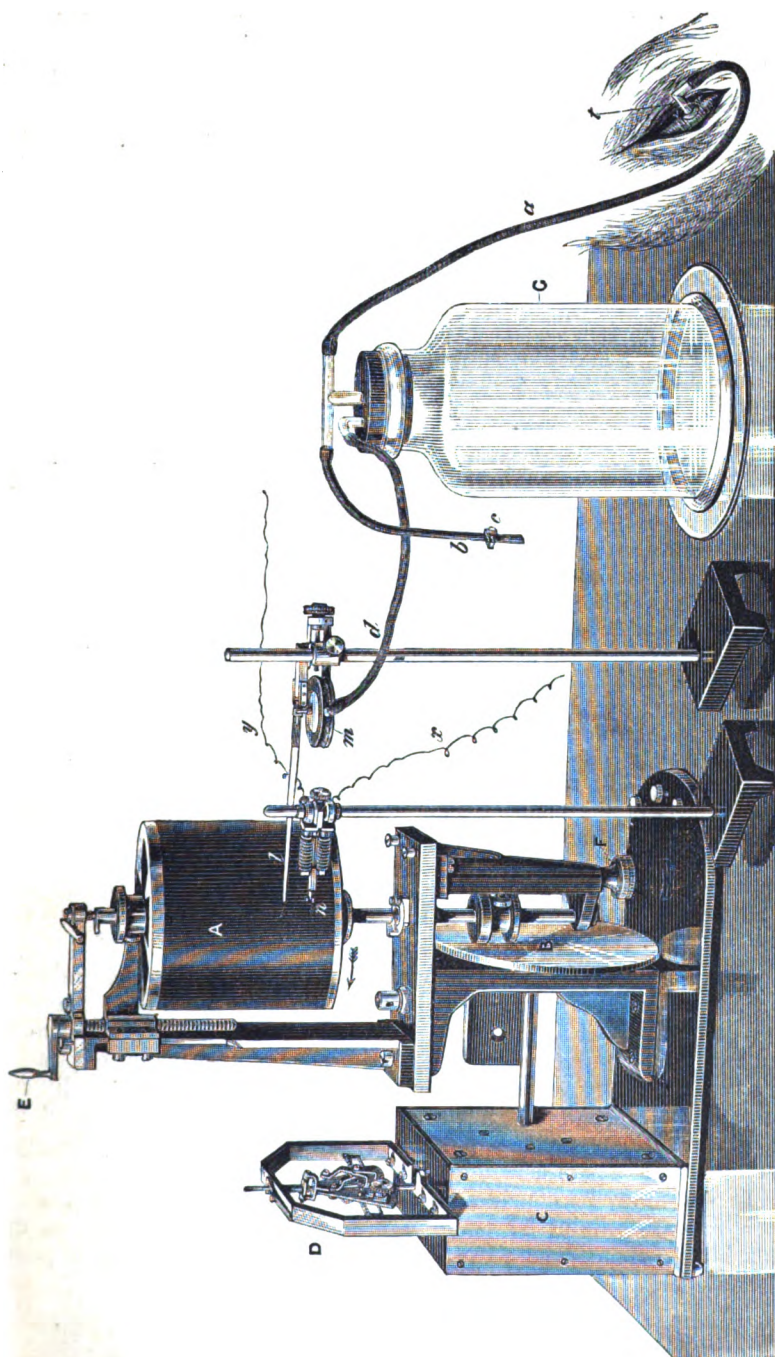

FIG. 39.

FIG. 39. APPARATUS FOR TAKING TRACINGS OF THE MOVEMENTS OF THE COLUMN OF AIR IN RESPIRATION.

The recording apparatus shown is the ordinary cylinder recording apparatus. The cylinder A covered with smoked paper is by means of the friction-plate B put into revolution by the spring clock-work in C regulated by Foucault's regulator D. By means of the screw E, the cylinder can be raised or lowered, and by means of the screw F its speed may be increased or diminished.

The tracheotomy tube *t* fixed in the trachea of an animal is connected by india-rubber tubing *a* with a glass T piece inserted into the large jar G. From the other end of the T piece proceeds a second piece of tubing *b*, the end of which can be either closed or partially obstructed at pleasure by means of the screw clamp *c*. From the jar proceeds a third piece of tubing *d*, connected with a Marey's tambour *m* (see Fig. 23, p. 117), the lever of which *l* writes on the recording surface. When the tube *b* is open the animal breathes freely through this, and the movements in the air of G and consequently in the tambour are slight. On closing the clamp *c*, the animal breathes only the air contained in the jar, and the movements of the lever of the tambour become consequently much more marked.

Below the lever is seen a small time-marker *n* connected with an electromagnet, the current through which coming from a battery by the wires *x* and *y* is made and broken by a clock-work or metronome.

bra behind and the tambour at the other on the sternum in front in the line of the diameter which is being studied. The distance between the free ends of the instrument being carefully adjusted so that the button of the tambour presses slightly on the sternum, any variations in the length of the diameter in question will, since the framework of the tambour is immobile, give rise to variations of pressure within the tambour. These variations of the "receiving" tambour as it is called are conveyed by a flexible tube containing air to a second or "recording" tambour similar to that shown in Fig. 23, the lever of which records the variations on a travelling surface. For the purpose of measuring the extent of the movements the instrument must be experimentally graduated. In Marey's pneumograph, a long elastic chamber is used as a pectoral girdle. When the chest expands, the girdle is elongated, and the air within it rarefied, and the lever of the tambour connected with it depressed; and conversely, when the chest contracts, the lever is elevated. The pneumograph of Fick is somewhat similar. The movements of the diaphragm may be registered by means of a needle, which is thrust through the sternum so as to rest on the diaphragm, the head of the needle being connected with a lever¹.

It is seen that in Fig. 38 inspiration begins somewhat suddenly and advances rapidly, that expiration succeeds inspiration immediately, advancing at first rapidly, but afterwards more and more slowly, and that such pauses as are seen occur between the end of expiration and the beginning of inspiration. In normal breathing, hardly any pause is observed between the extreme end of expiration and the beginning of inspiration, but in cases where the respiration becomes infrequent, pauses of considerable length may be observed.

In what may be considered as normal breathing, the respiratory act is repeated about 17 times a minute; and the duration of the inspiration as compared with that of the expiration and such pause as exists is about as ten to twelve.

¹ See *Hdb. Physiol. Laborat.* p. 295.

The rate of the respiratory rhythm varies very largely, and in this as in the volume it is very difficult to fix a satisfactory average. While Hutchinson places it at 20 a minute, Vierordt puts it at 11·9, and Funke at 13·5. The frequency is greater in children than in adults, but rises again somewhat after 30 years of age. Quetelet gives the rate of respiration of newborn infants at 44; from 1 to 5 years, 26, from 25 to 30, 16, from 30 to 50, 18·1 per minute. The rate is influenced by the position of the body, being quicker in standing than in lying, and in lying than in sitting. Muscular exertion and emotional conditions affect it deeply. In fact, almost every event which occurs in the body may influence it. We shall have to consider in detail hereafter the manner in which this influence is brought to bear.

When the ordinary respiratory movements prove insufficient to effect the necessary changes in the blood, their rhythm and character become changed. Normal respiration gives place to laboured respiration, and this in turn to *dyspnœa*, which, unless some restorative event occurs, terminates in *asphyxia*. These abnormal conditions we shall study more fully hereafter.

The Respiratory Movements.

When the movements of the chest during normal breathing are watched, it is seen that during respiration an enlargement takes place in the antero-posterior diameter, the sternum being thrown forwards, and at the same time moving upward. The lateral width of the chest is also increased. The vertical increase of the cavity is not so obvious from the outside, though when the movements of the diaphragm are watched by means of an inserted needle, the upper surface of that organ is seen to descend at each inspiration, the anterior walls of the abdomen bulging out at the same time. In the female human subject, the movement of the upper part of the chest is very conspicuous, the breast rising and falling with every respiration; in the male, however, the movements are almost entirely confined to the lower part of the chest. In laboured respiration all parts of the chest are alternately expanded and contracted, the breast rising and falling as well in the male as in the female. We have now to consider these several movements in greater detail, and to study the means by which they are carried out.

Inspiration. There are two chief means by which the chest is enlarged in normal inspiration, viz. the descent of the diaphragm and the elevation of the ribs. The former causes that movement in the lower part of the chest and abdomen so characteristic of male breathing, which is called diaphragmatic; the latter causes the movement of the upper chest characteristic of female breathing, which is called costal. These two main factors are assisted by less important and subsidiary events.

The descent of the diaphragm is effected by means of the contraction of its muscular fibres. When at rest the diaphragm

presents a convex surface to the thorax; when contracted it becomes much flatter, and in consequence the level of the chest-floor is lowered, the vertical diameter of the chest being proportionately enlarged. In descending, the diaphragm presses on the abdominal viscera, and so causes a projection of the flaccid abdominal walls. From its attachments to the sternum and the false ribs, the diaphragm, while contracting, naturally tends to pull the sternum and the upper false ribs downwards and inwards, and the lower false ribs upwards and inwards, towards the lumbar spine. In normal breathing, this tendency produces little effect, being counteracted by the accompanying general costal elevation, and by certain special muscles to be mentioned presently. In forced inspiration however, and especially where there is any obstruction to the entrance of air in the lungs, the lower ribs may be so much drawn in by the contraction of the diaphragm, that the girth of the trunk at this point is obviously diminished.

The elevation of the ribs is a much more complex matter than the descent of the diaphragm. If we examine any one rib, such as the fifth, and observe that while it moves freely on its vertebral articulation, it descends when in the position of rest in an oblique direction from the spine to the sternum, it is obvious that when the rib is raised, its sternal attachment must not only be carried upward, but also thrown forwards. The rib may in fact be regarded as a radius, moving on the vertebral articulation as a centre, and causing the sternal attachment to describe an arc of a circle in the vertical plane of the body; as the rib is carried upwards from an oblique to a more horizontal position, the sternal attachment must of necessity be carried farther away in front of the spine. Since all the ribs have a downward slanting direction, they must all tend, when raised towards the horizontal position, to thrust the sternum forward, some more than others according to their slope and length. The elasticity of the sternum and costal cartilages, together with the articulation of the sternum to the clavicle above, permit the front surface of the chest to be thus thrust forwards as well as upwards, when the ribs are raised. By this action, the antero-posterior diameter of the chest is enlarged.

- According to A. Ransome, the forward movement of the upper ribs is so great that it can only be accounted for by a concomitant straightening of the ribs.

Since the ribs form arches which increase in their sweep as one proceeds from the first downwards as far at least as the seventh, it is evident that when a lower rib such as the fifth is elevated so as to occupy or to approach towards the position of the one above it, the chest at that level will become wider from side to side, in proportion as the fifth arch is wider than the fourth. Thus the elevation of the rib increases not only the antero-posterior but also the transverse diameter of the chest. Further, on account

of the resistance of the sternum, the angles between the ribs and their cartilages are, in the elevation of the ribs, somewhat opened out, and thus also the transverse as well as the antero-posterior diameter somewhat increased. In several ways, then, the elevation of the ribs enlarges the dimensions of the chest.

The ribs are raised by the contraction of certain muscles. Of these the external intercostals are the most important. Even in the case of two isolated ribs such as the fifth and sixth, the contraction of the external intercostal muscle of the intervening space raises the two ribs, thus bringing them towards the position in which the fibres of the muscle have the shortest length, viz. the horizontal one. This elevating action is further favoured by the fact that the first rib is less moveable than the second, and so affords a comparatively fixed base for the action of the muscles between the two, the second in turn supporting the third and so on, while the scaleni muscles in addition serve to render fixed, or to raise, the first two ribs.

So that in normal respiration, the act begins probably by a contraction of the scaleni. The first two ribs being thus fixed, the contraction of the series of intercostal muscles acts to the greatest advantage. From the direction and attachments of their fibres, those portions of the internal intercostal muscles which lie between the sternal cartilages of the upper seven ribs, also seem calculated to raise the ribs by their contractions; and direct observation, as far as it goes, is in favour of their possessing such an action. Whether the rest of the internal intercostals can be considered as elevators of the ribs is more than doubtful.

In the well-known model invented by Bernoulli and adopted by Hamberger, consisting of two rigid bars, representing the ribs, moving vertically by means of their articulations with an upright representing the spine and connected at their free ends by a piece representing the sternum, it is undoubtedly true that stretched elastic bands attached to the bars in such a way as to represent respectively the external and internal intercostals, viz. sloping in the one case downwards and forwards and in the other downwards and backwards, do, on being left free to contract, in the former case elevate and in the latter depress the ribs.

Such a model however does not fairly represent the natural conditions of the ribs, which are not straight and rigid, but peculiarly curved and of varying elasticity, capable moreover of rotation on their own axes, and having their movements determined by the characters of their vertebral articulations. On the other hand, the absence of the external muscles in front and the internal behind seems to point to their both acting towards the same end, and the experiments of Duchenne, though not conclusive, support the view that the internal act as elevators along their whole course. The mechanical conditions are in the case of these muscles so complex, and the deduction of their actions from simple mechanical principles so exceedingly difficult and dangerous, and the want of direct exact empirical knowledge so great, that it must at present be left an open question, whether the internal intercostals, or at least certain parts of them, are inspiratory or expiratory or in a certain sense neither. Haller may be

regarded as the leader of those who regard them as inspiratory, while Hamberger was the first who successfully advocated the perhaps more commonly adopted view that those parts of the intercostals which lie between the osseous ribs act as depressors, and must in consequence be regarded as expiratory.

Next in importance to the external intercostals come the levatores costarum, which, though small muscles, are able, from the nearness of their costal insertions to the fulcrum, to produce considerable movement of the sternal ends of the ribs. The external intercostals and the levatores costarum with the scaleni may fairly be said to be the elevators of the ribs, *i. e.* the chief muscles of costal inspiration in normal breathing.

Additional space in the transverse diameter is afforded probably by the rotation of the ribs on an antero-posterior axis; but this movement is quite subsidiary and unimportant. When the chest is at rest, the ribs are somewhat inclined with their lower borders directed inwards as well as downwards. When they are drawn up by the action of the intercostal muscles, their lower borders are everted. Thus their flat sides are presented to the thoracic cavity, which is thereby slightly increased in width.

Laboured Inspiration. When respiration becomes laboured, other muscles are brought into play. The scaleni are strongly contracted, so as to raise or at least give a very fixed support to the first and second ribs. In the same way the serratus posticus superior, which descends from the fixed spine in the lower cervical and upper dorsal regions to the second, third, fourth and fifth ribs, by its contractions raises those ribs. In laboured breathing a function of the lower false ribs, not very noticeable in easy breathing, comes into play. They are depressed, retracted, and fixed, thereby giving increased support to the diaphragm, and directing the whole energies of that muscle to the vertical enlargement of the chest. In this way the serratus posticus inferior, which passes upward from the lumbar aponeurosis to the last four ribs, by depressing and fixing those ribs becomes an adjuvant inspiratory muscle. The quadratus lumborum and lower portions of the sacro-lumbalis may have a similar function.

All these muscles may come into action even in breathing which, deeper than usual, can hardly perhaps be called laboured. When however the need for greater inspiratory efforts becomes urgent, all the muscles which can, from any fixed point, act in enlarging the chest, come into play. Thus the arms and shoulder being fixed, the serratus magnus passing from the scapula to the middle of the first eight or nine ribs, the pectoralis minor passing from the coracoid to the front parts of the third, fourth, and fifth ribs, the pectoralis major passing from the humerus to the costal cartilages, from the second to the sixth, and that portion of the latissimus dorsi which passes from the humerus to the last three ribs, all serve to elevate the ribs and thus to enlarge the chest. The sterno-mastoid and other muscles

passing from the neck to the sternum, are also called into action. In fact, every muscle which by its contraction can either elevate the ribs or contribute to the fixed support of muscles which do elevate the ribs, such as the trapezius, levator anguli scapulæ and rhomboidei by fixing the scapula, may, in the inspiratory efforts which accompany dyspnoea, be brought into play.

Expiration. In normal easy breathing, expiration is in the main a simple effect of elastic reaction. By the inspiratory effort the elastic tissue of the lungs is put on the stretch; so long as the inspiratory muscles continue contracting, the tissue remains stretched, but directly those muscles relax, the elasticity of the lungs comes into play and drives out a portion of the air contained in them. Similarly the elastic sternum and costal cartilages are by the elevation of the ribs put on the stretch: they are driven into a position which is unnatural to them. When the intercostal and other elevator muscles cease to contract, the elasticity of the sternum and costal cartilages causes them to return to their previous position, thus depressing the ribs, and diminishing the dimensions of the chest. When the diaphragm descends, in pushing down the abdominal viscera, it puts the abdominal walls on the stretch; and hence, when at the end of inspiration the diaphragm relaxes, the abdominal walls return to their place, and by pressing on the abdominal viscera, push the diaphragm up again into its position of rest. Expiration then is, in the main, simple elastic reaction; but it is obvious that since external work has been effected by the respiratory act, viz. the movement of the column of air, the reaction of expiration must fall short of the action of inspiration; there must be some, though it may be a very slight, additional expenditure of energy to bring the chest completely to its former condition. This is, as we have seen, supposed by many to be afforded by the internal intercostals acting as depressors of the ribs. If these do not act in this way, we may suppose that the elastic return of the abdominal walls is accompanied and assisted by a contraction of the abdominal muscles. The triangularis sterni, the effect of whose contraction is to pull down the costal cartilages, may also be regarded as an expiratory muscle.

When expiration becomes laboured, the abdominal muscles become important expiratory agents. By pressing on the contents of the abdomen, they thrust them and the diaphragm up into the chest, the vertical diameter of which is thereby lessened, and by pulling down the sternum and the middle and lower ribs they lessen also the cavity of the chest in its antero-posterior and transverse diameters. They are in fact the chief expiratory muscles, though they are doubtless assisted by the serratus posticus inferior and portions of the sacro-lumbalis, since when the diaphragm is not contracting, the depression of the lower ribs which the contraction of these muscles causes, serves only to narrow the chest. As expiration becomes more and more forced, every muscle in the body which can

either by contracting depress the ribs, or press on the abdominal viscera, or afford fixed support to muscles having those actions, is called into play.

Facial and Laryngeal Respiration. The thoracic respiratory movements are accompanied by associated respiratory movements of other parts of the body, more particularly of the face and of the glottis.

In normal healthy respiration the current of air which passes in and out of the lungs, travels, not through the mouth but through the nose, viz., chiefly through the lower nasal meatus. The ingoing air, by exposure to the vascular mucous membrane of the narrow and winding nasal passages, is more efficiently warmed than it would be if it passed through the mouth; and at the same time the mouth is thereby protected from the desiccating effect of the continual inroad of comparatively dry air.

During each inspiratory effort the nostrils are expanded, probably by the action of the dilatores naris, and thus the entrance of air facilitated. The return to their previous condition during expiration is effected by the elasticity of the nasal cartilages, assisted perhaps by the compressores naris. This movement of the nostrils, perceptible in many people, even during tranquil breathing, becomes very obvious in laboured respiration.

When the mouth is closed, the soft palate which is held somewhat tense, is swayed by the respiratory current, but entirely in a passive manner, and it is not until the larynx is reached by the ingoing air that any active movements are met with. When the larynx is examined with the laryngoscope, it is frequently seen that, while during inspiration the glottis is widely open, with each expiration the arytenoid cartilages approach each other so as to narrow the glottis, the cartilages of Santorini projecting inwards at the same time. Thus, synchronous with the respiratory expansion and contraction of the chest, and the respiratory elevation and depression of the alæ nasi, there is a rhythmic widening and narrowing of the glottis. Like the movements of the nostril, this respiratory action of the glottis is much more evident in laboured than in tranquil breathing. Indeed in the latter case it is frequently absent. The manner in which this rhythmic opening and narrowing is effected will be described when we come to study the production of the voice. Whether there exists a rhythmic contraction and expansion of the trachea and bronchial passages effected by means of the plain muscular tissue of those organs and synchronous with the respiratory movements of the chest, is uncertain¹.

SEC. 2. CHANGES OF THE AIR IN RESPIRATION.

During its stay in the lungs, or rather during its stay in the bronchial passages, the tidal air (by means of diffusion chiefly) effects exchanges with the stationary air; in consequence the expired air differs from inspired air in several important particulars.

1. The temperature of expired air is variable, but under ordinary circumstances is higher than that of the inspired air. At an average temperature of the atmosphere, for instance at about 20° C., the

¹ Cf. Horvath, *Pflüger's Archiv*, xiii. (1876) p. 508.

temperature of expired air is, in the mouth 33·9°, in the nose 35·3°. When the external temperature is low, that of the expired air sinks somewhat, but not to any great extent, thus at -6·3° C. it is 29·8° C. When the external temperature is high, the expired air may become cooler than the inspired, thus at 41·9° it was found by Valentin to be 38·1°. The exact temperature in fact depends on the relative temperatures of the blood and inspired air, and on the depth and rate of breathing.

2. The expired air is loaded with aqueous vapour. The point of saturation of any gas, that is, the utmost quantity of water which any given volume of gas can take up as aqueous vapour, varies with the temperature, being higher with the higher temperature. For its own temperature expired air is according to most observers saturated with aqueous vapour. According to Edward Smith it is, when fasting, only half saturated.

3. When the total quantity of tidal air given out at any expiration is compared with that taken in at the corresponding inspiration, it is found that, both being dried and measured at the same pressure, the expired air is less in volume than the inspired air, the difference amounting to about $\frac{1}{40}$ th or $\frac{1}{30}$ th of the volume of the latter. Hence, when an animal is made to breathe in a confined space, the atmosphere is absolutely diminished, as was observed so long ago as 1674 by Mayow. The approximate equivalence in volume between inspired and expired air arises from the fact that the volume of any given quantity of carbonic acid is equal to the volume of the oxygen consumed to produce it; the slight falling short of the expired air is due to the circumstance that all the oxygen inspired does not reappear in the carbonic acid expired, some having formed other combinations.

4. The expired air contains about 4 or 5 p. c. less oxygen, and about 4 p. c. more carbonic acid than the inspired air, the quantity of nitrogen suffering but little change. Thus

	oxygen.	nitrogen.	carbonic acid.
Inspired air contains	20·81	79·15	·04
Expired „ „	16·033	79·557	4·380.

The quantity of nitrogen in the expired air is sometimes found to be greater, as in the table above, but sometimes less, than that of the inspired air.

W. Edwards thought that nitrogen was absorbed in cold, and thrown out in warm weather. W. Müller observed that in an atmosphere consisting entirely of nitrogen, an absorption, and in one devoid of nitrogen or containing little nitrogen, an escape of nitrogen took place; a result which appears probable.

In a single breath the air is richer in carbonic acid (and poorer in oxygen), at the end than at the beginning. Hence the longer the breath is held, the greater the pause between inspiration and expiration, the higher the percentage of carbonic acid in the expired air. Thus Becher found

that by increasing the pause from 0 to 100 seconds, the percentage was raised from 3.6 to 7.5. The rate of increase however continually diminishes, being greatest at the beginning of the period.

When the rate of breathing remains the same, by increasing the depth of the breathing the percentage of carbonic acid in each breath is lowered, but the total quantity of carbonic acid expired in a given time is increased. Similarly, when the depth of breath remains the same, by quickening the rate the percentage of carbonic acid in each breath is lowered, but the quantity expired in a given time is increased.

The variations in both the consumption of oxygen and production of carbonic acid, due to variations in pressure, will be considered in connection with the respiratory changes of blood.

Taking, as we have done, at 500 c.c. the amount of tidal air passing in and out of the chest of an average man, such a person will expire about 22 c.c. of carbonic acid at each breath; this, reckoning the rate of breathing at 17 a minute, would give over 500 litres of carbonic acid for the day's production. By actual experiment, however, Pettenkofer and Voit, of whose researches we shall have to speak hereafter, determined the total daily excretion of carbonic acid in an average man to be 800 grms., *i.e.* rather more than 400 litres (406), containing 218.1 grms. carbon, and 581.9 grms. oxygen, the oxygen actually consumed at the same time being about 700 grms. This amount represents the gases given out and taken in, not by the lungs only, but by the whole body; but the amount of carbonic acid given out by the skin is, as we shall see, very slight (10 grms. or even less), so that 800 grms. may be taken as the average production of carbonic acid by an average man. The quantity however, both of oxygen consumed and of carbonic acid given out, is subject to very wide variations, thus in Pettenkofer and Voit's observations, the daily quantity of carbonic acid varied from 686 to 1285 grms., and that of the oxygen from 594 to 1072 grms. These variations and their causes will be discussed when we come to deal with the problems of nutrition.

The quantity of carbonic acid produced and oxygen consumed increases in man from birth up to about thirty years and after that diminishes. In the female, the quantity, always less than that of man, increases up to puberty, remains during the menstrual life at a standstill, and after the climacteric declines.

5. Besides carbonic acid, expired air contains various impurities, many of an unknown nature, and all in small amounts. Ammonia has been detected in expired air, even in that taken directly from the trachea, in which case its presence could not be due to decomposing food lingering in the mouth. According to Lossen, the amount given off in ordinary respiration in 24 hours is .014 gm. When the expired air is condensed by being conveyed into a cooled receiver, the aqueous product is found to contain organic matter, and rapidly to putrefy. The organic substances thus shewn to be present in the expired air are the cause in part of the odour of breath. It is

probable that many of them are of a poisonous nature; for an atmosphere containing simply 1 p. c. of carbonic acid (with a corresponding diminution of oxygen) has very little effect on the animal economy, whereas an atmosphere in which the carbonic acid has been raised to 1 p. c. by breathing, is highly injurious. In fact, air rendered so far impure by breathing that the carbonic acid amounts to .08 p. c. is distinctly unwholesome, not so much on account of the carbonic acid, as of the accompanying impurities. Since these impurities are of unknown nature and cannot be estimated, the easily determined carbonic acid is usually taken as the measure of their presence. We have seen that the average man loads, at each breath, 500 c. c. of air with carbonic acid to the extent of 4 p. c. He will accordingly at each breath load 2 litres to the extent of 1 p. c.; and in one hour, if he breathe 17 times a minute, will load rather more than 2000 litres to the same extent. At the very least then a man ought to be supplied with this quantity of air hourly; and if the air is to be kept fairly wholesome, that is with the carbonic acid reduced to .1 p. c., he should have ten times as much.

SEC. 3. THE RESPIRATORY CHANGES IN THE BLOOD.

While the air in passing in and out of the lungs is thus robbed of a portion of its oxygen, and loaded with a certain quantity of carbonic acid, the blood as it streams along the pulmonary capillaries undergoes important correlative changes. As it leaves the right ventricle it is venous blood of a dark purple or maroon colour; when it falls into the left auricle, it is arterial blood of a bright scarlet hue. In passing through the capillaries of the body from the left to the right side of the heart, it is again changed from the arterial to the venous condition. We have to inquire, What are the essential differences between arterial and venous blood, by what means is the venous blood changed into arterial in the lungs, and the arterial into venous in the rest of the body, and what relations do these changes in the blood bear to the changes in the air which we have already studied?

The facts, that venous blood at once becomes arterial on being exposed to or shaken up with air or oxygen, and that arterial blood becomes venous when kept for some little time in a closed vessel, or when submitted to a current of some indifferent gas such as nitrogen or hydrogen, prepare us for the statement that the fundamental difference between venous and arterial blood is in the relative proportion of the oxygen and carbonic acid gases contained in each. From both, a certain quantity of gas can be extracted by means which do not otherwise materially alter the constitution of the blood; and this gas when obtained from arterial blood is found to contain more oxygen and less carbonic acid than that obtained from venous blood. This is the real differential character of the

two bloods; all other differences are either, as we shall see to be the case with the colour, dependent on this, or are unimportant and fluctuating.

If the quantity of gas which can be extracted by the mercurial air-pump from 100 vols. of blood be measured at 0° C., and a pressure of 760 mm., it is found to amount, in round numbers, to 60 vols.¹

The vacuum produced by the ordinary mechanical air-pump is insufficient to extract all the gas from blood. Hence it becomes necessary to use either a large Torricellian vacuum or a Sprengel's pump. In the former (Fig. 40) case two large globes of glass, one fixed and the other moveable, connected by a flexible tube; the fixed globe is made to communicate by means of air-tight stopcocks alternately with a receiver containing the blood, and with a receiver to collect the gas. When the moveable globe filled with mercury is raised above the fixed one, the mercury from the former runs into and completely fills the latter, the air previously present being driven out. After adjusting the cocks, the moveable globe is then depressed thirty inches below the fixed one, in which the consequent fall of the mercury produces an almost complete vacuum. By turning the proper cock this vacuum is put into connection with the receiver containing the blood, which thereupon becomes proportionately exhausted. By again adjusting the cocks and once more elevating the moveable globe, the gas thus extracted is driven out of the fixed globe into a receiver, and the vacuum once more established. The operation is repeated as long as gas continues to be given off from the blood. This form of pump, introduced by Ludwig, or a modification of it, with drying apparatus, employed by Pflüger, is the one which has been hitherto most extensively used; but a Sprengel's pump is preferred by some.

The average composition of this gas is in the two kinds of blood as follows:

From 100 vols.	may be obtained		
	Of oxygen,	of carbonic acid,	of nitrogen.
Of Arterial Blood,	20 (16) vols.	39 (30) vols.	1 to 2 vols.
Of Venous Blood,	8 to 12 (6 to 10) vols.	46 (35) vols.	1 to 2 vols.
all measured at 760 mm. and 0° C. ²			

It will be convenient to consider the relations of each of these gases separately.

The relations of Oxygen in the Blood.

When a liquid such as water is exposed to an atmosphere containing a gas such as oxygen, some of the oxygen will be dissolved in the water, that is to say will be absorbed from the

¹ Or, at a pressure of 1 metre, about 50 vols.

² The numbers in brackets represent in round numbers the same amounts measured, according to the present German method, at a pressure of 1 metre.

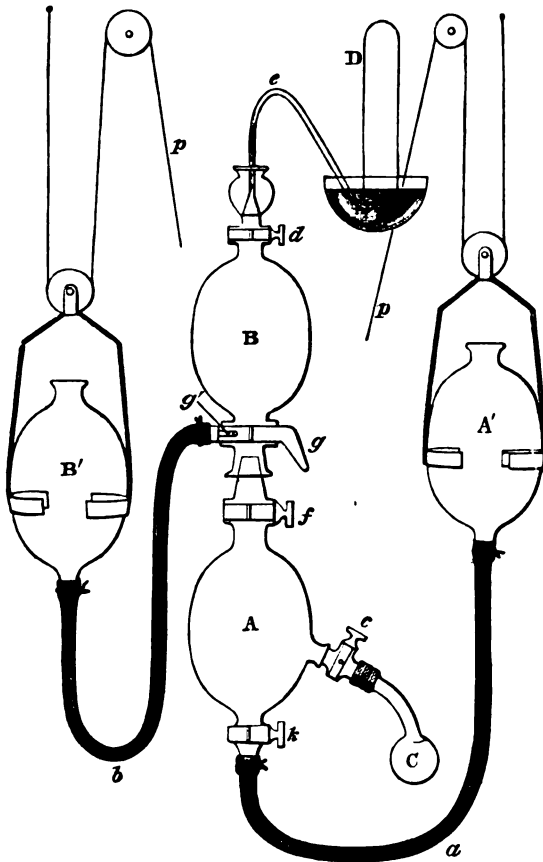

FIG. 40. DIAGRAMMATIC ILLUSTRATION OF LUDWIG'S MERCURIAL GAS PUMP.

A and B are two glass globes, connected by strong india-rubber tubes, *a* and *b*, with two similar glass globes A' and B'. A is further connected by means of the stopcock *c* with the receiver C containing the blood (or other fluid) to be analysed, and B by means of the stopcock *d* and the tube *e* with the receiver D for receiving the gases. A and B are also connected with each other by means of the stopcocks *f* and *g*, the latter being so arranged that B also communicates with B' by the passage *g'*. A' and B' being full of mercury and the cocks *k*, *f*, *g*, and *d* being open but *c* and *g'* closed, on raising A' by means of the pulley *p* the mercury of A' fills A, driving out the air contained in it, into B, and so out through *e*. When the mercury has risen above *g*, *f* is closed, and *g'* being opened, B' is in turn raised till B is completely filled with mercury, all the air previously in it being driven out through *e*. Upon closing *d*, and lowering B', the whole of the mercury in B falls in B', and a vacuum consequently is established in B. On closing *g'*, but opening *g*, *f*, and *k* and lowering A', a vacuum is similarly established in A and in the junction between A and B. If the cock *c* be now opened the gases of the blood in C escape into the vacuum of A and B. By raising A', after the closure of *c*, and opening of *d*, the gases so set free are driven from A into B, and by the raising of B' from B, through *e* into the receiver D, standing over mercury.

atmosphere. The quantity which is so absorbed will depend on the quantity of oxygen which is in the atmosphere above; that is to say on the pressure of the oxygen; the greater the pressure of the oxygen, the larger the amount which will be absorbed. If on the other hand water, already containing a good deal of oxygen dissolved in it, be exposed to an atmosphere containing little or no oxygen, the oxygen will escape from the water into the atmosphere. The oxygen in fact which is dissolved in the water is in a state of tension, the degree of tension depending on the quantity dissolved; and when water containing oxygen dissolved in it is exposed to any atmosphere, the point whether the oxygen escapes from the water into the atmosphere, or passes from the atmosphere into the water, depends on whether the tension of the oxygen in the water is greater or less than the pressure of the oxygen in the atmosphere. Hence when water is exposed to oxygen, the oxygen either escapes or is absorbed until equilibrium is established between the pressure of the oxygen in the atmosphere above and the tension of the oxygen in the water below. This result is, as far as mere absorption and escape are concerned, quite independent of what other gases are present in the water or in the atmosphere. Suppose a half-litre of water were lying at the bottom of a two-litre flask, and that the atmosphere in the flask above the water was one-third oxygen; it would make no difference, as far as the absorption of oxygen by the water was concerned, whether the remaining two-thirds of the atmosphere was carbonic acid, or nitrogen, or hydrogen, or whether the space above the water was a vacuum filled to one-third with pure oxygen. Hence it is said that the absorption of any gas depends on the *partial pressure* of that gas in the atmosphere to which the liquid is exposed. This is true not only of oxygen and water, but of all gases and liquids which do not enter into chemical combination with each other. Different liquids will of course absorb different gases with differing readiness, but with the same gas and the same liquid, the amount absorbed will depend directly on the partial pressure of the gas. It should be added that the process is much influenced by temperature. Hence to state the matter generally, the absorption of any gas by any liquid, will depend on the nature of the gas, the nature of the liquid, the pressure of the gas, and the temperature at which both stand.

Now it might be supposed, and indeed was once supposed, that the oxygen in the blood was simply dissolved by the blood. If this were so, then the amount of oxygen present in any given quantity of blood exposed to any given atmosphere, ought to rise and fall steadily and regularly as the partial pressure of oxygen in that atmosphere is increased or diminished. But this is found not to be the case. If we expose blood containing little or no oxygen to a succession of atmospheres containing increasing quantities of oxygen, we find that at first there is a very rapid absorption of the available oxygen, and then this somewhat suddenly ceases or becomes very small; and

if on the other hand we submit arterial blood to successively diminishing pressures, we find that for a long time very little is given off, and then suddenly the escape becomes very rapid. The absorption of oxygen by blood does not follow the general law of absorption according to pressure. The phenomena on the other hand suggest the idea that the oxygen in the blood is in some particular combination with a substance or some substances present in the blood, the combination being of such a kind that dissociation readily occurs at certain pressures and certain temperatures. What is that substance or what are those substances?

If serum, free from red corpuscles, be used in such absorption experiments, it is found that as compared with the entire blood, very little oxygen is absorbed, about as much as would be absorbed by the same quantity of water; but such as is absorbed does follow the law of pressures. In natural arterial blood the quantity of oxygen which can be obtained from serum is exceedingly small; it does not amount to half a volume in one hundred volumes of the entire blood to which the serum belonged. It is evident that the oxygen which is present in blood is in some way or other peculiarly connected with the red corpuscles. Now the distinguishing feature of the red corpuscles is the presence of hæmoglobin. We have already seen (p. 13) that this constitutes 90 per cent. of the dried red corpuscles. There can be *a priori* little doubt that this must be the substance with which the oxygen is associated; and to the properties of this body we must therefore direct our attention.

Hæmoglobin; its properties and derivatives.

When separated from the other constituents of the serum, hæmoglobin appears as a substance, either amorphous or crystalline, readily soluble in water (especially in warm water) and in serum.

Since it is soluble in serum, and since the identity of the crystals observed occasionally within the corpuscles with those obtained in other ways shews that the hæmoglobin as it exists in the corpuscle is the same thing as that which is artificially prepared from blood, it is evident that some peculiar relationship between the stroma and the hæmoglobin must, in natural blood, keep the latter from being dissolved by the serum. Hence in preparing hæmoglobin it is necessary first of all to break up the corpuscles. This may be done by the addition of chloroform or of bile salts, or better, by repeatedly freezing and thawing. It is also of advantage previously to remove the alkaline serum, so as to operate only on the red corpuscles. The corpuscles being thus broken up, an aqueous solution of hæmoglobin is the result. The alkalinity of the solution, when present, being reduced by the cautious addition of dilute acetic acid, and the solvent power of the aqueous medium being diminished by the addition of one fourth its bulk of alcohol, the mixture, set aside in a temperature of 0° C. still further to reduce the solubility of the hæmoglobin, readily crystallizes, when the blood used is that of the dog, cat, horse, rat, guinea-pig, &c.

The crystals may be separated by filtration, redissolved in water and re-crystallized.

Hæmoglobin from the blood of the rat, guinea-pig, squirrel, hedgehog, horse, cat, dog, goose, and some other animals, crystallizes readily, the crystals being generally slender four-sided prisms, belonging to the rhombic system, and often appearing quite acicular. The crystals from the blood of the guinea-pig are octahedral, but also belong to the rhombic system; those of the squirrel are six-sided plates. The blood of the ox, sheep, rabbit, pig, and man, crystallizes with difficulty. Why these differences exist is not known; but the composition, and the amount of water of crystallization, vary somewhat in the crystals obtained from different animals. In the dog, the percentage composition of the crystals is, according to Hoppe-Seyler¹, C. 53·85, H. 7·32, N. 16·17, O. 21·84, S. 0·39, Fe ·43, with 3 to 4 per cent. of water of crystallization. It will thus be seen that hæmoglobin contains iron, in addition to the other elements usually present in proteid substances.

The crystals, when seen under the microscope, have the same bright scarlet colour as arterial blood has to the naked eye; when seen in a mass they naturally appear darker. An aqueous solution of hæmoglobin, obtained by dissolving purified crystals in distilled water, has also the same bright arterial colour. A tolerably dilute solution placed before the spectroscope is found to absorb certain rays of light in a peculiar and characteristic manner. A portion of the red end of the spectrum is absorbed, as is also a much larger portion of the blue end; but what is most striking is the presence of two strongly marked absorption bands, lying between the solar lines D and E. (See Fig. 41.) Of these the one α , towards the red side, is the thinnest, but the most intense; its middle lies at some little distance to the blue side of D. The other, β , much broader, lies a little to the red side of E, its blue-ward edge, even in moderately dilute solutions, coming close up to that line. Each band is thickest in the middle, and gradually thins away at the edges. These two absorption bands are extremely characteristic of a solution of hæmoglobin. Even in very dilute solutions they are visible (they may be seen in a thickness of 1 cm. in a solution containing 1 grm. of hæmoglobin in 10 litres of water), and that when scarcely any of the extreme red end, and very little of the blue end, is cut off. They then appear not only faint but narrow. As the strength of the solution is increased, the bands broaden, and become more intense; at the same time both the red end, and still more the blue end of the whole spectrum, are encroached upon. This may go on until the two absorption bands become fused together into one broad band. The only rays of light which then pass through the hæmoglobin solution are those in the green between the united bands and the general absorption at the blue end, and those in the

¹ *Untersuch.*, III. (1868) 370.

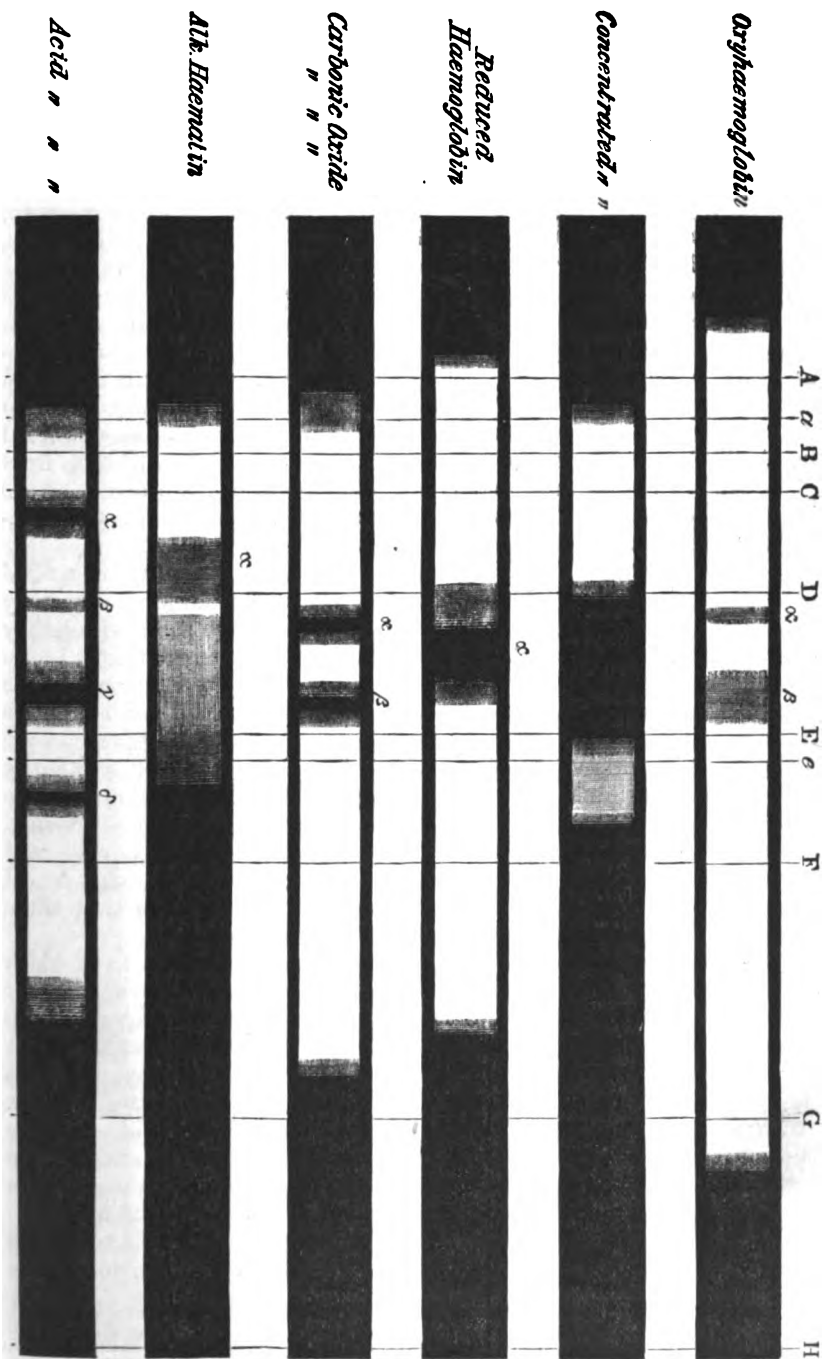

F. P.

18

FIG. 41. THE SPECTRA OF HÆMOGLOBIN AND SOME OF ITS DERIVATIVES SHOWN IN REFERENCE TO FRAUNHOFER'S LINES.

The first spectrum of oxyhæmoglobin is that of an exceedingly dilute solution. That of a solution intermediate between the first and second spectra would resemble in the *intensity* of its absorption-bands the spectrum given as that of carbonic oxide hæmoglobin.

red between the band and the general absorption at the red end (see Fig. 41). If the solution be still further increased in strength, the interval on the blue side of the band becomes absorbed also, so that the only rays which pass through are the red rays lying to the red side of D; these are the last to disappear, and hence the natural red colour of the solution as seen by transmitted light. Exactly the same appearances are seen when crystals of hæmoglobin are examined with a microspectroscope. They are also seen when arterial blood itself (diluted with saline solutions so that the corpuscles remain in as natural condition as possible) is examined with the spectroscope, as well as when a drop of blood, which from the necessary exposure to air is always arterial, is examined with the microspectroscope. In fact, the spectrum of hæmoglobin is the spectrum of normal arterial blood.

When crystals of hæmoglobin, prepared in the way described above, are subjected to the vacuum of the mercurial air-pump, they give off a certain quantity of oxygen, and at the same time they change in colour. The quantity of oxygen given off is definite, 1 grm. of the crystals giving off 1·76¹ c.cm. of oxygen. In other words, the crystals of hæmoglobin over and above the oxygen which enters intimately into their composition, (and which alone is given in the elementary composition stated on p. 272), contain another quantity of oxygen, which is in loose combination only, and which may be dissociated from them by establishing a sufficiently low pressure. The change of colour which ensues when this loosely combined oxygen is removed, is characteristic; the crystals become darker and more of a purple hue, and at the same time dichroic, so that while the thin edges appear green, the thicker ridges are purple.

An ordinary solution of hæmoglobin, like the crystals from which it is formed, contains a definite quantity of oxygen in a similarly peculiar loose combination; this oxygen it also gives up at a sufficiently low pressure, becoming at the same time of a purplish hue. This loosely combined oxygen may also be removed by passing a stream of hydrogen or other indifferent gas through the solution, whereby dissociation is effected. It may also be got rid of by the use of reducing agents. Thus if a few drops of ammonium sulphide or of an alkaline solution of ferrous sulphate, kept from precipitation by the presence of tartaric acid², be added to a solution of hæmoglobin, or even to an unpurified solution of blood corpuscles such as is afforded by the washings from a blood clot, the oxygen in loose com-

¹ Or, 1·34 measured at a pressure of 1 metre.

² Stokes, *Proc. Roy. Soc.* XIII. (1864) 355.

bination with the hæmoglobin is immediately seized upon by the reducing agent. This may be recognized at once, without submitting the fluid to the air-pump, by a characteristic change of colour; from a bright scarlet the solution becomes of a purplish claret colour, when seen in any thickness, but green when sufficiently thin: the colour of the reduced solution is exactly like that of the crystals from which the loose oxygen has been removed by the air-pump.

Examined by the spectroscope, this reduced solution, or solution of reduced hæmoglobin as we may now call it, offers a spectrum (Fig. 41) entirely different from that of the unreduced solution. The two absorption bands have disappeared, and in their place there is seen a single, much broader, but at the same time much fainter band α , whose middle occupies a position about midway between the two absorption bands of the unreduced solution, though the red-ward edge of the band shades away rather farther towards the red than does the other edge towards the blue. At the same time the general absorption of the spectrum is different from that of the unreduced solution; less of the blue end is absorbed. Even when the solutions become tolerably concentrated, the bluish green rays to the blue side of the single band still pass through. Hence the difference in colour between hæmoglobin which retains the loosely combined oxygen¹, and hæmoglobin which has lost its oxygen and become reduced. In tolerably concentrated solutions, or tolerably thick layers, the former lets through the red and the orange yellow rays, the latter the red and the bluish green rays. Accordingly, the one appears scarlet, the other purple. In dilute solutions, or in a thin layer, the reduced hæmoglobin lets through so much of the green rays that they preponderate over the red, and the resulting impression is one of green. In the unreduced hæmoglobin or oxy-hæmoglobin, the potent yellow which is blocked out in the reduced hæmoglobin makes itself felt, so that a very thin layer of hæmoglobin, as in a single corpuscle seen under the microscope, appears yellow rather than red.

When the hæmoglobin solution (or crystal) which has lost its oxygen by the action either of the air-pump or of a reducing agent or by the passage of an indifferent gas, is exposed to air containing oxygen, an absorption of oxygen at once takes place. If sufficient oxygen be present, the whole of the hæmoglobin seizes upon its complement, each gramme taking up in combination 1.76 (1.34) c.c.m. of oxygen; if there be an insufficient quantity, the hæmoglobin takes up all there is, so that while some of the hæmoglobin gets its allowance, the remainder continues reduced. If the amount of oxygen be sufficient, the solution (or crystal), as it takes up the oxygen, regains its bright scarlet colour, and its characteristic absorption spectrum, the single band being replaced by the two. Thus if a

¹ For brevity's sake we may call the hæmoglobin containing oxygen in loose combination, *oxyhæmoglobin*, and the hæmoglobin from which this loosely combined oxygen has been removed, *reduced hæmoglobin* or simply *hæmoglobin*.

solution of oxyhæmoglobin in a test-tube after being reduced by the ferrous salt, and shewing the purple colour and the single band, be shaken up with air for a second or two, the bright scarlet colour at once returns, and when the fluid is placed before the spectroscope, it is seen that the single faint broad band of the reduced hæmoglobin has wholly disappeared, and that in its place are the two sharp thinner bands of the oxyhæmoglobin. If left to stand in the test-tube the quantity of reducing agent still present is generally sufficient again to rob the hæmoglobin of the oxygen thus newly acquired, and soon the scarlet hue fades back again into the purple, the two bands giving place to the one. Another shake and exposure to air will however again bring back the scarlet hue and the two bands; and once more these may disappear. In fact, a few drops of the reducing fluid will allow this game of taking oxygen from the air and giving it up to the reducer to be played over and over again, and at each turn of the game the colour shifts from scarlet to purple, and from purple to scarlet, while the two bands exchange for the one, and the one for the two.

Colour of venous and arterial Blood. Evidently we have in these properties of hæmoglobin an explanation of at least one-half of the great respiratory process, and they teach us the meaning of the change of colour which takes place when venous blood becomes arterial or arterial venous. In venous blood, as it issues from the right ventricle, the oxygen present is insufficient to satisfy the whole of the hæmoglobin of the red corpuscles; much reduced hæmoglobin is present, hence the purple colour of venous blood.

When ordinary venous blood diluted without access of oxygen, is brought before the spectroscope, the two bands of oxyhæmoglobin are seen. This is explained by the fact that in a mixture of oxyhæmoglobin and (reduced) hæmoglobin, the two sharp bands of the former are always much more readily seen than the much fainter band of the latter. Now in ordinary venous blood there is always some loose oxygen, and therefore always some, indeed a considerable quantity, of oxyhæmoglobin as well as (reduced) hæmoglobin. It is only in the last stages of asphyxia that all the loose oxygen of the blood disappears; and then the two bands of the oxyhæmoglobin vanish too.

As the blood passes through the capillaries of the lungs, this reduced hæmoglobin takes from the pulmonary air its complement of oxygen, all or nearly all the hæmoglobin of the red corpuscles becomes oxy-hæmoglobin, and the purple colour forthwith shifts into scarlet.

The hæmoglobin of arterial blood is saturated or nearly saturated with oxygen. By increasing the pressure of the oxygen, an additional quantity may be driven into the blood, but this is effected by simple absorption. The quantity so added is extremely small compared with the total quantity combined with the hæmoglobin, but its physiological importance is increased by its being present at a high tension.

Passing from the left ventricle to the capillaries, some of the oxyhæmoglobin gives up its oxygen to the tissues, becomes reduced hæmoglobin, and the blood in consequence becomes once more venous, with a purple hue. Thus the red corpuscles by virtue of their hæmoglobin are emphatically oxygen-carriers. Undergoing no intrinsic change in itself, the hæmoglobin combines in the lungs with oxygen, which it carries to the tissues; these, more greedy of oxygen than itself, rob it of its charge, and the reduced hæmoglobin hurries back to the lungs in the venous blood for another portion. The change from venous to arterial blood is then in part (for as we shall see there are other events as well) a peculiar combination of hæmoglobin with oxygen, while the change from arterial to venous is, in part also, a reduction of oxyhæmoglobin; and the difference of colour between venous and arterial blood depends almost entirely on the fact that the reduced hæmoglobin of the former is of purple colour, while the oxyhæmoglobin of the latter is of a scarlet colour.

There may be other causes of the change of colour, but these are wholly subsidiary and unimportant. When a corpuscle swells, its refractive power is diminished, and in consequence the number of rays which pass into and are absorbed by it, are increased at the expense of those reflected from its surface; anything therefore which swells the corpuscles, such as the addition of water, tends to darken blood, and anything, such as a concentrated saline solution, which causes the corpuscles to shrink, tends to brighten blood. Carbonic acid has apparently some influence in swelling the corpuscles, and therefore may aid in darkening the venous blood.

We have spoken of the combination of hæmoglobin with oxygen as being a peculiar one. The peculiarity consists in the facts that the oxygen may be associated and dissociated, without any general disturbance of the molecule of hæmoglobin, and that dissociation may be brought about very readily. Hæmoglobin combines in a wholly similar manner with other gases. If carbonic oxide be passed through a solution of hæmoglobin, a change of colour takes place, a peculiar bluish tinge making its appearance. At the same time the spectrum is altered; two bands are still visible, but on accurate measurement it is seen that they are placed more towards the blue end than are the otherwise similar bands of oxyhæmoglobin (see Fig. 41). When a known quantity of carbonic oxide gas is sent through a hæmoglobin solution, it will be found on examination that a certain amount of the gas has been retained, an equal volume of oxygen appearing in its place in the gas which issues from the solution. If the solution so treated be crystallized, the crystals will have the same characteristic colour, and give the same absorption spectrum as the solution; when subjected to the action of the mercurial pump, they will give off a definite quantity of carbonic oxide, 1 grm. of the crystals affording 1.76 (1.34) c.cm. of the gas. In fact, hæmoglobin combines loosely with carbonic oxide just as it does

with oxygen; but its affinity with the former is greater than with the latter. While carbonic oxide readily turns out oxygen, oxygen cannot so readily turn out carbonic oxide. Indeed, carbonic oxide has been used as a means of driving out and measuring the quantity of oxygen present in any given blood. This property of carbonic oxide explains its poisonous nature. When the gas is breathed, the reduced and the unreduced hæmoglobin of the venous blood unite with the carbonic oxide, and hence the peculiar bright red colour observable in the blood and tissues in cases of poisoning by this gas. The carbonic oxide hæmoglobin, however, is of no use in respiration; it is not an oxygen-carrier, nay more, it will not readily, though it does so slowly and eventually, give up its carbonic oxide for oxygen, when the gas no longer enters the chest and pure air is supplied. The organism is killed by suffocation, by want of oxygen, in spite of the bright red colour of the blood. As Bernard phrased it, the corpuscles are paralysed.

Hæmoglobin similarly forms a compound, having a characteristic spectrum with nitric oxide, more stable than that with carbonic oxide, 1 grm. of hæmoglobin uniting with 1.76 (1.34) c.cm. of the gas. In all these compounds, in fact, the same volume of gas unites with the same quantity of the substance, and all three compounds are isomorphous. Nitrous oxide reduces hæmoglobin. Compounds also exist between hæmoglobin and hydrocyanic acid.

Hæmoglobin is a so-called ozone-carrier. If to a mixture of ozonized turpentine (turpentine kept for some time) and tincture of guaiacum, a drop of blood or hæmoglobin solution be added, the turpentine at once oxidises the guaiacum and produces a blue colour; this, before the addition of the hæmoglobin, it is unable to do. If a drop of tincture of guaiacum (the experiment fails with many specimens of tincture) be spread out and allowed to dry on a piece of white filtering paper, and a drop of blood or hæmoglobin solution be placed on it, a blue ring is developed. This was held by A. Schmidt to indicate that the oxygen in combination with hæmoglobin was in an active, or ozonic condition. Since however the experiment fails when glass or even smooth paper is used instead of filtering paper, it is more than probable that the result is caused by a decomposition of the hæmoglobin due to the porous nature of the paper¹.

Although a crystalline body, hæmoglobin diffuses with great difficulty. This arises from the fact that it is in part a proteid body; it consists of a colourless proteid, associated with a coloured compound named *hæmatin*. All the iron belonging to the hæmoglobin is in reality attached to the hæmatin. A solution of hæmoglobin, when heated, coagulates, the exact degree at which the coagulation takes place depending on the amount of dilution; at the same time it turns brown from the setting free of the hæmatin. If a strong solution of hæmoglobin be treated with acetic (or other) acid, the same brown colour, from the appearance of hæmatin, is observed. The proteid constituent however is not

¹ Pflüger, *Pflüger's Archiv*, x. (1875) p. 252.

coagulated, but by the action of the acid passes into the state of acid-albumin. On adding ether to the mixture, and shaking, the hæmatin rises into the supernatant ether, which it colours a dark red, and which, examined with the spectroscope, is found to possess a well-marked spectrum, the spectrum of the so-called acid hæmatin of Stokes (Fig. 41). The proteid in the water below the ether appears in a coagulated form. In a somewhat similar manner alkalis split up hæmoglobin into a proteid constituent and hæmatin. The exact nature of the proteid constituent has not as yet been clearly determined; it was supposed to be globulin, hence the name hæmatoglobulin contracted into hæmoglobin. The proteid which is precipitated when a solution of hæmoglobin is exposed to the air, though belonging to the globulin family, has characters of its own. It has been named by Preyer' *globin*. It is free from ash. Hæmatin when separated from its proteid fellow, and purified, appears as a dark brown amorphous powder, having the probable composition of $C_{59}, H_{31}, N_4, Fe, O_5$. It is readily soluble in dilute alkaline solutions, and then gives a characteristic spectrum (Fig. 41).

An interesting feature in hæmatin is that its *alkaline* solution is capable of being reduced by reducing agents, the spectrum changing at the same time, and that the reduced solution will, like the hæmoglobin, take up oxygen again on being brought into contact with air or oxygen. This would seem to indicate that the oxygen-holding power of hæmoglobin is connected exclusively with its hæmatin constituent. By the action of strong sulphuric acid hæmatin may be robbed of all its iron. It still retains the feature of possessing colour, the solution of iron-free hæmatin being a dark rich brownish red; but is no longer capable of combining loosely with oxygen. This indicates that the iron is in some way associated with the peculiar respiratory functions of hæmoglobin; though it is obviously an error to suppose, as once was thought, that the change from venous to arterial blood consists essentially in a change from a ferrous to a ferric salt.

Though not crystallizable itself, hæmatin forms with hydrochloric acid a compound, occurring in minute rhombic crystals, the so-called hæmin crystals.

The spectrum of hæmatin in an alkaline solution (Fig. 41) gives one broad band to the red side of the line D. The blue end of the spectrum suffers much absorption, and since the characteristic single band is faint, and only seen in concentrated solutions, the whole appearance of the spectrum of hæmatin is far less striking than that of hæmoglobin. The solutions are dichroic, of a reddish brown in a thick, and of an olive green in a thin layer. The spectrum of reduced hæmatin is marked by two faint bands to the blue side of the single band of the unreduced hæmatin; there is at the same time less absorption of the blue end. The spectrum of acid hæmatin, *i. e.* of hæmatin prepared, as spoken of above, by treatment with acetic acid and ether, is marked by a very characteristic and easily seen band, α , in the red, to the blue side of C (Fig. 41). This

¹ *Die Blut Krystalle*, 1871.

hæmatin band readily appears when hæmoglobin is acted upon by weak acids, and hence is seen when carbonic acid is passed for some time through hæmoglobin. A wholly similar band, however, makes its appearance when blood is acted upon for some time by ammonium sulphide, or when blood is allowed to stand for any length of time, or after the action of weak alkalis; in these cases it is supposed to indicate the existence of a hypothetical body methæmoglobin, an intermediate stage which hæmoglobin is supposed to pass through on its way to be split up into hæmatin and the proteid body. When hæmatin or hæmoglobin is dissolved in concentrated sulphuric acid, a spectrum is obtained, on diluting with the acid, resembling but in some points differing from that of acid hæmatin as given in fig. 41. The iron-free hæmatin, obtained by precipitating with a large quantity of water the solution of hæmatin or hæmoglobin in concentrated sulphuric acid, also gives in ammoniacal and in acetic acid solutions spectra differing in minor points only from the same spectrum. Preyer¹ believes that Stokes' acid hæmatin, *i. e.* the substance in solution in the ether added to blood treated with acetic acid, is in reality iron-free hæmatin, or, as he prefers to call it, *hæmatoin*. Hæmatin also forms a special compound with a characteristic spectrum, when acted on by potassium cyanide. Hoppe-Seyler² by treating reduced hæmoglobin with acids or alkalis, in the total absence of oxygen, obtained a colouring body, with a characteristic spectrum, to which he gave the name of hæmochromogen, regarding it as the substance, forming part of hæmoglobin, which by oxidation passes into hæmatin.

In conclusion, the condition of oxygen in the blood is as follows. Of the whole quantity of oxygen in the blood, only a minute fraction is simply absorbed or dissolved, according to the law of pressures (the Henry-Dalton law). The great mass is in a state of combination with the hæmoglobin, the connection being of such a kind that while the hæmoglobin readily combines with the oxygen of the air to which it is exposed, dissociation readily occurs at low pressures, or in the presence of indifferent gases, or by the action of substances having a greater affinity for oxygen than has hæmoglobin itself. The difference between venous and arterial blood, as far as oxygen is concerned, is that while in the latter there is an insignificant quantity of reduced hæmoglobin, in the former there is a great deal; and the characteristic colours of venous and arterial blood are in the main due to the fact that the colour of reduced hæmoglobin is purple, while that of oxy-hæmoglobin is scarlet.

The relations of the Carbonic Acid in the Blood.

Of the total quantity of carbonic acid which can be extracted from blood, by far the greater part is given off to the mercurial vacuum. It is only a small portion (2 to 5 vols. per cent.) which needs the addition of an acid to drive it off. These two quantities of the gas may be distinguished by the names 'loose,' and 'fixed,' or 'stable.' Like the oxygen, the loose carbonic acid is, for the

¹ *Die Blutkrystalle* (1871), p. 181.

² *Untersuch.*, iv. (1871) 540.

most part, not simply dissolved in the blood; the absorption of it does not follow the law of pressures. The absorption of carbonic acid however is not so specially connected with the corpuscles as is that of oxygen; for serum absorbs carbonic nearly as readily as the entire blood, the quantity absorbed by equal volumes of serum alone and of blood differing very slightly. What constituent or constituents of both serum and the corpuscles thus render blood capable of absorbing so much more than simple water, is not exactly known.

It was suggested by Fernet that sodium carbonate will take up another equivalent of carbonic anhydride, and so become sodium bicarbonate, and that a solution of sodium phosphate will take up carbonic acid in the proportion of one equivalent of the acid to two of the salt, $2\text{PO}_4\text{Na}_2\text{H} + \text{CH}_2\text{O}_2 = 2\text{PO}_4\text{Na}_2\text{H}_2 + \text{CNa}_2\text{O}_2$; but in these combinations the carbonic acid requires for dissociation very low pressures, and besides, the sodium phosphate, though present in the ash, is not a constituent of natural blood, the phosphates of the ash being largely due to oxidation of the phosphorus in the lecithin of the corpuscles. It has been suggested that the carbonic acid may be associated with some of the proteid substances in the serum or corpuscles, *e.g.* the globulin; but exact knowledge on this point is wanting.

The relations of the Nitrogen in the Blood.

The small quantity of this gas which is present in both arterial and venous blood seems to exist partly in a state of simple solution, partly in some loose chemical combination, but the conditions of the association are unknown.

SEC. 4. THE RESPIRATORY CHANGES IN THE LUNGS.

The entrance of Oxygen. We have already seen that the blood in passing through the lungs takes up a certain variable quantity (from 8 to 12 p. c. vols.) of oxygen. We have further seen that the quantity so taken up, putting aside the insignificant fraction simply absorbed, enters into direct but loose combination with the hæmoglobin. We have also seen that at low pressures the oxygen is dissociated from the hæmoglobin and set free, but not at high pressures. If the tension of the oxygen in the lungs is higher than the tension of the oxygen in the venous blood of the pulmonary artery, there will be no difficulty in the reduced hæmoglobin of that blood taking up oxygen; and this may go on until the hæmoglobin of the blood in the pulmonary capillaries is all converted into oxy-hæmoglobin, or until the oxygen tension in the blood is increased so as to be equal to that of the air in the lungs. Now the oxygen in the expired air amounts to about 16 p. c., having lost 4 or 5 p. c. in the lungs. Of course the air at the bottom of the lungs will contain still less oxygen. How much less we do not exactly

know, but we may probably put the limit of reduction at 10 p. c. We may say then that the tension of the oxygen in the pulmonary air-cells is at least 10 p. c.—or, to measure it in millimetres of mercury, since the pressure of the one entire atmosphere is 760 mm., $\frac{1}{10}$ th of that will amount to 76 mm.

Now the tension of oxygen in the arterial blood of the dog¹ amounts to 3·9 p. c. (varying from 5·6 to 2·8), or about 30 mm. of mercury. That is to say, the arterial blood of the dog exposed to an atmosphere containing 3·9 p. c. of oxygen neither gives off nor takes up any oxygen. The tension of the oxygen in the average venous blood of the dog amounts to 2·9 p. c. (varying from 4·6 to 1·3)². Both these numbers are far below 10 p. c.; in fact we may suppose the percentage of oxygen in the pulmonary alveoli to be less than half the amount stated above, and yet see no difficulty in ordinary venous blood taking up oxygen while passing through the lungs. But what takes place when the tension of the oxygen in the air is lowered, as when the windpipe is obstructed, and asphyxia sets in? It has been ascertained that in the dog, in the last breath given out in such an asphyxia, the expired air has an oxygen tension of 2·3 p. c., and when the heart ceases to beat, the oxygen of the pulmonary air sinks to 4·03 p. c. These tensions are of course lower than that of ordinary venous blood, but in asphyxia the blood is no longer ordinary venous blood; instead of containing a comparatively small amount, it contains a large and gradually increasing amount, of reduced hæmoglobin. And as the reduced hæmoglobin increases in amount, the oxygen tension of the venous blood decreases; it thus keeps below that of the air in the lungs; and hence even the last traces of oxygen in the lungs are taken up by the blood, and carried away to the tissues. Even with the last heart's beat, when the oxygen in the lungs has sunk to 4·03 p. c., the bands of oxy-hæmoglobin may still for a moment be detected in the blood of the left side of the heart³.

Exit of Carbonic Acid. This presents greater difficulties. In the dog the tension of the carbonic acid in arterial blood has been estimated at 2·8 p. c.; and that of venous blood from the right side of the heart at 5·4 p. c.; that is to say, venous blood neither gives off nor takes up carbonic acid when exposed to an atmosphere containing 5·4⁴ p. c. of that gas, while it takes it up from an atmosphere containing more, and gives it off to one containing less. In order that venous blood may give up its carbonic acid to the air in the lungs, the latter must contain in the dog less than 5·4 p. c. of that gas. From Becher's result (see *antea* p. 265) it was inferred that the air in the pulmonary cells has a higher carbonic-acid ten-

¹ Strassburg. Pflüger's *Archiv*, vi. (1872) p. 65.

² In Wolfberg's experiments, see next page, the percentage of oxygen in the secluded pulmonary district, varied, at the end of an experiment, from 1·4 to 4·6.

³ Stroganow. Pflüger's *Archiv*, xii. (1876) p. 18.

⁴ Wolfberg, about 3·5, see note 2 next page.

sion than this, viz. 7.5 p. c.; hence arose the necessity of supposing that while the blood is travelling along the pulmonary capillaries, some event occurs which temporarily increases the carbonic-acid tension in the blood. Thus it was suggested that, coincident with the entrance of oxygen, hæmoglobin is in part decomposed, giving rise to an acid, which acting on stable or fixed carbonic acid, sets it free, and so increases the tension. It was also suggested that the pulmonary tissue may exercise some special action, that in fact the pulmonary epithelium is a true secreting tissue, and is able to secrete carbonic acid by an active process comparable to the secretion of gastric juice or of urine. We now however have reason to think, from the researches of Wolffberg¹, that in the dog, at a time when the mean carbonic-acid tension of the venous blood in the heart was found to be 3.43 p. c.², the limit of tension in the pulmonary air was ascertained to be 3.56 p. c., i.e. allowing for errors of observation, as nearly as possible the same; in other words, in respiration the carbonic acid passes by simple diffusion into the pulmonary air, until an equilibrium of tensions is reached between the blood and the air.

The objections to Becher's results are that he did not determine the gases of his own blood, and, moreover, by holding his breath increased the general tension of carbonic acid in his venous blood. Wolffberg inserted into a small bronchus a catheter around which was arranged a small bag which could be at will inflated so as completely to block up the bronchus. Thus without any general disturbance of breathing, he was able to stop the ingress of fresh air into a limited portion of the pulmonary tissue. After a lapse of five minutes, allowing ample time for equilibrium to be established between the air in the isolated portion of lung and the venous blood, the air was withdrawn by the catheter and analysed.

The arguments in favour of a specific action of the pulmonary epithelium are derived from the experiments of J. J. Müller³, who found that more carbonic acid was given off when blood was sent through the lungs than when simply agitated with air. The scarcity of protoplasm in the thin pulmonary epithelium opposes such a view.

In favour of the idea that the entrance of oxygen has an effect on the setting free of the carbonic acid, may be quoted the facts that the carbonic-acid tension of venous blood is found to be greater when determined by the agitation of the blood with air containing oxygen than when air free from oxygen is used, and that the carbonic-acid tension of serum is less than that of the entire blood, and is increased by the addition of blood-corpuscles. It is also asserted that the stable carbonic acid is less in arterial than in venous blood, as if during the conversion some had been set free.

It may here be noted that, according to Strassburg⁴, the carbonic-acid tension rises rapidly as coagulation sets in, reaching then as much as 8.13 p. c. This rather favours the idea that the carbonic acid is peculiarly associated with some of the forms of globulin.

¹ Pflüger's *Archiv*, iv. (1871) 465, vi (1872) 23.

² This was distinctly less than the average. Possibly what is stated above as the average is too high, the animals suffering slightly from dyspnoea when the blood was drawn.

³ Ludwig's *Arbeiten*, 1869, p. 37.

⁴ Pflüger's *Archiv*, vi. (1872) 65.

SEC. 5. THE RESPIRATORY CHANGES IN THE TISSUES.

In passing through the several tissues the arterial blood becomes once more venous. A considerable quantity of the oxy-hæmoglobin becomes reduced, and a quantity of carbonic acid passes from the tissues into the blood. The amount of change varies in the various tissues, and in the same tissue may vary at different times. Thus in a gland at rest, as we have seen, the venous blood is dark, shewing the presence of a large quantity of reduced hæmoglobin; when the gland is active, the venous blood in its colour, and in the amount of hæmoglobin which it contains, resembles closely arterial blood. The blood therefore which issues from a gland at rest is more 'venous' than that from an active gland, though the total quantity of carbonic acid formed in a given time may be greater in the latter. The blood, on the other hand, which comes from a contracting muscle, is not only richer in carbonic acid, but also, though not to a corresponding amount, poorer in oxygen than the blood which flows from a muscle at rest.

In all these cases the great question which comes up for our consideration is this: Does the oxygen pass from the blood into the tissues, and does the oxidation take place in the tissues, giving rise to carbonic acid, which passes in turn away from the tissues into the blood? or do certain oxidisable reducing substances pass from the tissues into the blood, and there become oxidized into carbonic acid and other products, so that the chief oxidation takes place in the blood itself?

There are, it is true, reducible substances in the blood, but these are small in amount, and the quantity of carbonic acid to which they give rise when the blood containing them is agitated with air or oxygen, is so small as scarcely to exceed the errors of observation.

The conclusion of Estor and St Pierre, that the oxygen diminishes even in the great arteries from the heart outwards, has been shewn by Pflüger to be based on erroneous analyses.

On the other hand, it will be remembered that in speaking of muscle, we drew attention to the fact that a frog's muscle removed from the body contained no free oxygen whatever. None could be obtained from it by the mercurial air-pump. Yet such a muscle will produce and discharge a considerable quantity of carbonic acid, not only while contracting, but also when at rest. A muscle is always producing carbonic acid, and when it contracts there is a sudden and extensive increase of the normal production. Oxygen is necessary for the life of the muscle: when venous instead of arterial blood is sent through the blood-vessels of a muscle, the irritability speedily disappears, and unless fresh oxygen be administered the muscle soon dies. It may however, during the interval in which irritability is still retained after the supply of oxygen has been cut

off, continue to contract vigorously. The presence of oxygen, though necessary for the *maintenance* of irritability, is not necessary for the *manifestation* of that irritability, is not necessary for that explosive decomposition which develops a contraction. A frog's muscle will continue to contract and to produce carbonic acid in an atmosphere of hydrogen or nitrogen, that is in the total absence of free oxygen both from itself and from the medium in which it is placed.

If from the fact that no free oxygen is present, that the tension of oxygen is nil in the muscle out of the body, we may infer that the muscle within the body does not permanently contain any quantity of free oxygen, it is evident on the one hand that this state of things is most favourable for the oxygen of the blood to pass from the blood into the muscular tissue, and on the other, that immediately the oxygen has passed, it is in some way fixed so as to be no longer removable by diminished tension. It is further evident that in the case of a muscle the carbonic acid comes direct from the muscle itself, and that the oxidation which takes place occurs in the muscle itself; the respiration of muscle does not consist in throwing oxidisable substances into the blood, there to be oxidized into carbonic acid and other matters.

Our knowledge of the respiratory changes in muscle is more complete than in the case of any other tissue; but we have no reason to suppose the phenomena of muscle are exceptional. On the contrary, all the available evidence goes to shew that in all tissues the oxidation takes place in the tissue, and not in the adjoining blood. It is a remarkable fact, that lymph, serous fluids, bile, urine, and the other secretions, contain no free or loosely combined oxygen, while the tension of carbonic acid in peritoneal fluid is as high as 6 per cent., and in bile and urine is still higher. The tension of carbonic acid in lymph, while higher than that of arterial blood, is lower than that of the general venous blood; but this probably is due to the fact that the lymph in its passage onwards is largely exposed to arterial blood in the connective tissues and in the lymphatic glands, where the production of carbonic acid is slight as compared to that going on in muscles. Strassburg¹ has attempted to determine the tension of carbonic acid in the intestinal walls; the experiment is perhaps open to objection, but the result is worth recording; he found the tension to be 7·7 per cent., *i. e.* higher than that of the femoral venous blood. All these facts point to the conclusion, that it is the tissues, and not the blood, which become primarily loaded with carbonic acid, the latter simply receiving the gas from the former by diffusion; and that the oxygen which passes from the blood into the tissues is at once taken up in some combination, so that it is no longer removable by diminished tension.

As a matter of fact, Oertmann² has shewn that if in a frog, the whole blood of the body be replaced by normal saline solution, the total meta-

¹ Pflüger's *Archiv*, vi. (1872) 65.

² Pflüger's *Archiv* xv. (1877) p. 381.

bolism of the body is, for some time, unchanged. The saline medium is able, owing to the low rate of metabolism, and large respiratory surface of the animal, to supply the tissues with all the oxygen they need, and to remove all the carbonic acid they produce. It is difficult to believe that, in such an experiment, the oxidation took place in the saline solution itself while circulating in the blood-vessels and tissue-spaces of the animal.

We may add, that the blood itself removed from the body has practically no oxidative power at all over substances which are undoubtedly oxidized in the body. If grape-sugar be added to blood, or to a solution of hæmoglobin, the mixture may be kept for a long time at the temperature of the body, without undergoing oxidation¹; and even within the body a slight excess of sugar in the blood over a certain percentage wholly escapes oxidation, and is discharged unchanged. Many easily oxidized substances, such as pyrogallic acid, pass largely through the blood of a living body without being oxidized. The organic acids, such as citric, even in combination with alkaline bases, are only partially oxidized; when administered as acids, and not as salts, they are hardly oxidized at all. It is of course quite possible that the changes which the blood undergoes when shed might interfere with its oxidative action, and hence the fact that shed blood has little or no oxidizing power, is not a satisfactory proof that the unchanged blood within the living vessels may not have such a power. But did oxidation take place largely in the blood itself, one would expect even highly diffusible substances to be oxidized in their transit; whereas if we suppose the oxidation to take place in the tissues, it becomes intelligible why such diffusible substances as those which the tissues in general refuse to take up largely, should readily pass unchanged from the blood through the secreting organs.

We have seen that in muscle the production of carbonic acid is not directly dependent on the consumption of oxygen. The muscle produces carbonic acid in an atmosphere of hydrogen. What is true of muscle is true also of other tissues and of the body at large. Spallanzani and W. Edwards shewed long ago that animals might continue to breathe out carbonic acid in an atmosphere of nitrogen or hydrogen; and recently Pflüger² has shewn, by a remarkable experiment, that a frog kept at a low temperature will live for several hours, and continue to produce carbonic acid in an atmosphere absolutely free from oxygen. The carbonic acid produced during this period was made by help of the oxygen inspired in the hours anterior to the commencement of the experiment. The oxygen then absorbed was stowed away from the hæmoglobin into the tissues, it was made use of to build up the explosive compounds, whose explosions later on gave rise to the carbonic acid; or, to adopt Pflüger's simile, the oxygen helps to wind up the vital clock; but once wound up the clock will go on for a period without further winding. The frog will continue to live, to move, to produce car-

¹ Hoppe-Seyler, *Untersuch.* i. (1866) p. 136.

² Pflüger's *Archiv*, x. (1875) 251.

bonic acid for a while without any fresh oxygen, as we know of old it will without any fresh food; it will continue to do so till the explosive compounds which the oxygen built up are exhausted; it will go on till the vital clock has run down.

To sum up, then, the results of respiration in its chemical aspects. As the blood passes through the lungs, the low oxygen tension of the venous blood permits the entrance of oxygen from the air of the pulmonary alveolus, through the thin alveolar wall, through the thin capillary sheath, through the thin layer of blood plasma, to the red corpuscle, and the reduced hæmoglobin of the venous blood becomes wholly, or all but wholly, oxy-hæmoglobin. Hurried to the tissues, the oxygen, at a *comparatively* high tension in the arterial blood, passes largely into the tissue, in which the oxygen tension is always kept at an exceedingly low pitch, by the fact that the tissue, in some way at present unknown to us, packs away at every moment into some stable combination each molecule of oxygen which it receives from the blood. With much but not all of its oxy-hæmoglobin reduced, the blood passes on as venous blood. How much hæmoglobin is reduced will depend on the activity of the tissue itself. The quantity of hæmoglobin in the blood is the measure of limit of the oxidizing power of the body at large; but within that limit the amount of oxidation is determined by the tissue, and by the tissue alone.

Though the quantity of carbonic acid expired (p. 266) may be temporarily increased by an increase of the respiratory movements, this, according to Pflüger, is to be regarded as the result of increased ventilation rather than of increased metabolic production. This physiologist¹ has brought forward strong evidence in favour of the views urged by him that neither the extent of the respiratory movements nor the velocity of the flow of blood are to be regarded as prime factors determining the amount of general metabolism. It is according to him the quicker metabolism which determines the more active circulation and the more vigorous respiration; not *vice versa*.

We cannot trace the oxygen through its sojourn in the tissue. We only know that sooner or later it comes back as carbonic acid (and other matters not now under consideration). Owing to the continual production of carbonic acid, the tension of that gas in the extravascular elements of the tissue is always higher than that of the blood; the gas accordingly passes from the tissue into the blood, and the venous blood passes on not only with its hæmoglobin reduced, but with its carbonic-acid tension increased. Arrived at the lungs, the blood finds the pulmonary air at a lower carbonic-acid tension than itself. The gas accordingly streams through the thin vascular and alveolar walls, till the tension without the blood-vessel is equal to the tension within. Thus the air of the pulmonary

¹ Pflüger's *Archiv* vi. (1872) 43; x. (1875) 251; xiv. (1877) 1. Finkler, *ibid.* x. 368. Finkler and Oertmann, *ibid.* xiv. 38.

alveoli, having given up oxygen to the blood and taken up carbonic acid from the blood, having a higher carbonic acid tension and a lower oxygen tension than the tidal air in the bronchial passages, mixes rapidly with this by diffusion. The mixture is further assisted by ascending and descending currents; and the tidal air issues from the chest at the breathing out poorer in oxygen and richer in carbonic acid than the tidal air which entered at the breathing in.

SEC. 6. THE NERVOUS MECHANISM OF RESPIRATION.

Breathing is an involuntary act. Though the diaphragm and all the other muscles employed in respiration are voluntary muscles, *i. e.* muscles which can be called into action by a direct effort of the will, and though respiration may be modified within very wide limits by the will, yet we habitually breathe without the intervention of the will: the normal breathing may continue, not only in the absence of consciousness, but even after the removal of all the parts of the brain above the medulla oblongata.

We have already seen how complicated is even a simple respiratory act. A very large number of muscles are called into play. Many of these are very far apart from each other, such as the diaphragm and the nasal muscles; yet they act in harmonious sequence in point of time. If the lower intercostal muscles contracted before the scaleni, or if the diaphragm contracted while the other chest-muscles were enjoying an interval of rest, the satisfactory entrance and exit of air would be impossible. These muscles moreover are coordinated also in respect of the amount of their several contractions; a gentle and ordinary contraction of the diaphragm is accompanied by gentle and ordinary contractions of the intercostals, and these are preceded by gentle and ordinary contractions of the scaleni. A forcible contraction of the scaleni, followed by simply a gentle contraction of the intercostals, would hinder rather than assist inspiration. Further, the whole complex inspiratory effort is followed by a less marked but still complex expiratory action. It is impossible that all these so carefully coordinated muscular contractions should be brought about in any other way than by coordinate nervous impulses descending along efferent nerves from a coordinating centre. By experiment we find this to be the case.

When in a rabbit the trunk of a phrenic nerve is cut, the diaphragm on that side remains motionless, and respiration goes on without it. When both nerves are cut, the whole diaphragm remains quiescent, though the respiration becomes excessively laboured.

The occasional slight rhythmic movements of the diaphragm observed by Brown-Séguard, after section of the phrenic, interesting from another point of view, do not militate against the above statement.

When an intercostal nerve is cut no active respiratory movement is seen in that space, and when the spinal cord is divided below the

origin of the seventh cervical spinal nerve, costal respiration ceases, though the diaphragm continues to act and that with increased vigour. When the cord is divided just below the medulla, all thoracic movements cease, but the respiratory actions of the nostrils and glottis still continue. These however disappear when the facial and recurrent laryngeal are divided. We have already stated that after removal of the brain above the medulla, respiration still continues very much as usual, the modifications which ensue from loss of the brain being unessential. Hence, putting all these facts together, it is clear that in respiration, coordinated impulses do, as we suggested, descend from the medulla along the several efferent nerves. The proof is completed by the fact that the removal or injury of the medulla alone at once stops all respiratory movements, even though every muscle and every nerve concerned be left intact. Nay more, if only a small portion of the medulla, a tract whose limits are not as yet exactly fixed, but which lies below the vasomotor centre¹, between it and the calamus scriptorius, be removed or injured, respiration ceases for ever, though every other part of the body be left intact. When this spot is excised or injured, breathing at once ceases, and since the inhibitory vagus centre is generally at the same time stimulated, and the heart's beat arrested, death ensues instantaneously. Hence this portion of the nervous system was called by Flourens the vital knot, or ganglion of life, *nœud vital*. We shall speak of it as the respiratory centre. The nature of this centre must be exceedingly complex; for while even in ordinary respiration it gives rise to a whole group of coordinate nervous impulses of inspiration followed in due sequence by a smaller but still coordinate group of expiratory impulses, in laboured respiration fresh and larger impulses are generated, though still in coordination with the normal ones, the expiratory events being especially augmented; and in the more extreme cases of dyspnoea and asphyxia impulses overflow, so to speak, from it in all directions, though only gradually losing their coordination, until almost every muscle in the body is thrown into contractions.

The first question we have to consider is, Are we to regard the rhythmic action of this respiratory centre as due essentially to changes taking place in itself, or as due to afferent nervous impulses or other stimuli which affect it in a rhythmic manner from without? In other words, Is the action of the centre automatic or purely reflex? We know that the centre may be influenced by impulses proceeding from without, and that the breathing may be affected by the action of the will, or by an emotion, or by a dash of cold water on the skin, or in a hundred other ways; but the fact that the action of the centre may be thus modified from without, is no proof that the continuance of its activity is dependent on extrinsic causes.

In attempting to decide this question we naturally turn to the pneumogastric as being the nerve most likely to serve as the channel

¹ See *antea*, p. 158.

of afferent impulses setting in action the respiratory centre. If both vagi be divided, respiration still continues though in a modified form. This proves distinctly that afferent impulses ascending those nerves are not the efficient cause of the respiratory movements. We have seen that when the spinal cord is divided below the medulla, the facial and laryngeal movements still continue. This proves that the respiratory centre is still in action, though its activity is unable to manifest itself in any thoracic movement. But when the cord is thus divided the respiratory centre is cut off from all sensory impulses, save those which may pass into it from the cranial nerves; and the division of these cranial nerves in no way destroys respiration. Hence it is clear that the respiratory impulses proceeding from the respiratory centre are not simply afferent impulses reaching the centre along afferent nerves and transformed by reflex action in that centre. They evidently start *de novo* from the centre itself, however much their characters may be affected by afferent impulses reaching that centre at the time of their being generated. The action of the centre is automatic, not simply reflex.

Among the afferent impulses which affect the automatic action of the centre, the most important are those which ascend along the vagi. If one vagus be divided, the respiration becomes slower; if both be divided, it becomes very slow, the pauses between expiration and inspiration being excessively prolonged. The character of the respiratory movement too is markedly changed, each respiration is fuller and deeper, so much so that what is lost in rate is gained in extent, the amount of carbonic acid produced and oxygen consumed in a given period remaining after division of the nerves about the same as when they were intact. It is evident from this, in the first place, that during life afferent impulses are continually ascending the vagi and modifying the action of the respiratory centre, and in the second place, that the modification bears simply on the distribution in time of the efferent respiratory impulses, and not at all on the amount to which they are generated. These afferent impulses are probably started in the lungs by the condition of the blood in the pulmonary capillaries acting as a stimulus to the peripheral endings of the nerves, though possibly the altered air in the air-cells may also act as a stimulus on the nerve-endings.

It has been suggested that the mere movements of expansion and contraction may also serve as a stimulus. According to Hering and Breuer¹, when air is mechanically driven into the chest, an expiratory movement follows, and when air is drawn out, an inspiratory; and this not only with atmospheric air but with indifferent gases, such as nitrogen; when both vagi are cut, these effects do not appear. They infer from this, that the mere mechanical expansion of the lungs transmits along the vagus an impulse tending to inhibit inspiration and to generate an expiration, and the mechanical contraction of the lung an impulse tending to inhibit

¹ *Wien Sitzungsbericht*. Nov. 5, 1868.

expiration and to generate an inspiration. Hence according to them the very expansion of the lungs, which is the natural effect of an inspiration, tends of itself to cut short that inspiration and to inaugurate the sequent expiration, and similarly the contraction of an expiration promotes the following inspiration. They speak in fact of the lungs as being so far self-regulating. This view, however, though very interesting can perhaps hardly at present be regarded as proved¹.

When the central stump of one of the divided vagi is stimulated with a gentle interrupted current, the respiration, which from the division of the nerves had become slow, is quickened again; and with care, by a proper application of the stimulus, the normal respiratory rhythm may for a time be restored. Upon the cessation of the stimulus, the slower rhythm returns. If the current be increased in strength, the rhythm may in some cases be so accelerated that at last the diaphragm is brought into a condition of prolonged tetanus, and a standstill of respiration in an extreme inspiratory phase is the result.

If the central end of the superior laryngeal branch of the vagus be stimulated, whether the main trunk of the nerve be severed or not, a slowing of the respiration takes place, and this may by proper stimulation be carried so far that a complete standstill of respiration in the phase of rest is brought about, *i.e.* the respiratory apparatus remains in the condition which obtains at the close of an ordinary expiration, the diaphragm being completely relaxed. In other words, the superior laryngeal nerve contains fibres, the stimulation of which produces afferent impulses whose effect is to inhibit the action of the respiratory centre; while the main trunk of the vagus contains fibres, the stimulation of which produces afferent impulses whose effect is to accelerate or augment the action of the respiratory centre. In some cases stimulation of the main trunk of the vagus also causes a slowing or even standstill of the respiration, especially when the nerve has become exhausted by previous stimulation. We may explain these results by supposing that while the superior laryngeal contains only inhibitory fibres, the main trunk of the vagus contains both accelerating and inhibitory fibres, the former however greatly preponderating. While, from the results of simple section of the main trunk, it is clear that the accelerating fibres are continually at work, it is not so clear that the inhibitory fibres are always in action, since section even of both superior laryngeals does not necessarily quicken respiration.

The statement made above, if not wholly satisfactory, has at least the merit of reconciling conflicting statements. For a long time a controversy was carried on between those authors who maintained that stimulation of the central end of the vagus, when the nerve was divided in the neck, brought about a tetanic contraction of the diaphragm and so had an inspiratory effect, and those who observed a complete relaxation to follow

¹ Guttman, Du Bois-Reymond's *Archiv*, 1875, p. 500.

upon stimulation and so regarded the effect as expiratory. We are indebted to Rosenthal¹ for pointing out the contrast between the action of the main trunk of the vagus and that of the superior laryngeal branch; and the view just put forward in the text is in the main that of Rosenthal, except so far as the existence of any inhibitory fibres at all in the main trunk is concerned. We further owe to Rosenthal a consistent theory of the manner in which the vagus acts on the respiratory centre. According to him we may regard the respiratory centre as the seat of two conflicting forces, one tending to generate respiratory impulses, and the other offering resistance to the generation of these impulses, the one and the other alternately gaining the victory and thus leading to a rhythmic discharge. The afferent impulses passing upward along the main trunks of the vagi are further to be looked upon as acting not on the generation of impulses but on the resistance offered by the centre, diminishing that resistance in proportion to their intensity. Hence when the vagi are divided, the central resistance is increased, owing to the absence of the diminishing effect of the usual afferent impulses, and in consequence, the respiratory impulses take a longer time in gathering head sufficient to overcome the increased resistance and therefore are less frequent, though the discharge when it does occur is proportionately more forcible. Stimulation of the divided vagi on the other hand by increasing the afferent impulses and so diminishing the central resistance renders the discharges more frequent. The impulses which ascend to the medulla along the superior laryngeal branches may in like manner be regarded as increasing the central resistance, and thus as inhibitory of the respiratory discharge.

It is obvious that this theory, though constructed chiefly with the view of explaining inspiratory impulses and their inhibition, must, in order to be satisfactory, also include the consideration of distinctly expiratory impulses. For in laboured respiration we must in some way or other admit the existence of specific expiratory impulses, and if Hering and Breuer's view be correct, the vagus must even in ordinary breathing be the channel of stimuli which excite expiratory impulses. Rosenthal regards the expiratory regions of the respiratory centre as being less irritable and requiring a stronger stimulus than the inspiratory regions, and therefore brought into play to any extent only when the blood is less arterial than usual.

Stimulation of the central end of the inferior laryngeal is said to have an inhibitory effect like that of the superior laryngeal, but much slighter².

This double or alternate respiratory action of the vagi may be taken as in a general way illustrative of the manner in which other afferent nerves and various parts of the cerebrum are enabled to influence respiration, this or that afferent impulse, started by a stimulus applied to the skin or elsewhere, or by an emotion and the like, playing, according to circumstances, now an inhibitory now an accelerating part. As we know from daily experience, of all the psychical nervous centres, the respiratory centre is the one which

¹ *Die Athembewegungen*, 1862, and Du Bois-Reymond's *Archiv*, 1864, p. 456; 1865, p. 191; 1870, p. 423.

² Rosenthal, *Automat. Nerven-Centra*, 1875.

is most frequently and most deeply affected by nervous impulses from various quarters.

The one thing, however, which above others affects the respiratory centre, is the condition of the blood in respect to its respiratory changes; the more venous (less arterial) the blood, the greater is the activity of the respiratory centre. When by reason either of any hindrance to the entrance of air into the chest, or of a greater respiratory activity of the tissues, as during muscular exertion, the blood becomes less arterial, more venous, *i.e.* with a smaller charge of oxyhæmoglobin and more heavily laden with carbonic acid, the respiration from being normal becomes laboured. This effect of deficient arterialization of blood is very different from that of section of the vagi; it is no mere change in the distribution of impulses; the breathing is quicker as well as deeper, there is an increase of the sum of efferent impulses proceeding from the centre, and the expiratory impulses, which in normal respiration are very slight, acquire a pronounced importance. As the blood becomes, in cases of obstruction, less and less arterial, more and more venous, the discharge from the respiratory centre becomes more and more vehement, and instead of confining itself to the usual tracts, and passing down to the ordinary respiratory muscles, overflows into other tracts, puts into action other muscles, until there is perhaps hardly a muscle in the body which is not made to feel its effects. And this discharge may, as we shall see in speaking of asphyxia, continue till the nervous energy of the respiratory centre is completely exhausted. The effect of venous blood then is to augment these natural explosive decompositions of the nerve-cells of the respiratory centre which give rise to respiratory impulses; it increases their amount, and also quickens their rhythm. The latter change however is always much less marked than the former, the respiration in dyspnœa being much more deepened than hurried, and the several respiratory acts are never so much hastened as to catch each other up, and so to produce an inspiratory tetanus like that resulting from stimulation of the vagus. On the contrary, especially as exhaustion begins to set in, the rhythm becomes slower out of proportion to the weakening of the individual movements.

There seem to be two distinct kinds of dyspnœa. In one with increased depth the rhythm is not proportionately quickened or may even be diminished. Thus in the dyspnœa caused by section of the plirœnic nerves, the rhythm falls notably¹. In the other, which may be called the asthmatic type, the rhythm is hurried, while the depth of each breath is not increased but, in many cases at least, diminished.

On the other hand, the blood may be made not more but less venous than usual. This condition may be brought about by an animal being made to inspire oxygen, or to breathe for a time more rapidly and more forcibly than the needs of the economy require.

¹ Purkinje, quoted by Hering and Breuer, *Op. cit.*

If in a rabbit artificial respiration is carried on very vigorously for a while, and then suddenly stopped, the animal does not immediately begin to breathe. For a variable period no respiration takes place at all, and when it does begin occurs gently and normally, only passing into dyspnœa if the animal is unable to breathe of itself, and then quite gradually. Evidently during this period the respiratory centre is in a state of complete rest, no explosions are taking place, no respiratory impulses are being generated, and the quiet transition from this condition to that of normal respiration shews that the subsequent generation of impulses is attended by no great disturbance. The cause of this state of things, which is known as that of *apnœa*, is to be sought for in the condition of the blood. By the increased vigour of the artificial respiratory movements the hæmoglobin of the arterial blood, which is naturally not quite saturated, becomes almost completely so, and the dissolved oxygen is increased, its tension being largely augmented. Respiration is arrested because the blood is more highly arterialized than usual. Thus we have in *apnœa* the converse to dyspnœa; and both states point to the same conclusion, that the activity of the respiratory centre is dependent on the condition of the blood, being augmented when the blood is less arterial and more venous, being depressed when it is more arterial and less venous than usual.

The question now arises, Does this condition of the blood affect the respiratory centre directly, or does it produce its effect by stimulating the peripheral ends of afferent nerves in various parts of the body, and, by the creation there of afferent impulses, indirectly modify the action of the centre? Without denying the possibility that the latter mode of action may help in the matter, as regards not only the vagi, but all afferent nerves, it is clear from the following reasons that the main effect is produced by the direct action of the blood on the respiratory centre itself. If the spinal cord be divided below the medulla oblongata, and both vagi be cut, want of proper aeration of the blood still produces an increased activity of the respiratory centre, as shewn by the increased vigour of the facial respiratory movements. If the supply of blood be cut off from the medulla by ligature of the blood-vessels of the neck, dyspnœa is produced, though the operation produces no change in the blood generally, but simply affects the respiratory condition of the medulla itself, by cutting off its blood-supply, the immediate result of which is an accumulation of carbonic acid and a paucity of available oxygen in the protoplasm of the nerve-cells in that region. If the blood in the carotid artery in an animal be warmed above the normal, dyspnœa is at once produced. The over-warm blood hurries on the activity of the nerve-cells of the respiratory centre, so that the normal supply of blood is insufficient for their needs. The condition of the blood then affects respiration by acting directly on the respiratory centre itself.

Deficient aeration produces two effects in blood: it diminishes the

oxygen, and increases the carbonic acid. Do both of these changes affect the respiratory centre, or only one, and if so, which? When an animal is made to breathe an atmosphere containing nitrogen only, the exit of carbonic acid by diffusion is not prevented, and the blood contains no excess of carbonic acid¹. Yet all the phenomena of dyspnoea are present. In this case these can only be attributed to the deficiency of oxygen. On the other hand, if an animal be made to breathe an atmosphere rich in carbonic acid, but at the same time containing abundance of oxygen, true dyspnoea does not occur. The animal suffers from symptoms similar to those caused by the poisons known as narcotic. It becomes sleepy, drowsy, and finally unconscious, but though the respiration is modified, actual dyspnoea and asphyxia are not produced. The carbonic acid acts on some portions of the cerebrum, but has no specific respiratory action on the respiratory centre. These facts leave no doubt that the action of deficiently arterialized blood on the respiratory centre, as manifested in an augmentation of the respiratory explosions, is due primarily to a want of oxygen, and not to an excess of carbonic acid.

SEC. 7. THE EFFECTS OF RESPIRATION ON THE CIRCULATION.

We have seen, while treating of the circulation, that the blood-pressure curves are marked by undulations, which, since their rhythm is synchronous with that of the respiratory movements, are evidently in some way connected with respiration. When the brain of a living mammal is exposed by the removal of the skull, a rhythmical rise and fall of the cerebral mass, a pulsation of the brain, is observed; and upon examination it will be found that these pulsations are synchronous with the respiratory movements, the brain rising up during expiration and sinking during inspiration. They disappear when the arteries going to the brain are ligatured, or when the venous sinuses of the dura mater are laid open so as to admit of a free escape of the venous blood. They evidently arise from the expiratory movements in some way hindering and the inspiratory movements assisting the return of blood from the brain. We have already (p. 106) stated that during inspiration the pressure of blood in the great veins may become negative, *i.e.* sink below the pressure of the atmosphere; and a puncture of one of these veins may cause immediate death by air being actually drawn into the vein and thus into the heart during an inspiratory movement. When the veins of an animal are laid bare in the neck and watched, the so-called *pulsus venosus* may be observed in them, that is, they swell up during expiration and diminish again during inspiration. And indeed a little consideration will shew that the expansion and contraction of the chest must have a decided effect on the flow of blood through the

¹ Pflüger, *Pflüger's Archiv*, i. (1868) p. 61.

thoracic portion and thus indirectly through the whole of the vascular system.

The heart and great blood-vessels are, like the lungs, placed in the air-tight thoracic cavity, and are subject like the lungs to the pumping action of the respiratory movements. Were the lungs entirely absent from the chest, the whole force of the expansion of the thorax in inspiration would be directed to drawing blood from the extra-thoracic vessels towards the heart, and conversely the effect of the contraction of the thorax in expiration would be to drive the blood back again from the heart towards the extra-thoracic vessels. In the presence of the lungs however the free entrance of air into the interior of the chest tends to maintain the pressure around the heart and great vessels within the thorax equal to the ordinary atmospheric pressure on the vessels of the rest of the body outside the thorax; but it is unable completely to equalize the two pressures. Did the air enter as freely into the lungs as it does into the pleural cavities when wide openings are made in thoracic walls, the respiratory movements would have very little effect indeed on the flow of blood to and from the heart, just as under similar circumstances (p. 255) they would be ineffectual in promoting the entrance and exit of air to and from the lungs. But the air does *not* pass into the pulmonary alveoli as freely as it would do into a pleural cavity through an opening in the thoracic wall. Before the inspired air can fill a pulmonary alveolus, the walls of the alveolus have to be distended *at the expense of the pressure which causes the inspired air to enter*. Part of the atmospheric pressure in fact which causes the entrance of the air into the lung is spent in overcoming the elasticity of the pulmonary passages and cells. Consequently, any structure lying within the thorax but outside the lungs, is never, even at the conclusion of an inspiration when the lungs are filled with air, subject to a pressure as great as that of the atmosphere. The pressure on such a structure always falls short of the pressure of the atmosphere by the amount of pressure necessary to counterbalance the elasticity of the pulmonary passages and cells. And, since the fraction of the atmospheric pressure which is thus spent in distending the lungs increases as the lungs become more and more stretched, it follows that the fuller the inspiration the greater is the difference between the pressure on structures outside the lungs but within the thorax and the ordinary pressure of the atmosphere. Now we have seen (p. 255) that the pressure necessary to counterbalance the elasticity of the lungs, when they are completely at rest (in the pause between expiration and inspiration), is in man about 5 to 7 mm. of mercury, and that when the lungs are fully distended, as at the end of a forcible inspiration, the pressure rises to as much as 30 mm. of mercury. Hence at the height of a forcible inspiration the pressure exerted on the heart and great vessels within the thorax is 30 mm. less than the ordinary atmospheric pressure of 760 mm., and even when the chest is completely at rest,

at the end of an expiration, the pressure on the heart and great vessels is slightly (by about 5 mm. mercury) below that of the atmosphere.

During an inspiration then the pressure around the heart and great blood-vessels becomes considerably less than that of the atmosphere on the vessels outside the thorax. During expiration this pressure returns towards that of the atmosphere, but in ordinary breathing never quite reaches it. It is only in forcible expiration that the pressure on the thoracic vascular organs exceeds that of the atmosphere. But if during inspiration the pressure bearing on the right auricle and the venæ cavæ becomes less than the pressure which is bearing on the jugular, subclavian, and other veins, outside the thorax, this must result in an increased flow from the latter into the former. Hence, during each inspiration a larger quantity of blood enters the right side of the heart. This probably leads to a stronger stroke of the heart, and at all events causes a larger quantity to be ejected by the right ventricle; this causes a larger quantity to escape from the left ventricle, and thus more blood is thrown into the aorta, and the arterial tension proportionately increased. During expiration the converse takes place. The pressure on the intra-thoracic blood-vessels returns to the normal, the flow of blood from the veins outside the thorax into the venæ cavæ and right auricle is no longer assisted, and in consequence less blood passes through the heart into the aorta, and arterial tension falls again. During forced expiration, the intra-thoracic pressure may be so great as to afford a distinct obstacle to the flow from the veins into the heart.

The effect of the respiratory movements on the arteries is naturally different from that on the veins. During inspiration, the aortic arch, from the diminution of pressure outside it, tends to expand; in consequence the pressure of blood within it, *i. e.* the arterial tension, tends to diminish. During expiration, the increase of pressure outside the aortic arch of course tends to increase also the blood-pressure within it, acting in fact just in the same way as if the coats of the aorta themselves contracted. Thus the effects of the respiratory movements on the great veins and great arteries respectively, are, as far as arterial blood-pressure is concerned, antagonistic to each other; the effect on the veins being to increase arterial tension during inspiration and to diminish it during expiration, while the effect on the arteries is to diminish arterial tension during inspiration and to increase it during expiration. But we should naturally expect the effect on the thin-walled veins to be greater than that on the stout thick-walled arteries, so that the total effect of inspiration would be to increase, and the total effect of expiration to diminish, arterial tension.

These facts seem at first sight to afford a ready explanation of the respiratory undulations of the blood-pressure curve; the rise of pressure in each undulation might be supposed to be due to the

inspiratory, the fall to the expiratory movement. When however the respiratory undulations of the blood-pressure curve are compared carefully with the variations of intra-thoracic pressure, it is seen that neither the rise nor the fall of the former are exactly synchronous with either diminution or increase of the latter. Fig. 42

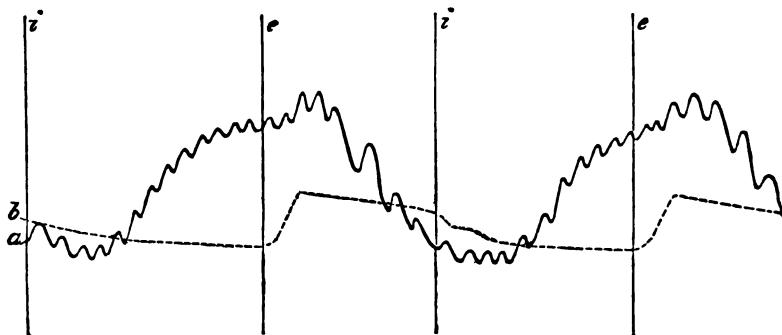

FIG. 42. COMPARISON OF BLOOD-PRESSURE CURVE WITH CURVE OF INTRA-THORACIC PRESSURE. To be read from left to right.

a is the blood-pressure curve, with its respiratory undulations, the slower beats on the descent being very marked. *b* is the curve of intra-thoracic pressure obtained by connecting one limb of a manometer with the pleural cavity. Inspiration begins at *i*, expiration at *e*. The intra-thoracic pressure rises very rapidly after the cessation of the inspiratory effort, and then slowly falls as the air issues from the chest; at the beginning of the inspiratory effort the fall becomes more rapid.

shews two tracings from a dog taken at the same time, one, *a*, being the ordinary blood-pressure curve from the carotid, and the other, *b*, representing the condition of the intra-thoracic pressure, as obtained by carefully bringing a manometer into connection with the pleural cavity. On comparing the two curves, it is evident that neither the maximum nor the minimum of arterial pressure coincides exactly either with inspiration or with expiration. At the beginning of inspiration (*i*) the arterial pressure is seen to be falling; it soon however begins to rise, but does not reach the maximum until some time after expiration (*e*) has begun; the fall continues during the remainder of expiration, and passes on into the succeeding inspiration. In order to reconcile the facts represented by these curves with the mechanical explanation given above, we must suppose that the beneficial effects of the inspiratory movement in the larger supply of blood brought to the heart, take some time to develop themselves, and last beyond the movement itself.

But there are phenomena which shew that the respiratory undulation is more complex in its causation than would at first sight appear; that other influences besides simply mechanical ones are at work. One striking feature of the respiratory undulation in the blood-pressure curve of the dog is the fact that the pulse-rate is

quicken during the rise of the undulation and becomes slower during the fall. The quickening of the beat might be considered as itself partly accounting for the rise, were it not for two facts. In the rabbit, the respiratory undulations, though well marked, present a very small difference of pulse-rate in the rise and fall. In the dog, the difference is at once done away with, without any other essential change in the undulations, by section of both vagi. Evidently the slower pulse during the fall is caused by a coincident stimulation of the cardio-inhibitory centre in the medulla oblongata, the quicker pulse during the rise being due to the fact that, during that interval, the centre is comparatively at rest. We have here most important indications that, while the respiratory centre in the medulla oblongata is at work, sending out rhythmic impulses of inspiration and expiration, the neighbouring cardio-inhibitory centre is, as it were by sympathy, thrown into an activity of such a kind that its influence over the heart waxes and wanes with each respiratory movement.

But if the cardio-inhibitory centre is thus synchronously affected, ought we not to expect that the vaso-motor centre should also be involved in the action? We have very clear evidence that it is. When, in an animal under urari, artificial is substituted for natural respiration, undulations of the blood-pressure curve are observed (Fig. 43, 1) similar in character to, though less in extent than, those seen under natural conditions. Now in artificial respiration, the mechanical conditions, under which the thoracic viscera are placed as regards pressure, are the exact opposite of those existing during natural respiration; for the pressure within the chest is increased instead of diminished, when air is blown into the trachea to distend the lungs. Evidently the respiratory undulations of blood-pressure which occur during artificial respiration cannot be explained on the same mechanical grounds.

Moreover, similar undulations are witnessed in the absence of all respiratory movements, and are also seen when the chest is opened, the heart removed, and an artificial circulation of blood kept up by means of a mechanical pump. In this case they cannot be at all connected with events going on in the chest; they must be dependent on variations in the peripheral resistance of the vascular system.

When artificial respiration is stopped, a very large but steady rise of pressure is observed. This may be in part due to the increased force of the cardiac beat, caused by the increasingly venous character of the blood; but only in part, and that a small part. The rise so witnessed is very similar to that brought about by powerfully stimulating a number of vaso-constrictor nerves; and there can be no doubt that it is due to the venous blood stimulating the vaso-motor centre in the medulla, and thus causing constriction of the small arteries of the body. We say 'stimulating the vaso-motor centre,' because, though possibly the venous blood may act directly on local peripheral mechanisms, or on the muscular coats of the small arteries them-

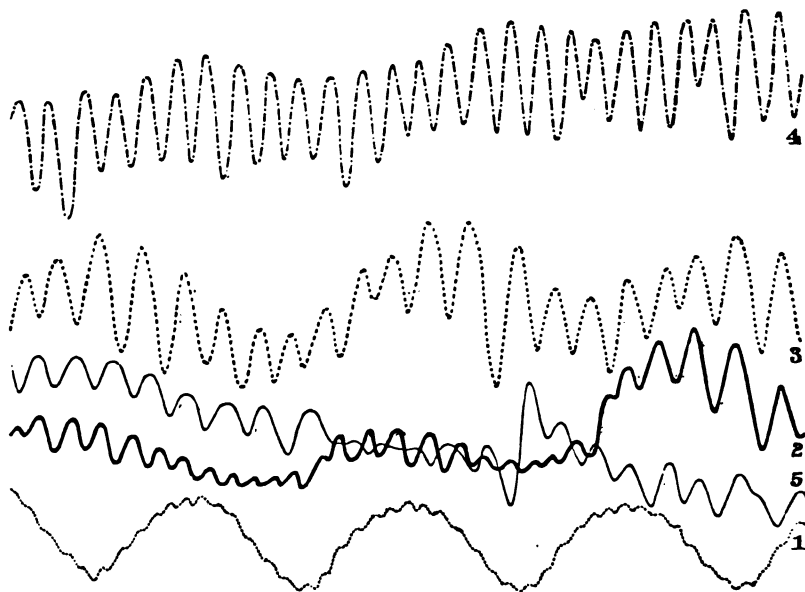

FIG. 43. TRAUBE'S CURVES. To be read from left to right.

The curves 1, 2, 3, 4, 5, were taken at intervals, and all form part of one experiment. Each curve is placed in its proper position relative to the base line, which, to save space, is omitted. During 1, artificial respiration was kept up, the undulations visible are therefore not due to the mechanical action of the chest. When the artificial respiration was suspended these undulations for a while disappeared, and the blood-pressure rose steadily while the heart-beats became slower. Soon, as shewn in curve 2, the undulations re-appeared. A little later, the blood-pressure was still rising, the heart-beats still slower, but the undulations still obvious (curve 3). Still later (curve 4), the pressure was still higher, but the heart-beats were quicker, and the undulations flatter. The pressure then began to fall rapidly (curve 5), and continued to fall until some time after artificial respiration was resumed.

selves, the fact that the rise of pressure under these circumstances is a very slight one when the spinal cord has been previously divided below the medulla, shews that it is the centre itself which plays the chief part. Similarly, section of the spinal cord, it is said, obliterates or largely diminishes the undulations seen in artificial respiration. Moreover, though when artificial respiration is suddenly stopped, the respiratory undulations cease also, the blood-pressure curve rising steadily in almost a straight line; yet after a while new undulations, the so-called Traube's curves, make their appearance (Fig. 43, 2, 3), very similar to the previous ones, except that their curves are larger and of a more sweeping character. These new undulations—which, since they appear in the absence of all thoracic movements, passive or active, and are witnessed even when both vagi are cut, must be of vaso-motorial origin—are maintained as long as the blood-pressure continues to rise. With the increasing venosity of the blood,

however, both the vaso-motor centre and the heart become exhausted; the undulations disappear, and the blood-pressure rapidly sinks. Relying on the obvious nature of these curves of Traube, we are led to the view that the rhythmic undulations seen in artificial respiration are due to a rhythmic stimulation of the vaso-motor centre, a stimulation which is dependent for its amount on the venous character of the blood circulating through the medulla oblongata. And if this is the case with artificial respiration, we may infer that a similar rhythmic stimulation of the vaso-motor centre is in part at least the cause of the undulations seen during natural breathing. Hence the peculiar features of these undulations may be considered as due partly to the mechanical conditions of the flow of blood through the thorax, and partly to a rhythmic stimulation both of the vaso-motor centre and of the cardio-inhibitory centre, synchronous as far as the mere repetition of the rhythm is concerned with the stimulation of the respiratory centre itself.

Funke and Latschenberger¹ have brought forward the ingenious suggestion that the mere expansion and collapse of the lungs, whether brought about by thoracic aspirations as in natural, or by tracheal pressure as in artificial respiration, by affecting the capacity of the pulmonary capillaries, modifies the flow through the lungs from the right to the left side of the heart, and so produces variations in arterial pressure. They argue that the act of expansion of the lungs, by stretching and thus narrowing the pulmonary capillaries, forces an extra quantity of blood from the capillaries into the left side of the heart and so increases the pressure in the aorta; and conversely in the expiratory collapse of the pulmonary alveoli, the capillaries in regaining their normal width are able for the time being to hold in themselves a larger quantity of blood, and so to reduce the flow into the left auricle and to diminish temporarily the arterial pressure. It follows of course that the permanent condition of expansion is (with narrow capillaries) unfavourable, and that of expiration (with wider capillaries) favourable to the flow of blood from the right to the left side of the heart, so that the immediate results of each kind of movement are in time followed by effects of an opposite kind. And the authors, by help of these views, offer very ingenious explanations of the variations in blood-pressure which accompany variations in the rhythm and character of the respiratory movements. But further experiments and criticism are necessary before their theory can be accepted, as they propose, as a substitute for the vaso-motor theory, or even as demonstrating the presence of a third factor in the production of the undulations.

It may be remarked that in the development of Traube's curves the vaso-motor centre manifests a rhythm of its own. The action of the stimulus, viz. of the venous blood, is constant, yet the activity of the centre rises and falls in periods determined by itself: in other words, the vaso-motor centre, like so many other centres, is capable of manifesting a rhythmic automatism. Since however in natural respiration the rhythm of the vaso-motor centre is synchronous with that of the respiratory centre (though the maximum of activity does not fall exactly at the same time in each),

¹ Pflüger's *Archiv*, xv. (1877) 405.

we must suppose that the latter is able by irradiation or in some other way to regulate the rhythm of the former, and thus to bring it into harmony with itself.

It has been suggested that the increased frequency of beat during the inspiratory phase may be due to the mechanical distension of the lungs, whereby afferent impulses are transmitted along the vagus, which by inhibiting the cardio-inhibitory centre cause an increased frequency of beat. But the experiments on which this view is based are not conclusive.

SEC. 8. THE EFFECTS OF CHANGES IN THE AIR BREATHED.

The Effects of deficient Air. Asphyxia.

When, on account of occlusion of the trachea, or by breathing in a confined space, a due supply of air is not obtained, normal respiration gives place through an intermediate phase of dyspnœa to the condition known as asphyxia; this, unless remedial measures be taken, rapidly proves fatal.

Phenomena of Asphyxia. As soon as the oxygen in the arterial blood sinks below the normal, the respiratory movements become deeper and at the same time more frequent; both the inspiratory and expiratory phases are exaggerated, the supplementary muscles spoken of at p. 262 are brought into play, and the rate of the rhythm is hurried. In this respect, dyspnœa, or hyperpnœa as this first stage has been called, contrasts very strongly with the peculiar respiratory condition caused by section of the vagi, in which the respiratory movements, while much more profound than the normal, are diminished in frequency.

As the blood continues to become more and more venous the respiratory movements continue to increase both in force and frequency, a larger number of muscles being called into action and that to an increasing extent. Very soon, however, it may be observed that the expiratory movements are becoming more marked than the inspiratory. Every muscle which can in any way assist in expiration is in turn brought into play; and at last almost all the muscles of the body are involved in the struggle. The orderly expiratory movements culminate in expiratory convulsions, the order and sequence of which is obscured by their violence and extent. That these convulsions, through which dyspnœa merges into asphyxia, are due to a stimulation of the medulla oblongata by the venous blood, is proved by the fact that they fail to make their appearance when the spinal cord has been previously divided below the medulla, though they still occur after those portions of the brain which lie above the medulla have been removed. It is usual to speak of a 'convulsive centre' in the medulla, the stimulation of which gives rise to these convulsions; but if we accept the existence of such a centre we must

at the same time admit that it is connected by the closest ties with the normal expiratory division of the respiratory centre, since every intervening step may be observed between a simple slight expiratory movement of normal respiration and the most violent convulsion of asphyxia. An additional proof that these convulsions are carried out by the agency of the medulla is afforded by the fact that convulsions of a wholly similar character are witnessed when the supply of blood to the medulla is suddenly cut off by ligaturing the blood-vessels of the head. In this case the nervous centres, being no longer furnished with fresh blood, become rapidly asphyxiated through lack of oxygen, and expiratory convulsions quite similar to those of ordinary asphyxia, and preceded like them by a passing phase of dyspnoea, make their appearance. Similar 'anæmic' convulsions are seen after a sudden and large loss of blood from the body at large, the medulla being similarly stimulated by lack of arterial blood.

Such violent efforts speedily exhaust the nervous system; and the convulsions after being maintained for a brief period suddenly cease and are followed by a period of calm. The calm is one of exhaustion; the pupils, dilated to the utmost, are unaffected by light; touching the cornea calls forth no movement of the eyelids, and indeed no reflex actions can anywhere be produced by the stimulation of sentient surfaces. All expiratory active movements have ceased; the muscles of the body are flaccid and quiet; and though from time to time the respiratory centre gathers sufficient energy to develop respiratory movements, these resemble those of quiet normal breathing, in being, as far as muscular actions are concerned, almost entirely inspiratory. They occur at long intervals, like those after the section of the vagi; and like them are deep and slow. The exhausted respiratory centre takes some time to develop an inspiratory explosion; but the impulse when it is generated is proportionately strong. It seems as if the resistance which had in each case to be overcome was considerable, and the effort in consequence, when successful, productive of a large effect.

As time goes on, these inspiratory efforts become less frequent; their rhythm becomes irregular; long pauses, each one of which seems a final one, are succeeded by several somewhat rapidly repeated inspirations. The pauses become longer, and the inspiratory movements shallower. Each inspiration is accompanied by the contraction of accessory muscles, especially of the face, so that each breath becomes more and more a prolonged gasp. The inspiratory gasps spread into a convulsive stretching of the whole body; and with extended limbs, and a straightened trunk, with the head thrown back, the mouth widely open, the face drawn, and the nostrils dilated, the last breath is taken in.

Thus we are able to distinguish three stages in the phenomena which result from a continued deficiency of air:—(1) A stage of dyspnoea, characterized by an increase of the respiratory movements

both of inspiration and expiration. (2) A convulsive stage, characterized by the dominance of the expiratory efforts, and culminating in general convulsions. (3) A stage of exhaustion, in which lingering and long-drawn inspirations gradually die out. When brought about by sudden occlusion of the trachea these events run through their course in about 4 or 5 minutes in the dog, and in about 3 or 4 minutes in the rabbit. The first stage passes gradually into the second, convulsions appearing at the end of the first minute. The transition from the second stage into the third is somewhat abrupt, the convulsions suddenly ceasing early in the second minute. The remaining time is occupied in the third stage.

The duration of asphyxia varies not only in different animals but in the same animal under different circumstances. Newly born and young animals need much longer immersion in water before death by asphyxia occurs than do adults. Thus while in a full-grown dog recovery from drowning is unusual after $1\frac{1}{2}$ minutes, a new-born puppy has been known to bear an immersion of as much as 50 minutes. The cause of the difference lies in the fact that in the young animal the respiratory changes of the tissues are much less active. These consume less oxygen, and the general store of oxygen in the blood has a less rapid demand made upon it. The respiratory activity of the tissues may also be lessened by a deficiency in the circulation; hence bodies in a state of syncope at the time when the deprivation of oxygen begins can endure the loss for a much longer period than can bodies in which the circulation is in full swing. There being the same store of oxygen in the blood in each case, the quicker circulation must of necessity bring about the speedier exhaustion of the store. In many cases of drowning, death is hastened by the entrance of water into the lungs.

By training, the respiratory centre may be accustomed to bear a scanty supply of oxygen for a much longer time than usual before dyspnoea sets in, as is seen in the case of divers.

The phenomena of slow asphyxia, where the supply of air is gradually diminished, are fundamentally the same as those resulting from a sudden and total deprivation. The same stages are seen, but their development takes place more slowly.

The circulation in Asphyxia. If the carotid or other artery of an animal be connected with a manometer during the development of the asphyxia just described, the following facts may be observed. During the first and second stages the blood-pressure rises rapidly, attaining a height far above the normal. During the third stage it falls even more rapidly, repassing the normal and becoming *nil* as death ensues. The respiratory undulations of the pressure-curve are abrupt and somewhat irregular, the inspiratory movements being accompanied by a fall of pressure. When the animal has been previously placed under urari, so that the respiratory impulses cannot manifest themselves by any muscular movements, the rise of the pressure curve, as we have already said, is at first steady and unbroken, but after a variable period Traube's curves make their

appearance. As during the third stage the pressure sinks, these undulations pass away.

The heart-beats are at first somewhat quickened, but speedily become slow, while at the same time they acquire great force; so that the pulse-curves on the tracing are exceedingly bold and striking, Fig. 43. Even while the blood-pressure is sinking, the pulse-curves still maintain somewhat these characters; and the heart continues to beat for some seconds after the respiratory movements have ceased, the strokes at last rapidly failing in frequency and strength.

If the chest of an animal be opened under artificial respiration, and asphyxia brought on by cessation of the respiration, it will be seen that the heart during the second and third stages becomes completely gorged with venous blood, all the cavities as well as the large veins being distended to the utmost. If the heart be watched to the close of the events, it will be seen that the feebler strokes which come on towards the end of the third stage are quite unable to empty its cavities; and when the last beat has passed away its parts are still choked with blood. The veins spirt out when pricked: and it may frequently be observed that the beats recommence when the over-distension of the heart's cavities is relieved by puncture of the great vessels. When rigor mortis sets in after death by asphyxia, the left side of the heart is more or less emptied of its contents; but not so the right side. Hence in an ordinary post-mortem examination in cases of death by asphyxia, while the left side is found comparatively empty, the right appears gorged.

These various phenomena are probably brought about in the following way.

The increasingly venous character of the blood augments the action of the general vaso-motor centre, and thus leads to a general constriction of the small arteries. This is the cause of the markedly increased blood-pressure; though, as we have already said, possibly the venous blood may also act directly on the peripheral vaso-motor mechanism or on the muscular arterial coats, or may even affect the peripheral resistance by modifying the changes in the capillary regions, see p. 173.

This increased peripheral resistance, while indirectly (p. 150) helping to augment the force of the heart's beat, is a direct obstacle to the heart emptying itself of its contents. On the other hand, the increased respiratory movements favour the flow of venous blood towards the heart, which in consequence becomes more and more full. This repletion is moreover assisted by the marked infrequency of the beats. This in turn depends in part on the cardio-inhibitory centre in the medulla being stimulated by the venous blood; since when the vagi are divided the infrequency is much less pronounced. It does not however disappear altogether; and we are therefore driven to suppose it is in part due to the venous blood acting in an inhibitory manner directly on the heart itself. The increased resistance in front, the augmented supply from behind, and the long pauses

between the strokes, all concur in distending the heart more and more.

When the large veins have become full of blood the inspiratory movements can no longer have their usual effect in increasing the blood-pressure. The whole force of the chest movement, as far as the circulation is concerned, is spent in diminishing the pressure around the large arteries; and hence the sinking of the blood-pressure during each inspiratory movement.

The distension of the cardiac cavities, at first favourable to the heart-beat, as it increases becomes injurious. At the same time the cardiac tissues, which at first probably are stimulated, after a while become exhausted by the action of the venous blood; and the strokes of the heart become feebler as well as slower.

On account of this increasing slowness and feebleness of the heart's beat, the blood-pressure, in spite of the continued arterial constriction, begins to fall, since less and less blood is pumped into the arterial system; the boldness of the pulse-curves at this stage being chiefly due to the infrequency of the strokes. As the quantity which passes from the heart into the arteries becomes less second by second, the pressure gets lower and lower, the descent being assisted by the exhaustion of the vaso-motor centre, until almost before the last beats it has sunk to zero. Thus at the close of asphyxia, while the heart and venous system are distended with blood, the arterial system is less than normally full.

The Effects of an increased supply of Air. Apnœa.

It is a matter of common experience that after several inspiratory efforts of greater force than ordinary, the breath can be held for a much longer time than usual. In other words, by an increased respiratory action, the blood can be brought into such a condition that the generation of the respiratory impulses in the medulla is delayed beyond the usual time; the desire to breathe can then be resisted for a longer time than usual. This state of things, which we can easily produce in ourselves, is the beginning of that peculiar condition brought about by a too vigorous respiration, or by the inhalation of oxygen, to which we have already (p. 293) referred under the name of 'apnœa'. The essential feature of apnœa consists in the blood containing for the time being more oxygen than usual. In consequence of this a longer time is needed before the deficiency of oxygen in the blood of the capillaries of the medulla oblongata, or rather in the nerve-cells constituting the respiratory centre, reaches the limit which determines the discharge of a respiratory impulse. The molecular processes of these cells are so arranged, that whenever the oxygen which is available for their

¹ It is to be regretted that this name is used by some medical authorities in a sense almost identical with asphyxia. In its physiological sense, as here used, it is the very opposite of asphyxia.

use sinks below a certain level, respiratory explosions occur whereby a fresh supply of oxygen is gained. By increasing their available oxygen, the explosive action of the cells is deferred and diminished; that is, apnœa is established. Similarly when the supply of oxygen is diminished, the explosions are hastened and increased, that is, dyspnœa is brought about. The different conditions of the respiratory centre during apnœa, normal breathing or eupnœa, and dyspnœa, are well shewn by the different effects produced by stimulating the afferent fibres of the trunk of the vagus with the same stimulus during the three stages. If the current chosen be of such a strength as will gently increase the rhythm of normal breathing, it will be found to have no effect at all in apnœa, while in dyspnœa it may produce almost convulsive movements. Indeed in well-marked apnœa, even strong stimulation of the vagus may produce no effect whatever.

According to Ewald¹ the hæmoglobin of the blood during apnœa becomes perfectly or almost perfectly saturated with oxygen. The absolute increase does not seem great, from '1 to '9 p. c. vol. The tension at which this increment exists is however very great. The venous blood, if the artificial respiration, used to produce the apnœa, be carefully carried out, contains more oxygen than the normal and appears of a bright red colour. In cases where the artificial respiration interferes with the pulmonary circulation and so reduces the rapidity of the general flow of blood, the venous blood may be even darker than usual².

The Effects of changes in the Composition of the Air breathed.

Deficiency of Oxygen. This we have already seen (p. 294) is the true cause of dyspnœa and of asphyxia.

Excess of Oxygen. This, except in the cases which we shall consider immediately, produces apnœa.

Excess or deficiency of Nitrogen. Variations in amount of nitrogen have, *per se*, no effect at all. The gas is eminently an indifferent gas as far as physiological processes are concerned.

Excess of Carbonic Acid. When an animal is made to breathe an atmosphere containing an excess of carbonic acid in the presence of an ample supply of oxygen, the breathing becomes laboured, the respiratory movements being deeper and more frequent. True dyspnœa however does not set in, and death does not take place by convulsions and asphyxia; the symptoms on the contrary resemble those of an animal under the influence of a narcotic poison such as opium.

Poisonous gases. Carbonic oxide produces the same effects as deficiency of oxygen, inasmuch as it preoccupies the hæmoglobin

¹ Pflüger's *Archiv*, vii. (1873) 575.

² Finkler and Oertmann. Pflüger's *Archiv*, xiv. (1877) 38.

and so prevents the blood from becoming properly oxygenated, see p. 277. Sulphuretted hydrogen produces similar effects, but in a different manner; it acts as a reducing agent, see p. 274. Some gases are irrespirable, on account of their causing spasm of the glottis, and this is said to be, to a certain extent, the case with carbonic acid.

The Effects of changes in the Pressure of the Air breathed¹.

Gradual Diminution of Pressure. The symptoms are those of deficiency of oxygen; the animals die of asphyxia. The blood contains less and less oxygen as the pressure is reduced, the quantity present in the arterial blood soon becoming less than that in normal venous blood. The quantity of carbonic acid in the blood is also diminished. The increasing dyspnoea is accompanied by great general feebleness; and convulsions though frequent are not invariable. The occurrence of these seems to depend on the suddenness with which the oxygen of the blood is diminished.

Sudden Diminution. Death in these cases ensues from the liberation of gases within the blood-vessels and the consequent mechanical interference with the circulation. The gas which is found in the blood-vessels on examination after death consists chiefly of nitrogen.

Increase of Pressure. Up to a pressure of several atmospheres of air, merely symptoms of narcotic poisoning, altogether like those of breathing an excess of carbonic acid, are developed, and there can be little doubt that they originate from the same cause, viz. the excess of carbonic acid in the blood. At a pressure however of 4 atmospheres of oxygen, corresponding to 20 atmospheres of air, and upwards, a very remarkable phenomenon presents itself. The animals die of asphyxia and convulsions, exactly in the same way as when oxygen is deficient. Corresponding with this it is found that the production of carbonic acid is diminished. That is to say, when the pressure of the oxygen is increased beyond a certain limit, the oxidations of the body are diminished, and with a still further increase of the oxygen are arrested altogether. The oxidation of phosphorus is quite analogous; at a high pressure of oxygen phosphorus will not burn. Bert has further shewn that plants, bacteria, and organized ferments, are similarly killed by a too great pressure of oxygen.

SEC. 9. MODIFIED RESPIRATORY MOVEMENTS.

The respiratory mechanism with its adjuncts, in addition to its respiratory function, becomes of service, especially in the case of man, as a means of expressing emotions. The respiratory column of air, moreover, in its exit from the chest, is frequently made use of in a

¹ Paul Bert, *Rech. Exp. sur la Pression Baromet.* 1874.

mechanical way to expel bodies from the upper air-passages. Hence arise a number of peculiarly modified and more or less complicated respiratory movements, sighing, coughing, laughter, &c. adapted to secure special ends which are not distinctly respiratory. They are all essentially reflex in character, the stimulus determining each movement, sometimes affecting a peripheral afferent nerve as in the case of coughing, sometimes working through the higher parts of the brain as in laughter and crying, sometimes possibly, as in yawning and sighing, acting on the respiratory centre itself. Like the simple respiratory act, they may with more or less success be carried out by a direct effort of the will.

Sighing is a deep and long-drawn inspiration chiefly through the nose followed by a somewhat shorter, but correspondingly large expiration.

Yawning is similarly a deep inspiration, deeper and longer continued than a sigh, drawn through the widely open mouth, and accompanied by a peculiar depression of the lower jaw and frequently by an elevation of the shoulders.

Hiccough consists in a sudden inspiratory contraction of the diaphragm, in the course of which the glottis suddenly closes, so that the further entrance of air into the chest is prevented, while the impulse of the column of air just entering, as it strikes upon the closed glottis, gives rise to a well-known accompanying sound. The afferent impulses of the reflex act are conveyed by the gastric branches of the vagus. The closure of the glottis is carried out by means of the inferior laryngeal nerve. See *Voice*.

In **sobbing** a series of similar convulsive inspirations follow each other slowly, the glottis being closed earlier than in the case of hiccough, so that little or no air enters into the chest.

Coughing consists in the first place of a deep and long-drawn inspiration by which the lungs are well filled with air. This is followed by a complete closure of the glottis, and then comes a sudden and forcible expiration, in the midst of which the glottis suddenly opens, and thus a blast of air is driven through the upper respiratory passages. The afferent impulses of this reflex act are in most cases, as when a foreign body is lodged in the larynx or by the side of the epiglottis, conveyed by the superior laryngeal nerve; but the movement may arise from stimuli applied to other afferent branches of the vagus, such as those supplying the bronchial passages and stomach (?) and the auricular branch distributed to the meatus externus. Stimulation of other nerves also, such as those of the skin by a draught of cold air, may develop a cough.

In **sneezing** the general movement is essentially the same, except that the opening from the pharynx into the mouth is closed by the contraction of the anterior pillars of the fauces and the descent of

the soft palate, so that the force of the blast is driven entirely through the nose. The afferent impulses here usually come from the nasal branches of the fifth. When sneezing however is produced by a bright light, the optic nerve would seem to be the afferent nerve.

Laughing consists essentially in an inspiration succeeded, not by one, but by a whole series, often long continued, of short spasmodic expirations, the glottis being freely open during the whole time, and the vocal chords being thrown into characteristic vibrations.

In **crying**, the respiratory movements are modified in the same way as in laughing; the rhythm and the accompanying facial expressions are however different, though laughing and crying frequently become indistinguishable.

Our real knowledge of the physiology of respiration dates back from 1777, when Lavoisier shewed the true nature of combustion, following close as this did upon Priestley's demonstration of the identity of respiration and combustion (1771) and discovery of oxygen (1774). Before that time the chief steps of progress were, the discovery by Van Helmont (1648) that gas sylvestre (carbonic acid gas) was unfit for respiration, the demonstration by Hook (1664) of the effects of artificial respiration, by Lower (1669) of the connection with respiration of the difference in colour between venous and arterial blood, by Boyle (1670) of the necessity for respiratory purposes of the air dissolved in water, the observations and reflections of Mayow (1674) on the spiritus nitro-aereus (oxygen), in which he narrowly missed anticipating Lavoisier by a century, and the discovery by Black (1757) of carbonic acid in air. Lavoisier however held that the respiratory combustion took place in the bronchial tubes, a hydro-carbonous substance being secreted for that purpose from the blood; and though Lagrange suggested that the oxygen might be absorbed into and the carbonic acid exhaled from the blood, the combustion occurring in the blood or tissues, and Spallanzani (1803) and W. F. Edwards (1823) shewed that snails, frogs and young mammals continued to produce carbonic acid in an atmosphere of hydrogen, whereby direct combustion in the lungs was rendered impossible, Lavoisier's view held its ground, owing to the difficulty of extracting gases from the blood, until in 1837 Magnus used the mercurial air-pump and proved that both venous and arterial blood contained both oxygen and carbonic acid. His researches and those of Lothar Meyer and Fernet, which followed soon after, form the basis of our present knowledge. The labours of Ludwig and his school, of Pflüger and his pupils, and of others, have advanced this subject to its present condition. The spectroscopic discoveries of Hoppe-Seyler and Stokes have proved of great and increasing importance; and we are indebted to Rosenthal for a clear exposition of the nervous mechanism of respiration.

CHAPTER III.

SECRETION BY THE SKIN.

WE have traced the food from the alimentary canal into the blood, and, did the state of our knowledge permit, the natural course of our study would be to trace the food from the blood into the tissues, and then to follow the products of the activity of the tissues back into the blood and so out of the body. This however we cannot as yet satisfactorily do; and it will be more convenient to study first the final products of the metabolism of the body, and the manner in which they are eliminated, and afterwards to return to the discussion of the intervening steps.

Our food consists of certain food-stuffs, viz. proteids, fats and carbohydrates, of various salts, and of water. In their passage through the blood and tissues of the body, the proteids are converted into urea (or some closely allied body), carbonic acid and water, while the fats and carbohydrates give rise to carbonic acid and water only. Many of the proteids contain phosphorus and sulphur, and some of the fats taken as food contain phosphorus; these elements suffer oxidation into phosphates and sulphates, and then leave the body in the form of salts.

Broadly speaking then, the waste products of the animal economy are urea, carbonic acid, salts and water. Of these a large portion of the carbonic acid, and a considerable quantity of water, leave the body by the lungs in respiration; while all (or nearly all) the urea, the greater portion of the salts, and a large amount of water, with an insignificant quantity of carbonic acid, pass away by the kidneys. The work therefore of the remaining excretory tissue, the skin, is confined to the elimination of a comparatively small quantity of salts, a little carbonic acid, and a variable but on the whole large quantity of water in the form of perspiration. The actual excretion by the bowel, that is to say, that portion of the fæces which is not simply undigested matter, we have seen to be very small.

The nature and amount of Perspiration.

The quantity of matter which leaves the human body by way of the skin is very considerable. Thus Sequin¹ estimated that, while

¹ *Ann. d. Chim.* xc. pp. 52, 403.

7 grains passed away through the lungs per minute, as much as 11 grains escaped through the skin. The amount varies extremely; Funke¹ calculated, from data gained by enclosing the arm in a caoutchouc bag, that the total amount of perspiration from the whole body in 24 hours might range from 2 to 20 kilos; but such a mode of calculation is obviously open to many sources of error.

Of the whole amount thus discharged, part passes away at once as watery vapour containing volatile matters, while part may remain for a time as a fluid on the skin; the former is frequently spoken of as *insensible*, the latter as *sensible* perspiration. The proportion of the insensible to the sensible perspiration will depend on the rapidity of the secretion in reference to the dryness, temperature, and amount of movement, of the surrounding atmosphere. Thus, supposing the rate of secretion to remain constant, the drier and hotter the air, and more rapidly the strata of air in contact with the body are renewed, the greater is the amount of sensible perspiration which is by evaporation converted into the insensible condition; and conversely when the air is cool, moist, and stagnant, a large amount of the total perspiration may remain on the skin as sensible sweat. Since, as the name implies, we are ourselves aware of the sensible perspiration only, it may and frequently does happen that we seem to ourselves to be perspiring largely, when in reality it is not so much the total perspiration which is being increased as the relative proportion of the sensible perspiration. The rate of secretion may however be so much increased, that no amount of dryness, or heat, or movement of the atmosphere, is sufficient to carry out the necessary evaporation, and thus the sensible perspiration may become abundant in a hot dry air. And practically this is the usual occurrence, since certainly a high temperature conduces, as we shall point out presently, to an increase of the secretion, and it is possible that mere dryness of the air has a similar effect.

The total amount of perspiration is affected not only by the condition of the atmosphere, but also by the nature and quantity of food eaten, by the amount of fluid drunk, and by the amount of exercise taken. It is also influenced by mental conditions, by medicines and poisons, by diseases, and by the relative activity of the other excreting organs, more particularly of the kidney.

The fluid perspiration, or sweat, when collected, is found to be a clear colourless fluid, with a strong and distinctive odour varying according to the part of the body from which it is taken. Besides accidental epidermic scales, it contains no structural elements. Its reaction is generally acid, but in cases of excessive secretion may become alkaline. The average amount of solids is about 1.81 p. c.², of which about two-thirds consist of organic substances. The chief normal constituents are: (1) Sodium chloride with small quantities of other inorganic salts. (2) Various acids of the fatty series, such as

¹ Moleschott's *Untersuch.* iv. p. 36.

² Funke, *Op. cit.*

formic, acetic, butyric, with probably propionic, caproic, and caprylic. The presence of these latter is inferred from the odour; it is probable that many various volatile acids are present in small quantities. Lactic acid, which Berzelius reckoned as a normal constituent, is stated not to be present in health. (3) Neutral fats, and cholesterin; these have been detected even in places, such as the palms of the hand, where sebaceous glands are absent. (4) Ammonia (urea) and possibly other nitrogenous bodies.

Funke¹ detected a very considerable amount of urea in the sweat gained by his method, so much so that he calculated the total amount given off by the skin in 24 hours at about 10 grms. Ranke² on the other hand, who collected some of the sweat given off when the body was exposed in a large space to an abundant atmosphere, found no evidence whatever of urea. This striking contradiction has not yet been explained, though, as will be seen in dealing with nutrition, the satisfactory results which are gained by supposing that under normal conditions all the urea passes out by the kidneys, render it probable that Funke's result is essentially an abnormal one. In various forms of disease the sweat has been found to contain, sometimes in considerable quantities, blood (in bloody sweat), albumin, urea (particularly in cholera), uric acid, calcium oxalate, sugar, lactic acid, indigo, bile and other pigments. Iodine and potassium iodide, succinic, tartaric, and benzoic (partly as hippuric) acids have been found in the sweat when taken internally as medicines.

Cutaneous Respiration.

A frog, the lungs of which have been removed, will continue to live for some time; and during that period will continue not only to produce carbonic acid, but also to consume oxygen. In other words, the frog is able to breathe without lungs, respiration being carried on efficiently by means of the skin. In mammals and in man this cutaneous respiration is, by reason of the thickness of the epidermis, restricted to within very narrow limits; nevertheless, when the body remains for some time in a closed chamber to which the air passing in and out of the lungs has no access (as when the body is enclosed in a large air-tight bag fitting tightly round the neck, or where a tube in the trachea carries air to and from the lungs of an animal placed in an air-tight box), it is found that the air in the chamber loses oxygen and gains carbonic acid. The amount of carbonic acid which is thus thrown off by the skin of an average man in 24 hours amounts according to Scharling to no more than about 10 grms., according to Aubert³ to about 4 grms., increasing with a rise of temperature, and being very markedly augmented by bodily exercise. Regnault and Reiset state that the amount of oxygen consumed is about equal in volume to that of carbonic acid given off, but Gerlach⁴

¹ *Op. cit.*

² *Tetanus*, p. 247.

³ *Pflüger's Archiv*, vi. (1872) 539.

⁴ *Müller's Archiv*, 1851, p. 431.

makes it rather less. It is evident therefore that the loss which the body suffers through the skin consists chiefly of water.

The thickness of the mammalian or human epidermis must afford a great obstruction to any diffusion between the blood in the cutaneous capillaries and the external air. It has been suggested that the carbonic acid makes its exit in the form of carbonates present in the sweat, and that these being decomposed by the acids also present in sweat, their carbonic acid is set free.

When an animal, such as a rabbit, is covered over with an impermeable varnish such as gelatine, so that all exit or entrance of gases or liquids by the skin is prevented, death shortly ensues. This result cannot be due, as was once thought, to arrest of cutaneous respiration, seeing how insignificant is the gaseous interchange by the skin as compared with that by the lungs. Nor are the symptoms those of asphyxia, but rather of some kind of poisoning, marked by a very great fall of temperature, which however does not seem to be the result of diminished production of heat, since according to Burdon Sanderson it is coincident with an actual increase of the discharge of heat from the surface. The animal may be restored, or at all events its life may be prolonged with abatement of the symptoms, if the great loss of heat which is evidently taking place be prevented by covering the body thickly with cotton wool, or keeping it in a warm atmosphere. The symptoms have not as yet been clearly analysed, but they seem to be due in part to a pyrexia possibly caused by the retention within or reabsorption into the blood of some of the constituents of the sweat, or by the products of some abnormal metabolism, and in part to a dilation of the cutaneous vessels which causes an abnormally large radiation of heat, even through the varnish.

According to Röhrig¹ the injunction of fresh filtered human sweat into the veins of a rabbit causes pyrexia, and albuminuria, and thus reproduces some of the effects of 'varnishing.'

The Secretion of Sweat.

The skin contains, besides the ordinary sudoriparous glands, the sebaceous glands, and the special odoriferous glands of the axilla, anus, and other regions. With regard to the various volatile and odoriferous substances peculiar to sweat, and especially with regard to those peculiar to the sweat of particular regions of the skin, there can be no doubt that these are secreted by the epithelium of the appropriate glands. There can be equally no doubt that the fats which come to the surface of the skin from the sebaceous glands arise from a metabolism of the cells of those glands. But it is a question, and at present an open question, whether the sweat as a whole is furnished by the various glands alone, or whether any considerable

¹ *Jahrb. f. Baln.* i. 1.

part of it may not simply transude through the portions of skin intervening between the mouths of the glands. That some amount of water must pass through the ordinary epidermis seems evident; but on the whole it is probable that the portion which so passes is a small fraction only of the total quantity secreted by the skin; and Erismann¹ finds that even the simple evaporation of water is much greater through those parts of the skin in which the glands are abundant than through those in which they are scanty.

The nervous mechanism of Perspiration. The secreting activity of the skin, like that of other glands, is accompanied and at least aided by vascular dilation. In one of Bernard's early experiments on division of the cervical sympathetic, it was observed that in the case of the horse, the vascular dilation of the face on the side operated on was accompanied by increased perspiration. Indeed the connection between the state of the cutaneous blood-vessels and the amount of perspiration is a matter of daily observation. When the vessels of the skin are contracted, the secretion of the skin is diminished; when they are dilated it becomes abundant. And in this way, as we shall later on point out, the temperature of the body is largely regulated. When the surrounding atmosphere is warm, the cutaneous vessels are dilated, the amount of sweat secreted is increased, and the consequently augmented evaporation tends to cool down the body. On the other hand, when the atmosphere is cold, the cutaneous vessels are constricted, perspiration is scanty, and less heat is lost to the body by evaporation.

The analogy with the other secreting organs which we have already studied renders it extremely probable that there are special nerves directly governing the activity of the sudoriparous glands, independent of variations in the vascular supply. Many pathological facts point in this direction. The profuse perspiration of the death agony, of various crises of disease, and of certain mental emotions, the cold sweats occurring in phthisis and other maladies, in all of which the skin is anæmic rather than hyperæmic, suggest direct nervous action. Moreover, we have direct experimental evidence that in the cat and dog profuse perspiration may take place in the ball of the foot as the result of stimulation of the sciatic nerve after clamping the aorta or crural artery, or immediately after amputation of the leg²; in these cases, which are quite analogous to the experiments on the submaxillary gland, the increased secretion cannot be due to hyperæmia. The analogy with the submaxillary gland is carried out still further by the fact that (in the cat at least) atropin prevents stimulation of the sciatic nerve from causing an increase of perspiration in the ball of the foot, though the vascular dilation takes place as usual³. When the sciatic nerve on one side has been

¹ *Zeitschrift f. Biol.* xi. 1.

² Kendal and Luchsinger, *Pflüger's Archiv*, XIII. (1876) 212.

³ Luchsinger, *ibid.* XIV. (1877) 369.

divided, the leg on that side frequently does not perspire under circumstances which induce perspiration in the rest of the body. In cases of injury to spinal nerves, wholly similar phenomena have been observed; and atropin has been used very successfully as a remedy for profuse perspiration. The cases where perspiration may easily be induced on one side of the face by the introduction of pungent substances into the mouth illustrates the manner in which this nervous influence over the sudoriparous glands may be brought about by reflex action. The whole subject however requires to be more fully worked out.

Luchsinger¹ has been led by his experiments to believe that (in the cat) the perspiratory activity of the lower limbs is dependent on a perspiratory centre, situated in the lower dorsal and upper lumbar spinal cord, and analogous with a vaso-motor centre. The efferent impulses from this centre pass through the communicating branches of the last two or three dorsal and first four lumbar spinal nerves, to the abdominal sympathetic, and thence to the sciatic nerve.

Absorption by the Skin.

Although under normal circumstances, the skin serves only as a channel of loss to the body, there are facts which seem to shew that it may, under particular circumstances, be a means of gain. Cases are on record where bodies have been ascertained to have gained in weight by immersion in a bath, or by exposure to a moist atmosphere during a given period, in which no food or drink was taken, or to have gained more than the weight of the food or drink taken. The gain in such cases must have been due to the absorption of water. It is doubtful whether substances in aqueous solution can be absorbed by the skin when the epidermis is intact, the evidence on this point being contradictory; but absorption takes place very readily from abraded surfaces, and even solid particles rubbed into the sound skin may, especially when applied in a fatty vehicle, as *e.g.* in the well-known mercury-ointment, find their way into the underlying lymphatics.

¹ *Op. cit.*

CHAPTER IV.

SECRETION BY THE KIDNEYS.

THE epithelium of the kidney, like that of the alimentary canal, is a secreting tissue. The protoplasmic cells which line at least a large portion of the *tubuli uriniferi* elaborate from the blood, in a manner which we shall presently discuss, certain substances, and discharge them into the channels of the tubules. Besides these distinctly active secreting structures, however, the kidney exhibits in its Malpighian bodies an arrangement very analogous to that which obtains in the lungs. Just as in the latter the functions of the alveolar epithelium are reduced to a minimum, and the entrance and egress of the gases of respiration are mainly carried on by diffusion, so in the former the epithelium covering the glomeruli can have but little secreting activity, and the passage of material from the interior of the convoluted blood-vessels into the cavities of the tubules must be chiefly a matter of simple filtration. What substances pass in this way, and what substances are secreted by the direct action of the epithelium of the secreting tubules, we shall shortly consider. The various substances passing in either the one or the other way, in company with a large amount of water, into the ducts of the gland, constitute the secretion called urine. And since none of the substances so thrown out are of any further use in the economy, but are at once carried away, urine is generally spoken of as an excretion.

SEC. 1. COMPOSITION OF URINE.

The healthy urine of man is a clear yellowish fluorescent fluid, of a peculiar odour, saline taste, and acid reaction, having a mean specific gravity of 1.020, and generally holding in suspension a little mucus. The normal constituents may be arranged in several classes.

1. Water.

2. **Inorganic salts.** These for the most part exist in urine in natural solution, the composition of the ash almost exactly corresponding with the results of the direct analysis of the fluid; in this respect urine contrasts forcibly with blood, the ash of which is largely composed of inorganic substances, which previous to

the combustion existed in peculiar combination with proteid and other complex bodies. In the ash of urine there is rather more sulphur than corresponds to the sulphuric acid directly determined; this indicates the existence in urine of some sulphur-holding complex body. And there are traces of iron, pointing to some similar iron-holding substance. But otherwise, all the substances found in the ash exist as salts in the natural fluid. The most abundant and important is sodium chloride. There are found in smaller quantities, calcium chloride, potassium and sodium sulphates, sodium, calcium and magnesium phosphates, with traces of silicates. Alkaline carbonates are frequently found, and nitrates in small quantity are also said to be sometimes present.

The phosphates are derived partly from the phosphates taken as such in food, partly from the phosphates peculiarly associated with the proteids, and partly from the phosphorus of lecithin and its allies. When urine becomes alkaline, the calcic and magnesian phosphates are precipitated, the sodium phosphates remaining in solution. The sulphates are derived partly from the sulphates taken as such in food and partly from the sulphur of the proteids. The carbonates, when occurring in large quantity, generally have their origin in the oxidation of such salts as citrates, tartrates, &c. The bases present depend largely on the nature of the food taken. Thus with a vegetable diet, the excess of the alkalis in the food reappears in the urine; with an animal diet, the earthy bases in a similar way come to the front.

3. Nitrogenous crystalline bodies, derivatives of the metabolism of the proteids of the body and food. First and foremost come urea and its immediate ally, uric acid. These will be considered in detail hereafter; they are the typical products of the metabolism of proteids. Existing in much smaller quantities are a number of bodies more or less closely related to urea, which may for the most part be regarded as less-completely oxidised products of metabolism. Such are: kreatinin, xanthin, hypoxanthin, and occasionally allantoin. To these may be added hippuric acid, ammonium oxalurate, and, at times, taurin, cystin, leucin, and tyrosin. These too we shall have to consider in dealing with the metabolism of the body.

4. Non-nitrogenous bodies. These exist in very small quantities, and many of them are probably of uncertain occurrence. They are organic acids, such as lactic, succinic, formic, oxalic, phenylic, &c. It has been maintained that minute quantities of sugar are invariably present in even healthy urine; this however has not as yet been placed beyond all doubt.

5. Pigments. These are at present very imperfectly understood. Whether the natural yellow colour of urine be due to a single pigment, the *urochrome* of Thudichum, or to more than one,

and what is the exact nature of these pigments, must be left undecided. As was stated above (p. 30), the urine frequently contains *urobilin*; and the peculiar red colour of some rheumatic urines is due to the presence of a body called by Prout *purpurin* and by Heller *uroerythrin*. The urine of man and of many animals, especially of the dog, contains *indican*, which under certain circumstances may give rise to the production of indigo-blue.

6. **Other bodies.** Urine treated with many times its volume of alcohol gives a precipitate. In this precipitate is found a body, giving proteid reactions; and an aqueous solution of the precipitate is both amylolytic and proteolytic, *i.e.* appears to contain some of both the salivary (pancreatic) ferment and pepsin.

7. **Gases.** Those gases which can be extracted from urine by the mercurial pump are chiefly nitrogen and carbonic acid, oxygen occurring in very small quantities or being wholly absent.

The quantities in which these multifarious constituents are present vary within very wide limits, being dependent on the nature of the food taken, and on the circumstances of the body. These points will be considered in the succeeding chapter. What may be called the average composition of human urine is shewn in the following table.

AMOUNTS OF THE SEVERAL URINARY CONSTITUENTS PASSED IN TWENTY-FOUR HOURS. (AFTER PARKES).

	By an average man of 66 kilos.	Per 1 kilo of Body Weight.
Water	1500·000 grammes	23·0000 grammes
Total Solids	72·000	1·100
Urea	33·180	·5000
Uric Acid	·555	·0084
Hippuric Acid	·400	·0060
Kreatinin	·910	·0140
Pigment, and other substances	10·000	·1510
Sulphuric Acid	2·012	·0305
Phosphoric Acid	3·164	·0480
Chlorine	7·000 (8·21)	·1260
Ammonia	·770	
Potassium	2·500	
Sodium	11·090	
Calcium	·260	
Magnesium	·207	

Acidity of Urine. The healthy urine of man is acid, the amount of acidity being about equivalent to 2 grms. of oxalic acid in twenty-four hours. It is due to the presence of acid sodium phosphate, the absence of free acid being shewn by the fact that

sodium hyposulphite gives no precipitate. The amount of acidity varies much during the twenty-four hours, being in an inverse ratio to the amount of acid secreted by the stomach; thus it decreases after food is taken, and increases as gastric digestion becomes complete. It varies with the nature of the food; with a vegetable diet the excess of alkalis secreted leads to alkalinity, or at least to diminished acidity, whereas this effect is wanting with an animal diet, in which the earthy bases preponderate. Hence the urine of carnivora is generally very acid, while that of herbivora is alkaline. The latter, when fasting, are for the time being carnivorous, living entirely on their own bodies, and hence their urine becomes under these circumstances acid.

The natural acidity increases for some time after the urine has been discharged, owing to the formation of fresh acid, apparently by some kind of fermentation. This increase of acid frequently causes a precipitation of urates, which the previous acidity has been insufficient to throw down. After a while however the acid reaction gives way to alkalinity. This is caused by a conversion of the urea into ammonium carbonate through the agency of a specific ferment. This ferment as a general rule does not make its appearance except in urine exposed to the air; it is only in unhealthy conditions that the fermentation takes place within the bladder.

Abnormal constituents of Urine. The structural elements found in the urine under various circumstances are blood, pus and mucus corpuscles, epithelium from the bladder and kidney, and spermatozoa. Serum-albumin, fibrin (frequently as 'casts'), alkali-albumin, globulin, a peculiar form of albumin, (discovered by Bence-Jones in *mollities ossium*, characterised by being soluble at high temperatures, and re-discovered by Kühne as a product of digestion), fats, cholesterin, sugar, leucin, tyrosin, oxalic acid, bile acids and bile pigment, may be enumerated as the most important metabolic products abnormally present in urine. Besides these the urine serves as the chief channel of elimination for various bodies, not proper constituents of food, which may happen to have been taken into the system. Thus various minerals, alkaloids, salts, pigmentary and odoriferous matters, may be passed unchanged. Many substances thus occasionally taken suffer changes in passing through the body; the most important of these will be considered in a succeeding chapter.

SEC. 2. THE SECRETION OF URINE.

We have already called attention to the fact that the kidney, unlike the other secreting organs which we have hitherto studied, consists of two distinct parts: of an actively secreting part, the epithelium of the secreting tubules, and of what may be called a

filtering part, the Malpighian bodies. Corresponding to this double structure we find that, of the various urinary constituents enumerated in the preceding section, some, such as sodium chloride, are known to be present in the blood, independently of any activity of the kidney, while of others, such as urea, it is probable that their occurrence in the blood is in part the result of some previous renal action, or at least it is not certain that this is not the case. The former we may fairly suppose to be simply filtered through the renal glomeruli; the latter we may regard provisionally as the products of the activity of the renal epithelium. Since the passage of fluids and dissolved substances through membranes is in large part directly dependent on pressure, the extent and rapidity of that part of the whole process of the secretion of urine which is a mere filtration, will be directly affected by the amount of arterial pressure in the renal arteries, while the effect of variations of arterial pressure on that part of the process which is a real active secretion, will be an indirect one only. Since, then, the discharge of urine by the kidneys must be in large measure a mere matter of pressure, much more so than is the case with the secretion of saliva or of gastric juice, it will be more convenient to study the relations of urinary secretion to blood-pressure before we enter upon the discussion of the active secretion itself.

The relation of the Secretion of Urine to Arterial Pressure.

The circumstance to which we have to direct our attention is the extent of pressure present in the renal capillaries, and in the glomeruli. The more the pressure of the blood in these exceeds the pressure of the fluid in the channels of the uriniferous tubules, the more rapid and extensive will be the filtration from the one into the other.

This local *capillary* blood-pressure may be **increased**—

1. By an increase of the general blood-pressure, brought about—*(a)* by an increased force, frequency, &c. of the heart's beat, *(b)* by the constriction of the small arteries supplying areas other than the kidney itself.

2. By a relaxation of the renal artery, which, as we have previously pointed out (p. 169), while diminishing the pressure in the artery itself, increases the pressure in the capillaries and small veins which it supplies. It need hardly be added that this local relaxation must either be accompanied by constriction in other vascular areas, or at all events must not be accompanied by a sufficiently compensating dilation elsewhere.

The local capillary pressure may similarly be **diminished**—

1. By a constriction of the renal artery, which, while increasing the pressure on the cardiac side of the artery, diminishes the pressure

in the capillaries and veins which are supplied by the artery. This again must either be accompanied by dilation in other vascular areas, or at least not accompanied by a compensating constriction.

2. By a lowering of the *general* blood-pressure, brought about—(a) by diminished force &c. of the heart's beat, (b) by a general dilation of the small arteries of the body at large, or by a dilation of vascular areas other than the kidneys.

Bearing these facts in mind, it becomes easy to explain many of the instances in which an increase or diminution of urine is produced by natural or artificial means. Thus section of the spinal cord below the medulla causes a great diminution, and indeed in most cases a complete or almost complete arrest of the secretion of urine. In this case the vascular areas of the body at large are cut off from their vaso-motor centre; as a consequence general vascular dilation ensues, with a great fall of the general blood-pressure. Although the renal arteries suffer with the rest in this dilation, yet since they form but a small fraction of the whole arterial system, the general dilation causes a diminished flow through them; and when the general blood-pressure falls sufficiently low (below 30 mm. mercury in the dog) the secretion of urine is totally arrested.

Stimulation of the spinal cord below the medulla, though acting in the converse direction, brings about the same result, arrest of the secretion. By the stimulation the action of the vaso-motor nerves is augmented, and constriction of the renal arteries as well as of other arteries in the body is brought about. The increase of general blood-pressure thus produced is insufficient to compensate for the increased resistance in the renal arteries; and as a consequence the flow of blood into the glomeruli is largely reduced. Indeed on inspection the kidneys are seen during the stimulation to become pale and bloodless.

Section of the renal nerves is followed by a most copious secretion, by what has been called hydruria or polyuria, the urine at the same time frequently becoming albuminous. The section of the nerves, by interrupting the vaso-motor tracts, leads to dilation of the renal arteries, and this to increased *capillary* pressure. If after section of the renal nerves the cord be divided below the medulla, the polyuria disappears; for the diminution of general blood-pressure thus produced more than compensates for the special dilation of the renal arteries. Conversely, if after section of the renal nerves the cord be stimulated, the flow of urine is still further increased, since the rise of general blood-pressure due to the general arterial constriction caused by the stimulation tends to throw still more blood into the renal arteries, on which, owing to the division of their nerves, the spinal stimulation is powerless.

Section of the splanchnic nerves, along which apparently the vaso-motor tracts from the spinal cord to the kidneys run, produces also an increased flow of urine. But the augmentation in this case is

smaller and less certain than in the case of section of the renal nerves themselves, since the splanchnic nerves govern the whole splanchnic area, and hence a large portion of the increased supply of blood is diverted from the kidney to other abdominal organs. Conversely, stimulation of the splanchnic nerves arrests the flow of urine by producing constriction of the renal arteries.

We shall have occasion in the succeeding chapter to call attention to the fact that puncture of the fourth ventricle, or mechanical irritation of the first thoracic ganglion, gives rise to the appearance of a large quantity of sugar in the urine, and at the same time causes a more copious flow of that fluid; the condition of body thus brought about is known as artificial diabetes. The presence of the sugar is not the whole cause of the increased flow, for the operation, or a similar injury to certain parts of the cerebellum¹, may give rise to an excessive secretion of urine without any sugar being present. It is probable, but not as yet clearly proved, that the increase of urine is due to dilation of the renal arteries; and this view is supported by the fact that the increase is temporarily prevented (as is also a similar diabetic increase of flow in carbonic-oxide poisoning) by stimulation of the splanchnic nerves.

Irritation of the central end of the vagus causes an increased flow of urine. This may be explained by supposing that the afferent impulses ascending the vagus inhibit that part of the vaso-motor centre which governs the renal arteries, and so produce dilation of those arteries. Possibly at the same time, as in the case of the rabbit's ear (p. 163), some amount of general constriction is brought about.

There are several diuretic drugs, whose action seems intimately connected with blood-pressure, though the phenomena to which they give rise cannot at present be completely explained. Thus when a large dose of digitalis is given, the general blood-pressure at first rapidly increases and the flow of urine is primarily diminished or even arrested. The increase of pressure seems to be due partly to an increase in the heart's beat, but chiefly to an increase in the peripheral resistance, *i.e.* to arterial constriction. Since the arrest of flow is seen to take place quite as readily in a kidney whose nerves have been divided as in one whose nerves have been left intact, it is evident that the digitalis must cause arterial constriction by acting not on the general vaso-motor centre or not on that alone, but on the peripheral vaso-motor mechanisms (cf. p. 165). The primary rise of pressure, and arrest of secretion, soon gives way to a fall of pressure and a copious flow of urine, the increase of secretion beginning first and being most marked in the kidney the nerves of which have been cut. The change of phenomena may be explained by supposing that the primary arterial constriction is succeeded by a secondary dilation, beginning first and becoming most pronounced in the kidney with divided nerves. Whether there are other causes at work must be left at the present undecided.

The experimental phenomena recorded above are thus seen to receive a fairly satisfactory explanation when they are referred

¹ Eckhard, *Beiträge*, v. (1870) 153; vi. 1, 51, 117, 175.

exclusively to variations in blood-pressure. And many of the natural variations in the flow of urine may be interpreted in this way. No fact in the animal economy is oftener or more strikingly brought home to us than the correlation of the skin and the kidneys as far as their secretions are concerned; and this seems to be maintained by means of the vaso-motor nervous mechanism. Thus when the skin is cold, its blood-vessels are, as we know, constricted. This by causing an increase of general blood-pressure, accompanied most probably by a dilation of the splanchnic vascular area, possibly by a special dilation of the renal arteries, must augment the flow through the kidneys. Conversely, the dilated condition of the arteries of a warm skin, with the consequent diminution of general blood-pressure, accompanied possibly with a corresponding dilation of the splanchnic (renal) vascular areas, would give rise to a diminished renal discharge. The effects of emotions may be explained in a similar way as essentially vaso-motor phenomena.

The increase of urine observable after taking fluids cannot be explained by reference to any direct increase of blood-pressure due to an augmentation of the quantity of blood, for, as we have seen (p. 174), an increase of the quantity of blood does not raise the general blood-pressure. Possibly the introduction of the fluid into the alimentary canal may cause a dilation of the splanchnic or renal areas either directly, or indirectly, in a reflex manner by the help of the vagi. This observation refers of course to inert fluids, such as water; the introduction of various substances in an ordinary meal may affect the flow of urine in other ways to be presently stated.

At the same time it must be remembered that here, as in the case of the salivary gland, what appears to be at first sight a simple action of vaso-motor nerves may be, after all, a direct action of nerves on secreting cells accompanied by an adjuvant but not indispensable vaso-motor action. Against such a possibility may be urged the fact that as far as we know atropin has no such effect on renal as it has on salivary secretion, and the reflection that in the case of urine, in distinction to that of saliva, a mere discharge of water from the body is one object of the renal mechanism, and this object would naturally be gained by the simpler process of filtration through blood-pressure, rather than by the more laborious method of active secretion.

Secretion by the Renal Epithelium.

So dependent indeed on blood-pressure does the secretion of urine appear to be, that many have considered the process to be simply and wholly a matter of diffusion, of filtration at a varying pressure. Thus the older view of Bowman¹—that the urine consisted essentially of two parts, *i.e.* of the water and the more general consti-

¹ *Phil. Trans.*, 1842.

tuents which made their way through the glomeruli, and of the distinct specific constituents which were discharged by the activity of the renal epithelium into the channels of the tubules—gave way very largely to the conception of Ludwig and his school, who taught that all the urine in a diluted form passed through the glomeruli, and in its descent along the tubules underwent nothing more than an appropriate concentration.

Against such a view might be urged among other *à priori* arguments the fact that, while undoubtedly the great majority of the urinary constituents readily diffuse, some of them, *ex. gr.* the pigments, do not. But we have now no need of *à priori* arguments, since Heidenhain¹ has shewn that, with regard to one substance at least, the renal epithelium does exercise a distinct secreting activity, independent of and distinct from the relations of blood-pressure. Into the veins of animals in which the urinary flow had been arrested by section of the spinal cord below the medulla, Heidenhain injected the sodium sulphindigotate, or so-called indigo-carmin. By killing the animals at appropriate times and examining the kidneys microscopically and otherwise, he was enabled to ascertain that the pigment so injected passed from the blood into the renal epithelium, and from thence into the channels of the tubules, where it was precipitated in a solid form. There being no stream of fluid through the tubules, owing to the arrest of urinary flow by means of the preliminary operation, the pigment travelled very little way down the interior of the tubules, and remained very much where it was cast out by the epithelium cells. There were no traces whatever of the pigment having passed by the glomeruli; and the cells which could be seen distinctly to take up and eject it, were those lining such portions of the tubules (*viz.* the so-called secreting tubules, intercalated tubules and portions of the loops of Henle) as from their microscopic features have been supposed to be the actively secreting portions of the entire tubules. By varying the quantity injected and the time which was allowed to elapse between the injection and subsequent inspection, Heidenhain was able to trace the material step by step into the cells, out of the cells into the interior of the tubules, and for some little distance along the tubules. The advantage of the absence of a large flow of urine is obvious; had this been present, the pigment would have been rapidly carried off immediately that it issued from the cells into the interior of the tubules. One observation he made of a peculiarly interesting character. After injecting a certain quantity of pigment, and allowing such a time to elapse as he knew from previous experiments would suffice for the passage of the material through the epithelium to be pretty well completed, he injected a second quantity. He found that the excretion of this second quantity was most incomplete and imperfect. It seemed as if the cells were *exhausted by their previous efforts*, just as a muscle which has been severely tetanized will not respond to a renewed stimulation.

¹ Pflüger's *Archiv*, IX. (1874) 1.

As far as indigo-carmin is concerned, then, we are justified in speaking of an active though not a formative secretion by means of the epithelium, which seems, in thus taking the pigment out of the blood and passing it on into the channel of the tubules, to play a part not unlike that which we ascribed (p. 247) to the epithelium cell of the villus in taking up fat from the intestine and passing it on into the lacteal. But indigo-carmin is not a natural constituent of the urine, and it would be desirable that the same activity should be proved in the case of the natural constituents. On Heidenhain's attempting to do this by the injection of urates, he found, in spite of the blood-pressure remaining below the normal, or at least not being proportionably increased, that such a copious flow of urine took place as swept away the contents of the tubules and so prevented the evidences of local activity being manifested. Still this very increase of flow, and a similar increase seen after the injection of other diuretics such as urea¹, sodium chloride, potassium nitrate, &c., unaccompanied by any corresponding change in blood-pressure, may, until it has been otherwise explained, be regarded as at least an indication that the epithelium cells have an active share in the secretion of even the fluid parts of urine, and that they may be called into activity by substances behaving to them, in some way or other, as chemical stimuli.

Although therefore much yet remains to be done, before this question can be regarded as thoroughly settled; still, leaning on the analogy of other glands, we shall probably not err in supposing that future researches will be able to demonstrate with exactitude an active function of the renal epithelium, and at the same time to mark out distinctly the limits and mutual relations of active secretion and passive mechanical filtration of urine.

One consideration, of quite secondary importance in the glands which have been previously studied, acquires great prominence, when the kidney is being studied. In studying the pancreas and gastric glands, we concluded without much discussion that the zymogen and pepsinogen were formed in the epithelium cells; for no great manufacture of these substances is going on in other parts of the body. The kidney however is emphatically an excreting organ: its great function is to get rid of substances produced by the activity of other tissues; its work is not to form but to eject. There can be no doubt, to put forward a strong instance, that with regard to urea it would be absurd to suppose that the whole series of changes from the proteid condition to the urea stage is carried on by the kidney. But there still remains the question, Are any of the stages carried on in the kidney, and if so what? Is the secreting activity of the renal epithelium confined, as was suggested in our early remarks on secretion, p. 205, to picking out the already formed urea from the blood? Or does the secreting cell of the tubule receive from the blood some

¹ Ustimowitsch, *Ludwig's Arbeiten*, 1870, p. 199.

antecedent of urea, and in the laboratory of its protoplasm convert that antecedent of urea into urea itself? and if so, what is that antecedent which comes to the kidney in the blood of the renal artery? And so with many other of the urinary constituents.

In order to complete our study of renal activity, this question ought to be considered now; but for many reasons it will be more convenient to defer the matter to the succeeding chapter, in which we deal with the metabolic events of the body in general.

SEC. 3. MICTURITION.

The urine, like the bile, is secreted continuously; the flow may rise and fall, but, in health, never absolutely ceases for any length of time. The cessation of renal activity, the so-called suppression of urine, entails speedy death. The minute streams passing continuously, now more rapidly now more slowly, along the collecting and discharging tubules are gathered into the renal pelvis, whence the fluid is carried along the ureters by the peristaltic contractions of the muscular walls of those channels (see p. 82) into the urinary bladder. When a ureter is divided in an animal, and a cannula inserted, the urine may be observed to flow from the cannula drop by drop, slowly or rapidly according to the rate of secretion. In the urinary bladder, the urine is collected, its return into the ureters being prevented by the oblique valvular nature of the orifices of those tubes, and its discharge from thence in considerable quantities is effected from time to time by a somewhat complex muscular mechanism, of the nature and working of which the following is a brief account. The involuntary muscular fibres forming the greater part of the vesical walls are arranged partly in a more or less longitudinal direction forming the so-called detrusor urinæ, and partly in a circular manner, the circular fibres being most developed round the neck of the bladder and forming there the so-called sphincter vesicæ. After it has been emptied the bladder is contracted and thrown into folds; as the urine gradually collects, the bladder becomes more and more distended. The escape of the fluid is however prevented by the resistance offered by the elastic fibres of the urethra which keep the urethral channel closed. Some maintain that the tonic contraction of the sphincter vesicæ aids in or indeed is the chief cause of this retention. When the bladder has become full, we feel the need of making water, the sensation being heightened if not caused by the trickling of a few drops of urine from the full bladder into the urethra. We are then conscious of an effort; during this effort the bladder is thrown into a long continued contraction of an obscurely peristaltic nature, the force of which is more than sufficient to overcome the elastic resistance of the urethra, and the urine issues in a stream, the sphincter vesicæ, if it act as a sphincter, being at the same time relaxed after the fashion of the sphincter ani. In its passage along the urethra, the exit of the urine

is forwarded by irregularly rhythmic contractions of the bulbo-cavernosus or ejaculator urinæ muscle, and the whole act is further assisted by abdominal pressure exerted by means of the abdominal muscles, very much the same as in defæcation.

The continuity of the sphincter vesicæ with the rest of the circular fibres of the bladder suggests that it probably is not a sphincter, but that its use lies in its contracting after the rest of the vesical fibres, and thus finishing the evacuation of the bladder. On the other hand, the fact that the neck of the bladder can withstand a pressure of 20 inches of water so long as the bladder is governed by an intact spinal cord, but a pressure of 6 inches only when the lumbar spinal cord is destroyed or the vesical nerves are severed, affords very strong evidence in favour of the view that the obstruction at the neck of the bladder to the exit of urine depends on some tonic muscular contraction maintained by a reflex or automatic action of the lumbar spinal cord.

Micturition therefore seems at first sight, and especially when we appeal to our own consciousness, a purely voluntary act. A voluntary effort throws the bladder into contractions, an accompanying voluntary effort throws the ejaculator and abdominal muscles also into contractions, and the resistance of the urethra being thereby overcome the exit of the urine naturally follows. If we adopt the view of a sphincter vesicæ, we have to add to the above simple statement the supposition that the will, while causing the detrusor urinæ to contract, at the same time lessens the tone of the sphincter, probably by inhibiting its centre in the lumbar cord.

There are two facts however which prevent the acceptance of so simple a view. In the first place Goltz¹ has shewn that quite normal micturition may take place in a dog in which the lumbar region of the spinal cord has been completely separated by section from the dorsal region. In such a case there can be no exercise of volition, and the whole process appears as a reflex action. When the bladder is full (and otherwise apparently under the circumstances the act fails) any slight stimulus, such as sponging the anus or slight pressure on the abdominal walls, causes a complete act of micturition; the bladder is entirely emptied, and the stream of urine towards the end of the act undergoes rhythmical augmentations due to contractions of the ejaculator urinæ. These facts can only be interpreted on the view that there exists in the lumbar cord (of the dog) a micturition centre capable of being thrown into action by appropriate afferent impulses, the action of the centre being such as to cause a contraction of the walls of the bladder and of the ejaculator urinæ, and possibly at the same time to suspend the tone of the sphincter vesicæ. Similar instances of reflex micturition have been observed in cases of paralysis from disease or injury of the spinal cord; and involuntary micturition is common in children, as the result of irritation of the pelvis and genital organs, or of emotions. In the adult too, as

¹ Pflüger's *Archiv*, VIII. (1874) 474.

Shylock has informed us, emotions, or at least sensory impressions, may in a reflex manner be the cause of micturition. In such cases we may fairly suppose that the centre in the lumbar cord is affected by afferent impulses descending from the brain. And this leads us to the conception that when we make water by a conscious effort of the will, what occurs is not a direct action of the will on the muscular walls of the bladder, but that impulses started by the will descend from the brain after the fashion of afferent impulses and thus in a reflex manner throw into action the micturition centre in the lumbar spinal cord. Nor is this view negatived by the fact that paralysis of the bladder, or rather inability to make water either voluntarily or in a reflex manner, is a common symptom of spinal disease or injury. Putting aside the cases in which the reflex act is not called forth because the appropriate stimulus has not been applied, the failure in micturition under these circumstances may be explained by supposing that the shock of the spinal injury or some extension of the disease has rendered the lumbar centre unable to act.

In the second place, in cases of urethral obstruction, where the bladder cannot be emptied when it reaches its accustomed fullness, the increasing distension sets up fruitless but powerful contractions of the vesical walls, contractions which are clearly involuntary in nature, which wane or disappear, and return again and again in a completely rhythmic manner, and which may be so strong and powerful as to cause great suffering. It seems that fibres of the bladder, like all other muscular fibres, have their contractions augmented in proportion as they are subjected to tension (see p. 69). Just as a previously quiescent ventricle of a frog's heart may be excited to a rhythmic beat by distending its cavity with blood, so the quiescent bladder is excited, by the distension of its cavity, to a peristaltic action which in normal cases is never carried beyond a first effort, since with that the bladder is emptied and the stimulus is removed, but in cases of obstruction is enabled clearly to manifest its rhythmic nature.

The so-called incontinence of urine in children is in reality an easily excited and frequently repeated reflex micturition. In cases of spinal disease another form of incontinence is common. The bladder becoming full, but, owing to a failure in the mechanism of voluntary or reflex micturition, being unable to empty itself by a complete contraction, a continual dribbling of urine takes place through the urethra, the fulness of the bladder being sufficient to overcome the elastic resistance, or the tone of the sphincter suffering from the spinal affection and becoming permanently inhibited.

The latter view seems improbable, and there is no satisfactory evidence that intrinsic contractions of the bladder do not occur in these cases.

CHAPTER V.

THE METABOLIC PHENOMENA OF THE BODY.

WE have followed the food through its changes in the alimentary canal, and seen it enter into the blood, either directly or by the intermediate channel of the chyle, in the form of peptone (or otherwise modified albumin), sugar (lactic acid), and fats, accompanied by various salts. We have further seen that the waste products which leave the body are urea, carbonic acid and salts. We have now to attempt to connect together the food and the waste products; to trace out as far as we are able the various steps by which the one is transformed into the other, and to inquire into the manner in which the energy set free in this transformation is distributed and made use of.

The master tissues of the body are the muscular and nervous tissues; all the other tissues may be regarded as the servants of these. And we may fairly presume that besides the digestive and excretory tissues which we have already studied, many parts of the body are engaged either in further elaborating the comparatively raw food which enters the blood, in order that it may be assimilated with the least possible labour by the master tissues, or in so modifying the waste products which arise from the activity of the master tissues that they may be removed from the body as speedily as possible. There can be no doubt that manifold intermediate changes of this kind do take place in the body; but our knowledge of the matter is at present very imperfect. In one or two instances only can we localize these metabolic actions and speak of distinct metabolic tissues. In the majority of cases we can only trace out or infer chemical changes without being able to say more than that they do take place somewhere; and in consequence, perhaps somewhat loosely, speak of them as taking place in the blood.

SEC. 1. METABOLIC TISSUES.

The History of Glycogen.

The best-known and most carefully studied example of metabolic activity is the formation of glycogen in the hepatic cells.

Claude Bernard¹, in studying the history of sugar in the economy, was led to compare the relative quantities of sugar in the portal and hepatic veins, expecting to find that the sugar possibly diminished in the passage of the blood through the liver; he was astonished to discover that, on the contrary, the quantity was vastly increased. He found, and anyone can make the observation, that when an animal living under ordinary conditions is killed, not only does the hepatic blood contain a considerable amount of sugar, even when there is little or none in the portal blood, but that an aqueous infusion of the liver is rich in sugar (grape-sugar). Not only so, but the sugar continues to be present in the liver when all blood has been washed out of the organ by a stream of water driven through the portal vein, and goes on increasing in amount for some hours after death. Only one interpretation of these facts is possible; so far from the liver destroying or converting the sugar brought to it by the portal vein, it is clearly a source of sugar; the hepatic tissue evidently contains some substance capable of giving rise to the presence of sugar. Bernard further found that when the liver was removed from the body immediately after death, and, after being divided into small pieces, was thrown into boiling water, the infusion or decoction contained very little sugar, and that the small quantity which was present did not increase even when the decoction was allowed to stand for some time. The decoction, however, was peculiarly opalescent, indeed milky in appearance; whereas the decoction of a liver which had been allowed to remain exposed to warmth for some time after death, before being boiled, and which accordingly contained a large amount of sugar, was quite clear. On adding saliva, or other amyolytic ferment, to the opalescent, sugarless or nearly sugarless, decoction and exposing it to a gentle warmth (35°—40°), the opalescence disappeared; the fluid became clear, and was then found to contain a considerable quantity of sugar, the sugar thus formed being identical with ordinary grape-sugar. Here again the explanation was obvious. The opalescence of the decoction of boiled liver is due to the presence of a body which is capable of being converted by the action of a ferment into grape-sugar, and is therefore of the nature of starch. At the moment of death the liver must contain a considerable quantity of this substance, which after death becomes gradually converted into sugar, apparently through the action of some amyolytic ferment present in the liver itself or retained within the hepatic vessels. Hence the post-mortem appearance of a continually increasing quantity of sugar. By precipitating the opalescent decoction with alcohol, by boiling the precipitate with alcohol containing potash, whereby the proteid impurities clinging to it were destroyed, and by removing adherent fats by ether, Bernard was able to obtain this sugar-producing or glycogenic substance in a pure state as a white amorphous powder, with a composition of $C_6H_{10}O_5$, and therefore evidently a starch.

¹ *Nour. Fonct. du Foie*, 1853.

Its most striking differences from starch were that it gave a deep red and not a blue colour with iodine, and that it dissolved in water forming a milky fluid. He gave to it the name of *glycogen*.

Since Bernard's discovery glycogen has been recognised as a normal constituent, variable in quantity, of hepatic tissue both in vertebrate and invertebrate animals. That it is present in the hepatic cells, and not simply contained in the hepatic blood, is shewn by the fact that it remains in the liver after all blood has been washed out of that organ. It has also been found in the placenta, in muscle, white corpuscles, testes, brain, and in other situations; the tissues of the embryo at an early stage, especially before the liver has become functionally active, are particularly rich in it.

Origin of the hepatic Glycogen. Bernard found glycogen to be present in the livers of dogs which had been fed exclusively on meat; and was accordingly inclined at first to the opinion that the glycogen in the liver was unconnected with the carbohydrates taken as food and derived exclusively from the proteids, that its presence in fact indicated the manufacture of non-nitrogenous out of nitrogenous material. Flesh, however, especially that of the horse (so frequently used as food for dogs), contains glycogen, or at least sugar, and this might serve as the source of the glycogen in the liver of the flesh-fed dogs. Subsequent and more exact inquiries have led to the following results.

When food is withheld from an animal, the glycogen in the liver diminishes, rapidly at first, but more slowly afterwards. Even after some days' starvation a small quantity is frequently still found; but in rabbits, at all events, the whole may eventually disappear. A diet of fibrin with fat and a little salt does not appreciably increase the amount beyond that found in total abstinence. All observers agree that fat alone does not produce any increase. A meat diet does produce a certain amount. Cereals increase the amount considerably, but the greatest and most rapid augmentation is effected by sugar or starch, and it would seem especially by sugar¹. Thus in hens the percentage of glycogen reckoned for the wet liver was, after two days' starvation, .5, after a diet of fibrin and fat .38, after meat 1.06, after barley 3.62, after sugar with fibrin 9.26, the diet in each case being administered for two days. Similar results have been gained on rabbits and rats; and though perhaps a distinction has not been drawn with sufficient accuracy between carnivorous and herbivorous animals, they may be taken as holding good for animals of all kinds. Dock found that when an animal (rabbit) was starved until the glycogen had wholly disappeared, the introduction of sugar into the alimentary canal gave rise to the presence of glycogen in the liver within a few hours, whereas water or proteids

¹ MacDonnell, *Nat. Hist. Rev.* 1863, p. 541. Tscherinoff, Moleschott's *Untersuch.* x. (1870) 226. Dock, Pflüger's *Archiv*, v. (1872) 71. Mering, Pflüger's *Archiv*, xiv. (1877) 274. Cf. also Pavy on Diabetes.

had no such effect. All observers, in fact, are agreed that the presence of glycogen in any considerable quantity in the liver is more directly influenced by saccharine or amylaceous than by any other kind of food.

The question then arises, Is the accumulation of glycogen in the liver caused by the sugar which reaches the liver through the blood becoming directly reconverted into the starch-like glycogen and deposited in the hepatic cells; or, has the hepatic glycogen quite a different origin, being formed in the hepatic cells out of the breaking up of their protoplasm, and being carried thence and consumed in some way or other as the needs of the economy for carbohydrate material demand, so that the excess which appears in the liver after an amylaceous diet is due to the fact that the carbohydrates taken as food cover the necessary expenditure and prevent any demand being made on the hepatic store? The answer to these questions must depend on the answer to another question, What becomes of the hepatic glycogen during life? Is it reconverted little by little into sugar which, passing into the blood of the hepatic veins, is oxidized or otherwise made use of, or is it in the hepatic cells converted into some more complex substance, it may be fat or some other body?

Fate of the hepatic Glycogen. The view that glycogen is converted into fat is based chiefly on the fact, that, as we shall see later on, the carbohydrates of the food are undoubtedly, in some way or other, a source of the fat of the body, that a large quantity, frequently a very large quantity, of fat is found in the hepatic cells, and that the quantity of fat present seems to be increased by such diets as naturally increase the glycogen in the liver. But we shall have occasion to point out that the direct conversion of carbohydrates into fat is at least disputed; and no one has yet been able even to suggest the way in which glycogen could be converted into fat. Indeed the discussion as to the fate of the hepatic glycogen has been made to turn chiefly on the question, whether normally, during life, there is evidence of the reversion of the glycogen into sugar, whether the blood of the hepatic vein contains in life more sugar than that of the portal vein. Pavy was the first to point out that the blood in the hepatic vein, if care be taken to keep the animal in a perfectly normal condition, contains no more sugar than does the blood of the right auricle or of the portal vein, and indeed that the liver itself, if examined before *any* post-mortem changes have had time to develop themselves, is free from sugar; in this he has been supported by Tscheringoff, and others. Some observers, on the contrary, support the old opinion of Bernard, that the liver does normally discharge a certain quantity of sugar into the hepatic veins. In presence of the conflicting evidence, we shall not go far wrong in assuming that this older view is not as yet clearly disproved¹.

¹ Cf. Bernard, *Leçons sur le Diabète*, 1877.

The matter is probably one which cannot be settled by this method. The quantitative determination of sugar in blood is open to many sources of error. When the quantity of blood which is continually flowing through the liver is taken under consideration, it is obvious that an amount of sugar, which in the specimen of blood taken for examination fell within the limits of errors of observation, might when multiplied by the whole quantity of blood, and by the number of times the blood passed through the liver in a certain time, reach dimensions quite sufficient to account for the conversion into sugar of the whole of the glycogen present in the liver at any given time. Normal hepatic blood was obtained by Pavy, by means of an ingenious catheterisation. He introduced through the jugular vein, into the superior, and so into the inferior vena cava, a long catheter, constructed in such a manner that he could at pleasure plug up the vena cava below the embouchement of the hepatic veins, and draw blood exclusively from the latter; or vice versa.

If however we admit that the liver is either continually or at intervals reconverting its glycogen into sugar, we are led to the conclusion that the hepatic glycogen is in fact a reserve store of carbohydrate material. And we can accept this conclusion without being able to say definitely what becomes of the sugar thus thrown into the hepatic blood. We have already (p. 286) urged the difficulties which are occasioned by the view that sugar is oxidized in the blood, since we have no proof that the blood can oxidize sugar. Such evidence as we have has a contrary tendency. We may indeed suppose that the sugar is converted into lactic acid, and that lactates are directly oxidized in the blood; but we have no positive proof that any such oxidation does or can take place.

The fact that the amount of sugar in shed blood appears to diminish gradually when the blood is allowed to stand for some time¹ is not a sufficient argument that sugar is oxidized by the circulating blood².

On the other hand, there are theoretical reasons supporting the view that a certain average composition is necessary for that great internal medium the blood, in order that the several tissues may thrive upon it to the best advantage, one element of that composition being a certain percentage of sugar. We may suppose that all or several of the tissues are continually drawing upon the blood for sugar, and that hence a certain supply must be kept up to meet this demand: we may imagine, for instance, that muscle is continually, or from time to time, needing sugar to build up the contractile material. Hence, when sugar is present in the blood beyond what is needed, the excess is cast out of the body by the kidneys, except that which, passing by the portal vein, becomes converted into glycogen; and, as a matter of fact, we know that more sugar can be injected into the portal than into the jugular vein before it reappears in the urine. When, again, the sugar in the blood

¹ Bernard, *op. cit.* Pavy, *Proc. Roy. Soc.* xxvi. (1877) p. 346.

² Cf. Hoppe-Seyler, *Pflüger's Archiv*, vii. (1873) p. 399.

is deficient, the lack is at once supplied by a conversion of the hepatic glycogen. Moreover, this view, that the glycogen of the liver is a reserve fund of carbohydrate material, is strongly supported by the analogy of the migration of starch in the vegetable kingdom. We know that the starch of the leaves of a plant, whether itself having passed through a glucose stage or not, is normally converted into sugar, and carried down to the roots or other parts, where it frequently becomes once more changed back again into starch. And when we consider that at every meal an excess of carbohydrates is thrown into the system, far more than is needed for the time being, and yet not more than will be needed before the next meal, it appears only natural that this excess should be at once, and without much labour, laid up as a store of carbohydrate material, upon which the economy can make a call as occasion demands. And this suggestion is supported by the fact that whereas the glycogen of the liver varies much according to the food taken, that present in the muscles is fairly constant; indeed glycogen may still be found in the muscles when it has wholly disappeared from the liver. We may infer from this that the glycogen in the muscle is, so to speak, functional material, *i. e.* material about to be used up in the metabolism attendant on muscular contraction, while that in the liver has no such purpose, but is simply laid by for the future use either of muscles or of other tissues. But if we entertain the view that the hepatic glycogen is simply store glycogen, waiting to be converted into sugar little by little as the needs of the economy demand, and not glycogen on its way to take part, through the agency of the hepatic protoplasm, in the formation of some more complex compound, there is no difficulty in supposing that the glycogen which makes its appearance in the liver after an amylaceous meal, arises from a direct conversion of the grape-sugar carried to the liver by the portal vein, the sugar becoming through some action of the hepatic protoplasm dehydrated into starch, just as in the alimentary canal starch is hydrated into sugar by the action of the salivary and pancreatic ferments. Vegetable protoplasm can undoubtedly convert both starch into sugar and sugar into starch; and there are no *à priori* arguments or positive facts which would lead us to suppose that the activity of animal protoplasm cannot accomplish the latter as well as the former of these changes. At the same time it must be remembered that this view does not preclude the possibility of glycogen, in the absence of a supply of sugar from the portal blood, being formed in other ways.

It has been stated¹ that glycerine introduced into the alimentary canal gives rise to an increase of glycogen in the liver; this, if true, shews undoubtedly that hepatic glycogen may be formed in other ways than by the direct dehydration of sugar. Milk-sugar, and inulin also, produce

¹ Weiss, *Wiener Sitzungsberichte*, Bd. 67. Luchsinger, *Pflüger's Archiv*, VIII. (1874) 289.

an increase of hepatic glycogen, the glycogen so appearing having all the normal characters. It is difficult to suppose that glycerine can be directly converted into glycogen; and we are led to suspect, that in this case, the glycerine, by becoming oxidized, causes a saving in the expenditure of carbohydrate material, and thus indirectly leads to an accumulation of glycogen. But this view is opposed by the fact that lactic acid, to which we should readily turn as being eminently oxidizable, and therefore eminently calculated to save carbohydrate expenditure, does not lead to any similar storing up of glycogen. And Luchsinger¹ states that glycerine injected in considerable quantities under the skin, and absorbed from the subcutaneous tissue, leads to no increase of glycogen; so that the glycogen which appears in the liver when glycerine is introduced into the alimentary canal would seem to come from some conversion of the glycerine as it reaches the hepatic cells by the portal blood; difficult as any chemical conception of that conversion may be.

The statements with regard to the glycogenic influence of gelatine are conflicting². The balance of evidence is perhaps in favour of glycogen being stored up in the liver as the result of a diet of pure gelatine. This would indicate a transformation into glycogen of the non-nitrogenous moiety resulting from that splitting up of gelatine of which we shall have to speak later on.

The question may be asked, How is it possible for the glycogen, which at the temperature of the body is so readily converted into sugar by the action of ferments, to remain as glycogen in the presence of the ferment which, as we know from post-mortem changes, exists in the hepatic tissue? We can only answer that the solution of this problem is of the same kind as that of the problems, why blood does not clot in the living blood-vessels, why the living muscle does not become rigid, and why the living stomach or pancreas does not digest itself. It might be added, bearing in mind the history of the fibrin ferment, that we have no proof that such an amyolytic ferment does exist in the living hepatic cells. It is possible that the ferment which can be extracted after death only makes its appearance as the result of changes which have taken place in the protoplasm of the hepatic cells.

It is clear that the glycogen is contained in the hepatic cells; but it is by no means certain that it exists there in what may be called a free state. The fact that under the microscope the hepatic cells give with iodine the colour reaction of glycogen, is no proof of the glycogen being free. It has been described as sometimes occurring in granules; but this, if ever, is certainly not always its condition. It is worthy of notice that all the means adopted to extract glycogen from a tissue are such as would readily decompose unstable complex compounds. If we advance the view that the glycogen of the hepatic protoplasm does not exist as an independent body, simply mixed with the other protoplasmic constituents, but is loosely connected with other (possibly proteid) substances as part of a very complex

¹ *Op. cit.*

² Bernard, MacDonnell, Luchsinger, Mering, *op. cit.* Wolffberg, *Zt. f. Biol.* XIII. p. 266.

compound, few facts would be found opposing, and many supporting, such a view.

Diabetes. Natural diabetes is a disease characterized by the appearance of a large quantity of sugar in the urine. Into the pathology of the various forms of this disease it is impossible to enter here; but a temporary diabetes, the appearance for a while of a large quantity of sugar in the urine, may be artificially produced in animals in several ways. If the medulla oblongata of a well-fed rabbit be punctured in the region which we have previously described (p. 158) as that of the vaso-motor centre (the area marked out by Eckhard as the diabetic area agreeing very closely with that defined by Owsjanikow as the vaso-motor area), though the animal need not necessarily be in any other way obviously affected by the operation, its urine will be found, in an hour or two, or even less, to contain a considerable quantity of sugar, and to be increased in amount. A little later the quantity of sugar will have reached a maximum, after which it declines, and in a day or two, or even less, the urine will be again perfectly normal. The better fed the animal, or, more exactly, the richer in glycogen the liver at the time of the operation, the greater the amount of sugar. If the animal be previously starved so that the liver contains little or no glycogen, the urine will after the operation contain little or no sugar. It is clear that the urinary sugar of this form of artificial diabetes comes from the glycogen of the liver. The puncture of the medulla causes such a change in the liver that the previously stored-up glycogen disappears, and the blood becomes loaded with sugar, much if not all of which passes away by the urine. In the absence of any proof to the contrary, we may assume that in this form of artificial diabetes the glycogen previously present in the liver becomes converted into sugar, just as we know that it does become so converted by post-mortem changes. The glycogenic function of the liver is therefore subject to the influence of the nervous system, and in particular to the influence of a region of the cerebro-spinal centre which we already know as the vaso-motor centre, or at least of a part of that region. We cannot at present define clearly the nature of that influence. We cannot say whether the temporary diabetes is a simple effect of vascular dilation, or of some direct action of the nerves on the metabolic activity of the hepatic protoplasm. The path of the influence may be traced along the cervical spinal cord (and not along the vagi, though the roots of these nerves lie so close to the diabetic spot), as far down as (in rabbits) the level of the third or fourth dorsal vertebra¹, or even a little lower, from the spinal cord to the first thoracic ganglion, and from thence to the liver by some channel or channels at present undetermined.

According to Eckhard² the phenomena are those of irritation, and not of the simple withdrawal of any accustomed nervous influence. He states

¹ Eckhard, *Beiträge*, viii. (1877) p. 79.

² *Beiträge*, iv. (1869) 1; vii. 1.

that while mechanical injury of the first thoracic ganglion (see fig. 32) will produce diabetes, no such effect is produced if the ganglion be carefully removed, or if its connections with the spinal cord or with the remainder of the thoracic chain be completely divided.

Cyon and Aladoff¹, on the contrary, regard the whole matter as one of simple loss of vascular tone. They state that the diabetic puncture produces dilation of the small branches of the hepatic artery, from injury to the corresponding portion of the general vaso-motor centre, and accordingly find, in opposition to Eckhard, that simple division of the nervous path, removal of the first thoracic ganglion, or division of certain (variable) nerves proceeding from it, produces diabetes equally well as irritation of the ganglion. Eckhard found that simple section of the splanchnic nerves not only did not produce diabetes but even prevented its occurrence when performed previously to the diabetic puncture. On the hypothesis that the phenomena in question are those of irritation and not of paralysis, this fact would seem to shew that the splanchnics serve as the channels by which the impulses set up in the medulla, thoracic ganglion, &c., reach the liver. Cyon and Aladoff however regard the absence of diabetes after simple section of the splanchnics as a proof that the vaso-motor fibres concerned in the matter pass to the liver by some other channel than the splanchnics; and they explain the preventive influence of previous section of the splanchnics, by supposing that this operation, by withdrawing a large quantity of blood into the abdominal organs, prevents the effects of the dilation of the comparatively small hepatic artery from manifesting themselves. For according to them, it is not the total quantity of blood, but the relative proportion of arterial blood reaching the liver, which determines the appearance of the sugar.

Simple section of the spinal cord (in rabbits) sometimes does and sometimes does not produce diabetes, and in all cases the effect appears rapidly and soon disappears. Complete section of the spinal cord at any height down to the level of the third or fourth dorsal vertebra renders the diabetic puncture ineffectual², and prevents the diabetes of morphia poisoning from being developed. Section of the vagi may produce a very slight and passing diabetes, but stimulation of the central end of either vagus may give rise, apparently by reflex excitation of the medullary centre, to a marked quantity of sugar in the urine. The diabetic puncture is in no way interfered with by previous section of both vagi.

Artificial diabetes is also a prominent symptom of urari poisoning. This is not due to the artificial respiration, which is had recourse to in order to keep the urarized animals alive; because, though disturbance of the respiratory functions sufficient to interfere with the hepatic circulation may produce sugar in the urine, artificial respiration may be carried on without any sugar making its appearance. Moreover, it is seen in frogs, in which respiration can be satisfactorily carried on without any pulmonary respiratory movements.

A very similar diabetes is seen in carbonic oxide poisoning; and is one of the results of a sufficient dose of morphia or of amyl nitrate.

¹ *Bull. Acad. Imp. Sci. St Pétersb.* xvi. (1871) 303.

² Eckhard, *Beiträge*, viii. 79.

According to Dock¹, sugar appears in the urine of urarized mammals, even when they are starving and presumably contain no glycogen in their livers. If this be so, urari diabetes must have quite a different causation from puncture diabetes; but Winogradoff² found no sugar in the urine of curarized frogs from which the livers had been removed, and Saikowsky³ found that in mammals after arsenic poisoning urari did not produce diabetes, shewing that if in urari poisoning the sugar does not come from the liver but from the muscles, arsenic has a like effect in preventing the accumulation of glycogen in the latter as in the former.

Eckhard⁴ found that morphia diabetes was, like the puncture diabetes, prevented by section of the splanchnics or by section of the spinal cord above the level of the third or fourth dorsal vertebra. The drug appears therefore to act through the medullary diabetic centre.

The subcutaneous injection of glycerine prevents (but not in all cases, and not always effectually) the appearance of diabetes after the puncture⁵ or after morphia poisoning. The reason of this is not at present clear. The urine at the same time becomes bloody.

The injection of glycogen in sufficient quantity into the blood gives rise in the urine not only to sugar but to a much larger quantity of a substance identical apparently with Brücke's achroodextrin⁶.

There can be no doubt that in diabetes, arising from whatever cause, the sugar appears in the urine because the blood contains more sugar than usual. The system can only dispose (either by oxidation, or as seems more probable in other ways) of a certain quantity of sugar in a certain time. Sugar injected into the jugular vein reappears in the urine, whenever the injection becomes so rapid that the percentage of sugar in the blood reaches a certain (low) limit. Sugar in the urine means an excess of sugar in the blood. How in natural diabetes that excess arises, we have at present no facts to shew; but it is extremely probable that the sources of the excess may be various, and hence that several distinct varieties of diabetes may exist. In one among many points, the clinical history of diabetes throws light on the possible sources of glycogen. While in many, especially of the less severe cases of diabetes, withdrawal of all amylaceous food is followed by a disappearance of sugar from the urine, in many instances the sugar continues to be discharged even though the diet be perfectly free from carbohydrates; and in many other cases the sugar in the urine is far in excess of that taken as food. In these cases the sugar must have some non-amylaceous source; from this we infer that glycogen also may have a similar origin; and the fact that the urea is increased (and that too in some cases in ratio with the sugar⁷) in diabetes, suggests that the sugar may arise from proteids which have been split up into a nitrogenous (urea) and a non-nitrogenous moiety. It has been shewn by Wickham Legg, and confirmed

¹ *Op. cit.*

² Virchow's *Archiv*, xxvii. (1863) p. 533.

³ *Centrbt. Med. Wiss.* 1865, p. 769.

⁴ *Op. cit.*

⁵ Luchsinger, Pflüger's *Archiv*, xi. (1875) 502.

⁶ Boehm and Hoffmann, *Archiv Exp. Path.* vii. (1877) 489.

⁷ Ringer, *Med. Chir. Trans.* XLIII.

by Von Wittich, that ligation of the bile-ducts causes a disappearance of glycogen from the liver, and that (four or six days) after the ligation the diabetic puncture produces no diabetes. This cannot be explained by supposing that the glycogen formed previous to the operation is rapidly converted into sugar by a ferment developed in the stagnant bile, for no sugar appears in the urine. We are rather led to infer that the formation of the glycogen is prevented by interference with the nutritive functions of the hepatic cells.

Various suggestions have been made with reference to the chemical ways in which carbohydrate material might make its appearance during hepatic metabolism. It has been pointed out, for instance, that proteid material might be split up into glycogen and the bile-acids, or that glycin might be split up into urea and glucose ($4\text{C}_2\text{H}_5\text{NO}_2 = 2\text{CH}_4\text{N}_2\text{O} + \text{C}_6\text{H}_{12}\text{O}_6$). But these views must at present be considered as suggestions only.

The History of Fat. Adipose Tissue.

Of all the tissues of the body adipose tissue is the most fluctuating in bulk; within a very short space of time a large amount of adipose tissue may disappear, and within an almost equally short time the quantity present in a body may be several times multiplied. Histological inquiries teach us that when an animal is fattening the minute drops or specks of fat normally present in certain connective-tissue corpuscles are seen to increase in number, the protoplasm enlarging at the same time. As these specks increase they coalesce into drops, which by similar coalescence form larger drops, until, the protoplasm first ceasing to increase and then diminishing, the original connective-tissue corpuscle is transformed into a fat-cell, with a remnant only of protoplasm gathered round the nucleus and forming an imperfect envelope round the enlarged contents. When, on the contrary, an animal is fasting, the fat seems in some way to escape from the cell, which it may leave as an empty bag collapsed around the nucleus. These facts point to the conclusion that the fat of adipose tissue is not simply and mechanically collected in the cell, but is formed by the active agency of the cell, being apparently the result of a breaking up of the protoplasm; when formed, however, it appears to be discharged from the cell in a more or less mechanical manner, as the needs of the economy demand. And this view is supported by the fact that protoplasm, wherever occurring, both during life and after death (when it could not possibly be supplied with fat from without), is subject to fatty degeneration, in which the fat evidently arises, in large part at least, from the breaking up of proteid compounds.

On the other hand, we have traced the fats taken as food, and found that they pass with comparatively little change from the alimentary canal into the blood, either directly, or through the intermediate passage of the chyle. We might infer from this that an

excess of fat thus entering the blood would naturally be simply stored up in the available adipose tissue, without any further change, the connective-tissue corpuscles after the fashion of an amœba eating the fat brought to them but not digesting it, simply keeping it in store till it was wanted elsewhere.

Which of these views is the true one, or how far are both these operations carried on in the animal body? In the first place, it is evident that in an animal fattened on ordinary fattening food, only a small fraction of the fat stored up in the body can possibly come direct from the fat of the food. Long ago, in opposition to the views of Dumas and his school, who taught that all construction of organic material, that all actual manufacture of protoplasm or even of its organic constituents, was confined to vegetables and unknown in animals, Liebig shewed that the butter present in the milk of a cow was much greater than could be accounted for by the scanty fat present in the grass or other fodder she consumed. He also urged, as an argument in the same direction, that the wax produced by bees is out of all proportion to the fat contained in their food, consisting as this does chiefly of sugar. And Lawes and Gilbert¹ have shewn by direct analysis that for every 100 parts of fat in the food of a fattening pig, 472 parts were stored up as fat during the fattening period. It is clear that fat is formed in the body out of something which is not fat.

There are two possible sources of this manufactured fat. In treating of digestion (p. 242), we referred to the possibility of digested carbohydrates becoming converted into fats by the butyric acid fermentation. Analogous ferment-actions may similarly elaborate other fats. And there can be no doubt that a carbohydrate diet is most efficacious in producing an accumulation of fat in the body. Sugar or starch, in some form or other, is always a large constituent of ordinary fattening foods.

Another source of fat is to be found in the proteids. We have seen that the urea of the urine practically represents the whole of the nitrogen which passes through the body. Now in any given quantity of urea the amount of carbon is far less than that found in the quantity of proteid containing the same amount of nitrogen. Thus the percentage composition of the two being respectively,

	Carbon.	Hydrogen.	Oxygen.	Nitrogen.	Sulphur.
Urea	20·00	6·66	26·67	46·67	
Proteid	53	7·30	23·04	15·53	1·13

100 grms. of urea contain about as much nitrogen as 300 grms. of proteid; but the 300 grms. of proteid contain 139 grms. (159 - 20) more carbon than do the 100 grms. urea. Hence the 300 grms. of proteid in passing through the body and giving rise to 100 grms. of urea, would leave behind 139 grms. of carbon, in some combination or

¹ *Phil. Trans.* 1860.

other; and this surplus of carbon, if the needs of the economy did not demand that it should be immediately converted into carbonic acid and thrown off from the body, might be deposited somewhere in the form of fat. We have already seen, in treating of the action of the pancreatic juice (p. 201), that there is evidence of a fatty element being thrown off from the complex proteid compound in the very process of digestion.

It is clear that a construction of fat does occur in the body somewhere. What limits can we place on the degree to which this construction is carried? In reference to this point it is worthy of notice that the composition of fat varies in different animals. The fat of a man differs from the fat of a dog, even if both feed on exactly the same food, fatty or otherwise. Were the fat which is taken as food stored up as adipose tissue directly and without change, recourse being had to other sources of food for the construction of fat only in cases where the fat in the food was deficient, we should expect to find that the constitution of the fat of the body would vary greatly with the food. So far from this being the case, Subbotin¹ finds that the fat of the dog is, as far as composition is concerned, almost entirely independent of the food, that the normal constituents of fat make their appearance as usual, though some of them may wholly be absent in the food, and that abnormal fats presented as food are not to be found in the fat which is stored up in the body as a consequence of a large supply of that food.

Subbotin, after starving a dog till he had reason to think all fat had disappeared from the body, fed it largely on palm-oil (containing palmitin and olein but no stearin) and the very leanest meat. The composition of the fat which was stored up during this diet is shewn in column 2, the normal constitution of the fat of a dog being shewn in column 1. Another dog, after a similar removal of the natural fat by starvation, was fed on meat and a soap composed of palmitic and stearic acids. The animal in this case received no olein. Yet the composition of his fat was that given in column 3.

	1.		2.			3.	
	A.	B.	A.	B.	C.	A.	B.
Palmitin	44·87	39·72	50·80	53·30	55·36	52·80	53·60
Stearin	19·23	32·48	9·00	13·20	13·24	13·20	13·40
Olein	35·90	27·80	40·20	33·50	30·80	34·00	33·00

A signifies the subcutaneous, B the mesenteric, and C the suprarenal adipose tissue.

Moreover, when a dog was fed, after a preliminary starvation period, with 1 kgm. of spermaceti, of which he was found to absorb at least 800 grms., nothing more than a trace of the spermaceti was to be found in his fat.

Of course it is quite possible that in such cases as these, though the stearin, or the olein, when absent from the food, was in some way or other constructed anew, yet at the same time those con-

¹ *Zt. f. Biol.* vi. (1870) p. 73.

stituents which were present were simply stored up; but it is also open for us to suppose that all the fat taken as food was in some way or other disposed of, and that all the new fat which made its appearance was constructed anew. And the latter view is supported by the histological facts mentioned above (p. 340), as well as by other considerations, which we shall presently have to urge. At the present, however, we may be content with the following conclusions. 1. Fat is formed anew in the animal body. 2. The carbon elements of the newly-formed fat may be supplied either from amylaceous food, or from the carbon surplus of proteid food, or from fats taken as food which are not the natural constituents of the body-fat. 3. The fat stored up appears as fat granules or drops deposited in the protoplasm of certain cells, and the increase of the fat in the cells is accompanied first by a growth, and subsequently by a decay of the protoplasm; but there is no complete evidence to shew whether the fat-granules which appear are simply deposited by the protoplasm in a more or less mechanical manner, without their forming an integral portion of it, or whether they arise from a breaking up, a functional metabolism of the protoplasm itself.

The question touched on here is one the solution of which is probably still far distant. We know that protoplasm such as that of *Penicillium*¹ can build itself up out of ammonium tartrate and inorganic salts, and can by a decomposition of itself give rise to fats and other bodies; and we have every reason to suppose that this constructive power belongs naturally to all native protoplasm wherever found. At the same time, we see that even in *Penicillium* it is of advantage to offer to the protoplasm as food, substances such as sugar and proteids (peptone) which are, so to speak, already on the way to become protoplasm; the organism is thus saved much constructive labour. And we may imagine that a cell would always take and assimilate into itself already constructed fats, sugar, proteids, &c., rather than have the preliminary trouble of building up these substances out of simpler compounds. But when we consider how in every being, every cell and every part of a cell has its own individual characters, stamped on it by long hereditary action, we see a reason why every bit of protoplasm, especially in the higher more differentiated organisms, should be made anew. And the energy required for the construction is always at hand. The food, which, instead of being directly assimilated without loss of energy, is reduced to simple compounds, sets free an energy which remains available for reconstruction. Of course in every such decomposition and recomposition there will be an irrecoverable loss in the form of heat which escapes; but, as we know, the whole of animal life is arranged with a view to this continual loss. It is not therefore so unreasonable as at first sight appears, to suppose that the animal protoplasm is as constructive as the vegetable protoplasm, the difference between the two being that the former, unlike the latter, is as destructive as it is constructive, and therefore requires to be continually fed with ready constructed material.

¹ Huxley and Martin, *Elementary Biology*, Lesson v.

The Mammary Gland.

Although milk is a secretion, and indeed an excretion, although therefore the mammary gland cannot be classed as a metabolic tissue, in the limited meaning we are now attaching to those words, yet the metabolic phenomena giving rise to the secretion are so marked and distinct, and have so many analogies with the metabolic events in adipose tissue, that it will be more convenient to consider the matter here, rather than in what would seem its more proper place.

Human milk has a specific gravity of from 1·028 to 1·034, and when quite fresh possesses a slightly alkaline reaction. It speedily becomes acid, and cow's milk, even when quite fresh, is sometimes slightly acid, the change of reaction taking place during the stagnation of the milk in the mammary ducts.

The **constituents** of milk are :

1. Proteids, viz. casein, and an albumin, agreeing in its general features with ordinary serum-albumin. The casein may be thrown down by the careful addition of acetic acid; but the most complete precipitation is effected by first adding to the milk a slight quantity of acetic acid, and then passing through it a stream of carbonic acid. From the filtrate the serum-albumin, which is present in small and variable quantities, may be obtained by coagulation with heat, or by precipitation with potassium ferrocyanide, &c.

2. Fats. These are palmitin, stearin and olein.

There are present also, to the extent of about 2 per cent. of the total fat, the glycerides of butyric, capronic, caprylic, and myristinic acids.

3. Milk-sugar, the conversion of which into lactic acid gives rise to many of the features of milk.

4. Extractives, including, according to some observers, urea, and salts. The last consist chiefly of potassium phosphate, with calcium phosphate, potassium chloride, small quantities of magnesium phosphate and traces of iron.

The following is the composition of 1000 parts of

	Human Milk.	Cow's Milk.
Casein	39·24	48·28
Albumin	—	5·76
Fat	26·66	43·05
Sugar	43·64	40·37
Salts	1·38	5·48
Total Solids	110·92	142·94
Water	889·08	857·06

Milk is an emulsion, the fats existing in the form of globules of various but minute size, each protected by a thin envelope of casein or albumin. It is this condition of the fat which gives to milk its peculiar white colour. The *colostrum*, or secretion of the mammary

gland at the beginning of lactation, differs from milk in being very deficient in casein and proportionately rich in albumin. It is said that the milk at the end of a long lactation again becomes poor in casein and rich in albumin. Milk on standing turns sour and curdles. This is due to the milk-sugar becoming converted by a fermentative process into lactic acid, which in turn precipitates the casein. The change may be rapidly brought about by means of a ferment contained in the gastric membrane. (See p. 194.)

Milk, like the other secretions which we have studied, is the result of the activity of certain protoplasmic secreting cells forming the epithelium of the mammary gland. As far as the fat of milk is concerned, the processes taking place in the gland are very instructive, since the fat can be *seen* to be gathered in the epithelium cell, in the same way as in a fat-cell of the adipose tissue, and to be discharged into the channels of the gland, either by a breaking up of the cells, or by a contractile extrusion very similar to that which takes place when an amœba ejects its digested food. All the evidence we possess goes to prove that the fat is formed in the cell through a metabolism of the protoplasm. The microscopic history is thoroughly supported by other facts. Thus the quantity of fat present in milk is largely and directly increased by proteid, but not increased, on the contrary diminished, by fatty food¹. This is quite intelligible when we know, as will be shewn in a succeeding section, that proteid food increases, and fatty food diminishes, the metabolism of the body; and we have already discussed the manner in which proteid material may give rise to fat. A bitch fed on meat for a given period gave off more fat in her milk than she could possibly have taken in her food, and that too while she was gaining in weight, so that she could not have supplied the mammary gland with fat at the expense of fat previously existing in her body. In the 'ripening' of cheese we have a similar conversion of proteids into fat. We have also evidence that the casein is, like the fat, formed in the gland itself. When milk is kept at 35 degrees C. out of the body the casein is increased at the expense of the albumin. When the action of the cell is imperfect, as at the beginning or end of lactation, the albumin is in excess of the casein; but as long as the cell possesses its proper activity the formation of casein becomes prominent. It has been suggested that the casein may be formed by a splitting up of albumin by some fermentative process, but no such ferment has yet been isolated. That the milk-sugar also is formed in and by the protoplasm of the cell, is indicated by the fact that the sugar is not dependent on carbohydrate food, and is maintained in abundance in the milk of carnivora when these are fed exclusively on meat, as free as possible from any kind of sugar or glycogen. We thus have evidence in the mammary gland of the formation, by the direct metabolic activity of the secreting cell, of

¹ Subbotin and Kemmerich, *Cbl. Med. Wiss.* 1866, p. 337.

the representatives of the three great classes of food-stuffs, proteids, fats and carbohydrates, out of the comprehensive substance protoplasm. And what we see taking place in the mammary cell is probably a picture of what is going on in all protoplasmic bodies. If the fat of the milk were not ejected from the mammary cell, the mammary gland would become a mass of adipose tissue, especially if, by a slight change in the metabolism, the production of fat were exalted at the expense of the production of casein or milk-sugar. If, again, by a similar slight change the milk-sugar were accumulated rather than the fat or proteid, we should have a result which, by an easy step, would bring us to glycogenic tissue. And, lastly, if the proteid accumulation were greater than the fatty, or the saccharine, these being carried off in some way or other, we should have an image of the nutrition of an ordinary nitrogenous tissue.

That both the secretion and ejection of milk are under the control of the nervous system is shewn by common experience, but the exact nervous mechanism has not yet been fully worked out. While erection of the nipple ceases when the spinal nerves which supply the breast are divided, the secretion continues, and is not arrested even when the sympathetic as well as the spinal nerves are cut¹.

The Spleen.

The Spleen may be wholly removed from an animal without any obvious changes in the economy taking place; the functions of the rest of the body appear to go on unimpaired. We are obliged to assume that some compensating actions take place: but what those actions are we do not know, and we are left at present by these experiments almost completely in the dark as to the functions of the spleen. The most that has been observed is a slight increase in the lymphatic glands, and in the activity of the medulla of bones.

Schiff² maintains that after extirpation of the spleen, pancreatic juice is no longer able to digest proteids. He believes that the spleen during its turgescence manufactures a substance, which being carried to the pancreas, gives rise by a kind of ferment action of its own to the pancreatic proteolytic ferment. In the language of Heidenhain's results, the presence of the splenic product is necessary for the conversion of the zymogen into the pancreatic proteolytic ferment. Herzen³ further states that in the exceptional cases where the spleen does not become turgid during digestion, the pancreatic juice is inert towards proteids. The evidence in favour of this action of the spleen is, at present, not cogent, and Mosler⁴ denies that extirpation of the spleen has any influence whatever over either gastric or pancreatic digestion.

After a meal the spleen increases in size, reaching its maximum

¹ Eckhard, *Beiträge*, I. and VIII. (1877) p. 117. Röhrig, *Virchow's Archiv*, LXVII. (1876) p. 119.

² *Schweiz. Zt. f. Heilk.* I. (1862) p. 209. See also *Leçons sur la Digestion*.

³ *Cbt. f. Med. Wiss.* 1877, p. 435.

⁴ *Cbt. f. Med. Wiss.* 1871, p. 290.

about five hours after the taking of food; it remains swollen for some time, and then returns to its normal bulk. In certain diseases, such as in the pyrexia attendant on fevers or inflammations, and more especially in ague, a similar temporary enlargement takes place. In prolonged ague a permanent hypertrophy of the spleen, the so-called ague-cake, occurs.

The turgescence of the spleen seems to be due to a relaxation both of the small arteries and of the muscular bands of the trabeculæ; to be, in fact, a vaso-motor dilation accompanied by a local inhibition of the tonic contraction of the other plain muscular fibres entering into the structure of the organ. And the condition of the spleen, like that of other vascular areas, appears to be regulated by the central nervous system, the digestive turgescence being altogether comparable to the flushed condition of the pancreas and the gastric membrane during their phases of activity.

According to Tarchanoff¹ section of the splenic nerves causes a turgescence lasting for some time, but disappearing in the course of a few days. Stimulation of the spinal cord causes a shrinking, which, however, fails to make its appearance if the splanchnic nerves be previously divided. The shrinking or constriction may be brought about in a reflex manner by stimulation of the central stump of the sciatic nerve. The effect, however, is in the case of this nerve slight, whereas if the central stump of the vagus be stimulated, a very marked shrinking is observed. Local stimulation causes local shrinking; if the electrodes of an interrupted current be drawn across a turgid spleen, their course is marked by a white line of constriction lasting for some little time. Contraction of the spleen is also caused by quinine and strychnia.

This functional intermittent turgescence, so clearly related to the ingestion of food, may be connected with that manufacture of white corpuscles and destruction of red corpuscles of the blood, of which we spoke in an early chapter (p. 29); but when the peculiar arrangements of the blood-vessels of the spleen, with their large open venous networks, are borne in mind, it seems in the highest degree probable that metabolic events of great importance (possibly associated in some way with the metamorphosis of the blood-corpuscles) take place in the spleen, though at present we are unable to follow them. And this view is supported by the somewhat peculiar chemical characters of the spleen-pulp, which, in spite of its containing a very large number of blood-corpuscles, differs markedly in its chemical composition from either blood or serum. Thus a special proteid of the nature of alkali-albumin seems to be present, holding iron in some way peculiarly associated with it. The occurrence of this ferruginous proteid, accompanied as it is by several peculiar but at present little understood pigments, rich in carbon, bears out the histological conclusions concerning the disappearance of the red corpuscles. The inorganic salts of the spleen, or at least

¹ Pfüger's *Archiv*, VIII. (1874) 97.

those of its ash, are remarkable for the large amount of both soda and phosphates, and the scantiness of the potash and chlorides which they contain, thus differing from blood-corpuscles on the one hand, and from blood-serum on the other. But perhaps the most striking feature of the spleen-pulp is its richness in the so-called extractives. Of these the most common and plentiful are succinic, formic, acetic, butyric and lactic acids (these may arise in part from the decomposition of hæmoglobin), inosit, leucin, xanthin, hypoxanthin and uric acid. Tyrosin apparently is not present in the perfectly fresh spleen, though leucin is: both are present after decomposition has set in. The constant presence of uric acid is remarkable, especially since it has been found even in the spleen of animals, such as the herbivora, whose urine contains none. No less suggestive is the fact that the increase of uric acid in the urine during ague, and during ordinary pyrexia, seems to run parallel to the turgescence, and therefore presumably to the activity, of the spleen. But these facts are at present suggestive only; they point to an active metabolism associated with digestion taking place in the spleen; exact information as to the nature of the metabolism is however wanting. The thyroid and thymus bodies, often in descriptions associated with the spleen, though different in structure, the former entirely so, resemble the spleen somewhat, as far as their extractives are concerned. The thymus contains leucin, xanthin and hypoxanthin, with lactic and succinic acids; uric acid seems to be absent. The extractives of the thyroid are scanty, but apparently of the same nature.

SEC. 2. THE HISTORY OF UREA AND ITS ALLIES.

We may now return to the questions which we left unanswered at p. 327, Where is urea formed? what are its immediate antecedents? what are the various chemical links between it and the proteid material of which it is the excretory representative?

We have seen, p. 34, that the muscular tissues contain kreatin, together with smaller quantities of allied nitrogenous crystalline bodies, such as xanthin, hypoxanthin, &c.; and we cannot go far wrong in supposing that these bodies are in some way or other the products of muscular metabolism. We do not know in what quantities they are formed; but since they are such bodies as would readily be carried away from the muscle by the blood-stream, and yet are always to be found in the muscle, we infer that they are continually being formed, and as continually being converted into some other bodies and carried away. And we may further say, that since kreatin exists in muscle to the extent of $\cdot 2$ or $\cdot 4$ p. c., and since muscle forms so large a portion of the whole body, it is at least possible, if not probable, that a considerable amount of kreatin passes within twenty-four hours into the blood, on its way to become transformed by other tissues into urea, or into some stage nearer to urea than itself.

The urine contains a certain amount (.9 gm. in 24 hours) of kreatin, or kreatinin, into which kreatin is easily converted; but neither of these can be considered as the normal channel by which the kreatin formed in the muscles passes out of the body. For the urinary kreatin is exceedingly variable in quantity, vanishes during starvation, and, though not at all increased by exercise, is largely augmented by a flesh-diet¹; and kreatin injected into the blood, even in small quantities, reappears unchanged in the urine. Without laying too much stress on the last fact, we are led to conclude that the kreatin or kreatinin in urine has an origin quite independent of that which is present in the muscles, being probably derived directly from the food.

With regard to the substances, such as xanthin, which appear in muscle in small quantities only, our information is too imperfect to allow us to make any statement whatever about them.

While then we have some reason for thinking that the kreatin found, and presumably formed, in muscle is a more or less distant antecedent of urea, it must be remembered that this is simply a more or less probable view, not an ascertained or clearly proven fact.

Of the metabolism of the nervous tissues we know little; but kreatin is found in the brain, in some cases in not inconsiderable quantity. Now the bodies of the nerve-cells are undoubtedly composed of protoplasm; the axis-cylinders of the nerve-fibres are also protoplasmic in nature, and it is at least possible that much of the peculiar matrix of the cerebral and cerebellar convolutions, and of the grey matter generally, is also in reality protoplasmic. Hence we may, with a certain amount of reason, suppose that the nervous, like the muscular tissues, are continually, but to a much less extent, supplying an antecedent to urea in the form of kreatin.

Lastly, the spleen contains a considerable quantity of kreatin, as well as of xanthin, &c.; and these are present also in various glandular organs.

We thus have evidence of a continual formation of kreatin, possibly in large quantities, in various parts of the body. On the other hand, urea is certainly not present in muscle (save in certain exceptional cases) and its presence in nervous tissue is extremely doubtful. It is absent from the spleen (of the occurrence of urea in the liver we shall speak presently), the thymus, and thyroid bodies, and from the lymphatic glands, though uric acid, as we have seen, appears to be a normal constituent of the spleen. It seems very tempting to jump at once from these facts to the conclusion that kreatin is the natural antecedent of urea, and that as far as nitrogenous excretion is concerned the labour of the kidney is confined to the simple transformation of kreatin into urea. We have only to suppose that the kreatin passes from these several tissues into the blood, in which it may be found, and while circulating in the blood is seized upon by the renal epithelium and converted into urea. And there are some facts which support this view. But there are others which

¹ Voit, *Zt. f. Biol.* iv. 77.

oppose it; and while it cannot be said to be wholly disproved, it cannot at present be accepted as sufficiently satisfactory to serve as a foundation for other arguments.

In the first place, urea, in spite of its absence from the muscles and other tissues, is always present in the blood, and has also been found in the chyle, in the serous fluids, and in saliva. It might be urged of course that this urea is, so to speak, an overflow from the kidney, that owing to its great diffusibility it has passed back from the renal epithelium where it was manufactured into the blood-stream. When, however, we reflect how all diffusion is overborne by the natural physiological currents, as shewn indeed by the absence of urea from muscle, in spite of its presence in the blood, this argument loses all the little force it had.

In certain diseases of the kidney, the excretion of urine ceases. This suppression of urine, as it is called, is followed by an accumulation of urea in the blood and all parts of the body, and is accompanied by symptoms known as those of uræmic poisoning, though the toxic consequences are due not to the presence in the system of the large quantity of urea, but of other, at present undefined, substances which have at the same time ceased to be excreted. Oppler¹ and Zalesky stated that when the kidneys of an animal were extirpated, or the renal arteries ligatured, though uræmic symptoms set in as usual, there was no accumulation of urea in the blood or tissues, and no excess of carbonic acid or ammonium carbonate, such as might have arisen from a rapid decomposition of urea. There was however a marked accumulation of kreatin or of kreatinin. On the other hand, these observers found that when the ureters were ligatured, so that the blood was still brought under the influence of the renal epithelium, and yet the products of the activity of that epithelium not allowed to escape, an accumulation of urea (in birds of uric acid) and not of kreatin was observed. These results, if indisputable, would indeed afford strong evidence of the conversion of kreatin into urea by the agency of the renal epithelium. They have however been much disputed. Thus Gréhant², using what was probably a better method for the estimation of urea, (and the detection of urea in complex organic fluids is subject to very considerable errors,) came to the conclusion that the urea in the blood, after extirpation of both kidneys, rose from ·026 and from ·088 to ·206 and ·276 per cent. in 24 and 27 hours respectively. And Gscheidlen³ has come to a similar conclusion. The results according to both these latter observers are the same whether the kidneys are extirpated or the ureters tied; in the latter case the distension of the tubules soon renders the epithelium cells incapable of performing their functions, and thus an animal, in which the ureters have been ligatured, is practically in the same condition as one from which the kidneys have been removed. Neither Gréhant nor Gscheidlen make any statement about an increase of kreatin. And it may be worth while to notice that though the experiments of these observers prove that *all* the urea of the urine is certainly not formed in the kidney, they do not necessarily oppose the view that *some* of it may be so formed out of kreatin or some similar antecedent. Nor is there anything *à priori* to contradict the supposition that the origin of urea may be double, part being formed in one

¹ Virchow's *Archiv*, xxi. 260.

² *Cbt. Med. Wiss.* 1870, p. 249.

³ *Studien ü. d. Ursprung d. Harnstoffs.* Leipzig, 1871.

way and part in another. Lastly, the fact that urea injected into the blood causes a rapid secretion of urine, may be used as an argument that the habit of the renal epithelium is to pick out, so to speak, the urea from the blood and to carry it into the channels of the renal tubules.

There is moreover another possible source of urea besides the kreatin formed in muscle and elsewhere. We have seen that one result of the action of the pancreatic juice is the formation of considerable quantities of leucin and tyrosin. In dealing with the statistics of nutrition, our attention will be drawn to the fact that the introduction of proteid matter into the alimentary canal is followed by a large and rapid excretion of urea, suggesting the idea that a certain part of the total quantity of the urea normally secreted comes from a direct metabolism of the proteids of the food, without these really forming a part of the tissues of the body. We do not know to what extent normal pancreatic digestion has for its product leucin, and its companion tyrosin; but if, especially when a meal rich in proteids has been taken, a considerable quantity of leucin is formed, we can perceive an easy and direct source of urea, provided that the metabolism of the body is capable of converting leucin into urea. That the body can effect this change is shewn by the fact that leucin, when introduced into the alimentary canal in even large quantities, does reappear in the urine as urea; that is, the urine contains no leucin, but its urea is proportionately increased; and the same is probably the case with tyrosin, though this is disputed. Now the leucin formed in the alimentary canal is carried by the portal blood straight to the liver; and the liver, unlike other glandular organs, does, even in a perfectly normal state of things, contain urea. We are thus led to the view that among the numerous metabolic events which occur in the hepatic cells, the formation of urea out of leucin or out of other antecedents may be ranked as one. Probable, however, as this view may seem, it has not as yet been established as a fact.

Meissner¹ found a large quantity of urea in the liver of mammals, and of urates in the liver of birds. Cyon² attempted to demonstrate the formation of urea in the liver by passing a stream of fresh blood through the liver of an animal recently killed, and estimating the percentage of urea in the blood used before and after. He found it to be increased from ·08 to ·176. This however is not conclusive, for, as Gscheidlen has urged³, the increased quantity in the blood which had been circulated was simply urea which had been washed out from the liver, where it had previously been staying. A strong presumption in favour of urea arising through the hepatic metabolism, from leucin as an antecedent, is afforded by the fact that in cases of acute atrophy of the liver, where the hepatic cells lose their functional activity, the urea of the urine is replaced by leucin and tyrosin. And lastly, it may be remarked that not only are leucin and tyrosin found in nearly all the tissues after death, especially in the glandular tissues, but they also appear with striking readiness in almost

¹ *Zt. f. rat. Med.* (3) xxxi. 144.

² *Chit. f. Med. Wiss.* 1870, p. 580.

³ Cf. also Munk, *Pflüger's Archiv*, xi. (1875) p. 100.

all decompositions of proteid, and, in the case of the former, of gelatiniferous substances.

The view that leucin is transformed into urea lands us however in very considerable difficulties. Leucin, as we know, is amido-caproic acid; and, with our present chemical knowledge, we can conceive of no other way in which leucin can be converted into urea than by the complete reduction of the former to the ammonia condition, and a reconstruction of the latter out of the ammonia so formed. We have a somewhat parallel case in glycine. This, which is amido-acetic acid, when introduced into the alimentary canal, also reappears as urea; here too, a reconstruction of urea out of an ammonia phase must take place¹. And there are some recent facts which point in exactly the same direction, viz. in a derivation of the normal urea of the urine from a simple ammonia antecedent. O. Schultzen² finds that when an appropriate quantity of sarcosin is given by the mouth, urea disappears from the urine, being replaced by a compound of sarcosin and carbamic acid (in company with a compound of sarcosin with sulphamic acid). The interpretation of this result is that in normal metabolism the proteids are ultimately broken down to carbamic acid and ammonia, which unite and becoming subsequently dehydrated, form urea; thus $\text{CO}_2\text{N}_2\text{H}_6$ ammonium carbamate - $\text{H}_2\text{O} = \text{CON}_2\text{H}_4$ urea; but that carbamic acid, having a greater affinity for sarcosin than ammonia, seizes the former in preference when it is at hand, and consequently gives rise to Schultzen's compound. There are however many difficulties in accepting this view. In the first place, no compounds of carbamic acid are known to exist in the blood or in the body³: this however perhaps is an objection of no great validity. In the second place, sarcosin, though not apparently a normal constituent of any of the tissues, should, if kreatin is normally converted into urea, arise somewhere in the body constantly as a bye-product of that conversion, since kreatin contains residues of both urea and sarcosin. Schultzen's compound therefore ought to be a normal constituent of the urine, which apparently it is not. Nevertheless there remain the facts, that leucin is in some way or other converted, in the body, into urea; that leucin, since it occurs abundantly in the body, is probably a source of part of the urea; and that leucin can only be converted into urea by a decomposition into ammonia or an ammonia body, whereby the caproic acid residue is set free either to be elaborated into a fat or to be oxidized into carbonic acid. It is worthy of notice that this idea of a reconstruction of urea out of ammonia agrees completely with the views expressed on p. 343 concerning the constructive capacities of the animal organism.

To sum up our imperfect knowledge concerning the history of urea. We have evidence, not exactly complete but fairly satisfactory, that a part at least of the urea is simply withdrawn from the blood by the renal epithelium. The activity of the protoplasm of the secreting cells must therefore, as far as this part of the urea is concerned, be confined to absorbing the urea from the renal blood, and to passing it on into the cavities of the renal tubules. The mechanism by which this is effected we cannot at present fathom, but it seems

¹ Cf. Salkowski, *Zt. f. Physiolog. Chem.* 1. (1877) 1. Schmiedeberg, *Archiv f. Exp. Path.* viii. (1877).

² *Berichte Deut. Chem. Gesell.* 1872, p. 578.

³ Cf. Drechsel, *Ludwig's Arbeiten*, 1875. Hofmeister, *Pflüger's Archiv*, xii. (1876) p. 337.

more comparable to a selection of food than to anything else; the cells appear to treat urea much in the same way as they treat indigo-carmin (p. 325). The antecedents of the urea in the blood are, we may at present suppose, partly the kreatin formed in muscle and elsewhere, partly the leucin and other like bodies formed in the alimentary canal as well as in various tissues. The transformation of these bodies into urea may take place in the liver (and spleen), but we have no exact proof of this, nor can we say exactly in what way the transformation is effected. There is no proof of any body existing in the blood capable of effecting this transformation; and we may probably rest assured that in this, as in other metabolic events, the activity exercised in the change comes from some tissue, and cannot be manifested by simple blood plasma.

Lastly, it is possible that the kidney may, besides the simpler duty of withdrawing ready formed urea from the blood, be exercised in transforming various nitrogenous crystalline bodies to serve as part of the supply of urea which passes from it.

Uric Acid. This, like urea, is a normal constituent of urine, and, like urea, has been found in the blood, and in the liver and spleen; we have already, p. 348, referred to its relations with this latter organ. In some animals, such as birds and most reptiles, it takes the place of urea. In various diseases the quantity¹ in the urine is increased; and at times, as in gout, uric acid accumulates in the blood, and is deposited in the tissues. By oxidation a molecule of uric acid can be split up into two molecules of urea and a molecule of mesoxalic acid. It may therefore be spoken of as a less oxidized product of proteid metabolism than urea; but there is no evidence whatever to shew that the former is a necessary antecedent of the latter; on the contrary, all the facts known go to shew that the appearance of uric acid is the result of a metabolism slightly diverging from that leading to urea. And we have no evidence to prove that the cause of the divergence lies in an insufficient supply of oxygen to the organism at large; on the contrary, uric acid occurs in the rapidly breathing birds, as well as in the more torpid reptiles. It has been urged² that birds, though breathing with great energy, yet consume oxygen to such an extent that in spite of their income they are always in lack of it; but of this there is no proof, while the richness of their blood in red corpuscles points in the opposite direction. Nor can the fact that in the frog urea again replaces uric acid be explained by reference to that animal having so large a cutaneous in addition to its pulmonary respiration. The final causes of the divergence are to be sought rather in the fact that urea is the form adapted to a fluid, and uric acid to a more solid excrement.

¹ It need hardly be pointed out that an increase in the quantity of uric acid in the urine must be distinguished from an increase in the prominence of uric acid due to the precipitation of its alkaline salts.

² Odling, *Lectures on Animal Chemistry*, p. 144.

Hippuric Acid. In the urine of herbivora uric acid is for the most part absent, being replaced by hippuric acid. In the urine of omnivorous man, both acids may be present together. The history of the hippuric acid of urine is very instructive; for though at first sight its presence might appear to indicate that the metabolism of the herbivora is in some points fundamentally different from that of carnivora, there can be little doubt that the hippuric acid which appears in the urine of herbivora comes directly from the ingested food. Hippuric acid is a compound of benzoic acid and glycin; and when benzoic acid is introduced into the stomach of an animal, whether herbivorous or not, it reappears not as benzoic but as hippuric acid. If previous to the injection the liver be excised, the benzoic acid passes out through the urine unchanged¹. If the benzoic acid be injected slowly into the portal vein, it issues as hippuric acid; if it be injected into the jugular, especially if it be injected rapidly, the greater portion passes out by the urine as unchanged benzoic acid. The explanation of these facts is obvious. The benzoic acid coming to the hepatic cells in the portal blood, meets there with a certain quantity of glycin; with this it unites and thus becomes hippuric acid. Nitrobenzoic acid in a similar way becomes nitrohippuric acid, and many other bodies, by a like assumption of glycin, become conjugated in their passage through the body. And it will be remembered that the two bile acids are conjugates of cholalic acid with glycin and taurin respectively. Now taurin is found in other tissues besides the liver, *ex. gr.* in muscles and in the lungs; but glycin is not found preformed in any tissue, though it is readily obtained by the decomposition of proteids and of gelatine. It appears however from the experiments just quoted that the conjugation with glycin can take place only in the liver; there must therefore be disposable glycin always present in the liver; yet it is not found in that organ in a free state. From this we learn in the first place that the absence of a body in a free state from any tissue is no proof that the body may not be habitually formed in that tissue; and in the second place, that the conjugation with glycin is the result of some activity of the hepatic cells of such a kind that the glycin is produced in such quantities only as are wanted; it is never present in excess, and so can never become free.

Meissner and Shepard² however maintained that the transformation of benzoic into hippuric acid took place not so much in the liver as in the kidney; and Bunge and Schmiedeberg³ have brought forward experimental evidence to the same effect.

The knowledge of the fact that benzoic acid is thus converted into hippuric acid naturally suggested the idea that the food of herbivora might contain either benzoic acid, or some allied body, and that the presence of hippuric acid as a normal constituent of urine

¹ Kühne u. Hallwachs. Virchow's *Archiv*, XII. (1857) 386.

² *Die Hippursäure*, Hannover, 1866.

³ *Archiv. f. Exp. Pathol.* VI. (1876) 233.

might be thus accounted for. And Meissner and Shepard¹ have shewn that all the hippuric acid of herbivorous urine is in reality due to the presence in ordinary fodder (hay) of a particular constituent containing a benzoic residue; when this constituent is withdrawn, the hippuric acid disappears from the urine. They regarded this substance as a particular form of cellulose; but this does not seem certain².

Of the meaning of the appearance in the tissues of such bodies as xanthin, &c. and of the exact nature of the metabolism which they undergo, we know nothing. We cannot say whether they are simply the accidental bye-products of nitrogenous metabolism, the result of imperfect chemical machinery; or whether they, though small in quantity, serve some special ends in the economy.

SEC. 3. THE STATISTICS OF NUTRITION.

The preceding sections have shewn us how wholly impossible it is at present to master the metabolic phenomena of the body by attempting to trace out forwards or backwards the several changes undergone by the individual constituents of the food, the body or the waste products. Another method is however open to us, the statistical method. We may ascertain the total income and the total expenditure of the body during a given period, and by comparing the two may be able to draw conclusions concerning the changes which must have taken place in the body while the income was being converted into the outcome. Many researches have of late years been carried out by this method; but valuable as are the results which have been thereby gained, they must be received with caution, since in this method of inquiry a small error in the data may, in the process of calculation and inference, lead to most wrong conclusions. The great use of such inquiries is to suggest ideas, but the views to which they give rise need to be verified in other ways before they can acquire real worth.

Composition of the Animal Body. The first datum we require is a knowledge of the composition of the body, as far as the relative proportion of the various tissues is concerned. In the human body, according to E. Bischoff³, the chief tissues are found in the following proportions by weight:

	Adult man (aged 33).	New-born baby (boy).
Skeleton	15·9 p. c.	17·7 p. c.
Muscles	41·8 "	22·9 "
Thoracic viscera	1·7 "	3·0 "
Abdominal viscera	7·2 "	11·5 "
Fat	18·2 "	} 20·0 "
Skin	6·9 "	
Brain	1·9 "	

¹ *Op. cit.*

² Cf. Weiske, *Zt. f. Biol.* xii. (1876) p. 241.

³ Quoted by Ranke, *Grundzüge*, p. 143.

An analysis of a cat gave Bidder and Schmidt¹ the following:

Muscles and tendons	45.0 p. c.
Bones	14.7 "
Skin	12.0 "
Mesentery and adipose tissue	3.8 "
Liver	4.8 "
Blood (escaping at death)	6.0 "
Other organs and tissues	13.7 "

One point of importance to be noticed in these analyses is that the skeletal muscles form nearly half the body; and we have already seen (p. 31) that about a quarter of the total blood in the body is contained in them. We infer from this that a large part of the metabolism of the body is carried on in the muscles. Next to the muscles we must place the liver, for though far less in bulk than them, it is subject to more active metabolism, as shewn by the fact that it alone holds about a quarter of the whole blood.

The Starving Body. Before attempting to study the influence of food, it will be useful to ascertain what changes occur in a body when all food is withheld. Voit² found that a cat lost in a hunger period of 13 days 734 grammes of solid material, of which 248.8 were fat and 118.2 muscle, the remainder being derived from the other tissues. The percentage of dry solid matter lost by the more important tissues during the period was as follows:

Adipose tissue	97.0
Spleen	63.1
Liver	56.6
Muscles	30.2
Blood	17.6
Brain and spinal cord	0.0

Thus the loss during starvation fell most heavily on the fat, indeed nearly the whole of this disappeared. Next to the fat, the glandular organs, the tissues which we have seen to be eminently metabolic, suffered most. Then come the muscles, that is to say, the skeletal muscles, for the loss in the heart was very trifling; obviously this organ, on account of its importance in carrying on the work of the economy, was spared as much as possible; it was in fact fed on the rest of the body. The same remark applies to the brain and spinal cord; in order that life might be prolonged as much as possible, these important organs were nourished by material drawn from less noble organs and tissues. The blood suffered proportionally to the general body-waste, becoming gradually less in bulk but retaining the same specific gravity; of the total dry proteid constituents of the body 17.3 p. c. was lost, which agrees very closely with the 17.6 p. c.

¹ *Die Verdauungssäfte*, p. 329.

² *Zt. f. Biol.* II. (1866) 307.

lost by the blood. It is worthy of remark that the tissues in general became more watery than in health.

We may infer from these data the conclusions that metabolism is most active first in the adipose tissue, next in such metabolic tissues as the hepatic cells and spleen-pulp, then in the muscles, and so on; but these conclusions must be guarded by the reflection that because the *loss* of cardiac and nervous tissue was so small, we must not therefore infer that their *metabolism* was feeble; they may have undergone rapid metabolism, and yet have been preserved from loss of substance by their drawing upon other tissues for their material.

During this starvation-period, the urine contained in the form of urea (for, as we shall see, the other nitrogenous constituents of urine may for the most part be disregarded) 27·7 grammes of nitrogen. Now the amount of muscle which was lost during the period contained about 15·2 of nitrogen. Thus, more than half the nitrogen of the outcome during the starvation-period must have come ultimately from the metabolism of muscular tissue. This is an important fact of which we shall be able to make use hereafter. Bidder and Schmidt¹ came to the conclusion, from their observations on a starving cat, that the quantity of urea excreted per diem, in all but the earlier days of the inanition period, bore a fixed ratio to the body-weight. In the first two or three days of the period, the daily quantity of urea was much greater than this. They were thus led to distinguish two sources of urea: a quantity arising from the functional activity of the whole body, and therefore bearing a fixed ratio to the body-weight, and continuing until near the close of life; and a quantity arising from the amount of surplus nitrogenous or proteid material which happened to be stored up in the body at the commencement of the period, and which was rapidly got rid of. The latter they regarded as not entering distinctly into the composition of the tissues, but as, so to speak, floating capital, upon which each or any of the tissues could draw. They spoke of its direct metabolism as a *luxus consumption*. Bischoff and Voit², however, by means of more extended observations, concluded that though the urea of the first two or three days much exceeds that of the subsequent days of a starvation-period, no such fixed relation of urea to body-weight as that suggested by Bidder and Schmidt obtains; but that the quantity which is passed is directly dependent on the amount of proteid material present in the food during the days antecedent to the commencement of the starvation period. This question of a *luxus consumption* is one to which we shall frequently have to refer.

The Normal Diet. What is the proper diet for a given animal under given circumstances, can only be determined when the laws of nutrition are known. · Meanwhile it is necessary to gain an approximate idea of what may be considered as the normal diet for a body

¹ *Die Verdauungssäfte*, 1852.

² *Die Gesetze d. Ernährung des Fleischfressers*, 1860.

such as that of man under ordinary circumstances. This may be settled either by taking a very large average, or by determining exactly the conditions of a particular case. In the table below is given both the average result obtained by Moleschott¹ from a large number of public diets, and the diet on which Ranke² found himself in good health, neither losing nor gaining weight.

	Moleschott.	Ranke (weight 74 kilos).
Proteids	30	100
Fat	84	100
Amyloids	404	240
Salts	30	25
Water	2800	2600

Of these two diets, which agree in many respects, that of Ranke is probably the better one, since in public diets, from which Moleschott's table is drawn, the cheaper carbohydrates are used to the exclusion of the dearer fats.

Comparison of Income and Outcome.

Method. We have now to inquire how the elements of such a diet are distributed in the excreta, in order that, from the manner of the distribution, we may infer the nature of the intermediate stages which take place within the body. By comparing the ingesta with the excreta, we shall learn what elements have been retained in the body, and what elements appear in the excreta which were not present in the food; from these we may infer the changes which the body has undergone through the influence of the food.

In the first place, the real income must be distinguished from the apparent one by the subtraction of the fæces. We have seen that by far the greater part of the fæces is undigested matter, *i.e.* food which, though placed in the alimentary canal, has not really entered into the body. The share in the fæces taken up by matter which has been excreted from the blood by the alimentary canal, is so small that it may be neglected; certainly with regard to nitrogen, the whole quantity of this element, which is present in the fæces, may be regarded as indicating simply undigested nitrogenous matter.

In comparing the income and outcome of a given period great difficulty is often found in determining whether the fæces passed in the early days of the period belong to the income of the period, or are the remains of food taken before. The difficulty, however, is frequently lightened when the diet of the experimental period differs from the foregoing diet. Thus in the dog, the fæces of a bread diet may easily be distinguished from those of a meat diet.

The income, thus corrected, will consist of so much nitrogen, carbon, hydrogen, oxygen, sulphur, phosphorus, saline matters, and

¹ *Die Nahrungsmittel*, p. 216.

² *Tetanus*, p. 249; *Grundzüge*, p. 158.

water, contained in the proteids, fats, carbo-hydrates, salts, and water of the food, together with the oxygen absorbed by the lungs, skin, and alimentary canal. The outcome will consist of (1) the respiratory products of the lungs, skin, and alimentary canal, consisting chiefly of carbonic acid and water, with small quantities of hydrogen and carburetted hydrogen, these two latter coming exclusively from the alimentary canal; (2) of perspiration, consisting chiefly of water and salts, for we shall neglect the dubious excretion (see p. 313) of urea by the skin, and the other organic constituents of sweat amount to very little; and (3) of the urine, which contains practically all the nitrogen really excreted by the body, as well as a large quantity of saline matters, and of water. Where complete accuracy is required the total nitrogen of the urine ought to be determined; it is found, however, that no errors of serious importance arise when the urica alone, as determined by Liebig's method, is taken as the measure of the total quantity of nitrogen in the urine.

It has been and indeed still is debated whether the body may not suffer loss of nitrogen by other channels than by the urine. The balance of evidence seems distinctly against such a view. While Boussingault, Reiset and Barral found a deficiency in the urinary nitrogen as compared with that in the income, Bidder and Schmidt, Bischoff and Voit, Ranke, Henneberg and others came to a different conclusion, which is perhaps most clearly shewn in the observations of Voit on a pigeon¹.

Of these elements of the income and outcome, the nitrogen, the carbon, and the free oxygen of respiration are by far the most important. Since water is of use to the body for merely mechanical purposes, and not solely as food in the strict sense of the word, the hydrogen element becomes a dubious one; the sulphur of the proteids, and the phosphorus of the fats, are insignificant in amount; while the saline matters stand on a wholly different footing from the other parts of food, inasmuch as they are not sources of energy, and pass through the body with comparatively little change. The body-weight must of course be carefully ascertained at the beginning and at the end of the period, correction being made where possible for the fæces.

It will be seen that the labour of such inquiries is considerable. The urine, which must be carefully kept separate from the fæces, requires daily measurement and analysis. Any loss by the skin, either in the form of sweat, or, in the case of woolly animals, of hair, must be estimated or accounted for. The food of the period must be as far as possible uniform in character, in order that the analyses of specimens may serve faithfully for calculations involving the whole quantity of food taken; and this is especially the case when the diet is a meat one, since portions of meat differ so much from each other. But the greatest difficulty of all lies in the estimation of the carbonic acid produced and the oxygen consumed. In the earlier researches, such as those of Bischoff and Voit, this element was

¹ *Ann. Chem. Pharm. Suppl.* ii. 1863.

neglected and the variations occurring were simply guessed at, through which very serious errors were introduced. No comparison of income and outcome can be considered satisfactory unless the carbonic acid produced be directly measured by means of a respiration chamber.

Pettenkofer and Voit¹ were the first to make use on a large scale of this means of inquiry. Their apparatus consists essentially of a large air-tight chamber, capable of holding a man comfortably. By means of a steam engine a current of air, measured by a gasometer, is drawn through the chamber. Measured portions of the outgoing air are from time to time withdrawn and analysed; and from the data afforded by these analyses, the amount of carbonic acid (and other gases) given off by the occupant of the chamber during a given time is determined. The apparatus works so well that Pettenkofer and Voit were able almost exactly to recover the elements produced by the burning of a stearin candle in the chamber; the error did not amount to more than $\cdot 3$ per cent.

If the total amount of carbonic acid and water given out by the lungs be known, as well as the amount of urine and fæces, then the quantity of oxygen can be easily calculated. For evidently the difference between the terminal weight plus all the egesta and the initial weight plus all the ingesta can be nothing else than the weight of the oxygen absorbed during the period.

Let us imagine, then, an experiment of this kind to have been completely carried out, that the animal's initial and terminal weights have been accurately determined, the composition of the food satisfactorily known to consist of so much proteid, fat, carbohydrates, salts, and water, and to contain so much nitrogen and carbon, the weight of the fæces and the nitrogen they contain ascertained, the nitrogen of the urine determined, the carbonic acid given off by the whole body carefully measured, and the amount of oxygen absorbed calculated—what interpretation can be placed on the results?

Let us suppose that the animal has gained w in weight during the period. Of what does w consist? Is it fat or proteid material which has been laid on, or simply water which has been retained, or some of one and of the other? Let us further suppose that the nitrogen of the urine passed during the period is less, say by x grammes, than the nitrogen in the food taken, of course after deduction of the nitrogen in the fæces. This means that x grammes of nitrogen have been retained in the body; and we may with reason infer that they have been retained in the form of proteid material. We may even go farther and say that they are retained in the form of flesh, *i.e.* of muscle. In this inference we are going somewhat beyond our tether, for the nitrogen might be stored up as hepatic, or splenic, or any other form of protoplasm. Indeed it might be for the while retained in the form of some nitrogenous crystalline body; but this last event is unlikely; and if we use the word 'flesh' to mean protoplasm of

¹ *Ann. Chem. Pharm. Suppl.* ii. 1863.

any kind, contractile or metabolic, or of any other kind, we may without fear of error reckon the deficiency of x grammes nitrogen as indicating the storing up of a grammes flesh. There still remains $w - a$ grammes of increase to be accounted for. Let us suppose that the total carbon of the egesta has been found to be y grammes less than that of the ingesta; in other words, that y grammes of carbon have been stored up. Some carbon has been stored up in the flesh with the nitrogen just considered; this we must deduct from y , and we shall then have y' grammes of carbon to account for. Now there are only two principal forms in which carbon can be stored up in the body: as glycogen or as fat. The former is even in most favourable cases inconsiderable, and we therefore cannot err greatly if we consider the retention of y' grammes carbon as indicating the laying on of b grammes fat. If $a + b$ are found equal to w , then the whole change in the economy is known; if $w - (a + b)$ leaves a residue c , we infer that in addition to the laying on of flesh and fat some water has been retained in the system. If $w - (a + b)$ gives a negative quantity, then water must have been given off at the same time that flesh and fat were laid on. In a similar way the nature of a loss of weight can be ascertained, whether of flesh, or fat, or of water, and to what extent of each. The careful comparison, the debtor and creditor account of income and outcome, enables us, with the cautions rendered necessary by the assumptions just now mentioned, to infer the nature and extent of the bodily changes. The results thus gained ought of course to agree with the amount of oxygen consumed, and if an account is kept of the water, this also ought to tally with the conclusions arrived at concerning the retention and the reverse of water.

Having thus studied the method and seen its weakness as well as its strength, we may briefly review the results which have been obtained by its means.

Nitrogenous Metabolism. When a diet of lean meat, as free as possible from fat, is given to a dog, which has previously been deprived of food for some time, and whose body therefore is greatly deficient in flesh, it might be expected that the great mass of food would be at once stored up, and only a small quantity be immediately worked off as an additional quantity of urea, occasioned by the increased labour thrown on the economy by the very presence of the food. This however is not the case; the larger portion passes off as urea at once, and only a comparatively small quantity is retained. If the diet be continued, and we are supposing the meals given to be ample ones, the proportion of the nitrogen which is given off in the form of urea goes on increasing until at last a condition is established in which the nitrogen of the egesta exactly equals that of the ingesta. This condition, which is spoken of as nitrogenous equilibrium, is attained in dogs with an exclusively meat diet only when large quantities of food are given, and is not easily maintained for any length of time. The exact quantity of meat required to

attain nitrogenous equilibrium varies with the previous condition of the dog; it is frequently seen when 1500 or 1800 grms. of meat are given daily. Thus the most striking effect of a purely nitrogenous diet is largely to increase the nitrogenous metabolism of the body. This result can partly be explained by the fact that with the meat diet the consumption of oxygen is largely increased; in other words, that the oxidizing activity of the body is directly augmented by a meat diet. This in turn may be due in part to the fact that proteid food largely increases the number of the red corpuscles, and so augments the amount of oxygen with which the tissues are supplied; but probably other agencies are at work.

When nitrogenous equilibrium is established, it does not mean that a body-equilibrium is established, that the body-weight neither increases nor diminishes. On the contrary, when the meal necessary to balance the nitrogen is a large one, the body may gain in weight, and the increase is proved, both by calculation from the income and outcome, and by actual examination of the body, to be due to the laying on of fat. The amount so stored up may be far greater than can possibly be accounted for by any fat still adhering to the meat given as food. We are therefore driven to the conclusion that the proteid food is split into a urea moiety and a fatty moiety, that the urea moiety is at once discharged, and that such of the fat as is not made use of directly by the body is stored up as adipose tissue. And this disruption of the proteid food at the same time explains why the meat diet so largely and immediately increases the urea of the egesta. We have already pointed out that possibly this disruptive metabolism of proteids is largely carried on in the alimentary canal itself by the aid of the pancreatic juice; whether or to what extent other organs share in the action we do not at present know.

Voit and others with him speak in the most decided way of the proteids of the body as existing in two forms: organ-tissue proteid and circulating or blood proteid. They regard the former as entering into the formation of the tissues and undergoing functional metabolism, the latter as simply tarrying in the blood and undergoing a direct oxidative metabolism. It is of course the latter alone which suffers the *luxus* consumption. To these two Voit has been led to add a third, or intermediate proteid, *viz.* store or surplus proteid, which is more labile than tissue proteid and yet more stable than the circulating proteid. We have again and again insisted in the course of this work that the oxidations of the body take place not in the blood but in the tissues; and are consequently prepared to reject Voit's conclusions unless evidence of a strictly *positive* character can be offered in their favour. No such evidence however is forthcoming¹; the most that can be said in favour of them is that they afford an easy explanation of the phenomena of proteid metabolism; on the other hand, if we admit a large *luxus* consumption in the alimentary canal, the remaining phenomena can be explained without throwing on the tissues what may appear too heavy a metabolic task. And in speaking of the

¹ Cf. Hoppe-Seyler, *Pflüger's Archiv*, VII. (1873) 399.

metabolism of any tissue it must be remembered that the metabolic changes need not necessarily involve the so-called structural elements. A fat-cell may probably accumulate in and discharge from its protoplasm a considerable quantity of fat without the morphological relations of the cell undergoing any marked change; and we can readily imagine that a tissue may suffer partial disintegration and re-integration without any interference with its morphological framework. Our knowledge however of this matter is very imperfect; we know that when a muscle contracts it loses some of its substance, but we do not at all know which parts of the fibre bear the loss.

The characteristic metabolic effects of proteid food are shewn not only by these calculations of what is supposed to take place in the body, but also by direct analysis. Lawes and Gilbert¹ laboriously analysing the body of a pig, which had been fed on a known diet, and comparing the analysis with that of another pig of the same litter, killed at the time when the first was put on the fixed diet, found that of the dry nitrogenous material of the food only 7·34 p. c. was laid up as dry proteid material during the fattening period, though the amount of proteid food was low; in the sheep the increase was only 4·14 p. c.

The Effects of Fatty and of Carbohydrate Food. Unlike those of proteid food, the effects of fats and carbohydrates cannot be studied alone. When an animal is fed simply on non-nitrogenous food, death soon takes place; the food rapidly ceases to be digested, and starvation ensues. We can therefore only study the dietetic effects of these substances when taken in connection with proteid material.

When a small quantity of fat is taken, in company with a fixed moderate quantity of proteid material, the whole of the carbon of the food reappears in the egesta. No fat is stored up, some even of the previously existing fat of the body may be consumed. As the fat of the meal is increased, a point is soon reached at which carbon is retained in the body as fat. So also with starch or sugar. When the quantity of this is small, there is no retention of carbon; as soon however as it is increased beyond a certain limit, carbon is stored up in the form of fat or, to a smaller extent, as glycogen. Fats and carbohydrates therefore differ essentially from proteid food in that they are not distinctly provocative of metabolism. This is exceedingly well shewn in the results of Lawes and Gilbert, for in the pig previously mentioned 472 parts of fat were stored up for every 100 parts of fat in the food, and of the total dry non-nitrogenous food 21·2 p. c. was retained in the body as fat. No clearer proof than this could be afforded that fat is formed in the body out of something which is not fat.

Pettenkofer and Voit² came to the conclusion that, marked as was the difference between proteid and non-nitrogenous food as regards the in-

¹ *Phil. Trans.* 1859, Part 2.

² *Zt. f. Biol.* ix.

crease of metabolism, fat did nevertheless to a certain extent behave like proteids; when an excess of fat was given the consumption of carbon in the body was increased, so that only a portion (though a large portion) of the excess of fat in the food was stored up.

As one might imagine, the presence of fat or carbohydrates in the food was found to check proteid metabolism; nitrogenous equilibrium was established with a much less expenditure of proteid food. For instance, with a diet of 800 grms. meat and 150 grms. fat, the nitrogen in the egesta became equal to that in the ingesta in a dog, in whose case 1800 grms. meat would have to be given to produce the same result in the absence of fats or carbohydrates.

On the other hand, it was found, with a fixed quantity of fatty or carbohydrate food, an increase of the accompanying proteid led not to a storing up of the surplus carbon contained in the extra quantity of proteid, but to an increase in the consumption of carbon. Proteid food increases not only proteid but also non-nitrogenous metabolism. This explains how an excess of proteid food may, by the increase of metabolism, actually reduce the fat of the body, as is exemplified in the dietetic system known as that of Mr Banting. This is intelligible when we remember that proteid food largely increases the oxidations of the body.

There can be no doubt then that both a proteid diet and a carbohydrate diet may give rise to the formation of fat within the body. And the question which we have already (p. 342) partly discussed comes again before us, In what way is this fat so formed? Is the sugar, arising during digestion from the carbohydrate, converted by a series of fermentative changes into fat? or is the sugar directly consumed by the tissues in oxidative changes, by which means the fatty derivatives of the metabolized proteids are sheltered from oxidation and stored up as fat? What light does the statistical method throw on this vexed question? Weiske and Wildt¹ have attempted to settle it. They took two young pigs of the same litter; one they killed and analysed as a standard of comparison. The other they fed for six months on known food (chiefly potatoes) and then killed and analysed it. Supposing that the fattened pig had to start with the same composition as the other, they calculated that it had stored up 5.5 kilos of fat. During the six months it had consumed 14.3 kilos of proteid material, of which it had stored up 1.3 kilos and metabolized 13 kilos. On the supposition that the metabolism of this 13 kilos consisted in its being split up into a urea and a fatty moiety, about 6 kilos of fat would thus have been produced. In other words, more than the fat actually stored up *might* have come from the proteid of the food. This of course does not prove that this was its actual source; and on the other hand Lawes and Gilbert² found that in the case of two pigs fed *ad libitum* on Indian corn and

¹ *Zt. f. Biol.* x.

² "Sources of Fat of Animal Body." *Phil. Mag.* Dec. 1866. See also *Journ. Anat. and Phys.* xi. (1877) p. 577.

barley-meal respectively, as much as 40 per cent. of the fat produced and stored up in the body could not have come from the metabolized proteids of the food. In spite of the analogy of mammary metabolism (see p. 346), we may conclude that some fat may come direct from carbohydrate food.

Lawes and Gilbert urge very justly that Weiske and Wildt, in the experiment just quoted, did not use a sufficiently fattening diet, and in another experiment used too much nitrogen. They state that if a pig were fed on a rich barley-meal diet so that it doubled its weight in about eight or ten weeks, the amount of proteid metabolized, in spite of the diet being richer in proteid material than are potatoes, would probably be insufficient to account for the fat stored up. This question is from a dietetic point of view one of extreme importance; for if all stored fat does come from proteid food, then all fattening food must contain a due proportion of it.

We have at present no exact information concerning the nutritive differences between fats and carbohydrates, beyond the fact that in the final combustion of the two, while carbohydrates require sufficient oxygen only to combine with their carbon, there being already sufficient oxygen in the carbohydrate itself to form water with the hydrogen present, fats require in addition oxygen to burn off some of their hydrogen. Hence in herbivora a larger portion of the oxygen consumed reappears in the carbonic acid of the egesta, than in carnivora, where more of it leaves the body as formed water; the proportions of the oxygen in the carbonic acid expired to the oxygen consumed being on an average 90 p. c. in the former and 60 p. c. in the latter. When a herbivorous animal starves, it feeds on its own fat, and under these circumstances the oxygen proportion in the expired carbonic acid falls to the carnivorous standard. The carbohydrates are notably more digestible than the fats, but on the other hand the fats contain more potential energy in a given weight. As to the difference between starch and sugar, we know nothing very definite, and all carbohydrates seem to be converted into grape-sugar before entering into the blood. Lawes and Gilbert¹ found that cane-sugar was rather more fattening than starch.

The Effects of Gelatine Food. It is a matter of common experience that gelatine will not supply the place of proteids as a constituent of food. Animals fed on gelatine with fat or carbohydrates die very much in the same way as when they are fed on non-nitrogenous material alone. Nevertheless the researches of Voit² shew, as might be expected, that the presence of gelatine in food is not without effect. According to him nitrogenous equilibrium is established at a lower level of proteid food when gelatine is added. Thus the nitrogen of the ingesta and egesta became equal in a dog on a ration of 400 grms. proteid and 200 grms. gelatine. A dog moreover uses up less of the

¹ *Brit. Assoc. Reports*, 1854.

² *Zt. f. Biol.* VIII. 297.

nitrogen of the body on a diet of gelatine and fat, than on a diet of fat alone; and the consumption of fat also seems to be lessened by the presence of gelatine. All these facts become intelligible if we suppose that gelatine is rapidly split up into a uræa and a fat moiety, in the same way that we have seen a certain quantity of proteid material to be. It is this direct metabolism of proteid matter which gelatine can take up; it seems however unable to imitate the other function of proteid matter, and to take part in the formation of living protoplasm. What is the cause of this difference, we cannot at present say.

The Effects of Salts as Food. All food contains, besides the potential substances which we have just studied, certain saline matters organic and inorganic, having in themselves little or no latent energy, but yet either absolutely necessary or highly beneficial to the body. These must have important functions in directing the metabolism of the body: the striking distribution of them in the tissues, the preponderance of sodium and chlorides in blood-serum and of potassium and phosphates in the red corpuscles for instance, must have some meaning; but at present we are in the dark concerning it. The element phosphorus seems no less important from a biological point of view than carbon or nitrogen. It is as absolutely essential for the growth of a lowly being like *Penicillium* as for man himself. We find it probably playing an important part as the conspicuous constituent of lecithin, we find it peculiarly associated with the proteids, apparently in the form of phosphates; but we cannot explain its rôle. The element sulphur, again, is only second to phosphorus, and we find it as a constituent of nearly all proteids; but we cannot tell what exactly would happen to the economy if all the sulphur of the food were withdrawn. We know that the various saline matters are essential to health, that when they are not present in proper proportions, nutrition is affected, as is shewn by certain forms of scurvy; we are aware of the peculiar dependence of proteid qualities on the presence of salts; but beyond this we know very little.

SEC. 4. THE ENERGY OF THE BODY.

Broadly speaking, the animal body is a machine for converting potential into actual energy. The potential energy is supplied by food; this the metabolism of the body converts into the actual energy of heat and mechanical labour. We have in the present section to study what is known of the laws of this conversion, and of the distribution of the energy set free.

The Income of Energy.

Neglecting all subsidiary and unimportant sources of energy, we may say that the income of animal energy consists in the oxidation

of food into its waste products, viz. the oxidation of proteids into urea and carbonic acid, of fats into carbonic acid and water, and of carbohydrates into carbonic acid. Taking as our guide the principle laid down by the chemist, that the potential energy of any body, considered in relation to any chemical change in it, is the same when the final result is the same, whether that result be gained at one leap or by a series of steps—that, for instance, the energy set free by the oxidation of 1 grm. of fat into carbonic acid and water is the same, whatever the changes forwards or backwards which the fat undergoes before it finally reaches the stage of carbonic acid and water; and similarly, that the energy available for the body in 1 grm. of dry proteid is the energy given out by the complete combustion of that 1 grm., less the energy given out by the complete combustion of that quantity of urea to which the 1 grm. of proteid gives rise in the body—we may easily calculate the total energy of any diet. Frankland¹ has supplied the following data, given both in gramme-degree C units of heat, and metre-kilogramme units of force.

The direct oxidation of the following, dried at 100° C.	gives rise to	
	gram.-deg.	met.-kilo.
1 grm. Beef-fat	9069	3841
1 grm. Butter	7264	3077
1 grm. Arrowroot	3912	1657
1 grm. Beef-muscle purified with ether	5103	2161
1 grm. Urea	2206	934

Supposing that all the nitrogen of proteid food goes out as urea, 1 grm. of dry proteid, such as dried beef-muscle, would give rise to about $\frac{1}{3}$ grm. of urea; hence

	gram.-deg.	met.-kilo.
1 grm. Proteid	5103	2161
less		
$\frac{1}{3}$ grm. Urea	735	311
would give as		
Available energy of Proteid	4368	1850

In a normal diet, such as Ranke's, p. 358, would be found:

	gram.-deg.	met.-kilo.
100 grm. Proteid	436800	185000
100 grm. Fat	906900	384100
240 grm. Starch	938880	397680
Total Income	2281580	966780

or in round numbers, one million metre-kilogrammes.

¹ *Phil. Mag.* xxxii. p. 182.

The Expenditure.

There are only two ways in which energy is set free from the body—mechanical labour and heat. The body loses energy in producing muscular work, as in locomotion, in all kinds of labour, in the movements of the air in respiration and speech, and, though to a hardly recognisable extent, in the movements of the air or contiguous bodies by the pulsations of the vascular system. The body loses energy in the form of heat by conduction, radiation, by respiration and perspiration—in fact, by the warming of all the egesta. —All the internal work of the body, all the mechanical labour of the internal muscular mechanisms with their accompanying friction, all the molecular labour of the nervous and other tissues, is converted into heat before it leaves the body. The most intense mental action, unaccompanied by any muscular manifestations, the most energetic action of the heart or of the bowels, with the slight exceptions mentioned above, the busiest activity of the secreting or metabolic tissues, all these end simply in augmenting the expenditure of income in the form of heat.

A normal daily expenditure in the way of mechanical labour can be easily determined by observation. Whether the work take on the form of walking, or of driving a machine, or of any kind of muscular toil, a good day's work may be put down at about 150,000 metre-kilogrammes. The normal daily expenditure in the way of heat cannot be so readily determined. Direct calorimetric observations are attended with this difficulty, that the body while within the calorimeter is placed in abnormal conditions, which produce an abnormal metabolism. Hence results arrived at by this method are of little value unless they be accompanied by a comparison of the egesta and ingesta, so that the rate and nature of the metabolism going on may be known. Many attempts have been made to calculate the amount in an indirect manner. As trustworthy as any is the plan of simply subtracting the normal daily mechanical expenditure from the normal daily income. Thus, 150,000 m.-k. subtracted from one million m.-k. gives 850,000 m.-k. as the daily expenditure in the form of heat; *i. e.* between one-fifth and one-sixth of the total income is expended as mechanical labour, the remaining four-fifths or five-sixths leaving the body in the form of heat.

The Sources of Muscular Energy. Liebig, satisfied with having proved that the animal body was constructive as far as the formation of fat was concerned, held to the distinction between nitrogenous or plastic and non-nitrogenous or respiratory food. Put broadly, his view was that all the nitrogenous food went to build up the proteid tissues, the muscular flesh, and other forms of protoplasm, and that the nitrogenous egesta arose solely from the functional metabolism of these tissues, while the non-nitrogenous food was used with equal

exclusiveness for respiratory or calorific purposes, being either directly oxidised in the blood, or if present in excess, stored up as fatty tissue. According to him the two classes of income corresponded exactly to the two forms of expenditure. We have already urged several objections against this view. We have seen that in the blood itself very little oxidation takes place, that it is the active tissue, and not the passive blood-plasma, which is the seat of oxidation. We have further seen that proteid food may undoubtedly be in Liebig's sense respiratory, and incidentally give rise to the storing up of fat. One division of Liebig's view is thereby overthrown. We have now to inquire whether the other division holds good, whether muscle or other protoplasm is fed exclusively on the proteid material of food, and whether muscular energy comes exclusively from the metabolism of the proteid constituents of muscle. We have already seen (p. 58) that when the muscle itself is examined, we find no proof of nitrogenous waste, but, on the other hand, clear evidence of the production of non-nitrogenous bodies, such as carbonic and lactic acid. We have now to ask the question, Does muscular exercise increase the urea given off by the body as a whole? For this, according to Liebig's theory, it certainly ought to do. Conflicting evidence has been offered on this point; but by far the strongest and clearest is that which gives a negative answer.

In addition to the careful observations of Lawes and Gilbert, Edward Smith, Ranke, Voit and others, the long-continued and admirable inquiries of Parkes¹ are especially deserving of attention. This observer determined both the total nitrogen of the urine and of the fæces, so that no possible source of error could lie in this direction; and examined the effect of exercise, slight and severe, on both a non-nitrogenous and on a mixed nitrogenous diet. He found no marked increase in the urea, but often a diminution, during the exercise, though subsequently a slight increase took place. This after-increase possibly had nothing to do with the muscles in particular, but was the result of the exercise on the body at large.

The results of Flint², gained by observations on a celebrated pedestrian, rather illustrate the effects of protracted exercise on general proteid metabolism under a rich diet than contradict the more exact inquiries of Parkes.

More than this, the experience of Fick and Wislicenus³ lands us in an absurdity if we suppose the whole energy of muscular work to arise from proteid metabolism. They performed a certain amount of work (an ascent of the Faulhorn) on a non-nitrogenous diet, and estimated the amount of urea passed during the period. Assuming the urea to represent the oxidation of so much proteid matter, which oxidation represented in turn so much energy set free, they found that whereas the actual work done amounted to 129.096 and 148.656 metre-kilos, for each respectively, the total energy available from

¹ *Proc. Roy. Soc.* xv. (1867) p. 339; xvi. p. 44; xix. p. 349; xx. p. 402.

² *Journ. Anat. Phys.* Vol. xi. (1876); xii. (1877).

³ *Phil. Mag.* xxxi. (1866) p. 485.

carbonic acid when doing work, as against 708 grms. oxygen consumed, and 911 grms. carbonic acid produced, when remaining at rest, the quantity of urea secreted being in the first case 37 grms., in the second 37.2 grms.

These observers found that the production of carbonic acid was very distinctly diminished, and the consumption of oxygen increased, during the night as compared with the day. Thus the 1284.2 grms. of carbonic acid of the whole period of 24 hours was furnished by 884.6 grms. given out between 6 A.M. and 6 P.M., and 399.6 grms. between 6 P.M. and 6 A.M. Similarly, of the 954.5 grms. oxygen 294.8 grms. were taken in between 6 A.M. and 6 P.M., and 659.7 grms. between 6 P.M. and 6 A.M. These figures very strikingly indicate the independence of muscular contraction and *immediate* oxidation. There is no satisfactory proof that the time of day influences either the production of carbonic acid or the consumption of oxygen otherwise than by daylight being the natural time for work.

It is evident that the conclusions arrived at by the statistical method entirely corroborate those gained by an examination of muscle itself, viz. that during muscular contraction an explosive decomposition takes place, the non-nitrogenous products of which alone escape from the muscle and from the body, any nitrogenous products which result being retained within the muscle. We must therefore reject the second as well as the first division of Liebig's view, that the muscle is fed exclusively on proteid material, and that its energy arises from proteid metabolism.

We must, however, guard ourselves against rushing into the extreme opinion that a muscle is simply a machine for getting work out of the oxidation of non-nitrogenous food. The hypothesis advanced at p. 81 concerning the re-entrance of the nitrogenous products of metabolism into the composition of the nascent contractile substance, is undoubtedly a very rough and provisional idea. But if it means anything it means this, that the decomposition which gives rise to the carbonic and lactic acid, is a decomposition of the *whole contractile substance* and not of any non-nitrogenous portion of it, and that before a fresh decomposition can take place the whole complex explosive contractile material has to be made anew, and not simply a non-nitrogenous gap filled up. And this is probably true, not of muscular tissue only, but of all forms of active protoplasm however otherwise modified. It is, as we have seen, not in the case of muscle alone that the oxygen disappears into the molecular recesses of the tissue to reappear again in oxidized products whose oxidation does not take place at the moment of their production. We have more than once insisted that the oxidations of the body, in general at least, are oxidations by the tissues, and are oxidations in which the oxygen is first absorbed and made latent by the physiological actions of the protoplasm. In the at present unknown molecular actions, by which the raw material of the protoplasm is united with the absorbed oxygen in the manufacture of the explosive material, nitrogenous compounds evidently play a peculiar part. This is clearly shewn by the metabolic activity of proteid matters illustrated in the previous section. Indeed the whole secret of life may almost be said to be wrapped up in the occult properties

of certain nitrogen compounds; and Pflüger¹ has drawn some very suggestive comparisons between the so-called chemical properties of the cyanogen compounds, and the so-called vital properties of protoplasm. If we admit that the energy of muscular contraction (and with that the energy of all other vital manifestations) arises from an explosive decomposition of a complex substance, which we may call real protoplasm, and that this complex protoplasm is capable of reconstruction within limits which, as we urged at p. 343, may be very wide, we acquire a conception of physiological processes which, if not precise and definite, is at least simple and consistent, and moreover a first step towards a future molecular physiology.

The Sources and Distribution of Heat. Wherever metabolism of protoplasm is going on, heat is being generated. We have seen that heat is given out during muscular contraction; there is a similar development of heat during the activity of the secreting and of the other tissues; and the production of heat continues, though to a less extent, during the periods of rest as well as during those of action. All over the body heat is being set free; more abundantly in the more active tissues, and most of all in those tissues the metabolism of which leads to little or no external work. The metabolism of the tissues (including the blood) and of the food within the alimentary canal is the source of the heat of the body. But heat, while being thus continually produced, is as continually being lost, as we have seen, by the skin, the lungs, the urine and the fæces. The blood passing from one part of the body to the other, and carrying warmth from the tissues where heat is being actively generated, to the tissues or organs where heat is being lost by conduction or evaporation, tends to equalize the temperature of the various parts, and thus maintains a "constant bodily temperature."

When the production of heat is not great as compared with the means of loss, there is no great accumulation of heat within the body, the temperature of which consequently is but slightly raised above that of surrounding objects. Thus the temperature of the frog, for instance, is rarely more than $\cdot 04^{\circ}$ to $\cdot 05^{\circ}$ C. above that of the atmosphere, though in the breeding season the difference may amount to 1° . Such animals, and they comprise all classes except birds and mammals, are spoken of as cold-blooded. Exceptions among them are not uncommon. Some fish, such as the tunny, are warmer than the water in which they live, and in a species of Python (*P. bivittatus*) a difference of as much as 12° C. has been observed. Hüber found that in a beehive the temperature rose at times as much as to 40° C.

In the so-called warm-blooded animals, birds and mammals, the loss and production of heat are so balanced that the temperature of the body remains constant at, in round numbers, 35 or 40° C., whatever be the temperature of the air. The temperature of man is about $37\cdot 6^{\circ}$ C.; in some birds it is as high as 44° C. (*Hirundo*), and in the wolf it is said to be as low as $35\cdot 24^{\circ}$ C. This temperature is with slight

¹ Pflüger's *Archiv*, x. (1875) 251.

variations maintained throughout life. After death the generation of heat rapidly diminishes, and the body speedily becomes cold; but for some short time immediately following upon systemic death, a rise of temperature may be observed, due to the fact that, while the metabolism of the tissues is still going on, the loss of heat is somewhat checked by the cessation of the circulation. The onset of pronounced rigor mortis causes a marked accession of heat, and when occurring after certain diseases, may give rise to a very considerable elevation of temperature. This mean bodily temperature of warm-blooded animals is, during health, maintained, with slight variations of which we shall presently speak, within so narrow a margin as 2° C., a fall or rise of more than 1° C. beyond these limits being indicative of some failure in the organism, or of some unusual influence being at work. It is evident, therefore, that the mechanisms which co-ordinate the loss with the production of heat must be exceedingly sensitive. It is obvious, moreover, that these mechanisms may act when the bodily temperature is tending to rise, by either checking the production or by augmenting the loss of heat; and when the bodily temperature is tending to fall, by either increasing the production or by diminishing the loss of heat. As the regulation of temperature by variations in the loss of heat is far better known than regulation by variations in production, it will be best to consider this first.

Regulation by variations in loss. Taking the body as a whole, under normal conditions, the chief sources of the production of heat are the muscles and the abdominal viscera, more especially the liver; and of these the liver deserves attention, inasmuch as it is always at work, whereas the heat produced by the muscles is at least largely dependent on their contracting, and they may remain at rest for considerable periods. We find indeed that the blood in the hepatic veins is the warmest in the body. Heidenhain¹ observed in the dog a temperature of 40.73° C. in the hepatic vein, while that of the vena cava inferior was 38.35° to 39.58° , and that of the right heart 37.7° . Bernard previously had found the blood of the hepatic vein warmer than that of either the portal vein or the aorta, shewing that the increased temperature is not due simply to the liver being far removed from the surface of the body. The brain too may be regarded as a source of heat, since its temperature is higher than that of the arterial blood with which it is supplied; though from the smaller quantity of blood passing through its vessels it cannot in this respect compare with either the liver or the muscles as a source of heat to the body.

Heat is lost to the body by the warming of the fæces and of the urine, by the warming of the expired air, by the evaporation of the water of respiration, by conduction and radiation through the skin, and by the evaporation of the water of perspiration. Helmholtz

¹ Pflüger's *Archiv*, iii. (1870) p. 504.

has calculated that the relative amounts of the loss by these several channels are as follows :

In warming the fæces and urine 2·6 per cent.

In warming the expired air 5·2 per cent.

In evaporating the water of respiration 14·7 per cent.

In conduction and radiation and evaporation by the skin 77·5 per cent.

The two chief means of loss then, which are at all susceptible of any great amount of variation, and which can be used to regulate the temperature of the body, are the skin and the lungs.

The more air passes in and out of the lungs in a given time, the greater will be the loss in warming the expired air, and in evaporating the water of respiration. And in such animals as the dog, which do not perspire freely by the skin, respiration is a most important means of regulating the temperature¹.

While Bernard², G. Liebig³, Heidenhain and older observers, found the blood of the right heart warmer (from ·1 to ·3°) than that of the left, Colin⁴ and Jacobson and Bernhardt⁵ state that the left heart is warmer or at least as warm as the right. From the latter observations it might be inferred that the loss of heat by respiration is neutralized by chemical changes going on in the lungs. Heidenhain and Kürner⁶, however, make the important observation that the higher temperature of the right ventricle is independent of the respiration, and they attribute the difference between the two ventricles solely to the fact that the right ventricle lies nearer to the abdominal viscera, the high temperature of which has already been mentioned. And they argue that the loss of heat from the body to the air has been already achieved before the inspired air reaches the pulmonary alveoli, the evaporation of water taking place chiefly in the nasal and bronchial passages.

The great regulator however is undoubtedly the skin. The more blood passes through the skin the greater will be the loss of heat by conduction, radiation, and evaporation. Hence, any action of the vaso-motor mechanism which, by causing dilation of the cutaneous vascular areas, leads to a larger flow of blood through the skin, will tend to cool the body; and conversely, any vaso-motor action which by constricting the cutaneous vascular areas, or by dilating the splanchnic vascular areas, causes a smaller flow through the skin, and a larger flow of blood through the abdominal viscera, will tend to heat the body. If, as seems probable (see p. 315), there are special nerves of perspiration, these will act directly as regulators of temperature, increasing the loss of heat when they promote, and lessening the loss when they cease to promote, the secretion of the skin. The working of this heat-regulating mechanism is well seen in the case

¹ See Riegel, Pfüger's *Archiv*, v. (1872) 651.

² *Leç. de Phys. Exp.* 1855.

³ *Ueber die Temperaturunterschiede des venösen und arteriellen Blutes.* Giessen, 1853.

⁴ *Compt. Rend.* Lxii. (1865) p. 680.

⁵ *Cbt. f. Med. Wiss.* 1868, p. 643.

⁶ Pfüger's *Archiv*, iv. (1871) 558.

of exercise. Since every muscular contraction gives rise to heat, exercise must increase for the time being the production of heat; yet the bodily temperature rarely rises so much as a degree C., if at all. By the exercise the respiration is quickened, and the loss of heat by the lungs increased. The circulation of blood is also quickened, and the cutaneous vascular areas becoming dilated, a larger amount of blood passes through the skin. Added to this, the skin perspires freely. Thus a large amount of heat is lost to the body, sufficient to neutralise the increase caused by the muscular contraction, the increase which the more rapid flow of blood through the abdominal organs might tend to bring about being more than sufficiently counteracted by their smaller supply for the time. The sense of warmth which is felt during exercise in consequence of the flushing of the skin, is in itself a token that a regulative cooling is being carried on. In a similar way the application of external cold or heat, either partially or completely, defeats its own ends. Under the influence of external cold the cutaneous vessels are constricted, and the splanchnic vascular areas dilated, so that the blood is withdrawn from the colder and cooling regions to the hotter and heat-producing organs. This vascular change may produce such an effect, that the result of stripping naked in a cold atmosphere may be an actual increase in the mean temperature of the blood, as indicated by a thermometer placed in the mouth. Under the influence of external warmth, on the other hand, the cutaneous vessels are dilated, a rapid discharge of heat, especially by evaporation, takes place; and if the circumstances be such that the body can perspire freely, and the perspiration be readily evaporated, the temperature of the body may remain very near to the normal, even in an excessively hot atmosphere. Thus, more than a century ago, Drs Fordyce and Blagden¹ were able to remain with impunity in a chamber heated even to 127° (260° Fahr.), and with ease in one so hot, that it became painful for them to touch the metal buttons of their clothing. It is unnecessary to give any more examples of this regulation of temperature by variations in the loss of heat; they all readily explain themselves.

Regulation by variations in production. Much less satisfactory is our information concerning the regulation of the *production* of heat. We can easily conceive that afferent impulses passing along certain nerves might increase the metabolism of the muscles, the liver, and other organs, and so lead to a greater development of heat, and conversely, that the failure of wonted impulses or the passage of inhibitory impulses might diminish metabolism and lower the production of heat; and that these impulses might be connected in a reflex manner with the skin or other regions. We can imagine, in fact, the existence of a metabolic nervous mechanism quite comparable to the vaso-motor mechanism and to the various secreting

¹ *Phil. Trans.* 1775, pp. 111, 484.

nervous mechanisms. And indeed we have some positive evidence of the existence of such a mechanism; but at present our knowledge concerning the matter is far from being complete.

The high temperature of certain diseases (pyrexia, &c.) and the low temperature of others (diabetes) have not yet been thoroughly investigated; but there is already sufficient evidence to shew that, in some cases at least, the phenomena are the result of excess or deficiency of production, and not of mere deficiency or excess of escape.

The effects of external cold and warmth have been appealed to as indicative of variations in the production of heat. Thus upon stripping in a cold atmosphere or upon first entering into a cold bath, the temperature of the mouth or rectum rises instead of falling. Again on entering into a bath at blood-heat, the temperature of the mouth or rectum does not, as might be expected from the diminution of the loss of heat, rise, but may even at first fall slightly. These results may, it is true, be approximately explained on the ground that in the first case the constriction of the cutaneous vessels shuts off a large quantity of blood from the cooling surfaces, and thus prevents a loss of heat, while in the second case a larger quantity of blood is by the dilation of the cutaneous vessels withdrawn from the warmer to what are at first the cooler regions of the body. We have, however, experimental evidence that in mammals external cold increases while external warmth diminishes, the total metabolism of the body; from which it may fairly be inferred that these agents affect not only the distribution but the actual production of bodily heat. Thus Sanders-Ezn¹ found that in rabbits the production of carbonic acid was increased by sudden exposure of the bodily surface to cold and diminished by sudden exposure to warmth. Röhrig and Zuntz² found in rabbits an increase in both the carbonic acid produced and in the oxygen consumed to result from cold baths, and also though to a less extent from saline baths. Colasanti³ has further shewn that in guinea-pigs cold increases, in a very remarkable and regular manner, both the production of carbonic acid and the consumption of oxygen. And since the ratio of the oxygen consumed to the oxygen contained in the carbonic acid expired remained constant during the experiments, we are justified in concluding that the increase in both was due to an increase of metabolism. A strong contrast to the behaviour of the warm-blooded guinea-pig, in which a fall of 30° C. in the surrounding medium actually doubled the amount of the metabolism, is afforded by the cold-blooded frog, in which, according to Pflüger and Schulz⁴, repeating the earlier experiments of Marchand and Moleschott, cold depresses and heat exalts the metabolic activity of the tissues. Evidently the production of heat is, in the warm-blooded animal, governed by a regulative mechanism which is either absent or very feebly developed in the cold-blooded animal.

With regard to the exact nature of this mechanism, the following facts deserve attention. Zuntz and Röhrig⁵ found that in urari poisoning there was a marked diminution of the bodily metabolism as indicated by

¹ Ludwig's *Arbeiten*, 1867.

² Pflüger's *Archiv*, iv. (1871) p. 57.

³ Pflüger's *Archiv*, xiv. (1877) p. 92.
See also the subsequent controversy carried on in that and the following volume.

⁴ Pflüger's *Archiv*, xiv. (1877) 73.

⁵ *Op. cit.* and Zuntz, Pflüger's *Archiv*, xii. (1876) p. 522.

the quantities of oxygen consumed and carbonic acid produced; these indeed might fall to half the normal. At the same time the bodily temperature fell considerably; and that this fall was the effect and not the cause of the diminution of the metabolism was shewn by the fact that the metabolism continued to diminish, when loss of heat from the body was prevented by wrappings of cotton wool. While under urari too, the metabolic activity was far less influenced by cold and other baths. These experiments suggest that when cold is applied to the skin, afferent impulses are generated which, reaching some central nervous mechanism, give rise to efferent impulses, which in turn passing to the muscles, increase the metabolic activity of these organs, and thus give rise to an increased production of heat. When the muscular nerves are paralysed by urari, the efferent impulses can no longer reach the muscles, and hence no increase of metabolism takes place in them. Pointing in the same direction, are the experiments of Samuel¹, who found that while rabbits in a normal condition will bear exposure to even severe cold without any great change in their bodily temperature, this sinks rapidly, and death ensues, when the chief muscular parts of the body are eliminated from the total action of the organism by ligation of all four arteries of the limbs or by section of their main nerve-trunks; the wounds necessary for the operation producing of themselves only a slight effect.

Although in the above experiments the diminution of metabolism and of the production of heat was coincident with the absence of muscular contractions, it is not absolutely necessary to suppose that the occurrence of contractions is essential to an increase in the production of heat. There is no *à priori* reason positively contradicting the hypothesis that the metabolism of even muscular tissue might be influenced by nervous or by other agency in such a way that a large decomposition of the muscular substance, productive of much heat, might take place without any contraction being necessarily caused. If we were to permit ourselves to suppose that the contractile material whose metabolism when resulting in a contraction gives rise to so much heat, could undergo the same amount of metabolism, in so far a different fashion, that all the energy thereby set free took on the form of heat, variations in the temperature of the body, at present difficult to understand, would become readily intelligible.

We have further indications of the existence of what may be called 'thermogenic' nerves and thermogenic nervous mechanisms in the variations of temperature attendant on section of, or injury to, or disease of, the spinal cord and other parts of the nervous system. Brodie² was one of the first to call attention to a rise of temperature after injury to the spinal cord; in a previous memoir³ he had contended, on insufficient grounds it is true, for a direct generation of heat by means of the nervous system. Since that time many cases have been observed on the one hand of a lowering and on the other hand of a rise of temperature as the result of injury to, or disease of, the spinal cord, or other parts of the central nervous system. The experimental evidence is not at present satisfactory. Tscheschichin⁴ observed in rabbits a fall of temperature after section of the spinal cord, but a marked rise of temperature after a section carried through the juncture of

¹ *Ueber die Entstehung der Eigenwärme &c.* Leipzig, 1876.

² *Med. Chir. Trans.* Vol. xx. (1837) p. 119.

³ *Phil. Trans.* 1811, 1812.

⁴ Du Bois-Reymond's *Archiv*, 1866, p. 151.

the medulla oblongata and pons Varolii. Naunyn and Quincke¹, on the contrary, found that, in dogs, section of the spinal cord was followed at first by a fall, but subsequently by a rise of temperature, the latter being the more marked the higher up the division of the cord, and reaching to as much as 3° or 4°. They explained the initial fall as due to an increased escape of heat, due to the vaso-motor paralysis, which the section caused, allowing a large portion of the blood to pass through the cutaneous vessels; and they remarked that the fall was less the more rapidly after the operation the animal was surrounded by cotton wool or like bad conductors of heat. The subsequent rise of temperature they attributed to an actual increased production which in time overcame the increased escape due to vaso-motor paralysis. They thought that they had satisfied themselves that the rise was not due to fever occasioned by the mere wound, as Schroff² has since concluded. Parinaud³ finds that in rabbits section of the spinal cord invariably produces a continued fall of temperature, especially of the deeper parts of the body, more marked in the paralysed than in the non-paralysed parts. Tscheschichin attributed the rise which he observed after the section of the medulla to the removal of some inhibitory action exerted by the higher parts of the brain on thermogenic centres lower down. Further researches are needed before any satisfactory conclusion can be arrived at. Many of the phenomena observed may undoubtedly be explained by vaso-motor action, by the derivation of a large quantity of blood from a part of the body where production is greater than loss to a part where escape by conduction or evaporation overcomes production, or *vice versa*. But even the vaso-motor problems are themselves involved, and the elaborate researches of Heidenhain⁴ shew how great a caution is necessary in drawing conclusions from experiments dealing with so complicated a machinery as the vascular system. This so careful observer found that the stimulation of the sensory nerve of an animal (sciatic of dog) under urari produced, coincident with the increase of arterial pressure, a diminution (as much as 1° C.) of the temperature in the interior of the body, but that this fall did not occur when the animal was in a febrile condition. This at first sight looked like the indication of a thermotoxic mechanism, rendered inactive by the condition of fever. When however the animal under urari, but otherwise normal, was placed in a cold bath the fall of temperature resulting from stimulation of the sciatic was greater than under the ordinary circumstances, and when it was placed in a hot bath the stimulation of the sciatic caused a rise instead of a fall of the internal temperature. Moreover, when a fevered dog was cooled by being placed in a cold bath, a fall of temperature similar to the normal was seen to follow stimulation of the sciatic. Evidently the rise or fall in the several cases was to be referred to the condition of the cutaneous vessels, warm in the one case and cold in the other, rather than to any direct thermogenic activity of the nervous system. But it is difficult to account, by any working of a mere vaso-motor mechanism, for the marked rise of temperature often seen in even slight cases of spinal disease, especially when the rise is so great as, even allowing

¹ Du Bois-Reymond's *Archiv*, 1869, p. 174, 521.

² *Wien. Sitzungsberichte*, LXXIII. (1876).

³ *Archives de Physiologie* (II) IV. (1877), pp. 63, 810.

⁴ *Pflüger's Archiv*, 1870, III. 504; *Ibid.* V. (1872) 77.

for all possible errors, it must have been in some of the cases recorded¹. It seems hardly possible in such instances as these not to entertain the idea of some direct action of the nervous system on heat-producing metabolism.

Bernard² feels justified in speaking most distinctly of 'thermogenic' or 'calorific' and of 'frigorific' nerves, in complete analogy with vaso-dilator and vaso-constrictor nerves. He states³ that after division of one cervical sympathetic the temperature of the ear of the side operated on remains considerably higher than that of the other side, at a time when the increased vascularity has nearly disappeared, thus indicating that the former is not wholly dependent on the latter; and Knock⁴ confirms this. Bernard⁵ also observed, after division of the cervical sympathetic on one side, that a stimulation of the central end of the divided auricular nerve sufficiently intense to give rise to pain, occasioned on the side in which the sympathetic was intact, a fall (of as much as 2° C.) of temperature in the ear, *unaccompanied by any pallor*, while on the side on which the sympathetic had been divided, a rise of temperature was at the same time observed. That is to say, the sensation of pain gave rise, by reflex action through the intact cervical sympathetic, to a refrigeration of the ear, without any vascular change in the ear and in spite of an increased temperature of other parts of the body. In the submaxillary gland he found that while stimulation of the chorda tympani produced a rise, stimulation of the sympathetic produced a fall of temperature, which manifested themselves, though to a less degree than in normal circumstances, even when all the vessels were cut or when the veins were ligatured. Ludwig and Spiess⁶ had previously shewn that during stimulation of the chorda the temperature of the saliva excreted might be 1 or 1.5 degree higher than that of the blood in the carotid artery. If it could be shewn that under stimulation of the sympathetic a corresponding but negative difference manifested itself, Bernard's view that the sympathetic is par excellence a frigorific nerve, while the cerebrospinal nerves contain all the calorific fibres, would receive a striking confirmation. Heidenhain's⁷ observations, however, as far as they go, point to a slight rise rather than a fall of temperature as the result of sympathetic stimulation.

By regulative mechanisms of this kind the temperature of the warm-blooded animal is maintained within very narrow limits. In ordinary health the temperature of man varies between 36° and 38°, the narrower limits being 36.25° and 37.5°, when the thermometer is placed in the axilla. In the mouth the reading of the thermometer is somewhat (25° to 1.5°) higher; in the rectum it is still higher (about .9° C.) than in the mouth. The temperature of infants and children is slightly higher and much more susceptible of variation than that of adults, and after 40 years of age the average maximum temperature (of health) is somewhat lower than before that epoch.

¹ *Lancet*, March 6, 1875.

² *Chaleur Animale* (1876), *passim*.

³ *Op. cit.* p. 283.

⁴ Quoted by Bernard *loc. cit.* The observations of Goltz, see p. 166, on the foot of the dog would seem to shew that this at least does not hold good for the sciatic nerve.

⁵ *Op. cit.* p. 295.

⁶ *Wien. Sitzungsberichte*, xxv. 1857.

⁷ *Breslau. Studien*, iv. 1868.

A diurnal variation, independent of food or other circumstances, has been observed¹, the maximum ranging from 9 A.M. to 6 P.M. and the minimum from 11 P.M. to 3 A.M. Meals cause sometimes a slight elevation, sometimes a slight depression, the direction of the influence depending on the nature of the food: alcohol seems always to produce a fall. Exercise and variations of external temperature, within ordinary limits, cause very slight change, on account of the compensating influences which have been discussed above. The rise from even active exercise does not amount to 1° C.; when labour is carried to exhaustion a depression of temperature may be observed. In travelling from very cold to very hot regions a variation of less than a degree occurs, and the temperature of tropical inhabitants is practically the same as those dwelling in arctic regions.

When external cold or warmth passes certain limits, or when during the application of these agents the regulative mechanisms are interfered with, the temperature of the body may be lowered or raised until death ensues. When the cold or warmth applied is not very great, as in cold and warm baths, it has been noticed that the temperature is more easily raised by warmth than depressed by cold. Death ensues from extreme cold by a depression of the activities of all the tissues, more especially of the nervous; asphyxia is produced in animals when the fall of temperature is rapid. Puppies can be recovered after the temperature in the rectum has fallen to about 4° or 5° C., and hibernating mammals may be cooled with impunity down to nearly freezing point. Horvath² observed when external warmth is brought to bear on a mammal in such a way as to cause a rise of temperature in the body, death ensues when an elevation of about 6° or 7° C. above the normal is reached; and Bernard³ places the lethal bodily temperature of a mammal at about 46°. The exact cause of the death has not been as yet sufficiently explained. It cannot be due, as Bernard suggests, to the muscles entering into rigor caloridis, for the animals frequently succumb before this takes place. A high temperature makes the heart irregular, and finally stops its beat, but probably other tissues are also injuriously affected, so that death cannot be attributed to the stoppage of the heart alone.

One of the most marked phenomena of starvation is the fall of temperature, which becomes very rapid during the last days of life. Indeed the low temperature of the body is a powerful factor in bringing about death, for life may be much prolonged by wrapping a starving animal in some bad conductor so as to economise the bodily heat⁴.

¹ Ringer, *Proc. Roy. Soc.* xvii. p. 287.

² *Cbl. f. Med. Wiss.* 1871, p. 513.

³ *Leç. sur la Chaleur Animale*, 1876.

⁴ Chossat, *Rech. Exp. sur l'Inanition*, Paris, 1843.

SEC. 5. THE INFLUENCE OF THE NERVOUS SYSTEM ON NUTRITION. X

In the preceding sections we had more than once to refer to the possibility of the nervous system having the power of directly affecting the metabolic actions of the body, apart from any irritable, contractile, or secretory manifestations. Thus the phenomena of diabetes cannot, at present at all events, be satisfactorily explained as a purely vaso-motor effect, and the production of heat seems to be under some special guidance of the nervous system. In treating of the salivary glands we met with the striking fact that when all the nerves of the gland have been divided, and a 'paralytic' secretion set up, the tissue of the gland may ultimately degenerate. This result differs from the wasting of a muscle which follows upon severance of its motor nerve, since this may be, partly at all events, explained by the fact that the muscle is no longer functional; and indeed, if the muscle is rendered functional, if it is directly stimulated for instance from time to time with a galvanic current, the atrophy may be postponed or even altogether prevented. But the salivary gland in the case in question is functional, it does go on secreting; nevertheless in the absence of its usual nervous guidance its nutrition becomes profoundly affected. We are not justified in saying that in this case the nutrition of the salivary cell is directly dependent on the nervous system, because all biological studies teach us that the growth, repair, and reproduction of protoplasm may go on quite independently of any nervous system, and the nutrition of the nervous system itself cannot be dependent on its action on itself; but we may go so far as to infer that the nutrition of the salivary cell is in the complex animal body so arranged to meet the constantly recurring influences brought to bear on it by the nervous system, that, when those influences are permanently withdrawn, it is thrown out of equilibrium; its molecular processes, so to speak, run loose, since the bit has been removed from their mouths. And we might expect that similar instances would be met with where nutrition became abnormal after the removal of wonted nervous influences. Such instances indeed are not uncommon; the most familiar being perhaps the rapid occurrence of bed-sores, in consequence of injuries to or of disease of the spinal cord or brain. And there are many pathological phenomena, inflammation itself to begin with, which seem inexplicable, except when regarded as the results of nervous action. In all these cases, however, there are many attendant circumstances to be considered before we can feel justified in speaking of any direct influence of the nervous system on nutrition, of any specific action of what have been called 'trophic' nerves. Perhaps the instance which has been best worked out is the connection of the nutrition of the eye and face with the fifth or trigeminal nerve. When in a rabbit the trigeminus is divided in the skull there is loss of sensation in those parts of the face of which it is the sensory nerve. Very soon, within twenty-

four hours, the cornea becomes cloudy; and this is the precursor of an inflammation which may involve the whole eye and end in its total disorganisation. At the same time the nasal chambers of the same side are inflamed, and very frequently ulcers make their appearance on the lips and gums. Seeing how delicate a structure the eye is, and how carefully it is protected by the mechanisms of the eyelids and tears, it seems reasonable to suppose that the inflammation in question might simply be the result of the irritation caused by dust and contact with foreign bodies, to which the eye, no longer guided and protected by sensations, these being destroyed by the section of the nerve, became subject. In the same way the ulcers on the lips and gums might be explained as injuries inflicted by the teeth on those structures in their insensitive condition. And Snellen found that the inflammation of the eye might be greatly lessened or altogether prevented if the organ were carefully covered up and in all possible ways protected from the irritating influences of foreign bodies. Other observers however have failed to prevent the inflammation in spite of every care. This negative result is in itself no strong argument, but there are other facts which seem to shew that the tissues in question are, after section of the nerves, in a peculiar condition.

Sinitzen found that after removal of the superior cervical sympathetic ganglion, the inflammatory effects of section of the trigeminus were very much lessened. Sinitzen's explanation, that the tissues of the face become less irritable after removal of the ganglion, seems, however, hardly satisfactory. According to Merkel¹ the inflammatory phenomena depend on a particular portion of the nerve being divided. He states that if a certain tract along the inner border of the nerve be alone cut, there is no loss of sensation either in the cornea or other parts of the face, but yet inflammation comes on as usual; if, on the other hand, the whole nerve be carefully divided with the exception of this tract, no inflammation ensues though sensation is lost. Merkel traces the fibres forming the inner border to a deep origin, different from that of the rest of the nerve. If these results be corroborated, the trigeminus must be held to contain 'trophic' fibres.

The significance of these inflammation phenomena must therefore be left at present undecided. Few similar cases have been observed, the most striking being the occurrence of pneumonia after section of the vagi; yet there seems to be no reason why the fifth nerve should be conspicuous in possessing trophic fibres. When the sciatic nerve of the frog is divided, no nutritive alterations beyond those explicable as the result of loss of function are observed; and indeed the majority of the effects on growth and nutrition resulting from the section of nerves, or from paralysis, can be referred to the absence of the usual functional activity, accompanied in some cases with an altered vascular supply. Nevertheless the numerous pheno-

¹ *Untersuch. Anat. Inst. Rostock*, p. 1.

mena of disease, joined to the facts mentioned above, turn the balance of evidence in favour of the view that some more or less direct influence of the nervous system on metabolic actions, and so on nutrition, will be established by future inquiries.

The influence which light acting on the retina appears to exercise on the metabolism of the body may be quoted as an illustration of the statement just made¹.

SEC. 6. DIETETICS.

We may sum up the main results of the previous sections somewhat in the following way. Although the body consists, like the food, of proteids, fats and carbohydrates, yet the conversion of the one into the other is not direct. Assimilation does not proceed in such a way that the proteids of the food all become the proteids of the body, the fats of the food the fats of the body, and the starch and sugar of the food the glycogen, dextrin, and sugar of the body. We cannot even say that the non-nitrogenous food supplies alone the non-nitrogenous parts of the body, while the nitrogenous food remains as the sole source of the nitrogenous tissues. We have seen that under all circumstances a certain quantity of proteid food is immediately metabolized, probably while still within the alimentary canal, and that when an excess of proteid food is taken a *luxus* consumption leads to the accumulation of bodily fat. On the other hand, we find that a large proportion of the carbonic acid of the egesta comes from the metabolism of nitrogenous tissues, such as muscle; and we have had proof that the energy set free by muscular contraction may be far greater than could be supplied by the proteid food taken, and that therefore the non-nitrogenous factors of the metabolism which set free the energy must have *ultimately* come from non-nitrogenous food. We have abundant evidence that the various food-stuffs become more or less metabolized, and their elements more or less rearranged and mixed before they reappear as constituents of the bodily tissues.

We have seen that the oxidations of the body are, as in the case of muscle, of a peculiar character, and carried on by the tissues themselves. While at present we should be hardly justified in denying that any oxidations at all take place in the blood-plasma, such as do occur must be slight in amount as compared with those going on in the tissues. We might also say that one body only, viz. lactic acid, presents itself as a substance likely to be directly oxidised in the blood itself; and even with regard to this the evidence is as much against as for any such direct oxidation taking place. The great mass of the oxidation of the body is of an indirect kind, determined by the activity of the several tissues. The blood serves as an

¹ Cf. Pflüger and Von Platen, Pflüger's *Archiv*, xi. 263, 272. Fubini, Moleschott's *Untersuch.* xi. 488.

oxygen carrier for the tissues; and it is not itself the large combustion agent it was once thought to be. The tendency of all recent inquiries is to shew that the body cannot be compared, either as a whole, or in its parts, to a furnace for the direct combustion of combustible food. On the contrary, we are driven nearer and nearer to the conclusion that all food which has become absorbed into the blood must become tissue before it becomes waste product, and only becomes waste product through a metabolism of the tissue. When we say "become tissue" we must leave it at present wholly undecided how far the constant metabolism which this view demands affects the so-called structural elements of the more highly organized tissues; it is quite open however for us to imagine that the ground-substance of muscle, for instance, might undergo large and rapid metabolism, while the change of the sarcous elements or muscle-rods might be much slighter and slower.

The characteristic feature of proteid food is that it increases the oxidative, metabolic activity of the tissues, leading to a rapid consumption, not only of itself, but of non-nitrogenous food as well. Where therefore a rapid renewal of the tissues is sought for, an excess of proteid food may be desirable. But it must be borne in mind that by the very nature of its rapid metabolism, proteid food must tend to load the body with the so-called extractives, *i.e.* with nitrogenous crystalline bodies. How far these are of use to the body, and what part they play, is at present unknown to us. That they are of some use is suggested by the beneficial effects of the *extractum carnis* when taken as food in conjunction with non-nitrogenous material, though it is possible that the dietetic value of this preparation may be due to the small amount of non-crystalline extractives which it contains. That when in excess they may be highly injurious is indicated by the little we know of the connection between the symptoms of gout and the presence of uric acid. A large meal of proteid material must tax the system to the utmost in getting rid of or stowing away the nitrogenous crystalline bodies arising through the luxur consumption either in the alimentary canal or in the liver.

One value of fats and carbohydrates lies in their being sources of energy, more than three-fourths of the normal income of potential energy coming from them (p. 367); and, as we have seen, they are *ultimate* sources of muscular energy as well as of heat. But their great characteristic is that they do not, like proteid food, excite the metabolic activity of the body. Hence, unlike proteid food, they can be retained and stored up in the body with comparative ease. The digested elements of fatty or carbohydrate food which go to form the protoplasm of adipose tissue, become part and parcel of a substance which can perform its metabolism without any explosive expenditure of energy, and which therefore, instead of giving rise to bodies demanding immediate excretion from the system, can deposit its metabolic products as apparently little, but as we have seen in reality

greatly, changed fat. In this way the non-nitrogenous food of to-day is rendered available for future and even far distant wants.

In comparing fats with carbohydrates, we can only point to the much greater potential energy of the former than of the latter, weight for weight (see p. 367), and to the fact that the latter, by containing so to speak water ready formed, and by thus affording material for evaporation, hold within themselves a means of getting rid of some of the energy which is set free by their metabolism, when that energy takes on the form of heat.

A diet may be chosen either for the simple maintenance of health, or for the sake of muscular energy, or for fattening purposes. For the first purpose there is, we may suppose, a normal diet; and in the case of man, instinct has probably not erred far in choosing some such proportions as those given on p. 358. If, as we have urged, all food becomes tissue before it leaves the body as waste product, the dominant principle of all nutrition, and the ultimate tribunal of all questions of diet, must be the individual character of the tissue, the idiosyncrasy of the body. The same mysterious qualities which cause the same blood-plasma to become here a muscle, and there a secreting cell, convert the same food into the body of a man or of a sheep. All the simpler and more general laws of metabolism are made subservient to more intricate and special laws of protoplasmic construction. We can only speak of a normal diet in the same way that we speak of the average intelligence of man.

In seeking to supply such a normal diet out of ordinary articles of food, we must bear in mind that the nutritive value of any substance, estimated in terms of the potential energy of the proteids, fats or carbohydrates it contains, must of course be corrected by its digestibility. One gramme of cheese has, as far as potential energy is concerned, an exceedingly high value; but the indigestibility of cheese brings its nutritive value to a very low level. Here too the factor of idiosyncrasy makes itself exceedingly felt.

In feeding for fattening purposes the comparatively cheap carbohydrates are of course chiefly depended on. If the view mentioned on p. 364 be correct, that the fat really stored up all comes from proteid metabolism, an equivalent of this food-stuff must always be given. If, as seems probable, this view is a too hurried generalisation, there still remains the possibility that for economical fattening, with the least waste, a certain proportion between the nitrogenous and non-nitrogenous foods must always be maintained.

From what has been previously said it is evident that proteid food is not the only food-stuff to be regarded in selecting a diet for muscular labour. We should however equally err in the opposite direction if we selected exclusively non-nitrogenous food on which to do work, since, as we have seen, there is no evidence that the fats or carbohydrates are the *direct*, though they may be in part the *ultimate* source, of muscular energy. Considering how complex a thing strength is, how much it depends on the vigour of parts of the body other than the

muscles, a normal diet, calculated to develop equally all parts of the body, is probably the best diet for active labour. It is possible however that an excess of proteid food, by reason of the renewal of tissue caused by its metabolic activity, may be, in such cases, of service.

Lastly, the several saline matters, including the extractives of animal and vegetable food, are no less essential elements of a diet than proteids, fats, or carbohydrates. Of use, not for the energy they themselves possess, but by reason of their regulating the energy of the food-stuffs more strictly so called, they are necessary to life: the body in their absence fails to carry out its usual metabolism, and disease if not death follows.

The dietetic superiority of fresh meat and vegetables depends in part on their still retaining these various saline and extractive matters. A diet from which phosphorus (or even possibly phosphates), or chlorides, or potash, or soda salts are absent, is, as soon as the store of the substance in the body is exhausted, useless for nutritive purposes. Calcium and magnesium may, to a certain extent, be replaced by bases closely allied to them; but the metabolic rôle of phosphorus or of sulphur cannot be taken up by any analogous body; and, as is illustrated by their distribution in the body, the physiological functions of potash and soda are widely different if not antagonistic, closely allied as are these two alkalis when regarded from a chemical point of view. Like medicines and poisons—and indeed they are in a manner natural medicines—the action of these bodies depends in part on their dose. Indispensable as are potash salts to the economy, a large dose of them is injurious; and a dog fed on nothing but Liebig's extract dies sooner than a dog not fed at all, on account of the potash salts of the extract exerting their deleterious influence in the absence of the food whose metabolism their function is to direct.

The physiology of nutrition may be said to have been founded by Liebig, when he proved the formation of fat in the animal body, and published his views on the nature and use of food. The labours of Regnault and Reiset¹ added much to our knowledge of the Statistics of Respiration. The first elaborate inquiry into the Statistics of Metabolism in general was that of Bidder and Schmidt²; this was followed by the investigations of the Munich school, viz. Bischoff, Bischoff and Voit³, Voit, and Pettenkofer and Voit⁴. Although we have had occasion to combat some of the views of this school, it must be admitted that their extended and laborious researches have been the means of an immense advance in our knowledge. Their method has been largely adopted, with excellent results, by the various agricultural stations in Germany; and in this country the inquiries of Lawes and Gilbert⁵ have given us information of peculiarly valuable character, inasmuch as it is chiefly based on direct analysis and observation, and therefore free from the possibilities of error attaching to mere calculations. If, however, one discovery can be pointed to as influencing our views of the nature and laws of animal metabolism more than any other, it is that by Bernard⁶, of the formation of glycogen by the liver.

¹ *Ann. Ch. Phys.* 1849 (3) xxvi. 32.

² *Op. cit.*

³ *Op. cit.*

⁴ *Op. cit.* and many subsequent memoirs in the *Zt. für Biol.*

⁵ *Op. cit.*

⁶ *Op. cit.*

BOOK III.

THE CENTRAL NERVOUS SYSTEM AND ITS INSTRUMENTS.

586
2036

CHAPTER I.

SENSORY NERVES.

IN studying the phenomena of motor nerves we are greatly assisted by two facts: First, that the muscular contraction by which we judge of what is going on in the muscle, is a comparatively simple thing, one contraction differing from another only by such features as amount, rapidity, and frequency of repetition, and all such differences being capable of exact measurement. Secondly, that when we apply a stimulus directly to the nerve itself, the effects differ in degree only from those which result when the nerve is set in action by natural stimuli, such as the will. When we come, on the other hand, to investigate the phenomena of afferent nerves, our labours are for the time rendered heavier, but in the end more fruitful, by the facts: First, that we can only judge of what is going on in an afferent nerve by the effects it produces in some central nervous organ, in the way of exciting or modifying reflex action, or modifying automatic action, or affecting consciousness; and we are consequently met on the very threshold of every inquiry by the difficulty of clearly distinguishing the events which belong exclusively to the afferent nerve from those which belong to the central organ. Secondly, that the effects of applying a stimulus to the peripheral end-organ of an afferent nerve are very different from those of applying the same stimulus directly to the nerve-trunk. This may be shewn by the simple experience of comparing the sensation caused by the contact with any sharp body of a nerve laid bare by a wound with that caused by contact of an intact skin with the same body. These differences reveal to us a complexity of impulses, of which the phenomena of motor nerves gave us not so much as a hint; but for the time being they increase the difficulties of our study.

An afferent impulse passing along an afferent nerve may affect unconscious reflex or automatic action, or may produce a change in our consciousness, or may bring about both results at the same time. An afferent nerve the stimulation of which may lead to a modification of consciousness may be more closely defined as a 'sensory' nerve. There is no distinct proof, having regard to the difficulties just mentioned, that the afferent fibres which in the body are commonly

used to cause or affect reflex action differ at all in kind from those whose function it is to modify consciousness. On the contrary, such evidence as we have goes to shew that an appropriate stimulus of the same fibre may give rise to one or other or both events; and that whether the one or the other, or both, events occur depends on the condition of the central organ, and on the relation of its several parts to the afferent nerve. The stimulation of the same nerve (and there are no positive facts which would preclude us from saying 'of the same fibre') may at one moment, when the central nervous system is intact, give rise to a change of consciousness alone, without the development of any reflex action whatever, and at another moment, the cerebrum being meanwhile removed, cause simply a reflex action. We urge this point here because we shall be frequently led to speak of a 'sensory' nerve under circumstances where there is no evidence of consciousness being affected; and though such a use of the word is perhaps etymologically incorrect, the convenience of so using it is a sufficient excuse.

All the **spinal nerves** are mixed nerves, composed of afferent and efferent, of motor and sensory fibres. When a spinal nerve is divided, stimulation of the peripheral portion causes muscular contraction, of the central portion, a sensation (or a reflex action). At the junction of the nerve with the spinal cord the sensory fibres are gathered into the posterior and the motor fibres into the anterior root. The proof of this, which was first made known by Charles Bell and Majendie, their discoveries forming the foundation of modern nervous physiology, is simply as follows.

When the anterior root is divided, the muscles supplied by the nerve cease to be thrown into contractions either by the will, or by reflex action, while the structures to which the nerve is distributed retain their sensibility. During the section of the root, or when the proximal stump, that connected with the spinal cord, is stimulated, no sensory effects are produced. When the distal stump is stimulated, the muscles supplied by the nerve are thrown into contractions. When the posterior root is divided, the muscles supplied by the nerve continue to be thrown into action by an exercise of the will or as part of a reflex action, but the structures to which the nerve is distributed lose the sensibility which they previously possessed. During the section of the root, and when the proximal stump is stimulated, sensory effects are produced. When the distal stump is stimulated no movements are called forth. These facts demonstrate that sensory impulses pass exclusively by the posterior root from the peripheral to the central organs, and that motor impulses pass exclusively by the anterior root from the central to the peripheral organs.

An exception must be made to the above general statement, on account of the so-called recurrent sensibility which is witnessed in conscious mammals, under favourable circumstances. It often happens that when the *peripheral* stump of the divided anterior root is stimulated, signs of

pain are witnessed. These are not caused by the concurrent muscular contractions or cramp which the stimulation occasions, for they remain if the whole trunk of the nerve be divided some little way below the union of the roots above the origins of the muscular branches, so that no contractions take place. They disappear if the posterior root be also cut, and they are not seen if the mixed nerve-trunk be divided close to the union of the roots. The phenomena are probably due to the fact, that bundles of sensory fibres of the posterior root after running a short distance down the mixed trunk turn back and run upwards in the anterior root, and by this recurrent course give rise to the recurrent sensibility. When the anterior root is divided some few fibres in it do not, like the rest, degenerate, and when the posterior root is divided, a few fibres in the anterior root are seen to degenerate like those of the posterior root.

Concerning the **ganglion** on the posterior root, we may say definitely that it is neither a centre of reflex nor of automatic action. Our knowledge concerning its function is almost limited to the fact that it is in some way intimately connected with the nutrition of the nerve. When a mixed nerve-trunk is divided, the peripheral portion degenerates from the point of section downwards towards the periphery. The central portion does not so degenerate, and if the length of nerve removed be not too great, the central portion uniting with the degenerating peripheral portion may grow downwards, and thus regenerate the nerve. This degeneration is observed when the mixed trunk is divided in any part of its course from the periphery to close up to the ganglion. When the posterior root is divided between the ganglion and the spinal cord, the portion attached to the spinal cord degenerates, but that attached to the ganglion remains intact. When the anterior root is divided, the proximal portion in connection with the spinal cord remains intact, but the distal portion between the section and the junction with the other root degenerates; and in the mixed nerve-trunk many degenerated fibres are seen, which, if they be carefully traced out, are found to be motor fibres. If the posterior root be divided carefully between the ganglion and the junction with the anterior root, the posterior root above the section remains intact, but in the mixed nerve-trunk are seen numerous degenerated fibres, which when examined are found to have the distribution of sensory fibres. Lastly, if the posterior ganglion be excised, the whole posterior root degenerates, as do also the sensory fibres of the mixed nerve-trunk. Putting all these facts together, it would seem that the growth of the motor and sensory fibres takes place in opposite directions, and starts from different nutritive or 'trophic' centres. The sensory fibres grow away from the ganglion either towards the periphery, or towards the spinal cord. The motor fibres grow outwards from the spinal cord towards the periphery. This difference in their mode of nutrition is frequently of great help in investigating the relative distribution of motor and sensory fibres. When a posterior root is cut beyond the ganglion, or the ganglion excised, all the sensory nerves degenerate, and the sensory fibres, by

their altered condition, can readily be traced in the mixed nerve-branches. Conversely, when the anterior roots are cut, the motor fibres alone degenerate, and can be similarly diagnosed in a mixed nerve-tract. Thus also in a mixed nerve like the vagus, the fibres which spring from the real vagus root may be distinguished from those proceeding from the spinal accessory, by section of the vagus and spinal accessory roots respectively; and in the mixed vago-sympathetic trunk, met with in many animals, the vagus fibres may be distinguished from the sympathetic, since, after a section of the mixed trunk, the former degenerate from above downwards, whereas the latter degenerate from the inferior cervical ganglion below upwards to the superior cervical ganglion above; for the ganglia of the sympathetic behave in this respect like the spinal ganglia of the posterior roots. This method of diagnosis is often spoken of as the Wallerian method, after A. Waller, to whom we are indebted for the discovery of most of these facts.

According to Wundt¹ afferent impulses suffer a delay in passing through the spinal ganglia, reflex acts having a markedly shorter latent period when they are initiated by a stimulus applied to the posterior root than when the stimulus is applied to the mixed nerve-trunk just below the ganglion.

In the **cranial nerves** the motor and sensory tracts are far less mixed than in the spinal nerves. The olfactory, optic and acoustic nerves are purely sensory nerves. The fifth, glosso-pharyngeal and vagus are mixed nerves. The facial and hypoglossal are for the most part motor (efferent) nerves, but contain sensory fibres. The third, fourth, sixth and spinal accessory are exclusively motor (efferent) nerves. These statements refer to what are commonly looked upon as the trunks of the respective nerves. More exactly speaking, the sensory fibres of the facial come from the fifth, pneumogastric and glosso-pharyngeal nerves, so that the facial proper is in reality a purely motor nerve. So likewise is the hypoglossal, its sensory fibres coming from the fifth, pneumogastric, and three upper cervical nerves. The fifth is a mixed nerve entirely on the plan of a spinal nerve, having distinct motor and sensory roots. The glosso-pharyngeal seems also to be essentially a sensory nerve, its motor filaments springing from the fifth and facial nerves. Concerning the vagus some have maintained that the pneumogastric root proper is entirely sensory (afferent), and that all the efferent functions of the vagus are dependent on the fibres of the spinal accessory which join it. To this point we shall return when we come to consider briefly the special functions of these several nerves.

We have already stated (p. 87) that isolated pieces of motor and of sensory nerves behave exactly alike as far as all the physical manifestations attendant on the passage of a nervous impulse are concerned.

¹ *Mechanik der Nerven.* (1876), 2te Abth. p. 45.

The same is also true, as far as we know, of nerves within the body. This, taken into consideration with the facts just mentioned concerning the regeneration of nerves, suggests the inquiry whether by a change of the peripheral or central organs a motor nerve can be converted into a sensory nerve, or *vice versa*. Experiments made with a view of obtaining a functional union between purely motor and sensory nerves have, in the hands of most observers (Flourens, Bidder, Schiff, &c.), failed; and though Philipeaux and Vulpian¹ were so far more successful, that they obtained an apparent union between a sensory and a motor nerve-trunk, their results do not prove that a fibre, which is ordinarily a purely sensory, may act as a motor fibre, and *vice versa*.

These observers, having in young dogs divided the hypoglossal nerve and removed its central portion as completely as possible, united by fine sutures its peripheral end with the central portion of the lingual of the same side, having similarly removed from this the peripheral portion. Thus the central lingual was united with the peripheral hypoglossal. Complete union took place, and it was found that, after some weeks, the portion of nerve between the tongue and the point of union, *i.e.* the part which had previously been the peripheral hypoglossal, was in a sound and healthy condition. Stimulation of the central parts of the lingual nerve above the point of union produced contractions in the tongue of that side, whether the stimulus were electrical or mechanical; and the contractions were still visible when the lingual, in order to preclude any reflex action, was divided high up previous to stimulation. Here the sensory lingual was evidently the means of causing motor effects. It must be remembered, however, that this is not a case of the union of motor and sensory fibres. The peripheral portion of the hypoglossal in reality became wholly degenerated, and the portion of nerve which apparently was hypoglossal nerve, was in truth new nerve produced by a downward growth of the lingual. If any real union took place it must have been between the lingual fibres and the end-plates of the glossal muscular fibres. The force of this experiment is moreover lessened by the fact, that when the hypoglossal is simply removed, or a large piece of the nerve cut out, so that the peripheral portions degenerate, stimulation of the lingual nerve of the same side causes movements of the tongue², though when the hypoglossal is intact, stimulation of the lingual produces no such effect. The explanation of this result is not obvious. Similar but less satisfactory experiments were made on the union of the vagus and hypoglossal.

The rate at which nervous impulses travel appears to be about the same in motor and sensory nerves. We have seen that the velocity of a nervous impulse in the motor nerve of a frog is about 28 metres per sec. The velocity of a motor impulse in man, as judged by the difference of the latent period of the contraction of the thumb-muscles when stimulation is brought to bear on the motor nerve at the wrist, or high up in the arm, is about 33 metres per sec. In warm-blooded animals, however, the rate of transmission of

¹ Vulpian, *Lec. System Nerv.* 274.

² Brücke, *Vorlesung.* II. 22,

motor impulses is very variable, being in particular closely dependent on temperature, and probably also on other circumstances. Thus, Helmholtz and Baxt¹ obtained a range from as low as 30 m. when the arm was cooled to as high as 89·4 m. when the arm was heated. The velocity of a sensory impulse is estimated by measuring the time taken between a stimulus being brought to bear on some sentient surface, as the skin, and the making of a signal by the individual experimented on at the instant that he feels the stimulus. The time taken up in the sensory impulse becoming converted into a sensation after reaching the nervous central organs, in the mental operation of determining to make the signal, and in the beginning to make the signal, corresponds in a way to the purely muscular portion of the latent period in the experiment for determining the velocity of a motor impulse. The application of the stimulus and the making of the signal (*ex. gr.* closing a galvanic circuit) being both recorded on a rapidly travelling surface, the time taken up in the whole operation can be easily measured; and the difference between the time taken when the stimulus is applied to some spot separated from the central nervous system by a short piece of nerve, *ex. gr.* the top of the thigh, and that taken when a long piece of nerve intervenes, *ex. gr.* when the stimulus is applied to the toe, will give the time required for the sensory impulse to pass along a piece of sensory nerve as long as the difference of length between the above two nerves; from which the velocity can be calculated. Observations carried on in this way led to most discordant results, varying from 26 metres to 94 metres, or even more per sec. The difference here is far too great to allow any value to be attached to an average. When it is remembered how complex are all the central nervous operations in these instances, as compared with the changes going on in a muscle during the latent period of its contraction, and how these central operations might vary according as one or other spot of skin was stimulated, quite independently of the length of nerve between the centre and the spot stimulated, these discrepancies will not be wondered at; and it may fairly be concluded that the velocity of a sensory impulse does not materially differ from that of a motor impulse.

We have already seen (p. 85) that a sensory nerve in its simplest form may be regarded as a strand of eminently irritable protoplasm, forming a link between a superficial cell which alone is subject to extrinsic stimuli, and a central (reflex or automatic) cell which receives stimuli chiefly in the form of nervous impulses proceeding from the former along the connecting strand. In the earliest stages of the development of a sensory nervous system, the superficial sensory cell is susceptible of stimuli of all kinds, provided they are sufficiently strong; and probably all the impulses which it transmits to the central cell resemble each other very closely, differing only in degree. It is obvious however that the economy would

¹ Berlin. Monatsbericht, 1870.

gain by a further division of labour, by a differentiation of the simple uniform superficial cell into a number of cells, each of which was more susceptible to particular stimuli than its fellows. Thus one cell, or rather one group of cells, would become eminently susceptible to the influence of light: in them the impact of rays of light would give rise to nervous impulses more readily than in the other groups; another group would develop a sensitiveness to waves of sound, and so on. In this way the primary homogeneous bodily surface would be differentiated into a series of *sense-organs*, disposed and arranged among ectodermic cells, the purpose of the latter being simply protective, and therefore not demanding the existence of any direct connection with the central nervous system. Similar but less highly marked differentiations would be established in the endings of the afferent nerves connecting the central nervous system with the internal surfaces and parts of the body.

Moreover it is obvious that the sensory impulses transmitted to the central nervous system by these differentiated sense-organs would be themselves largely differentiated. Just as the impulses which pass along a motor nerve differ according to the nature of the stimulus which is applied to the nerve (whether, for instance, the stimulus be a single induction-shock, or several shocks repeated slowly, or several shocks repeated rapidly, and so on, the effect on the muscle being in each case a different one), so to a much greater degree the impulses generated by light in a visual sense-organ must naturally differ from those generated by simple pressure in a tactile sense-organ.

And since these various sensory impulses have much work to perform on arriving at the central nervous system, in the way of affecting consciousness, and influencing the multitudinous molecular operations going on in the central cells, this differentiation of sensory organs and sensory impulses is accompanied by a corresponding differentiation of those central cells which the impulses are the first to reach on arriving at the central organ. Those cells, for instance, of the central nervous system, which first receive the particular nervous impulses coming from the visual sense-organs, will be set apart for the task of so modifying and preparing those impulses as to adapt them in the best possible way for the work which they have to do. Hence each peripheral sense-organ will be united by means of its nerve with a corresponding central sense-organ, the former being able to affect other parts of the central nervous system only through the medium of the latter. This at least we know to be the case as far as relates to all the central nervous operations in which consciousness is concerned; for of the total characters which belong to an affection of consciousness by means of any of the sense-organs, *i. e.* which belong to any particular sensations, while some are gained during the rise of the sensory impulses in the peripheral sense-organ, others first appear in the central sense-organ during the conversion of the impulses into a sensation. Thus a stimulus of any kind applied to the optic nerve along any part of its course gives rise to a sensa-

tion of light, and precisely the same stimulus applied to the acoustic nerve along any part of its course gives rise to a sensation of sound ; and so on. All the evidence we possess goes against the view that an isolated piece of optic nerve differs in function from a similarly isolated piece of acoustic nerve ; such facts as are within our knowledge go to shew that the disturbances generated in a piece of optic nerve by a galvanic current are the same as those generated in a piece of acoustic nerve. We are therefore driven to the conclusion that the difference in this case arises in the central organs.

In all these differentiated sensory mechanisms, or special senses as they are called, we have then to deal with two elements : the peripheral sense-organ, in which we have to study how the special physical agent gives rise to special sensory impulses ; and the central sense-organs, in which our study is confined to the manner in which these special impulses affect consciousness or otherwise modify the operations of the central nervous system. Inasmuch as in a normal body the peripheral organ remains in connection with the central organ, and our study of the special senses is carried on chiefly by subjective observations in which we make use of our own consciousness, it frequently becomes very difficult to distinguish in any given sensation the peripheral from the central element. The two become more distinct, the more complex the sense and the more highly organised the sense-organs. For this reason it will be most convenient to commence our study of the special senses with the sense of vision.

CHAPTER II.

SIGHT.

A ray of light falling on the retina gives rise to what we call a sensation of light; but in order that distinct vision of any object may be gained, an image of the object must be formed on the retina, and the better defined the image the more distinct will be the vision. Hence in studying the physiology of vision, our first duty is to examine into the arrangements by which the formation of a satisfactory image on the retina is effected; these we may call briefly the dioptric mechanisms. We shall then have to inquire into the laws according to which rays of light impinging on the retina give rise to sensory impulses, and those according to which the impulses thus generated give rise in turn to sensations. Here we shall come upon the difficulty of distinguishing between the unconscious or physical and the conscious or psychical factors. And we shall find our difficulties increased by the fact, that in appealing to our own consciousness we are apt to fall into error by confounding primary and direct sensations with states of consciousness which are produced by the weaving of these primary sensations with other operations of the central nervous system, or, in familiar language, by confounding what we see with what we think we see. These two things we will briefly distinguish as visual sensations and visual judgments; and we shall find that both in vision with one eye, but more especially in binocular vision, visual judgments form a very large part of what we frequently speak of as our sight.

SEC. 1. DIOPTRIC MECHANISMS.

The Formation of the Image.

The eye is a camera, consisting of a series of lenses and media arranged in a dark chamber, the iris serving as a diaphragm; and the object of the apparatus is to form on the retina a distinct image of external objects. That a distinct image is formed on the retina, may be ascertained by removing the sclerotic from the back of an

eye, and looking at the hinder surface of the transparent retina while rays of light proceeding from any external object are allowed to fall on the cornea.

A dioptric apparatus in its simplest form consists of two media separated by a (spherical) surface; and the optical properties of such an apparatus depend upon (1) the curvature of the surface, (2) the relative refractive power of the media. The eye consists of several media, bounded by surfaces which are approximately spherical but of different curvature. The surfaces are all centred on a line called the *optic axis*, which meets the retina at a point somewhat above and to the inner (nasal) side of the fovea centralis. In passing from the outer surface of the cornea to the retina the rays of light traverse in succession the cornea, the aqueous humour, the lens and the vitreous humour. Refraction takes place at all the surfaces bounding these several media, but particularly at the anterior surface of the cornea, and at both the anterior and posterior surfaces of the lens. Since the anterior and posterior surfaces of the cornea are parallel, or very nearly so, the rays of light would suffer little or no change of direction in passing through the cornea, if it were bounded on both sides by the same medium. The direction of the rays of light in the aqueous humour would therefore remain the same if the cornea were made exceedingly thin, if in fact its two surfaces were made into one, forming a single anterior surface to the aqueous humour; or, which comes to the same thing in the end, since the refractive power of the substance of the cornea is almost exactly the same as that of the aqueous humour, the refraction at the posterior surface of the cornea may be neglected altogether. Thus the two surfaces of the cornea are practically reduced to one. The lens varies in density in different parts, the refractive power of the central portions being greater than that of the external layers; but the refractive power of the whole may, without any serious error, be assumed to be uniform, a mean being taken between the refractive powers of the several parts. The refractive power of the vitreous humour is almost exactly the same as that of the aqueous humour.

Thus the apparently complicated natural eye may be simplified into a 'diagrammatic eye,' in which the refracting surfaces are reduced to three, viz. (1) the anterior surface of the cornea, (2) the anterior surface of the lens separating the lens from the aqueous humour, and (3) the posterior surface of the lens separating the lens from the vitreous humour. The media will similarly be reduced to two; the mean substance of the lens, and the aqueous or vitreous humour. This 'diagrammatic eye' is of great use in the various calculations which become necessary in studying physiological optics; for the magnitudes which are derived by calculation from it represent the corresponding magnitudes in an average natural eye with sufficient accuracy to serve for all practical purposes. The values adopted by Listing for the constants of this 'diagrammatic eye,' and to him we are indebted for the introduction of it, are as follow :

Radius of curvature of cornea	8 mm.
" " of anterior surface of lens.....	10 "
" " of posterior " " 	6 "
Refractive index of aqueous or vitreous humour.....	$\frac{4}{3}$,
Mean refractive index of lens	$\frac{16}{11}$,
Distance from anterior surface of cornea to anterior surface of lens	4 mm.
Thickness of lens	4 "

The calculated position of the *principal posterior focus*, *i.e.* the point at which all rays falling on the cornea parallel to the optic axis are brought to a focus, is in the diagrammatic eye 14.6470 mm. behind the posterior surface of the lens, or 22.6470 mm. behind the anterior surface of the cornea. That is to say, the fovea centralis must occupy this position in order that a distinct image of a distant object may be formed upon it. It must be understood that these values refer to the eye when at rest, *i.e.* when it is not undergoing any strain of accommodation.

Accommodation.

When an object, a lens, and a screen to receive the image, are so arranged in reference to each other, that the image falls upon the screen in exact focus, the rays of light proceeding from each luminous point of the object are brought into focus on the screen in a point of the image corresponding to the point of the object. If the object be then removed farther away from the lens, the rays proceeding in a pencil from each luminous point will be brought to a focus at a point in front of the screen, and, subsequently diverging, will fall upon the screen as a circular patch composed of a series of circles, the so-called *diffusion circles*, arranged concentrically round the principal ray of the pencil. If the object be removed, not farther, but nearer the lens, the pencil of rays will meet the screen before they have been brought to focus in a point, and consequently will in this case also give rise to diffusion circles. When an object is placed before the eye, so that the image falls into exact focus on the retina, and the pencils of rays proceeding from each luminous point of the object are brought into focus in points on the retina, the sensation called forth is that of a distinct image. When on the contrary the object is too far away, so that the focus lies in front of the retina, or too near, so that the focus lies behind the retina, and the pencils fall on the retina not as points, but as systems of diffusion circles, the image produced is indistinct and blurred. In order that objects both near and distant may be seen with equal distinctness by the same dioptric apparatus, the focal arrangements of the apparatus must be *accommodated* to the distance of the object, either by changing the refractive power of the lens, or by altering the distance between the lens and the screen.

That the eye does possess such a power of accommodation is shewn by every-day experience. If two needles be fixed upright some two

feet or so apart, into a long piece of wood, and the wood be held before the eye, so that the needles are nearly in a line, it will be found that if attention be directed to the far needle, the near one appears blurred and indistinct, and that, conversely, when the near one is distinct, the far one appears blurred. By an effort of the will we can at pleasure make either the far one or the near one distinct; but not both at the same time. When the eye is arranged so that the far needle appears distinct, the image of that needle falls exactly on the retina, and each pencil from each luminous point of the needle unites in a point upon the retina; but when this is the case, the focus of the near needle lies *behind the* retina, and each pencil from each luminous point of this needle falls upon the retina in a series of diffusion circles. Similarly, when the eye is arranged so that the near needle is distinct, the image of that needle falls upon the retina in such a way, that each pencil of rays from each luminous point of the needle unites in a point on the retina, while each pencil from each luminous point of the far needle unites at a point *in front of* the retina, and then diverging again falls on the retina, in a series of diffusion circles. If the near needle be gradually brought nearer and nearer to the eye, it will be found that greater and greater effort is required to see it distinctly, and at last a point is reached at which no effort can make the image of the needle appear anything but blurred. The distance of this point from the eye marks *the limit* of accommodation for near objects. Similarly, if the person be short-sighted, the far needle may be moved away from the eye, until a point is reached at which it ceases to be seen distinctly, and appears blurred. In the one case, the eye, with all its power, is unable to bring the image of the needle sufficiently forward to fall on the retina; the focus lies permanently behind the retina. In the other, the eye cannot bring the image sufficiently backward to fall on the retina; the focus lies permanently in front of the retina. In both cases the pencils of rays from the needles strike the retina in diffusion circles.

The same phenomena may be shewn with greater nicety by what is called Scheiner's experiment¹. If two smooth holes be pricked in a card, at a distance from each other less than the diameter of the pupil, and the card be held up before one eye, with the holes horizontal, and a needle placed vertically be looked at through the holes, the following facts may be observed. When attention is directed to the needle itself, the image of the needle appears single. Whenever the gaze is directed to a more distant object, so that the eye is no longer accommodated for the needle, the image appears double and at the same time blurred. It also appears double and blurred when the eye is accommodated for a distance nearer than that of the needle. When only one needle is seen, and the eye therefore is properly accommodated for the distance of the needle, no effect is produced by blocking up one hole of the card, except that the whole

¹ Scheiner, *Oculus*. Innsbruck, 1619.

field of vision seems dimmer. When, however, the image is double on account of the eye being accommodated for a distance greater than that of the needle, blocking the left-hand hole causes a disappearance of the right-hand or opposite image, and blocking the right-hand hole causes the left-hand image to disappear. When the eye is accommodated for a distance nearer than that of the needle, blocking either hole causes the image on the same side to vanish. The following diagram will explain how these results are brought about.

Let a (Fig. 44) be a luminous point in the needle, and ae, af the extreme right-hand and left-hand rays of the pencil of rays proceeding

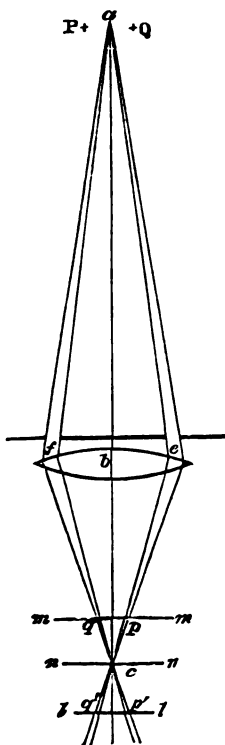

FIG. 44. DIAGRAM OF SCHEINER'S EXPERIMENT.

from it, and passing respectively through the right-hand e , and left-hand f , holes in the card. (The figure is supposed to be a horizontal section of the eye.) When the eye is accommodated for a , the rays e and f meet together in the point c , the retina occupying the position of the plane mn ; the luminous point appears as one point, and the needle will appear as one needle. When the eye is accommodated

for a distance beyond a , the retina may be considered to lie¹ no longer at mn , but nearer the lens, at mm for example; the rays ae will cut this plane at p , and the rays af at q ; hence the luminous point will no longer appear single, but will be seen as two points, or rather as two systems of diffusion circles, and the single needle will appear as two blurred needles. The rays passing through the right-hand hole e , will cut the retina at p , *i. e.* on the right-hand side of the optic axis; but, as we shall see in speaking of the judgments pertaining to vision, the image on the right-hand side of the retina is *referred by the mind* to an object on the left-hand side of the person; hence the affection of the retina at p , produced by the rays ae falling on it there, gives rise to an image of the spot a at P , and similarly the left-hand spot q corresponds to the right-hand Q . Blocking the left-hand hole, therefore, causes a disappearance of the right-hand image, and *vice versa*. Similarly when the eye is accommodated for a distance nearer than the needle, the retina may be supposed to be removed to ll , and the right-hand ae and left-hand af rays, after uniting at c , will diverge again and strike the retina at p' and q' . The blocking of the hole e will now cause the disappearance of the image q' on the left-hand side of the retina, and this will be referred by the mind to the right-hand side, so that Q will seem to vanish.

If the needle be brought gradually nearer and nearer to the eye, a point will be reached within which the image is always double. This point marks with considerable exactitude the near limit of accommodation. With short-sighted persons, if the needle be removed farther and farther away, a point is reached beyond which the image is always double; this marks the far limit of accommodation.

The experiment may also be performed with the needle placed horizontally, in which case the holes in the card should be vertical. The adjustment for the eye for near or far distances may be assisted by using two needles, one near and one far. In this case one needle should be vertical and the other horizontal, and the card turned round so that the holes lie horizontally or vertically according to whether the vertical or horizontal needle is being made to appear double.

In what may be regarded as the normal eye, the so-called *emmetropic* eye, the near limit of accommodation is about 10 or 12 cm. and the far limit may be put for practical purposes at an infinite distance. The 'range of distinct vision' therefore for the emmetropic eye is very great. In the *myopic*, or short-sighted eye, the near limit is brought much closer (5 or 6 cm.) to the cornea; and the far limit is at a variable but not very great distance, so that the rays of light proceeding from an object not many feet away are brought to a focus, not on the retina but in the vitreous humour. The range of distinct vision is therefore in the myopic eye very limited. In the *hyperme-*

¹ Of course, in the actual eye, as we shall see, accommodation is effected by a change in the lens, and not by an alteration in the position of the retina; but for convenience sake, we may here suppose the retina to be moved.

tropic, or long-sighted eye, the rays of light coming from even an infinite distance are, in the passive state of the eye, brought to a focus beyond the retina. The near limit of accommodation is at some distance off, and a far limit of accommodation does not exist. The *presbyopic* eye, or the long-sight of old people, resembles the hypermetropic eye in the distance of the near point of accommodation, but differs from it inasmuch as the former is an essentially defective condition of the accommodation mechanism, whereas in the latter the power of accommodation may be good and yet, from the internal arrangements of the eye, be unable to bring the image of a near object on to the retina. When a normal eye becomes presbyopic, the far limit may remain the same, but since the power of accommodating for near objects is weakened or lost, the change is distinctly a reduction of the range of distinct vision. In the normal emmetropic eye, when no effort of accommodation is made, the principal focus of the eye lies on the retina, in the myopic eye in front of it, and in the hypermetropic eye behind it.

Mechanism of Accommodation. In directing our attention from a far to a very near object we are conscious of a distinct effort, and feel that some change has taken place in the eye; when we turn from a very near to a far object, if we are conscious of any change in the eye, it is one of a different kind. The former is the sense of an active accommodation for near objects; the latter, when it is felt, is the sense of relaxation after exertion.

Since the far limit of an emmetropic eye is at an infinite distance, no such thing as active accommodation for far distances need exist. The only change that will take place in the eye in turning from near to far objects will be a mere passive undoing of the accommodation previously made for the near object. And that no such active accommodation for far distances takes place is shewn by the facts—that the eye, when opened after being closed for some time, is found not in medium state but adjusted for distance; that when the accommodation mechanism of the eye is paralysed by atropin or nervous disease, the accommodation for distant objects is unaffected; and that we are conscious of no effort in turning from moderately distant to far distant objects. The sense of effort often spoken of by myopic persons as being felt when they attempt to see things at or beyond the far limit of their range seems to arise from a movement of the eyelids, and not from any internal changes taking place in the eye.

What then are the changes which take place in the eye, when we accommodate for near objects? It might be thought, and indeed once was thought, that the curvature of the cornea was changed, becoming more convex, with a shorter radius of curvature, for near objects. Young, however, shewed that accommodation took place as usual when the eye (and head) is immersed in water. Since the refractive powers of aqueous humour and water are very nearly alike, the cornea, with its parallel surfaces, placed between these two fluids,

can have little or no effect on the direction of the rays passing through it when the eye is immersed in water. And accurate measurements of the dimensions of an image on the cornea have shewn that these undergo no change during accommodation, and that therefore the curvature of the cornea is not altered. Nor is there any change in the form of the bulb; for any variation in this would necessarily produce an alteration in the curvature of the cornea, and pressure on the bulb would act injuriously by rendering the retina anæmic and so less sensitive. In fact, there are only two changes of importance which can be ascertained to take place in the eye during accommodation for near objects.

One is that the pupil contracts. When we look at near objects, the pupil grows small; when we turn to distant objects, it dilates. This however cannot have more than an indirect influence on the formation of the image; the chief use of the contraction of the pupil in accommodation for near objects is to cut off the more divergent circumferential rays of light.

The other and really efficient change is that the anterior surface of the lens becomes more convex. If a light be held before the eye, three reflected images may be seen by a bystander: one a very bright one caused by the anterior surface of the cornea, a second less bright, by the anterior surface of the lens, and a third very dim, by the posterior surface of the lens. When the eye is accommodated for near objects, no change is observed in either the first or the third of these images; but the second, that from the anterior surface of the lens, is seen to become distinctly smaller, shewing that the surface has become more convex. When, on the contrary, vision is directed from near to far objects, the image from the anterior surface of the lens grows larger, indicating that the convexity of the surface has diminished, while no change takes place in the curvature either of the cornea or of the posterior surface of the lens. And accurate measurements of the size of the image from the anterior surface of the lens have shewn that the variations in curvature which do take place, are sufficient to account for the power of accommodation which the eye possesses.

The observation of these reflected images is facilitated by the simple instrument introduced by Helmholtz and called a Phakoscope. It consists of a small dark chamber, with apertures for the observed and observing eyes; a needle is fixed at a short distance in front of the former, to serve as a near object, for which accommodation has to be made; and by means of two prisms the image from each of the three surfaces of the observed eye is made double instead of single. When the anterior surface of the lens becomes more convex the two images reflected from that surface approach each other, when it becomes less convex they retire from each other. The approach and retirement are more readily appreciated than is a simple change of size.

These observations leave no doubt that the essential change by which accommodation is effected, is an alteration of the convexity of

the anterior surface of the lens. And that the lens is the agent of accommodation, is shewn by the fact that after removal of the lens, as in the operation for cataract, the power of accommodation is lost.

In the cases which have been recorded, where eyes from which the lens had been removed seemed still to possess some accommodation, we must suppose that no real accommodation took place, but that the pupil contracted when a near object was looked at, and so assisted in making vision more distinct.

Concerning the nature of the mechanism by which this increase of the convexity of the lens is effected, the view most generally adopted is as follows. In the passive condition of the eye, when it is adjusted for far objects, the suspensory ligament keeps the lens tense with its anterior surface somewhat flattened. Accommodation for near objects consists essentially in a contraction of the ciliary muscle, which, by pulling forward the choroid coat and the ciliary processes, slackens the suspensory ligament, and allows the lens to bulge forward by virtue of its elasticity, and so to increase the convexity of its anterior surface.

Though all the parts surrounding the lens are highly vascular, the change in the lens cannot be considered as the result of any vaso-motor action, since accommodation may be effected in a practically bloodless eye by artificial stimulation with an interrupted current, or by other means. Again, the fact that accommodation may take place in eyes from which the iris is congenitally absent, disproves the suggestion that the change in the lens is caused either by the compression of the circumference of the lens, or in any other way by contraction of the iris. On the other hand, the observations of Hensen and Völckers¹, who saw the choroid drawn forward during accommodation, and satisfied themselves that the cornea served as a functional fixed attachment for the ciliary muscle, offer a strong support to the generally accepted explanation. To which it may be added, that the lens is certainly elastic, and, moreover, that its natural convexity appears to be diminished by the action of the suspensory ligament, since after removal from the body its anterior surface is found to be more convex than when in the natural position in the body.

Accommodation is a voluntary act; since, however, the change in the lens is always accompanied by movements in the iris, it will be convenient to consider the latter, before we discuss the nervous mechanism of the whole act.

Movements of the Pupil. Though by making the efforts required for accommodation we can at pleasure contract or dilate the pupil, it is not in our power to bring the will to act directly on the iris by itself. This fact alone indicates that the nervous mechanism of the pupil is of a peculiar character, and such indeed we find it to be. The pupil is *contracted* (1) when we accommodate for near objects, (2) when the retina (or optic nerve) is stimulated, as when light falls

¹ *Mechanismus d. Accommod.* 1868. *Cbt. f. Med. Wiss.* 1868, p. 455.

on the retina; the brighter the light the greater the contraction. The pupil is also contracted when the eyeball is turned inwards, when the aqueous humour is deficient, in the early stages of poisoning by chloroform, alcohol, &c., and in nearly all stages of poisoning by morphia, calabar bean, and some other drugs. The pupil is *dilated* (1) when the eye is adjusted for far objects, (2) when stimulation of the retina (or optic nerve) is arrested or diminished. Hence the pupil dilates in passing into a dim light. Dilation also occurs when there is an excess of aqueous humour, during dyspnoea, during violent muscular efforts, as an effect of emotions, in the later stages of poisoning by chloroform &c., and in all stages of poisoning by atropin and some other drugs. Contraction of the pupil is caused by contraction of the circular fibres or sphincter of the iris. Dilation is caused by contraction of the radial fibres of the iris.

The existence of radial fibres has been denied by many observers, but the preponderance of evidence is clearly in favour of their being really present. Considering how vascular the iris is, it does not seem unreasonable to interpret some of the variations in the condition of the pupil as the results of simple vascular turgescence or depletion brought about by vaso-motor action or otherwise. Thus slight oscillations of the pupil may be observed synchronous with the heart-beat and others synchronous with the respiratory movements. But that constriction of the pupil cannot be wholly the result of turgescence, nor dilation wholly the result of depletion of the vessels of the iris, is shewn by the fact that both these events may be witnessed in a perfectly bloodless eye.

Contraction of the pupil, brought about by light falling on the retina, is a reflex act, of which the optic is the afferent nerve, the third or oculo-motor the efferent nerve, and the centre some portion of the corpora quadrigemina in the neighbourhood of the aqueduct of Sylvius. This is proved by the following facts. When the optic nerve is divided, the falling of light on the retina no longer causes a contraction of the pupil. When the third nerve is divided, stimulation of the retina or of the optic nerve no longer causes contraction; but direct stimulation of the peripheral portion of the divided third nerve causes extreme contraction of the pupil. After removal of the corpora quadrigemina, stimulation of the retina is similarly ineffectual. But if the corpora quadrigemina, optic nerve, and third nerve be left intact, contraction of the pupil will occur as a result of light falling on the retina, though all other nervous parts be removed, certain reservations, of which we shall speak directly, being made.

In the excised eye of the eel or frog the pupil will still contract on exposure to light though the nervous centre is absent¹. Holmgren and Edgren² find that in the frog this contraction of the pupil of the excised eye on exposure to light disappears when the retina is destroyed; there

¹ Brown-Séquard, *Compt. Rend.* xxv. (1847), 482, 508, *Proc. Roy. Soc.* viii. (1856), p. 233.

² Hofmann and Schwalbe, *Bericht*, v. (1876), p. 103.

seems therefore to be *within the bulb* some nervous connection between the retina and iris.

The centre in the corpora quadrigemina is not a double centre with two completely independent halves, one for each eye; there is a certain amount of functional communion between the two sides, so that when one retina is stimulated both pupils contract. It might be imagined that this cerebral centre acted as a tonic centre, whose action was simply increased not originated by the stimulation of the retina. This, however, is disproved by the fact that, if the optic nerve be divided, subsequent section of the third nerve produces no further effect.

In considering the movements of the pupil, however, we have to deal not only with contraction but with active dilation; and this renders the whole matter much more complex than might be supposed to be the case from the simple statement just made.

The iris is supplied, in common with the ciliary muscle and choroid, by the short ciliary nerves coming from the ophthalmic or lenticular (ciliary) ganglion, which is connected by its roots with the third nerve, the cervical sympathetic nerve, and, by the nasal branch of its ophthalmic division, with the fifth nerve. The short ciliary nerves are, moreover, accompanied by the long ciliary nerves coming from the same nasal branch of the ophthalmic division of the fifth nerve. What are the uses of these several nerves in relation to the pupil?

If the cervical sympathetic in the neck be divided, all other portions of the nervous mechanism being intact, a contraction of the pupil (not always very well marked) takes place, and if the peripheral portion (*i. e.* the upper portion still connected with the eye) be stimulated, a well-developed dilation is the result. The sympathetic has, it will be observed, an effect on the iris, the opposite of that which it exercises on the blood-vessels; when it is stimulated the pupils are dilated while the blood-vessels are constricted. This dilating influence of the sympathetic may, as in the case of the vaso-motor action of the same nerve, be traced back down the neck, along the rami communicantes and roots of the last cervical and first dorsal spinal nerves, to a region in the lower cervical and upper dorsal cord (called by Budge the *centrum cilio-spinale inferius*), and from thence to the medulla oblongata or to the quadrigemina to a centre, the position of which is not accurately known.

The dilation of the pupil cannot however be regarded as a vaso-motor effect (even on the supposition that the emptying or constriction of the blood-vessels of the iris could cause adequate dilation of the pupil)¹, since it may be brought about in the entire absence of the circulation, and since when the sympathetic is stimulated the dilation of the pupil begins before the contraction of the blood-vessels, and may be over before this has arrived at its maximum. We are driven to conclude that the dilating sympathetic fibres do not end in blood-vessels, but are connected either directly or indirectly with the muscular fibres of the dilator.

¹ Cf. Mosso, *Sui movimenti idraulici dell' iride*. Turin, 1875.

The pupil then seems to be under the dominion of two antagonistic mechanisms: one a contracting mechanism, reflex in nature, the third nerve serving as the efferent, and the optic as the afferent tract; the other a dilating mechanism, tonic in nature, of which the cervical sympathetic is the efferent channel. Hence, when the third or optic nerve is divided, not only does contraction of the pupil cease to be manifest, but active dilation occurs, on account of the tonic dilating influence of the sympathetic being left free to work. When, on the other hand, the sympathetic is divided, this tonic dilating influence falls away, and contraction results. When the third or optic nerve is stimulated, the dilating effect of the sympathetic is overcome, and contraction results; and when the sympathetic is stimulated, the contracting influence of the third nerve is overcome, and dilation ensues.

But there are considerations which shew that the matter is still more complex than this. A small quantity of atropin introduced into the eye or into the system causes a dilation of the pupil. This might be attributed to a paralysis of the third nerve, and indeed it is found that after atropin the falling of light on the retina no longer causes contraction of the pupil. A difficulty however is introduced by the fact that when the third nerve is divided, and when therefore the contracting effects of stimulation of the retina are placed entirely on one side, and there is nothing to prevent the sympathetic producing its dilating effects to the utmost, dilation is still further increased by atropin. When calabar bean is introduced into the eye or system, contraction of the pupil is caused, whether the third nerve be divided or not; and when the dose is sufficiently strong the contraction is so great that it cannot be overcome by stimulation of the sympathetic. The dilation which is caused by a sufficient dose of atropin is greater than that which can ordinarily be produced by stimulation of the sympathetic, and the contraction caused by a sufficient dose of calabar bean is greater than that which is ordinarily produced by stimulation of the optic nerve. Evidently these drugs act on some local mechanism, the one in such a way as to cause dilation, the other in such a way as to cause contraction. Such a local mechanism cannot however lie in the ophthalmic ganglion, for both drugs produce these effects in a most marked degree after the ganglion has been excised. We must suppose therefore that the mechanism is situated in the iris itself or in the choroid, where indeed ganglionic nerve-cells are abundant. But if we admit the existence of such a local mechanism, we must further admit that both the sympathetic and the third nerve act not directly on either the sphincter or dilator pupillæ, but indirectly through means of the local nervous mechanism.

The share of the fifth nerve in the work of the iris seems to be in part a sensory one; the iris is sensitive, and the sensory impulses which are generated in it pass from it along the fibres of the fifth nerve.

Though the ophthalmic ganglion does receive fibres directly from the cavernous plexus of the sympathetic, the dilating action of the sympathetic would seem to be carried out not by these fibres but by fibres joining the ophthalmic branch of the fifth nerve higher up in its course and passing to the iris apparently by the long ciliary nerves. According to Oehl¹

¹ Henle and Meissner's *Bericht*, 1862, p. 506.

when these fibres, which appear to run along side the ophthalmic branch rather than actually to become part of the nerve, are destroyed, stimulation of the sympathetic in the neck produces no dilation of the pupil whatever. Section of the ophthalmic branch itself causes contraction, and stimulation of the peripheral end dilation of the pupil; and the effects are still seen after the sympathetic fibres have become degenerated in consequence of the removal of the superior cervical ganglion. From these facts Oehl infers that the fifth nerve itself contains dilating fibres, and he believes that these take their origin from the Gasserian ganglion. Oehl's results, independently arrived at by Rosenthal¹, were conducted on dogs and rabbits. Guttmann² came to a similar conclusion as regards frogs; he found the dilator fibres of the cervical sympathetic passed through the Gasserian ganglion and were there reinforced by fibres taking origin in the ganglion itself. These dilating fibres of the fifth nerve have however been thought by some to be vaso-motorial in nature, producing changes in the pupil in an indirect way by affecting its blood-supply.

When atropin is applied locally so as to affect the pupil of one eye only, the large amount of light entering through the dilated pupil may cause a contraction of the pupil of the other eye.

The movements of the pupil may be brought about through reflex action by sensory impulses other than those arising in the retina or optic nerve. Holmgren³ finds that in rabbits, after section of the optic nerve, dilation of the pupil follows upon the hearing a noise, and indeed upon any sufficiently acute sensation.

We have already stated that when we accommodate for near objects the pupil is contracted; the one movement is 'associated' with the other, that is to say, the special central nervous mechanism employed in carrying out the one act is so connected by nervous ties of some kind or other with that employed in carrying out the other, that when we set the one mechanism in action we unintentionally set the other in action also. A similar associated contraction of the pupil occurs when the eye is directed inward. Conversely, the drugs which have a special action on the pupil, such as atropin and calabar bean, also affect the mechanism of accommodation. Atropin paralyses it, so that the eye remains adjusted for far objects; and calabar bean throws the eye into a condition of forced accommodation for near objects. The latter effect may be explained, on the view stated above, by supposing that the calabar bean throws the ciliary muscle into a state of tetanic contraction in the same way that it does the sphincter pupillæ.

We can accommodate at will; but few persons can effect the necessary change in the eye unless they direct their attention to some near or far object, as the case may be, and thus assist their will by visual sensations. By practice, however, the aid of external objects may be dispensed with; and it is when this is achieved that the pupil may seem to be made to dilate or contract at pleasure,

¹ See Guttmann, *Centralblatt f. Med. Wiss.* 1864, p. 598.

² *Op. cit.*

³ *Loc. cit.*

accommodation being effected without the eye being turned to any particular object.

Imperfections in the Dioptric Apparatus.

The emmetropic eye may be taken as the normal eye. The myopic and hypermetropic eyes may be considered as imperfect eyes, though the former possesses certain advantages over the normal eye. An eye might be myopic from too great a convexity of the cornea, or of the anterior surface of the lens, or from permanent spasm of the accommodation-mechanism, or from too great a length of the long axis of the eyeball. According to Donders the last is the usual cause. Similarly, most hypermetropic eyes possess too short a bulb. The presbyopic eye is, as we have seen, an eye normally constituted in which the power of accommodation has been lost or is failing.

Spherical Aberration. In a spherical lens the rays which impinge on the circumference are brought to a focus sooner than those which pass nearer the centre, and the focus of a luminous point, ceasing to be a point, is spread over a surface. Hence when rays are allowed to fall on the whole of the lens, the image formed on a screen placed in the focus of the more central rays is blurred by the diffusion-circles caused by the circumferential rays which have been brought to a premature focus. In an ordinary optical instrument spherical aberration is obviated by a diaphragm which shuts off the more circumferential rays. In the eye the iris is an adjustable diaphragm; and when the pupil contracts in near vision the more divergent rays proceeding from a near object, which tend to fall on the circumferential parts of the lens, are cut off. As, however, the refractive power of the lens does not increase regularly and progressively from the centre to the circumference, but varies most irregularly, the purpose of the narrowing of the pupil cannot be simply to obviate spherical aberration; and indeed the other optical imperfections of the eye are so great, that such spherical aberrations as are caused by the lens produce no obvious effect on vision.

Astigmatism. We have hitherto treated the eye as if its dioptric surfaces were all parts of perfect spherical surfaces. In reality this is rarely the case, either with the lens or with the cornea. Slight deviations do not produce any marked effect, but there is one deviation tolerably common to a certain extent in most eyes, and very largely developed in some, known as regular astigmatism. This exists when the dioptric surface is not spherical but more convex along one meridian than another, more convex, for instance, along the vertical than along the horizontal meridian. When this is the case the rays proceeding from a luminous point are not brought to a single focus at a point, but possess two linear foci, one nearer than the normal focus and corresponding to the more convex surface, the other farther than the normal and corresponding to the less convex surface. If

the vertical meridians of the surface be more convex than the horizontal, then the nearer linear focus will be horizontal and the farther linear focus will be vertical, and *vice versa*. (This can be shewn much more effectually on a model than in a diagram, in which we are limited to two dimensions.) Now, in order to see a vertical line distinctly, it is much more important that the rays which diverge from the line in the series of horizontal planes should be brought to a focus properly than those which diverge in the vertical plane of the line itself; and similarly, in order to see a horizontal line distinctly it is much more important that the rays which diverge from the line in the series of vertical planes should be brought to a focus properly than those which diverge in the horizontal plane of the line itself. Hence a horizontal line held before an astigmatic dioptric surface, most convex in the vertical meridians, will give rise to the image of a horizontal line at the nearer focus, the vertical rays diverging from the line being here brought to a linear horizontal focus. Similarly, a vertical line held before the same surface will give rise to an image of a vertical line at the farther focus, the horizontal rays diverging from the vertical line being here brought to a linear vertical focus. In other words, with a dioptric surface most convex in the vertical meridians, horizontal lines are brought to a focus sooner than are vertical lines.

Most eyes are thus more or less astigmatic, and generally with a greater convexity along the vertical meridians. If a set of horizontal or vertical lines be looked at, or if the near point of accommodation be determined by Scheiner's experiment (p. 400), for the needle placed first horizontally and then vertically, the horizontal lines or needle will be distinctly visible at a shorter distance from the eye than the vertical lines or needle. Similarly, the vertical line must be farther from the eye than a horizontal one, if both are to be seen distinctly at the same time. The cause of astigmatism is, in the great majority of cases, the unequal curvature of the cornea; but sometimes the fault lies in the lens, as was the case with Young.

When the curvature of the cornea or lens differs not in two meridians only but in several, irregular astigmatism is the result. A certain amount of irregular astigmatism exists in most lenses, thus causing the image of a bright point, such as a star, to be not a circle but a radiate figure.

Chromatic Aberration. The different rays of the spectrum are of different refrangibility, those towards the violet end of the spectrum being brought to a focus sooner than those near the red end. This in optical instruments is obviated by using compound lenses made up of various kinds of glass. In the eye we have no evidence that the lens is so constituted as to correct this fault; still the total dispersive power of the instrument is so small, that such amount of chromatic aberration as does exist attracts little notice. Nevertheless some slight aberration may be detected by careful observation. When the spectrum is observed at some distance the violet end will

not be seen in focus at the same time as the red. If a luminous point be looked at through a narrow orifice covered by a piece of violet glass, which while shutting out the yellow and green allows the red and blue rays to pass through, there will be seen alternately an image having a blue centre with a red fringe, or a red centre with a blue fringe, according as the image of the point looked at is thrown on one side or other of the true focus. Thus supposing f (Fig. 45)

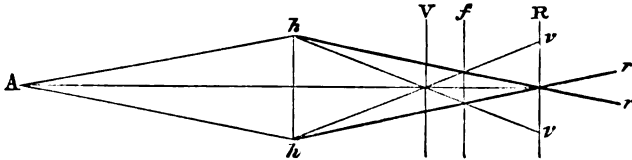

FIG. 45. DIAGRAM ILLUSTRATING CHROMATIC ABERRATION.

hh is the dioptric surface, hv represents the blue, and hr the red rays; V is the focal plane of the blue, R of the red rays.

to be the plane of the mean focus of A , the violet rays will be brought to a focus in the plane V , and the red rays in the plane R ; if the rays be supposed to fall on the retina between V and f , the diverging or blue rays will form a centre surrounded by the still converging red rays; whereas if the rays fall on the retina between f and R , the converging red rays will form a centre with the still diverging blue rays forming a fringe round them; when the object is in focus at f , the two kinds of rays will be mixed together.

Entoptic Phenomena. The various media of the eye are not uniformly transparent; the rays of light in passing through them undergo local absorption and refraction, and thus various shadows are thrown on the retina, of which we become conscious as imperfections in the field of vision, especially when the eye is directed to a uniformly illuminated surface. These are spoken of as entoptic phenomena, and are very varied, many forms having been described.

The most common are those caused by the presence of floating bodies in the vitreous humour, the so-called *muscæ volitantes*. These are readily seen when the eye is turned towards a uniform surface, and are frequently very troublesome in looking through a microscope. They assume the form of rows and groups of beads, of single beads, of streaks, patches and granules, and may be recognised by their almost continual movement, especially when the head or eye is moved up and down. When an attempt is made to fix the vision upon them, they immediately float away. Tears on the cornea, temporary unevenness on the anterior surface of the cornea after the eyelid has been pressed on it, and imperfections in the lens or its capsule, also give rise to visual images. Not unfrequently a radiate figure corresponding to the arrangement of the fibres of the lens makes its appearance.

Imperfections in the margin of the pupil appear in the shadow of the iris which bounds the field of vision; and the movements of the iris in one eye may be rendered visible by alternately closing and opening the other; the field of the first may be observed to contract when light enters, and to expand when the light is shut off from the second. The media of the eye are fluorescent; a condition which favours the perception of the ultra-violet rays. If a white sheet or white cloud be looked at in daylight through a Nicol's prism, a somewhat bright double cone or double tuft, with the apices touching, of a faint blue colour, is seen in the centre of the field of vision, crossed by a similar double cone of a somewhat yellow darker colour. These are spoken of as Haidinger's brushes; they rotate as the prism is rotated, and are supposed to be due to the unequal absorption of the polarized light in the yellow spot. The prism must be frequently rotated, as when the prism remains at rest the phenomena fade. Lastly, according to Helmholtz, the optical arrangements have a further imperfection in that the dioptric surfaces are not truly centred on the optic axis.

SEC. 2. VISUAL SENSATIONS.

Light falling on the retina gives rise to *sensory impulses*, which passing up the optic nerve through certain parts of the brain, and becoming, as we have reason to believe, modified in various cerebral structures, finally affect our consciousness, and call forth *sensations*. In a sensation we ought to be able to distinguish between the events through which the impact of the rays of light on the retina is enabled to generate sensory impulses, and the events, or rather series of events, through which these sensory impulses (for, judging by the analogy of motor nerves, we have no reason to think that they undergo any fundamental changes in passing along the optic nerve), by the agency of the cerebral arrangements, are converted into a sensation. Such an analysis, however, is at present at least, in most particulars, quite beyond our power; and we must therefore treat of the sensations as a whole, distinguishing between the peripheral and central phenomena, on the rare occasions when we are able to do so.

Holmgren¹ and Dewar and McKendrick² have shewn that the natural electric currents of the optic nerve, viz those witnessed when the electrodes are placed on the retina and on points of the longitudinal surface of the optic nerve respectively, undergo a change, sometimes negative but sometimes positive, or according to the latter observers, always positive when light falls on the retina. Stimulation of the retina by light therefore produces in the optic nerve, as does ordinary stimulation in a motor nerve, a change in the natural nerve-currents. This is almost the only objective information we possess concerning the production of optical sensory impulses. Dewar and McKendrick have further shewn that the amount of change in the electrical current varies with the strength of the stimulus, obeying approximately, but not precisely, a law which

¹ *Centrbt. Med. Wiss.* 1871, 423, 438.

² *Trans. Roy. Soc. Edin.* 1873.

regulates the relations of not only optical but all sensations to the stimulus which produces them, and which we shall presently speak of as Fechner's law.

Visual Purple. The recent discovery that the outer layer of the retina (outer limbs of the rods) is normally coloured with a purple colour, which is bleached or destroyed by exposure to light and restored by rest in the dark, seemed at first destined to prove a momentous step in advance as regards our knowledge of the origination of visual impulses. Especially did this seem to be the case when the visual purple was found to be so sensitive that an image could be fixed on the retina after the fashion of a photograph. The subsequent discovery that the colour (which is almost if not exclusively confined to the rods and absent from the cones) does not in man exist in the fovea centralis, where vision is most distinct, and that some animals, at all events (frogs), can see very well indeed in the total absence of their visual purple, shews how much further knowledge is required before any definite statement can be made concerning the function of this colouring matter.

As long ago as 1839 Krohn called attention to the rose colour of the retinas of cephalopods; but though his observations were confirmed by Max Schultze and others, and though some years afterwards H. Müller, and Leydig and Max Schultze, found a similar colouration in the retinas of frogs and other vertebrates, the matter did not attract any great interest until Boll¹ discovered that this colour was susceptible to light, being bleached when the eye was exposed to light but returning again when the eye was kept in the dark. He found that when the eye of a frog which had been kept for some time in the dark was rapidly opened, the outer limbs of the rods of the retina presented a very beautiful purple, or (as he afterwards preferred to call it) red colour, which after a few seconds' exposure to light changed into a yellow and finally disappeared, leaving the rods colourless. Scattered among these red or purple rods were a number of bright green rods, the colour of which also faded on exposure to light. If the frog had previously been exposed for some time to a bright light, the retina, even with the most rapid manipulation, was found to be colourless. And by examining at intervals the eyes of a series of frogs which after being kept in the dark had been exposed to light for variable periods, and conversely of frogs which, after an exposure to bright light, had been kept in the dark for variable periods, Boll was enabled to satisfy himself that, in the living eye at all events, the colour of the rods was destroyed by exposure to light and restored by rest in the dark. Using under similar circumstances monochromatic instead of white light, he came to the conclusion that under exposure to green light the retina became first purple then violet, and finally colourless; under blue and violet light, it first suffered a change to violet and finally lost all colour; while under red light it became a deeper red, under yellow light a brighter red, and when exposed to the ultra-violet rays underwent very little change. He found this visual purple or visual red in the outer limbs of the rods not

¹ Berlin. *Sitzungsberichte*, 1876, *Sitzung*. Nov. 12, 1877, *Sitzung*. Jan. 11. Du Bois-Reymond's *Archiv*, 1877, p. 4.

only of the frog, but of all other vertebrates, including mammalia, whose retinas contain sufficiently conspicuous rods. He concluded that the colour must be largely concerned in the act of vision.

Kühne¹ taking up and largely extending Boll's discovery has been led to the following results:

The colour of the rods is due to the presence of a distinct pigment, the visual purple, which may be extracted from the substance of the rods by dissolving these in an aqueous solution of bile salts. A clear purple solution is thus obtained, which is capable of being bleached by the action of light, and in its general features and behaviour is similar to the pigment as it naturally exists in the retina.

Visual purple is found exclusively in the outer limbs of the rods; it has never yet been found in the cones, and it is accordingly absent from the retinas of animals (such as those of snakes) which are composed of cones only, and from the macula lutea and fovea centralis of the retinas of man and the ape. The intensity of the colouration varies in different animals, and the retinas even of some animals possessing rods (bat, dove, hen) seem to be wholly devoid of the visual purple; it is generally well marked in retinas in which the outer limbs of the rods are well developed. Its absence or presence is not dependent on nocturnal habits, since the intense colour of the retina of the owl is in strong contrast to the absence of colour in the bat. It has been found in the retina of a sheep's embryo. As a general rule the amount of pigment present may be said to be in inverse ratio to the development of coloured 'globules' or 'lenses' in the rods and cones; but it would be premature to insist on any exact relation.

The visual purple is bleached not only by white but also by monochromatic light; the change however in the latter is slower than in the former. Of the various prismatic rays the most active are the greenish yellow rays, those to the blue side of these coming next, the least active being the red. Now it is precisely the greenish yellow rays which are most readily absorbed by the colour itself. A natural coloured retina or a solution of visual purple gives a diffuse spectrum without any defined absorption bands, and according to the amount of colouring material through which the light passes, absorption is seen either to be limited to the greenish yellow part of the spectrum or to spread thence towards the blue and to a much less extent towards the red. Thus the various prismatic rays produce a photochemical effect on the visual purple in proportion as they are absorbed by it. Under the action of light the visual purple, whether in solution, or in its natural condition in the rods, passes through what Kühne calls a chamois colour (*i.e.* the purplish orange seen on the chamois) to a yellow, and finally becomes colourless; and Kühne believes that he is justified in speaking of a visual yellow and visual white as products of the photochemical changes undergone by the visual purple.

For the restoration of the visual purple, after it has been destroyed by light, the maintenance of the circulation of the blood through the tissues of the eye is not essential. The choroidal epithelium has by itself, provided that it still retains its tissue life, the power of regenerating the purple.

¹ *Zur Photochemie der Netzhaut. Ueber den Sehpurpur, Verhandl. d. Naturhistorisch-med. Vereins in Heidelberg*, Bd. 1. 1877. *Sehen ohne Purpur. Untersuch. Physiol. Instit. Heidelberg*, Bd. 1. 1877. Ewald and Kühne, *Ueber den Sehpurpur*, *ibid.*

If a portion of the retina of an excised eye be raised from its epithelial bed, bleached, and then carefully restored to its natural position, the purple will return if the eye be kept in the dark. The choroidal epithelium may in fact be spoken of as a 'purpurogenous' membrane.

If an excised eye, a portion of the retina of which has been bleached by light, be treated with a 4 p.c. solution of potash alum before the choroidal epithelium has had time to obliterate the bleaching effects, the retina may remain permanently in that condition, the photochemical effect may, as the photographers say, be fixed. In this way Kühne succeeded in obtaining promising 'optograms'.

The above facts leave no room for doubt that the visual purple is in some way concerned in vision, but it is impossible at present to say what is its exact function. Its conspicuous absence from the cones, and especially its absence from the fovea centralis of man, shew that vision, indeed the best and most exact vision, may take place without it; and Kühne has satisfied himself that frogs whose retinas have been wholly and thoroughly bleached by exposure to light can see perfectly well. It is very tempting to connect the purple in some way with colour vision, but we know that our colour vision is most exact in the fovea centralis, and the frogs just spoken of seemed to be as susceptible to colour as normal frogs.

Simple Sensations.

Relations of the Sensation to the Stimulus. If we put aside for the present all questions of colour, we may say that light, viewed as a stimulus affecting the retina, varies in intensity, that is, in the energy of the luminous vibrations as manifested by their amplitude, and in duration, that is, in the length of time the waves continue to fall upon the retina. The effect of the light will also depend on the extent of retinal surface exposed to the luminous vibrations at the same time. Taking a luminous point, in order to eliminate the latter circumstance, we may make the following statements.

The sensation has a duration much greater than that of the stimulus, and in this respect is comparable to a muscular contraction caused by such a stimulus as a single induction shock. The sensation of a flash of light lasts for a much longer time than that during which luminous vibrations are falling on the retina. Hence when two stimuli, such as two flashes of light, follow each other at a sufficiently short interval, the two sensations are fused into one; and a luminous point moving rapidly round in a circle gives rise to the sensation of a continuous circle of light. This again is quite comparable to muscular tetanus. The interval at which fusion takes place, that is the interval between successive stimuli which must be exceeded in order that successive distinct sensations may be produced, varies according to the intensity of the light, being shorter with the stronger light; with a faint light it is about $\frac{1}{10}$ sec., with a strong light $\frac{3}{30}$ or $\frac{1}{50}$ sec. This may be shewn by rotating rapidly before the eye a disc arranged with alternate black and white sectors of equal width. With a faint illumination, the flickering indicative

of the successive sensations from the white sectors not being completely fused, ceases when the rotation becomes so rapid that each pair of black and white sectors takes only $\frac{1}{10}$ sec. in passing before the eye. When a brighter illumination is used the rapidity must be increased before the flickering disappears. That part of the sensation which is recognized as lasting after the cessation of the stimulus is frequently spoken of as the 'after-image.'

Though the sensation is longer with the stronger light (that from looking at the sun lasting for some time) the commencement of the decline begins relatively earlier, hence the greater difficulty in the complete fusion of successive sensations with the brighter light. The interval at which fusion takes place differs with different colours, being shortest with yellow, intermediate with red, and longest with blue.

The duration of a stimulus necessary to call forth a sensation is exceedingly short, that is to say, the number of vibrations which must fall on the retina in order to affect consciousness may be exceedingly small. Thus the shortest possible flash, such as that of an electric spark, gives rise to a sensation of light.

Objects in motion when illuminated by a single electric spark appear motionless, the stimulus of the light reflected from them ceasing before they can make an appreciable change in their position. When a moving body is illuminated by several rapid flashes in succession, several distinct images corresponding to the positions of the body during the several flashes are generated; the images of the body corresponding to the several flashes fall on different parts of the retina.

The intensity of the sensation varies with the luminous intensity of the object; a wax candle appears brighter than a rushlight. The ratio, however, of the sensation to the stimulus is not a simple one. If the luminosity of an object be gradually increased from a very feeble stage to a very bright one, it will be found that the corresponding sensations, though they likewise gradually increase, increase less and less slowly than the luminosity; and at last an increase of the luminosity produces no appreciable increase of sensation. A light when it reaches a certain brightness, appears so bright that we cannot tell when it becomes any brighter. Hence it is much easier to distinguish a slight difference of brightness between two feeble lights than the same difference between two bright lights; we can easily tell the difference between a rushlight and a wax candle; but two suns, one of which differed from the other merely by just the number of luminous rays which a wax candle emits in addition to those sent forth by a rushlight, would appear to us to have exactly the same brightness. In a darkened room an object placed before a candle will throw what we consider a deep shadow on a sheet of paper, or any white surface. If, however, the sunlight be allowed to fall on the paper at the same time from the opposite side, the shadow is no longer visible. The difference between the total light reflected from that part of the paper where the shadow was, and

which is illuminated by the sun alone, and that reflected from the rest of the paper which is illuminated by the candle as well as by the sun, remains the same; yet we can no longer appreciate that difference.

On the other hand, if we throw two shadows on a white surface with two rushlights and move one rushlight away until the shadow caused by it ceases to be visible; and, having noted the distance to which it had to be moved, repeat the same experiment with two wax candles; we shall find that the wax candle has to be moved just as far as the rushlight. In fact, it is found by careful observation, that within tolerably wide limits, the smallest difference of visual sensation which we can appreciate is a constant fraction (about $\frac{1}{1000}$ th) of the total luminosity of the light employed. The same law holds good with regard to the other senses as well. The smallest difference in length we can detect between two lines, one an inch long and the other a little less than an inch, is the same fraction of an inch, that the smallest difference in length we can detect between a line a foot long and one a little less than a foot, is of a foot. Put in a more general form then, the law, which is often called Weber's law, is as follows: When a stimulus is continually increased, the smallest increase of sensation which we can appreciate remains the same if the proportion of the increase of stimulus to the whole stimulus remains the same; that is to say, the one varies directly as the other. Fechner, regarding sensation as the summation of a series of increments of sensation corresponding to increments of stimulus, and making use of the mathematical operation of integration, transformed the above statement into the expression that "sensation varies, not as the stimulus, but as the logarithm of the stimulus." This expression is frequently spoken of as Fechner's formula, or Fechner's law. It must be remembered, however, that Weber's law, on which Fechner's formula is based, is true within certain limits only. The latter indeed must be considered rather as a useful and convenient than as an exact expression¹.

Distinction and Fusion of Sensations. When light falls on a large portion of the retina the total sensation produced is greater in amount than when a small portion only of the retina is affected; a large piece of white paper produces a greater total effect on our

¹ Weber's law may be stated mathematically as $\Delta S = K \frac{\Delta x}{x}$, where ΔS is the smallest appreciable increment of sensation caused by Δx , the corresponding increment of the stimulus x , and K is a constant.

If this be integrated we get

$$S = K \log x + c.$$

If x be diminished there will be a certain value of x at which all sensation ceases; if this be x' , then

$$0 = K \log x' + c,$$

or

$$c = -K \log x',$$

whence

$$S = K \log x - K \log x'.$$

$$S = K \log \frac{x}{x'},$$

which is Fechner's more complete formula.

consciousness than a small one, though, if the surfaces be uniformly and equally illuminated, the *intensity* of the sensation is in each case the same; the small piece of paper appears as bright or as 'white' as the large one. If the images of two luminous objects fall on the retina at sufficient distances apart, the consequent sensations are distinct, and the intensity of each sensation will depend solely upon the luminosity of the corresponding object. If however the two objects are made to approach each other, a point will be reached at which the two sensations are fused into one. When this occurs the intensity of the total sensation produced will be greater than that of either of the sensations caused by the single objects. A number of luminous points scattered over a wide surface would appear each to have a certain brightness; each would give rise to a sensation of a certain intensity. If they were all gathered into one spot, that spot would appear far brighter than any of the previous points; the intensity of the sensation would be greater. We may therefore suppose the retina to be divided into areas corresponding to sensational units. If the images from two luminous objects fall on separate visual areas, if we may so call them, two distinct sensations will be produced; if, on the contrary, they both fall on the same visual area, one sensation only will be produced. Where the sensations are separate, the intensity of the one (with exceptions hereafter to be mentioned) is not affected by the presence of the other; but where they become fused the intensity of the united sensations is greater than either of, though not equal to the sum of, the single sensations. The existence of these sensational units is the basis of distinct vision. When we speak of the smallest size visible or distinguishable, we are referring to the dimensions of the retinal areas corresponding to these sensational units. The retinal area must be carefully distinguished from the sensational unit, for the sensation is, as we have seen, a process whose arena stretches from the retina to certain parts of the brain, and the circumscription of the sensational unit, though it must begin as a retinal area, must also be continued as a cerebral area in the brain, the latter corresponding to, and being as it were the projection of, the former. With most people two stars appear as a single star when the distance between them subtends an angle of less than 60 seconds; and Weber found that the best eyes failed to distinguish two parallel white streaks whose median lines were at a distance less than that subtending an angle of 73 seconds. Hirschmann¹ could distinguish objects 50 seconds distant from each other. An angle of 73 seconds in an object corresponds in the diagrammatic eye (see p. 398) to the length of $5\cdot26 \mu^2$ in the retinal image, and one of 50 seconds to $3\cdot65 \mu$.

Max Schultze² counted 50 cones along a line of 200μ in length drawn through the centre of the yellow spot; this would give 4μ for

¹ Quoted by Helmholtz, *Phys. Optik.* p. 841.

² By μ is meant one-thousandth of a millimetre.

³ Stricker, *Handbuch*, p. 1023.

the distance between the centres of two adjoining cones in the yellow spot, the average diameter of a cone at its widest part being 3μ and there being slight intervals between neighbouring cones. Hence if we take the centre of a cone as the centre of an anatomical retinal area, these anatomical areas correspond very fairly to the physiological visual areas as determined above.

That is to say, if two points of the retinal image are less than 4μ apart, they may both lie within the area of a single cone; and it is just when they are less than about 4μ apart that they cease to give rise to two distinct sensations. It must be remembered, however, that the fusion or distinction of the sensations is ultimately determined by the brain and not by the retina. Two points of the retinal image less than 4μ apart might lie both within the area of a single cone; but the reason why, under such circumstances, they give rise to one sensation only is not because one cone-fibre only is stimulated. Two points of a retinal image might lie, one on the area of one cone and another on the area of an adjoining cone, and still be less than 4μ apart; in such a case two cone-fibres would be stimulated, and yet only one sensation would be produced. So also in the less sensitive peripheral parts of the retina two points of the retinal image might stimulate two cones a considerable distance apart, and yet give rise to one sensation only.

In the case where the two points lie entirely within the area of a single cone, it is exceedingly probable that, even if the adjacent cones or cone-fibres in the retina are not at the same time stimulated, impulses radiate from the cerebral ending of the excited cone into the neighbouring cerebral endings of the neighbouring cones; in other words, the sensation-area in the brain does not exactly correspond to and is not sharply defined like the retinal area, but gradually fades away into neighbouring sensation-areas. We may imagine two points of the retinal image so far apart that even the extreme margins of their respective cerebral sensation-areas do not touch each other in the least; in such a case there can be no doubt about the two points giving rise to two sensations. We might, however, imagine a second case where two points were just so far apart that their respective sensation-areas should coalesce at their margins, and yet that in passing from the centre of one sensation-area to the centre of the other, we should find on examination a considerable fall of sensation at the junction of the two areas; and in a third case we might imagine the two centres to be so close to each other that in passing from one to the other no appreciable diminution of sensation could be discovered. In the last case there would be but one sensation, in the second there might still be two sensations if the marginal fall were great enough, even though the areas partially coalesced. Thus, though the mosaic of rods and cones is the basis of distinct vision, the distinction or fusion of two visual impulses is ultimately determined by the disposition and condition of the cerebral centres. Hence the possibility of increasing by exercise the faculty of distinguishing two sensations. This however is even more strikingly shewn in touch than in sight.

Colour Sensations.

When we allow sunlight reflected from a cloud or sheet of paper to fall into the eye, we have a sensation which we call a

sensation of white light. When we look at the same light through a prism, and allow different parts of the spectrum to fall in succession into the eye, we have sensations which we call respectively sensations of red, yellow, green and blue light. In other words, rays of light falling on the retina give rise to different sensations, according to the wave-lengths of the rays. Though we speak of the spectrum as consisting of a few colours—red, green, &c., there are an almost infinite number of intermediate tints in the spectrum itself; and we perceive in external nature a large number of colours, such as purple, brown, grey, &c., which do not correspond to any of the colour sensations gained by regarding the successive parts of the spectrum. We find however, on examination, that many apparently distinct colour sensations may be obtained by the fusion of two or more other colour sensations. Thus purple, which is not present in the spectrum, may be at once produced by fusing the sensations of blue and red in proper proportions; and the various tints and shades of nature may be imitated by fusing a particular colour sensation with the sensation of white, or by allowing a certain quantity of light of a particular colour to fall sparsely over the area of the retina, which is at the same time protected from the access of any other light, *i. e.* as we say, by mixing the colour with black. Thus the browns of nature result from various admixtures of yellow, red, white and black; and a small quantity of white light, scattered over a large area of the retina, *i. e.* white largely mixed with black, forms a grey. In fact, the qualities of a colour depend (1) on the nature of the prismatic colour or colours falling on a given area of the retina, *i. e.* on the wave-lengths of the constituent rays; (2) on the amount of this coloured light which falls on the area of the retina in a given time; and (3) on the amount of white light falling on the same area at the same time. When rays corresponding to a prismatic colour fall upon the retina unaccompanied by any white light, the colour is said to be 'saturated'; and a colour is spoken of as more or less saturated according as it is mixed with less or more white light. We are guided by the first of the above conditions when we describe a colour as being of such a tint or hue. But we have no common phrases by which we distinguish the second of the above conditions from the third. The word 'pale,' it is true, is most frequently used to express a colour very slightly saturated; but the words 'rich' or 'deep' are used sometimes as meaning highly saturated, sometimes as meaning simply that a large quantity of light of the particular hue is passing into the eye. So also with the phrase 'bright'; this we often use when a large amount of coloured and white light fall at the same time on the same retinal area, but we sometimes also use it to express the mere intensity of the sensation independent of the amount of saturation.

The best method of fusing colour sensations is that adopted by Maxwell, of allowing two different parts of the spectrum to fall on the same part

of the retina at the same time. The use of the pure prismatic colours eliminates errors which arise when pigments, the colours of which are not pure, but mixed, are employed. And where pigments are used it is the sensations which must be mixed and not the pigments themselves. Thus while the sensations of yellow and indigo when fused give rise to a sensation of white, yellow and indigo pigments when mixed appear green on account of their reciprocally absorbing part of each other's colour; the indigo particles absorb the red of the yellow, and the yellow particles absorb the blue of the indigo, so that only green is left for both to reflect. When pure pigments, *i. e.* pigments corresponding as closely as possible to the prismatic colours, are used, satisfactory results may be gained, either by using the reflection of the image of one pigment so that it falls on the retina at the same spot as the direct image of the other, or by allowing the image of one pigment to fall on the retina before the sensation produced by the other has passed away. The first result is easily reached by Helmholtz's simple method of placing two pieces of coloured paper a little distance apart on a table, one on each side of a glass plate inclined at an angle. By looking down with one eye on the glass plate the reflected image of the one paper may be made to coincide with the direct image of the other, the angle which the glass plate makes with the table being adjusted to the distance between the pieces of paper. In the second method, the 'colour top' is used; sectors of the colours to be investigated are placed on a disc made to rotate very rapidly, and the image of one colour is thus brought to bear on the retina so soon after the image of another, that the two sensations are fused into one.

When the sensations corresponding to the several prismatic colours are fused together in various combinations, the following remarkable results are brought about.

1. When red and yellow in certain proportions are mixed together the result is a sensation of orange, quite indistinguishable from the orange of the spectrum itself. Now the latter is produced by rays of certain wave-length, whereas the rays of red and of yellow are respectively of quite a different wave-length. The *orange of the spectrum* cannot be made up by any mixture of the *red and the yellow of the spectrum* in the sense that the red and yellow rays can unite together to form rays of the same wave-length as the orange rays; the three things are absolutely different. It is simply the mixed *sensation* of the red and yellow which is so like the *sensation* of orange; the mixture is entirely and absolutely a physiological one. And since we must suppose that rays of different wave-length give rise to different sensory impulses, and that the sensory impulses generated by orange rays are different from those generated by red and by yellow rays, we are led to infer either that the sensory impulses which rays of a given wave-length originate are themselves of a mixed character, or that the mixture takes place at the time when the sensory impulses are becoming converted into sensations. The first of these views is the one generally adopted.

2. When certain colours are mixed together in pairs in certain definite proportions, the result is white. These colours are

Red (near *a*)¹, and Blue-Green (near F),
 Orange (near C), and Blue (between F and G),
 Yellow (near D), and Indigo-Blue (near G),
 Green-Yellow (near E), and Violet (between G and H),

and are said to be 'complementary' to each other. To these might be added the peculiar non-prismatic colour purple, which with green also gives white.

3. If we select arbitrarily any three distinct colours, *i.e.* any three parts of the spectrum sufficiently far apart, say red, green, and blue, we can, by a proper adjustment of the proportions of each, produce white. Further, by a proper addition of white, these three colours can be taken in such proportions as to produce the sensations of all other colours. That is to say, given three standard sensations, all the other sensations may be gained by the proper mixture of these.

If we suppose that the visual apparatus is so constructed that we possess three standard sensations, and that rays of different wave-length produce all three of these sensations to a different extent according to their wave-length, we can easily regard the whole of our sensations of colour as compounds of three 'primary colour sensations.' We might thus represent our colour sensations by such a diagram as that given in Fig. 46, where one primary sensation is seen to be pro-

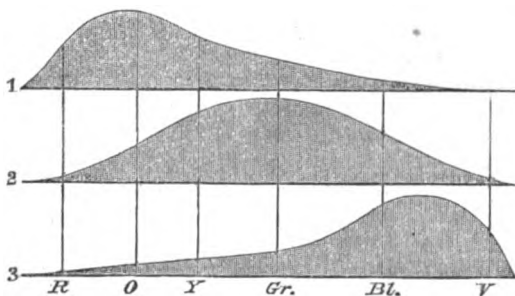

FIG. 46. DIAGRAM OF THREE PRIMARY COLOUR SENSATIONS.

1 is the so-called 'red,' 2 'green,' and 3 'violet' primary colour sensation. R, O, Y, &c. represent the red, orange, yellow, &c., colour of the spectrum, and the diagram shews, by the height of the curve in each case, to what extent the several primary colour sensations are respectively excited by vibrations of different wave-lengths.

duced in greatest intensity by the rays at the red end of the spectrum, the second by those near the middle, and the third by those at the violet end of the spectrum. Under this view orange rays are those which produce much of the first sensation, less of the second, and hardly any of the third; whereas blue rays produce much of the third, less of the second, and hardly any of the first; and so on.

¹ These letters refer to Fraunhofer's lines.

This theory of three primary colour sensations we owe to Young; but since its general acceptance has been largely due to the labours of Helmholtz, it is frequently spoken of as the Young-Helmholtz theory. Young's view took the form of the hypothesis that there were present in the retina three sets of fibres, each set corresponding to a primary colour sensation, and being sensitive in a different degree to the various rays of light. In the retina itself no such distinction of fibres can be found. We are entirely in the dark concerning the anatomical basis not only of colour sensations but also of vision as a whole. We have reason to think, as we shall presently shew, that visual impulses are started in that part of the retina which lies beyond the retinal blood-vessels; but in the generation of those impulses we can assign no exact functions to rods or cones, to rod fibres or cone fibres, or to the various bodies constituting the external nuclear layer. The view that the cones rather than the rods of the retina are concerned in colour vision cannot be regarded as established. The argument that cones are absent from the retinas of nocturnal animals, remains invalid until it has been proved that these animals are colour-blind; and the argument that in the fovea centralis cones only exist, may be used equally well to prove that the rods are of no use in vision at all. In the eyes of Birds, Reptiles and Amphibia, coloured globules (red or yellow) are found in the cones at the junction of the inner and outer limbs. It has been suggested that these are connected with colour vision, the cones with red globules, for instance, allowing red light only to pass through the inner limb and impinge on the outer limb, so that these cones would serve as organs for seeing red. But this is very doubtful.

The Young-Helmholtz theory has not been accepted by all inquirers. Its most serious opponent at the present time is Hering¹, who, following Aubert², and indeed Leonardo Da Vinci, maintains that the primary visual sensations are white, black, red, yellow, green, and blue. He considers that these several sensations arise as the results of changes in what may be called the visual substance of the visual nervous apparatus, those changes which give rise to black, green, and blue being essentially processes of assimilation or construction of the visual substance, while those which give rise to white, red, and yellow are processes of dissimulation, or destruction of the visual substance. Black and white, green and red, blue and yellow, form accordingly antagonistic rather than complementary pairs, and the visual organ is conceived of as never existing during life, in a state of complete rest. A satisfactory discussion of the relative merits of this and of the generally accepted view, would lead us beyond the proper limits of this work, but Hering uses his view with great ability to explain the obscure phenomena of 'contrasts' (see p. 433) and 'negative images' (p. 426).

Admitting, however, that the hypothesis of three primary colour sensations explains many of the phenomena of colour vision, there still remains the question, 'What are the three primary colour sensations?' We have spoken of any three arbitrarily selected colour sensations producing by manipulation all the other colour sensations; but, of what kind are the three sensations which may be considered

¹ *Zur Lehre vom Lichtsinne.* Wien. *Sitzungsbericht.* LXVI. (1872) LXVIII. LXIX. LXX.

² *Physiologie der Netzhaut.* 1865.

as the actual primary sensations? We cannot enter here into the discussion of this question; and may simply state that the most generally accepted view is, that the three primary sensations correspond to what we call red, green, and violet; and in the diagram, Fig. 46, the upper figure represents this primary red sensation, the middle figure green, and the lower violet.

Colour Blindness. All persons vary much in their power of discriminating and appreciating colour, *i.e.* in the intensity and accuracy of their colour sensations; but some people regard as similar, colours which to most people are glaringly distinct, and these persons are said to be 'colour blind.' The most common form of colour blindness is that of persons unable to distinguish green and red from each other. As in the case of Dalton, they tell a red gown lying on a green grass plot, or a red cherry among the green leaves, by its form, and not by its colour. They confound not only red, brown, and green, but also rose, purple, and blue. They cannot see the red end of the spectrum, all this part appearing to them dark. Their vision is best explained by supposing that they lack altogether the primary sensation of red.

Hence they probably see in the spectrum only two colours, blue and green, with various tints; our red, orange, yellow and green appearing green, and all the rest blue, green-blue being to them a kind of grey. Since the sensation of green seems to be *absolutely* most intense in that part of the spectrum which we call yellow, though of course relatively to the other two primary sensations most intense in the green, our yellow probably corresponds in them to the sensation of a bright deep green. All the colours they see can, in fact, be produced by mixtures of yellow and blue.

Cases in which the other primary sensations may be supposed to be absent, *i.e.* green blindness and violet blindness, are much more rare, and have not as yet been examined with sufficient completeness.

Influence of the pigment of the yellow spot. In the macula lutea, which part of the retina we use chiefly for vision, images falling on other parts of the retina being said to give rise to 'indirect vision,' the yellow pigment absorbs some of the greenish-blue rays. Hence all that which we are in the habit of calling *white* is in reality more or less yellow. We may use this feature of the yellow spot for the purpose of making the spot, so to speak, visible to ourselves, by an experiment suggested by Maxwell. A solution of chrome alum, which only transmits red and greenish-blue rays, is held up between the eye and a white cloud. The greenish-blue rays are absorbed by the yellow spot, and here the light gives rise to a sensation of red; whereas in the rest of the field of vision, the sensation is that ordinarily produced by the purplish solution. The yellow spot is consequently marked out as a rosy patch. This very soon however dies away.

In speaking of sensation as a function of the stimulus, p. 417, we referred to white light only; but the different colours are unequal in the relations borne by the intensity of the stimulus to the amount of sensation produced. Thus the more refrangible blue rays produce a sensation more readily than the yellow or red rays. Hence in dim lights, as those of

evening and moonlight, the blues preponderate, and the reds and yellows are less obvious. So also when a landscape is viewed through a yellow glass, the yellow hue suggests to the mind bright sunlight and summer weather, although the actual illumination which reaches the eye is diminished by the glass. Conversely when the same landscape is viewed through a blue glass the idea of moonlight or winter is suggested.

The theory of primary colour sensations may be used to explain why any coloured light, if made sufficiently intense, appears white. Thus a violet light of moderate intensity appears violet because it excites the primary sensation of violet much more than those of green and red. If the stimulus be increased the maximum of violet stimulation will be reached, while the stimulation of green will continue to be increased and even that of red to a slight degree. The result will be that the light appears violet mixed with green, that is blue. If the stimulus be still further increased while the green and violet are both excited to the maximum, the red stimulation may be increased until the result is violet, green, and red in the proportions which make white light. And so with light of other colours.

After-Images. We have already seen that in vision the sensation lasts much longer than the stimulus. Under certain circumstances, such as condition of the eye, intensity of the stimulus, &c., the sensation is so prolonged, that it is spoken of as an after-image. Thus, if the eye be directed to the sun, the image of that body is present for a long while after; and if, on early waking, the eye be directed to the window for an instant and then closed, an image of the window with its bright panes and darker sashes, the various parts being of the same colour as the object, will remain for an appreciable time. These images, which are simply continuations of the sensation, are spoken of as *positive after-images*. They are best seen after a momentary exposure of the eye to the stimulus.

When, however, the eye has been for some time subject to a stimulus, the sensation which follows the withdrawal of the stimulus is of a different kind; what is called a *negative after-image*, or *negative image*, is produced. If, after looking stedfastly at a white patch on a black ground, the eye be turned to a white ground, a grey patch is seen for some little time. A black patch on a white ground similarly gives rise on a grey ground to a negative image of a white patch. This may be explained as the result of exhaustion. When the white patch has been looked at steadily for some time, that part of the retina on which the image of the patch fell becomes tired; hence the white light coming from the white ground subsequently looked at, which falls on this part of the retina, does not produce so much sensation as in other parts of the retina; and the image, consequently, appears grey. And so in the other instance, the whole of the retina is tired, except at the patch; here the retina is for a while most sensitive, and hence the white negative image.

When a red patch is looked at, the negative image is a green blue, that is, the colour of the negative image is complementary to that

of the object. Thus also orange produces a blue, green a pink, yellow an indigo-blue, negative image; and so on. This too can be explained as a result of exhaustion. When the coloured patch is looked at, one of the primary colour sensations is much exhausted, and the other two less so, in varying proportions, according to the exact nature of the colour of the patch; and the less exhausted sensations become prominent in the after-image. Thus, the red patch exhausts the red sensation, and the negative image is made up chiefly of green and blue sensations, that is, appears to be greenish blue, or bluish green, according to the tint of the red. Similarly, when the eye, after looking at a coloured patch, is turned to a coloured ground, the effects may easily be explained by reference to the comparative exhaustion of the colour sensations excited by the patch and the ground respectively; if a yellow (*i. e.* a green and red) ground be chosen after looking at a green object, the negative image will appear of a reddish yellow, and so on.

What is not so clear is why negative images should make their appearance without any subsequent stimulation of the retina. When the eyes are shut and all access of light, even through the eyelids, carefully avoided, the field of vision is not absolutely dark; there is still a sensation of light, the so-called 'proper light' of the retina. If a white patch on a black ground be looked at for some time, and the eyes then shut, a negative (black) image of the spot will be seen on the ground of the 'proper light' of the retina, having in its immediate neighbourhood a specially bright corona. So also, if a window be looked at and the eyes then closed, the positive after-image with bright panes and dark sashes gives rise to a negative after-image with bright sashes and dark panes; and similar effects appear with colours. Plateau¹ has attempted to explain the various phenomena of after-images by supposing oscillations to take place in some part of the visual apparatus; but the matter is surrounded with difficulties².

SEC. 3. VISUAL PERCEPTIONS.

Hitherto we have studied sensations only, and have considered an external object, such as a tree, as simply a source of so many distinct sensations, differing from each other in intensity and kind (colour). In the mind these sensations are coordinated into a perception. We are not only conscious of a number of sensations of bright and dim lights, of green, brown, black, &c., but these sensations are so arranged, by virtue of cerebral processes, that we 'see a tree.' There is, as is often said, a mental image in the brain corresponding to the physical image on the retina.

When we look upon the external world, a variety of images are formed at the same time on the retina, and give rise to a number of contemporaneous visual sensations. The sum of these sensations

¹ *Théorie gén. des Apparences visuelles.* Bruxelles, 1834.

² Cf. Hering, *op. cit.*

constitutes 'the field of vision,' which varies of course with every movement of the eye. This field of vision, being in reality an aggregate of sensations, is of course a *subjective* matter; but we are in the habit of using the same phrase to denote the sum of external objects which give rise to the aggregate of sensations; in common language the field of vision is 'all that we can see' in any position of the eye, and we have a field of vision for each eye separately and for the two eyes combined.

Using for the present the words in their subjective sense, we may remark, that we are able to assign to each constituent sensation its place among the aggregate of sensations constituting the field of vision; we can, as we say, *localise* the sensation. We can say whether it belongs to (what we regard as) the right-hand or left-hand, the upper or the lower part, of the field of vision. We are able to distinguish the relative positions of any two distinct sensations; and the relative positions, together with the relative intensities and qualities (colour) of the sensations arising from any object determine our perception of the object. It need hardly be remarked that this localisation is purely subjective. We simply determine the position of the *sensation* in the field of vision (which is itself a wholly subjective matter); we do not determine the position of the *object*. The connection between the position of the object in the external world and the position of the sensation in the field of vision, cannot be determined by visual observation alone. All the information which can be gained by the eye is limited to the field of vision, and provided that the relative position of the sensations in the field of vision remained the same, the actual position of external objects might, as far as vision is concerned, be changed without our being aware of it.

As a matter of fact the field of vision in one important particular does not correspond to the field of external objects. The image on the retina is inverted; the rays of light proceeding from an object which by touch we know to be on what we call our right hand, fall on the left-hand side of the retina. If therefore the field of vision corresponded to the retinal image, the object would be seen on the left hand. We however see it on the right hand, because we invariably associate right-hand tactile localisation with left-hand visual localisation; that is to say, our field of vision, when interpreted by touch, is a re-inversion of the retinal image.

The dimensions of the field of vision of a single eye are about 145° for the horizontal and 100° for the vertical meridian, the former being distinctly greater than the latter. The horizontal dimension of the field of vision for the two eyes is about 180° . By movements of the eyes, however, apart from those of the head, the extent may be increased to 260° in the horizontal and 200° in the vertical direction.

The satisfactory perception of external objects requires distinct vision; and of this, as we have already said, the formation of a dis-

tinct image on the retina is an essential condition. We can receive visual sensations of all kinds with the most imperfect dioptric apparatus, but our perception of an object is precise in proportion to the clearness of the image on the retina.

Region of Distinct Vision. If we take two points, such as two black dots, only just so far apart that they can be seen distinctly as two when placed near the axis of vision, and then, keeping the axis fixed, move the two points out into the circumferential parts of the field of vision, it will be found that the two soon appear as one. The two sensations become fused, as they would do if brought nearer to each other in the centre of the field. The farther away from the centre of the field, the farther apart must two points be in order that they may be seen as two. In other words, vision is much more distinct in the centre of the field than towards the circumference. Practically the region of distinct vision may be said to be limited to the macula lutea, or even to the fovea centralis; by continual movements of the eye we are constantly bringing any object which we wish to see in such a position that its image falls on this region of the retina.

The diminution of distinctness does not diminish equally from the centre to the circumference along all meridians. The outline described by a line uniting the points where two spots cease to be seen as two when moved along different radii from the centre, is a very irregular figure.

The sensations of colour are much more distinct in the centre of the retina, than towards the circumference. If the visual axis be fixed and a piece of coloured paper be moved towards the outside of the field of vision, the colour undergoes changes and is eventually lost, red disappearing first, then green, and blue last. A purple colour becomes blue, and a rose colour a bluish white. In fact, there seems to be a certain amount of red-blindness in the peripheral parts of all retinas.

Blind Spot. There is one part of the retina on which rays of light falling give rise to no sensations; this is the entrance of the optic nerve, and the corresponding area in the field of vision is called the blind spot. If the visual axis of one eye, the right for instance, the other being closed, be fixed on a black spot in a white sheet of paper, and a small black object, such as the point of a quill pen dipped in ink, be moved gradually sideways over the paper away to the outside of the field of vision, at a certain distance the black point of the quill will disappear from view. On continuing the movement still farther outward the point will again come into view and continue in sight until it is lost in the periphery of the field of vision. If the pen be used to make a mark on the paper at the moment when it is lost to view, and at the moment when it comes into sight again; and if similar marks be made along the other meridians as well as the horizontal, an irregular outline will be drawn circumscribing an area of the field of vision within which rays of light

produce no visual sensation. This is the blind spot. The dimensions of the figure drawn vary of course with the distance of the paper from the eye. If this distance be known, the size as well as the position of the area of the retina corresponding to the blind spot may be calculated from the diagrammatic eye (p. 398). The position exactly coincides with the entrance of the optic nerve, and the dimensions (about 1.5 mm. diameter) also correspond. While drawing the outline as above directed the indications of the large branches of the retinal vessels as they diverge from the entrance of the nerve can frequently be recognized. The existence of the blind spot is also shewn by the fact that an image of light, sufficiently small, thrown upon the optic nerve by means of the ophthalmoscope, gives rise to no sensations.

The existence of the blind spot proves that the optic fibres themselves are insensible to light; it is only through the agency of the retinal expansion that they can be stimulated by luminous vibrations.

Purkinje's Figures. If one enters a dark room with a candle, and while looking at a plain (not parti-coloured) wall, moves the candle up and down, holding it on a level with the eyes by the side of the head, there will appear in the field of vision of the eye of the same side, projected on the wall, an image of the retinal vessels, quite similar to that seen on looking into an eye with the ophthalmoscope. The field of vision is illuminated with a glare, and on this the branched retinal vessels appear as shadows. In this mode of experimenting the light enters the eye through the cornea, and the candle forms on the nasal side of the retina an image, and it is the light emanating from this which throws shadows of the retinal vessels on to the rest of the retina. A far better method is for a second person to concentrate the rays of light, with a lens of low power, on to the outside of the sclerotic just behind the cornea; the light in this case emanates from the illuminated spot on the sclerotic and passing straight through the vitreous humour throws a direct shadow of the vessels on to the retina. Thus the rays passing through the sclerotic at b , Fig. 47, in the direction $b\nu$, will throw a shadow of the vessel ν on to the retina at β ; this will appear as a dark line at B in the glare of the field of vision. This proves that the structures in which sensory visual impulses originate must lie behind the retinal vessels, otherwise the shadows of these could not be perceived.

If the light be moved from b to a , the shadow on the retina will move from β to α , and the dark line in the field of vision will move from B to A. If the distance BA be measured when the whole image is projected at a known distance, kB from the eye, k being the optical centre¹, then,

¹ For the properties of the optical centre, we must refer the reader to the various treatises on optics. The optical centre of a lens is the point through which all the principal rays, of the various pencils of rays falling on the lens, pass. The diagrammatic eye of Listing (p. 398) has two optical centres, but these may, without serious error, be further reduced for practical purposes to one lying in the lens near its posterior surface, at about 15 mm. distance from the retina.

knowing the distance $k\beta$ in the diagrammatic eye, the distance βa can be calculated. But if the distance βa be thus estimated, and the distance ba be directly measured, the distances βv , av , bv , av can be calculated, and if the appearance in the field of vision is really caused by the shadow of v falling on β , these distances ought to correspond to the distances of the retinal vessels v from the sclerotic b on the one hand, and from that part of the retina β where visual impressions begin, on the other. H. Müller found that the distance βv thus calculated corresponded to the distance of

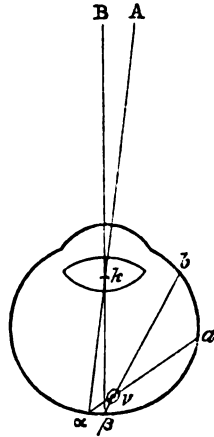

FIG. 47. DIAGRAM ILLUSTRATING THE FORMATION OF PURKINJE'S FIGURES WHEN THE ILLUMINATION IS DIRECTED THROUGH THE SCLEROTIC.

the retinal vessels from the layer of rods and cones. Thus Purkinje's figures prove in the first place that the sensory impulses which form the commencement of visual sensations originate in some part of the retina behind the retinal vessels, *i.e.* somewhere between them and the choroid coat; and H. Müller's calculations go far to shew that they originate at the most posterior or external part of the retina, *viz.* the layer of rods and cones. It must be admitted however that H. Müller's results were not sufficiently exact to allow any great stress to be placed on this argument.

It is desirable in these cases to move the light to and fro, especially in the first method, as the retina soon becomes tired, and the image fades away. Some observers can recognize in the axis of vision, a faint shadow corresponding to the edge of the depression of the fovea centralis.

In the second method of experimenting, the image always moves in the same direction as the light, as it obviously must do. In the first method, where the light enters through the cornea, the image moves in the same direction as the light when the light is moved from right to left, provided the movement does not extend beyond the middle of the cornea, but in the opposite direction to the light when the latter is moved up and down. In Fig. 48, which represents a horizontal section of an eye, if a be moved to

a , b will move to β , the shadow on the retina c to γ , and the image d to δ . If on the other hand a be supposed to move above the plane of the paper, b will move below, in consequence c will move above, and d will appear to move below, *i.e.* d will sink as a rises.

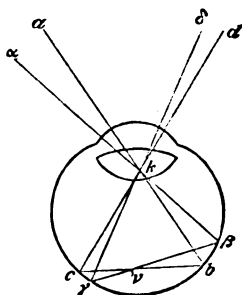

FIG. 48. DIAGRAM ILLUSTRATING THE FORMATION OF PURKINJE'S FIGURES WHEN THE ILLUMINATION IS DIRECTED THROUGH THE CORNEA.

The retinal vessels may also be rendered visible by looking through a small orifice at a bright field such as the sky, and moving the orifice very rapidly from side to side or up and down. If the movement be from side to side, the vessels which run vertical will be seen; if up and down, the horizontal vessels. The fine capillary vessels are seen more easily in this way than by Purkinje's method. The same appearances may also be produced by looking through a microscope from which the objective has been removed and the eye-piece only left (or in which at least there is no object distinctly in focus in the field), and moving the head rapidly from side to side or backwards and forwards. Or the microscope itself may be moved; a circular movement of the field will then bring both the vertical and horizontally directed vessels into view at the same time.

Modified Perceptions.

Since our perception of external objects is based on the distinctness of the constituent sensations which go to form the perception, it might be expected that our conception of external nature would be a faithful transcript of the sensations originating in the retina and transformed in the brain into perceptions, and that therefore the mental condition resulting from our looking at any object or view would correspond exactly to the retinal image. We find, however, that this is not the case. The sensations and probably even the simple sensory impulses produced by an image react upon each other, and these reactions modify our perceptions, independently of the physical conditions of the retinal image. There arise certain discrepancies between the retinal image and the perception, some having their source in the retina, some in the brain, and others being of such a nature, that it is difficult to say where the irrelevancy is introduced.

Irradiation. A white patch on a dark ground appears larger, and a dark patch on a white ground smaller, than it really is. This is especially so when the object is somewhat out of focus, and may, in this case, be partly explained by the diffusion circles which, in each case, encroach from the white upon the dark. But over and beyond this, any sensation, coming from a given retinal area, occupies a larger share of the field of vision, when the rest of the retina and central visual apparatus are at rest, than when they are simultaneously excited. It is as if the neighbouring, either retinal or cerebral, structures were sympathetically thrown into action at the same time.

Contrast. If a white strip be placed between two black strips, the edges of the white strip, near to the black, will appear whiter than its median portion; and if a white cross be placed on a black background, the centre of the cross will appear sometimes so dim, compared with the parts close to the black, as to seem shaded. This occurs even when the object is well in focus; the increased sensation of light which causes the apparent greater whiteness of the borders of the cross is the result of the 'contrast' with the black placed immediately close to it. Still more curious results are seen with coloured objects. If a small piece of grey paper be placed on a sheet of green paper, and both covered with a sheet of thin tissue paper, the grey paper will appear of a pink colour, the complementary of the green. This effect of contrast is far less striking, or even wholly absent, when the small piece of paper is white instead of grey, and generally disappears when the thin covering of tissue paper is removed. It also vanishes if a bold broad black line be drawn round the small piece of paper, so as to isolate it from the ground colour. If a book, or pencil, be placed vertically on a sheet of white paper, and illuminated on one side by the sun, and on the other by a candle, two shadows will be produced, one from the sun which will be illuminated by the yellowish light of the candle, and the other from the candle which will in turn be illuminated by the white light of the sun. The former naturally appears yellow; the latter, however, appears not white but blue; it assumes, by contrast, a colour complementary to that of the candle-light which surrounds it. If the candle be removed, or its light shut off by a screen, the blue tint disappears, but returns when the candle is again allowed to produce its shadow. If, before the candle is brought back, vision be directed through a narrow blackened tube at some part falling entirely within the area of what will be the candle's shadow, the area, which in the absence of the candle appears white, will continue to appear white when the candle is made to cast its shadow, and it is not until the direction of the tube is changed so as to cover part of the ground outside the shadow, as well as part of the shadow, that the latter assumes its blue tint¹.

¹ Cf. Hering, *loc. cit.*

Filling up the Blind Spot. Though, as we have seen, that part of the retina which corresponds to the entrance of the optic nerve is quite insensible to light, we are conscious of no blank in the field of vision. When in looking at a page of print we fix the visual axis so that some of the print must fall on the blind spot, no gap is perceived. We could not expect to see a black patch, because what we call black is the absence of the sensation of light from structures which are sensitive to light; we must have visual organs to see black. But there are no visual organs in the blind spot, and consequently we are *in no way at all* affected by the rays of light which fall on it; the field of vision closes in as if the blind spot did not exist at all.

Ocular Spectra. So far from our perceptions exactly corresponding to the arrangements of the luminous rays which fall on the retina, we may have visual sensations and perceptions in the entire absence of light. Any stimulation of the retina or of the optic nerve sufficiently intense will give rise to a visual sensation. Gradual pressure on the eyeball causes a sensation of rings of coloured light, the so-called phosphenes; a sudden blow on the eye causes a sensation of flashes of light, and the seeming identity of the visual sensations so brought about with visual sensations produced by light is well illustrated by the statement once gravely made in a German court of law, by a witness who asserted that on a pitch dark night he recognised an assailant by help of the flash of light caused by the assailant's hand coming in violent contact with his eye. Electrical stimulation of the eye or optic nerve will also give rise to visual sensations.

The sensations which may arise without any light falling on the retina need not necessarily be undefined; on the contrary they may be most clearly defined. Complex and coherent visual images or perceptions may arise in the brain without any corresponding objective luminous cause. These so-called ocular spectra or phantoms, which are the result of an intrinsic stimulation of some (probably cerebral) part of the visual apparatus, have a distinctness which gives them an apparent objective reality quite as striking as that of ordinary visual perceptions¹. They may occasionally be seen with the eyes open (and therefore while ordinary visual perceptions are being generated) as well as when the eyes are closed. They sometimes become so frequent and obtrusive as to be distressing, and form an important element in some kinds of delirium, such as delirium tremens.

Appreciation of apparent size. By the eye alone we can only estimate the *apparent* size of an object, we can only tell what space it takes in the field of vision, we can only perceive the dimensions of the retinal image, and therefore have a right only to speak of the angle which the diameter of the object subtends. The *real* size of an

¹ I am acquainted with a case in which ocular spectra of a pleasing and gorgeous character, such as visions of flowers, and landscapes, can be brought on at once by compressing the eyeballs with the orbicularis muscle.

object must be determined by other means. But our perception of even the apparent size of an object is so modified by concurrent circumstances that in many cases it cannot be relied on. The apparent size of the moon must be the same to every eye, and yet while some persons will be found ready to compare the moon in mid heavens with a threepenny piece, others will liken it to a cart-wheel; that is to say, the angle subtended by the moon is thought by the one to be equal to that subtended by a threepenny piece viewed at a few feet, and by the other to that subtended by a cart-wheel viewed at a few yards, from the eye. If a line such as AC , Fig. 49, be divided into two equal parts AB, BC , and AB

FIG. 49.

be divided by distinct marks into several parts, as is shewn in the figure, while BC be left entire, the distance AB will always appear greater than CB . So also, if two equal squares be marked, one with horizontal and the other with vertical alternate dark and light bands, the former will appear higher, and the latter broader, than it really is. Hence short persons affect dresses horizontally striped in order to increase their apparent height, and very stout persons avoid longitudinal stripes. Two perfectly parallel lines or bands, each of which is crossed by slanting parallel short lines, will appear not parallel, but diverging or converging according to the direction of the cross-lines.



Again, when a short person is placed side by side with a tall person, the former appears shorter and the latter taller than each really is. The moon on the horizon appears larger than when at the zenith, partly because it can then be most easily compared with terrestrial objects, and partly perhaps because, from a conception we have of the heavens being flattened, we judge the moon to be farther off at the horizon than at the zenith; and being farther off, and yet subtending the same angle, must needs be judged larger. The absence of comparison may, however, have an opposite effect, as when a person looks larger in a fog; being seen indistinctly, he is judged to be farther off than he really is, and so appears to be proportionately larger, just as conversely distant mountains appear small, when in a clear atmosphere they are seen distinctly and so judged to be near. Indeed, our daily life is full of instances in which our direct perception is modified by circumstances. Among those circumstances previous experience is one of the most potent, and thus simple perceptions become mingled with what are in reality judgments, though frequently made unconsciously. But this intrusion of past experience into present perceptions and sensations is most obvious in binocular vision, to which we now turn.

SEC. 4. BINOCULAR VISION.

Corresponding or Identical Points.

Though we have two eyes, and must therefore receive from every object two sets of sensations, our perception of any object is under ordinary circumstances a single one; we see one object, not two. By putting either eye into an unusual position, as by squinting, we can render the perception double; we see two objects where one only exists. From which it is evident that singleness of perception depends on the image of the object falling on certain parts of each retina at the same time, these parts being so related to each other, that the sensations from each are blended into one perception; and it is also evident that the movements of the eyeballs are adapted to bring the image of the object to fall on these 'corresponding' or 'identical' parts, as they are called, of each retina.

When we look at an object with one eye the visual axis of that eye is directed to the object, and when we use two eyes the visual axes of the two eyes converge at the object, the eyeballs moving accordingly. The corresponding points of the two retinas are those on which the two images of the object fall when the visual axes converge at the object. Thus in Fig. 50, if Cc , Cc_1 be the two visual axes, c , c_1

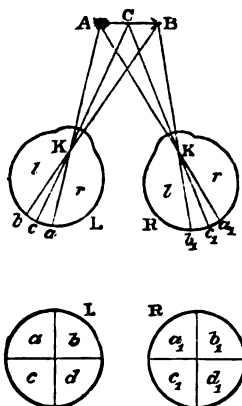

FIG. 50. DIAGRAM ILLUSTRATING CORRESPONDING POINTS.

L the left, R the right eye, K the optical centre, a_1, b_1, c_1 are points in the right eye corresponding to the points a, b, c in the left eye. The two figures below are projections of L the left and R the right retina. It will be seen that a on the *malar* side of L corresponds to a_1 on the *nasal* side of R .

being the centres of the foveæ centrales of the two eyes, then, the object ACB being seen single, the point a on the one retina will 'correspond' to or be 'identical' with the point a_1 on the other, and the point b in the one to the point b_1 in the other. Hence a point

lying anywhere on the right side of one retina, has its corresponding point on the right side of the other retina, and the points on the left of one correspond with those on the left of the other. Thus, while the upper half of the retina of the left eye corresponds to the upper half of the retina of the right eye, and the lower to the lower, the *nasal* side of the left eye corresponds with the *malar* side of the right, and the *malar* of the left with the *nasal* side of the right.

Since the blending of the two sensations into one only occurs when the two images of an object fall on these corresponding points of the two retinas, it is obvious that in single vision with two eyes the ordinary movements of the eyeballs must be such as to bring the visual axes to converge at the object so that the two images may fall on corresponding points. When the visual axes do not so converge, and when therefore the images do not fall on corresponding points, the two sensations are not blended into one perception and vision becomes double.

Movements of the Eyeballs.

The eye is virtually a ball placed in a socket, the orbit and the bulb forming a ball and socket-joint. In its socket-joint the optic ball is capable of a variety of movements, but it cannot by any voluntary effort be moved out of its socket.

It is stated that by a very forcible opening of the eyelids the eyeball may be slightly protruded; but this trifling locomotion may be neglected. By disease, however, the position of the eyeball in the socket may be materially changed.

Each eyeball is capable of rotating round an immobile centre of rotation, which has been found to be placed a little (1.77 mm.) behind the centre of the eye; but the movements of the eye round the centre are limited in a peculiar way. The shoulder-joint is a similar ball and socket-joint; and we know that we can not only move the arm up and down round a horizontal axis passing through the centre of rotation of the head of the humerus, and from side to side round a vertical axis, but we can also rotate it round its own longitudinal axis. When, however, we come to examine closely the movements of the eyeball we find, as was shewn by Donders, that though we can move it up and down round a horizontal axis, as when with fixed head we direct our vision to the heavens or to the ground, and from side to side, as when we look to left or right, and though by combining these two movements we can give the eyeball a variety of inclinations, we cannot, by a voluntary effort, rotate the eyeball round its longitudinal or visual axis. The arrangement of the muscles of the eyeball would permit of such a movement, but we cannot by any direct effort of will bring it about by itself; we can only effect it indirectly when we attempt to move the eyeballs in certain special ways.

If, when vision is directed to any object, the head be moved from side to side, the eyes do not move with it; they appear to remain stationary, very much as the needle of a ship's compass remains stationary when the head of the ship is turned. The change in the position of the visual axes to which the movement of the head would naturally give rise is met by compensating movements of the eye-balls; were it not so, steadiness of vision would be impossible.

There is one position of the eyes which has been called the *primary position*. It corresponds to that which may be attained by looking at the distant horizon with the head vertical and the body upright; but its exact determination requires special precautions. The visual axes are then parallel to each other and to the median plane of the head. All other positions of the eyes are called *secondary positions*. In a secondary position the visual line takes a new direction, and a plane drawn through the centre of rotation at right angles to the primary direction of the visual line acquires importance; for it was suggested by Listing, and proved by Donders and Helmholtz, that the change from the primary to any secondary position is brought about by a rotation of the eye round an axis lying in this plane. This law of the movements of the eye is known as Listing's law. The chief axes in this plane are the transverse axis of the eye, rotation round which causes the eye to move up and down, and the vertical axis, rotation round which causes the eye to move from side to side; rotation round other axes in the plane causes oblique movements. When, one eye being closed, we look with the other in the primary position at a vertical coloured stripe on a gray wall until a negative image of the stripe is produced, and then move the eye away from the stripe, the negative image remains vertical, however much the eye is moved either horizontally from side to side, or vertically up and down; in these movements, which are rotations round the vertical and transverse axes respectively, the relations of the retina to the visual line are unchanged; the meridian in which the negative image lies and which was vertical in the primary position, remains vertical in the new positions. A horizontal negative image similarly remains horizontal. If the eye be moved from the primary position in an oblique direction, the negative image, whether horizontal or vertical, becomes inclined; but Helmholtz¹ shewed that an oblique linear negative image also maintains its inclination when the eye is moved from the primary position, in the direction of the line of (or at right angles to the line of) the negative image; that here too the meridian passing through the visual line and the negative image remains unchanged; and that therefore the movement in this case also must be brought about by rotation round an axis at right angles to the plane passing through the meridian of the negative image (*i.e.* the visual line in its new direction) and the visual line in the primary position. In other words, just as a vertical or horizontal movement of the eye is a rotation round a horizontal or vertical axis in the plane of rotation spoken of above, so an oblique movement is a rotation round an oblique axis in the same plane and not in any way a rotation round the visual axis itself. When the horizontal or vertical negative image in the above experiment becomes inclined

¹ *Proc. Roy. Soc.* XIII. (1864) p. 186.

in an oblique movement of eye, its motion is similar to that of the spokes of a wheel; but this change of position of the meridians of the retina must not be confounded with the actual rotation of the eyeball on its visual axis.

All movements then starting from the primary position, whether rectangular or oblique, are executed without rotation of the eyeball; but this is not the case in moving from one secondary position to another. Moreover Listing's law holds good only so long as the visual axes remain parallel. When the visual axes are made to converge, some amount of rotation occurs, and that even when their horizontal direction, proper to them in the primary position, is maintained. The rotation is, with the exception of a particular position, still more marked when, as is usually the case during the convergence, the eyes are directed downwards.

It was once thought that the maintenance of the position of the eyeballs when the head was turned to the shoulders, while vision was directed to an object in front, was effected by means of a rotation of the eyeballs. This Donders proved to be an error, though some slight amount of rotation does take place. In various other movements of the eye too rotation occurs to a variable extent.

Muscles of the Eyeball. The eyeball is moved by six muscles, the *recti inferior, superior, internus* and *externus*, and the *obliqui inferior* and *superior*. It is found by calculation from the attachments and directions of the muscles, and confirmed by actual observation, that the six muscles may be considered as three pairs, each pair rotating the eye round a particular axis. The relative attachments and the axes of rotation are diagrammatically shewn in Fig. 51. Thus the rectus superior and the rectus inferior rotate the eye round a horizontal axis, which is directed from the upper end of the nose to the temple; the obliquus superior and obliquus inferior round a horizontal axis directed from the centre of the eyeball to the occiput; and the rectus internus and rectus externus round a vertical axis (which, being at right angles to the plane of the paper, cannot be shewn in the diagram), passing through the centre of rotation of the eyeball parallel to the medium plane of the head when the head is vertical. Thus the latter pair acting alone would turn the eye from side to side, the other straight pair acting alone would move the eye up and round, while the oblique muscles acting alone would give the eye an oblique movement. The rectus externus acting alone would turn the eye to the malar side, the internus to the nasal side, the rectus superior upwards, the rectus inferior downwards, the oblique superior downwards and outwards, and the inferior upwards and outwards. The recti superior and inferior in moving the eye up and down also turn it somewhat inward and at the same time give it a slight amount of rotation; but this is corrected if the oblique muscles act at the same time; and it is found that the rectus superior acting with the obliquus inferior moves the eye upwards, and the rectus inferior with the obliquus superior downwards in a vertical direction. In oblique movements also, the obliqui are always associated with

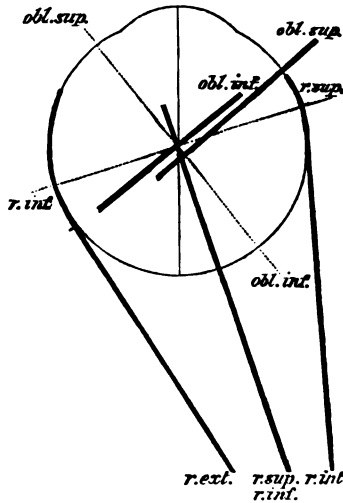

FIG. 51. DIAGRAM OF THE ATTACHMENTS OF THE MUSCLES OF THE EYE, AND OF THEIR AXES OF ROTATION, the latter being represented by dotted lines. The axis of rotation of the rectus externus and internus, being perpendicular to the plane of the paper, cannot be shown. (After Fick.)

the recti. Hence the various movements of the eyeball may be arranged as follows :

Straight movements.	{	Elevation.	Rectus superior and obliquus inferior.
		Depression.	Rectus inferior and obliquus superior.
		Adduction to nasal side.	Rectus internus.
		Adduction to malar side.	Rectus externus.
Oblique movements.	{	Elevation with adduction.	Rectus superior and internus with obliquus inferior.
		Depression with adduction.	Rectus inferior and internus with obliquus superior.
		Elevation with abduction.	Rectus superior and externus with obliquus inferior.
		Depression with abduction.	Rectus inferior and externus with obliquus superior.

Coordination of Visual Movements. Thus even in the movements of a single eye, a considerable amount of coordination takes place. When the eye is moved in any other than the vertical and horizontal meridians, impulses must descend to at least three muscles, and in such relative energy to each of the three as to produce the required inclination of the visual axis. But the coordination observed in binocular vision is more striking still. If the movements

of any person's eyes be watched it will be seen that the two eyes move alike. If the right eye moves to the right, so does also the left; and, if the object looked at be a distant one, exactly to the same extent; if the right eye looks up, the left eye looks up also, and so in every other direction. Very few persons are able by a direct effort of the will to move one eye independently of the other; though some, and among them a distinguished physiologist and oculist, have acquired this power. In fact, the movements of the two eyes are so arranged that in the various movements the images of any object should fall on the corresponding points of the two retinae, and that thus single vision should result. We cannot by any direct effort of our will place our eyes in such a position that the rays of light proceeding from any object shall fall on parts of the retina which do not correspond, and thus give rise to two distinct visual images. We can bring the visual axes of the two eyes from a condition of parallelism to one of great convergence, but we cannot, without special assistance, bring them from a condition of parallelism to one of divergence.

The stereoscope will enable us to create a divergence. If in a stereoscopic picture the distance between the pictures be increased so gradually that the impression of a single object be not lost, the visual axes may be brought to diverge. Helmholtz, while looking at a distant object with a prism before one eye, with the angle of the prism directed towards the nose and the vision of the object kept carefully single, found after turning the angle very slowly up or down, and keeping the image of the object single all the time, that on removing the prism a double image was for a moment seen; shewing that the eye before which the prism was placed had moved in disaccordance with the other. The double image however in a few seconds after the removal of the prism became single, on account of the eyes coming into accordance.

It is only when loss of coordination occurs, as in various diseases and in alcoholic or other poisoning, that the movements of the two eyes cease to agree with each other. It is evident then that when we look at an object to the right, since we thereby abduct the right eye and adduct the left, we throw into action the rectus externus of the right eye and the rectus internus of the left; and similarly when we look to the left we use the rectus externus of the left and the rectus internus of the right eye. When we look at a near object, and therefore converge the visual axes, we use the recti interni of both eyes; and when we look at a distant object, and bring the axes from convergence towards parallelism, we use the recti externi of both eyes. In the various movements of the eye there is therefore, so to speak, the most delicate picking and choosing of the muscular instruments. Bearing this in mind, it cannot be wondered at that the various movements of the eye are dependent for their causation on visual sensations. In order to move our eyes, we must either look at or for an object; when we wish to converge our axes, we look at some near object real or imaginary, and the

convergence of the axes is usually accompanied by all the conditions of near vision, such as increased accommodation and contraction of the pupil. And so with other movements.

The close association of the movements of the eye may be illustrated by the following case. Suppose the eyes, to start with, directed for the far distance, and that it is desired to direct attention to a nearer point lying in the visual line of the right eye. In this case no movement of the right eye is required; all that is necessary is for the left eye to be turned to the right, that is, for the rectus internus of the left eye to be thrown into action. But in ordinary movements the contraction of this muscle is always associated with either the rectus externus of the right eye (as when both eyes are turned to the right) or the rectus internus of that eye, as in convergence; the muscle is quite unaccustomed to act alone. This would lead us to suppose that in the case in question the contraction of the rectus internus of the left eye is accompanied by a contraction of both recti externus and internus of the right eye, keeping that eye in lateral equilibrium. And when we come to examine our own consciousness, we feel a sense of effort in the right as well as in the left eye, and the slight amount of rotation which accompanies convergence (see p. 439) may be discovered also in the right as well as in the left eye.

Such a complex coordination requires for its carrying out a distinct nervous machinery; and we have reasons for thinking that such a machinery exists in certain parts of the corpora quadrigemina. In the nates, Adamuk finds a common centre for both eyes, stimulation of the right side producing movements of both eyes to the left, of the left side movements to the right; while stimulation in the middle line behind causes a downward movement of both eyes with convergence of the axes, and in the front an upward movement with return to parallelism, both accompanied by the naturally associated movements of the pupil. Stimulation of various parts of the nates causes various movements, depending on the position of the spot stimulated. After an incision in the middle line, stimulation of the nervous centre on one side produces movements in the eye of the same side only.

The Horopter.

When we look at any object we direct to it the visual axes, so that when the object is small, the 'corresponding' parts of the two retinae, on which the two images of the object fall, lie in their respective foveae centrales. But while we are looking at the particular object the images of other objects surrounding it fall on the retina surrounding the fovea, and thus go to form what is called indirect vision. And it is obviously of advantage that these images also should fall on 'corresponding' parts in the two eyes. Now for any given position of the eyes there exists in the field of vision a certain line or surface of such a kind that the images of the points in it all fall on

corresponding points of the retina. A line or surface having this property is called a *Horopter*. The horopter is in fact the aggregate of all those points in space which are projected on to corresponding points of the retina; hence its determination in any particular case is simply a matter of geometrical calculation. In some instances it becomes a very complicated figure. The case whose features are most easily grasped, is a circle drawn in the plane of the two visual axes through the point of the convergence of the axes and the optic centres of the two eyes. It is obvious from geometrical relations that in Fig. 52 the images of any point in the circle will fall on corresponding points of the two retinae. When we stand upright and look at the distant horizon the horopter is (approximately, for normal long-sighted persons) a plane drawn through our feet, that is to say, is the ground on which we stand; the advantage of this is obvious.

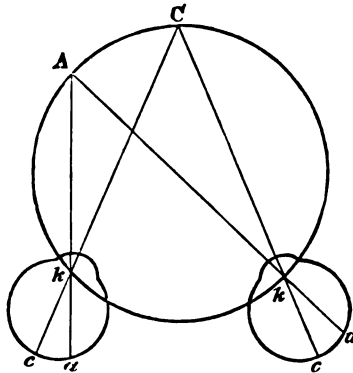

FIG. 52. DIAGRAM ILLUSTRATING A SIMPLE HOROPTER.

When the visual axes converge at *C*, the images *a a* of any point *A* on the circle drawn through *C* and the optical centres *k k*, will fall on corresponding points.

In determining the position of corresponding points it must be remembered, as Helmholtz¹ has shewn, that while the horizontal meridians of the two fields really correspond, it is the *apparent* and not the *real* vertical meridians which are combined into one image in binocular vision, and it is therefore by these that the corresponding points must be determined. If two areas be marked with lines nearly but not quite vertical, those on the right side inclining to the left, and those, on the left to the right, the former when judged by the right eye will appear vertical, though their slant will be apparent to the left eye, and the latter will appear vertical to the left eye but not to the right. When combined in a stereoscope picture, the lines in spite of their not being parallel will appear completely to coincide, shewing that it is the *apparent* position of the vertical lines which must be taken into consideration in determining corresponding points.

¹ *Proc. Roy. Soc.* XIII. (1864) p. 196.

SEC. 5. VISUAL JUDGMENTS.

Binocular vision is of use to us inasmuch as the one eye is able to fill up the gaps and imperfections of the other. For example, over and above the monocular filling up of the blind spot, of which we spoke in page 434, since the two blind spots of the two eyes, being each on the nasal side, are not 'corresponding' parts, the one eye supplies that part of the field of vision which is lacking in the other. And other imperfections are similarly made good. But the great use of binocular vision is to afford us means of forming visual judgments concerning the form, size, and distance of objects.

Judgment of Distance and Size. The perceptions which we gain simply and solely by our field of vision concern two dimensions only. We can become aware of the apparent size of any part of the field corresponding to any particular object, and of its topographical relations to the rest of the field, but no more. Had we nothing more to depend on, our sight would be almost valueless as far as any exact information of the external world was concerned. By association of the visual sensations with sensations of touch, and with sensations derived from the movements of the eyeballs required to make any such part of the field as corresponds to a particular object distinct, we are led to form judgments, *i.e.* to draw conclusions concerning the external world by means of an interpretation of our visual perceptions. Looking before us, we say we see a certain object of a certain colour nearly in front of us, or much on our right hand or much on our left; that is to say, we judge such an object to be in such a position because from the constitution of our brain, strengthened by all our experience, we associate such a part of our field of vision with such an object. The subjective visual complex sensation or perception is to us a symbol of the external object.

Even with one eye we can, to a certain extent, form a judgment, not only as to the position of the object in a plane at right angles to our visual axis, but also as to its distance from us along the visual axis. If the object is near to us, we have to accommodate for near vision; if far from us, to relax our accommodation mechanism so that the eye becomes adjusted for distance. The muscular sense (see chap. IV. sec. 4) of this effort enables us to form a judgment whether the object is far or near. Seeing the narrow range of our accommodation, and the slight muscular effort which it entails, all monocular judgments of distance must be subject to much error. Everyone who has tried to thread a needle without using both eyes, knows how great these errors may be. When, on the other hand, we use two eyes, we have still the variations in accommodation, and in addition have all the assistance which arises from the muscular effort of so directing the two eyes on the object that single vision shall result. When the object is near, we converge our visual axes; when distant, we bring them back towards parallelism. This necessary contraction of the

ocular muscles affords a muscular sense, by the help of which we form a judgment as to the distance of the object. Hence, when by any means the convergence which is necessary to bring the object into single vision is lessened, the object seems to become more distant; when increased, to move further away, as may be seen in the stereoscope.

The judgment of size is closely connected with that of distance. Our perceptions, gained exclusively from the field of vision, go no farther than the *apparent* size of the image, *i.e.* of the angle subtended by the object. The real size of the object can only be gathered from the apparent size of the image when the distance of the object from the eye is known. Thus perceiving directly the apparent size of the image, we judge the distance of the object giving the image, and upon that come to a conclusion as to its size. And conversely, when we see an object, of whose real size we are otherwise aware, or are led to think we are aware, our judgment of its distance is influenced by its apparent size. Thus when in our field of vision there appears the image of a man, knowing otherwise the ordinary size of man, we infer, if the image be very small, that the man is far off. The reason of the image being small may be because the man is far off, in which case our judgment is correct; it may be, however, because the image has been lessened by artificial dioptric means, as when the man is looked at through an inverted telescope, in which case our judgment becomes a delusion. So also an image on a screen when gradually enlarged seems to come forward, when gradually diminished seems to recede. In these cases the influence on our judgment of the muscular sense of binocular adjustment, or monocular accommodation, is thwarted by the more direct influence of the association between size and distance.

Judgment of Solidity. When we look at a small circle all parts of the circle are at the same distance from us, all parts are equally distinct at the same time, whether we look at it with one eye or with two eyes. When, on the other hand, we look at a sphere, the various parts of which are at different distances from us, a sense of the accommodation, but much more a sense of the binocular adjustment, of the convergence or the opposite of the two eyes, required to make the various parts successively distinct, makes us aware that the various parts of the sphere are unequally distant; and from that we form a judgment of its solidity. As with distance of objects, so with solidity, which is at bottom a matter of distance of the parts of an object, we can form a judgment with one eye alone; but our ideas become much more exact and trustworthy when two eyes are used. And we are much assisted by the effects produced by the reflection of light from the various surfaces of a solid object; so much so, that raised surfaces may be made to appear depressed, or *vice versa*, and flat surfaces either raised or depressed, by appropriate arrangements of shadings and shadow,

Binocular vision, moreover, affords us a means of judging of the solidity of objects, inasmuch as the image of any solid object which falls on to the right eye cannot be exactly like that which falls on the left, though both are combined in the single perception of the two eyes. Thus, when we look at a truncated pyramid placed in the middle line before us, the image which falls on the right eye is of the kind represented in Fig. 53 R, while that which falls on the left eye

FIG. 53.

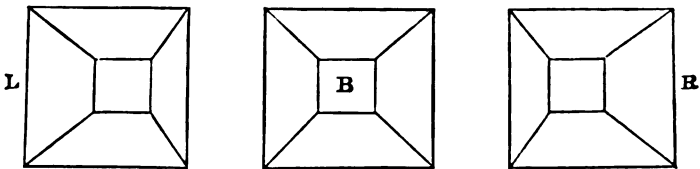

has the form of Fig. 53 L; yet the perception gained from the two images together corresponds to the form of which Fig. 53 B is the projection. Whenever we thus combine in one perception two dissimilar images, one of the one, and the other of the other eye, we judge that the object giving rise to the images is solid.

This is the simple principle of the stereoscope, in which two slightly dissimilar pictures, such as would correspond to the vision of each eye separately, are, by means of reflecting mirrors, as in Wheatstone's original instrument, or by prisms, as in the form introduced by Brewster, made to cast images on corresponding parts of the two retinas so as to produce a single perception. Though each picture is a surface of two dimensions only, the resulting perception is the same as if a single object, or group of objects, of three dimensions had been looked at.

It might be supposed that the judgment of solidity which arises when two dissimilar images are thus combined in one perception, was due to the fact that all parts of the two images cannot fall on corresponding parts of the two retinas at the same time, and that therefore the combination of the two needs some movement of the eyes. Thus, if we superimpose R on L (Fig. 53), it is evident that when the bases coincide the truncated apices will not, and *vice versa*; hence, when the bases fall on corresponding parts, the apices will not be combined into one image, and *vice versa*; in order that both may be combined, there must be a slight rapid movement of the eyes from the one to the other. That, however, no such movement is necessary for each particular case is shewn by the fact that solid objects appear as such when illuminated by an electric spark, the duration of which is too short to permit of any movements of the eyes. If the flash occurred at the moment that the eyes were binocularly adjusted for the bases of the pyramids, the two apices not falling on exactly corresponding parts would give rise to two perceptions, and the whole object ought to appear confused. That it does

not, but, on the contrary, appears a single solid, must be the result of cerebral operations, resulting in what we have called a judgment.

Struggle of the two Fields of Vision. If the images of two surfaces, one black and the other white, are made to fall on corresponding parts of the eye, so as to be united into a single perception, the result is not always a mixture of the two impressions, that is a grey, but, in many cases, a sensation similar to that produced when a polished surface, such as plumbago, is looked at; the surface appears brilliant. The reason probably is because when we look at a polished surface the amount of reflected light which falls upon the retina is generally different in the two eyes; and hence we associate an unequal stimulation of the two retinas with the idea of a polished surface. So also when the impressions of two colours are united in binocular vision, the result is in most cases not a mixture of the two colours, as when the same two impressions are brought to bear together at the same time on a single retina, but a struggle between the two colours, now one, and now the other, becoming prominent, intermediate tints however being frequently passed through. This may arise from the difficulty of accommodating at the same time for the two different colours (see p. 412); if two eyes, one of which is looking at red, and the other at blue, be both accommodated for red rays, the red sensation will overpower the blue, and *vice versa*. It may be however that the tendency to rhythmic action, so manifest in other simpler manifestations of protoplasmic activity, makes its appearance also in the higher cerebral labours of binocular vision.

SEC. 6. THE PROTECTIVE MECHANISMS OF THE EYE.

The eyeball is protected by the eyelids, which are capable of movements called respectively opening and shutting the eye. The eye is shut by the contraction of the orbicularis muscle, carried out either as a reflex or voluntary act, by means of the facial nerve. The eye is opened chiefly by the raising of the upper eyelid, through the contraction of the levator palpebræ carried out by means of the third nerve. The upper eyelid is also raised and the lower depressed, the eye being thus opened, by means of plain muscular fibres existing in the two eyelids and governed by the cervical sympathetic. The shutting of the eye as in winking is in general effected more rapidly than the opening.

The eye is kept continually moist partly by the secretion of the glands in the conjunctiva, and of the Meibomian glands, but chiefly by the secretion of the lachrymal gland. Under ordinary circumstances the fluid thus formed is carried away by the lachrymal canals into the nasal sac and thus into the cavity of the nose. When the secretion becomes too abundant to escape in this way it overflows on to the cheeks in the form of tears.

If a quantity of tears be collected, they are found to form a clear faintly alkaline fluid, in many respects like saliva, containing about 1 p. c. of solids, of which a small part is proteid in nature. Among the salts present sodium chloride is conspicuous.

The nervous mechanism of the secretion of tears, in many respects, resembles that of the secretion of saliva. A flow is usually brought about either in a reflex manner by stimuli applied to the conjunctiva, the nasal mucous membrane, tongue, optic nerve, &c. or more directly by emotions. Venous congestion of the head is also said to cause a flow. The efferent nerves belong either to the cerebro-spinal system, (the lachrymal and orbital branches of the fifth nerve,) or arise from the cervical sympathetic, the afferent nerves varying according to the exciting cause.

Herzenstein¹ and Wolferz² shewed that stimulation of the peripheral end of the divided lachrymal branch of the fifth nerve produced a copious flow of tears. After division of this branch stimulation of the nasal mucous membrane produced no increased flow: the reflex act could not be carried out. Stimulation of the orbital (subcutaneous malar) branch also produced an increased flow but not to so marked an extent, or so constantly as did stimulation of the lachrymal branch. According to Wolferz³ and Reich⁴, stimulation of the upper end of the divided cervical sympathetic also produces an increased flow, even after division of the lachrymal nerve; Herzenstein's results on this point were uncertain or negative. Reich also maintains that stimulation of the peripheral portion of the divided *root* of the fifth nerve does not excite the gland, but that, after such a division, the flow of tears may be excited in a reflex manner as usual. This would shew that the secretory fibres in the lachrymal branch do not belong properly to the fifth nerve. Reich believes that they come however not from the facial, as might by analogy with the submaxillary gland be supposed, but from the sympathetic.

The act of winking undoubtedly favours the passage of tears through the lachrymal canals into the nasal sac, and hence when the orbicularis is paralysed tears do not pass so readily as usual into the nose; but the exact mechanism by which this is effected has been much disputed. According to some authors, the contraction of the orbicularis presses the fluid onwards out of the canals, which, upon the relaxation of the orbicularis, dilate and receive a fresh quantity. Demtschenko⁵ states that a special arrangement of muscular fibres keeps the canals open even during the closing of the lids, so that the pressure of the contraction of the orbicularis is able to have full effect in driving the tears through the canals.

¹ Du Bois-Reymond's *Archiv*, 1867, p. 651.

² *Dissertatio*. Henle and Meissner's *Bericht*, 1871, p. 245.

³ *Op. cit.*

⁴ *Archiv f. Ophthalmol.* XIX. (1873) p. 38.

⁵ Hofmann and Schwabe's *Bericht*, 1873, p. 530.

CHAPTER III.

HEARING, SMELL, AND TASTE.

SEC. 1. HEARING.

As in the eye, so in the ear, we have to deal first with a nerve of special sense, the stimulation of which gives rise to a special sensation; secondly with terminal organs through which the physical changes proper to the special sense are enabled to act on the nerve; and thirdly with subsidiary apparatus, by which the usefulness of the sense is increased. The central connections of the auditory nerve are such that whenever the auditory fibres are stimulated, whether by means of the terminal organs in the usual way or by the direct application of stimuli, electrical, mechanical, &c., the result is always a sensation of sound. Just as stimulation of the optic fibres produces no other sensation than that of light, so stimulation of the auditory fibres produces no other sensation than that of sound¹. The terminal organs of the auditory nerve are of two kinds: the complicated organ of Corti in the cochlea, and the epithelial arrangements of the maculae and cristae acusticae in other parts of the labyrinth. Waves of sound falling on the auditory nerve itself, produce no effect whatever; it is only when by the medium of the endolymph they are brought to bear on the delicate and peculiar epithelium cells which constitute the peripheral terminations of the nerve, that sensations of sound arise. Such delicate structures are for the sake of protection naturally withdrawn from the surface of the body where they would be subject to injury. Hence the necessity of an acoustic apparatus, forming the middle and external ear, by which the waves of sound are most advantageously conveyed to the terminal organs.

The Acoustic Apparatus.

Waves of sound can and do reach the endolymph of the labyrinth by direct conduction through the skull. Since however sonorous vibrations are transmitted with great difficulty from the air to solids and liquids, and most sounds come to us through the air, some special

¹ It will be seen later on that there are reasons for thinking that impulses passing along the auditory nerve may give rise to other effects than auditory sensations.

apparatus is required to transfer the aerial vibrations to the liquids of the internal ear. This apparatus is supplied by the tympanum and its appendages.

The concha. The use of this, as far as hearing is concerned, is to collect the waves of sound coming in various directions, and to direct them on to the membrana tympani. In ourselves of moderate service only, in many animals it is of great importance.

The membrana tympani. It is a characteristic property of stretched membranes that they are readily thrown into vibration by aerial waves of sound. The membrana tympani, from its peculiar conformation, being funnel-shaped with a depressed centre surrounded by sides gently convex outwards, is peculiarly susceptible to sonorous vibrations, and is most readily thrown into corresponding movements when waves of sound reach it by the meatus. It has moreover this useful feature, that unlike other stretched membranes, it has no marked note of its own. It is not thrown into vibrations by waves of a particular length more readily than by others. It answers equally well within a considerable range, to vibrations of very different wavelengths. Had it a fundamental tone of its own, we should be distracted by the prominence of this note in most of the sounds we hear.

The auditory ossicles. The malleus, the handle of which descending forwards and inwards, is attached to the membrana tympani, and the incus, whose long process is connected by means of its os orbiculare or lenticular process and the stapes to the fenestra ovalis, form together a body which rotates round an axis, passing through the short process of the incus, the bodies of the incus and malleus, and the processus gracilis of the malleus. When the malleus is carried inwards, the incus moves inwards too, and when the malleus returns to its position, the incus returns with it, the peculiar saddle-shaped joint with its catch teeth permitting this movement readily, but preventing the stapes being pulled back when the membrana tympani with the malleus is, for any reason, pushed outwards more than usual; the joint then gapes, so as to permit the malleus to be moved alone. Various ligaments, the superior or suspensory, anterior, and external, also serve to keep the malleus in place. The whole series of ossicles may be regarded as a lever, the fulcrum of which is situated at the ligamental attachment of the short processus of the incus to the posterior wall of the tympanum. The long, malleal arm of this lever is about $9\frac{1}{2}$ mm., the short, stapelial, $6\frac{1}{2}$ mm. in length; hence the movements of the stapes are less than those of the tympanum; but the loss in amplitude is made up by a gain of force, which is in itself an obvious advantage.

Thus every movement of the tympanic membrane is transmitted through this chain of ossicles to the membrane of the fenestra ovalis, and so to the perilymph of the labyrinth; the vibrations of the

tympanic membrane are conveyed with increased intensity, though with diminished amplitude, to the latter. That the bones thus move *en masse* has been proved by recording their movements in the usual graphic method. A very light style attached to the incus or stapes is made to write on a travelling surface; when the *membrana tympani* is thrown into vibrations by a sound, the curves described by the style indicate that the chain of bones moves with every vibration of the tympanum. On the other hand, the comparatively loose attachments of the several bones is an obstacle to the molecular transmission of sonorous vibrations through them. Moreover, sonorous vibrations can only be transmitted to or pass along such bodies as either are very long compared to the length of the sound-waves, or, as in the case of membranes and strings, have one dimension very much smaller than the others. Now the bones in question are not exceedingly thin in any dimension, but are in all their dimensions exceedingly small compared with the length of the vibrations of even the shrillest sounds we are capable of hearing; hence they must be useless for the molecular propagation of vibrations.

The tensor tympani muscle is of use in preventing the *membrana tympani* being pushed out far. Its contractions, by rendering the membrane more tense, lessen the amount of vibration, and moderate the apparent loudness of a sound. Its activity in this direction is regulated by a reflex action, but in some persons it seems to be partly under the dominion of the will; since a peculiar crackling noise which these persons can produce at pleasure appears to be caused by a contraction of the tensor tympani.

The stapedius muscle is supposed to regulate the movements of the stapes, and especially to prevent its base being driven too far into the *fenestra ovalis* during large or sudden movements of the *membrana tympani*.

A contraction of the stapedius by itself would have the effect of pulling the hinder end of the base of the stapes out of, and of pushing the front end into, the *fenestra ovalis*; and this might give rise to a wave in the *perilymph*. For speculations on this and on the reason why the stapedius is governed by the facial and the tensor tympani by the fifth nerve, see Budge¹.

The so-called *laxator tympani* is considered² to be not a muscle at all, but a part of the ligamentous supports of the malleus.

The Eustachian Tube. This serves to maintain an equilibrium of pressure between the external air and that within the tympanum, and to serve as an exit for the secretions of that cavity. Were the tympanum permanently closed the vibrations of the *membrana tympani* would be injuriously affected by variations of pressure occurring either inside or outside.

¹ Pflüger's *Archiv*, (1874) ix. 460.

² Helmholtz, Pflüger's *Archiv*, i. (1868) 1. Henle, *Anatomie*, ii. 746.

The Eustachian tube is undoubtedly open during swallowing, but it is still disputed whether it remains permanently open, or is opened only at intervals.

Auditory Sensations.

Each vibration communicated by the stapes to the perilymph travels as a wave over the vestibule, the semicircular canals, and other parts of the labyrinth, and is there transmitted to the endolymph; it passes on from the vestibule into the scala vestibuli of the cochlea, and descending the scala tympani, ends as an impulse against the membrane of the fenestra rotunda. In the maculæ and cristæ the vibrations of the endolymph are supposed to throw into corresponding vibrations the so-called auditory hairs. In the cochlea the vibrations of the perilymph are supposed to throw into vibrations the basilar membrane with the superimposed organ of Corti, consisting of the rods of Corti with the inner and outer hair-cells. The vibrations thus transmitted to these structures give rise to nervous impulses in the terminations of the auditory nerves, and these impulses reaching certain parts of the brain produce what we call auditory sensations. We are accustomed to divide our auditory sensations into those caused by noises and those caused by musical sounds. It is the characteristic of the latter that the vibrations which constitute them are periodical; they occur and recur at regular intervals. When no periodicity is present in the vibrations, when the repetition of the several vibrations is irregular, or the period so complex as not to be readily appreciated, the sensation produced is that of a noise. There is however no abrupt line between the two. Between a pure and simple musical sound produced by a series of vibrations each of which has exactly the same wave-length, and a harsh noise, in which no consecutive vibrations may be alike, there are numerous intermediate stages.

In both noises and musical sounds we recognise a character which we call loudness. This is determined by the amplitude of the vibrations; the greater the disturbance of the air (or other medium) the louder the sound. In a musical sound we recognise also a character which we call pitch. This is determined by the wave-length of the vibrations; the shorter the wave-length, the larger the number of consecutive vibrations which fall upon the ear in a second, the higher the pitch. We are able to speak of a whole series of tones or musical sounds of different pitch, from the lowest to the highest audible tone. And even in many noises we can, to a certain extent, recognise a pitch, indicating that among the multifarious vibrations there is a periodicity with fixed intervals.

Lastly, we distinguish musical sounds by their quality; the same note sounded on a piano and on a violin produce very different sensations, even when a series of vibrations having in each case the same period of repetition is set going. This arises from the fact that the

musical sounds generated by most musical instruments are not simple but compound vibrations. When the note C in the treble for instance is struck on the piano, it is perfectly true that a series of vibrations with a period characteristic of the pure tone of the treble C are started, but it is also true that those vibrations are accompanied by other vibrations with periods characteristic of the C in the octave above, of the G above that, of the C in the next octave, and of the E above that. And it is the effect of all these vibrations together on the ear which causes the sensation which we associate with the sound of the treble C on the piano. Almost all musical sounds are thus composed of what is called a 'fundamental tone' accompanied by a number of 'overtones.' And the overtones varying in number and relative prominence in different instruments, give rise to a difference in the sensation caused by the whole tone. So that while the fundamental tone determines the pitch of the sound, the quality of the sound is determined by the number and relative prominence of the overtones. In a similar way we distinguish the quality of noises, such as a banging, crackling, or rustling noise, by the predominance of vibrations having a less orderly character, and recurring less regularly than those of a musical sound.

Since we have a very considerable appreciation, capable by exercise of astonishing enlargement, of the loudness, pitch, and quality of a wide range of noises and musical sounds, it is clear that, within the limits of hearing, each vibration or series of vibrations must produce its effect on the auditory nerves, according to the measure of its intensity and period. Out of those effects, out of the sensory impulses to which the several vibrations thus give rise, are generated our sensations of the noise or of the sound.

The vibrations of a musical sound (and since noises are so imperfectly understood, we may, with benefit, chiefly confine ourselves to musical sounds), as they pass through the air (or other medium) are not discrete; the vibrations corresponding to the fundamental tone and overtones do not travel as so many separate waves; they all together form one complex disturbance of the medium; and it is as one *composite* wave that the sound falls on the *membrana tympani*, and passing through the auditory apparatus, breaks on the terminations of the auditory nerve. And when two or more musical sounds are heard at the same time, the same fusion of waves occurs. Since we can distinguish several tones reaching our ear at the same time, it is clear that we must possess in our minds or in our ears some means of analysing these composite waves of sound which fall on our acoustic organs, and of sorting out their constituent vibrations.

There is at hand a simple and easy physical method of analysing composite sounds. If a person standing before an open piano sings out any note, it will be observed that a number of the strings of the piano will be thrown into vibration, and on examination it will be found that those strings which are thus set going correspond in pitch to the fundamental tone and to the several overtones of the note

sung. The note sung reaches the strings as a complex wave, but these strings are able to analyse the wave into its constituent vibrations, each string taking up those vibrations and those vibrations only which belong to the tone given forth by itself when struck. If we suppose that each terminal fibril of the auditory nerve is connected with an organ so far like a piano-string that it will readily vibrate in response to a series of vibrating impulses of a given period and to none other, and that we possess a number of such terminal organs sufficient for the analysis of all the sounds which we can analyse, and that each terminal organ so affected by particular vibrations gives rise to a sensory impulse and thus to a sensation of a distinct character—if we suppose these organs to exist, our appreciation of sounds is in a large measure explained. In the organ of Corti we find structures the arrangement of which irresistibly suggests to us that these are the organs we are seeking. We have only to suppose that of the long series of rods of Corti, varying regularly as these do from the bottom to the top of the spiral, in length and in the span of their arch, each pair will vibrate in response to a particular tone, and the whole matter seems explained. But the more the subject is inquired into, the more complex and difficult it appears; and we are obliged to conclude that the part played by the rods of Corti is only a subordinate part of the function of the whole organ of Corti.

In the first place, it is difficult to see how the rods of Corti, even if they are thrown into vibration, can originate sensory impulses, for the fibrils of the auditory nerve terminate in the inner and outer hair-cells, and it is in these cells, and not along the course of the fibrils as they pass under and between the rods of Corti, that the sensory impulses must begin. In the second place, the variation in length of the fibres along the series is insufficient for the work assigned to them. Moreover, they appear not to be elastic. Lastly, they are wholly absent in birds, who very clearly can appreciate musical sounds. This last fact proves indubitably that the rods in question are not absolutely essential for the recognition of tones. In the face of these difficulties it has been suggested that the basilar membrane, which is present in birds, and which, being tense radially but loose longitudinally, *i.e.* along the spiral of the cochlea, may, as physical investigations shew, be considered as consisting of a number of parallel radial strings, each capable of independent vibrations, is the sought-for organ of analysis. According to this view, a particular vibration reaching the scala tympani of the cochlea throws into sympathetic vibrations a small portion of the basilar membrane, the vibrations of which in turn so affect the structures overlying it, that sensory impulses are generated. These sensory impulses reaching the brain give rise to a corresponding sensation of a particular tone. According to Hensen the radial dimensions of the basilar membrane in man diminish downwards from $\cdot 495$ mm. at the hamulus to $\cdot 04125$ mm. near the bottom of the spiral, giving a much greater range than the rods of Corti, the difference in length of which is simply between $\cdot 048$ and $\cdot 085$ mm. for the inner, and between $\cdot 019$ and $\cdot 085$ for the outer, fibres.

The remarkable reticular membrane which has such peculiar relations with the hair-cells, and through them with the basilar membrane, must, one might imagine, have some special function; but it is impossible to assign to it any satisfactory duty. The structural arrangements seem, if anything, to indicate that when a segment of the basilar membrane is thrown into vibrations, the overlying hair-cells, reticular membrane, and rods of Corti vibrate *en masse* together with it. But this renders the whole matter still more difficult. Indeed the whole subject is in the highest degree obscure, and the most we can say is that the organ of Corti as a whole seems to be in some way connected with the appreciation of tones, but that at present it is very hazardous to attempt to explain how it acts, or to assign particular functions to particular parts. The distinction between the inner and outer hair-cells seems to be very parallel to that between the rods and the cones of the retina; but even this analogy may be a fallacious one.

Hensen has observed that among the auditory hairs of the crustacea, some will vibrate to particular notes; but the auditory hairs of the mammal are far too much of the same length to permit the supposition that they can act as organs of analysis.

If the organ of Corti is the means by which we appreciate tones, it is evident that by it also we must be able to estimate loudness, for the quality of a musical sound is dependent on the relative intensity, as well as on the nature, of the overtones. And since noise is at best but confused music, the cochlea must be a means of appreciating noises as well as sounds. But this would leave nothing whatever for the rest of the labyrinth to do as far as the appreciation of sound was concerned. We have no reason to think that any impulse which could affect the hair-cells of the macule and cristæ could not affect the hair-cells of the organ of Corti. That this part of the ear is however concerned in conscious hearing is shewn by its being the only auditory organ in the ichthyopsida, unless we suppose that in the higher vertebrates its function has been wholly transferred to the cochlea. That the semicircular canals have duties apart from conscious hearing we shall shew later on.

Concerning the function of the other parts of the internal ear we know very little. The otoliths have been supposed to intensify the vibrations of the endolymph; but since apparently they are lodged in a quantity of mucus it is probable that they really act as dampers. A similar damping action has been suggested for the membrane of Corti (*membrana tectoria*) overhanging the fibres and hair-cells; and some writers have supposed that muscular fibres present in the planum semilunare may by tightening the basilar membrane serve as a sort of accommodating mechanism.

It must however be borne in mind that even making the fullest allowance for the assistance afforded us by the organ of Corti, the appreciation of any sound is ultimately a mental act. The analysis of the vibrations by the fibres of Corti or the basilar membrane is simply preliminary to a synthesis of the sensory impulses so generated into a complex sensation. We do not receive a distinct series of specific auditory impulses resulting in a specific sensation for every possible variation in the wave-length of sonorous vibrations any more than we receive a distinct series of specific visual impulses for every

possible wave-length of luminous vibrations. In each case we have probably a number of primary sensations, from the various mingling of which, in different proportions, our varied complex sensations arise; the difference between the eye and the ear being that whereas in the former the number of primary sensations appears to be limited to three, viz. red, green, and violet; in the latter, thanks to the organ of Corti, the number is very large; what the exact number is we cannot at present tell. Our appreciation of a sound is at bottom an appreciation of the combined effect produced by the relative intensities to which the primary auditory sensations are, with the help of the organ of Corti, excited by the sound.

Whatever be the explanation of the manner in which our distinct auditory sensations arise, the range and precision of our appreciation of musical sounds is very great. Vibrations with a recurrence below 30 a second are unable to produce a sensation of sound; if the waves are powerful enough we may feel them, but we do not hear them if the vibrations are simple, and such as would give rise to a pure tone; if the fundamental tone is accompanied by overtones we may hear these and are thus apt to say we hear the former when in reality we only hear the latter. The note of the 16-foot organ pipe, 33 vibrations a second, gives us the sensation of a droning sound. A tone of 40 vibrations is however quite distinct. In the other direction it is possible to hear a note caused by 38,000 vibrations a second, though the limit for most persons is far lower, about 16,000¹. Some persons hear grave sounds more easily than high ones, and *vice versa*. This may be so pronounced as to justify the subjects being spoken of as deaf to grave or high tones respectively.

The power of distinguishing one note from another varies, as is well known, in different individuals, according as they have or have not a 'musical ear.' A well-trained ear can distinguish between 1000 and 1001 vibrations a second. The range of an ordinary appreciation of tones lies between 40 and 4000 vibrations a second, *i. e.* between the lowest bass C (C₁ 33 vibrations) and the highest treble C (C^s 4224 vibrations) of the piano; tones above and below these, even when audible, being distinguished from each other with great difficulty.

When two consecutive sounds follow each other at a sufficiently short interval the sensations are fused into one. In this respect auditory sensations are of shorter duration than ocular sensations. When ocular sensations are repeated ten times in a second they become fused (p. 416), whereas the ticks of a pendulum beating 100 in a second are readily audible as distinct sounds. When two tuning-forks not quite in tune are struck together the interference of the vibrations gives rise to an alternating rise and fall of the sound, known as 'beats.' When the beats follow each other as rapidly as 132 in a

¹ Helmholtz, *Tonempfindungen*, p. 30. Cf. Preyer (*Grenzen der Tonwahrnehmung. Physiolog. Abhandlungen*, i. 1, 1876), who places the grave limit as varying from 15 to 24, and the acute limit from 16,000 to 40,000 vibrations per sec.

second they cease to be recognized, that is to say, the sensations which they cause become fused. Just before they disappear they give a peculiar disagreeable roughness to the sound. The pleasure given by musical sounds depends largely on the absence of this incomplete fusion of sensations.

Corresponding to entoptic phenomena there are various *entotic* phenomena, sensations or modifications of sensations originating in the tympanum or in the labyrinth; moreover sensations of sound may rise in the auditory nerve or in the brain itself, without any vibration whatever falling on the labyrinth.

Auditory Judgments.

In seeking for the cause of our visual sensations we invariably refer to the external world. The sensation caused by a direct stimulation of the optic nerve or retina by a blow or a galvanic current, we identify with that caused by a flash of light. A sensation arising from any stimulation of the left side of our retina we regard as caused by some object on the right-hand side of our external visible world. In a similar way, but to a less extent, we project our auditory sensations into the world outside us, and when the auditory nerve is affected we seek the cause in vibrations starting at a greater or less distance from us. We do not think of the sound as originating in the ear itself.

This mental projection of the sound is much more complete when the ear is stimulated by vibrations reaching it through the membrana tympani than when the vibrations are conducted by the solids of the head directly to the perilymph of the labyrinth. When the meatus externus is filled with fluid and the vibrations of the membrana tympani are in consequence interfered with, the apparent outwardness of sounds is to a very large extent lost; sounds, however caused, seem under these circumstances to arise in the ear. Hence it would seem that our judgment of the objectiveness of sounds is largely dependent on coincident sensations derived in some way or other from the tympanum.

When sounds impinge on the solids of the head, as when a watch is held between the teeth, the membrana tympani is still functional. Vibrations are conveyed from the temporal bone to it and hence pass in the usual way, in addition to those transmitted directly from the bone, to the perilymph.

Our judgment of the **distance** of sounds is very limited. A sound whose characters we know appears to us near when it is loud, and far off when it is faint. A blindfold person will be unable to distinguish between the difference of intensity produced by a tuning-fork being held before him, first with the broad edge of the fork towards him and then with the narrow edge, and the difference caused by the removal of the tuning-fork to a distance. We can on

the whole better appreciate the distance of noises than of musical sounds.

Our judgment of the **direction** of sounds is also very limited. Our chief aid in this is the position in which we have to place the head in order that we may hear the sound to the best advantage. If a tuning-fork be held in the median vertical plane over the head, though it is easy to recognize it as being in the median plane, it becomes very difficult when the eyes are shut to say what is its position in that plane, *i. e.* whether it is more towards the front or back of the head. In this respect, too, our appreciation is more accurate in the case of noises than of musical sounds, with the exception of those given out by the human voice, the direction of which can be judged better than even that of a noise.

SEC. 2. SMELL.

Odoriferous particles present in the inspired air passing through the lower nasal chambers diffuse into the upper nasal chambers, and falling on the olfactory epithelium produce sensory impulses which, ascending to the brain, give rise to sensations of smell. We may presume that the sensory impulses are originated by the contact of the odoriferous particles with the peculiar rod-shaped olfactory cells described by Max Schultze; but we are as much in the dark about this matter as about the development of visual sensory impulses in the rods and cones or auditory sensory impulses in the organ of Corti.

The subsidiary apparatus of smell is exceedingly meagre. By the forced nasal inspiration, called sniffing, we draw air so forcibly through the nostrils that currents pass up into the upper as well as the lower nasal chambers; and thus a more complete contact of the odoriferous particles with the olfactory membrane than that supplied by mere diffusion is provided for.

We have every reason to think that any stimulus applied to the olfactory nerve will produce a sensation of smell; but the proof of this is not so clear as in the case of the optic and auditory nerves. We are, however, subject to sensations of smell not caused by objective odours. The olfactory membrane is the only part of the body in which odours as such can give rise to any sensations; and the sensations to which they give rise are always those of smell. The mucous membrane of the nose is however also an instrument for the development of afferent impulses other than the specific olfactory ones. Chemical stimulation of the nasal membrane by pungent substances such as ammonia gives rise to a sensation distinct from that of smell, a sensation which affords us no information concerning the chemical nature of the stimulus, and which is indistinguishable from the sensations produced by chemical stimulation of other surfaces equally sensitive to chemical action. It is probable, but not certain, that these two kinds of sensations are conveyed by different nerves, the former by the olfactory, the latter by the fifth nerve.

For the development of smell it appears necessary that the odorous particles should be conveyed to the nasal membrane in a gaseous medium, or at least that the surface of the membrane should be exposed to air. When the nostril is filled with rose-water, the odour of roses is not perceived; and simply filling the nostrils with distilled water suspends for a time all smell, the sense returning gradually after the water has been removed.

Each odour that we smell causes a specific sensation, and we are not only able to recognize a multitude of distinct odours, but also to distinguish individual odours in a mixed smell.

As in the previous senses, we project our sensation into the external world; the smell appears to be not in our nose, but somewhere outside us. We can judge of the position of the odour however even less definitely than we can of that of a sound.

The sensation takes some time to develop after the contact of the stimulus with the olfactory membrane, and lasts very long. When the stimulus is repeated the sensation very soon dies out; the sensory terminal organs speedily become exhausted. Mental associations cluster more strongly round sensations of smell than round any other impressions we receive from without. And reflex effects are very frequent, many people fainting in consequence of the contact of a few odoriferous particles with their olfactory cells.

Apparently the larger the surface the more intense the sensation; animals with acute scent having a proportionately large area of olfactory membrane. The quantity of material required to produce an olfactory sensation may be, as in the case of musk, almost immeasurably small.

When two different odours are presented to the two nostrils, an oscillation of sensation similar to that spoken of in binocular vision (p. 448) takes place.

The assertion that the olfactory nerve is the nerve of smell has been disputed. Majendie asserted that animals could still smell after the removal of the olfactory lobes; but the stimulus which he applied was ammonia, in no way a test of smell. Biffi, operating on blind puppies, came to the conclusion that true smell disappeared after destruction of the olfactory lobes. Bernard¹ records a case of a woman who had been a cook, and who appeared to have possessed the sense of smell, and yet in whom the olfactory lobes were absent. On the other hand, it is stated that section or injury of the fifth nerve causes a loss of smell though the olfactory nerve remains intact; but in these cases it has not been shewn that the olfactory membrane remains intact, and it is quite possible that, as in the case of the eye, changes may take place in the nasal membrane as the result of the injury to the fifth nerve, sufficient to prevent its performing its usual functions.

¹ *Syst. Nerv.* II. 228.

SEC. 3. TASTE.

The word taste is frequently used when the word smell ought to be employed. We speak of 'tasting' odoriferous substances, such as an onion, wines, &c., when in reality we only smell them as we hold them in our mouth; this is proved by the fact that the so-called taste of these things is lost when the nose is held, or the nasal membrane rendered inert by a catarrh.

The terminal organs of the sense of taste thus more strictly defined, are the endings of the glossopharyngeal and lingual nerves in the mucous membrane of the tongue and palate, those nerves serving as the special nerves of taste. The subsidiary apparatus is confined to the tongue and lips, which by their movements assist in bringing the sapid substances into contact with the mucous membrane of the mouth.

The so-called gustatory buds cannot be regarded as specific organs of taste, since they occur in places (*e.g.* epiglottis) wholly devoid of taste.

Though we can hardly be said to project our sensation of taste into the external world, we assign to it no subjective localisation. When we place quinine in our mouth, the resulting sensation of taste gives us no information as to where the quinine is, though we may learn that by concomitant general sensations arising in the buccal mucous membrane.

We recognize a multitude of distinct tastes, which may be broadly classified into acid, saline, bitter and sweet tastes. Sapid substances have the power of producing these sensations by virtue of their chemical nature. But other stimuli will also give rise to sensations of taste. When the tongue is tapped, a taste is felt; and when a constant current is passed through the mouth, an alkaline taste is developed when the anode, and an acid taste when the kathode, is placed on the tongue. It is probable that in these cases the terminal organs are affected. When hot or pungent substances are introduced into the mouth, sensations of general feeling are excited, which obscure any strictly gustatory sensations which may be present at the same time.

Though analogy would lead us to suppose that a stimulus applied to any part of the course of the real gustatory fibres of either the glossopharyngeal or lingual nerves, would give rise to a sensation of taste and nothing else, the proof is not forthcoming; since both these nerves are mixed nerves containing other afferent fibres as well as those of taste.

When the constant current is used as a means of exciting taste, gustatory sensations are found to be developed in the back, edges and tip of the tongue, the soft palate with the anterior pillar of the fauces and a small tract of the posterior part of the hard palate. They are absent from the anterior and middle dorsum, and under surface of the

tongue, the front portion of the hard palate, the posterior pillars of the fauces, the gums and the lips. Sapid substances are unsuitable as a test for this purpose, on account of their rapid diffusion. Bitter substances produce most effect when placed on the back of, and sweet substances when placed on the tip of the tongue. It is said that acids are best appreciated by the edge of the tongue.

It is essential for the development of taste, that the substance to be tasted should be dissolved; and the effect is increased by friction. The larger the surface the more intense the sensation. The sensation takes some time to develop, and endures for a long time, though this may be in fact due to the stimulus remaining in contact with the terminal organs. A temperature of about 40° is the one most favourable for the production of the sensation. At temperatures much above or below this, taste is much impaired. The nerves of taste are, as we have said, the glossopharyngeal and the lingual or gustatory. The former supplies the back of the tongue, and section of it destroys taste in that region. The latter is distributed to the front of the tongue, and section of it similarly deprives the tip of the tongue of taste. There is no reason for doubting that the gustatory fibres in the glossopharyngeal are proper fibres of that nerve; but it has been urged by many, that the gustatory fibres of the lingual are derived from the chorda tympani, and that those fibres of the lingual which come from the fifth are employed exclusively in the sensations of touch and feeling.

The arguments in favour of this latter view are as follow. Cases have been observed in which the fifth nerve has been destroyed in the cranium, and yet taste in the front of the tongue has not been lost. Cases have been observed where the chorda tympani has been diseased, or injured in the tympanum, and where taste has been impaired. It is asserted that when the lingual is divided above the junction of the chorda, taste in the front of the tongue is not lost, while it disappears after section of the united lingual and chorda. It is also stated that the glossopharyngeal having been divided, and taste in consequence confined to the front part of the tongue, subsequent section of the chorda within the tympanum has removed taste altogether. On the other hand, cases have been observed where the fifth was alone diseased and yet taste was lost (in the front of the tongue); and it is moreover urged that while stimulation of the central end of a divided chorda gives rise to no sensation of taste, stimulation of an undivided chorda might give rise to such sensations by simply promoting a flow of saliva, and that division of the chorda might affect taste by interfering with the normal flow of saliva. And even if the chorda contained gustatory fibres these might have their ultimate origin in the fifth, coming from that nerve to the facial by the sphenopalatine ganglion and superficial petrosal nerve.

CHAPTER IV.

FEELING AND TOUCH.

SEC. 1. GENERAL SENSIBILITY AND TACTILE PERCEPTIONS.

WE have taken the foregoing senses first in the order of discussion on account of their being eminently specific. The eye gives us only visual sensations, the ear only auditory sensations. The sensations are produced in each case by specific stimuli; the eye is only affected by light and the ear by sound. Moreover, the information they afford us is confined to the external world; they tell us nothing about ourselves. The various visual sensations which arise in our retina are referred by us not to the retina itself, but to some real or imaginary object in the world without (including as part of the external world such portions of our own bodies as are visible to ourselves). Such also with diminishing precision is the information gained by hearing, taste and smell.

All the other afferent nerves of the body, centripetal impulses along which are able to affect our consciousness, are the means of conveying to us information concerning ourselves. The sensations, arising in them from the action of various stimuli, are referred by us to appropriate parts of our own body. When any body comes in contact with our finger, we know that it is our finger which has been touched; from the resultant sensation we not only learn the existence of certain qualities in the object touched, but we also are led to connect the cognizance of those qualities with a particular part of our own body.

Like the more specific senses previously studied, the sensations of which we are now speaking, and which may be referred to under the name of touch, using that word for the present in a wide meaning, require for their production terminal organs; and the chief but not exclusive organ of touch is to be found in the epidermis of the skin and certain underlying nervous structures. For the development of specific tactile sensations these terminal organs are as essential as are the terminal organs of the eye for sight or of the ear for hearing. Contact of the skin with a hard or with a hot body gives rise to distinct sensations, whereby we recognize that we have touched a hard or a hot body. But the application of either body or of any other stimulus to a nerve-trunk gives rise to a sensation of *general*

feeling only, corresponding to the simple sensation of light which is produced by direct stimulation of the optic nerve. We have no more *tactile perception* of a body which is in contact with a nerve-trunk than we could have *visual perception* of any luminous object, the rays proceeding from which were strong enough to excite sensory impulses when directed on to the optic nerve instead of on to the retina, supposing such a thing to be possible. It is further characteristic of these ordinary nerves of general feeling, that the sensations caused by any stimulation of them beyond a certain degree develop that state of consciousness which we are in the habit of speaking of as 'pain.' Putting aside the general feeling which many parts of the eye possess, a very strong luminous stimulation of the retina is required to produce a sensation of pain, if indeed it can be at all brought about, whereas a very moderate stimulation of the skin, and almost every stimulation of an ordinary nerve-trunk, is said by us to be painful.

The stimuli which, when applied to the skin, give rise to tactile perceptions are of two kinds only: (1) mechanical, that is, the contact of bodies with varying degrees of pressure; and (2) thermal, *i.e.* the raising or lowering of the temperature of the skin by the approach or contact of hot or cold bodies. We can judge of the weight and of the temperature of a body, because we can, through touch, perceive how much it presses when allowed to rest on our skin or how hot it is. But we can through touch derive no other perceptions and form no other judgments. An electric shock sent through the skin will give rise to a sensation, but the sensation is an indefinite one, because the electric current acts not on the terminal organs of touch, but on the fine nerve-branches of the skin. We cannot distinguish the sensation so caused from a mechanical prick of similar intensity, we cannot perceive that the sensation is caused by an electric current. Similarly certain chemical substances such as a strong acid will give rise to a sensation, but we cannot perceive the acid, we can form no judgment of its nature such as we could if we tasted it; and if the acid does not permeate the skin so as to act directly and chemically on the fine nerve-fibres, we cannot distinguish the acid from any other liquid giving rise to the same simple contact impressions. The terminal organs of the skin are such as are only affected by pressure or by temperature. Conversely pressure or variations in temperature brought to bear on a nerve-trunk, instead of on the terminal organs, produce no specific tactile sensations of pressure or temperature, but merely general sensations of feeling rapidly rising into pain.

SEC. 2. TACTILE SENSATIONS.

Sensations of Pressure.

As with visual, so with tactile and indeed with all other sensations, the intensity of the sensation maintains that general relation

to the intensity of the stimulus which we spoke of at p. 418 as being formulated under Fechner's law. We can distinguish the difference of pressure between one and two grammes as readily as we can that between ten and twenty or one hundred and two hundred.

When two sensations follow each other in the same spot at a sufficiently short interval they are fused into one; thus, if the finger be brought to bear lightly on a rotating card having a series of holes in it, the holes cease to be felt as such when they follow each other at a rapidity of about 1500 in a second. The vibrations of a cord cease to be appreciable when they reach the same rapidity. When sensations are generated at points of the skin too close together they become fused into one; but to this point we shall return presently.

The sensation caused by pressure is at its maximum soon after its beginning, and thenceforward diminishes. The more suddenly the pressure is increased, the greater the sensation; and an increase of pressure, if it be sufficiently gradual, will not give rise to any sensation. A sensation in any spot is increased by contrast with surrounding areas not subject to pressure. Thus if the finger be dipped into mercury the pressure will be felt most at the surface of the fluid; and if the finger be drawn up and down, the sensation caused will be that of a ring moving along the finger.

All parts of the skin are not equally sensitive to pressure; small differences of simple pressure are more readily appreciated when brought to bear on the palmar surface of the finger, or on the forehead, than on the arm or on the sole of the foot. In making these determinations all muscular movement should be avoided in order to eliminate the muscular sense of which we shall speak presently; and the area stimulated should be as small and the surfaces in contact as uniform as possible. In a similar manner small consecutive variations of pressure, as in counting a pulse, are more readily appreciated by certain parts of the skin than by others; and the minimum of pressure which can be felt differs in different parts. In all cases variations of pressure are more easily distinguished when they are successive than when they are simultaneous.

Sensations of Temperature.

When the temperature of the skin is raised or lowered in any spot we receive sensations of heat and cold respectively; and by these sensations of the temperature of our own skin we form judgments of the temperature of bodies in contact with it. Bodies of exactly the same temperature as our skin produce no such thermal sensations, though we can, from the very absence of sensations, form a judgment as to their temperature; and good conductors of heat appear respectively hotter and colder than bad conductors raised to the same temperature.

We may consider the skin as having at any given time and in any given spot a normal temperature at which the sensation of temperature is

at zero; for under ordinary circumstances we are not directly conscious of the temperature of our skin; it is only when the normal temperature at the spot is raised or lowered that we have a sensation of heat or cold respectively. This normal temperature may be at the same time different in different parts of the body; thus at a time when neither the forehead nor the hand are giving rise to any sensation of temperature, we may, by putting the hand to the forehead, frequently feel the former hot or cold because the normal temperatures of the two parts differ. The normal temperature in any spot may also vary from time to time. Thus when the hand is placed in a warm medium for some time, the sensation of warmth ceases; a new normal temperature is established with the zero of sensation at a higher level, a depression or elevation of this new temperature giving rise however as before to sensations of heat and cold respectively. That it is the changed condition, and not the change itself, of which we are conscious is shewn by the fact that when a portion of skin is cooled, by brief contact with a cold metal for instance, we are still conscious of the spot being cold after the cooling agent has been removed and the cooled spot is in reality being heated by the surrounding warmer tissues¹.

The change in temperature of the skin necessary to produce a sensation must have a certain rapidity; and the more gradual the change the less intense the sensation. The repeated dipping of the hand into hot water produces a greater sensation than when the hand is allowed to remain all the time in the water, though in the latter case the temperature of the skin is most affected. The same effect of contrast is seen in these sensations as in those of pressure.

We can with some accuracy distinguish variations of temperature, especially those lying near the normal temperature of the skin. These sensations, in fact, follow Fechner's law, though apparently sensations of slight cold are more vivid than those of slight heat, so that the range of most accurate sensation lies between 27° and 33°. The regions of the skin most sensitive to variations in temperature are not identical with those most sensitive to variations in pressure. Thus the cheeks, eyelids, temples and lips, are more sensitive than the hands. The least sensitive parts are the legs, and front and back of the trunk.

The simplest view which can be taken with regard to the distinction between pressure and temperature sensations is to suppose that two distinct kinds of terminal organs exist in the skin, one of which is affected only by pressure, and the other only by variations in temperature; and that the two kinds of peripheral organs are connected with different parts of the central sensory organs by separate nerve-fibres. Certain pathological cases have been quoted² as shewing not only that this is the case, but that the two sets of fibres pursue different courses in the spinal cord. Thus in certain diseases or injuries to the brain or spinal cord, hyperæsthesia as regards temperature has been observed unaccompanied by an augmentation of sensitiveness to pressure; and conversely

¹ Hering, *Wien. Sitzungsbericht*, LXXV. (1877).

² Brown-Sequard, *Journ. d. Phys.* 1863, Vol. VIII. *Archives de Phys.* 1868, Vol. I.

instances have been seen where the patient could tell when he was touched, but could not distinguish between hot and cold. Against this view it might be urged that these pathological cases have not received the critical examination which they demand; and that there are facts which shew a close dependence between the sensations of pressure and temperature. When each stimulus is brought to bear on a very limited area, the two sensations are frequently confounded, and Weber has pointed out that cold bodies feel heavier than hot bodies of the same weight. No case has yet been recorded where a hot body, a cold body, and a body of the temperature of the skin, all felt exactly alike, when each was applied with the same pressure; and the cases where a hot sponge or spoon was felt (because it was hot), and yet the sensation was confounded with one of pressure, indicate that the same terminal organs are affected by both stimuli.

With regard to the nature of the terminal organs in the skin, it may be stated that the *corpuscula tactus* were regarded by their discoverers as specific organs of touch. The end-bulbs of Krause have also been regarded in the same light. But the evidence we possess concerning this matter is at present inconclusive.

SEC. 3. TACTILE PERCEPTIONS AND JUDGMENTS.

When a body presses on any spot of our skin, or when the temperature of the skin at that spot is raised, we are not only conscious of pressure or of heat, but perceive that a particular part of our body has been touched or heated. We refer the sensations to their place of origin, and we thus by touch perceive the relations to ourselves of the body which gives rise to the tactile sensations, in the same way as in our visual perception of external objects we refer to external nature the sensations originating in certain parts of the retina. When we are touched on the finger and on the back we refer the sensations to the finger and to the back respectively, and when we are touched at two places on the same finger at the same time we refer the sensations to two points of the finger. In this way we can localize our sensations, and are thus assisted in perceiving the space relations of objects with which we come in contact.

This power of localizing pressure-sensations varies in different parts of the body. The following table from Weber gives the distance at which two points of a pair of compasses must be held apart, so that when the two points are in contact with the skin, the two consequent sensations can be localized with sufficient accuracy to be referred to two points of the body, and not confounded together as one.

Tip of tongue	1.1 mm.
Palm of last phalanx of finger			2.2 "
Palm of second "		"	4.4 "
Tip of nose	6.6 "
White part of lips	8.8 "

Back of second phalanx of finger	11·10 mm.
Skin over malar bone	15·4 „
Back of hand	29·8 „
Forearm	39·6 „
Sternum	44·0 „
Back	66·0 „

And a very similar distribution has been observed in reference to the localisation of sensations of temperature. As a general rule it may be said that the more mobile parts are those by which we can thus discriminate sensations most readily. The lighter the pressure used to give rise to the sensations, the more easily are two sensations distinguished; thus two points which, when touching lightly, appear as two, may, when firmly pressed, give rise to one sensation only. The distinction between the sensations is obscured by neighbouring sensations arising at the same time. Thus two points brought to bear within a ring of heavy metal pressing on the skin, are readily confused into one. And it need hardly be said that these tactile perceptions, like all other perceptions, are immensely increased by being exercised.

Our 'field of touch,' if we may be allowed the expression, is composed of tactile areas or units, in the same way that our field of vision is composed of visual areas or units. The tactile sensation is, like the visual sensation, a symbol to us of some external event, and we refer the sensation to its appropriate place in the field of touch. All that has been said (p. 420) concerning the subjective nature of the limits of visual areas, applies equally well, *mutatis mutandis*, to tactile areas. When two points of the compasses are felt as two distinct sensations, it is not necessary that two and only two nerve-fibres should be stimulated; all that is necessary is that the two cerebral sensation-areas should not be too completely fused together. The improvement by exercise of the sense of touch must be explained not by an increased development of the terminal organs, not by a growth of new nerve-fibres in the skin, but by a more exact limitation of the sensational areas in the brain, by the development of a resistance which limits the radiation taking place from the centres of the several areas.

By a multitude of simultaneous and consecutive tactile sensations thus converted into perceptions we are able to make ourselves acquainted with the form of external objects. We can tell by variations of pressure whether a surface is rough or smooth, plane or curved, what variations of surface a body presents, and how far it is heavy or light; and from the information thus gained we build up judgments as to the form and nature of objects, judgments however which are most intimately bound up with visual judgments, the knowledge derived by one sense correcting and completing that obtained by the other. As in other senses so in this, our sensations may mislead us and cause us to form erroneous judgments. This is well illustrated by the so-called experiment of Aristotle. It is impossible in an ordinary position of the fingers to bring the radial

side of the middle finger and the ulnar side of the ring finger to bear at the same time on a small object such as a marble. Hence when with the eyes shut we cross one finger over the other, and place a marble between them so that it touches the radial side of the one and the ulnar side of the other, we recognize that the object is such as could not under ordinary conditions be touched at the same time by these two portions of our skin, and therefore judge that we are touching not one but two marbles.

Distinct tactile sensations are, as we have seen, produced only when a stimulus is applied to a terminal organ. When sensations or affections of general sensibility other than the distinct tactile sensations are developed in the termination of a nerve, we are able, though with less exactitude, to refer the sensation to a particular part of the body. Thus when we are pricked or burnt, we can feel where the prick or burn is. When a sensory nerve-trunk is stimulated, the sensation is always referred to the peripheral terminations of the nerve. A blow on the ulnar nerve at the elbow is felt as a tingling in the little and ring fingers corresponding to the distribution of the nerve. Sensations started in the stump of an amputated limb are referred to the absent member.

Stimulation of a nerve-trunk gives rise to general sensations only; no distinct tactile perceptions can thus be produced. When cold is applied to the elbow it is felt as cold in the skin of the elbow; but a cooling of the ulnar nerve at this spot simply gives rise to pain which is referred to the ulnar side of the hand and arm.

SEC. 4. THE MUSCULAR SENSE.

When we come into contact with external bodies we are conscious not only of the pressure exerted by the object on our skin, but also of the pressure which we exert on the object. If we place the hand and arm flat on a table, we can estimate the pressure exerted by bodies resting on the palm of the hand, and so come to a conclusion as to their weights; in this case we are conscious only of the pressure exerted by the body on our skin. If however we hold the body in the hand, we not only feel the pressure of the body, but we are also aware of the muscular exertion required to support and lift the body. We are conscious of a muscular sense; and we find by experience that when we trust to this muscular sense as well as to the sensation of pressure, we can form much more accurate judgments concerning the weight of bodies than when we rely on pressure alone. When we want to tell how heavy a body is, we are not in the habit of allowing it simply to press on the hand laid flat on a table; we hold it in our hand and lift it up and down. We appeal to our muscular sense to inform us of the amount of exertion necessary to move it, and by help of that, judge of its weight. And in all the movements of our body we are conscious, even to an astonishingly

accurate degree, as is well seen in the discussions concerning vision, of the amount of the contraction to which we are putting our muscles. In some way or other we are made aware of what particular muscles or groups of muscles are being thrown into action, and to what extent that action is being carried. We are also conscious of the varying condition of our muscles, even when they are at rest; the tired and especially the paralysed limb is said to 'feel' heavy. In this way the state of our muscles largely determines our general feeling of health and vigour, of weariness, ill health and feebleness.

It has been suggested that since muscle possesses little or no general sensibility, comparatively little pain being felt for instance when muscles are cut, our muscular sense is chiefly derived from the traction of the contracting muscle on its attachments, and undoubtedly in cramp, when it can be localized, the pain is chiefly felt at the joints; and, as we know, Pacinian bodies are abundant around the joints. The investigations of Sachs, however¹, seem to shew that afferent nerves, having a different disposition from the ordinary motor nerves which terminate in end-plates, are present in muscle; and analogy would lead us to suppose that these afferent fibres, though easily excited by a muscular contraction, might possess a low general sensibility. In favour of the view that the muscular sense is peripheral and not central in origin, may be urged the fact that the sense is felt when the muscles are thrown into contraction by direct galvanic stimulation instead of by the agency of the will. Many authors, even while admitting the existence of a muscular sense of peripheral origin, contend that we also possess and are very largely guided in our movements by what might be called a 'neural' sense of central origin. That is to say, the changes in the central nervous system involved in initiating and carrying out a movement of the body, so affect our consciousness, that we have a sense of the effort itself. It has been observed that when the posterior roots are divided, movements become less orderly, as if they lacked the guidance of a muscular sense; and although the impairment of the movements may be due in part to the coincident loss of tactile sensations, it is probable that it is increased by the loss of the muscular sense. There is a malady, called locomotor ataxy, the characteristic feature of which is that, though there is no loss of direct power over the muscles, the various bodily movements are effected imperfectly and with difficulty, from want of proper co-ordination. In this disease the pathological mischief is found in the posterior columns of the spinal cord and the posterior roots of the spinal nerves, that is in distinctly afferent structures; and the phenomena seem due to inefficient co-ordination caused by the loss both of the muscular sense and of ordinary tactile sensations. The patients walk with difficulty, because they have imperfect sensations both of the condition of their muscles and of the contact of their feet with the ground. In many of their movements they have to depend largely on visual sensations; hence when their eyes are shut, they become singularly helpless.

Among the names of those who have contributed largely to our knowledge of the physiology of the various senses, the following (the more purely

¹ Reichert and Du Bois-Reymond's *Archiv*, 1874, p. 175.

physical inquirers being passed over) call for special mention. In vision, the labours of Young¹ on accommodation and colour sensations, of Purkinje² on subjective phenomena, of Donders³ and Helmholtz⁴ on the various dioptric features of the eye and the movements of the eyeballs, and of Wheatstone on binocular vision, were of first importance; and to these, on the psychological side may be added the speculations of Berkeley⁵. It need hardly be said that in his *Physiological Optics* Helmholtz has treated the whole subject in such a complete and masterly way as to make it almost entirely his own. In both sight and hearing, and indeed in the senses in general, we owe much to Johannes Müller⁶. The physiology of touch, and the relations obtaining in the senses in general between the stimulus and the sensation, was largely advanced by the labours of Weber⁷. Lastly, the researches of Helmholtz⁸ on musical sounds mark an epoch in the history of the physiology of hearing.

¹ *Phil. Trans.* 1801.

² *Beobacht. u. Versuch. zur Physiol. d. Sinne*, 1825, and other papers.

³ Numerous papers from 1846 onwards.

⁴ Numerous papers, and *Handbuch der Physiol. Optik*, 1867.

⁵ *Theory of Vision*, 1709.

⁶ *Phys. d. Gesichtssinns*, 1826, and *Handb. der Physiol.* 1835.

⁷ *De Aure*, &c. 1820. Wagner's *Handwörterbuch*, Art. *Tastsinn*.

⁸ *Tonempfindungen*, 1870.

CHAPTER V.

THE SPINAL CORD.

SEC. 1. AS A CENTRE OF REFLEX ACTION.

WE have already discussed (Book I. Chap. III.) the general features of reflex action, so that we can now confine ourselves to special points of particular interest. Since the frog and the mammal differ very markedly from each other in respect of their reflex spinal phenomena, it will be convenient to consider them separately.

In the Frog.

The salient feature of the ordinary reflex actions of the frog is their purposeful character, though every variety of movement may be witnessed, from a simple spasm to a most complex muscular manœuvre. The nature of any movement called forth is determined:

1. By the nature of the afferent impulses. Simple nervous impulses generated by the direct stimulation of afferent nerve-fibres evoke as reflex movements merely irregular spasms in a few muscles; whereas the more complicated differentiated sensory impulses generated by the application of the stimulus to the skin, give rise to large and purposeful movements. It is much more easy to produce a reflex action by a slight pressure on the skin than by even strong induction-shocks applied directly to a nerve-trunk. If, in a brainless frog, the area of skin supplied by one of the dorsal cutaneous nerves be separated by section from the rest of the skin of the back, the nerve being left attached to the piece of skin and carefully protected from injury, it will be found that slight stimuli applied to the surface of the piece of skin easily evoke reflex actions, whereas the trunk of the nerve may be stimulated with even strong currents without producing anything more than irregular movements.

In ordinary mechanical and chemical stimulation of the skin it is a series of impulses and not a single impulse which passes upwards along the sensory nerve, the changes in which may be compared to the changes in a motor nerve during tetanus. In every reflex action, in fact, the central mechanism may be looked upon as being thrown into activity through a summation of the afferent impulses reaching it¹.

¹ Cf. Stirling, *Ludwig's Arbeiten*, 1874.

When a muscle is thrown into contraction in a reflex action, the note which it gives forth does not vary with the stimulus, but is constant, being the same as that given forth by a muscle thrown into contraction by the will. From which we infer that in a reflex action the afferent impulses do not simply pass through the centre in the same way that they pass along afferent nerves, but are profoundly modified. And this explains why a reflex action takes always a considerable time, and frequently a very long time, for its development. When the toes of a brainless frog are dipped in dilute sulphuric acid, several seconds may elapse before the feet are withdrawn. Making every allowance for the time needed for the acid to develop sensory impulses in the peripheral endings of the afferent nerve, a very large fraction of the period must be taken up by the molecular actions going on in the nerve-cells. In other words, the interval between the advent at the central organ of afferent, and the exit from it of efferent impulses, is a busy time for the nerve-cells of that organ; during it many processes, of which at present we know little or nothing, are being carried on.

2. By the intensity of the stimulus. We have already pointed out (p. 90) that while the effects of a weak stimulus are limited to a few, those of a strong stimulus may spread to many efferent nerves. Granting that any particular afferent nerve is more particularly associated with certain efferent nerves than with any others, so that the reflex impulses generated by impulses entering the cord by the former, pass with the least resistance down the latter, we must evidently admit further that other efferent nerves must also, though less directly, be connected with the same afferent nerve, the passage into the second efferent nerve meeting with an increased but not insuperable resistance. When a frog is poisoned with strychnia, a slight touch on any part of the skin may cause convulsions of the whole body; that is to say, the afferent impulses passing along any single afferent nerve may give rise to the discharge of efferent impulses along any or all of the efferent nerves. This proves that a physiological if not an anatomical continuity obtains between all the nerve-cells of the spinal cord which are concerned in reflex action, that the nerve-cells with their processes form a functionally continuous protoplasmic network. This network however is marked out into tracts presenting greater or less resistance to the progress of the impulses into which afferent impulses, coming from this or that afferent nerve, are transformed on their advent at the network; and accordingly the path of any series of impulses in the network will be determined largely by the energy of the afferent impulses. And the action of strychnia is most easily explained by supposing that it reduces and equalises the normal resistance of this network, so that even weak impulses travel over all its tracks with great ease.

3. By the locality where the stimulus is applied. Pinching the folds of skin surrounding the anus of the frog produces different

effects from those witnessed when the flank or toe is pinched; and, speaking generally, the stimulation of a particular spot calls forth particular movements. From this we may infer that the protoplasmic network spoken of above is, so to speak, mapped out into nervous mechanisms by the establishment of lines of greater or less resistance, so that the disturbances in it generated by certain afferent impulses are directed into certain efferent channels. But the arrangement of these mechanisms is not a fixed and rigid one. We cannot predict exactly the nature of the movement which will result from the stimulation of any particular spot. Moreover, under a change of circumstances a movement quite different from the normal one may make its appearance. Thus when a drop of acid is placed on the right flank of a frog, the right foot is almost invariably used to rub off the acid; in this there appears nothing more than a mere 'mechanical' reflex action. If however the right leg be cut off, or the right foot be otherwise hindered from rubbing off the acid, the left foot is, under the exceptional circumstances, used for the purpose. This at first sight looks like an intelligent choice. A choice it evidently is; and were there many instances of similar choice, and were there any evidence of a variable automatism, like that of a conscious volition, being manifested by the spinal cord of the frog, we should be justified in supposing that the choice was determined by an intelligence. It is however, on the other hand, quite possible to suppose that the lines of resistance in the spinal protoplasm are so arranged as to admit of an alternative action; and seeing how few and simple are the apparent instances of choice witnessed in a brainless frog, and how absolutely devoid of spontaneity or irregular automatism is the spinal cord of the frog, this seems the more probable view¹.

It may be remarked that two entirely different questions are started by this exhibition of choice; the one is whether the spinal cord of the frog possesses intelligence, the other is whether it possesses consciousness; and care must be taken to keep the two questions apart. Intelligence in the ordinary meaning of that word undoubtedly presupposes consciousness; but we are not at liberty to say that consciousness may not exist without intelligence. It is quite possible to conceive of the simplest and most mechanical reflex action being accompanied by consciousness; the coexistence of the consciousness being merely an adjunct to, and in no appreciable way modifying the mechanical elaboration of, the act. On the other hand, though it is possible to conceive of such a concomitant and *apparently* useless consciousness, and though if we admit an evolution of consciousness we must suppose such forms of consciousness to exist, yet inasmuch as our reason for believing in the possession of consciousness by any being is based on the similarity of the acts of that being with our own behaviour, we are precluded from distinctly predicating consciousness except in the cases where an intelligence similar to our own is manifested. But the dis-

¹ Pflüger, *Die sensorische Function des Rückenmarks*, 1853. Sanders-Ezn, Ludwig's *Arbeiten*, 1867. Gergens, *Pflüger's Archiv*, XIII. (1876) p. 61.

cussion of this subject would lead us too far away from the object of the present book.

It may be added that the movements evoked by even a segment of the cord may be purposeful in character; hence we must conclude that every segment of the protoplasmic network is mapped out into mechanisms.

4. By the condition of the cord. The action of strychnia just alluded to is an instance of an apparent augmentation of reflex action best explained by supposing that the resistances in the cord are lessened. There are probably however cases in which the explosive energy of the nerve-cells is positively increased above the normal. Conversely, by various influences of a depressing character, as by various anæsthetics, reflex action may be lessened or prevented; and this again may arise either from an increase of resistance, or from a diminished action of the nerve-cells themselves. In the mammal the condition of apnoea is antagonistic, not only to the convulsions proceeding from the convulsive centre in the medulla, but also to reflex actions arising in any part of the cord, such as those produced by strychnia.

Inhibition of Reflex Action. When the brain of a frog is removed, reflex actions are developed to a much greater degree than in the entire animal. We ourselves are conscious of being able by an effort of the will to stop reflex movements, such for instance as are induced by tickling. There must therefore be in the brain some mechanism or other for preventing the normal development of the spinal reflex actions. And we learn by experiment that stimulation of certain parts of the brain has a remarkable effect on reflex action. In a frog, from which the cerebral hemispheres only have been removed, the optic thalami, optic lobes, medulla oblongata and spinal cord being left intact, a certain average time will (see p. 472) be found to elapse between the dipping of the toe into very dilute sulphuric acid, and the resulting withdrawal of the foot. If, however, the optic lobes or optic thalami be stimulated, as by putting a crystal of sodium chloride on them, it will be found on repeating the experiment while these structures are still under the influence of the stimulation, that the time intervening between the action of the acid on the toe and the withdrawal of the foot is very much prolonged. That is to say, the stimulation of the optic lobes has caused impulses to descend to the cord, which have there so interfered with the action of the nerve-cells engaged in reflex action as greatly to retard the generation of reflex impulses; in other words, the stimulation of the optic lobes has inhibited the reflex action of the cord¹.

¹ Setschenow, *Ueber die Hemmungsmechanismen für die Reflexthätigkeit des Rückenmarks*, 1863. Setschenow and Paschutin, *Neue Versuche*, 1865. Herzen, *Exp. sur les Centres modérateurs de l'action réflexe*, 1864.

We might infer from this that the increase of reflex action which appears after removal of the entire brain, is due to the absence of an inhibitory centre in the optic lobes, which in the entire frog is habitually restraining the reflex actions of the cord; but at present we require more exact evidence on this point.

If quinine¹ be injected under the skin of the back of a frog from which the cerebral hemispheres have been removed but in which the optic lobes have been left intact, the period of incubation, if we may use the phrase, of reflex action will be similarly much prolonged. If after the retardation has become clearly developed, the optic lobes be removed, the period of incubation rapidly returns to the normal. And if the quinine is similarly injected beneath the skin of a frog from which the optic lobes as well as the cerebral hemispheres have been removed, no such retardation makes its appearance. From this we may infer that the injection of the quinine inhibits the reflex actions of the spinal cord by stimulating an inhibitory mechanism in the optic lobes. It does not seem at present clear, however, whether the quinine acts directly and chemically on the optic lobes, or whether the acid solution of quinine generates in the skin under which it is injected afferent impulses which affect the optic lobes in a reflex manner. An attempt has been made to explain these results by supposing that the stimulation of the optic lobes does not bear directly on the cord, but inhibits the heart, and so by lessening the supply of blood diminishes the activity of the cord; the arguments, however, urged in support of this view are not conclusive.

Langendorf² concludes that the inhibitory action of one side of the brain is exerted on the reflex actions of the opposite side of the body, the inhibitory impulses crossing in the medulla oblongata.

Such an effect is however not confined to the optic lobes. Stimuli, if sufficiently strong, applied to any afferent nerve will inhibit, *i.e.* will retard or even wholly prevent reflex action. If the toes of one leg are dipped into dilute sulphuric acid at a time when the sciatic of the other leg is being powerfully stimulated with an interrupted current, the period of incubation will be found to be much prolonged, and in some cases the reflex withdrawal of the foot will not take place at all. And this holds good, not only in the complete absence of the optic lobes and medulla oblongata, but also when only a portion of the spinal cord, sufficient to carry out the reflex action in the usual way, is left. There can be no question here of any specific inhibitory centres, such as are supposed to exist in the optic lobes. We have already seen that the action of such nervous centres, automatic or reflex, as the respiratory and vaso-motor centres, may be either inhibited or augmented by afferent impulses. The micturition-centre in the mammal may be easily inhibited by impulses passing downward to the spinal cord from the brain, or upwards along the sciatic nerves. Goltz observed that in the case of the dog (see p. 328), micturition set up as a reflex act by simple pressure on

¹ Chapéron, Pflüger's *Archiv*, II. (1869), p. 293.

² Du Bois-Reymond's *Archiv*, 1877, p. 95.

the abdomen, or by sponging the anus, was at once stopped by sharply pinching the skin of the leg. And it is a matter of common experience that micturition may be suddenly checked by an emotion or other cerebral event. The erection centre in the lumbar cord is also susceptible of being inhibited by impulses reaching it from various sources. And though the reflex mechanism of croaking belongs to the optic lobes, and not to the spinal cord, this may be quoted in reference to the inhibition of reflex action, since the croaking which, in a frog deprived of its cerebral hemispheres, invariably follows the stroking of the flanks in a particular way, fails to appear if a sensory nerve such as the sciatic be powerfully stimulated at the same time.

In fact, to put the matter in a general way, two sensory impulses arriving at the same centre along different paths may interfere with each other, and so lessen each other's influence in producing a reflex action, or otherwise modifying the action of the centre. We have seen, in treating of the senses, that two sensory impulses may, according to circumstances, unite in producing a sensation greater than that caused by either alone, or they may lessen each other's influence, or they may have no effect on each other at all, each sensory impulse producing its effects quite independent of the other. We have moreover seen that the various automatic centres, whether sporadic or belonging to the central nervous system, may in reference to any given afferent impulse be affected in the way of inhibition or of augmentation, or may not be affected at all. Indeed we may say probably of any mass of active living protoplasm, whether automatic or reflex, whether concerned in consciousness or not, that it is so related to other parts of the body, that its activity may be diminished or exalted or unaffected by events occurring in those parts. Whether inhibition or exaltation or indifference is in any given case predominant will depend on circumstances and arrangements, the nature of which we at present understand in a very imperfect manner. And the difficulties are increased rather than diminished by presupposing the existence of an unlimited number of inhibitory and augmenting fibres.

It is worthy of notice that the inhibitory action of the optic lobes spoken of above, bears exclusively on the length of the period of incubation. We have no evidence that it diminishes the minimum intensity of stimulation required to produce a reflex action. On the other hand, the augmenting effect of strychnia is said to produce no change in the period of incubation; when a frog is poisoned with strychnia the reflex movements caused by a very slight stimulus may be very great, but the period of incubation may be the same as that of a frog in a normal condition.

In the Mammal.

In proportion as the more complex cerebral activities are developed, the need of an extensive spinal reflex activity becomes less and less. Hence we find that in the mammal the movements which are executed by the spinal cord as parts of reflex actions, are much more limited in nature, and their purposeful character is much less

evident than in the frog. Goltz and Freusberg¹ found that in the dog the reflex movements of the hind limbs executed by the lumbar cord, isolated by section from the rest of the cord, though they were to a certain extent coordinated, manifested but little purpose. Most of the reflex movements witnessed in a mammal as the result of an occasional stimulus are of an irregular disorderly kind. There is much greater resistance in the cord to the propagation of stray impulses, the ground is preoccupied by established tracts leading between the brain and the afferent and efferent nerves. It is chiefly such reflex actions as are continually being repeated, and thus form part of the ordinary labour of the cord, that exhibit a clear purpose.

Vicarious reflex movements may also be witnessed in mammals, though not to such a striking extent as in frogs. In dogs, in which partial removal of the cerebral hemispheres has apparently heightened the reflex excitability of the spinal cord, the remarkable scratching movements of the hind leg which are called forth by stimulating particular spots on the side of the body, are executed by the leg of the opposite side, when the leg of the same side is, even without any great force being applied, prevented from carrying them out². Here too the absence of a truly purposeful character of the movements is very marked, and the phenomena afford a strong support to the 'mechanical' explanation of the more complicated behaviour of the frog.

According to Owsjannikow³, if in the rabbit the spinal cord be divided at the *calamus scriptorius*, a moderate stimulus applied to the hind foot causes movements in one or other or both hind legs, but none in the fore legs, and a stimulation of the fore foot causes movements in the fore but not in the hind legs; whereas if a zone of nervous tissue only 6 to 5 mm. in height be left above the *calamus scriptorius*, stimulation of either foot may produce a movement in any part of the body. This would seem to shew that the mechanisms co-ordinating the movements of the fore limbs with those of the hind limbs, which in the frog are scattered over the whole spinal cord, are in the mammal gathered into the *medulla oblongata*. The region referred to above lies, it may be remarked, near to the 'convulsive centre' (see p. 302). Woroschiloff⁴ has observed that in the rabbit direct stimulation with an interrupted current of the cervical cord, down as far as the origin of the sixth cervical nerve, causes co-ordinated rhythmic springing movements of the body, whereas when the same stimulus is applied to lower regions of the cord, a rigid tetanus results; this too indicates the existence in the cervical cord of peculiar co-ordinating mechanisms.

Muscular movements, as parts of a reflex action, may occur on stimulation of not only the ordinary spinal and cranial sensory

¹ Pflüger's *Archiv*, viii. (1874) p. 460, ix. (1874) p. 358.

² Gergens, Pflüger's *Archiv*, xiv. (1877) p. 340.

³ Ludwig's *Arbeiten*, 1874, p. 308.

⁴ Ludwig's *Arbeiten*, 1874, p. 99.

nerves, but also of the nerves of special sense. A sound or a flash of light readily produces a start, a bright light causes many persons to sneeze, and reflex movements may even result from a taste or smell.

The Time required for Reflex Actions.

When we stimulate one of our eyelids with a sharp electrical shock, both eyelids blink. Hence, if the length of time intervening between the stimulation of the right eyelid and the movement of the left eyelid be carefully measured, this will give the time required for the development of a reflex action. Exner¹ found this to be from $\cdot 0662$ to $\cdot 0578$ sec., being less for the stronger stimulus. Deducting from these figures the time required for the passage of afferent and efferent impulses along the fifth and facial nerves to and from the medulla, and for the latent period of the muscular contraction of the orbicularis, there would remain $\cdot 0555$ to $\cdot 0471$ sec. for the time consumed in the central operations of the reflex act. The calculations, however, necessary for this reduction, it need not be said, are open to sources of error. Exner found that when he used a visual stimulus, viz. a flash of light, the time was not only exceedingly prolonged, $\cdot 2168$ sec., but very variable.

The time required for any reflex act varies, according to Rosenthal², very considerably with the strength of the stimulus employed, being less for the stronger stimuli, is greater in transverse than in longitudinal conduction, and is much increased by exhaustion of the cord. It has been stated that the central processes of a reflex action are propagated in the frog at the rate of about 8 metres a second; but this value cannot be depended on. The time thus occupied by purely reflex actions must not be confounded with the interval required for mental operations; of the latter we shall speak presently.

SEC. 2. AS A CENTRE OR GROUP OF CENTRES OF AUTOMATIC ACTION.

Irregular automatism, *i.e.* a spontaneity comparable to our own volition, is wholly absent from the spinal cord. A brainless frog placed in a condition of complete equilibrium in which no stimulus is brought to bear on it, remains perfectly motionless till it dies.

Of the various regular automatic centres, both the numerous ones in the medulla oblongata, such as the vaso-motor, respiratory, &c., and the more sparse ones in other regions of the cord, such as those connected with micturition (p. 328), defæcation (p. 234), erection, parturition, and so on, we have treated or shall have to treat of them so fully in reference to their respective mechanisms, and discussed how far they are purely automatic, or in reality merely reflex in nature, that nothing more need be said here.

¹ Pflüger's *Archiv*, viii. (1874) p. 526.

² *Monatsbericht d. Berlin. Acad.* 1873, p. 104. See also *Sitzungsbericht d. phys. med. Ges. Erlangen*, 1875, and Wundt, *Mechanik der Nerven*, &c. Abth. II. (1876).

The connection between the spinal cord and the automatic movements of the lymph hearts of the frog has also (p. 89) been briefly referred to. Volkmann¹ was the first to observe that the destruction of even a small portion of special regions of the spinal cord puts an end to the pulsations of these organs, the region or centre for the anterior pair of hearts being opposite the third vertebra, and that for the posterior pair being opposite the seventh vertebra. Eckhard² however observed that the pulsations, though ceasing upon the destruction of the regions of the spinal cord above mentioned, after a while returned; still the pulsations thus independent of the spinal cord differed in character, from being more partial and irregular than those witnessed when the spinal cord was intact. Goltz³ saw the pulsations return in about three weeks after they had been stopped by section of the tenth (coccygeal) spinal nerve, though no regeneration of the nervous tract had taken place; and he states that with care the hearts may then be wholly removed from the body without arresting their pulsations. Waldeyer⁴ though he described ganglionic cells in the neighbourhood of the hearts, found the return of pulsations after division of the coccygeal nerve or destruction of the spinal cord too inconsistent to prove their independence of the spinal cord, and Heidenhain⁵ arrived at a similar conclusion. The views expressed at p. 168 concerning the relations of peripheral and spinal vaso-motor centres may fairly be applied to these lymph hearts.

Stimulation of the coccygeal nerves with the interrupted current brings about a tetanic systole of the posterior lymph hearts, but stimulation with a strong constant current causes a stand-still in diastole⁶. Goltz⁷ found that the lymph hearts might like the blood heart be inhibited, and brought to a diastolic stand-still in a reflex manner by striking sharply the exposed intestines, and that they might also be similarly inhibited by pinching the auricles of the blood heart; the centre of this reflex inhibition appeared to be in the medulla and the afferent impulses to pass along the vagus. Suslowa⁸ traced these afferent inhibitory impulses from the intestine through the *rami communicantes*. He found that after destruction of all the posterior sensory spinal roots, the lymph hearts remained in a (diastolic) still-stand, which however gave place to a return of pulsatile activity as soon as the *rami communicantes* were also divided, the experiment in his opinion indicating that the inhibitory impulses passing along the latter channel from the intestine are of a tonic character. Suslowa also found that stimulation of a transverse section of the optic thalami or optic lobes produced a diastolic stand-still of the lymph hearts, whereas stimulation of a transverse section of the spinal cord itself increased their activity, that the inhibitory centres of Setschenow in fact govern also the lymph hearts. Priestley⁹ has in the main corroborated Suslowa's results.

¹ Müller's *Archiv*, 1844, p. 419.

² *Zt. f. rat. Med.* VIII. p. 24. and *Exp. Phys. Nerv. System*, (1866) p. 259.

³ *Cbl. f. Med. Wiss.* 1863, p. 497.

⁴ *Stud. Bresl. Inst.* III. 71.

⁵ *Disquisitiones de nervis organisque centralibus cordis cordiumve, &c.* 1864.

⁶ Eckhard, *loc. cit.* Waldeyer, *loc. cit.*

⁷ *Cbl. f. Med. Wiss.* 1863, p. 17 and 497; 1864, p. 690.

⁸ *Cbl. f. Med. Wiss.* 1867, p. 833. *Zt. f. rat. Med.* 31 (1868), p. 224.

⁹ *Studies from Phys. Lab. Owens College, 1877, Preface.*

It has been maintained that the spinal cord exercises over the skeletal muscles a tonic action comparable to that of the vaso-motor centre over the smooth muscles of the arteries. There is, however, no adequate support to this view. When a muscle is cut across in the living body, the section gapes, because all the muscles of the body are slightly stretched beyond their normal length. When one side of the face is paralysed the mouth is drawn to the opposite side, not because the paralysed muscles have lost their tone, but because there are on the paralysed side no contractions to antagonise the effect of the continually repeated contractions of the sound side. And the view is distinctly disproved by the fact that when in the living body the nerve going to a muscle is cut no permanent lengthening of the muscle is caused. After the sciatic plexus of one leg of a brainless frog has been cut, that leg hangs down more helplessly than the other when the animal is suspended. This might at first sight be considered as the result of loss of tone; but the same flaccidity is observed in a leg in which the posterior roots only of the sciatic plexus have been divided. The difference between the leg of the one side and that of the other in these cases is that the sound leg is rather more flexed than the other; and evidently this slight flexion, since it disappears on section of the posterior roots, is the result of a reflex and not of an automatic action.

SEC. 3. AS A CONDUCTOR OF AFFERENT AND EFFERENT IMPULSES.

When we move our foot, or feel something touching our foot, efferent or afferent impulses must evidently pass along the whole length of the spinal cord on their way from and to the brain. We might suppose that in such cases sensory impulses are conveyed straight along a fibre from the periphery to the sensorium, and volitional impulses straight along a fibre from the organ of the will to the muscular fibre. Or we might suppose that the conduction is not simple, but carried out by a more or less complicated system of relays. Both anatomical and physiological considerations shew that the latter view is the correct one.

The phenomena of reflex action have shewn us that the cord contains a number of more or less complicated mechanisms more or less capable of producing, as reflex results, co-ordinated movements altogether similar to those which are called forth by the will. Now it must be an economy to the body, that the will should make use of these mechanisms already present, by acting directly on their centres, rather than it should have recourse to a special apparatus of its own of a similar kind. And from an anatomical point of view, it is clear that the white matter of the upper cervical cord does not contain a sufficient number of fibres, even of attenuated dimensions, to connect the brain, by afferent or efferent ties, with every sensory or motor nerve-ending of the trunk and limbs.

Regarded in a genetic aspect, the spinal cord is a series of cemented segments, having mutual relations one with the other, and all being governed by the dominant cerebral segments. And we might fairly expect to find that in each segment of the cord part of the structures are purely segmental, and serve as a nervous centre for the afferent and efferent nerves corresponding to a portion of the body, while part are commissural structures connecting the segment with other segments, and the remainder are structures connecting the governed segment with the governing cerebral organs. Some such arrangement as this is indicated by the directions taken by the fibres of the roots of the spinal nerve; and the view is supported by the results gained by comparing sections of the spinal cord taken at different points of its length. If a curve be constructed representing the sectional area of the nerve-roots entering the spinal cord, at their respective points, along its whole length from the first cervical to the last sacral nerve, some such form as that shewn in Fig. 54 would be obtained. If instead of the sectional area of each pair of roots the continued summation of the roots were used to construct the curve, the form would be that of Fig. 55. If the variations of the sectional area of the grey matter at different points of its length were thrown into a curve, the form would be that of Fig. 56. If the variations of the sectional area of the lateral columns were taken, the curve would take the form of Fig. 57. The anterior columns similarly treated would give Fig. 58, and the posterior Fig. 59. A comparison of these several figures suggests the view that the grey matter of the cord is preeminently segmental, falling and rising as it does with the amount of nerve-fibre passing into each part of the cord, and that the lateral columns, increasing as they do from below upward, much more steadily than either the grey matter or the anterior and



FIG. 54. DIAGRAM SHEWING THE RELATIVE SECTIONAL AREAS OF THE SPINAL NERVES, AS THEY JOIN THE SPINAL CORD. (To be read from left to right.)

In this and the succeeding figures taken from Woroschiloff's paper in Ludwig's *Arbeiten*, 1874, and constructed from Stilling's data of the human spinal cord, the cervical, dorsal, lumbar, and sacral nerves are used as abscissæ; 3 mm. to the interval between each two nerve-roots. The ordinates are in millimetres, each mm. corresponding to a square unit of surface of nerve-root-section, of grey substance, or of white substance.

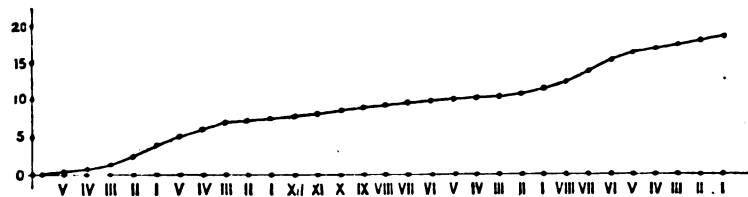

FIG. 55. DIAGRAM SHEWING THE UNITED SECTIONAL AREAS OF THE SPINAL NERVES, PROCEEDING FROM BELOW UPWARDS. The ordinates in this figure are smaller than in the preceding.

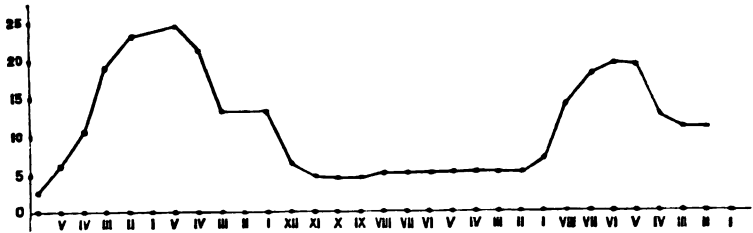

FIG. 56. DIAGRAM SHEWING THE VARIATIONS IN THE SECTIONAL AREA OF THE GREY MATTER OF THE SPINAL CORD, ALONG ITS LENGTH.

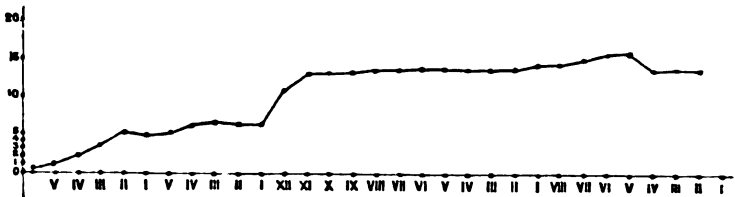

FIG. 57. DIAGRAM SHEWING THE VARIATIONS IN THE SECTIONAL AREA OF THE LATERAL COLUMNS OF THE SPINAL CORD, ALONG ITS LENGTH.

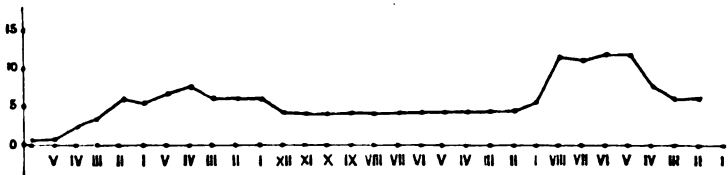

FIG. 58. DIAGRAM SHEWING THE VARIATIONS IN THE SECTIONAL AREA OF THE ANTERIOR COLUMNS OF THE SPINAL CORD, ALONG ITS LENGTH.

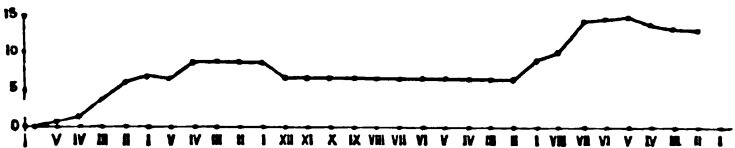

FIG. 59. DIAGRAM SHEWING THE VARIATIONS IN THE SECTIONAL AREA OF THE POSTERIOR COLUMNS OF THE SPINAL CORD, ALONG ITS LENGTH.

posterior columns, are the chief means by which the brain is brought into connection with the several segments of the cord, and thus with the nerves of the body at large.

Our information concerning the conduction of impulses along the spinal cord is derived partly from experiment and partly from pathological observation. Both these methods have their advantages and disadvantages. In experiments there is danger of confounding the immediate and temporary effects of the operation, such as those produced by shock, with the more real and lasting effects. It is difficult too in such cases to determine the existence of sensations, and to distinguish between reflex and purely voluntary movements. In pathological cases we have the advantage of being able clearly to define sensation and volition, but this is frequently more than counterbalanced by the diffuse nature of the injury or disease, and the want of exact anatomical verification. When these facts are borne in mind, it will easily be understood that in no part of physiology are the statements of investigators more conflicting and unsatisfactory.

According to the views of Brown-Séguard, and those who follow him, transverse division of the lateral half of the cord is followed on the same side, below the injury, by loss of voluntary movement, accompanied, not by loss of sensation, but by hyperæsthesia, and on the opposite side by loss of sensation without any affection of voluntary movement; whereas a longitudinal median incision through the cord causes on both sides loss of sensation in an area corresponding to the length of the incision, without any impairment of voluntary movement. That is to say, sensory impulses entering into the cord at its posterior root immediately cross to the other side of the cord and so ascend to the brain, whereas efferent impulses of volition, though they cross in the region of the medulla oblongata or higher up (and hence in cases of paralysis from cerebral mischief, the right side loses the power of voluntary movement when the left hemisphere is affected, and *vice versa*), keep to the same side of the cord along its whole length. The paths may be more accurately defined by stating that the sensory impulses pass from the posterior roots along a certain length of the posterior columns, and then cross over to the grey matter of the opposite side, in which they ascend to the brain, while volitional impulses, having crossed in the pons Varolii and medulla oblongata before their entrance into the cord, descend in the antero-lateral columns, keeping to the same side throughout, and leave the cord by the anterior roots. According to Vulpian¹, the volitional impulses are confined in the cervical region to the lateral columns, though in the dorsal and lumbar regions they travel in the anterior columns as well, and the decussation is not confined to or completed in the region of the medulla, but is continued some way down; and similarly the decussation of the sensory impulses is not sudden but gradual, so that section of a lateral half of the cord affects sensation on both sides, though most on the opposite side.

Schiff, and others with him, make a distinction between the conduction of distinct tactile sensations and that of general sensibility,

¹ *Syst. Nerv. Lec.* xvii.

as well as between the conduction of volitional impulses and that of impulses merely forming part of a reflex action. They hold that purely volitional impulses pass exclusively along the antero-lateral columns, and purely tactile sensations along the posterior columns of the same side, and that the grey matter is capable of transmitting *in all directions* such afferent impulses as only give rise to affections of general sensibility, and such efferent impulses as are parts of reflex actions. Hence, according to them, when at any part of the cord the continuity of the white matter is wholly broken, so that the parts above the injury are connected with those below by grey matter only, tactile sensations and voluntary movements are entirely absent in the parts below the injury, though violent stimulation of those parts will give rise to pain, and reflex actions in them may be induced by stimuli applied to parts above the injury. Conversely, when at any point the grey matter is destroyed but the white left intact, voluntary movements and tactile sensations remain in the parts below the injury, though even violent stimuli applied to those parts give rise to no pain, and reflex actions cannot be induced in them by stimuli applied to the parts above the seat of injury.

Schiff¹ states that when in any part of the cord the posterior columns only are left, all the rest of the white and the grey matter being removed, tactile sensations remain though no pain is felt; there is analgesia but no anæsthesia; a rabbit thus operated on is readily awaked for a moment from sleep (artificially induced by bleeding) when the hind limbs, or parts below the seat of injury, are even lightly touched, but exhibits no sign of pain when the nerves are laid bare and pinched, or when needles are driven through the skin. This experiment however, on which Schiff rests his theory of analgesia, does not prove the existence of tactile sensations; it simply shews that a peculiar condition may be brought about in which a sensory impulse produces a maximum initial result and then ceases to have any effect. The animal moved at every fresh stimulus, whether slight or strong, whether applied to the skin or to a bare nerve, but after the first explosion the central organs concerned in the matter, whatever they were, appeared to be exhausted. The condition is certainly a remarkable one, and may bear many interpretations.

To make these views logically complete, we must suppose that after section of a lateral half of the cord, tactile sensations and voluntary movements would be entirely lost on the same side below the seat of injury, but that pain would still be felt, and the parts would still be capable of being thrown into movements by reflex action.

Such are the two chief opinions held on this subject, and it must be confessed that neither is satisfactory. Much confusion has probably arisen from different kinds of animals being used, and different parts of the cord operated on, and from the want of a searching microscopic examination of the results of the various operations. These objections

¹ *Lehrb.* p. 251.

cannot be urged against the inquiries of Miescher¹ and Woroschiloff², in so far as their experiments were all conducted on rabbits, and on the same dorsal part of the cord. Miescher found the afferent impulses which, starting from the sciatic nerve and travelling up to the medullary vaso-motor centre, caused a rise in blood-pressure by acting on that centre, passed almost exclusively by the lateral columns. When one lateral column was divided, stimulation of either sciatic produced much less than the normal effect; when both columns were divided, no effect at all was produced. When only the lateral columns were left, the other parts being destroyed, the vaso-motor influences of the sciatic stimulation appeared to be quite normal. From which it would appear that afferent impulses, such as affect the vaso-motor centre, pass from one sciatic up *both* lateral columns; and Miescher came to the conclusion that they passed more on the opposite than on the same side. He also thought that impulses coming from more distant parts travelled more to the outside of the columns than those from nearer parts. It need hardly be urged that one set of experiments of this kind, the result of which can be definitely stated in millimetres of mercury, as measurements of the rise of blood-pressure, are worth a score of others, in which trust has to be placed in variable and illusory signs of sensation. On the other hand, it is obvious that the path of the afferent impulses which affect the vaso-motor centre might be quite different from that of the afferent impulses giving rise to sensations. Woroschiloff however has repeated Miescher's experiments, using the ordinary signs of sensation instead of blood-pressure, and come to the conclusion that both the afferent impulses, which, starting in the hind limbs, give rise, either by developing into sensations or by originating reflex actions, to movements in the head and fore limbs, and the efferent impulses, which, starting in the brain or upper part of the spinal cord, either by volition or as the result of stimulation, produce movements in the hind limbs, pass also exclusively through the lateral columns. The course of the afferent impulses differs however from that of the efferent impulses, in so far that the former cross over largely from one side of the cord to the other, while the latter, though they also cross, do so to a small extent only. The results of both these inquirers then lead to the conclusion, that in the dorsal spinal cord of the rabbit the lateral columns form the chief bridge between the fore and hind part of the body for the conduction of impulses of all kinds.

We must of course be cautious in inferring that what has been found to be true of the dorsal cord is also true of other parts of the cord; still the experimental results just described, when compared with the anatomical facts mentioned at p. 481, with which they wonderfully agree, enable us perhaps, to a certain extent, to interpret the observations of others in some such way as follows. In the first place, if there be any truth in our interpretation of the phenomena of strychnia poisoning, the grey matter must be physiologically continuous, and a stimulus of *sufficient strength* may cause impulses to travel in every direction along its whole length. In the second place, this protoplasmic network is marked out by barriers of resistance into nervous mechanisms for the carrying out of coordinated muscular movements and for the association of afferent impulses with these movements. In the frog these nervous mechanisms must be many and com-

¹ Ludwig's *Arbeiten*, 1870, p. 172.

² *Ibid.* 1874, p. 99.

plete; in the mammal, though they are fewer and less perfect, they exist, since the reflex movements of the mammal, though less purposeful than those of the frog, are still coordinated movements. If we suppose, as we have already urged, that volition makes use of these already existing mechanisms instead of requiring separate coordinating mechanisms in many respects exactly like them, we should expect to find that a volitional impulse, tending towards any movement, in descending from the brain, passes into the grey matter of the cord, at the spot where the appropriate mechanism exists, before it emerges in the anterior root; and conversely, that an afferent impulse passes first into the mechanism, with which it is naturally associated for the production of the frequently occurring reflex action, before it travels up to the brain by some tract more direct than the grey matter. And we should look also for similar arrangements connecting any group of nerves, not only with the brain, but with distant parts of the cord. In harmony with these functional requirements we should be prepared to find that the entrance of any large group of nerves into the spinal cord was associated with a large development of grey matter for the local coordinating mechanisms, and with a corresponding increase of certain parts of the white matter, which brought these mechanisms into connection with both the afferent and efferent nerves; but that the longitudinal connecting tracts of white matter would steadily increase from below upwards, inasmuch as a larger and larger number of mechanisms had to be connected with the brain, though the increase would not be so rapid or uniform as that of the united sectional areas of the nerves, since some part of these connecting tracts would serve to connect distant parts of the spinal cord itself. In other words, we should anticipate some such an anatomical variation of the cord, as we actually do find to be the case: the grey matter varying directly in proportion to the nerves entering into it (Figs. 54, 56), and the anterior and posterior columns following the grey matter very closely (Figs. 58, 59), while the lateral columns (Fig. 57), though not exactly parallel to the united sectional areas of the nerves (Fig. 55), steadily increase from below upwards.

In an ordinary state of things, with the cord quite intact, we should expect to find that both voluntary and sensory impulses spread into the grey matter as little as was consistent with their due propagation, and that they passed chiefly along their own side; but we can also readily imagine that when the ordinary tracts were interfered with, as after section of the white matter, powerful impulses (and these would naturally be sensory ones, since the generation of sensory but not of volitional impulses is in the hands of the experimenter, and moreover is of almost unlimited range) might spread in many directions over the grey matter. Such errant impulses would of necessity, when they reached the conscious centre, appear not as tactile, but simply as diffused, unlocalized, painful sensations. Hence it would be said that the grey matter conveyed the sensory impulses, not of touch, but of pain.

Moreover we must bear in mind that the barriers of resistance in the protoplasm of the grey matter are not wholly, even if largely structural. We have seen that the whole cord may be inhibited in reference to reflex action. This total inhibition is probably made up of individual inhibitions; and in studying the effects of section or injury of the spinal cord we must bear in mind that the change caused by the operation most probably affects

the transmission of impulses, not only negatively by breaking down accustomed tracts, but also positively by altering the action of inhibitory impulses. We have a clear instance of this in the remarkable hyperæsthesia which is a constant effect of a lateral section of the cord. Since it appears immediately after the operation, it cannot be due to any inflammatory process. Nor can it be explained as simply the result of the increased supply of blood to the peripheral terminations of the sensory nerves, caused by the section involving vaso-motor tracts; since the simple section of a vaso-motor tract, as when the cervical sympathetic is divided, does not give rise to hyperæsthesia. Nor can we explain it as due to a one-sided hyperæmia of the spinal cord itself, for we have no evidence that such a state of things is brought about. Since it lasts for a very considerable time it cannot be due to any passing exciting effect of the operation. In the frog, after hemisection of the cord below the brachial plexus, this hyperæsthesia is manifested by increased reflex movements occurring in the lower limbs as well as in the upper when the lower limbs are stimulated; and when the hemisection is converted into a complete section an hyperæsthesia still remains in both lower limbs, but it is then spoken of simply as increased reflex action, due to the isolation of the lower cord from an inhibitory centre placed higher up. In the rabbit, according to Woroschiloff, hyperæsthesia, after hemisection of the dorsal cord, manifests itself, not so much in increased reflex actions in the lower limbs as in increased movements of the upper part of the body when a stimulus is applied to the lower limbs. This may be interpreted as indicating that in the rabbit the hemisection removes inhibitory influences which previously were checking not so much the so to speak direct reflex conversion of afferent into efferent impulses, as the propagation of the afferent impulses to higher parts of the spinal cord and so upwards to the brain. We have already insisted on the probable complexity of the central processes involved in a reflex action of even the simplest kind. And of the long chain of molecular events intervening in the central (reflex) mechanism between the advent of the simple afferent impulse and the issue of the simple efferent impulses, we may, without too great a presumption, suppose that those on the so to speak afferent side of the chain might be affected by extrinsic (inhibitory or other) influences more than those on the efferent side or than those more central; and *vice versa*. Hence, adopting the view already urged, that the central mechanisms which serve for reflex actions are also the instruments of the higher cerebral operations, the afferent side of the mechanism being more especially connected with sensation, and the efferent with volition, we see the possibility of the removal of certain inhibitory influences manifesting itself especially as an apparent increase of sensibility. And this naturally would occur more readily in the rabbit, where the simpler reflex actions of the cord are so largely subordinated to the operations of the brain, than in the frog, where they still retain so much of their primitive independence. When the section passes through the whole cord instead of half, the absence of inhibition can of course only be shewn by increased reflex action in both cases. When these obscure inhibitory mechanisms have been more completely worked out, many of the at present discordant results of operations and injuries will probably be explained away.

Much discussion has arisen on the question whether the spinal

cord can be excited by stimuli applied directly to it. Undoubtedly, the cord, as a whole, is irritable; if two electrodes be plunged into it, and a current sent through the intervening tissue, muscular movements, arterial constriction, and other results, follow. But in such a case, the current falls into nerve-roots, which are as irritable, at least, as the nerve-trunks. Schiff and Van Deen maintain that the grey matter of the cord, though it will convey both motor and sensory impulses, cannot originate them. They speak of it accordingly as *kinesodic* and *æsthesodic*, as simply affording paths for motor and sensory impulses. Judging the matter *à priori*, it might be imagined that the molecular constitution of a nerve-cell as distinguished from a nerve-fibre is of such a kind that, though natural impulses pass through its protoplasm in a perfectly orderly manner, the direct application of an artificial stimulus, which, whether mechanical or electrical, must of necessity be gross in nature and rough, would produce not a series of definite impulse-waves, but rather a confused disturbance, a broken mass of waves, whose interference with each other hindered the propagation of any of them. But as a matter of fact, Miescher¹ found that after he had removed the posterior columns for a certain distance, so as to get rid of all afferent nerve-fibres, the grey matter of the stump, as tested by the effects on blood-pressure, still remained sensitive, especially to mechanical stimulation. Fick and Engelken² also found the anterior columns irritable when tested with an electrical stimulus.

¹ *Op. cit.*

² Du Bois-Reymond's *Archiv*, 1867, p. 198. Pflüger's *Archiv*, II. (1869), p. 414.

CHAPTER VI.

THE BRAIN.

SEC. 1. ON THE PHENOMENA EXHIBITED BY AN ANIMAL DEPRIVED OF ITS CEREBRAL HEMISPHERES.

A FROG from which the cerebral lobes have been removed, the optic lobes being left behind, seems to possess no volition. The apparently spontaneous movements which it executes are so few and seldom that it is much more rational to attribute those which do occur to the action of some stimulus which has escaped observation, than to suppose that they are the products of a will acting only at long intervals and in a feeble manner.

By the application however of appropriate stimuli, such an animal can be induced to perform all the movements which an entire frog is capable of executing. It can be made to swim, to leap, and to crawl. When placed on its back, it immediately regains its natural position. When placed on a board, it does not fall from the board when the latter is tilted up so as to displace the animal's centre of gravity; it crawls up the board until it gains a new position in which its centre of gravity is restored to its proper place. Its movements are exactly those of an entire frog except that they need an external stimulus to call them forth. They inevitably follow when the stimulus is applied; they come to an end when the stimulus ceases to act. By continually varying the inclination of a board on which it is placed, the frog may be made to continue crawling almost indefinitely; but directly the board is made to assume such a position that the body of the frog is in equilibrium, the crawling ceases; and if the position be not disturbed the animal will remain impassive and quiet for an almost indefinite time. When thrown into water, the creature begins at once to swim about in the most regular manner, and will continue to swim till it is exhausted, if there be nothing present on which it can come to rest. If a small piece of wood be placed on the water the frog will when it comes in contact with the wood crawl upon it, and so come to rest. If its flanks be gently stroked, it will croak; and the croaks follow so regularly and surely upon the strokes that the animal may almost be played upon like a musical instrument. Moreover, the movements of the animal are influenced by light; if it be urged to move in any particular direction, it will avoid

in its progress objects casting a strong shadow. In fact, even to a careful observer the differences between such a frog and an entire frog which was simply very stupid or very obstinate, would appear slight and unimportant except in one point, viz. that the animal without its cerebral hemispheres was obedient to every stimulus, and that each stimulus evoked an appropriate movement, whereas with the entire animal it would be impossible to predict whether any result at all, and if so what result, would follow the application of this or that stimulus. Both are machines; but the one is a machine and nothing more, the other is a machine governed and checked by a dominant volition.

Now such movements as crawling, leaping, swimming, and indeed, to a greater or less extent, all bodily movements, are carried out by means of coordinate nervous motor impulses, influenced, arranged, and governed by coincident sensory or afferent impulses. We have already seen that muscular movements are determined by the muscular sense; they are also directed by means of sensory impulses passing centripetally along the sensory nerves of the skin, the eye, the ear, and other organs. Independently of the afferent impulses, which acting as a stimulus *call forth* the movement, all manner of other afferent impulses are concerned in the generation and coordination of the resultant motor impulses. Every bodily movement such as those of which we are speaking is the work of a more or less complicated nervous mechanism, in which there are not only central and efferent, but also afferent factors. And, putting aside the question of consciousness, with which we have here no occasion to deal, it is evident that in the frog deprived of its cerebral hemispheres all these factors are present, the afferent no less than the central and the efferent. The machinery for all the necessary and usual body movements is present in all its completeness. The share therefore which the cerebral hemispheres take in executing the movements of which the entire animal is capable, is simply that of *putting this machinery into action*. The will acts after the manner of a stimulus; it might be called an intrinsic stimulus. Its operations are limited by the machinery at its command. The cerebral hemispheres by their action can only give shape to a bodily movement by selecting particular parts of the nervous machinery to be thrown into activity; and precisely the same movement may be initiated in their absence, by applying such stimuli as shall throw precisely the same parts of that machinery into the same activity.

Very marked is the contrast between a frog which, though deprived of its cerebral hemispheres, still retains the optic lobes, cerebellum and medulla oblongata, and one which possesses a spinal cord only. The latter when placed on its back makes no attempt to regain its normal position; in fact, it may be said to have completely lost its normal position; for even when placed on its feet it does not stand with its fore feet erect, as does the other animal, but lies flat on the ground. When thrown into water, instead of swimming it sinks like

a lump of lead. When pinched, or otherwise stimulated, it does not crawl or leap forwards; it simply throws out its limbs in various ways. When its flanks are stroked it does not croak; and when a board on which it is placed is inclined sufficiently to displace its centre of gravity it makes no effort to regain its balance, but falls off the board like a lifeless mass. Though, as we have seen, there is in all parts of the spinal cord of the frog a large amount of coordinating machinery, it is evident that a great deal of the more complex machinery of this kind, especially all that which has to deal with the body as a whole, and all that which is concerned with equilibrium and is specially governed by the higher senses, is seated not in the spinal cord but in the brain and medulla oblongata. We shall presently see that in the frog a great deal of this more complex machinery is concentrated in the optic lobes. The point however to which we wish now to call special attention is that the nervous machinery required for the execution, as distinguished from the origination, of bodily movements even of the most complicated kind, is present after complete removal of the cerebral hemispheres, though these movements may require the cooperation of highly differentiated afferent impulses¹.

Our knowledge of the phenomena presented by the bird or mammal from which the cerebral hemispheres have been removed is not so exact as in the case of the frog. We may however assert that volition is absent, though movements apparently spontaneous in character are more common with the mammal than with the frog, as might be expected, seeing that the more complicated brain of the former affords, even in the absence of the cerebral hemispheres, much more opportunity for the origination of stimuli within the nervous system itself, and for the play of stimuli, however originating, than does that of the latter.

When the cerebral hemispheres are removed from a bird the animal is able to maintain a completely normal posture, and that too when the corpora striata and optic thalami are taken away at the same time. It will balance itself on one leg, after the fashion of a bird which has in a natural way gone to sleep. In fact, the appearance and behaviour of a bird which has been deprived of its cerebral hemispheres are strikingly similar to those of a bird sleepy and stupid. Left alone in perfect quiet, it will remain impassive and motionless for a long, it may be for an almost indefinite time. When stirred it moves, shifts its position; and then on being left alone returns to a natural, easy posture. Placed on its side or its back it will regain its feet; thrown into the air, it flies with considerable precision for some distance before it returns to rest. It frequently tucks its head under its wings, and if by judicious feeding it has been kept alive for some time after the operation, it may be seen to clean its feathers and to pick up corn or

¹ Cf. Goltz, *Functionen d. Nervencentren des Frosches*, 1869.

to drink water presented to its beak¹. It may be induced to move not only by ordinary stimuli applied to the skin, but also by sudden sharp sounds, or flashes of light; and it is evident that its movements are to a certain extent guided by visual sensations, for in its flight it will, though imperfectly, avoid obstacles. Save that all signs of volition are absent, that all satisfactory indications of intelligence are wanting, and that the movements are on the whole clumsy, resembling rather those of a stupid drowsy bird than those of one quite wide awake, there is very little to distinguish such a bird from one in full possession of its cerebral hemispheres.

Even in a mammal, during the few hours which intervene between the removal of the hemispheres and death, very much the same phenomena may be observed. The rabbit, or rat, operated on can stand, run and leap; placed on its side or back it at once regains its feet. Left alone, it remains as motionless and impassive as a statue, save now and then when a passing impulse seems to stir it to a sudden but brief movement. Such a rabbit will remain for minutes together utterly heedless of a carrot or cabbage-leaf placed just before its nose, though if a morsel be placed in its mouth it at once begins to gnaw and eat. When stirred, it will with perfect ease and steadiness run or leap forward; and obstacles in its course are very frequently, with more or less success, avoided. It will follow by movements of the head a bright light held in front of it (provided that the optic nerves and tracts have not been injured during the operation), and starts when a shrill and loud noise is made near it. When pinched it cries, often with a long and seemingly plaintive scream. Evidently its movements are guided and may be originated by tactile, visual, and auditory *sensations*². But there is no evidence that it possesses either visual or other *perceptions*, while there is almost clear proof that the sensations it experiences give rise to no ideas. Its avoidance of objects depends not so much on the form of these as on their interference with light. No image, whether pleasant or terrible, whether of food or of an enemy, produces an effect on it, other than that of an object reflecting more or less light. And though the plaintive character of the cry which it gives forth when

¹ Bischoff and Voit, *Sitzungsberichte Acad. Wiss. München*. 1863, pp. 479, 469; 1868, p. 105.

² Here we come upon a difficulty, which we shall meet with again in the present chapter. Are we justified in speaking of 'sensation' in cases where we have reason to think that consciousness is absent, or where, as in the present instance, we have no evidence to shew whether consciousness is present or not? In treating of the senses we called attention to the fact, that we must suppose in the case, for instance, of vision, the visual peripheral organ to be connected with a visual central organ in such a way that the sensory impulses originating in the former become modified in the latter before they affect consciousness. In the peripheral organ and along the nerve of sense, the affection of the nervous tissue may be spoken of as a sensory impulse; but after the affection has traversed the central organ and become modified it is no longer a simple sensory impulse. We must then either call it a sensation irrespective of whether any change of consciousness intervenes or no, or we must give it a new name. Not wishing to introduce a new name, we have ventured to use the word 'sensation' in a sense which neither affirms nor denies the coexistence of consciousness.

pinched suggests to the observer the existence of passion, it is probable that this is a wrong interpretation of a vocal action; the cry appears plaintive simply because, in consequence of the completeness of the reflex nervous machinery and the absence of the usual restraints, it is prolonged. The animal is able to execute all its ordinary bodily movements, but in its performances nothing is ever seen to indicate the retention of an educated intelligence.

These phenomena are witnessed in some mammals at least not only after the cerebral convolutions have been removed, but also when the corpora striata and optic thalami are taken away at the same time, so that the brain is reduced to the corpora quadrigemina and cerebellum with the crura cerebri and pons Varolii. In removing the corpora striata, however, various forced movements, of which we shall speak presently, frequently make their appearance, and interfere with the observation of the phenomena we have just described; and it is stated by some observers that, even when these do not occur, the scope of the various movements of which the animal remains capable is much limited.

Vulpian insists¹ that all the phenomena above described may be observed in the total absence both of the corpora striata and optic thalami, at least in rodents. Many authors however state that dogs differ from rodents inasmuch as in dogs lesions of the corpora striata always entail loss of coordination.

With the removal of that part of the brain which lies between the hemispheres and the medulla a large number of these coordinate movements disappear. The animal can no longer balance itself, it lies helpless on its side, and though various movements of a complex character, including cries, may be produced by appropriate stimuli, they are much more limited than when these cerebral structures are intact.

We may therefore state that in the higher animals, including mammals, as in the frog, the body, after the removal of the cerebral hemispheres, is capable of executing all the ordinary movements which the animal in its natural life is wont to perform, though these movements necessitate the cooperation of various afferent impulses; and that therefore the nervous machinery for the execution of these movements lies in some part of the brain other than the cerebral hemispheres. We have reasons for thinking that it is situated in the structures forming the middle or hind brain.

SEC. 2. THE MECHANISMS OF COORDINATED MOVEMENTS.

When in a pigeon one of the horizontal membranous circular canals of the internal ear is cut through, the bird is observed to be continually moving its head from side to side. If one of the

¹ *Syst. Nerv. Lec.* xxiv.

vertical canals be cut through, the movements are up and down. The peculiar movements are not witnessed when the bird is perfectly quiet, but they make their appearance whenever it is disturbed, and attempts in any way to stir. When one side only of the head is operated on, the condition after a while passes away. When the canals of both sides have been divided, it becomes much exaggerated, and remains permanently. And it is then found that these peculiar movements of the head are associated with what appears to be a complete want of coordination of all bodily movements. If the bird be thrown into the air, it flutters and falls down in a helpless and confused manner, having apparently totally lost the power of orderly flight. If placed in a balanced position, it may remain for some time quiet, generally with its head in a peculiar posture; but directly it is disturbed, the movements which it attempts to execute are irregular and fall short of their purpose. It has great difficulty in picking up food and in drinking; and in general its behaviour very much resembles that of a person who is exceedingly dizzy.

It can hear perfectly well, and therefore the symptoms cannot be regarded as the result of any abnormal auditory sensations, such as 'a roaring' in the ears. Besides, any such stimulation of the auditory nerve as the result of the section, would speedily die away, owing to exhaustion of the nerve, whereas these phenomena may be permanent.

The movements are not due to any uncontrollable impulse; a very gentle pressure of the hand suffices to stop the movements of the head, and the hand in doing so experiences no strain. The assistance of a very slight support enables movements otherwise impossible or most difficult, to be easily executed. Thus, though when left alone the bird has great difficulty in drinking or picking up corn, if its beak be plunged into water, or into a heap of barley, it will continue to drink or eat with ease; the slight support of the water and of the grain being sufficient to steady its movements. In the same way, it can, even without assistance, clean its feathers and scratch its head, its beak and foot being in these operations guided by contact with its own body.

The symptoms manifest themselves without any injury to, or change in, the cerebellum or other parts of the brain being discoverable.

The easiest mode of explaining the phenomena is to suppose that the animal is unable, without direct contact sensations, to appreciate the position of its own head. The accompanying disorderly flight may be regarded as a secondary consequence of this, for pigeons whose heads are artificially fixed in any of the peculiar positions assumed by the heads of birds thus operated on, are said to be similarly unable to fly¹. And we may further suppose that the sense of equilibrium,

¹ Goltz, *Plüger's Archiv*, III. (1870) p. 172.

whereby the position of the head is recognised, is the product of afferent impulses originated by variations of pressure in the ampullæ of the semicircular canals, and conveyed to the brain by the auditory nerve, but not giving rise to auditory sensations. The three semicircular canals are in planes nearly at right angles to one another; hence in any given position of the head, the pressure on the different ampullæ would be different, and in any movement of the head, the ampullæ would be differently affected. A sonorous wave, on the other hand, would affect all the ampullæ equally. Our judgment concerning the position of any part of our body is determined in part by the muscular sense, by sight, touch, and by affections of general sensibility; but we may imagine that in addition to these we are continually receiving afferent impulses as it were of a new sense, from the semicircular canals, which not only determine our ideas concerning the position of our body, but also enter, without any direct effect on consciousness, into, and form a part of—an afferent factor of—the coordinating mechanism of our more complex bodily movements. There are many ways in which we could tell even with our eyes shut, whether we were standing on our heads or our feet, or how much we were inclined to the horizon; but these means would fail us when, placed perfectly flat and quiet on a horizontal rotating table, with the eyes shut, and not a muscle stirring, we attempted to ascertain how much we were turned to the right or to the left. Yet according to Crum Brown¹, we can under such circumstances pass a tolerably successful judgment as to the angle through which we are moved. If we suppose that the movement causes pressure on the ampullæ, we may out of the consequent sensations form such a judgment.

When a person under such circumstances is rotated for some time, the sense of rotation ceases to be felt; but on the rotation ceasing a sense of being rotated in the opposite direction is set up: a complementary or more strictly a rebound sensation is caused. Regarding the sensation as due to the movement of the fluid in the canals, Crum Brown supposes that the effect is different according as the flow is from the ampulla into the canal, or from the canal into the ampulla, and that thus we are able to recognise the *direction* of the rotation, whether positive or negative, *ex. gr.* to the right or to the left, and so on. Hence the existence of six ampullæ, two for each of the three axes of rotation; and Crum Brown asserts that in man and all animals which he has examined the two exterior canals of the two ears are very nearly in the same plane, and the superior canal of one ear very nearly in the same plane as the posterior canal of the other.

It is well known that when we rotate rapidly with the eyes open we feel dizzy. But no vertigo appears when we are rotated with the eyes shut, though it may appear the moment the eyes are

¹ *Journ. Anat. Phys.* 1874, p. 327; see also Mach, *Lehre v. d. Bewegungs-Empfind.* 1875; Breuer, *Wien. Med. Jahrb.* 1874, p. 72; 1876, p. 87.

opened. Vertigo in this case seems to be the result of a conflict between visual sensations and the sensations arising from this peculiar stimulation of the auditory nerve. And in the so-called Menière's disease, vertigo is associated with disease of the semicircular canals, or at least of the internal ear.

A difficulty is presented by the fact that the canals are all continuous; and hence if the effects of section are simply due to loss of fluid, and consequent absence of variations in pressure, the section of one canal ought to produce the same effect as that of all of them; but this apparently is not the case.

The injury which causes the loss of coordination need not be confined to the peripheral organs of the auditory nerve. Section of the auditory trunk produces similar effects in the mammal and the frog.

Whatever be the explanation of the exact way in which the semicircular canals exercise this influence, it is clear that afferent impulses of some sort or other do pass into the brain from these organs, and take a part in the development of the coordinating mechanism so important that changes in these impulses go far to throw the whole mechanism into disorder, or at least to impair its proper working. It is not necessary that these afferent impulses should directly affect consciousness (or, to speak more correctly, should affect that complete consciousness which is associated with volition), and so develop into distinct perceptions. We have seen that a bird from which the cerebral hemispheres have been removed is perfectly able to fly; and that therefore the coordinating nervous mechanism necessary for flight is situated in the parts of the brain lying behind the cerebral hemispheres. We have also dwelt on the fact that all the chief coordinating mechanisms of the frog lie in the hind parts of the brain; yet in the frog, as in the bird, and we may add, as in the mammal, injury to the semicircular canals produces loss of coordination whether the hemispheres be present or no. Now, we have no satisfactory reasons for either asserting or denying that what we call consciousness exists in animals deprived of their cerebral hemispheres. When signs of volition are present, we may safely take these signs as indications of consciousness also; but we are not justified in saying that all consciousness is absent when satisfactory signs of volition are wanting. We cannot form any just judgment on the matter without some more trustworthy and objective tokens of consciousness than we at present possess. But what we may safely assert is, that the coordinating mechanism, the retention of which is so striking a feature of an animal deprived of its cerebral hemispheres, is constructed out of divers afferent impulses of various kinds arriving at the coordinating centre from various parts of the body, that in fact the coordination taking place at the centre is the adjustment of efferent to afferent impulses.

Many, if not all, of these afferent impulses are such that in the presence of consciousness they would give rise to sensations and ideas; but we have no reason for thinking that the complete development of the afferent impulse into a sensation or an idea is always necessary to the carrying out of coordination. We may say that we have a sense of equilibrium by means of the semicircular canals, and when that sense is deranged, we feel giddy and cannot stand. We have no reason, however, for thinking that the failure to keep upright is due to the *feeling* of giddiness, in the sense of being a direct result of the condition of the consciousness. On the contrary, since the peculiar movements characteristic of vertigo may take place in the absence of consciousness without the vertigo being actually felt, we may with security assert that the failure to stand upright and the feeling of giddiness are both concomitant effects of the same disarrangement of the coordinating mechanism.

It cannot be too much insisted on that for every bodily movement of any complexity afferent impulses are as essential as the executive efferent impulses. Our movements, as we have already urged, are guided not only by the muscular sense, but also by contact sensations, auditory sensations, visual sensations, and visual perceptions (for the remarks made above concerning the relations of the coordinating mechanism to consciousness do not exclude the possibility of consciousness affecting the mechanism); and when we say 'they are guided,' we mean that without the sensations the movements become impossible. In studying vision we saw repeatedly that the movements of the eyes were directly dependent on vision, and every ball-room affords abundant evidence of the ties between sensations of sound and motions of the limbs. So essential, in fact, are afferent impulses to the development of complex bodily movements, that we are almost justified in considering every such movement in the light of a reflex action made up of afferent and efferent impulses and central actions, and set going by the influence of some dominant afferent impulse, or by the direct action of the will on the centre itself. All day long and every day multitudinous afferent impulses, from eye, and ear, and skin, and muscle, and other tissues and organs, are streaming into our nervous system; and did each afferent impulse issue as its correlative efferent motor impulse, our life would be a prolonged convulsion. As it is, by the checks and counter-checks of cerebral and spinal activities, all these impulses are drilled and marshalled, and kept in hand in orderly array till a movement is called for; and thus we are able to execute at will the more complex bodily manœuvres, knowing only *why*, and unconscious or but dimly conscious *how*, we carry them out.

We have ventured to use the phrase 'coordinating centre,' but it must be understood that we have no right to attach more than a general meaning to the words. We cannot, at present at least, define such a centre in the same way that we can the vaso-motor or respiratory centre. When the optic lobes as well as the cerebral hemispheres

are removed from the frog, the power of balancing itself is lost; when such a frog is thrown off its balance by inclining the plane on which it is placed, it falls down. The special coordinating mechanism for balancing must therefore in this animal be situated in the optic lobes: but after removal of these organs, the animal is still capable of a great variety of coordinate movements; unlike a frog retaining its spinal cord only, it can swim and leap, and when placed on its back immediately regains the normal position. The cerebellum of the frog is so small, and in removing it injury is so likely to be done to the underlying parts, that it becomes difficult to say how much of the coordination apparent in a frog possessing cerebellum and medulla is to be attributed to the former or to the latter; probably, however, the part played by the former is small. In the mammal, as we have stated, removal of the whole middle and hind brain does away with the most marked of these coordinating mechanisms. Removal of the pons Varolii alone has the same effect. Injury to, or disease of, the more superficial parts of the corpora quadrigemina or of the cerebellum, does not appear to influence the movements of the body at large to any striking extent; but there are many pathological cases, as well as experimental observations, tending to associate the coordinating mechanisms of which we are speaking with the deeper parts of the cerebellum. It would be hazardous, in the present state of our knowledge, to make any definite statement concerning the share taken by these several cerebral structures in the various coordinations.

The results of experiments are in many ways conflicting, but still more conflicting and still less trustworthy are the results of pathological observations. In this and in so many other parts of physiology the so-called 'experiments of nature' as seen at the bed-side, are extremely useful in suggesting and correcting experimental inquiries; but they prove broken reeds when reliance is placed on them alone. There is hardly a thesis in cerebral physiology, in respect of which a long array of 'cases' may not be quoted strikingly supporting the views enunciated, and a long array as flatly contradicting them.

Forced Movements.

All investigators who have performed experiments on the brain, have observed as the result of injury to various parts of it remarkable compulsory movements. One of the most common forms is that in which the animal rolls incessantly round the longitudinal axis of its own body. This is especially common after section of one of the crura cerebri, more particularly of the external and superior parts, or after unilateral section of the pons Varolii, but has also been witnessed after injury to the medulla oblongata and corpora quadrigemina. Sometimes the animal rotates towards and sometimes away from the side operated on. Another form is that in which the animal executes 'circus movements,' *i.e.* continually moves round and

round in a circle, sometimes towards and sometimes away from the injured side. This may be seen after several of the above-mentioned operations, but is perhaps particularly common after injuries to the corpora striata and optic thalami. There is a variety of the circus movement said to occur frequently after lesions of the nates, in which the animal moves in a circle, with the longitudinal axis of its body as a radius, and the end of its tail for a centre. And this form again may easily pass into a simply rolling movement. In yet another form the animal rotates over the transverse axis of its body, tumbles head over heels in a series of somersaults; or it may run incessantly in a straight line backwards or forwards until it is stopped by some obstacle. These latter forms of forced movements are frequently seen after injury to the corpora striata; and Nothnagel speaks of a limited portion of the grey matter of the corpus striatum as the *nodus cursorius*, the injection of chromic acid into which produces in the rabbit the straight-forward running. Lastly, many, if not all, these various forced movements may result from injuries which appear to be limited to the cerebral hemispheres.

Attempts have been made to explain the rotatory movements by reference to unilateral paralysis or to spasm of various muscles of the body caused by the cerebral injury; and in the case of the 'circus' movements with partial hemiplegia, which follow upon injury to the corpora striata or other parts, the explanation that the animal in progressing forward naturally bears on its paralysed or weak side seems a valid one; but the movements may frequently be witnessed in the complete absence of either paralysis or spasm, and cannot therefore be always so explained. On the other hand, if the views urged just now concerning the nature of the coordinating mechanisms of the brain are true, it is evident that they afford a general explanation of the phenomena, though our present knowledge will not permit us to explain the genesis of each particular kind of movement. Such gross injuries as are involved in dividing cerebral structures or in injecting corrosive substances into the midst of cerebral organs, must of necessity, either by irritation or otherwise, seriously affect the transmission not only of afferent impulses in their cerebral course, but also of central impulses, inhibitory and the like, passing from one part of the brain to another; and must therefore seriously affect the due working of the general coordinating mechanisms. The fact that an animal can, at any moment, by an effort of its own will, rotate on its axis or run straight forwards, shews that the nervous mechanism for the execution of those movements is ready at hand in the brain, waiting only to be discharged; and it is easy to conceive how such a discharge might be affected either by the substitution of some potent intrinsic afferent impulse for the will or by some misdirection of the volitional impulses. Persons who have experienced similar forced movements as the result of disease report that they are frequently accompanied, and seem to be caused, by disturbed visual or other sensations; they say they fall forward because the ground appears to sink

away beneath their feet. Without trusting too closely to the interpretations the subjects of these disorders give of their own feelings, we may at least conclude that the disorderly movements are due to a disorder of the coordinating mechanism, which in many cases is itself the result of disordered sensory impulses, and not to any paralytic or other failing of the simple muscular instruments of the nervous system. And this view is supported by the fact that many of these forced movements are accompanied by a peculiar and wholly abnormal position of the eyes, which alone might perhaps explain many of the phenomena.

SEC. 3. THE FUNCTIONS OF THE CEREBRAL CONVOLUTIONS.

All the older observers, Flourens and others, agreed that when the cerebral hemispheres were gradually removed, piece by piece or slice by slice, no obvious effects manifested themselves, either in the intelligence or volition of the animal, when the first portions only were taken away; but that, as the removal was continued, the animal became more and more dull and stupid, until at last both intelligence and volition seemed to be entirely lost. It has been frequently observed that after wounds of the skull large portions of the brains of men might be removed without any marked effect on the psychical condition of the patients. The brain when exposed was found not to be sensitive; and ordinary stimuli applied to the surface of the convolutions of animals failed in the hands of most experimenters to produce any clearly recognisable effect. Hence it became very common to deny the existence of any localization of functions in the convolutions of the hemisphere, and to speak of the brain as 'acting as a whole,' whatever that might mean. On the other hand, there was clear evidence that not only did disease of the superficial grey matter of the hemispheres cause delirium, as in meningitis, but sometimes convulsions either of an epileptic character or localized to particular groups of muscles¹. Hitzig and Fritsch² were the first to shew that the local application of the constant galvanic current to particular convolutions and to particular parts of convolutions gave rise to definite coordinate movements of various groups of muscles. Thus while the stimulation of one spot (Fig. 60) caused movements in the muscles of the neck, another caused extension with adduction of the fore leg, a third movements of the hind leg, a fourth movements of the eye and other parts of the face. In fact, they and Ferrier³, who using chiefly the interrupted or faradaic current, repeated and extended their observations, were able to map out the convolutions of the front and middle part of the hemisphere of the dog (Fig. 61), cat, monkey (Figs. 62, 63), and other animals, into

¹ Hughlings-Jackson, *Clinical and Physiol. Researches*, 1873.

² Reichert u. Du Bois-Reymond's *Archiv*, 1870, p. 300. See also Hitzig, *Das Gehirn*, Berlin, 1874.

³ *West Riding Reports*, Vol. III. 1873. See also his *Functions of the Brain*, London, 1876.



FIG. 60. THE AREAS OF THE CEREBRAL CONVOLUTIONS OF THE DOG, ACCORDING TO HITZIG AND FRITSCH.

- (1) Δ The Area for the muscles of the neck.
- (2) + " " extension and adduction of the fore limb.
- (3) x " " flexion and rotation of the fore limb.
- (4) # " " hind limb.

Running transversely towards and separating (1) and (2) from (3) and (4) is seen the *crucial sulcus*.

- (5) ⊙ The facial Area.

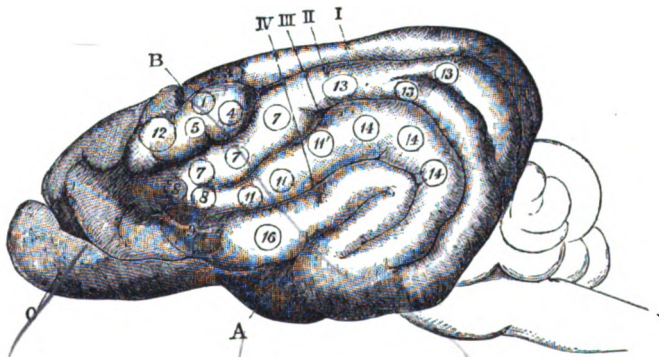

FIG. 61. THE AREAS OF THE CEREBRAL CONVOLUTIONS OF THE DOG, ACCORDING TO FERRIER.

O. The Olfactory Lobe. A. The Fissure of Sylvius. B. The Crucial Sulcus.

Faradaic stimulations of the areas indicated by the several circles produce the following results.

- (1) The hind leg is advanced as in walking.
- (3)¹ Lateral or wagging motion of the tail.
- (4) Retraction and adduction of the opposite fore limb.
- (5) Elevation of the shoulder of, and extension forwards of the opposite fore limb.

¹ There is in the dog no movement comparable to that resulting from stimulating (2) (Figs. 62, 63) in the monkey. (Ferrier.)

- (7) Closure of the opposite eye caused by combined action of the orbicular and zygomatic muscles.
 (8) Retraction and elevation of the opposite angle of the mouth.
 (9)¹ The mouth is opened and the tongue moved, sometimes barking is produced.
 (11) Retraction of the angle of the mouth.
 (12) Opening of the eyes and dilation of the pupils; the eyes and then the head turning to the opposite side.
 (13) The eyeballs move to the opposite side.
 (14) Pricking or sudden retraction of the opposite ear.
 (15) Torsion of the nostril on the same side.
 (16) Elevation of the lip and dilation of the nostril (?).

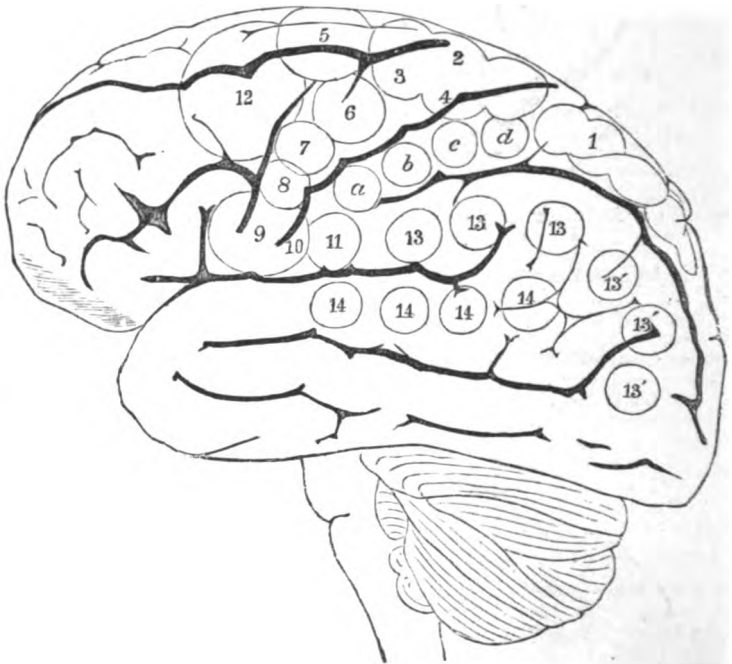

FIG. 62.

FIGS. 62, AND 63. SIDE AND UPPER VIEWS OF THE BRAIN OF MAN, WITH THE AREAS OF THE CEREBRAL CONVOLUTIONS, ACCORDING TO FERRIER.

The figures are constructed by marking on the brain of man, in their respective situations, the areas of the brain of the monkey as determined by experiment, and the description of the effects of stimulating the various areas refers to the brain of the monkey.

- (1) (On the postero-parietal [superior parietal] lobule). Advance of the opposite hind limb as in walking.
 (2), (3), (4) (Around the upper extremity of the fissure of Rolando). Complex movements of the opposite leg and arm, and of the trunk, as in swimming.
 (a), (b), (c), (d). (On the postero-parietal [posterior central] convolution). Individual and combined movements of the fingers and wrist of the opposite hand. Prehensile movements.
 (5) (At the posterior extremity of the superior frontal convolution). Extension forward of the opposite arm and hand.

¹ Corresponding to (9) and (10) in the monkey.

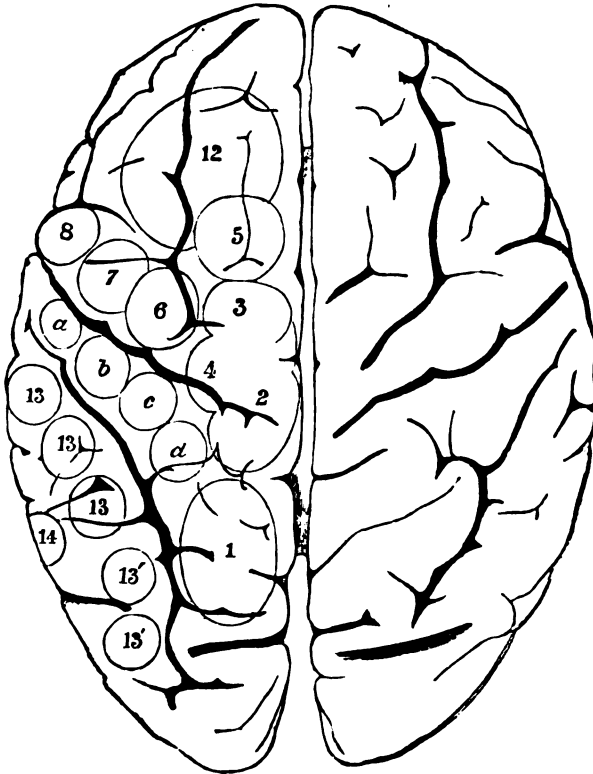

FIG. 63.

- (6) (On the upper part of the antero-parietal or ascending frontal [anterior central] convolution). Supination and flexion of the opposite forearm.
- (7) (On the median portion of the same convolution). Retraction and elevation of the opposite angle of the mouth by means of the zygomatic muscles.
- (8) (Lower down on the same convolution). Elevation of the ala nasi and upper lip with depression of the lower lip, on the opposite side.
- (9), (10) (At the inferior extremity of the same convolution, Broca's convolution). Opening of the mouth with (9) protrusion and (10) retraction of the tongue. *Region of Aphasia. Bilateral action.*
- (11) (Between (10) and the inferior extremity of the postero-parietal convolution). Retraction of the opposite angle of the mouth, the head turned slightly to one side.
- (12) (On the posterior portions of the superior and middle frontal convolutions). The eyes open widely, the pupils dilate, and the head and eyes turn towards the opposite side.
- (13), (13') (On the supra-marginal lobule and angular gyrus). The eyes move towards the opposite side with an upward (13) or downward (13') deviation. The pupils generally contracted. (*Centre of vision.*)
- (14) (On the infra-marginal or superior [first] temporo-sphenoidal convolution). Pricking of the opposite ear, the head and eyes turn to the opposite side, and the pupils dilate largely. (*Centre of hearing.*)

Ferrier moreover places the centres of taste and smell at the extremity of the temporo-sphenoidal lobe, and that of touch in the gyrus uncinatus and hippocampus major.

a number of precisely limited areas, the stimulation of each area producing a distinct and limited movement, while stimulation of a large surface produced general convulsions. The movements were so precise that they answered each to the spot stimulated almost as completely as a note answers to a key struck on the piano.

A relationship has also been observed between the brain surface and the secretion of saliva, the beat of the heart, the condition of the pupil, the action of vaso-motor nerves, and other organic functions. Eulenburg and Landois¹ find that extirpation of the motor areas for the extremities causes a rise of temperature (lasting in some cases for months) in the corresponding limbs; and Hitzig had previously observed the same thing. Balogh² describes in the dog and rabbit, areas in the cerebral surface stimulation of which causes acceleration of the heart's beat, and other areas stimulation of which slows the heart. Bochefontaine³ observed that stimulation of the cerebral surface in the neighbourhood of the crucial sulcus produced a rise of arterial pressure with alternating acceleration and retardation of the heart's beat. Among other results of stimulating the same and other regions of the surface he witnessed increased flow of saliva, contraction of the spleen, bladder, uterus, &c., and dilation of the pupil; the last effect might follow upon stimulation of almost any point of the cerebral surface. But on these points the results of various observers are by no means constant⁴. Hæmorrhage into the lung has been observed in the rabbit to follow upon stimulation of the cerebral surface⁵.

These experiments leave no doubt that there is a connection between galvanic stimulation of the brain surface and bodily movements; but the exact nature of this connection is at present very obscure. One thing may be at least affirmed, that these cerebral spots are not motor centres in the sense that the coordination of the movements takes place in them; for we have seen that the most complete coordination obtains in the total absence of the cerebral hemispheres. If there is any real connection between the movements and the grey matter of the convolutions, it must be because the latter has direct relations with the coordinating mechanisms placed lower down in the brain.

It seems *a priori* unlikely that such valuable material as we must needs suppose the grey matter of the convolutions to be, should be taken up in such, so to speak, menial work as bending or straightening a limb; and the results of subsequent observers have largely diminished the value which was at first attached to Hitzig's observations. Not only do the phenomena continue when the animal is under opium and chloroform, provided that the anæsthesia is not too profound, and not only do they require for their development currents of a considerable strength, mechanical and chemical

¹ Virchow's *Archiv*, 68 (1876), p. 245.

² Hofmann and Schwalbe's *Bericht*, 1876, p. 38.

³ *Archives de Physiol.* III. (1876) p. 140.

⁴ Brown-Séquard, *Archives de Phys.* II. (1875) p. 854. Eckhard, *Beiträge*, VII. (1876) 199.

⁵ Nothnagel, *Cbl. Med. Wiss.* 1874, p. 209.

stimulation being unable to produce them, but the results of stimulation are the same, when the surface of the convolution operated on is highly congested, and even when it has become completely dried up, or after it has been washed with strong nitric acid. The results, moreover, remain unchanged when the area experimented upon is isolated from the surrounding grey matter, by plunging a cork-borer for some distance into the brain round it; and even when the brain substance is removed to some depth down by means of the cork-borer, and the electrodes plunged into the blood which fills up the vacant cylindrical hole¹. They remain the same when the surface stimulated is disconnected physiologically though not physically from the deeper parts, by a horizontal incision carried some little distance from the surface². And though the area, stimulation of which gives rise to a definite movement, is always limited, yet it is not constant in different individuals, and frequently a large and deep sulcus may be seen running through its very midst³. All these facts suggest that the results are due to the escape of the current from the surface to which the electrodes are applied to deeper underlying portions of the brain, the escape taking place along definite lines determined by the electrical conductivity of the brain substance. And Burdon Sanderson⁴ states that local stimulation of the white matter immediately surrounding a corpus striatum produces localized movements quite similar to those caused by stimulation of the corresponding cerebral surface; from which it may be inferred that when the surface appears to be stimulated, it is really the corpus striatum which is affected physiologically by the stimulus. Albertoni and Michieli⁵ however found that several weeks after the removal of an area stimulation of the scar or its immediate neighbourhood no longer produces the particular movements characteristic of the area. Unless it can be shewn that the injury in such cases produces marked changes in the electrical conductivity of the brain substance, this observation may be taken as indicating that the fibres passing downwards from the area to deeper parts of the brain, have through degeneration become incapable of conveying the impulses set going by the application of the current to the brain surface; that the connection between the area and the deeper parts is not a physical one, depending on the escape of the current, but a physiological one, dependent on the existence of fibres passing from the area to some more central mechanism and capable of producing their special effects when stimulated in any part of their course.

At all events, these various experiments shew very clearly that the fact of certain movements following upon stimulation of certain areas, is no proof that those areas are to be considered as motor centres. They are not fundamentally inconsistent with the hypothesis that such centres exist; for the fibres proceeding from the centres to the corpus striatum or to other organs, might, when artificially stimulated, produce the same effect as when they were the channels of impulses originating in the centres in a normal manner, just as cardiac inhibition may be brought about by artificial stimulation of the vagus, though in ordinary life it occurs through

¹ Hermann, Pflüger's *Archiv*, x. (1875) 77. Braun, Eckhard's *Beiträge*, vii. (1874) 127.

² Burdon Sanderson, *Proc. Roy. Soc.* xxii. (1875) 368.

³ Hermann, *op. cit.*

⁴ *Op. cit.*

⁵ Hofmann and Schwalbe's *Bericht*, 1876, p. 80.

the activity of the medullary cardio-inhibitory centre. They are not inconsistent with the hypothesis, but they afford it very little support.

On the other hand, if these circumscribed areas of superficial grey matter were, as they have by some been supposed to be, motor centres in the sense of being necessary for the initiation of voluntary movements corresponding to those produced by artificial stimulation, particular sets of voluntary movements ought to disappear when the particular areas are removed by incision, or rendered functionally incapable by chromic acid injection or otherwise.

On this point however the various observers disagree. Ferrier¹ states that removal of the convolution or area stimulation of which according to him causes movements of the eyeballs and a turning of the head, brings about total blindness of the opposite eye; and he is accordingly led to the conclusion that the area in question is 'a sensory centre,' a 'visual centre,' and that the movements following upon stimulation of it are simply the results of an excitation of visual sensations. He similarly finds an 'auditory centre,' the removal of which causes deafness, a 'tactile centre,' and centres for taste and smell. Other areas he regards as 'motor' centres, and states that their removal produces localized paralysis without impairment either of general sensation or of any of the special senses. Hitzig on the other hand is inclined to interpret the imperfect movements which make their appearance as due to a loss of muscular sense or 'muscular consciousness;' and Nothnagel², who injected minute quantities of chromic acid into limited areas of the cerebral surface, observed motorial anomalies, which he also was inclined to regard as due to a loss or impairment of the muscular sense. Nothnagel however made the important observation that the symptoms after a while disappeared; and in this he has been corroborated by subsequent observers. Ferrier appears to have kept his animals alive for a few days only at the utmost, and to have ceased his observations before any such recovery had taken place. Hermann³ removed from dogs cerebral areas, stimulation of which gave localized movements, and found that the paralysis and loss of sensation which immediately followed the operation, after some days wholly disappeared. Carville and Duret⁴ obtained the same results, and they shewed that the restitution of power could not be due to a vicarious action of the same centre of the other hemisphere, since after recovery from a left-sided paralysis due to an operation on the right hemisphere, subsequent operation on the same centre of the left hemisphere produced the usual effect on the right side, but did not cause a return of the paralysis on the left side. They could only reconcile their results with the 'motor centre' theory by supposing that when a centre was destroyed, other portions of the same hemisphere took up its functions. But the most serious objections to the theory of superficial cerebral centres in any of the forms in which it has as yet been brought forward, are furnished by the recent observations by Goltz⁵ on dogs. He removed parts of the cerebral surface by washing the nervous substance away with a stream of water, a method which has the advantage of causing comparatively little bleeding, and affording considerable localization of the injury; and he

¹ *Op. cit.*

² Virchow's *Archiv*, Bd. 57 (1873), p. 184.

³ *Op. cit.*

⁴ *Archives de Physiol.* II. (1875) p. 352.

⁵ Pfüger's *Archiv*, XIII. (1876) p. 1, XIV. (1877) p. 412.

found that the operation was followed at first by diminished sensation and voluntary power on the opposite side of the body; imperfect sight or even blindness of one eye being also a constant result. Flourens and other inquirers had previously observed a special connection between sight and the cerebral convolutions. These effects, however, were temporary only, and eventually the animal appeared to recover completely; so much so that upon a hasty examination the animal seemed perfectly normal. Goltz insists most strongly that both the paralysis of voluntary movement and the diminution of cutaneous sensibility, as well as the imperfection of sight, occurred *whatever part of the brain were removed*. They were witnessed when portions of the posterior lobe, which, according to Hitzig and Ferrier, contains no motor centres, were removed; the partial blindness came on whether Ferrier's visual centre were taken away or not. Both the amount of mischief done, and the speed and completeness with which recovery took place, depended not on the locality operated on, but, as older observers found, on the quantity of brain substance removed. After recovery from one operation, a second removal of brain substance reproduced the same phenomena as the previous one; and, though at first sight this might be taken as supporting Carville and Duret's theory of a vicarious action of other parts of the same hemisphere, the impossibility of such a view is proved by the fact that Goltz was able to remove the greater part of the grey matter of one hemisphere, and yet recovery, except in the points to be mentioned directly, eventually took place. Goltz argues that all the temporary phenomena are due to the superficial lesions exercising inhibitory influences on the parts of the brain lying between the cerebral convolutions and the spinal cord. He very aptly compares the paralysis caused by operations on the surface of the cerebrum to the paralysis of the lumbar spinal centres which results from and lasts some time after division of the spinal cord in the dorsal region. When the injury had been extensive the recovery was very slow, and was obviously hastened by educational exercise. The dog gradually learnt to regain the power of which the operation for a time had deprived him. Nevertheless, in spite of apparently complete recovery, careful observation shewed that for weeks after a considerable portion of the cerebral surface had been removed, certain things remained permanently lacking. The sight was always impaired in such a way that, though the animal could see sufficiently to guide his movements, distinct scenes ceased to have any effect on him. A dog which before the operation became violently excited when the laboratory servant dressed in a fantastic garb was presented to him, was not in the least affected by the same after the operation, at a time when he seemed otherwise to have completely recovered. He had, we might almost say, visual sensations, but visual perceptions were either absent or very dim. Again, a dog which had been trained to give his left paw into his master's hand, never regained the power to do this after portions of the right hemisphere had been removed; when asked, he gave the right paw, and when the left was insisted on he crossed over the right paw to the left side. He knew what was wanted, but there was a break in the nervous machinery connecting the intellectual volition with the coordinate motor impulses necessary for raising the left paw. He could, however, lift the left paw for the purpose of walking, when the same or very similar impulses were set going from another quarter. It should be added, however, that in cases where a small

amount of the cerebral substance had been removed, this power of 'giving the paw' was regained; and it is of course possible that in all cases, the restitution both of movements and of sight would in the end have become complete if the animals had lived for months instead of weeks after the operation.

Besides the experimental evidence just discussed we have also striking pathological proof of the connection of certain movements with a particular convolution. The condition known as aphasia, using that word in its general sense, including its several varieties, as meaning the loss of articulate speech, is so often associated with disease of the posterior portion of the third frontal convolution Fig. 62 (9) (10), that it becomes impossible not to admit that there must be *some* causal connection between this part of the brain and speech. In the vast majority of cases the disease is on the left side of the brain and occurs in company with right hemiplegia, but cases have been recorded where the right side of the brain was affected.

Seeing that articulate speech is a thing learned by use, it has been suggested that in most persons one side of the brain only has been educated for this purpose, and hence that one side only of the brain is employed; that we are in fact left-brained in respect to speech in the same way that we are right-handed in respect to many bodily movements; and this view is apparently supported by the fact that the left side of the brain is on the whole larger and more convoluted than the right side¹; but the question of the dual action of the two cerebral hemispheres is too dark a subject to enter into here.

It is obvious that loss of speech may arise from a variety of causes. It may be due to simple paralysis of the hypoglossal, and other nerves concerned in speech. It may be occasioned by an imperfection in the coordinating mechanism by which the efferent impulses are marshalled just previous to their exit from the central nervous system. Or it may be caused by a break in the nervous chain connecting the idea of the word with this coordinated motor mechanism of expression. Lastly, the fault may lie in the generation of the idea itself. It is the two latter forms of aphasia which appear to be connected with the cerebral convolution spoken of above. The cases are strikingly parallel to that of the dog just mentioned.

¹ This statement by Gratiolet has however been opposed by Ecker and others; but cf. Boyd (*Phil. Trans.* 1861, p. 261).

SEC. 4. THE FUNCTIONS OF OTHER PARTS OF THE BRAIN.

Although much has been written, and many experiments performed, in reference to the various parts of the brain, the views which have thereby been worked out are for the most part neither satisfactory nor consistent; indeed, the proper method to study the brain is probably to trace out a cerebral operation along its chain of events rather than to seek to attach readily definable functions to the cerebral anatomical components.

A fundamental difficulty meets us at the threshold of every inquiry into the particular function of any part of the brain. When an organ, such for instance as the corpus striatum, is removed by the knife, or placed *hors de combat*, or thrown into an abnormal condition, by the injection of corrosive fluids, or by a hæmorrhage, or by other pathological changes, we have no right to infer that the negative phenomena, loss of volition, loss of sensation, &c., which make their appearance, prove that in its normal condition the organ in question is a seat or a main tract of volition, of sensation, &c. This may be the explanation of the experiment or malady; but it may not. Whatever may prove in the end to be the nature of nervous inhibition, it is clear that inhibitory actions are important factors in the production of nervous phenomena; they are so prominent in the spinal cord, that we may be sure they play a distinguished part in cerebral operations. But if this be so, the removal of an organ may, by the withdrawal of an accustomed check, put an end to the working of a machinery, with which it is otherwise only indirectly connected; and, conversely, unusual inhibitory impulses or inhibitory impulses of unusual intensity, started in an organ by the presence of a blood-clot, or by other pathological changes, may be sufficient to stop the progress of events in some quite distant parts of the brain. We have already referred to Goltz's explanation of the temporary paralysis resulting from injuries to the cerebral surface, that it was due not to the mere loss of the piece of brain taken away, but to the fact of the removal acting in some way or other on the rest of the nervous system, in a manner which we cannot at present define more closely than by calling it inhibitory. In the case of the dog (p. 328) whose dorsal cord was divided, pinching the skin of the leg or lower part of the body inhibited the reflex act of micturition. There can be no doubt that if amputation of the leg were performed on such a dog, micturition would become impossible for several days at least. In such an instance there would be no difficulty in distinguishing between 'loss of micturition' due to destruction of the lumbar cord and that due to amputation of the leg; but the difficulties of cerebral physiology are such that we might be led in speaking of the brain to make a statement which would have a parallel in the assertion that the leg was 'the seat of reflex micturition.' Difficulties such as these are far more likely to occur in cases of disease than in those of operative interference; and it is this which renders caution so necessary in the physiological handling of clinical facts. For instance, because right hemiplegia has been at times observed in cases of disease apparently limited to the right corpus striatum, it does not follow that the generally admitted connection, of which we shall speak directly,

between each corpus striatum and the opposite side of the body, is unfounded¹.

We may therefore be permitted to summarise very briefly what is actually known.

Corpora Striata and Optic Thalami.

The preceding discussions enable us to lay down two broad propositions: (1) The functions of the cerebral convolutions are eminently psychical in nature; these parts of the brain intervene, and as far as we can judge, intervene only, in the operations of the nervous system as intellectual and volitional factors. (2) The hinder parts of the brain, viz. the corpora quadrigemina, crura cerebri, pons Varolii, cerebellum, and medulla oblongata, are capable by themselves of carrying into execution complex movements, the coordination of which implies very considerable elaboration of afferent impulses; they can do this even in the case of such mammals as the rabbit and the rat, in the total absence of the cerebral hemispheres, corpora striata, and optic thalami. These two latter bodies, often spoken of as 'the basal ganglia,' are undoubtedly the great means of communication between the cerebral hemispheres on the one hand and the crura cerebri on the other. Though some fibres² do pass from the crura by or through the ganglia to the cerebral convolutions without being connected with the nerve-cells of those ganglia, the great mass of the peduncular fibres are probably connected with the superficial grey matter of the hemispheres in an indirect manner only, the lower or anterior fibres (*crusta*) passing first into the corpora striata, and the upper or posterior fibres (*tegmentum*) into the optic thalami. This anatomical disposition would lead us to suppose that these bodies have important functions in mediating between the psychical operations of the cerebral convolutions on the one hand, and the sensori-motor machinery of the middle and hind brain on the other; and the separate courses taken by the peduncular fibres would further lead us to expect that the functions of the corpora striata differ fundamentally from those of the optic thalami.

When in the human subject a lesion occurs involving both these bodies, on one side of the brain, the result is a loss of sensation in, and voluntary power over, the opposite side of the body and face, a so-called hemiplegia, which may be absolutely complete without any impairment whatever of the intellectual faculties. The will and the power to receive impressions are present in their entirety, but neither efferent nor afferent impulses can make their way to or from the peripheral organs and the cerebral convolutions. The injury to the basal ganglia blocks the way. In

¹ Cf. Brown-Séquard, *Archives de Physiol.* iv. (1877) p. 409 et seq.

² Quain's *Anatomy*, 8th ed. II. 555.

the great majority of cases, the anæsthesia (or loss of sensation) and akinesia (or loss of movement) are absolutely confined to the opposite side of the body; and the cases in which a lesion of the basal ganglia of one side of the brain affects the same side of the body or both sides, must be regarded as exceptional, and explicable as the results of the action of one side of the brain on the other side of the brain or at least of some part of the nervous system. The results of experiments on animals agree entirely with the general experience of pathologists, that lesions of the corpora striata and optic thalami produce their effect on the opposite side of the body. Whatever be the view taken concerning the decussation of sensory and motor impulses in the spinal cord, it must be admitted that both kinds of impulses cross over completely somewhere during their transmission to and from the basal ganglia and the peripheral organs.

When however we have admitted that these bodies act, as it were, the part of middlemen between the cerebral convolutions and the rest of the brain, we have gone almost as far as facts will support us. We are not at present in a position to state dogmatically what is the nature of the mediation which either body respectively effects. A very tempting hypothesis is one which suggests that the corpora striata are concerned in the downward transmission and elaboration of efferent volitional impulses, and the optic thalami in a similar upward transmission and elaboration of afferent sensory impulses; and there are many facts which may be urged in favour of this view, which was first developed and expounded by Carpenter and Todd. So much acceptance indeed has it found, that many pathologists regard it as established, and speak confidently of the corpora striata as motor and the optic thalami as sensory ganglia. A careful review however of all the facts leads to the conclusion that this division of functions has not yet been clearly proved.

The pathological evidence in this case, were it sharply defined and accordant, would be of unusual value; but it is neither the one nor the other. A number of cases indeed may be cited to shew not only that lesions of a corpus striatum may be accompanied by akinesia without anæsthesia, but that lesions of an optic thalamus may cause anæsthesia without actual akinesia, that is without any further interference with the execution of voluntary movements than is occasioned by the loss of the coordinating sensations. Of these two classes of cases, the latter is the more valuable, since all clinical experience shews that any lesion more readily interferes with volitional movements than with the reception of sensory impressions. Convulsions are not common when the lesions are confined to these bodies; but when witnessed they can generally be referred to the corpora striata rather than to the optic thalami; like the paralysis, the convulsions are generally limited to the opposite side of the body, though feeble movements may occasionally be seen on the same side as well. On the other hand, numerous cases have been recorded where an injury apparently confined to one corpus striatum has had as part of its results anæsthesia of the opposite side of the body; and others

where disease apparently confined to an optic thalamus has caused loss of movement as well as of sensation.

Experiments on animals, though very valuable as regards the investigation of movements, are imperfect means of studying the phenomena of conscious sensations. We have already seen that crude unelaborated sensations may originate in an animal deprived of its cerebral hemispheres; and it becomes a matter of great difficulty to disentangle the evidences of these primitive sensations from those of the higher psychical perceptions. Moreover we do not, at present, at all know to what an extent the larger development of the cerebral hemispheres in man has influenced the ordinary functions of the other parts of the brain. It may be that important functions which in the rabbit belong to the middle and hind brain have, in man, almost disappeared in order to make these structures more useful servants of the cerebral hemispheres. It may be, however, that the greater activity of the convolutions has simply increased the ordinary labours of the middle and hind brain. We cannot at present say which effect has resulted; but meanwhile great caution ought to be exercised in drawing inferences from experiments on a rabbit, or on a dog, as to what are the functions of the corresponding parts of the human brain.

Ferrier¹ observed that when the corpora striata were stimulated with an interrupted current, convulsive movements of the opposite side of the body took place; the animal, when the stimulus was powerful, being thrown into complete pleurosthotonus, the side of the body opposite to the side of the brain stimulated being forcibly drawn into an arch. The localized movements observed by Burdon Sanderson (p. 505) were lost in the general convulsions caused by the galvanic current affecting a large portion of the organ. When, on the other hand, the optic thalami were similarly stimulated, no such convulsions were observed. On this point Carville and Duret's² observations are in accordance with those of Ferrier; and the results, as far as they go, appear at first sight to be in accordance with the theory of the exclusively motor functions of the corpora striata, and the exclusively sensory functions of the optic thalami. But it would obviously be rash to draw any such conclusion directly from them, since, if the optic thalamus is concerned in the transmission and elaboration of sensory impulses, the application of the galvanic current to it ought, by discharging a number of sensory impulses, to give rise to movements of some kind or other, and not to be characterized by the absence of all effects. Moreover any such inference is opposed by the results of Nothnagel's³ experiments. This observer destroyed by injection of chromic acid both *nuclei lenticulares* (the extra-ventricular portions of the corpora striata) of the rabbit, with the result of bringing the animal almost exactly into the same condition as if both its cerebral hemispheres had been removed. When, on the other hand, by the help of a special instrument, he succeeded in destroying both optic thalami without any other injury to the brain, no obvious effects followed; there were no signs of either loss of volition or of sensation, nothing in fact could be noticed except a rather peculiar disposition of the limbs. When the *nuclei lenticulares*

¹ *Op. cit.*

² *Op. cit.*

³ *Op. cit. Ibid.* Bd. 58 (1873), p. 420; Bd. 60 (1874), p. 129; Bd. 62 (1875), p. 201.

were destroyed there was no apparent loss of sensation, that is to say the animal readily moved when stimulated by pinching the skin, &c.; but it was impossible to tell whether sensory impulses reached the cerebral convolutions, since no manifestations whatever of the condition of the convolutions were possible. The animal might have felt acutely, and yet have been unable, from the loss of the appropriate motor tracts, to express itself; or it might have been as incapable of the higher psychical feeling as it was of executing spontaneous movements. The phenomena resulting from destruction of the nuclei lenticulares admit of no clear proof in either direction. The fact, however, that voluntary movements continued as usual after complete destruction of the optic thalami, goes far to prove, that in the rabbit at least, these bodies are not the only means by which sensory impulses pass to the cerebral convolutions. Even admitting (as indeed in the case of man we must do, seeing that the general anæsthesia following upon lesions of the corpora striata, or optic thalami, is not necessarily accompanied by blindness or loss of any other special sense) that the specific impulses of vision and the other senses still reached the rabbit's convolutions; yet the initiation, and hence the general character of the animal's movements, must have been influenced by the total absence of all psychical tactile sensations, though, in consequence of the coordinating mechanisms of the hinder brain being still intact, their coordination might still have been carried out. Apparently however this was not the case: the movements did not in any way betray the loss of any factors.

Lussana and Lemoigne¹, who regard the optic thalami as motor centres for the lateral movements of the *anterior* limbs (a lesion of one optic thalamus paralysing the adduction of the forelimb of the corresponding and the abduction of that of the opposite side), saw no evidence of any loss of general sensibility or signs of pain to result from injuries to these bodies, and no movements to result from stimulation of other than their deep parts. After a lesion however of the optic thalamus of one side they invariably found blindness in the opposite eye.

Carville and Duret² found that in the dog section of the internal capsule, or expansion of fibres passing between the nucleus lenticularis and optic thalamus, in the anterior part of its course where it passes between the nucleus lenticularis and the nucleus caudatus, led to hemiplegic loss of voluntary movement on the opposite side, though stimulation of the paralysed limb still gave rise to reflex movements. When the section was carried through the posterior part of the expansion, between the nucleus lenticularis and optic thalamus, the loss of voluntary movement on the opposite side of the body was accompanied by loss of sensation, *i.e.* when the paralysed limbs were pinched, no responsive reflex movements followed. It is hazardous, however, to draw from these experiments any positive conclusions.

Nothnagel³ observed that in the rabbit voluntary movements still persisted after destruction of both nuclei caudati; in this respect these portions of the corpora striata presented a marked contrast to the nuclei lenticulares. Nevertheless destruction of one nucleus caudatus

¹ *Fisiologia del centri nervosi encefalici*, 1871, and *Archives de Physiologie*, iv. (1877) p. 119 et seq.

² *Op. cit.*

³ *Op. cit.*

frequently induced a certain amount of paralysis of the opposite side of the body, which disappeared after removal of the nucleus caudatus of the other side; and as we have already stated, destruction or injury to a particular part of the nucleus caudatus, viz. the so-called nodus cursorius, gave rise to remarkable forced movements, which made their appearance even after the previous removal of the nuclei lenticulares. The injection of chromic acid into other parts of the nucleus caudatus also frequently caused for a while forced movements, either straight forward, or of the circus kind, which differed from those witnessed by older observers in operations on the corpora striata after removal of the hemispheres, inasmuch as they were executed by an animal still possessing intelligence, and frequently striving to avoid obstacles.

It is impossible at present to give a satisfactory explanation of all these varied and frequently inconstant phenomena, but it may be worth while to return again to the possibility of considering some at least of the phenomena as inhibitory effects. The fact that the paralysis, curvature of the body, and the circus movements resulting from lesion to one nucleus caudatus or nucleus lenticularis, disappear when the same body on the other side is removed, warns us against too hastily assuming that a loss or diminution of voluntary power means nothing more than a break in the transmission of volitional impulses; it may mean that, but it may mean also the development of nervous actions having inhibitory effects. In the experiment of Carville and Duret quoted above, pinching the left hind limb after section of the right internal capsule produced no reflex action whatever. Now it is absurd to suppose that in this case the reflex centre was removed, or any part of a veritable reflex chain broken, because, as we know, pinching the hind limb will produce a reflex movement, provided only a portion of the lumbar cord be left intact and functional. There must in this case have been inhibition of the lumbar reflex centres; and if of these, why not of many other reflex and other centres as well? Especially in pathological cases does it become a matter of serious importance to inquire how far the varied phenomena of akinesic and anæsthetic paralysis are due to the positive influences of inhibitory agencies, and not the merely negative results of a break in the nervous chain.

Corpora Quadrigemina.

We have already seen that the centre of coordination for the movements of the eyeballs (p. 443) and that for the contraction of the pupil (p. 406), lie in the nates or anterior tubercles of the corpora quadrigemina. These two centres are associated together in such a way that when the eyeballs are directed inwards and downwards, as for near vision, the pupils are at the same time contracted, and when the eyeballs are directed upwards, and return to parallelism, the pupils are dilated to a corresponding extent. When the eyeballs are moved sideways the pupils remain unchanged¹. This is the case when the movements of the eyeballs are brought about by direct stimulation of various parts of the nates; hence the associa-

¹ Adamuk, *Cbt. med. Wiss.* 1870, p. 65.

tion of the movements of the pupil and the ocular muscles is determined by the structural relations of their respective centres, and is not simply psychical in its nature.

Knoll¹, in opposition to Flourens, Budge and others, maintains that removal of the corpora quadrigemina in rabbits does not do away with the reflex contraction of the pupil, unless the optic tract be injured at the same time; and from that infers that the centre of the pupillary contraction is not situate in the nates. He does not however state where the centre is placed, and his results are in contradiction with the later ones of Adamuk. Adamuk affirms that, while stimulation of the anterior tubercles simply causes movements in the eyeballs with associated pupillary changes, stimulation of the posterior tubercles or testes, especially in the middle, causes dilation of the pupil with a peculiar starting of the eyes, which however maintain their parallelism. Knoll had observed the same dilation, and found that it ceased to appear after section of the sympathetic in the neck; according to him, however, the effect is produced by stimulating the nates, and is most marked on the same side.

Flourens observed that unilateral extirpation of the corpora quadrigemina in mammals or of the optic lobes in birds produced blindness in the opposite eye; and the same result has been gained by all subsequent observers². We have seen moreover that both frogs, birds, and mammals continue to receive and react upon visual impressions after the total removal of the cerebral hemispheres. From these facts we infer that visual sensory impulses become transformed into visual sensations in the corpora quadrigemina; or, in other words, that these nervous structures are centres of sight. But they are so in a limited sense only. We have seen that destruction or injury of the cerebral hemispheres profoundly affects vision. In the absence of the cerebral convolutions, a crude vision, devoid of distinct visual perceptions, is probably all that is possible. Vision in fact, beginning in the retina, is partially elaborated in the corpora quadrigemina and possibly in the optic thalami³, but does not become completely developed until the cerebral convolutions have been called into operation.

Since unilateral destruction of the corpora quadrigemina entails blindness of the opposite eye, and apparently does not affect at all the visual sensory impulses originating in the eye of the same side, it is obvious that a complete decussation of the sensory impulses must take place before the centre is reached. In man, the generally accepted opinion teaches that the decussation of the optic fibres in the chiasma though large is not complete, and hence that some crossing must take place in the brain. Biesiadecki⁴, however, states that in the rabbit the decussation in the chiasma is complete, and Mandelstamm⁵ affirms the same for man. Attempts have been made to

¹ Eckhard's *Beiträge*, iv. (1869) p. 109.

² McKendrick, *Trans. Roy. Soc. Ed.*, 1873.

³ Lussana and Lemoigne, *op. cit.*

⁴ Moleschott's *Untersuch.* viii. (1862) 156.

⁵ *Cbt. med. Wiss.* 1873, p. 339.

explain the curious phenomena of hemiopia, in which portions of the retinae of the two eyes are insensible to light, by reference to morbid changes affecting particular parts of the chiasma, according to the variety of the hemiopia; but it is possible, if not probable, that the cause is sometimes situate in the brain itself.

Flourens and subsequent observers noticed that injury or removal of the corpora quadrigemina on one side frequently caused forced movements, and that removal of the whole mass led to great want of coordination. These results are quite in harmony with the fact mentioned above concerning the coordinating functions of the optic lobes in frogs. But at present we have no exact knowledge concerning the nature of the coordination, and what relations are borne in this respect by the corpora quadrigemina to the cerebellum, crura cerebri, and pons Varolii.

Flourens in many cases entirely removed the corpora bigemina from birds without any incoordination or disturbance of movements resulting, though they were seen by McKendrick in pigeons and by Ferrier in rabbits and monkeys. It has been urged however by many (Schiff) that when such phenomena do occur after removal of the corpora quadrigemina, they are the result of coincident injury to the underlying crura cerebri. Adamuk¹ observed in rabbits that galvanic stimulation of the posterior tubercles, in contrast to the anterior tubercles, produced movements of the animal, though Knoll observed no such effect. Ferrier² saw various movements follow upon stimulation of the surface of the corpora quadrigemina with the interrupted current. Flourens found that while mechanical stimulation of the surface of these bodies produced no effect, deep puncture caused various movements, which he attributed to stimulation of the crura cerebri beneath. This suggests that the movements caused by galvanic stimulation are due to escape of current, and we here meet with the same difficulty that was experienced in dealing with the cerebral convolutions. Ferrier states that with even a moderately strong current the movements may be so violent as to merge into a general opisthotonus. He also observed that stimulation of the posterior tubercles was followed by marked and distinct cries, affording a curious parallel to the croaking produced by reflex stimulation in frogs, the seat of which is in the optic lobes. Lussana and Lemoigne³ also observed a cry invariably to follow upon section of the corpora quadrigemina and superior peduncles of the cerebellum (processus cerebelli ad testes), though no loss of sensibility could be detected as resulting from the operation. These observers assert that section of the superior peduncles paralyses the muscles of the trunk of the opposite side and thus leads to the vertebral column being arched towards the same side, and to 'circus' movements. According to Valentin, Budge, and others, stimulation of the corpora quadrigemina, or of the optic lobes, produces movements in the œsophagus, stomach, and other parts of the alimentary canal, and in the urinary bladder. In such cases the stimulation must have an indirect effect on the centres of the above movements, which, as we have seen, are situate in the medulla and lumbar

¹ *Op. cit.*² *Op. cit.*³ *Op. cit.*

cord respectively. Danilewsky, junr.¹ and Ferrier have observed changes in the blood-pressure and respiration follow upon stimulation of the corpora quadrigemina, as of other parts of the brain.

Cerebellum.

We have already referred to the cerebellum as being probably concerned in the coordination of movements. Flourens observed that when a small portion of the cerebellum was removed from a pigeon, the animal's gait became unsteady, when larger portions were taken away its movements became much more disorderly, and when the whole of the organ was removed an almost total loss of coordination supervened. Other observers have obtained similar results in other animals; and it has in general been found that lateral or unsymmetrical lesions and incisions produce a greater effect than those which are median or symmetrical. Section of the middle peduncle on one side almost invariably gives rise to a forced movement, the animal rapidly rolling round its own longitudinal axis; the rotation is generally though not always towards the side operated on; and is accompanied by nystagmus, *i.e.* by peculiar rolling movements of the eyes suggestive of vertigo; frequently one eye is moved in one direction, *e.g.* inwards and downwards, and the other in a different or opposite direction, *e.g.* outwards and upwards. The clinical evidence is discordant, for though unsteadiness of gait has been frequently witnessed in cases of cerebellar disease, many histories have been recorded in which extensive disease, amounting at times to almost complete destruction, of the cerebellum has existed without any obvious disturbance of the coordination of movements. Still the experimental evidence is so strong, that we must consider the cerebellum as an important organ of coordination, though we are unable at present to define its functions more exactly. It is probable, but not proved, that its functions are especially connected with the afferent impulses proceeding from the semicircular canals.

Observers are not agreed as to how far the loss of coordination which follows upon lesion or removal of part of the cerebellum is temporary or permanent. Flourens found that, when the portion removed was small, the disorderly movements which at first appeared eventually vanished, but when a large portion was removed the loss of coordination became permanent. These results are capable of interpretation on the view that the coordinating mechanism is situated in the deeper structures, and hence, while completely removed by the deeper incisions, are only temporarily paralysed by the shock of the slighter operations. Hitzig and Ferrier find that injury to or removal of the lateral lobe produces the same forced movements as section of the middle peduncle. Flourens and others have observed that, while lateral injury gave rise to lateral movements, injury to the anterior or posterior median portions caused the animal to fall forwards and backwards respectively. Nothnagel² has been led from his experiments

¹ Pflüger's *Archiv*, xi. (1875) 128.

² Virchow's *Archiv*, Bd. 68, (1876) p. 33.

on rabbits to the conclusion that the lesions which determine a loss of coordination are those which result in a solution of continuity between the two sides of the organ, the loss of even an entire half having, according to him, no such effect. Ferrier finds that stimulation of the cerebellar surface by the interrupted current causes in monkeys, dogs, and cats, movements of both eyes with associated movements of the head and limbs, and to a certain extent of the pupils. The eyes moved horizontally or vertically or obliquely, symmetrically or unsymmetrically, with or without rotation, according as the electrodes were applied to one or other portion of the surface. In fact the results were to a certain extent similar to those obtained by Adamuk on stimulating the corpora quadrigemina, but they cannot be wholly explained as simply due to escape of current, if, as Hitzig¹ asserts, very similar phenomena may be witnessed, not only with weaker currents, but even on mechanical stimulation.

Nothnagel² also finds that mechanical stimulation of even the surface of the cerebellum gives rise, without signs of pain being felt, to movements chiefly of the trunk and extremities and of those muscles which are governed by the facial, hypoglossal, and fifth nerves. These movements, which are developed somewhat slowly, manifest themselves first on the side operated on, and then ceasing on that side make their appearance on the opposite side.

Purkinje observed long ago, that when a constant current of sufficient strength was sent through the head from ear to ear, a feeling of giddiness was experienced; external objects appearing to rotate in the direction of the current, from right to left for instance when the anode was placed at the right ear, while at the same time the subject himself leant from the left towards the right. Hitzig³ has more fully investigated and described the phenomena. When the current is sufficiently strong, remarkable movements of the eyes are seen to take place on the current being made; these are varied, and partake somewhat of the nature of nystagmus. They consist of a rapid snatching movement in the direction of the current, and a slower return in the contrary direction, the eyes oscillating between the two. Sometimes the two eyes move together, sometimes they are dissociated. That neither the feeling of vertigo nor the movements of the body are dependent on abnormal visual sensations caused by the ocular movements, is shewn by the fact that they occur when the eyes are shut, and also in blind people; and indeed the feeling of vertigo may be induced by a current too feeble to cause any abnormal movements of the eyeballs. The application of the current when the eyes are shut gives rise to a sensation similar to that of sitting or standing in a carriage which is being turned over in the direction of the current, from right to left when the anode is placed at the right ear. When the current is broken, there is rebound of the phenomena in an opposite direction. The person now leans towards the kathode, and external objects seem to revolve from the kathode to the anode. All these phenomena are best explained by supposing that the current interferes with the cerebral coordinating mechanism, from which result, as efferent effects, the compensating movements of the body and of the eyes, the change in the mechanism at the same time so affecting consciousness as to produce a feeling of vertigo. Whether they are due to an anelectrotonic and katelectrotonic condition of the ampullar fibres of the respective auditory nerves, or are caused by the

¹ *Op. cit.*

² *Op. cit.*

³ *Op. cit.*

action of the current on cerebellar or other structures, must be left for the present undecided.

Attempts have been made to connect the cerebellum with the sexual functions; but there is no satisfactory evidence of any such relation. As we shall see later on, the nervous centres connected with the sexual and generative organs are seated, in the case of dogs at least and probably of all animals, in the lumbar spinal cord; and all or nearly all sexual phenomena may be witnessed in animals, the lumbar spinal cords of which have been isolated by section from the rest of the cerebro-spinal system. Galvanic stimulation of the cerebellum produces no change in the generative organs, and when erection of the penis is caused by emotions, the tract connecting the cerebral convolutions with the erection-centre in the spinal cord passes straight along the *crura cerebri* and medulla, for Eckhard¹ has observed that stimulation of these parts in the dog will produce erection.

Eckhard has brought forward facts to shew that lesions of certain parts of the cerebellum, like those of certain parts of the medulla oblongata, cause either diabetes or simple hydruria.

According to Budge, stimulation of the cerebellum produces peristaltic movements in the œsophagus and stomach; and Schiff observed inflammation of the intestine with hæmorrhage after lesions of the peduncles of the cerebellum.

Crura Cerebri and Pons Varolii.

Though from the grey matter abundant in both these organs we may infer that they possess important functions, we hardly know more concerning them than that the former serve as the great means of communication between the spinal cord and the higher parts of the brain, and that both are intimately connected with the coordination of movements, since either forced or disorderly movements are the frequent results of section of either of them; and as we have seen, the possession of these parts, in the absence of the cerebral hemispheres, and even of the corpora striata and optic thalami, is sufficient to carry out the most complex bodily movements.

Since the paralysis of the face seen in cases of hemiplegia from disease of the corpus striatum is on the same side as that of the body, it follows that the impulses proceeding along the cranial nerves cross over like those of the spinal nerves. Hence when paralysis of the face occurs on the opposite side to that of the body, it may be inferred that the injury or disease has affected the cranial nerve (or nerves) in a part of its course before decussation has taken place; and pathological observations support this view, unilateral disease or injury of the pons Varolii not unfrequently involving the facial nerve of the same side in its comparatively superficial course, and so causing

¹ *Beiträge*, VII. (1873) 67.

paralysis of the muscles of the same side of the face as the disease, and the opposite side to the paralysis of the limbs. It is probable that the decussation which we have seen to begin in the spinal cord, is gradually completed as the impulses pass through the medulla and pons Varolii. Against the view of those who maintain that volitional impulses cross suddenly and completely at the decussation of the pyramids, may be urged the fact that a longitudinal section through the decussation does not entail loss of voluntary movements on both sides of the body, as it ought to do if the volitional impulses crossed completely at this spot. Moreover, according to Vulpian, the loss of voluntary movement which follows upon a unilateral section of the medulla is not confined entirely to one side of the body.

Medulla Oblongata.

We have so often spoken of this link between the brain and the spinal cord, that it is hardly necessary here to do more than recall the fact, that the majority of the 'centres' for various organic functions are situated in it.

These we may briefly recapitulate as follows: 1. The respiratory centre (p. 289), with its neighbouring convulsive centre (p. 302). It may here be remarked that just as venous blood readily excites the convulsive centre, but will not otherwise produce convulsions, so certain poisons may produce tetanus by acting on the convulsive centre alone. Such a poison is picrotoxine; in the absence of the medulla it causes no tetanic spasms, in this respect differing markedly from strychnia. 2. The vaso-motor centre (p. 158). 3. The cardio-inhibitory centre (p. 147). 4. The diabetic centre, or centre for the production of artificial diabetes (p. 337). 5. The centre for deglutition (p. 227). 6. The centre for the movements of the œsophagus and stomach (p. 231), with its allied vomiting centre (p. 237). 7. The centre for reflex excitation of the secretion of the saliva (p. 206), with which may be associated the centre through which the vagus influences the secretion of pancreatic juice (p. 216), and possibly of the other digestive juices. 8. The centre for the dilation of the pupil by means of the cervical sympathetic.

In the frog, as we have urged, p. 490, the medulla is undoubtedly largely concerned in the coordination of movements, and it is exceedingly probable that in the mammal a considerable portion of work of this kind falls to its lot.

In conclusion, we may call attention to the fact, that of the whole brain certain parts respond easily, by various movements in different parts of the body, to mechanical or other stimuli applied directly to them, while others will not. The former are consequently spoken of as sensitive, and together form what has been called an excito-motor centre; they are the (deep parts of) the corpora quadrigemina, the crura cerebri, the pons Varolii, the (deep parts of) the cerebellum, and the medulla. The latter are spoken of as insensitive;

they are the cerebral hemispheres including the corpora striata and optic thalami (and the superficial portions of the cerebellum (?) and corpora quadrigemina). In view of the results obtained by electrical stimulation of the cerebral convolutions and other parts, this distinction cannot however be regarded as important.

SEC. 5. ON THE RAPIDITY OF CEREBRAL OPERATIONS.

We have already seen (p. 478) that a considerable time is taken up in a purely reflex act, such as that of winking, though this is perhaps the most rapid form of reflex movement. When the movement which is executed in response to a stimulus involves mental operations a still longer time is needed; and the interval between the application of the stimulus and the commencement of the muscular contraction varies according to the nature of the mental labour involved.

The simplest case is that in which a person makes a signal immediately that he perceives a stimulus, *ex. gr.* closes or opens a galvanic circuit the moment that he feels an induction shock applied to the skin, or sees a flash of light, or hears a sound. By arrangements similar to those employed in measuring the velocity of nervous impulses, the moment of the application of the stimulus and the moment of the making of the signal are both recorded on the same travelling surface, and the interval between them is carefully measured. This interval, which has been called by Exner 'the reaction period,' consists of three portions; (1) the passage of afferent impulses from the peripheral sensory organ to the central nervous system, including the generation of the impulses in the sensory organ, (2) the transformation by psychical operations of the afferent into efferent impulses, and (3) the passage of the efferent impulses to the muscles, including the latent period of the muscular contractions. If the time required for the first and third of these events be deducted from the whole, the 'reduced reaction period' as it may be called, gives the time taken up exclusively by the operations going on in the central nervous system.

The reaction period, both reduced and unreduced, varies according to the nature and disposition of the peripheral organs stimulated. The reaction period of vision has long been known to astronomers. It was early found that when two observers were watching the appearance of the same star, a considerable discrepancy existed between their respective reaction periods; and the difference, which varied from time to time according to the personal conditions of the observers, was called 'the personal equation.' Thus the personal equation between the celebrated astronomers Struve and Bessel varied between the years 1814 and 1834 from .04 to 1.02 sec., the reaction period of Struve being so much longer than that of Bessel. These figures, however, are not to be compared with those which will be given immediately, inasmuch as several complications were introduced by the method of observation.

Exner¹ has carefully determined the reaction period of himself and others with different stimuli, and under various circumstances. When the stimulus was an induction shock thrown into the skin of the left hand, the

¹ Pflüger's *Archiv*, vii. (1873) p. 601.

signal being made with the right hand, the reaction period varied from ·1337 sec. in Exner himself to ·3576, or even to ·9952, in an obtuse individual. When the stimulus was applied in different ways, the signal always being made with the right hand, the results in Exner's own case were as follows :

Direct electrical stimulation of the retina	·1139
Electric shock on the left hand	·1283
Sudden noise.....	·1360
Electric shock on the forehead	·1374
" " on the right hand.....	·1390
Visual impression from an electric spark	·1506
Electric shock on the toe of the left foot	·1749

Hence tactile sensations produced by the stimulus of an electrical shock applied to the skin are followed by a shorter reaction period than the auditory sensations ; but the period of these is in turn shorter than that of visual sensations produced by luminous objects, though the shortest period is that of visual sensations produced by direct electrical stimulation of the retina. Hirsch had previously arrived at similar results, and Donders' had similarly determined the reaction period or physiological time, as he termed it, to be, roughly speaking, for feeling $\frac{1}{4}$ th, for hearing $\frac{1}{4}$ th, and for sight $\frac{1}{4}$ th of a second. Von Wittich³ found the reaction period to be ·167 sec., when the application of a constant current to the tongue produced a gustatory sensation. Vintschgau and Hönigschmied⁴ determined the reaction period of taste to be for salines ·1598 sec., for sugar ·1639, acids ·1676, and quinine ·2351. Even with the same stimulus, the reaction period will vary according to the condition of the individual. Exner found that while strong tea had no obvious effect, two glasses of Rhine wine lengthened the period from ·1904 to ·2969.

The calculations involved in 'reducing' the reaction period are obviously open to much error ; Exner's own reduced period was ·0828, that of the obtuse individual quoted above ·3050 and ·9426 ; that is to say, an intelligent person takes less than $\frac{1}{10}$ of a second to perceive and to will. If the whole reaction period of the case when the retina was directly stimulated be deducted from the period of the case when a luminous object was used to create visual impressions, the difference (·0367 sec.) would indicate the latent period of luminous stimulation of the retina ; but it is doubtful whether any great dependence can be placed on such a calculation.

In all the above instances a single stimulus was used, and all that the person experimented on had to do was to perceive the stimulus, and to make an effort in accordance. If, however, the stimulus, instead of being applied to a part of the body determined by previous arrangement, as for instance to the left foot, were applied either to the left or the right foot, without the person being told which it was to be, and it was arranged that he should make a signal when the left foot, but not when the right foot was stimulated, additional mental exertions would be necessary ; and Donders⁴ found that in such a case the reaction period was considerably prolonged. The following table gives the difference between a simple reaction period, and one in which a mental decision has to

¹ Reichert and Du Bois-Reymond's *Archiv*, 1868, p. 657.

² *Zt. Rat. Med.* (3) xxxi. p. 113.

³ Pfüger's *Archiv*, x. (1875) p. 1.

⁴ *Op. cit.*

be carried out before the voluntary effort to make the signal is initiated, *i. e.* gives the time required for the person to 'make up his mind' in accordance with the nature of the sensation which he receives; this it will be seen is, roughly speaking, from $\frac{1}{5}$ to $\frac{1}{20}$ th of a second.

Dilemma between two spots of the skin, right and left foot stimulated by an induction shock	·066
Dilemma of visual sensations between two colours, suddenly presented to the view: signal to be made on seeing one but not on seeing the other	·184
Dilemma between two letters: signal to be made on seeing one only	·166
Dilemma between five letters: signal to be made on seeing one only	·170
Dilemma of auditory sensations: two vowels suddenly sung: signal to be made on hearing one only	·056
Dilemma between five vowels: signal to be made on hearing one only	·088

SEC. 6. THE CRANIAL NERVES.

Though we have incidentally dwelt on the functions of all these nerves, it may be as well to recapitulate them in a tabular form.

1. *Olfactory.* Nerve of smell.

2. *Optic.* Nerve of sight.

3. *Oculo-motor.* Motor nerve to the levator palpebræ superioris and all the muscles of the eye, except the obliquus superior and the external rectus. Efferent nerve for the contraction of the pupil and for the muscles of accommodation. Hence when the nerve is divided or otherwise paralysed the upper eyelid falls (ptosis); the eye, which is turned outwards, is capable of partial movements only, viz. such as can be produced by the rectus externus and obliquus superior; when the head is moved, the eye moves with it, the inferior oblique not being able to execute the usual compensating movements of the eyeball; the pupil is dilated, and the eye cannot accommodate for near distances.

The root of the nerve shews recurrent sensibility, due to fibres from the fifth, but is otherwise a purely motor nerve¹.

4. *Trochlear or Pathetic.* Motor nerve to the obliquus superior. When the nerve is paralysed, no marked difference is observed in the position of the eye, but the patient sees double when he attempts to look straight forward or towards the paralysed side; the images however coalesce when he turns his head to the sound side. When the head is moved from side to side the eye moves with it, the usual compensating movement of the eye which accompanies the movements of the head failing in consequence of the superior oblique not acting.

It is a purely motor nerve, but receives recurrent fibres from the fifth.

¹ Schiff, *Lehrb.* p. 376.

5. *Trigeminus*. A mixed efferent and afferent nerve, with distinct motor and sensory roots, the latter bearing the ganglion of Gasser.

Efferent Fibres. Motor fibres to the muscles of mastication, temporal, masseter, two pterygoids (mylo-hyoid, anterior belly of digastric) and buccinator, to the tensor palati, and tensor tympani; vaso-motor fibres to various parts of the head and face; secretory fibres to the lachrymal gland, and according to some authors to the parotid and submaxillary glands by fibres joining the facial. Trophic (?) fibres to eye, nose, and other parts of face, see p. 381. Efferent fibres for the dilation of the pupil, see p. 408.

Afferent Fibres. General nerve of sensation of the skin of head and face, and of the mucous membrane of the mouth, except the back part of the tongue, the posterior pillars of the fauces, and a large part of the pharynx, these parts being supplied by the glosso-pharyngeal and vagus; the back of the head is chiefly supplied by branches from the cranial nerves, and the external meatus and concha are supplied chiefly by the auricular branch of the vagus. Nerve of special sense of taste for the front part of the tongue, see p. 461.

6. *Abducens*. Motor nerve to the rectus externus. When the nerve is divided or otherwise paralysed, the eye is turned inwards.

The abducens is joined by fibres coming from the cervical sympathetic; when this nerve is divided in the neck, the action of the muscle is weakened.

It probably also receives recurrent sensory fibres from the fifth.

7. *Facial*. Motor nerve to the muscles of the face; hence nerve of expression. Supplies also stylohyoid, digastric, buccinator, stapedius, muscles of the external ear, platysma, some muscles of the palate, viz. the levator palati and probably others. Secretory nerve of submaxillary and parotid gland. Receives afferent possibly efferent fibres from trigeminus and also from vagus. According to Vulpian contains vaso-motor fibres for the tongue and side of the face. The effects of paralysis of the facial, from the inability of the orbicularis to close the eye, the drawing of the face to the sound side, and the smoothness of the paralysed side, are very striking.

8. *Auditory Nerve*. Special nerve of hearing; afferent nerve for impulses other than auditory proceeding from the semicircular canals.

9. *Glosso-pharyngeal*. Motor nerve for levator palati, azygos uvulæ, stylo-pharyngeus, constrictor faucium medius. Special nerve of taste for the back of the tongue. General nerve of sensation for the root of the tongue, the soft palate, the pharynx (being here associated with the vagus), the Eustachian tube and the tympanum.

10. *Pneumogastric*. *Vagus*.

Efferent Fibres. Motor nerve for the muscles of the soft palate and pharynx, for the movements of the œsophagus (see p. 230), of

the stomach (see p. 232), of the intestines (see p. 229), for the muscles of the larynx, possibly for the plain muscular fibres of the trachea and bronchial divisions. Inhibitory nerve of the heart.

Afferent Fibres. Sensory nerve of the respiratory passages, and of the pharynx, œsophagus and stomach. Afferent nerve, augmenting and inhibiting, of the respiratory centre (see p. 290), afferent inhibitory nerve (depressor branch) of the medullary vaso-motor centre (see p. 161), afferent nerve producing salivary secretion (see p. 209), inhibiting pancreatic secretion (see p. 216).

Section of the vagi in the neck causes death by pneumonia; this has been regarded by some as an indication of 'trophic' action.

11. *Spinal accessory.* Motor nerve to the sterno-mastoid and trapezius muscles. It receives recurrent sensory fibres from the cervical nerves. Part of the spinal accessory blends with the pneumogastric, and the efferent effects (such as the movements of the larynx, pharynx, &c., and cardiac inhibition) of the united trunk seem to be largely due to the spinal accessory fibres contained in them. It is stated however that division of the spinal accessory before it joins the pneumogastric, does not entirely do away with either swallowing or the movements of the larynx. In the movements of the œsophagus and stomach, brought about by the vagus acting as an efferent nerve, the accessory fibres seem to have no share. The cardiac inhibitory fibres seem to be distinctly of accessory origin.

12. *Hypoglossal.* Motor nerve for the muscles of the tongue, and for all the muscles connected with the hyoid bone except the digastric, stylo-hyoid, mylo-hyoid, and middle constrictor of the pharynx; it also supplies the sterno-thyroid. It receives sensory fibres from the fifth and vagus, and is also connected with the three upper cervical nerves as well as with the sympathetic.

To Charles Bell is due the merit of having made the fundamental discovery of the distinction between motor and sensory fibres. Led to this view by reflecting on the distribution of the nerves, he experimentally verified his conclusions by observing that while mechanical irritation of a posterior root gave rise to no movements in the muscles to which the nerve was distributed, these were very evident when the anterior root was pricked or pinched. He printed his views for private circulation in 1811, under the title of "Idea of a New Anatomy of the Brain," and communicated to the Royal Society in July, 1821, a paper "On the Arrangement of the Nerves." In 1822 Majendie¹ shewed that section of the posterior root caused loss of sensation and section of the anterior root loss of motion: an observation no less epoch-making than that of Bell. Majendie was however led by the phenomena, which we can now explain as due to recurrent sensibility or reflex action, to believe that the distinction between the two roots was partial only; and it was not till Johannes Müller² some years afterwards conducted experiments on frogs and made use of galvanic stimu-

¹ *Journal de Physiol.* xi. p. 276.

² *Physiology*, Engl. ed. i. 691.

lation, that the doctrine of motor and sensory nerves became thoroughly established. The next great step was the establishment of the theory of Reflex Action. Although this important function of nervous centres was recognised dimly by older observers such as Whytt¹, more closely defined by Prochaska², and clearly grasped by Johannes Müller in 1833, it was independently discovered in 1832 by Marshall Hall³; and it was owing to the enthusiastic labours of the latter observer that the new doctrine was rapidly accepted and developed. Among the more important labours since that time may be mentioned the remarkable book of Flourens⁴, the work of Longet⁵, and the researches of Schiff⁶, Brown-Séguard⁷, and others. The work of Goltz⁸ on the frog, though small, contains many valuable facts and suggestions; and an admirable summary of the whole physiology of the nervous system is given by Vulpian⁹, to whom also we are indebted for many valuable observations. The chief of the more recent inquiries have been mentioned in the text.

¹ *On the Vital and other Involuntary Movements of Animals*, 1751.

² *Lehrsätze aus der Physiol.* 1797.

³ More fully in *Phil. Trans.* 1833.

⁴ *Rech. Exp. sur les Propriétés et les Fonctions du Système Nerveux*, 1st ed. in 1824, 2nd much enlarged and containing many new facts, in 1842.

⁵ *Anat. et Phys. du Système Nerveux*, 1841.

⁶ *Lehrb. d. Physiol.* 1858.

⁷ *Rech. et Exp. sur la Phys. de la moelle épin.* 1846, and numerous subsequent papers.

⁸ *Beiträge z. Lehre v. d. Functionen der Nervencentren des Frosches*, 1869.

⁹ *Leçons sur la Phys. générale et comparée du Système Nerveux*, 1866.

CHAPTER VII.

SPECIAL MUSCULAR MECHANISMS.

SEC. 1. THE VOICE.

A BLAST of air, driven by a more or less prolonged expiratory movement, throws into vibrations two elastic membranes—the *chordæ vocales*. These impart their vibrations to the column of air above them, and so give rise to the sound which we call the voice. Since the sound is generated in the vocal cords, we may speak of them and of those parts of the larynx which decidedly affect their condition as constituting the essential vocal apparatus; while the chamber above the vocal cords, comprising the ventricles of the larynx with the false vocal cords, the pharynx and the cavity of the mouth, the latter varying much in form, constitute a subsidiary apparatus of the nature of a resonance-tube, modifying the sound originating in the vocal cords. In the voice, as in other sounds, we distinguish: (1) Loudness. This depends on the strength of the expiratory blast. (2) Pitch. This depends on the length and tension of the vocal cords. Their *length* may be regarded as constant, or varying only with age. It consequently determines the range only of the voice, and not the particular note given out at any one time. The shrill voice of the child is determined by the shortness of the cords in infancy, and the voices of a soprano, tenor and baritone are all dependent on the respective lengths of their vocal cords. Their *tension* is on the contrary variable; and the chief problems connected with the voice refer to variations in the tension of the vocal cords. (3) Quality. This depends on the number and character of the overtones accompanying any fundamental note sounded, and is determined by a variety of circumstances, chief among which is the physical quality of the cords.

The vocal cords, attached in front to the thyroid cartilage, and behind in the processus vocales of the arytenoid cartilages. Hence a distinction has been drawn between the rima vocalis, *i. e.* the opening bounded latterly by the vocal cords, and the rima respiratoria, or space between the arytenoid cartilages behind the processus vocales; these names however are not free from objections. In quiet breathing (fig. 64 *B*) the two form together a V-shaped space, which, as we have seen (p. 264), in deep inspiration is widened into a rhomboidal open-

ing by the divergence of the processus vocales (fig. 64 C). When a note is about to be uttered, the vocal cords are by the approximation of the processus vocales brought into a position parallel to each other, and the whole rima is narrowed (fig. 64 A). By their paral-

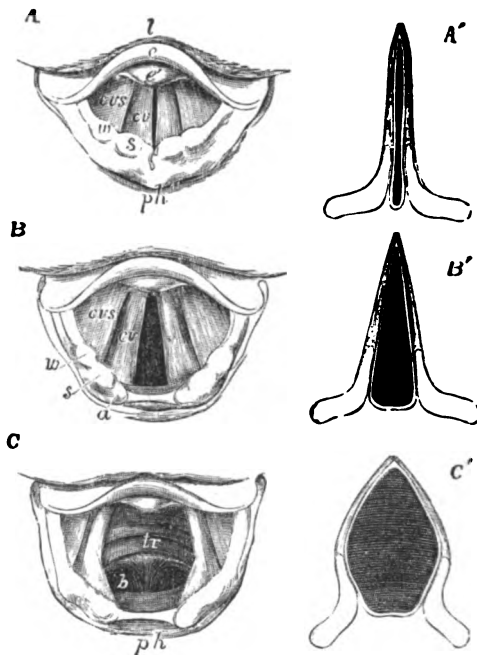

FIG. 64. THE LARYNX AS SEEN BY MEANS OF THE LARYNGOSCOPE IN DIFFERENT CONDITIONS OF THE GLOTTIS. (From Quain's Anatomy after Czermak.)

A. while singing a high note; *B.* in quiet breathing; *C.* during a deep inspiration. The corresponding diagrammatic figures *A'*, *B'*, *C'*, illustrate the changes in position of the arytenoid cartilages, and the form of the rima vocalis and rima respiratoria in the above three conditions.

l the base of the tongue; *e* the upper free part of the epiglottis; *e'* the tubercle or cushion of the epiglottis; *ph.* part of the anterior wall of the pharynx behind the larynx; *w* swelling in the aryteno-epiglottidean fold caused by the cartilage of Wrisberg; *s* swelling caused by the cartilage of Santorini; *a* the summit of the arytenoid cartilage; *cv* the true vocal cords; *cvs* the false vocal cords; *tr* the trachea with its rings; *b* the two bronchi at their commencement.

lelism and by the narrowness of the interval between them the cords are rendered more susceptible of being thrown into vibration by a moderate blast of air. The problems we have to consider are, first, by what means are the cords brought near to each other or drawn asunder as occasion demands; and secondly, by what means is the tension of the cords made to vary. We may speak of these two actions as narrowing or widening of the glottis, and tightening or relaxation of the vocal cords.

Narrowing of the Glottis. The change of form of the glottis is best understood when it is borne in mind that each arytenoid cartilage is, when seen in horizontal section (Fig. 64), somewhat of the form of a triangle, with an internal or median, an external, and a posterior side, the processus vocalis being placed in the anterior angle at the junction of the median and external sides. When the cartilages are so placed that the processus vocales are approximated to each other, and the internal surfaces of the cartilages nearly parallel, the glottis is narrowed. When on the contrary the cartilages are wheeled round on the pivots of their articulations, so that the processus vocales diverge, and the internal surfaces of the cartilages form an angle with each other, the glottis is widened.

There are several muscles forming together a group, which has been called by Henle the sphincter of the larynx. These are (1) the *thyro-ary-epiglotticus*, proceeding from the inner surface of the thyroid cartilage and from the arytenoid epiglottidean ligament, and sweeping round the outer ridge of the arytenoid cartilage of its own side to be inserted into the processus muscularis of the arytenoid cartilage of the other side: (2) the *thyro-arytenoideus externus*, passing from the reentrant angle of the thyroid cartilage to be inserted into the outer edge of the arytenoid cartilage of the same side: (3) the *thyro-arytenoideus internus*, passing from the angle of the thyroid cartilage to the processus vocalis and outer side of the arytenoid cartilage: (4) the *arytenoideus (posticus)*, passing transversely from one arytenoid cartilage to another. All these muscles, when they act together, grasp round the glottis and tend to close it up: and each of them, acting alone, has, with the exception of the last named (arytenoideus), the same effect. In addition to these, the *crico-arytenoideus lateralis*, which passes from the lateral border of the cricoid cartilage upwards and backwards to the outer angle of the arytenoid, by pulling this outer angle forwards throws the processus vocalis inwards, and so also narrows the glottis.

Widening of the Glottis. The *crico-arytenoideus posticus*, passing from the posterior surface of the cricoid cartilage to the outer angle of the arytenoid cartilage behind the attachment of the lateral crico-arytenoideus, pulls back this outer angle, and so causing the processus vocalis to move outwards, widens the glottis. The *arytenoideus posticus*, acting alone, has a similar effect.

Tightening of the Vocal Cords. The *crico-thyroideus* pulls the thyroid downwards and forwards, and so increases the distance between that cartilage and the arytenoids when the latter are fixed. Supposing then the arytenoideus and crico-arytenoideus posticus to fix the arytenoids, the effect of the contraction of the crico-thyroideus would be to tighten the vocal cords.

Slackening of the Vocal Cords. This is effected by the whole sphincter group just mentioned, but more especially by the *thyro-*

arytenoidei externus and *internus*; these acting alone, supposing the arytenoid cartilages to be fixed, would pull the thyroid cartilage upwards and backwards, and so shorten the distance between the processus vocales and that body.

Thus almost every movement of the larynx is effected not by one muscle only but by several, or at least by more than one, acting in concert. The movements which give rise to the voice are pre-eminently combined and co-ordinate movements. When we remember how a very slight variation in the tension of the vocal cords must give rise to a marked difference in the pitch of the note uttered, and yet what a multitude of fine differences of pitch are at the command of a singer of even moderate ability, it appears exceedingly probable that the various muscular combinations required to produce the possible variations in pitch are of such a kind that frequently a part only, possibly a few fibres only, of a particular muscle, may be thrown into contraction, while all the rest of the muscle remains quiet. Taking into view moreover the great range of pitch possessed by even common voices, as compared with the possible variations of tension of which the vocal cords in their natural length are capable, it has been suggested that some of the fibres of the thyro-arytenoideus internus, which passing either from the thyroid or from the arytenoid, appear to end in the vocal cords themselves, may, by fixing particular points of the cords, so to speak, 'stop' them; and by thus artificially shortening the length actually thrown into vibration, produce higher notes than the cords in their natural length are capable of producing. It has been also suggested that the processus vocales may overlap each other, and thereby shorten the length of cord available for vibration¹.

These various muscles are supplied by the vagus nerve, or rather by spinal accessory fibres running in the vagus-trunk. The superior laryngeal is the afferent nerve supplying the mucous membrane, but it also contains the motor fibres distributed to the crico-thyroid muscle; hence when this nerve is divided on one side the corresponding vocal cord is relaxed and high notes become impossible. It is worthy of notice that this, the chief tensor, and therefore the most important, muscle of the larynx, has a separate and distinct nervous supply.

According to some authors the arytenoideus posticus also receives its nervous supply from this nerve; but this is denied by Schech².

The inferior laryngeal or recurrent branch supplies all the other muscles. When this nerve is divided the voice is lost, since the approximation and parallelism of the vocal cords can no longer be effected. When in a living animal both recurrent nerves are divided, the glottis is seen to become immobile and partially dilated, the vocal cords assuming the position in which they are found in the body after death, and which may be considered as the condition of equilibrium

¹ Cf. Rühlmann, *Wien. Sitzungsbericht*. LIX. (1874) p. 257.

² *Zt. f. Biol.* ix. p. 258.

between the dilating and constricting muscles. During forcible inspiration the glottis passes from this condition in the direction of more complete dilation; during forcible expiration, the change is one of constriction. When the peripheral portion of one recurrent nerve is stimulated, the vocal cord of the same side is approximated to the middle line; when both nerves are stimulated, the vocal cords are brought together and the glottis is narrowed. Though the nerve is distributed to both dilating and constricting muscles, the latter overcome the former when the nerve is artificially stimulated. In the complete enclosure of the glottis, which is so important a part of the act of coughing (p. 309), the group of muscles which we have spoken of as constituting a sphincter is thrown into forcible contractions by the recurrent laryngeal nerve.

Though fundamentally a voluntary act, the utterance of a given note is not affected by the direct passage of simple volitional impulses down to the laryngeal muscles. So complex and co-ordinate a movement as that of sounding even a simple and natural note, requires a coordinating nervous mechanism in which, as in other complex muscular actions, afferent impulses play an important part. Auditory sensations, if not as important for an accurate management of the voice as are visual sensations for the movements of the eye, are yet of prime importance. This is recognized when we say that such and such a one whose power over his laryngeal muscles is imperfect, 'has no ear.'

The 'falsetto' voice is one not at present clearly understood. According to some authors the vocal cords are seen to be wide apart when falsetto notes are uttered, and not close and parallel as in the ordinary voice. Hence for the development of these notes, a stronger blast of air and a greater effort are required. When, as in an ordinary full voice, the glottis is very narrow, the trachea and bronchi serve the purpose of a resonance chamber; hence such a voice is spoken of as a 'chest' voice. In the falsetto voice, where the vocal cords are wide apart, this function of the air-tubes is in abeyance. This view is combated by Vacher¹, who, from observations on himself has come to the conclusion that the glottis is narrowed in both kinds of notes, the cords vibrating along their whole length in the chest notes, and along their anterior portions only in the high falsetto notes. According to him, therefore, the high notes are the result of a 'stopping' of the vocal cords, but whether this is effected by the action of the thyro-arytenoideus internus spoken of above, must be left at present uncertain. Johannes Müller was of opinion that in the falsetto notes the edges only of the vocal cord vibrate, while in the chest notes the whole width of each cord is involved. It is exceedingly probable that the falsetto notes are produced by some muscular manœuvre, since they may by exercise be uttered with comparative ease. The change from the chest to the falsetto range is an abrupt one, and the combined range may be very extensive, as in the case of persons who can carry on a duet, singing alternately for instance, in a tenor (chest) and a soprano (falsetto) voice. According to Vacher the rima respiratoria is always completely closed during singing, whether chest or falsetto notes, and not as Mandl thought in the latter only.

¹ *De la Voix*, Paris, 1877.

The ventricles of Morgagni are apparently of use in giving the vocal cords sufficient room for their vibrations. The purpose of the false vocal cords is not exactly known. Some authors think that in the falsetto voice they are brought down into contact with, and thus serve to stop, the true vocal cords.

At the age of puberty a rapid development of the larynx takes place, leading to a change in the range of the voice. The peculiar harshness of the voice when it is thus 'breaking' seems to be due to a temporary congested and swollen condition of the mucous membrane of the vocal cords accompanying the active growth of the whole larynx. The change in the mucous membrane may come on quite suddenly, the voice 'breaking' for instance in the course of a night.

SEC. 2. SPEECH.

Vowels.

Every sound, or every note (for all vocal sounds are musical sounds, when considered by themselves) caused by the vibrations of the vocal cords, besides its loudness due to the force of the expiratory blast, and its pitch due to the tension of the cords, has a quality of its own, due to the number and relative prominence of the overtones which accompany the fundamental tone. Some of these features which make up the quality are imposed on the note by the nature of the vocal cords, but still more arise from various modifications which the relative intensities of the overtones undergo through the resonance of the cavity of the mouth and throat. Whenever we hear a note sounded by the larynx we are able to recognize in it features which enable us to state that one or other of the 'vowels' is being uttered. Vowel sounds are in fact only extreme cases of quality, extreme prominence of certain overtones brought about by the shape assumed by the buccal and pharyngeal passages and orifices, as the vibrations pass through them. Each vowel has its appropriate and causative disposition of these parts. When *i* (ee in feet) is sounded, the sounding-tube of the upper air passages is made as short as possible, the larynx is raised and the lips are retracted, the whole cavity of the mouth taking on the form of a broad flask with a narrow neck. During the giving out of *e* (a in fat) the shape of the mouth is similar, but somewhat longer. For the production of *a* (as in father) the mouth is widely open, so that the buccal cavity is of the shape of a funnel with the apex at the pharynx. With *o*, the buccal cavity is again flask-shaped, with the mouth more closed than in *a*, but the lips, instead of being retracted as in *i* and *e*, are somewhat protruded, so that the sounding tube is prolonged. The greatest length of the tube is reached in *u* (oo), in which the larynx is depressed and the lips protruded as much as possible. While the two latter vowels are being uttered, the general form of the buccal cavity is that of a flask with a short neck and a small opening, the orifice being smaller for *u* than for *o*.

Each of these various 'vowel' forms of the mouth possesses a note of its own, one towards which it acts as a resonance chamber. Thus if several tuning-forks of various pitch be held while sounding before a mouth which has assumed the particular form necessary for sounding U, it will be found that the resonance will be particularly great with the fork having the pitch of the bass *b*-flat. Similarly the pitch of the treble *b* will be more intensified by the mouth moulded to sound O, the octave *b* above the treble will correspond to A, another octave higher to E, and still an octave higher to I. And it is the experience of singers that each vowel is sung with peculiar ease on a note having a prominent overtone corresponding to the tone proper to the mouth when moulded to utter the vowel. The precise nature of the vowel sounds however requires further investigation.

As the vibrations are travelling through the pharyngeal and buccal cavities, the posterior nares are closed by the soft palate; and it may be shewn, by holding a flame before the nostril, that no current of air issues from the nose when a vowel is properly said or sung. When the posterior nares are not effectually closed the sound acquires a nasal character. The same happens when the anterior nares are closed, as when the nose is held between the fingers, the nasal chamber then forming a cavity of resonance.

Consonants.

Vowels are, as their name implies, the only real vocal sounds; it is only on a vowel that a note can be said or sung. Our speech however is made up not only of vowels but also of consonants, *i. e.* of sounds which are produced not by the vibrations of the vocal cords but by the expiratory blast being in various ways interrupted or otherwise modified in its course through the throat and mouth.

The distinction between the two is however not an absolute one, since, as we have seen, the characters of the several vowels depend on the form of the mouth, and in the production of some consonants (B, D, M, N, &c.) vibrations of the vocal cords form a necessary though adjuvant factor.

Consonants have been classified according to the place at which the characteristic interruption or modification takes place. Thus it may occur,

1. At the lips, by the movement or position of the lips in reference to each other or to the teeth, giving rise to *labial* consonants.
2. At the teeth, by the movement or position of the front part of the tongue in reference to the teeth or the hard palate, giving rise to *dental* consonants.
3. In the throat, by the movement or position of the root of the tongue in reference to the soft palate or pharynx, giving rise to *guttural* consonants.

Among the dentals again may be distinguished the dentals commonly so called, such as T, the sibilants such as S, and the lingual L, all differing in the relative position of the tongue, teeth, and palate.

Consonants may also be classified according to the character of the movements which give rise to them. Thus they may be either *explosive* or *continuous*.

1. *Explosives*. In these the characters are given to the sound by the sudden establishment or removal of the appropriate interruption. Thus, in uttering the labial P, the lips are first closed, then an expiratory current of air is driven against them, and upon their being suddenly opened, the sound is generated. Similarly, the dental T is generated by the sudden removal of the interruption caused by the approximation of the tip of the tongue to the front of the hard palate, and the guttural K by the sudden removal of the interruption caused by the approximation of the root of the tongue to the soft palate.

The labial B differs from P, inasmuch as it is accompanied by vibrations of the vocal cords (that is, a vowel sound is uttered at the same time), and these vibrations continue after the removal of the interruption. Hence B is often spoken of as being uttered with voice and P without voice; and D and G (hard) with voice bear the same relation to T and K without voice.

The *continuous* consonants may further be divided into

2. *Aspirates*. In these the sound is generated by a rush of air through a constriction formed by the partial closure of the lips, or by the raising of the tongue against the hard or soft palate, &c. Thus F is sounded when the lips are brought into partial, and not as in P and B into complete approximation, and a current of air is driven through the narrowed opening. F is uttered without any accompanying vibration of the vocal cords, *i. e.* without voice. With voice it becomes V.

The sibilant S is formed by a rush of air past an obstruction caused by the partial closure of the teeth, the front of the tongue being depressed at the same time; and S accompanied with vibrations of the vocal cords becomes Z.

In Sh the dorsal surface of the tongue is raised so as to narrow the passage between that organ and the palate for a considerable portion of its length.

Th is formed by placing the tongue between the two partially open rows of teeth; and the hard and soft Th bear to each other the same relation as do P and B.

L is produced when the passage is closed in the middle by pressing the tip of the tongue against the hard palate and the air is allowed to escape at the sides of the tongue.

When the constriction in an aspirate is formed by the approximation of the root of the tongue to the soft palate, we have the guttural CH (as in loch) without voice and GH (as in lough) with voice.

3. *Resonants*. In these, all of which must have vibrations of the vocal cords as a basis, the usual passage through the mouth is closed

either in a labial, dental, or guttural, fashion and the peculiar character is given to the sound by the nasal chambers acting as a resonance cavity. Thus in M, the passage is closed by the approximation of the lips, in N, by the approximation of the tongue to the hard palate, and in NG by the approximation of the root of the tongue to the soft palate.

4. The various forms of R are often spoken of as *vibratory*, the characteristic sounds being caused by the vibration of some or other of the parts forming a constriction in the vocal passage. Thus the ordinary R is produced by vibrations of the point of the tongue elevated against the hard palate, the guttural R by the vibrations of the uvula or other parts of the walls of the pharynx; and in some languages there seems to be an R produced by the vibrations of the lips.

H is caused by the rush of air through the widely open glottis. When, in sounding a vowel, the sound is begun by a sudden change in the position of the vocal cords from one of divergence to one of approximation, the vowel is pronounced with the *spiritus asper*. When the vocal cords are brought together before the blast of air begins, the vowel is pronounced with the *spiritus lenis*. The Arabic H is produced by closing the rima vocalis, the epiglottis and false vocal cords being depressed, and sending a blast of air through the rima respiratoria.

On many of the above points however, there are great differences of opinion, the discussion of which as well as of other more rare consonantal sounds would lead us too far away from the purpose of this book. The following tabular statement must therefore be regarded as introduced for convenience only.

EXPLOSIVES.	<i>Labials</i> ,	without voice,P.
	"	with voice,B.
	<i>Dentals</i> ,	without voice,T.
	"	with voice,D.
	<i>Gutturals</i> ,	without voice,K.
	"	with voice,G (hard).
ASPIRATES.	<i>Labials</i> ,	without voice,F.
	"	with voice,V.
	<i>Dentals</i> ,	without voice,S, L, Sh, Th (hard).
	"	with voice,Z, Zh (in <i>azure</i> , the French j), Th (soft).
	<i>Gutturals</i> ,	without voice,CH (as in <i>loch</i>).
	"	with voice,GH (as in <i>lough</i>).
RESONANTS.	<i>Labial</i> ,M.
	<i>Dental</i> ,N.
	<i>Guttural</i> ,NG.
VIBRATORY.	<i>Labial</i> ,	not known in European speech.
	<i>Dental</i> ,	R (common).
	<i>Guttural</i> ,	R (guttural).

Whispering is speech without any employment of the vocal cords, and is effected chiefly by the lips and tongue. Hence in whispering the distinction between consonants needing and those not needing voice, such as B and P, becomes for the most part lost.

SEC. 3. LOCOMOTOR MECHANISMS.

The skeletal muscles are for the most part arranged to act on the bones and cartilages as on levers, examples of the first kind of lever being rare, and those of the third kind, where the power is applied nearer to the fulcrum than is the weight, being more common than the second. This arises from the fact that the movements of the body are chiefly directed to moving comparatively light weights through a great distance, or through a certain distance with great precision, rather than to moving heavy weights through a short distance. The fulcrum is generally supplied by a (perfect or imperfect) joint, and one end of the acting muscle is made fast by being attached either to a fixed point, or to some point rendered fixed for the time being by the contraction of other muscles. There are few movements of the body in which one muscle only is concerned; in the majority of cases several muscles act together in concert; nearly all our movements are coordinate movements. Where gravity or the elastic reaction of the parts acted on do not afford a sufficient antagonism to the contraction of a muscle or group of muscles, the return to the condition of equilibrium is provided for by the action either elastic or contractile of a set of antagonistic muscles; this is seen in the case of the face.

The **erect posture**, in which the weight of the body is borne by the plantar arches, is the result of a series of contractions of the muscles of the trunk and legs, having for their object the keeping the body in such a position that the line of gravity falls within the area of the feet. That this does require muscular exertion is shewn by the facts, that a person when standing perfectly at rest in a completely balanced position falls when he becomes unconscious, and that a dead body cannot be set on its feet. The line of gravity of the head falls in front of the occipital articulation, as is shewn by the nodding of the head in sleep. The centre of gravity of the combined head and trunk lies at about the level of the ensiform cartilage, in front of the tenth dorsal vertebra, and the line of gravity drawn from it passes behind a line joining the centres of the two hip-joints, so that the erect body would fall backward were it not for the action of the muscles passing from the thighs to the pelvis assisted by the anterior ligaments of the hip-joints. The line of gravity of the combined head, trunk and thighs falls moreover a little behind the knee-joints, so that some, though little, muscular exertion is required to prevent the knees from being bent. Lastly, the line of gravity of the whole body passes in front of the line drawn between the two ankle-joints,

the centre of gravity of the whole body being placed at the end of the sacrum; hence some exertion of the muscles of the calves is required to prevent the body falling forwards.

In **walking**, there is in each step a moment at which the body rests vertically on the foot of one, say the right leg, while the other, the left leg, is inclined obliquely behind with the heel raised and the toe resting on the ground. The left leg, slightly flexed to avoid contact with the ground, is then swung forward like a pendulum, the length of the swing or step being determined by the length of the leg; and the left toe¹ is brought to the ground. On this left toe as a fulcrum, the body is moved forward, the centre of gravity of the body describing a curve the convexity of which is upward, and the left leg necessarily becoming straight and rigid. As the body moves forward, a point will be reached similar to that with which we supposed the step to be started, the body resting vertically on the left foot, and the right leg being directed behind in an oblique position. The movement on the left foot however carries the body beyond this point, and in doing so swings the right leg forward until it is the length of a step in advance of its previous position, and its toe in turn forms a fulcrum on which the body, and with it the left leg, is again swung forward. Hence in successive steps the centre of gravity, and with it the top of the head, describes a series of consecutive curves, with their convexities upwards, very similar to the line of flight of many birds.

Since in standing on both feet the line of gravity falls between the two feet, a lateral displacement of the centre of gravity is necessary in order to balance the body on one foot. Hence in walking the centre of gravity describes not only a series of vertical, but also a series of horizontal curves, inasmuch as at each step the line of gravity is made to fall alternately on each standing foot. While the left leg is swinging, the line of gravity falls within the area of the right foot, and the centre of gravity is on the right side of the pelvis. As the left foot becomes the standing foot, the centre of gravity is shifted to the left side of the pelvis. The actual curve described by the centre of gravity is therefore a somewhat complicated one, being composed of vertical and horizontal factors. The natural step is the one which is determined by the length of the swinging leg, since this acts as a pendulum; and hence the step of a long-legged person is naturally longer than that of a person with short legs. The length of the step however may be diminished or increased by a direct muscular effort, as when a line of soldiers keep step in spite of their having legs of different lengths. Such a mode of marching must obviously be fatiguing, inasmuch as it involves an unnecessary expenditure of energy.

In slow walking there is an appreciable time during which, while

¹ This indicates perhaps what should be done rather than the actual practice; most people put the heel to the ground first, the contact with the toe coming later.

one foot is already in position to serve as a fulcrum, the other, swinging, foot has not yet left the ground. In fast walking this period is so much reduced, that one foot leaves the ground the moment the other touches it; hence there is practically no period during which both feet are on the ground together.

When the body is swung forward on the one foot acting as a fulcrum with such energy that this foot leaves the ground before the other, swinging, foot has reached the ground, there being an interval during which neither feet are on the ground, the person is said to be **running**, not walking.

In jumping this propulsion of the body takes place on both feet at the same time; in hopping it is effected on one foot only.

The locomotion of four-footed animals is necessarily more complicated than that of man. The simple walk, such as that of the horse, is executed in four times, with a diagonal succession: thus, right fore leg, left hind leg, left fore leg, right hind leg. In the amble, such as that of the camel, the two feet of the same side are put down at one and the same time, this movement being followed by a similar movement of the other two legs; it corresponds therefore very closely to human walking. In the trot, which corresponds to human running, the two diagonally opposite feet are brought to the ground at the same time, and the body is propelled forwards on them. Of the gallop and canter there are many varieties, and the movements become very complicated¹.

The other problems connected with the action of the various skeletal muscles of the body are too special to be considered here.

¹ See Marey, *La Machine Animale* (1876).

BOOK IV.

THE TISSUES AND MECHANISMS OF REPRODUCTION.

THE TISSUES AND MECHANISMS OF REPRODUCTION.

MANY of the individual constituent parts of the body are capable of reproduction, *i.e.* they can give rise to parts like themselves; or they are capable of regeneration, *i.e.* their places can be taken by new parts more or less closely resembling themselves. The elementary tissues undergo during life a very large amount of regeneration. Thus the old epithelium scales which fall away from the surface of the body are succeeded by new scales from the underlying layers of the epidermis; old blood corpuscles give place to new ones; worn out muscles, or those which have failed from disease, are renewed by the accession of fresh fibres; divided nerves grow again; broken bones are united; connective tissue seems to disappear and appear almost without limit; new secreting cells take the place of the old ones which are cast off; in fact, with the exception of some cases, such as cartilage, and these doubtful exceptions, all those fundamental tissues of the body, which do not form part of highly differentiated organs, are, within limits fixed more by bulk than by anything else, capable of regeneration. That regeneration by substitution of molecules, which is the basis of all life, is accompanied by a regeneration by substitution of mass.

In the higher animals regeneration of whole organs and members, even of those whose continued functional activity is not essential to the well being of the body, is never witnessed, though it may be seen in the lower animals; the digits of a newt may be restored by growth, but not those of a man. And even partial destruction of highly differentiated organs, such as the retina, is followed in the higher animals by very imperfect repair.

In the higher animals the reproduction of the whole individual can be effected in no other way than by the process of sexual generation, through which the female representative element or ovum is, under the influence of the male representative or spermatozoon, developed into an adult individual.

We do not purpose to enter here into any of the morphological problems connected with the series of changes through which the ovum becomes the adult being; or into the obscure biological inquiry as to how the simple all but structureless ovum contains within itself, in potentiality, all its future developments, and as to what is the essential nature of the male action. These problems and questions are fully discussed elsewhere; they do not properly enter into a work on physiology, except under the view that all biological problems are, when pushed far enough, physiological problems. We shall limit ourselves to a brief survey of the more important physiological phenomena attendant on the impregnation of the ovum, and on the nutrition and birth of the embryo.

CHAPTER I.

MENSTRUATION.

FROM puberty, which occurs at from 13 to 17 years of age, to the climacteric, which arrives at from 45 to 50 years of age, the human female is subject to a monthly discharge of ova from the ovaries, accompanied by special changes, not only in those organs but also in the Fallopian tubes and uterus, as well as by general changes in the body at large, the whole constituting 'menstruation.' The essential event in menstruation is the escape of an ovum from its Graaffian follicle. The whole ovary at this time becomes congested, and the ripe follicle bulging from the surface of the ovary, is grasped by the trumpet-shaped fringed opening of the Fallopian tube, itself turgid and congested; by what mechanism this is effected is not exactly known. The most projecting portion of the wall of the follicle, which has previously become excessively thin, is now ruptured, and the ovum, which having left its earlier position, is lying close under the projecting surface of the follicle, escapes, together with the cells of the *discus proligerus*, into the Fallopian tube. Thence it travels downwards, very slowly, by the action probably of the cilia lining the tube, though possibly its progress may occasionally be assisted by the peristaltic contractions of the muscular walls. The stay of the ovum in the Fallopian tube may extend to several days. There is an effusion of blood into the ruptured follicle, which is subsequently followed by histological changes in the coats of the follicle resulting in a *corpus luteum*. The discharge of the ovum is accompanied not only by a congestion or erection of the ovary and Fallopian tube, but also by marked changes in the uterus, especially in the uterine mucous membrane. While the whole organ becomes congested and enlarged, the mucous membrane, and especially the uterine glands, are distinctly hypertrophied. The swollen internal surface is thrown into folds which almost obliterate the cavity; and a hæmorrhagic discharge, often considerable in extent, constituting the menstrual or catamenial flow, takes place from the greater part of its surface. The blood as it passes through the vagina becomes somewhat altered by the acid secretions of that passage, and when scanty coagulates but slightly; when the flow however is considerable, distinct clots may make their appearance. It is not certain that mens-

truation, in the human subject at all events, is always accompanied by a discharge of an ovum; and it seems probable also that under certain circumstances, *ex. gr.* coitus, a discharge of an ovum may take place at other times than at the menstrual period. Since however the time during which both the ovum and the spermatozoon may remain in the female passages alive and functionally capable is considerable, probably extending to some days, coitus effected either some time after or some time before the menstrual escape of an ovum might lead to impregnation and subsequent development of an embryo; hence the fact that impregnation may follow upon coitus at some time after or before menstruation is no very cogent argument in favour of the view that such a coitus has caused an independent escape of an ovum. The escape of the ovum is said to precede the catamenial flow¹. If no spermatozoa come in contact with the ovum it dies, the uterine membrane returns to its normal condition, and no trace of the discharge of an ovum is left, except the corpus luteum in the ovary.

According to many authors the uterine mucous membrane is actually shed during menstruation, and subsequently entirely regenerated. According to their view the hæmorrhagic discharge is due to a positive 'solution of continuity.' In animals no discharge of blood, or a very scanty one, takes place at 'heat' or 'rut'; hence this point cannot be settled by comparative studies; and in the human subject the interval which must necessarily elapse between death and examination, is sufficiently long to render investigation very difficult. Williams² has brought forward strong evidence in favour of an actual loss of substance taking place. According to him, menstruation is accompanied by a rapid growth and subsequent rapid degeneration of the mucous membrane, for a depth reaching down to that layer of muscular fibres which passes among the deeper parts of the uterine glands. The growth and degeneration begin at an abrupt line near the cervix, and spread towards the fundus. The decay lays bare small blood-vessels, from which the hæmorrhage takes place.

It is obvious that in these phenomena of menstruation we have to deal with complicated reflex actions affecting not only the vascular supply but, apparently in a direct manner, the nutritive changes of the organs concerned. Our studies on the nervous action of secretion render it easy for us to conceive in a general way how the several events are brought about. It is no more difficult to suppose that the stimulus of the enlargement of a Graaffian follicle causes nutritive as well as vascular changes in the uterine mucous membrane, than it is to suppose that the stimulus of food in the alimentary canal causes those nutritive changes in the salivary glands or pancreas which constitute secretion. In the latter case we can to some extent trace out the chain of events; in the former case we hardly know more than that the maintenance of the lumbar cord is sufficient, as far as

¹ Williams, *Proc. Roy. Soc.* xxiii. 439.

² *Proc. Roy. Soc.* xxii. 297. See also his *Struct. Muc. Memb. of Uterus*, 1875.

the central nervous system is concerned, for the carrying on of the work. In the case of a dog observed by Goltz¹, 'heat' or menstruation took place as usual, though the spinal cord had been completely divided in the dorsal region while the animal was as yet a mere puppy.

The operation was performed in Dec. 1873. In the following May the animal was in excellent health, and there was not the slightest indication that any functional connection between the dorsal and lumbar portions of the spinal cord had been re-established. At the end of that month 'heat' came on, attended by all the ordinary phenomena psychical as well as physical. Impregnation was effected and the animal became gravid. The pregnancy, like the heat, was marked by all the usual signs; the mammary glands enlarged, and the usual mental accompaniments of the condition were present. Finally, one living and two dead puppies were born, the first without and the latter two with assistance; the mother however sank soon afterwards from puerperal peritonitis. The post-mortem examination shewed that there had been no regeneration of the divided spinal cord; the two portions were separated by more than a centimetre.

In this case the connection between the ovary on the one hand and the mammary gland, brain, &c., on the other, must, if a nervous one, have been furnished by the abdominal sympathetic. We may however suppose that the nexus was a chemical one; that the condition of the ovary and uterus effected a change in the blood, which in turn excited the mammary gland to increased action and produced special changes in the brain.

¹ Pflüger's *Archiv*, IX. (1874) p. 552.

CHAPTER II.

IMPREGNATION.

IN coitus the discharge of the semen containing the spermatozoa is most probably effected by means of the peristaltic contractions of the vesiculæ seminales and vasa deferentia, assisted by rhythmical contractions of the bulbo-cavernosus muscle, the whole being a reflex act, the centre of which appears to be in the lumbar spinal cord. Goltz¹ has shewn that in the dog, emission of semen can be brought about by stimulation of the glans penis after complete division of the spinal cord in the dorsal region. The emission of semen is preceded by an erection of the penis. This we have already seen, p. 165, is in part at least due to an increased vascular supply brought about by means of the nervi erigentes; it is probable, however, that the condition is further secured by a compression of the efferent veins of the corpora cavernosa by means of smooth muscular fibres present in those bodies. The semen being received into the female organs, which are at the time in a state of turgescence resembling the erection of the penis, but less marked, the spermatozoa find their way into the Fallopian tubes, and here (probably in its upper part) come in contact with the ovum. In the case of some animals impregnation may take place at the ovary itself. The passage of the spermatozoa is most probably effected mainly by their own vibratile activity; but in some animals a retrograde peristaltic movement travelling from the uterus along the Fallopian tubes has been observed; this might assist in bringing the semen to the ovum, but inasmuch as these movements are probably parts of the act of coitus and impregnation may be deferred till some time after that event, no great stress can be laid upon them.

The ascent of the spermatozoa is certainly puzzling if the cilia of the Fallopian tubes, which act from above downwards, continue their activity after the escape of the ovum. The spermatozoa directly they come in contact with the ovum become motionless; this suggests that the final cause of their activity is to enable them to reach the ovum.

As the result of the action of the spermatozoa on the ovum, the latter, instead of dying as when impregnation fails, awakes to great

¹ Pflüger's *Archiv*, VIII. (1874), p. 460.

nutritive activity accompanied by remarkable morphological changes; it enlarges and develops into an embryo. No sooner, however, have these changes begun in the ovum than correlative changes, brought about probably by reflex action, but at present most obscure in their causation, take place in the uterus. The mucous membrane of this organ, whether the coitus resulting in impregnation be coincident with a menstrual period or not, becomes congested, and a rapid growth takes place, the uterine glands, as in menstruation, becoming especially largely developed, accompanied by a rapid proliferation of the subepithelial tissue. Unlike the case of menstruation, however, this new growth does not give way to immediate decay and hæmorrhage, but remains; and may be distinguished as a new temporary lining to the uterus, the so-called decidua. Into this decidua the ovum, on its descent from the Fallopian tube, in which it has undergone developmental changes, extending most probably as far at least as the formation of the blastoderm if not farther, is received; and in this it becomes imbedded, the new growth closing in over it. Meanwhile the rest of the uterine structures, especially the muscular tissue, become also much enlarged; as pregnancy advances a large number of new muscular fibres are formed. As the ovum continues to increase in size, it bulges into the cavity of the uterus, carrying with it the portion of the decidua which has closed over it. Henceforward, accordingly, a distinction is made in the now well-developed decidua between the *decidua reflexa*, or that part of the membrane which covers the projecting ovum, and the *decidua vera*, or the rest of the membrane lining the cavity of the uterus, the two being continuous round the base of the projecting ovum. That part of the decidua which intervenes between the ovum and the nearest uterine wall is frequently spoken of as the *decidua serotina*. As the ovum develops into the fœtus with its membranes, the decidua reflexa becomes pushed against the decidua vera; about the end of the third month, in the human subject, the two come into complete contact all over, and ultimately the distinction between them is lost. In the region of the decidua serotina the allantoic vessels of the fœtus develop a placenta. For an account of the various changes by which these events are brought about, as well as of the history of the embryo itself, we must refer the reader to anatomical treatises.

CHAPTER III.

THE NUTRITION OF THE EMBRYO.

DURING the development of the chick within the hen's egg the nutritive material needed for the growth first of the blastoderm, and subsequently of the embryo, is supplied by the yolk, while the oxygen of the air passing freely through the porous shell, gains access to all the tissues both of the embryo and yolk, either directly or by the intervention of the allantoic vessels. The mammalian embryo, during the period which precedes the extension of the allantoic vessels into the cavities of the uterine walls to form the placenta, must be nourished by direct diffusion, first from the contents of the Fallopian tube, and subsequently from the decidua; and its supply of oxygen must come from the same sources. All analogy would lead us to suppose that, from the very first, oxidation is going on in the blastodermic and embryonic structures; but the amount of oxygen actually withdrawn from without is probably exceedingly small in the early stages, seeing that nearly the whole energy of the metabolism going on is directed to the building up of structures, the expenditure of energy in the form of either heat or external work being extremely small. The marked increase of bulk which takes place during the conversion of the mulberry mass into the blastodermic vesicle, shews that at this epoch a relatively speaking large quantity of water at least, and probably of nutritive matter, must pass from without into the ovum; and subsequently, though the blastoderm and embryo may for some time draw the material for their continued construction at first hand from the yolk-sac or umbilical vesicle, both this and they continue probably until the allantois is formed to receive fresh material from the mother by direct diffusion.

As the thin-walled allantoic vessels come into closer and fuller connection with the maternal uterine sinuses, until at last in the fully formed placenta the former are freely bathed in the blood streaming through the latter, the nutrition of the embryo becomes more and more confined to this special channel. The blood of the fœtus flowing along the umbilical arteries effects exchanges with the venous blood of the mother, and leaves the placenta by the umbilical vein richer in oxygen and nutritive material and poorer in carbonic acid and excretory products than when it issued from the fœtus.

As far as the gain of oxygen and the loss of carbonic acid are concerned these are the results of simple diffusion. Venous blood, as we have already seen, always contains a quantity of oxyhæmoglobin, and the quantity of this substance present in the blood of the uterine veins is sufficient to supply all the oxygen that the embryo needs. The blood of the fœtus, containing less oxygen than even the venous blood of the mother, will take up a certain though small quantity. The fœtal blood travelling in the umbilical artery must, in proportion to the extent of the nutritive changes going on in the embryo, possess a higher carbonic tension than that in the umbilical vein or uterine sinus; and by diffusion gets rid of this surplus during its stay in the placenta. The blood in the umbilical arteries and veins is therefore, relatively speaking, venous and arterial respectively, though the small excess of oxyhæmoglobin in the blood of the umbilical vein¹ is insufficient to give it a distinctly arterial colour, or to distinguish it as sharply from the more venous blood of the umbilical artery, as is ordinary arterial from ordinary venous blood. Thus the fœtus breathes by means of the maternal blood, in the same way that a fish breathes by means of the water in which it dwells.

The blood of the fœtus, according to Zuntz², is very poor in hæmoglobin corresponding to its low oxygen consumption. When the mother is asphyxiated, the fœtus is asphyxiated too, the oxygen of the latter passing back again in the blood of the former; and the asphyxia thus produced in the fœtus is much more rapid than that which results when the oxygen is used up by the tissues of the fœtus alone, as when the umbilicus is ligatured and the fœtus not allowed to breathe.

If oxygen and carbonic acid thus pass by diffusion to and from the mother and the fœtus, one might fairly expect that diffusible salts, proteids, and carbohydrates would be conveyed to the latter, and diffusible excretions carried away to the former in the same way; and if fats can pass directly into the portal blood during ordinary digestion, there can be no reason for doubting that this class of food-stuffs also would find its way to the fœtus through the placental structures. We do know from experiment that diffusible substances will pass both from the mother to the fœtus, and from the fœtus to the mother; but we have no definite knowledge as to the exact form and manner in which, during normal intra-uterine life, nutritive materials are conveyed to or excretions conveyed from the growing young. The placenta is remarkable for the great development of cellular structures apparently of an epithelial nature on the border-land between the maternal and fœtal elements; and it has been suggested that these form a temporary digestive and secretory (excretory) organ. But we have no exact knowledge of what actually does take place in these structures. From the cotyledons of ruminants may be obtained a

¹ Zweifel, *Arch. für Gynäkologie*, ix. Hft. 2.

² Pflüger's *Archiv*, xiv. (1877), p. 605.

white creamy-looking fluid, which from many features of its chemical composition might be almost spoken of as a 'uterine milk.'

Speaking broadly, the foetus lives on the blood of its mother, very much in the same way as all the tissues of any animal live on the blood of the body of which they are the parts.

For a long time all the embryonic tissues are 'protoplasmic' in character; that is, the gradually differentiating elements of the several tissues remain still embedded, so to speak, in undifferentiated protoplasm; and during this period there must be a general similarity in the metabolism going on in various parts of the body. As differentiation becomes more and more marked, it obviously would be an economical advantage for partially elaborated material to be stored up in various foetal tissues, so as to be ready for immediate use when a demand arose for it, rather than for a special call to be made at each occasion upon the mother for comparatively raw material needing subsequent preparatory changes. Accordingly, we find the tissues of the foetus at a very early period loaded with glycogen. The muscles are especially rich in this substance, but it occurs in other tissues as well. The abundance of it in the former may be explained partly by the fact that they form a very large proportion of the total mass of the foetal body, and partly by the fact that, while during the presence of the glycogen they contain much undifferentiated protoplasm, they are exactly the organs which will ultimately undergo a large amount of differentiation, and therefore need a large amount of material for the metabolism which the differentiation entails. It is not until the later stages of intra-uterine life, at about the fifth month, when it is largely disappearing from the muscles, that the glycogen begins to be deposited in the liver. By this time histological differentiation has advanced largely, and the use of the glycogen to the economy has become that to which it is put in the ordinary life of the animal; hence we find it deposited in the usual place. Besides being present in the foetal, glycogen is found also in the placental structures; but here probably it is of use, not for the foetus, but for the nutrition and growth of the placental structures themselves. We do not know how much carbohydrate material finds its way into the umbilical vein; and we cannot therefore state what is the source of the foetal glycogen; but it is at least possible, not to say probable, that it arises, as we have reason (p. 339) to think it may, from a splitting up of proteid material.

Concerning the rise and development of the functional activities of the embryo, our knowledge is almost a blank. We know scarcely anything about the various steps by which the primary fundamental qualities of the protoplasm of the ovum are differentiated into the complex phenomena which we have attempted in this book to expound. We can hardly state more than that while muscular contractility becomes early developed, and the heart probably, as in the chick, beats even before the blood-corpuscles are formed, movements of the fetus do not, in the human subject, become pronounced until after the fifth month; from that time forward they increase and sub-

sequently become very marked. They are often spoken of as reflex in character; but only a preconceived bias would prevent them from being regarded as largely automatic. The digestive functions are naturally, in the absence of all food from the alimentary canal, in abeyance; but the excretory functions of the liver are developed early, and about the third month bile-pigment and bile-salts find their way into the intestine. The quantity of bile secreted during intra-uterine life, accumulates in the intestine and especially in the rectum, forming, together with the smaller secretion of the rest of the canal, and some desquamated epithelium, the so-called meconium. Bile salts, both unaltered and variously changed, the usual bile pigments, and cholesterin, are all present in the meconium. The distinct formation of bile is an indication that the products of foetal metabolism are no longer wholly carried off by the maternal circulation; and to the excretory function of the liver there are now added those of the skin and kidney. The substances escaping by these organs find their way into the allantois or into the amnion, according to the arrangement of the foetal membranes in different classes of animals; in both these fluids urea representatives have been found as well as the ordinary saline constituents; the latter may or may not have been actually secreted. From the allantoic fluid of ruminants the body allantoin has been obtained, and human and other amniotic fluids have been found to contain urea.

About the middle of intra-uterine life, when the foetal circulation is in full development, the blood flowing along the umbilical vein is carried chiefly by the ductus venosus into the inferior vena cava and so into the right auricle. Thence it is directed by the valve of Eustachius through the foramen ovale into the left auricle, passing from which into the left ventricle it is driven into the aorta. Part of the umbilical blood, however, instead of passing directly to the inferior cava, enters by the portal vein into the hepatic circulation, from which it returns to the inferior cava by the hepatic veins. The inferior cava also contains blood coming from the lower limbs and lower trunk. Hence the blood which passing from the right auricle into the left auricle through the foramen ovale is distributed by the left ventricle through the aortic arch, though chiefly blood coming direct from the placenta, is also blood which on its way from the placenta has passed through the liver and blood derived from the tissues of the lower part of the body of the foetus. The blood descending as foetal venous blood from the head and limbs by the superior vena cava does not mingle with that of the inferior vena cava, but falls into the right ventricle, from which it is discharged through the ductus arteriosus (Botalli) into the aorta, below the arch, whence it flows partly to the lower trunk and limbs, but chiefly by the umbilical arteries to the placenta. A small quantity only of the contents of the right ventricle finds its way into the lungs. Now the blood which comes from the placenta by the umbilical vein direct into

the right auricle is, as far as the fœtus is concerned, arterial blood; and the portion of umbilical blood which traverses the liver probably loses at this epoch very little oxygen during its transit through that gland, the liver being at this period a simple excretory rather than a secretory or metabolic organ. Hence the blood of the inferior vena cava, though mixed, is on the whole arterial blood; and it is this blood which is sent by the left ventricle through the arch of the aorta into the carotid and subclavian arteries. Thus the head of the fœtus is provided with blood comparatively rich in oxygen. The blood descending from the head and upper limbs by the superior vena cava is distinctly venous; and this passing from the right ventricle by the ductus arteriosus is driven along the descending aorta, and together with some of the blood passing from the left ventricle round the aortic arch falls into the umbilical arteries and so reaches the placenta. The fœtal circulation then is so arranged, that while the most distinctly venous blood is driven by the right ventricle back to the placenta to be oxygenated, the most distinctly arterial (but still mixed) blood is driven by the left ventricle to the cerebral structures, which have more need of oxygen than the other tissues. In the later stages of pregnancy the mixture of the various kinds of blood in the right auricle increases preparatory to the changes taking place at birth. But during the whole time of intra-uterine life the amount of oxygen in the blood passing from the aortic arch to the medulla oblongata is sufficient to prevent any inspiratory impulses being originated in the medullary respiratory centre. This during the whole period elapsing between the date of its structural establishment, or rather the consequent full development of its irritability, and the epoch of birth, remains dormant; the oxygen-supply to the protoplasm of its nerve-cells is never brought so low as to set going the respiratory molecular explosions. As soon however as the intercourse between the maternal and umbilical blood is interrupted by separation of the placenta or by ligature of the umbilical cord, or when in any other way arterial blood ceases to find its way by the left ventricle to the medulla oblongata, the supply of oxygen in the respiratory centre sinks, and when the fall has reached a certain point an impulse of inspiration is generated and the fœtus for the first time breathes. When this first inspiratory movement is made, as under normal circumstances it is, with free access to air, the lungs are expanded, and the scanty supply of blood which at the moment was passing along the pulmonary artery from the right ventricle returns to the left auricle brighter and richer in oxygen than ever was the fœtal blood before. With the diminution of resistance in the pulmonary circulation caused by the expansion of the lungs, a larger supply of blood passes into the pulmonary artery instead of into the ductus arteriosus, and this derivation of the contents of the right ventricle increasing with the continued respiratory movements, the current through the latter canal at last ceases altogether, and its channel shortly after birth becomes obliterated.

Corresponding to the greater flow into the pulmonary artery, a larger and larger quantity of blood returns from the pulmonary veins into the left auricle. At the same time the current through the ductus venosus from the umbilical vein having ceased, the flow from the inferior cava has diminished; and the blood of the right auricle finding little resistance in the direction of the ventricle, which now readily discharges its contents into the pulmonary artery (where as we have seen (p. 119) the mean pressure and the peripheral resistance are very low), but finding in the left auricle, which is continually being filled from the lungs, an obstacle to its passage through the foramen ovale, ceases to take that course, and the foramen speedily becomes closed. Thus the foetal circulation, in consequence of the respiratory movements to which its interruption gives rise, changes its course into that characteristic of the adult.

CHAPTER IV.

PARTURITION.

IN spite of the increasing distension of its cavity, the uterus remains quiescent, as far as muscular contractions are concerned, until a certain time has been run. In the human subject the period of gestation generally lasts from 275 to 280 days, *i.e.* about 40 weeks, the general custom being to expect parturition at about 280 days from the last menstruation. Seeing that, in many cases, it is uncertain whether the ovum which develops into the embryo left the ovary at the menstruation preceding or succeeding coitus, or, as some have urged, independent of menstruation, by reason of the coitus itself, an exact determination of the duration of pregnancy is impossible.

In the cow the period of gestation is about 280 days, in the mare about 350, sheep about 150 days, dog about 60 days, rabbit about 30 days.

The extrusion of the fœtus is brought about, partly by rhythmical contractions of the uterus itself, and partly by a pressure exerted by the contraction of the abdominal muscles, similar to that described in defæcation. The contractions of the uterus are the first to appear, and their first effect is to bring about a dilation of the os uteri; it is not till the latter stages of labour, while the fœtus is passing into the vagina, that the action of the abdominal muscles is brought in.

The whole process of parturition may be broadly considered as a reflex act, the nervous centre being placed in the lumbar cord. In a dog, whose dorsal cord had been completely severed (see p. 544), parturition took place as usual; and the fact that, in the human subject, labour will progress quite naturally while the patient is unconscious from the administration of chloroform, shews that in woman also the whole matter is an involuntary action, however much it may be assisted by direct volitional efforts. That the uterus is capable of being thrown into contractions through reflex action, excited by stimuli applied to various afferent nerves, is well known. The contraction of the uterus, which is so necessary for the prevention of hæmorrhage after delivery, may frequently be brought about by pressure on the abdomen, by the introduction of foreign bodies into the vagina, and especially by the application of the child to the nipple. But we are not thereby justified in considering the rhythmical con-

tractions of the uterus during parturition as simple reflex acts excited by the presence of the fœtus. We are utterly in the dark as to why the uterus, after remaining apparently perfectly quiescent (or with contractions so slight as to be with difficulty appreciated) for months, is suddenly thrown into action, and within it may be a few hours gets rid of the burden it has borne with such tolerance for so long a time; none of the various hypotheses which have been put forward can be considered as satisfactory. And until we know what starts the active phase, we shall remain in ignorance of the exact manner in which the activity is brought about. The peculiar rhythmic character of the contractions, each 'pain' beginning feebly, rising to a maximum, then declining, and finally dying away altogether, to be succeeded after a pause by a similar pain just like itself, pain following pain like the tardy long-drawn beats of a slowly beating heart, suggests that the cause of the rhythmic contraction is seated, like that of the rhythmic beat of the heart, in the organ itself. And this view is supported by the fact that contractions of the uterus, similar to those of parturition, have been observed in animals even after complete destruction of the spinal cord.

The action of the abdominal muscles, on the other hand, is obviously a reflex act carried out by means of the spinal cord, the necessary stimulus being supplied by the pressure of the fœtus in the vagina, or by the contractions of the uterus. Hence the whole act of parturition may with reason be considered as a reflex one.

Whether the act be wholly a reflex or partly an automatic one, it can readily be inhibited by the action of the central nervous system. Thus emotions are a very frequent cause of the progress of parturition being suddenly stopped; as is well known, the entrance into the bedroom of a stranger often causes for a time the sudden and absolute cessation of 'labour' pains, which previously may have been even violent. Judging from the analogy of micturition, between which and parturition there are many points of resemblance, we may suppose that this inhibition of uterine contractions is brought about by an inhibition of the centre in the lumbar cord.

Experimental investigations into the movements of the uterus have been carried out chiefly on rabbits and dogs. In these animals, rhythmical contractions may occur spontaneously or be induced by direct stimulation after the connections of the uterus with the general nervous system have been entirely severed. The application of the interrupted current produces a local contraction frequently accompanied or followed by a general movement of the whole organ. This general movement may fail to make its appearance especially in an unimpregnated uterus (and indeed the results of stimulating the uterus whether directly or indirectly are for some reason or other remarkably inconstant); where it does occur, it possesses, like an artificially produced heart-beat (p. 141), characters resembling those of a reflex act.

Rhythmical contractions of the uterus may be induced by directly stimulating the spinal cord along any part of its course from the lumbar

region to the medulla oblongata, as well in a reflex manner by stimulation of the central ends of various spinal nerves¹. Stimulation of the cerebellum, crura cerebri and other parts of the brain as high up as the corpora striata and optic thalami, will also give rise to uterine contractions².

Basch and Hofmann³ distinguish, in the dog, two paths along which efferent impulses may pass from the central nervous system to the uterus; one, a sympathetic tract, consisting of nerves passing from the inferior mesenteric ganglion (lying in the dog at the extreme end of the aorta) to the hypogastric plexus, and the other, a spinal tract, consisting of branches passing from the sacral nerves across the pelvis to the same plexus, and being the representatives in the female of Eckhard's *nervi erigentes* in the male, see p. 165. Stimulation of the former produces contractions of the uterus chiefly circular in nature, with descent of the cervix, and dilation of the os; when the latter are stimulated, the uterus is shortened, as if by longitudinal contractions, the cervix ascends, and the os is closed. Both nerves apparently may take part in a contraction brought about in a reflex manner. When one tract is divided, the results of reflex stimulation resemble those of direct stimulation of the other tract. When both tracts are divided, stimulation of the central end of a spinal nerve, such as the sciatic, is without effect. The sacral nerves sharing in this spinal tract are branches from the first, second, and occasionally the third. Cyon⁴ however obtained no contractions of any kind on stimulating the peripheral ends of the divided first and second sacral nerves, though reflex contractions made their appearance when the central ends were stimulated. Basch and Hofmann further assert that the sympathetic tract contains vaso-constrictor and the spinal tract vaso-dilator nerves, both of which may be thrown into action in a reflex manner, the former, however, more readily than the latter. Whether connected or no with the central nervous system, the uterus may be thrown into contractions by a deficiency of oxygen or excess of carbonic acid in the blood. Hence when pregnant animals are asphyxiated, an extrusion of the fetus frequently takes place. There is no evidence however that the onset of labour is caused by a gradual diminution of oxygen in the blood, reaching at last to a climax. Nor are there sufficient facts to connect parturition with any condition of the ovary resembling that of menstruation.

After the expulsion of the foetus, the foetal placenta separates from the uterine walls, and is, together with the remnants of the membranes, expelled after it. The uterus then falls into a firm tonic contraction, similar to that of the emptied bladder, by which means hæmorrhage from the vessels torn by the separation of the placenta is avoided. The lining membrane of the uterus is gradually restored, the muscular elements are reduced by a rapid fatty degeneration, and in a short time the whole organ has returned to its normal condition.

¹ Schlesinger, *Wien. Med. Jahrb.* i. (1873), Hft. 4. Cyon, *Pflüger's Archiv*, viii. (1874), 349. Basch and Hofmann, *Wien. Med. Jahrb.* 1877, Hft. 4.

² Körner, *Studien Phys. Inst. Breslau*, iii. 34.

³ *Op. cit.*

⁴ *Op. cit.*

CHAPTER V.

THE PHASES OF LIFE.

THE child has at birth, on an average, rather less than one-third the maximum length, and about one-twentieth the maximum weight, to which in future years it will attain.

The composition of the body of the new-born babe, as compared with that of the adult, will be seen from the following table¹, in which the details are more full than those given on p. 355 :

	Weight of organ in percentage of Body-weight.		Weight of organ in adult, as compared with that of new-born babe taken as 1.
	New-born babe.	Adult.	
Eye	·28	·028	1·7
Brain	14·34	·237	3·7
Kidneys	·88	·48	12
Skin	11·3	6·3	12
Liver	4·39	2·77	13·6
Heart	·89	·52	15
Stomach and Intestine } Lungs	2·53	2·34	20
Skeleton	2·16	2·01	20
Muscles, &c.	16·7	15·35	26
Testicle	23·4	43·1	28
	·037	·8	60

It will be observed that the brain and eyes are, relatively to the whole body-weight, very much larger in the babe than in the adult, as is also, though to a less extent, the liver. This disproportion is a very marked embryonic feature, and as far as the brain and eye are concerned at least, has a morphological or phylogenetic, as well as a physiological or teleological, significance. Inasmuch as the smaller body has relatively the larger surface, the skin is naturally proportionately greater in the babe. It is chiefly by the accumulation of muscle or flesh, properly so called, that the child acquires the bulk and weight of the man, the skeletal frame-work, in spite of its being

¹ Vierordt, *Grundriss der Physiologie*, 5th ed. p. 605.

specifically lighter in its earlier cartilaginous condition, maintaining throughout life about the same relative weight.

The increase in stature is very rapid in early infancy, proceeding however by decreasing increments. According to Quetelet¹, there is a gain in height of about 20 centimetres during the first year, the 50 cm. babe enlarging to the 70 cm. infant of one year old; of about 9 during the second, of about 7 during the third, of about 6½ for the fourth, and so on, decreasing to rather below 6 for the succeeding ten or twelve years. During, or about puberty, there is again a somewhat sudden rise, with a subsequent more steady, but diminishing increase up to about the twenty-fifth year. From thence to about fifty years of age the height remains stationary, after which there may be a decrease, especially in extreme old age.

The increase in weight is also very rapid at first, and proceeding, like the height, with diminishing increments, may continue till about the fortieth year. After the sixtieth year a decline of variable extent is generally witnessed. It is a remarkable fact, however, that in the first few days of life, so far from there being an increase, there is an actual decrease of weight, so that, according to Quetelet, even on the seventh day, the weight still continues to be less than at birth.

The saliva of the babe is active on starch, and its gastric juice has good peptic powers, from which we may infer that its digestive processes in general are identical with that of the adult; but the fæces of the infant contain, besides a considerable quantity of undigested food (fat, casein, &c.), unaltered bile-pigment, and undecomposed bile-salts.

According to Hammarsten* the gastric juice of new-born puppies, though sufficiently acid to curdle milk, does not contain pepsin, or the lactic acid ferment; it is not till the third week that peptic digestion is set up, the casein previously taken being digested by the pancreatic juice; in young rabbits it appears a week earlier. Like Zweifel², Hammarsten however found pepsin in the stomach of the new-born babe. Zweifel states that the pancreatic juice in children, while active on fat and proteids from the first, is inert towards starch for the first two months; and that the amylolytic ferment is for the same period absent from the submaxillary, though present in the parotid saliva.

The heart of the babe (see Table, p. 556) is, relatively to its body-weight, larger than the adult, and the frequency of the heart-beat much greater, viz. about 130 or 140 per minute, falling to about 110 in the second year, and about 90 in the tenth year. Corresponding to the smaller bulk of the body, the whole circuit of the blood system is traversed in a shorter time than in the adult (12 seconds as against 22)³; and consequently the renewal of the blood in the tissues is exceedingly rapid. The respiration of

¹ *Physique Sociale* (1869), II. p. 13.

² *Ludwig's Festgabe* (1874), p. 116.

³ *Untersuch. u. d. Verdauungsapparat d. Neugeborenen*, 1874.

⁴ Vierordt, *op. cit.*

the babe is quicker than that of the adult, being at first about 35 per minute, falling to 28 in the second year, to 26 in the fifth year, and so onwards. The respiratory work, while it increases absolutely as the body grows, is, relatively to the body-weight, greatest in the earlier years. It is worthy of notice, that the absorption of oxygen is said to be relatively more active than the production of carbonic acid; that is to say, there is a continued accumulation of capital in the form of a store of oxygen-holding explosive compounds (see p. 286). This, indeed, is the striking feature of infant metabolism. It is a metabolism directed largely to constructive ends. The food taken represents, undoubtedly, so much potential energy; but before that energy can assume a vital mode, the food must be converted into tissue; and, in such a conversion, morphological and molecular, a large amount of energy must be expended. The metabolic activities of the infant are more pronounced than those of the adult, for the sake, not so much of energies which are spent on the world without, but as of energies which are for a while buried in the rapidly increasing mass of flesh. Thus the infant requires over and above the wants of the man, not only an income of energy corresponding to the energy of the flesh actually laid on, but also an income corresponding to the energy used up in making that living sculptured flesh out of the dead amorphous peptone sugar and salts, which serve as food. Over and above this, the infant needs a more rapid metabolism to keep up the normal bodily temperature. This, which is no less, indeed slightly (3°) higher, than that of the adult, requires a greater expenditure, inasmuch as the infant with its relatively far larger surface, and its extremely vascular skin, loses heat to a proportionately much greater degree than does the grown up man. It is a matter of common experience that children are more affected by cold than are adults.

This rapid metabolism is however not manifest immediately upon birth. During the first few days, corresponding to the loss of weight mentioned above, the respiratory activities of the tissues are feeble; the embryonic habits seem as yet not to have been completely thrown off, and, as was stated on p. 304, new-born animals bear with impunity a deprivation of oxygen, which would be fatal to them later on in life.

The quantity of urine passed, though scanty in the first two days, rises rapidly at the end of the first week, and in youth the quantity of urine passed is, relatively to the body-weight, larger than in adult life. This may be, at least in quite early life, partly due to the more liquid nature of the food, but is also in part the result of the more active metabolism. For not only is the quantity of urine passed, but also the amount of urea and some other urinary constituents excreted, relatively to the body-weight, greater in the child than in the adult. The presence of uric, of oxalic, and according to some, of hippuric acids in unusual quantities is a frequent characteristic of the urine of children. It is stated that calcic phosphates, and indeed the phos-

phases generally, are deficient, being retained in the body for the building up of the osseous skeleton.

Associated probably with these constructive labours of the growing frame is the prominence of the lymphatic system. Not only are the lymphatic glands largely developed and more active (as is probably shewn by their tendency to disease in youth), but the quantity of lymph circulation is greater than in later years. Characteristic of youth is the size of the thymus body, which increases up to the second year, and may then remain for a while stationary; but generally before puberty, has suffered a retrogressive metamorphosis, and frequently hardly a vestige of it remains behind. The thyroid body is also relatively greater in the babe than in the adult; the spleen, on the other hand, which grows rapidly in early infancy, is not only absolutely, but also relatively, greater in the adult. It need hardly be said that the recuperative power of infancy and early youth is very marked.

It would be beyond the scope of this work to enter into the psychical condition of the babe or the child, and our knowledge of the details of the working of the nervous system in infancy is too meagre to permit of any profitable discussion. It is hardly of use to say that in the young the whole nervous system is more irritable or more excitable than in later years; by which we probably to a great extent mean that it is less rigid, less marked out into what, in preceding portions of this work, we have spoken of as nervous mechanisms. It may be mentioned that, according to Soltmann¹, stimulation of Hitzig's cerebral areas, in new-born animals, does not give rise to the usual localised movements. The sense of touch, both as regards pressure and temperature, appears well developed in the infant as does also the sense of taste, and possibly, though this is disputed, that of smell. The pupil (larger in the infant than in the man) acts fully, and Donders² observed normal binocular movements of the eyes in an infant less than an hour old. The eye is (in man) from the outset fully sensitive to light, though of course visual perceptions are imperfect. As regards hearing, on the other hand, very little reaction follows upon sounds, *i.e.* auditory sensations seem to be dull during the first few days of life; this may be partly at least due to absence of air from the tympanum and a tumid condition of the tympanic mucous membrane. As the child grows up his senses rapidly culminate, and in his early years he possesses a general acuteness of sight, hearing, and touch, which frequently becomes blunted as his psychical life becomes fuller. Children however are said to be less apt at distinguishing colours than in sighting objects; but it does not appear whether this arises from a want of perceptive discrimination or from their being actually less sensitive to variations in hue. A characteristic of the nervous

¹ *Centrblt. Med. Wiss.* 1875, p. 209. *Jahrb. f. Kinderheilkunde* ix. (1875) 106.

² *Pflüger's Archiv*, xiii. (1876), p. 384.

system in childhood, the result probably of the more active metabolism of the body, is the necessity for long or frequent and deep slumber.

Dentition marks the first epoch of the new life. At about seven months the two cerebral incisors of the lower jaw make their way through the gum, followed immediately by the corresponding teeth in the upper jaw. The lateral incisors, first of the lower and then of the upper jaw, appear at about the ninth month, the first molars at about the twelfth month, the canines at about a year and a half, and the temporary dentition is completed by the appearance of the second molars usually before the end of the second year.

About the sixth year the permanent dentition commences by the appearance of the first permanent molar beyond the second temporary molar; in the seventh year the central permanent incisors replace their temporary representatives, followed in the next year by the lateral incisors. In the ninth year the temporary first molars are replaced by the first bicuspid, and in the tenth year the second temporary molars are similarly replaced by the second bicuspid. The canines are exchanged about the eleventh or twelfth year and the second permanent molars are cut about the twelfth or thirteenth year. There is then a long pause, the third or wisdom tooth not making its appearance till the seventeenth, or even twenty-fifth year, or in some cases not appearing at all.

Shortly after the conclusion of the permanent dentition (the wisdom teeth excepted) the occurrence of puberty marks the beginning of a new phase of life; and the difference between the sexes, hitherto merely potential, now becomes functional. In both sexes the maturation of the generative organs is accompanied by the well-known changes in the body at large; but the events are much more characteristic in the typical female than in the aberrant male. Though in the boy, the breaking of the voice and the rapid growth of the beard which accompany the appearance of active spermatozoa, are striking features, yet they are after all superficial. The curves of his increasing weight and height, and of the other events of his economy, pursue for a while longer an unchanged course; the boy does not become a man till some years after puberty; and the decline of his functional manhood is so gradual that frequently it ceases only when disease puts an end to a ripe old age. With the occurrence of menstruation, on the other hand, at from thirteen to seventeen years of age, the girl almost at once becomes a woman, and her functional womanhood ceases suddenly at the climacteric in the fifth decennium. And during the whole of the child-bearing period her organism is in a comparatively stationary condition. While just before the age of puberty, at about the twelfth year, the girl is growing at nearly the same rate as the boy, her curve of weight rises more rapidly about puberty, but from the nineteenth year onward to the climacteric, remains stationary, being followed subse-

quently by a late increase, so that while the man reaches his maximum of weight at about forty, the woman is at her greatest weight at about fifty¹.

Of the statical differences of sex, some, such as the formation of the pelvis, and the costal mechanism of respiration, are directly connected with the act of child-bearing, while others have only an indirect relation to that duty; and indications at least of nearly all the characteristic differences are seen at birth. The baby boy is heavier and taller than the baby girl, and the maiden of five breathes with her ribs in the same way as does the matron of forty. The woman is lighter and shorter than the man, the limits in the case of the former being from 1'444 to 1'740 metres of height and from 39·8 and 93·8 kilos of weight, in the latter from 1'467 to 1'890 of height, and from 49·1 to 98·5 kilos of weight². The muscular system and skeleton are both absolutely and relatively less in woman, and her brain is lighter and smaller than that of man, being about 1272 grammes to 1424. Her metabolism, as measured by the respiratory and urinary excreta, is also not only absolutely but relatively to the body-weight less, and her blood is not only less in quantity but also of lighter specific gravity and contains a smaller proportion of red corpuscles. Her strength is to that of man as about 5 to 9, and the relative length of her step as 1000 to 1157.

From birth onward (and indeed from early intra-uterine life) the increment of growth progressively diminishes. At last a point is reached at which the curve cuts the abscissa line, and the increment becomes a decrement. After the culmination of manhood at forty and of womanhood at the climacteric, the prime of life declines into old age. The metabolic activity of the body, which at first was sufficient not only to cover the daily waste, but to add new material, later on is able only to meet the daily wants, and at last is too imperfect even to sustain in its entirety the existing frame. Neither as regards vigour and functional capacity, nor as regards weight and bulk, do the turning-points of the several tissues and organs coincide either with each other or with that of the body at large. We have already seen that the life of such an organ as the thymus is far shorter than that of its possessor. The eye is in its dioptric prime in childhood, when its media are clearest and its muscular mechanisms most mobile, and then it for the most part serves as a toy; in later years, when it could be of the greatest service to a still active brain, it has already fallen into a clouded and rigid old age. The skeleton reaches its limit very nearly at the same time as the whole frame reaches its maximum of height, the coalescence of the various epiphyses being pretty well completed by about the twenty-fifth year. Similarly the muscular system in its increase tallies with the weight of the whole body. The brain, in spite of the increasing complexity of structure and function to which it continues to attain even in

¹ Quetelet *op. cit.*

² Quetelet *op. cit.* II. p. 63.

middle life, early reaches its limit of bulk and weight. At about seven years of age it attains what may be considered as its first limit, for though it may increase somewhat up to twenty, thirty, or even later years, its progress is much more slow after than before seven. The vascular and digestive organs as a whole may continue to increase even to a very late period. From these facts it is obvious that though the phenomena of old age are, at bottom, the result of the individual decline of the several tissues, they owe many of their features to the disarrangement of the whole organism produced by the premature decay or disappearance of one or other of the constituent bodily factors. Thus, for instance, it is clear that were there no natural intrinsic limit to the life of the muscular and nervous systems, they would nevertheless come to an end in consequence of the nutritive disturbances caused by the loss of the teeth. And what is true of the teeth is probably true of many other organs, with the addition that these cannot, like the teeth, be replaced by mechanical contrivances. Thus the term of life which is allotted to a muscle by virtue of its molecular constitution, and which it could not exceed were it always placed under the most favourable nutritive conditions, is, in the organism, determined by the similar life-terms of other tissues; the future decline of the brain is probably involved in the early decay of the thymus.

Two changes characteristic of old age are the so-called calcareous and fatty degenerations. These are seen in a completely typical form in cartilage, as, for instance, in the ribs; here the protoplasm of the cartilage-corpuscle becomes hardly more than an envelope of fat globules, and the supple matrix is rendered rigid with amorphous deposits of calcic phosphates and carbonates, which are at the same time the signs of past, and the cause of future nutritive decline. And what is obvious in the case of cartilage is more or less evident in other tissues. Everywhere we see a disposition on the part of protoplasm to fall back upon the easier task of forming fat rather than to carry on the more arduous duty of manufacturing new material like itself; everywhere almost we see a tendency to the replacement of a structured matrix by a deposit of amorphous material. In no part of the system is this more evident than in the arteries; one common feature of old age is the conversion by such a change of the supple elastic tubes into rigid channels, whereby the supply to the various tissues of nutritive material is rendered increasingly more difficult, and their intrinsic delay proportionately hurried.

Of the various tissues of the body the muscular and nervous are however those in which functional decline, if not structural decay, becomes soonest apparent. The dynamic coefficient of the skeletal muscles diminishes rapidly after thirty or forty years of life, and a similar want of power comes over the plain muscular fibres also; the heart, though it may not diminish, or even may still increase in weight, possesses less and less force, and the movements of the

intestine, bladder, and other organs, diminish in vigour. In the nervous system, the lines of resistance, which, as we have seen, help to map out the central organs into mechanisms, and so to produce its multifarious actions, become at last hinderances to the passage of nervous impulses in any direction, while at the same time the molecular energy of the impulses themselves becomes less. The eye becomes feeble, not only from cloudiness of the media and presbyopic muscular inability, but also from the very bluntness of the retina; the sensory and motor impulses pass with increasing slowness to and fro, the central nervous system and the brain becomes a more and more rigid mass of protoplasm, the molecular lines of which rather mark the history of past actions than serve as indications of present potency. The epithelial glandular elements seem to be those whose powers are the longest preserved, and hence the man who in the prime of his manhood was a 'martyr to dyspepsia' by reason of the sensitiveness of his gastric nerves and the reflex inhibitory and other results of their irritation, in his later years, when his nerves are blunted, and when therefore his peptic cells are able to pursue their chemical work undisturbed by extrinsic nervous worries, eats and drinks with the courage and success of a boy.

Within the range of a lifetime are comprised many periods of a more or less frequent recurrence. In spite of the aids of a complex civilisation, all tending to render the conditions of his life more and equable, man still shews in his economy the effects of the seasons. Some of these are the direct results of varying temperature, but some probably, such as the gain of weight in winter and the loss in summer, are habits acquired by descent. Within the year, an approximately monthly period is manifested in the female by menstruation, though there is no exact evidence of even a latent similar cycle in the male. The phenomena of recurrent diseases, and the marked critical days of many other maladies, point to cycles of smaller duration than that of the moon's revolution, for it seems probable that in these cases the recurrence is to be attributed rather to variations in the medium of the disease, than to periodical phases in the disease-producing germ itself.

Prominent among all other cyclical events is the fact that all animals possessing a well-developed nervous system, must, night after night, or day after day, or at least time after time, lay them down to sleep. The salient feature of sleep is the cessation of the automatic activity of the brain; it is the diastole of the cerebral beat. But the condition is not confined to the cerebral hemispheres; all parts of the body either directly or indirectly take share in it. The phenomena of sleep are perhaps seen in their simplest form in the winter-sleep or hibernation, to which especially cold-blooded animals, but also to some extent warm-blooded animals are subject. In these cases the cold of winter slackens the vibrations and lessens the explosions of the protoplasm, not only of nervous but also of muscular and glandular structures; indeed the activity of the whole

body is lowered, in some respects almost to actual arrest. At the same time that the labour of the cerebral molecules becomes insufficient to develop consciousness, the respiratory centre is either wholly quiescent or discharges feeble impulses at rare intervals, and the heart beats with a slow infrequent stroke, not by reason of any inhibitory restraint, but because its very substance in its slow molecular travail can gather head for explosions only after long pauses of rest. And such few and distant beats as do occur are amply sufficient to meet the needs of the feeble metabolism of the several tissues. The sleep of every day differs from the sleep of winter-cold chiefly because the slackening of molecular activities is due in the former not to extrinsic but to intrinsic causes, not to changes in the medium, but to exhaustion of the subject, and because the phenomena are largely confined to the cerebral hemispheres. It is true that the whole body shares in the condition; the pulse and breathing are slower, the intestine and other internal muscular mechanisms are more or less at rest, the secreting organs are less active, and the whole metabolism and the dependent temperature of the body are lowered; but we cannot say at present how far these are the indirect results of the condition of the nervous system, or how far they indicate a partial slumbering of the several tissues. We are not at present in a position to trace out the events which culminate in this inactivity of the cerebral structures. It has been urged¹ that during sleep the brain is anæmic; but even if this anæmia is a constant accompaniment of sleep, it must, like the vascular condition of a gland or any other active organ, be regarded as an effect, or at least as a subsidiary event rather than as a primary cause. The explanation of the condition is rather to be sought in purely molecular changes; and the analogy between the systole and diastole of the heart, and the waking and sleeping of the brain, may be profitably pushed to a very considerable extent. The sleeping brain in many respects closely resembles a quiescent but still living ventricle. Both are as far as outward manifestations are concerned at rest, but both may be awoke to activity by an adequately powerful stimulus. Both, though quiescent are irritable, in both the quiescence will ultimately give place to activity, and in both an appropriate stimulus applied at the right time will determine the change from rest to action. Just as a single prick will under certain circumstances awake a ventricle, which for some seconds has been motionless, into a rhythmic activity of many beats, so a loud noise will start a man from sleep into a long day's wakefulness. And just as in the heart the cardiac irritability is lowest at the beginning of the diastole and increases onwards till a beat bursts out, so is sleep deepest at its commencement after the day's labour; thence onward slighter and slighter stimuli are needed to wake the sleeper.

¹ Durham, *Guy's Hospital Reports*, Vol. VI. 1860.

Kohlschütter¹, judging of the depth of ordinary nocturnal sleep by the intensity of the noise required to wake the sleeper, concludes that, increasing very rapidly at first, it reaches its maximum within the first hour; from thence it diminishes, at first rapidly, but afterwards more slowly. At the end of an hour and a half it falls to one-fourth, at the end of two hours to one-eighth of its maximal intensity, and thence onward diminishes with gradually diminishing decrements.

We cannot at present make any definite statements concerning the nature of the molecular changes which determine this rhythmic rise and fall of cerebral irritability. Preyer², leaning towards the view that the accumulation of the products of protoplasmic activity may become in the end an obstruction to that activity, has been led to think that the presence of lactic acid, one of the products certainly of muscular and probably of nervous metabolism, tends to produce sleep; but this is doubtful. The suggestion of Pflüger³, that the diminution of irritability, and consequent suspension of automatism, is dependent on the exhaustion of the store of intramolecular oxygen (p. 286), is more worthy of attention.

As was previously stated (p. 371), there is at present at least no satisfactory evidence that the assumption of oxygen is directly dependent on the time of day, the striking result obtained by Pettenkofer and Voit there quoted not being corroborated by subsequent trials⁴. The hypothesis of Pflüger, therefore, unless subsequent researches reinstate Pettenkofer and Voit's first view, needs an addition to explain how it is that the store of intramolecular oxygen becomes exhausted in the nervous system. Henke⁵ had previously put forward a not wholly unlike hypothesis, as had also Sommer⁶.

The phenomena of sleep shew very clearly to how large an extent an apparent automatism is the ultimate outcome of the effects of antecedent stimulation⁷. When we wish to go to sleep we withdraw our automatic brain as much as possible from the influence of all extrinsic stimuli; and an interesting case is recorded⁸ of a lad whose connection with the external world was, from a complicated anæsthesia, limited to that afforded by a single eye and a single ear, and who could be sent to sleep at will, by closing the eye and stopping the ear.

The cycle of the day is however manifested in many other ways than by the alternation of sleeping and waking, with all the indirect effects of these two conditions. There is a diurnal curve of temperature (see p. 379) apparently independent of all immediate

¹ *Zeitschr. f. Rat. Med.* xvii. (1862) p. 209, xxxiv. (1869) p. 42.

² *Centralblatt f. Med. Wiss.* 1875, p. 577. *Ueber die Ursache des Schlafes*, 1877.

³ *Pflüger's Archiv*, x. (1875) p. 468.

⁴ *Sitzungsbericht. Acad. Wiss. München*, 1866—67.

⁵ *Zeitschr. f. Rat. Med.* xiv. (1861) p. 363.

⁶ *Zeitschr. f. Rat. Med.* xxxiii. (1868).

⁷ Cf. Heubel. *Pflüger's Archiv*, xiv. (1877) 153.

⁸ *Pflüger's Archiv*, xv. (1877) p. 573.

circumstances, the hereditary impress of a long past sequence of days and nights. Even the pulse, so sensitive of all bodily changes, shews, running through all the immediate effects of the changes of the minute and the hour, the working of a diurnal influence which cannot be accounted for by waking and sleeping, by working and resting, by meals and abstinence between meals. And the same may be said concerning the rhythm of respiration, and the products of pulmonary, cutaneous and urinary excretion. There seems to be a daily curve of bodily metabolism, which is not the product of the day's events. Within the day we have the narrower rhythm of the respiratory centre with the accompanying rise and fall of activity in the vaso-motor centres. And lastly, as the fundamental fact of all bodily periodicity is that alternation of the heart's systole and diastole which ceases only at death. Though, as we have seen, the intermittent flow in the arteries is toned down in the capillaries to an apparently continuous flow, still the constantly repeated cycle of the cardiac shuttle must leave its mark throughout the whole web of the body's life. Our means of investigation are, however, still too gross to permit us to track out its influence. Still less are we at present in a position to say how far the fundamental rhythm of the heart itself, that rhythm which is influenced, but not created by the changes of the body of which it is the centre, is the result of cosmical changes, the reflection as it were in little of the cycles of the universe, or how far it is the outcome of the inherent vibrations of the molecules which make up its substance.

CHAPTER VI.

DEATH.

WHEN the animal kingdom is surveyed from a broad stand-point, it becomes obvious that the ovum, or its correlative the spermatozoon, is the goal of an individual existence: that life is a cycle beginning in an ovum and coming round to an ovum again. The greater part of the actions which, looking from a near point of view at the higher animals alone, we are apt to consider as eminently the purposes for which animals come into existence, when viewed from the distant outlook whence the whole living world is surveyed, fade away into the likeness of the mere byplay of ovum-bearing organisms. The animal body is in reality a vehicle for ova; and after the life of the parent has become potentially renewed in the offspring, the body remains as a cast-off envelope whose future is but to die.

Were the animal frame not so complicated a machine as it is, death might come as a simple and gradual dissolution, the 'sans everything' being the last stage of the successive loss of fundamental powers. As it is, however, death is always more or less violent; the machine comes to an end by reason of the disorder caused by the breaking down of one of its parts. Life ceases not because the molecular powers of the whole body slacken and are lost, but because a weakness in one or other part of the machinery throws its whole working out of gear.

We have seen that the central factor of life is the circulation of the blood, but we have also seen that blood is not only useless, but injurious, unless it be duly oxygenated; and we have further seen that in the higher animals the oxygenation of the blood can only be duly effected by means of the respiratory muscular mechanism, presided over by the medulla oblongata. Thus the life of a complex animal is, when reduced to a simple form, composed of three factors: the maintenance of the circulation, the access of air to the hæmoglobin of the blood, and the functional activity of the respiratory centre; and death may come from the arrest of either of these. As Bichat put it, death takes place by the heart or by the lungs or by the brain. In reality, however, when we push the analysis further, the central fact of death is the stoppage of the heart, and the consequent arrest of the circulation; the tissues then all die, because they

lose their internal medium. The failure of the heart may arise in itself, on account of some failure in its nervous or muscular elements, or by reason of some mischief affecting its mechanical working. Or it may be due to some fault in its internal medium, such for instance as a want of oxygenation of the blood, which in turn may be caused by either a change in the blood itself, as in carbonic oxide poisoning, or by a failure in the mechanical conditions of respiration, or by a cessation of the action of the respiratory centre. The failure of this centre, and indeed that of the heart itself, may be caused by nervous influences proceeding from the brain, or brought into operation by means of the central nervous system; it may, on the other hand, be due to an imperfect state of blood, and this in turn may arise from the imperfect or perverse action of various secretory or other tissues. The modes of death are in reality as numerous as are the possible modifications of the various factors of life; but they all end in a stoppage of the circulation, and the withdrawal from the tissues of their internal medium. Hence we come to consider the death of the body as marked by the cessation of the heart's beat, a cessation from which no recovery is possible; and by this we are enabled to fix an exact time at which we say the body is dead. We can, however, fix no such exact time to the death of the individual tissues. They are not mechanisms, and their death is a gradual loss of power. In the case of the contractile tissues, we have in rigor mortis an apparently fixed term, by which we can mark the death of the muscles. If we admit that after the onset of rigor mortis recovery of irritability is impossible, then a rigid muscle is one permanently dead. In the case of the other tissues, we have no such objective sign, since the rigor mortis of simple protoplasm manifests itself chiefly by obscure chemical signs. And in all cases it is obvious that the possibility of recovery, depending as it does on the skill and knowledge of the experimenter, is a wholly artificial sign of death. Yet we can draw no other sharp line between the seemingly dead tissue whose life has flickered down into a smouldering ember which can still be fanned back again into flame, and the aggregate of chemical substances into which the decomposing tissue crumbles.

Moreover, the failure of the heart is at bottom loss of irritability, and the possibility of recovery here also rests, as far as is known at present, on the skill and knowledge of those who attempt to recover. So that after all the signs of the death of the whole body are as artificial as those of the death of the constituent tissues.

APPENDIX.

APPENDIX.

ON THE CHEMICAL BASIS OF THE ANIMAL BODY.

NATIVE protoplasm, whenever it can be obtained in sufficient quantity for chemical analysis, is found to contain representatives of three large classes of chemical substances, *viz.* proteids, carbohydrates and fats, in association with smaller quantities of various saline and other crystalline bodies. By proteids are meant bodies containing carbon, oxygen, hydrogen and nitrogen in a certain proportion, varying within narrow limits, and having certain general features; they are frequently spoken of as albuminoids. By carbohydrates are meant starches and sugars and their allies. Of these three classes of bodies, the proteids form the chief mass of ordinary protoplasm, but fats and carbohydrates are never wholly absent. To obtain evidence of the presence of any one of them in living protoplasm we are obliged to submit the protoplasm to destructive analysis. We do not at present know anything definite about the molecular composition of active living protoplasm; but it is more than probable that its molecule is a large complex one in which a proteid substance is peculiarly associated with a complex fat and with some representative of the carbohydrate group, *i.e.* that each molecule of protoplasm contains residues of each of these three great classes.

The whole animal body is modified protoplasm. Consequently when we examine the various tissues and fluids from a chemical point of view, we find present in different places, or at different times, several varieties and derivatives of the three chief classes; we find many forms of proteids and derivatives of proteids in the forms of gelatine, chondrin, &c.; many varieties of fats; and several kinds of carbohydrates.

We find moreover many other bodies which we may regard as stages in the constructive or destructive metabolism of both native and differentiated protoplasm, and which are important not so much from the quantity in which they occur in the animal body at any one time as from their throwing light on the nature of animal metabolism; these are such bodies as urea, lactic acid, and the extractives in general.

In the following pages the chemical features of the more important of these various substances which are known to occur in the animal body will be briefly considered, such characters only being described as possess or promise to possess physiological interest. The physiological function of any substance must depend ultimately on its molecular (including its chemical) nature; and though at present our chemical knowledge of the constituents of an animal body gives us but little insight into their physiological properties, it cannot be doubted that such chemical information as is attainable is a necessary preliminary to all physiological study.

PROTEIDS.

These form the principal solids of the muscular, nervous, and glandular tissues, of the serum of blood, of serous fluids, and of lymph. In a healthy condition, sweat, tears, bile and urine contain mere traces, if any, of proteids. Their general percentage composition may be taken as

	O.	H.	N.	C.	S.
From	20·9	6·9	15·2	51·5	0·3
to	23·5	7·3	17·0	54·5	2·0

(Hoppe-Seyler¹.)

These figures are obtained from a consideration of numerous analyses, slight differences in the various results being immaterial, where the purity of the substance operated upon cannot be definitely determined.

In addition to the above constituents, proteids leave on ignition a variable quantity of ash. In the case of egg-albumin the principal constituents of the ash are chlorides of sodium and potassium, the latter greatly exceeding the former in amount. The remainder consists of sodium and potassium, in combination with phosphoric, sulphuric, and carbonic acids, and very small quantities of calcium, magnesium and iron, in union with the same acids. There is also a trace of silica². The ash of serum-albumin contains an excess of sodium chloride, but the ash of the proteids of muscle contains an excess of potash salts and phosphates. The nature of the connection of the ash with the proteid is still a matter of obscurity. Globin from hæmoglobin is free from ash.

Proteids are all amorphous; some are soluble, some insoluble in water, and all are for the most part insoluble in alcohol and æther; they are all soluble in strong acids and alkalis, but in becoming dissolved mostly undergo decomposition. Their solutions possess a left-handed rotatory action on the plane of polarisation, the amount depending on various circumstances, and being, with one exception, *viz.* peptones, changed by heating.

¹ *Hdb. Phys. Path. Chem. Anal.* Ed. iv. (1875) p. 223.

² See Gmelin, *Hdb. Org. Chem.* Bd. viii. p. 285.

Their presence may be detected by the following tests.

1. Heated with strong nitric acid, they turn yellow, and this colour is, on the addition of ammonia, changed to a deep orange hue. (Xanthoproteic reaction.)

2. With Millon's reagent they give, when present in sufficient quantity, a precipitate, which, with the supernatant fluid, turns red on heating. If they are only present in traces, no precipitate is obtained, but merely the red colouration.

3. With caustic soda solution, and one or two drops of a solution of cupric sulphate, a violet colour is obtained, which deepens on boiling.

The above serve to detect the smallest traces of proteids. The two following tests may be used when there is more than a trace present.

4. Render the fluid strongly acid with acetic acid, and add a few drops of a solution of ferrocyanide of potassium; a precipitate shews the presence of proteids.

5. Render the fluid, as before, strongly acid with acetic acid, add an equal volume of a concentrated solution of sodium sulphate, and boil. A precipitate is formed if proteids are present.

This last reaction is useful, not only on account of its exactness, but also because the reagents used produce no decomposition of other bodies which may be present; and hence after filtration the same fluid may be further analysed for other substances. Additional methods of freeing a solution from proteids are: acidulating with acetic acid and boiling, avoiding any excess of the acid; precipitation by excess of alcohol; in the latter case the solution must be neutral or faintly acid. Hoppe-Seyler¹ recommends the employment of a saturated solution of freshly precipitated ferric oxide, in acetic acid.

Proteids may be very conveniently divided into Classes.

CLASS I. *Native Albumins.*

Members of this class, as their name implies, occur in a natural condition in animal tissues and fluids. They are soluble in water, are not precipitated by very dilute acids, by carbonates of the alkalis, or by sodium chloride. They are coagulated by heating to a temperature of about 70°. If dried at 40°, the resulting mass is of a pale yellow colour, easily friable, tasteless, and inodorous.

1. *Egg-albumin.*

Forms in aqueous solution a neutral, transparent, yellowish fluid. From this it is precipitated by excess of strong alcohol. If the alcohol be rapidly removed the precipitate may be readily redissolved in water; if

¹ *Op. cit.* p. 227.

subjected to lengthier action a coagulation occurs, and the albumin is then no longer thus soluble. Strong acids, especially nitric acid, cause a coagulation similar to that produced by heat or by the prolonged action of alcohol; the albumin becomes profoundly changed by the action of the acid and does not dissolve upon removal of the acid. Mercuric chloride, silver nitrate, and lead acetate, precipitate the albumin without coagulation; on removal of the precipitant the precipitate may be redissolved.

Strong acetic acid in excess gives no precipitate, but when the solution is concentrated transforms it into a transparent jelly. A similar jelly is produced when strong caustic potash is added to a concentrated solution of egg-albumin. In both these cases the substance is profoundly altered.

The specific rotatory power of egg-albumin in aqueous solution is, for yellow light, -35.5° . Hydrochloric acid, added until the reaction is strongly acid, increases this rotation to -37.7° . The formation of the gelatinous compound with caustic potash is at first accompanied with an increase, but this is followed by a decrease of rotation.

Preparation. White of hen's egg is broken up with scissors into small pieces, diluted with an equal bulk of water, and the mixture shaken strongly in a flask till quite frothy; on standing, the foam rises to the top, and carries all the fibres in whose meshwork the albumin was contained. The fluid, from which the foam has been removed, is strained, and treated carefully with dilute acetic acid as long as any precipitate is formed; the precipitate is then filtered off, and the filtrate after neutralisation concentrated at 40° to its original bulk.

2. *Serum-albumin.*

This form of albumin resembles, to a great extent, the one previously described. The following may suffice as distinguishing features.

1. The specific rotation of serum-albumin is -56° ; that of egg-albumin is -35.5° , both measured for yellow light.
2. Serum-albumin is not coagulated by ether, egg-albumin is.
3. Serum-albumin is not very readily precipitated by strong hydrochloric acid, and such precipitate as does occur is readily redissolved on further addition of the acid; the exact reverse of these two features holds good for egg-albumin.
4. Precipitated or coagulated serum-albumin is readily soluble, egg-albumin is with difficulty soluble, in strong nitric acid.

Serum-albumin is found not only in blood-serum, but also in lymph, both that contained in the proper lymphatic channels and that diffused in the tissues, in chyle, milk, transudations, and many pathological fluids.

It is this form which albumin generally assumes when it appears in the urine.

In addition to the above, Scherer¹ has described two closely related bodies, to which he gives the names Paralbumin and Metalbumin. The first he obtained from ovarian cysts; its alkaline solutions are remarkable for being veryropy. It seems doubtful whether this body is a proteid; it differs sensibly in composition from these. Haerlin² gives as its composition, O. 26.8, H. 6.9, N. 12.8, C. 51.8, S. 1.7 p. c. It seems to be associated with some body like glycogen, capable of being converted into a substance giving the reactions of dextrose. Metalbumin, found in a dropsical fluid, resembles the preceding, but is however not precipitated by hydrochloric acid, or by acetic acid and ferrocyanide of potassium; it is precipitated, but not coagulated, by alcohol; its solution is scarcely coagulated on boiling.

Albumins are generally found associated with small but definite amounts of saline matter. A. Schmidt³ says that they may be freed from these by dialysis, and that they are then not coagulated on boiling. From this it might be inferred that the albumin and the saline matters were peculiarly related, and that the latter played some special part during the coagulation of the former by heat. Schmidt's observations however have not been conclusively corroborated by subsequent observers.

CLASS II. *Derived Albumins (Albuminates).*

1. *Acid-albumin.*

When a native albumin in solution, such as serum-albumin, is treated for some little time with a dilute acid such as hydrochloric, its properties become entirely changed. The most marked changes are (1) that the solution is no longer coagulated by heat; (2) that when the solution is carefully neutralized the whole of the proteid is thrown down as a precipitate; in other words, the serum-albumin which was soluble in water, or at least in a neutral fluid containing only a small quantity of neutral salts, has become converted into a substance insoluble in water or in similar neutral fluids. The body into which serum-albumin thus becomes converted by the action of an acid is spoken of as *acid-albumin*. Its characteristic features are that it is insoluble in distilled water, and in neutral saline solutions, such as those of sodium chloride, that it is readily soluble in dilute acids or dilute alkalis, and that its solutions in acids or alkalis are not coagulated by boiling. When suspended, in the undissolved state, in water, and heated to 70°, it becomes coagulated, and is then undistinguishable from coagulated serum-albumin, or indeed from any other form of coagulated proteid. It is evident that the sub-

¹ *Ann. der Chem. und Pharm.* Bd. 82, p. 135.

² *Chem. Centralblatt*, 1862. No. 56.

³ *Pflüger's Archiv* xi. (1875), p. 1.

stance when in solution in a dilute acid is in a different condition from that in which it is when precipitated by neutralisation. If a quantity of serum- or egg-albumin be treated with dilute hydrochloric acid, it will be found that the conversion of the native albumin into acid-albumin is gradual; a specimen heated to 70° immediately after the addition of the dilute acid, will coagulate almost as usual; and another specimen taken at the same time will give hardly any precipitate on neutralisation. Some time later, the interval depending on the proportion of the acid to the albumin, on temperature, and on other circumstances, the coagulation will be less, and the neutralisation precipitate will be considerable. Still later the coagulation will be absent, and the whole of the proteid will be thrown down on neutralisation.

If finely-chopped muscle, from which the soluble albumins have been removed by repeated washing, be treated for some time with dilute (¼ per cent.) hydrochloric acid, the greater part of the muscle is dissolved. The transparent acid filtrate contains a large quantity of proteid material in a form which, in its general characters at least, agrees with acid-albumin. The acid solution of the proteid is not coagulated by boiling, but the whole of the proteid is precipitated on neutralisation; and the precipitate, insoluble in neutral sodium chloride solutions, is readily dissolved by even dilute acids or alkalis. The proteid thus obtained from muscle has been called *syntonin*, but we have at present no satisfactory test to distinguish the acid-albumin (or syntonin) prepared from muscle from that prepared from egg- or serum-albumin. When coagulated albumin or other coagulated proteid or fibrin is dissolved in strong acids, acid-albumin is formed; and when fibrin or any other proteid is acted upon by gastric juice, acid-albumin is one of the first products; and these acid-albumins cannot be distinguished from acid-albumin prepared from muscle or native albumin. Though hydrochloric acid is perhaps the most convenient acid for forming acid-albumin, other acids may also be used for the purpose of preparing it. Acid-albumin is soluble not only in dilute alkalis, but also in dilute solutions of alkaline carbonates; its solutions in these are not coagulated by boiling.

If sodium chloride in excess is added to an acid solution of acid-albumin, the acid-albumin is precipitated: this also occurs on adding sodium acetate or phosphate.

As special tests of acid-albumin may be given: 1. Partial coagulation of its solution in lime-water on boiling. 2. Further precipitation of the same solution after boiling, on the addition of calcium chloride, magnesium sulphate, or sodium chloride.

Dissolved in very dilute hydrochloric acid, acid-albumin (*syntonin*) prepared from muscle possesses a specific lævo-rotatory power of -72° for

yellow light, this being independent of the concentration¹. On heating the solution in a closed vessel in a water-bath, the rotatory power rises to -84.8° .

2. *Alkali-albumin.*

If serum- or egg-albumin or washed muscle be treated with dilute alkali instead of with dilute acid, the proteid undergoes a change quite similar to that which was brought about by the acid. The alkaline solution, when the change has become complete, is no longer coagulated by heat, the proteid is wholly precipitated on neutralisation, and the precipitate, insoluble in water and in neutral sodium chloride solutions, is readily soluble in dilute acids or alkalis. Indeed in a general way it may be said that acid-albumin and alkali-albumin are nothing more than solutions of the same substance in dilute acids and alkalis respectively. When the precipitate obtained by the neutralisation of a solution of acid-albumin in dilute acid is dissolved in a dilute alkali, it may be considered to become alkali-albumin; and conversely when the precipitate obtained from an alkali-albumin solution is dissolved in dilute acid, it may be regarded as acid-albumin.

A characteristic feature of this modified or derived albumin is that it is not precipitated when its alkaline solutions are neutralised in the presence of alkaline phosphates; the acid solutions on the contrary are precipitated on neutralisation in the presence of alkaline phosphates. Hence it is frequently said that acid-albumin is precipitated on neutralisation in the presence of alkaline phosphates, but that alkali-albumin is not.

Alkali-albumin may be prepared by the action not only of dilute alkalis but also of strong caustic alkalis on native albumins as well as on coagulated albumin and other proteids. The jelly produced by the action of caustic potash on concentrated white of egg, spoken of in Class I. 1, is alkali-albumin; the similar jelly produced by strong acetic acid is acid-albumin.

Both alkali- and acid-albumin are with difficulty precipitated by alcohol from their alkaline or acid solutions. The neutralisation precipitate however becomes coagulated under the prolonged action of alcohol.

The body 'protein,' for whose existence Mulder has so much contended, appears, if it exists at all, to be closely connected with this body. All subsequent observers have however failed to confirm his views.

The rotatory power of alkali-albumin varies according to its source; thus when prepared by strong caustic potash from serum-albumin, the rotation rises from -56° (that of serum-albumin) to -86° , for yellow light.

¹ Hoppe-Seyler, *Hdbk. Phys. Path. Chem. Anal.* p. 246.

Similarly prepared from egg-albumin, it rises from -35.5° to -47° , and if from coagulated white of egg, it rises to -58.8° . Hence the existence of various forms of alkali-albumin is probable.

In addition to the methods given above, alkali-albumin may be also readily obtained by shaking milk with strong caustic soda solution and æther, removing the ætherial solution, precipitating the remaining fluid with acetic acid and washing the precipitate with water, cold alcohol and æther.

The most satisfactory method of regarding acid- and alkali-albumin is to consider them as respectively acid and alkali compounds of the neutralisation precipitate. We have reason to think that when the precipitate is dissolved in either an acid or an alkali, it does enter into combination with them. The neutralisation precipitate is in itself neither acid- nor alkali-albumin, but may become either, upon solution in the respective reagent.

It is probable that several derived albumins exist, differing according to the proteid from which they are formed or possibly according to the mode of their preparation, and that each of these may exist in its correlative forms of acid- and alkali-albumin; but the whole subject requires further investigation.

Acid-albumin, prepared by the direct action of dilute acids on native albumins or on muscle-substance, contains sulphur, as shewn by the brown colouration which appears when the precipitate is heated with caustic potash in the presence of basic lead acetate. Alkali-albumin, at all events as prepared by the action of strong caustic potash or soda, does not contain any sulphur; and the acid-albumin, prepared by the solution in an acid of the neutralisation precipitate from such an alkali-albumin solution, is similarly free from sulphur.

3. *Casein.*

This is the well-known proteid existing in milk. When freed from fat, and in the moist condition, it is a white, friable, opaque body. In most of its reactions it corresponds closely with alkali-albumin; thus it is readily soluble in dilute acids and alkalis, and is re-precipitated on neutralisation; if, however, potassium phosphate is present, as is the case in milk, the solution must be strongly acid before any precipitate is obtained.

It is generally said to be distinguished from artificial alkali-albumin, by the following tests. 1. The latter if heated with caustic potash yields no sulphide of the alkali; casein does. 2. Casein digested with artificial gastric juice gives a body containing phosphorus, whereas an alkali-albumin containing no phosphorus can be prepared from white of egg.

Casein, as occurring in milk, has had several reactions ascribed to it, as characteristic; but these lose their importance on considering that milk contains, in addition to casein, other substances such as potassium phosphate, and a number of bodies which

yield acids by fermentation. The presence of potassium phosphate has an especial influence on the reaction of casein. In the entire absence of this salt, acetic acid in the smallest quantities, as also carbonic acid, gives a precipitate; but if this salt is present, carbonic acid gives no precipitate, and acetic acid one only when the solution is acid from the presence of free acid, and not from that of acid potassium phosphate¹.

When prepared from milk by magnesium sulphate (see below), freed by æther from fats, and dissolved in water, casein possesses a specific rotatory power of -80° for yellow light; in dilute alkaline solutions, of -76° ; in strong alkaline solutions, of -91° ; in dilute hydrochloric acid, of -87° .

Casein has been asserted to occur in muscle, in serous fluids, and in blood-serum. In many cases it has probably been confounded with globulin (see Class III.); but blood-serum and muscle-plasma undoubtedly contain an alkali-albumin in addition to whatever globulin may be present. Its presence may be shewn by adding dilute acetic acid to blood-serum which has been freed from globulin by a current of carbonic acid gas; a distinct precipitate is thrown down. A substance similar to casein has also been described as existing in unstriated muscle and in the protoplasm of nerve-cells.

Preparation. Dilute milk with several times its bulk of water, add dilute acetic acid till a precipitate begins to appear, then pass a current of carbonic acid gas, filter, and wash the precipitate with water, alcohol and æther. Magnesium sulphate added to saturation also precipitates casein from milk; as the precipitate thus formed is readily soluble on the addition of water.

CLASS III. *Globulins.*

Besides the native albumins there are a number of native proteids which differ from the albumins in not being soluble in distilled water; they need for their solution the presence of an appreciable, though it may be a small, quantity of a neutral saline body such as sodium chloride. Thus they resemble the albuminates in not being soluble in distilled water, but differ from them in being soluble in dilute sodium chloride or other neutral saline solutions. Their general characters may be stated as follows.

They are insoluble in water, soluble in dilute (1 p.c.) solutions of sodium chloride; they are also soluble in dilute acids and alkalis, being changed on solution into acid- and alkali-albumin respectively. The saturation with solid sodium chloride of their solutions in dilute sodium chloride, precipitates most members of this class.

1. *Globulin (Crystallin).*

If the crystalline lens be rubbed up with fine sand, extracted with water and filtered, the filtrate will be found to contain at least three

¹ See Kühne, *Lehrbuch*, p. 565.

proteids. On passing a current of carbonic acid gas a copious precipitate occurs; this is globulin.

The addition of dilute acetic acid to the filtrate from the globulin, gives a precipitate of alkali-albumin; and the filtrate from this if heated gives a further precipitate, due to serum-albumin.

In its general reactions globulin corresponds almost exactly with the next members of this class (paraglobulin and fibrinogen), but has no power to form or promote the formation of fibrin in fluids containing the above-mentioned bodies, and possesses the following special features. 1. According to Lehmann, its oxygenated, neutral solutions become cloudy on heating to 73°, and are coagulated at 93°. 2. It is readily precipitated on the addition of alcohol. According to Hoppe-Seyler, it is not precipitated on saturation with sodium chloride, resembling vitellin in this respect.

2. *Paraglobulin (Fibrinoplastin).*

Preparation. Blood-serum is diluted ten-fold with water, and a brisk current of carbonic acid gas is passed through it. The first-formed cloudiness soon becomes a flocculent precipitate, which is finally quite granular, and may easily be separated by decantation and filtration: it should be washed on the filter with water containing carbonic acid. It may also be separated from serum, by saturation with sodium chloride, or magnesium sulphate.

From its solution in dilute sodium chloride, it may be precipitated by a current of carbonic acid gas, or the addition of *exceedingly dilute* (less than 1 pro mille) acetic acid. If the acid is strong enough to dissolve the precipitated proteid, this becomes immediately changed into acid-albumin (Class II.). In pure water, free from oxygen, paraglobulin is insoluble, but on shaking with air or passing a current of oxygen, solution readily takes place; from this it may be re-precipitated by a current of carbonic acid gas. *Very dilute* alkalis dissolve this body without change; if, however, the strength of the alkali be raised even to 1 p. c. the paraglobulin is changed into alkali-albumin (Class II.).

According to Kühne and A. Schmidt the solutions of this body in water containing oxygen or in very dilute alkalis are not coagulated on heating. The sodium chloride solutions are however coagulable, and if the substance itself be suspended in water and heated to 70° it is coagulated. Although insoluble in alcohol, its solutions are with difficulty precipitated by this reagent.

A characteristic test for this body is that it gives rise to fibrin when added to many transudations, e.g. hydrocele, pericardial, peritoneal, and pleural fluids.

Paraglobulin occurs not only (and chiefly) in blood-serum, but it is also found in white corpuscles, in the stroma of red corpuscles (to some extent

at least), in connective tissue, cornea, aqueous humour, lymph, chyle, and serous fluids.

For the occurrence of globulin in urine, see Edlefsen¹ and Senator².

3. *Fibrinogen.*

The general reactions of this body are identical with those of paraglobulin. The characteristic test for its presence is the formation of fibrin when its solution is added to a solution known to contain paraglobulin and fibrin-ferment. Minor differences between the two may be thus enumerated:—In the preparation of fibrinogen, the containing fluid must be much more strongly diluted, and the current of carbonic acid gas must pass for a much longer time. The precipitate thus obtained differs from that of paraglobulin in that it forms a viscous deposit, adhering more closely to the sides and bottom of the containing vessel; there is also no flocculent stage previous to the viscous precipitate. The two also exhibit slight microscopical differences. Alcohol and æther both precipitate this body from its solution, but a mixture of the two (3 parts alcohol, 1 part æther) is most effectual.

Fibrinogen occurs in blood, chyle, serous fluids, and in various transudations.

Preparation. This is the same as for paraglobulin, regard being had to the peculiarities mentioned above.

There is no proof that the *whole* of the substance thrown down by carbonic acid from diluted blood-serum is fibrinoplastic. We know for certain (see p. 21) that the whole of the fibrinoplastic precipitate, used to cause the coagulation of a fibrinogenous fluid, does not enter into the composition of the fibrin produced; we also know that such a precipitate may lose its fibrinoplastic powers without any marked change in its general reactions. It would seem advisable therefore to speak of the deposit produced by carbonic acid in dilute serum, or by saturation with sodium chloride in undiluted serum, as globulin, and to distinguish it as fibrinoplastic globulin when it is able to give rise to fibrin. Fibrinogen similarly might be spoken of as fibrinogenous globulin. The name crystallin rather than globulin might then be given to the substance obtained from the crystalline lens.

4. *Myosin.*

This is the substance which forms the chief proteid constituent of dead, rigid muscle; its general properties and mode of preparation have been already described at p. 33. In the moist condition, it forms a gelatinous, elastic, clotted mass; dried, it is very brittle, slightly transparent and

¹ *Centralblatt f. d. med. Wiss.* 1870, p. 367. Also *Arch. f. klin. Med.* Bd. 7, p. 69.

² *Virchow's Archiv*, Bd. 60, p. 476.

elastic. From its solution in a sodium chloride solution it is precipitated, either by extreme dilution, or by saturation with the solid salt. The same solution, if exposed to a rising temperature, becomes milky at 55°, and gives a flocculent precipitate at 60°. This is however no longer myosin, for it is insoluble in a 10 p. c. sodium chloride solution, and does not, until after many days' digestion, yield syntonin on treatment with hydrochloric acid (·1 p. c.). It is in fact coagulated proteid (see Class V.). A similar coagulation occurs if the solid substance be suspended in water and heated to 70°.

Myosin is excessively soluble in dilute acids and alkalis, but undergoes in the act of solution a radical change, becoming in the one case acid-albumin or syntonin, in the other alkali-albumin (Class II.).

Like fibrin, it can in some cases decompose hydrogen dioxide, and oxidise guaiacum to a blue colour.

5. *Vitellin.*

As obtained from yolk of egg, of which it is the chief proteid constituent, vitellin is a white granular body, insoluble in water, but very soluble in dilute sodium chloride solutions; it surpasses myosin in this respect, for the solution may be easily filtered. Saturation with solid sodium chloride gives no precipitate; in this respect it differs from most other members of this class. In yolk of egg vitellin is always associated with, and probably exists in combination with, the peculiar complex body lecithin (see p. 609). From this it has not as yet been freed without coagulation occurring; hence probably we are unacquainted with it in its normal state.

Denis, and after him, Hoppe-Seyler, have shewn that vitellin before the treatment requisite to free it from lecithin, possesses properties quite different from other proteids.

A theory has been advanced that vitellin is really a complex body like hæmoglobin, and on treatment with alcohol splits up into coagulated proteid and lecithin. When well purified it contains ·75 p. c. sulphur, but no phosphorus. Dilute acids or alkalis readily convert it in its uncoagulated form into a member of Class II.

Fremy and Valenciennes¹ have described a series of proteids, viz. ichthin, ichthidin, &c., derived from fish and amphibia. They appear to be either identical with, or closely related to, vitellin.

Preparation. Yolk of egg is treated with successive quantities of æther, as long as this extracts any yellow colouring matter; the residue is dissolved in moderately strong (*ex. gr.* 5 p. c.) sodium chloride solution, and filtered. The filtrate on falling into a large excess of water is precipitated. In this state it is mixed with lecithin, and in order to free it from this,

¹ *Compt. Rend.* T. 38, p. 469 and 525.

it is usually treated with alcohol. This, as above stated, entirely changes the vitellin into a coagulated form.

6. *Globin.*

Globin, stated by Preyer¹ to be the proteid residue of the complex body hæmoglobin (see p. 279), ought probably to be considered as an outlying member of this class. It is however not readily soluble either in dilute acids or sodium chloride solutions. It is remarkable for being absolutely free from ash.

CLASS IV. *Fibrin.*

Insoluble in water and dilute sodium chloride solutions; soluble with difficulty in dilute acids and alkalis, and more concentrated neutral saline solutions.

Fibrin, as ordinarily obtained, exhibits a filamentous structure, the component threads possessing an elasticity much greater than that of any other known solid proteid.

If allowed to form gradually in large masses, the filamentous structure is not so noticeable, and it resembles in this form pure indiarubber. Such lumps of fibrin are capable of being split in any direction, and no definite arrangement of parallel bundles of fibres can be made out.

At ordinary temperatures fibrin is insoluble in water, being dissolved only at very high temperatures, and then undergoing a complete change in its characters. In hydrochloric acid solutions of 1—5 p. c. fibrin swells up and becomes transparent, but is not dissolved². In this condition the mere removal of the acid by an excess of water, neutralisation, or the addition of some salt, causes a return to the original state. If, however, the acid be allowed to act for many days at ordinary temperatures or for a few hours at 40°—60°, solution takes place, and the resulting proteid is syntonin. In dilute alkalis and ammonia, fibrin is much more readily soluble, though in this case also the solution is greatly aided by warming; the resulting fluid contains no longer fibrin, but alkali-albumin. This property is not distinctly characteristic of fibrin, although it dissolves perhaps more readily in both dilute acids and alkalis than do coagulated proteids. None of these solutions can be coagulated on heating, which is intelligible when it is remembered that they no longer contain fibrin, but either acid- or alkali-albumin. In addition to the above, fibrin is soluble, though with difficulty and only after a considerable time, in 10 p. c. solutions of sodium chloride, potassium nitrate or sodium sulphate. These solutions may be coagulated by a temperature of 60°; in fact, by the action of the neutral saline solutions the fibrin has become converted into a body exceedingly like myosin or globulin.

¹ *Blutkrystalle* (1871) p. 166.

² Complete solution may however take place if the fibrin contain pepsin. See note, p. 221.

On ignition of fibrin a residue of inorganic matter is always obtained; it is, however, considered that sulphur is the only one of these elements which enters essentially into its composition. In other respects fibrin corresponds entirely in general composition with other proteids.

Suspended in water and heated to 70°, it loses its elasticity, and becomes opaque; it is then indistinguishable from other coagulated proteids.

A peculiar property of this body remains yet to be mentioned, viz. its power of decomposing hydrogen dioxide. Pieces of fibrin placed in this fluid, though themselves undergoing no change, soon become covered with bubbles of oxygen; and guaiacum is turned blue by fibrin in presence of hydrogen dioxide or ozonised turpentine. In the language of Schönbein's theory fibrin is an ozone-bearer.

Preparation. Either by washing blood-clots, or whipping blood with a bundle of twigs and then washing. If required quite colourless it should be prepared from plasma free from corpuscles.

When globulin, myosin, and fibrin are compared with each other, it will be seen that they form a series in which myosin is intermediate between globulin and fibrin. Globulin is excessively soluble in even the most dilute acids and alkalis; fibrin is almost insoluble in these; while myosin, though more soluble than fibrin, is less soluble than globulin. Globulin again dissolves with the greatest ease in a very dilute solution of sodium chloride. Myosin, on the other hand, dissolves with difficulty; it is much more soluble in a 10 per cent. than in a one per cent. solution of sodium chloride; and even in a 10 per cent. solution the myosin can hardly be said to be dissolved, so viscid is the resulting fluid and with such difficulty does it filter. Fibrin again dissolves with great difficulty and very slowly in even a 10 per cent. solution of sodium chloride, and in a one per cent. solution it is practically insoluble. When it is remembered that fibrin and myosin are, both of them, the results of coagulation, their similarity is intelligible. Myosin is in fact a somewhat more soluble form of fibrin, deposited not in threads or filaments but in clumps and masses.

CLASS V. *Coagulated Proteids.*

These are insoluble in water, dilute acids and alkalis, and neutral saline solutions of all strengths. In fact they are really soluble only in strong acids and strong alkalis, though prolonged action of even dilute acids and alkalis will effect some solution, especially at high temperatures. During solution in strong acids and alkalis a destructive decomposition takes place, but some amount of acid- or alkali-albumin is always produced.

Very little is known of the chemical characteristics of this class. They are produced by heating to 70°, solutions of egg- or serum-albumin, globulins suspended in water or dissolved in saline solutions, fibrin sus-

pended in water or dissolved in saline solutions, or precipitated acid- and alkali-albumin suspended in water. They are readily converted at the temperature of the body into peptones, by the action of gastric juice in an acid, or of pancreatic juice in an alkaline medium.

CLASS VI. *Peptones.*

Very soluble in water, and not precipitated from their aqueous solutions by the addition of acids or alkalis, or by boiling. Insoluble in alcohol, they are precipitated with difficulty by this reagent, and are unchanged in the process; they differ from all other proteids in not being coagulated by exposure to alcohol. They are not precipitated by cupric sulphate, ferric chloride, or, except in the instances to be mentioned presently, by potassium ferrocyanide, and acetic acid. In these points they differ from most other proteids. On the other hand, precipitation is caused by chlorine, iodine, tannin, mercuric chloride, nitrates of mercury and silver, and both acetates of lead; also by bile-acids in an acid solution. In common with all proteids, these bodies possess a specific lævo-rotatory power over polarised light; but they differ from all other proteids in the fact that boiling produces no change in the amount of rotation.

A solution of peptones, mixed with a strong solution of caustic potash, gives, on the addition of a mere trace of cupric sulphate, a red colour. An excess of the cupric salt gives a violet colour, which deepens in tint on boiling. Other proteids simply give the violet colour. But the most characteristic feature of peptones is their extreme diffusibility, a property which they alone, of all the proteids, may be said to possess, since all other forms of proteids pass through membranes with the greatest difficulty, if at all.

Notwithstanding their probable formation in large quantities in the stomach and intestine, to judge from the result of artificial digestion, a very small quantity only can be found in the contents of these organs, or in the chyle. They are probably absorbed as soon as formed. Another point of interest is their reconversion into other forms of proteids, since this must occur to a great extent in the body. We are however unacquainted with any processes able to effect this reverse change.

Production. All proteids, with the exception of lardacein, yield peptones (and other products) on treatment with acid gastric or alkaline pancreatic juice, most readily at the temperature of the human body. Peptones are likewise produced, in the absence of pepsin and trypsin, by the action of dilute and moderately strong acids at medium temperatures, also by the action of distilled water at very high temperatures and great pressure. For various methods of preparing peptones, see Adamkiewicz¹.

¹ *Die Natur u. Nährwerth d. Peptons* (1877), p. 33.

No exact difference in percentage composition between peptones and the proteids from which they are formed has, at present, been established.

We have used the phrase 'peptones' in the plural number because we have reason to think that more than one kind of peptone exists. Meissner¹ described three peptones, naming them respectively A- B- and C-peptone. He distinguished them as follows. A-peptone is precipitated from its aqueous solutions by concentrated nitric acid, and also by potassium ferrocyanide in the presence of even weak acetic acid. B-peptone is not precipitated by concentrated nitric acid, nor will potassium ferrocyanide give a precipitate unless a considerable quantity of strong acetic acid be added at the same time. C-peptone is precipitated neither by nitric acid nor by potassium ferrocyanide and acetic acid, whatever be the strength of the acetic acid. In place however of speaking of all these as peptones, it is better to consider C-peptone as the only real peptone, and the A- and B-peptones as not peptones at all. Nevertheless we have reason, from the researches of Kühne, to speak of more than one peptone, *viz.* of a hemipeptone which is capable under the action of trypsin of being converted into leucin and tyrosin, and of an antipeptone which resists such a decomposition. The name antipeptone is given to the latter on account of this resistance which it offers towards trypsin; the name hemipeptone, given to the former, signifies that this peptone is the twin or correlative half of antipeptone.

We have seen (p. 191) that when any proteid is digested with pepsin, what we may preliminarily call a bye-product makes its appearance. This bye-product, which has many resemblances to acid-albumin or syntonin, appearing as a neutralisation precipitate soluble in dilute acids and alkalis but insoluble in distilled water, is generally spoken of as parapeptone. According to Finkler² this neutralisation precipitate is especially abundant if the pepsin be previously modified by exposure to a temperature of 40° to 60° C. The pepsin thus modified is spoken of by Finkler as 'isopepsin.' Many authors regard parapeptone, syntonin, and acid-albumin as being the same thing. Meissner however gave the name parapeptone to a body, which need not and probably does not make its appearance during normal natural digestion or during artificial digestion with a thoroughly active pepsin, but which is formed when proteids are subjected to the action of weak hydrochloric acid, either alone or in company with an imperfectly-acting pepsin, and which in certain characters is quite distinct from ordinary syntonin or acid-albumin. Its distinguishing feature is that it cannot be changed into peptone by the action of even the most energetic pepsin, though it is readily so con-

¹ *Zeitschr. f. Rat. Med.*, Bde. VII., VIII., X., XII. and XIV.

² *Pflüger's Archiv*, XIV. (1877) p. 128.

verted under the influence of trypsin; otherwise it very closely resembles syntonin. We have here an indication that the simple characters by which we have described acid-albumin may be borne by bodies having marked differences from each other. The researches of Kühne, to which we have briefly referred in the text (p. 202), have thrown an important light on these differences. The fundamental notion of Kühne's view is that an ordinary native albumin or fibrin contains within itself two residues, which he calls respectively an anti-residue and a hemi-residue. The result of either peptic or tryptic digestion is to split up the albumin or fibrin, and to produce on the part of the anti-residue antipeptone, and on the part of the hemi-residue hemipeptone, the latter being distinguished from the former by its being susceptible of further change by tryptic digestion into leucin, tyrosin, &c. Antipeptone remains as antipeptone even when placed under the action of the most powerful trypsin, provided putrefactive changes do not intervene.

Before the stage of peptone (whether anti- or hemi-) is reached, there is an intermediate stage corresponding to the formation of syntonin. In both normal peptic and tryptic digestion antipeptone is preceded by an anti-albumose, and hemipeptone by a hemi-albumose. Of these the anti-albumose is closely related to syntonin, and has hitherto been regarded as syntonin. The hemi-albumose has not been so frequently observed; it was however isolated by Meissner; it is apparently the body called by him A-peptone. It possesses a peculiar feature in being soluble at about 70° C., and being re-precipitated on cooling; in this respect it closely resembles a proteid body observed by Bence-Jones in the urine of osteomalacia. It approaches myosin in being readily soluble in a 10 per cent. solution of sodium chloride.

If however albumin be digested with insufficient or with imperfectly acting pepsin, or simply with dilute hydrochloric acid at 40°, anti-albumose is not formed, but in its place a body makes its appearance which Kühne calls anti-albumate¹. Its characteristic property is that it cannot be converted by peptic digestion into peptone, though it can be so changed by tryptic digestion. It is in fact the parapeptone of Meissner.

It may perhaps be advisable, now that Meissner's parapeptone is cleared up, to reserve the name parapeptone for the initial products of both peptic and tryptic digestion, to speak of anti-albumose and hemi-albumose as being both parapeptones. But in this sense parapeptone will be an intermediate and not a collateral product of digestion.

Meissner also described a particularly insoluble form of his parapeptone as dyspeptone, and another intermediate product as metapeptone; but further investigation of both these bodies, as well as of his B-peptone,

¹ An albumate must not be confounded with an albuminate.

is necessary. Under the influence of dilute hydrochloric acid, anti-albumate becomes changed into a body which Kühne calls anti-albumid and which seems identical with the very insoluble proteid described by Schützenberger as 'hemiprotein,' and probably with Meissner's dyspeptone. The same body is produced at once in company with products belonging to the hemi-group by the action of 3 to 5 per cent. sulphuric acid on native albumin or fibrin. The following table shews the relations and genesis of the bodies we have just described. The several products (antipeptone, &c.) are given in duplicate, on the hypothesis (which though not proved is probable) that the changes of digestion are essentially hydrolytic changes, accompanied by a deduplication. That just as a molecule of starch splits up into at least two molecules of dextrose, or as a molecule of cane-sugar splits up into a molecule of dextrose and a molecule of levulose, so a molecule of antialbumose, for instance, splits up into two molecules of antipeptone, and so on. But the whole scheme is of course only provisional.

DECOMPOSITION OF PROTEIDS BY DIGESTION.

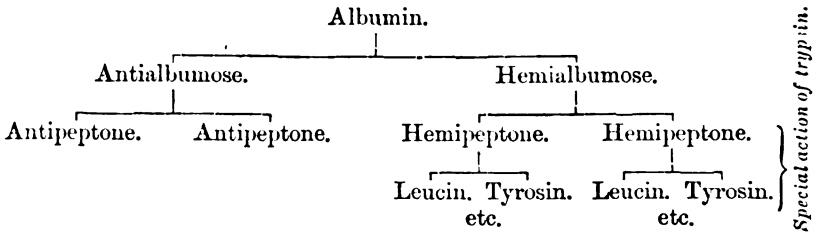

DECOMPOSITION BY ACIDS.

1.

By .25 p. c. HCl at 40° C.

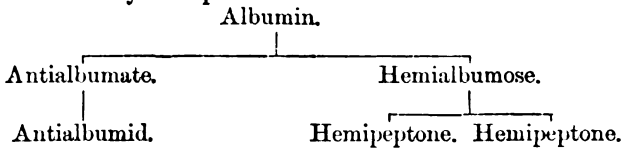

2.

By 3—5 p. c. H₂SO₄ at 100° C.

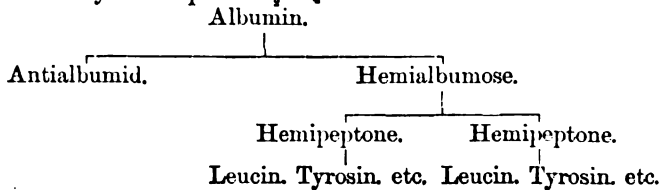

CLASS VII. *Lardacein, or the so-called amyloid substance.*

The substance to which the above name is applied, is found as a deposit in the spleen and liver, also in numerous other organs, such as the blood-vessels, kidneys, lungs, &c.

It is insoluble in water, dilute acids and alkalis, and neutral saline solutions.

In centesimal composition it is almost identical with other proteids', viz. :—

O. and S.	H.	N.	C.
24·4	7·0	15·0	53·6

The sulphur in this body exists in the oxidised state, for boiling with caustic potash gives no sulphide of the alkali. The above results of analysis would lead at once to the ranking of lardacein as a proteid, and this is borne out by other facts. Strong hydrochloric acid converts it into acid-albumin, and caustic alkalis into alkali-albumin. On the other hand, it exhibits the following marked differences from other proteids:—It wholly resists the action of ordinary digestive fluids; it is coloured red, not yellow, by iodine, and violet or pure blue by the joint action of iodine and sulphuric acid. From these last reactions it has derived one of its names, 'amyloid,' though this is evidently badly chosen. Not only does it differ from the starch group in composition, but by no means can it be converted into sugar: this latter is one of the crucial tests for a true member of the amyloid group. According to Heschl¹ and Cornil² anilin-violet (methyl-anilin) colours lardaceous tissue rosy red, but sound tissue blue.

The colours mentioned above, as being produced by iodine and sulphuric acid, are much clearer and brighter when the reagents are applied to the purified lardacein. When the reagents are applied to the crude substance in its normal position in the tissues, the colours obtained are always dark and dirty-looking.

Purified lardacein is readily soluble in moderately dilute ammonia, and can, by evaporation, be obtained from this solution in the form of tough, gelatinous flakes and lumps; in this form it gives feeble reactions only with iodine. If the excess of ammonia is expelled, the solution becomes neutral, and is precipitated by dilute acids.

Preparation. The gland or other tissue containing this body, is cut up into small pieces, and as much as possible of the surrounding tissue removed. The pieces are then extracted several times with water and dilute alcohol, and if not thus rendered colourless, are repeatedly boiled with alcohol containing hydrochloric acid. The residue after this operation

¹ C. Schmidt, *Ann. d. Chem. u. Pharm.* Bd. 110, p. 250, and Friedreich and Kekulé, *Virchow's Archiv*, Bd. 16, p. 50.

² *Wien. med. Wochenschr.* No. 82, p. 714.

³ *Compt. Rend.* May 24, 1875.

is digested at 40°, with good artificial gastric juice in excess. Everything except lardacein, and small quantities of mucin, nuclein, keratin, together with some portion of the elastic tissue, will thus be dissolved and removed¹. From the latter impurity it may be separated by decantation of the finely-powdered substance.

The chief products of the decomposition of proteids are ammonia, carbonic acid, leucin and tyrosin. Several other bodies, for the most part, like leucin, amidated acids, such as aspartic acid, glutamic acid, &c., have also been obtained. But urea has never yet been derived by direct decomposition from proteid material, the statements to this effect having been based on errors. In spite of numerous researches, we cannot at present state definitely what is the real constitution of a proteid, or in what manner these several residues are contained in the undecomposed substance. It is unnecessary to give here any of the formulæ, nearly all empirical, which have been made to represent these bodies; they all give with equal exactitude the percentage composition, but beyond this they are untrustworthy. Of the various attempts which have been made to assign to proteids some definite molecular structure, none appear, at the present stage of information, sufficiently reliable for general acceptance.

Among the most elaborate labours in this direction may be mentioned those of Hlasiwetz and Haberman. In their first publication², starting from the general similarity of the products of decomposition of the proteids and carbohydrates, they tried to establish a definite relation between the two classes of bodies. In this they were not successful, and from their second research³ they come to the conclusion that the carbohydrates take no part in the formation of the proteids.

Other experiments in the same direction are due to Schützenberger⁴. He shews that albumin can be decomposed into carbonic anhydride and ammonia, and that the ratio of these two is the same as though urea had been the body on which he operated. From this he concludes that "the molecule of albumin contains the grouping of urea and represents a complex ureide." In his second publication⁵ he confirms his previous results, stating that the ammonia, carbonic anhydride and oxalic acid, produced by the decomposition of proteids, are so connected quantitatively as to be capable of derivation from varying proportions of urea and oxamide. He also obtained from the decomposition of proteids a nitrogenous residue which could be formulated as giving rise to all the amidated acids and other bodies spoken of above. Thus according to him, albumin, built up as a complex ureide, decomposes into ammonia, carbonic, oxalic, and acetic acids, and this nitrogenous body: this last then gives rise to the other products of decomposition.

It will be noticed that in the general description of the various proteids, distinctive reactions for each could not be given, but that varying

¹ Kühne, *Virchow's Arch.* Bd. 83.

² *Ann. d. Chem. u. Pharm.* Bd. 159, p. 304.

³ *Ibid.* Bd. 169, p. 150.

⁴ *Comptes Rendus*, T. 80, p. 232.

⁵ *Ibid.* T. 81, p. 1108.

NITROGENOUS NON-CRYSTALLINE BODIES ALLIED TO PROTEIDS.

These resemble the proteids in many general points, but exhibit among themselves much greater differences than the proteids do. As regards their molecular structure nothing satisfactory is known. Their percentage composition approaches that of the proteids, and like these they yield, under hydrolytic treatment, large quantities of leucin and in some cases tyrosin. They are all amorphous.

Mucin. (O, 35.75. H, 6.81. N, 8.50. C, 48.94)¹.

The characteristic component of mucus. Its exact composition is not yet known, the figures given above being merely an approximation.

As occurring in the normal condition it gives to the fluids which contain it the well-known ropy consistency, and can be precipitated from these by acetic acid, alcohol, alum and mineral acids; the latter, if in excess, redissolve the precipitate, but this is not the case with acetic acid. In its precipitated form it is insoluble in water, but swells up strongly in it, and this effect is increased by the presence of many alkali salts. Alkalis and alkaline earths dissolve it readily. Its solutions do not dialyse; they give the proteid reactions with Millon's reagent and nitric acid, but none with sulphate of copper, and are precipitated by basic lead acetate only when neutral or faintly alkaline. According to Eichwald², when heated with dilute mineral acids, mucin yields acid-albumin, and another body which in many of its properties closely resembles a sugar; it reduces solutions of cupric sulphate. Prolonged boiling with sulphuric acid gives leucin and about 7 p.c. of tyrosin.

Preparation. From ox-gall, by precipitation with alcohol, redissolving in water and precipitating with acetic acid. It is readily obtained from any of its solutions, by the addition of acetic acid.

Chondrin. (O, 31.04. H, 6.76. N, 13.87. C, 47.74. S, .60 p.c.)³.

This is usually regarded as forming the essential part of the matrix of hyaline cartilage, and is contained in the interstices of the fibres in elastic cartilage. A similar substance can be prepared from the cornea. Boiled with water, it dissolves slowly, forming an opalescent solution, which is precipitated by acetic acid, lead acetate, dilute mineral acids, alum, and salts of silver and copper; an excess of the last four reagents redissolves the precipitate. Solutions of this body gelatinise on standing, even if very dilute; the solid mass is insoluble in cold water, readily soluble in hot water, alkalis and ammonia.

¹ Eichwald, *Ann. d. Chem. u. Pharm.* Bd. 134, p. 193.

² *Op. cit.*

³ I. v. Mering, *Beitrag zur Chemie des Knorpels*, 1873.

The aqueous and alkaline solutions of chondrin possess a left-handed rotatory power on polarised light of -213.5° ; in presence of excess of alkali this becomes -552.0° , both measured for yellow light.

It seems, according to the observations of many, that chondrin can, by heating with hydrochloric acid, be converted into a body whose reactions resemble those of syntonin, and another substance, which like the similar product from mucin, so far resembles grape sugar that it reduces cupric salts in alkaline solution¹; it appears however to contain nitrogen. A recent observer² has denied the existence of chondrin as a distinct substance and regards it as in all cases a mere mixture of other bodies. He states that a substance having all the reactions of the so-called chondrin, may at any time be produced by a mixture of mucin, gluten and inorganic salts. The extreme similarity in the reactions of chondrin and mucin point to a close relationship between the two. The whole subject, however, requires more complete investigation. With alkalis or dilute sulphuric acid chondrin gives leucin, but no tyrosin or glycocholl. Whether chondrin exists as such in cartilage is uncertain; it seems probable that it does not, since its extraction from cartilage requires an amount of boiling with water much greater than that requisite to dissolve dried chondrin.

Preparation. From cartilage by extracting with water, and precipitating with acetic acid.

Glutin or Gelatin. (O, 23.21. H, 7.15. N, 18.32. C, 50.76. S, .56 p.c.)

This is the substance which is yielded when connective tissue fibres are heated for several days with very dilute acetic acid, at a temperature of about 15° C, or when they are treated with water in a digester. The elastic elements of connective tissue are unaffected by the above treatment.

As obtained in this way gluten is when heated a thin fluid, solidifying on cooling to the well-known gelatinous form. When dried it is a colourless, transparent, brittle body, swelling up in cold water, but remaining undissolved; heating, or the addition of traces of acids or alkalis, readily effects its solution. When dissolved in water it possesses a levorotatory power of -130° , at 30° C.; the addition of strong alkali or acetic acid reduces this to -112° or -114° , both measured for yellow light³. Its solutions will not dialyse.

Mercuric chloride and tannic acid are the only two reagents which yield insoluble precipitates with this body. Its presence prevents the action of

¹ De Bary, Hoppe-Seyler's *Untersuch.* Hft. I. p. 71.

² Morochowetz, *Verhand. Naturhist. Med. Ver. Heidelberg.* Bd. I. Hft. 5.

³ Hoppe-Seyler, *Hdbk.* p. 222.

Trommer's sugar test, since it readily dissolves up the precipitated cuprous oxide. The proteid reactions of glutin are so feeble that they are probably due merely to impurities. Heated with sulphuric acid it yields ammonia, leucin and glycocoll, but no tyrosin.

It appears improbable that glutin exists ready formed in connective tissue fibres, since these do not swell up in water, and only yield glutin after prolonged treatment with boiling water; to which it may be added that while glutin is acted upon by trypsin, the connective tissue fibres in their natural condition resist its action (see p. 203).

Elastin. (O, 20.5. H, 7.4. N, 16.7. C, 55.5 p.c.)

This characteristic component of elastic fibres is left on the removal of all the glutin, mucin, &c. from such tissues as "ligamentum nuchæ," advantage being taken of its not being altered when it is heated with water, even under pressure, with strong acetic acid, or with dilute alkalis. When moist it is yellow and elastic, but on drying becomes brittle. It is soluble in strong alkalis at boiling temperatures; concentrated sulphuric and nitric acids however dissolve it in the cold. It is precipitated from solutions by tannic acid, but not by the addition of ordinary acids. Notwithstanding that it closely approaches the proteids in its percentage composition, and gives distinct although feeble proteid reactions, any very close relationship between the two appears improbable, since elastin when treated with sulphuric acid, yields leucin (30—40 p.c.) only and no tyrosin.

Hilger¹ has obtained a similar body from the shell membrane of snakes' eggs.

Keratin. (O, 20.7—25.0. H, 6.4—7.0. N, 16.2—17.7. C, 50.3—52.5. S, .7—5.0 p.c.)

This body, though somewhat resembling the proteids in general composition, differs from them and also from the preceding bodies so widely in other properties, that its description is placed here for convenience rather than anything else. Hair, nails, feathers, horn, and epidermic scales consist for the most part of keratin. Heated with water in a digester at 150° keratin is partially dissolved with evolution of sulphuretted hydrogen; the solution then gives with acetic acid and ferrocyanide of potassium a precipitate soluble in excess of the acid. Prolonged boiling with alkalis and acids, even acetic, dissolves keratin; the alkaline solutions evolve sulphuretted hydrogen on treatment with acids. The sulphur in keratin is evidently very loosely united to the substance, and in all its reactions there appears to be a want of similarity between keratin and either proteids, mucin or gelatin. The most common of its products of decomposition are leucin

¹ *Ber. d. deutsch. chem. Gesellsch.* 1873, p. 166.

(10 p.c.), and tyrosin (3.6 p. c.), and some aspartic acid; no glycine is formed. What is generally known as keratin is probably a compound body, which has not yet been resolved into its components.

Ewald and Kühne¹ have described a new body to which, since it occurs as a constituent of nervous tissue (both of nerves and of the central nervous system), and is yet closely identical with ordinary horny tissue, they give the name of neuro-keratin. It is prepared in quantity from the brain by extracting this tissue with alcohol and æther, and subjecting the residue to the action of pepsin and trypsin. The final residuum is neuro-keratin, and amounts to 15—20 p. c. of the original tissue.

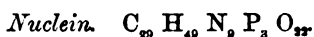

Discovered by Miescher² in the nuclei of pus corpuscles and in the yellow corpuscles of yolk of egg. Other observers have subsequently obtained it from yeast, from semen, from the nuclei of the red blood-corpuscles of birds and amphibia, from hepatic cells, and it is probably present in all nuclei.

When newly prepared it is a colourless amorphous body, soluble to a slight extent in water, readily soluble in many alkaline solutions; but its solubilities alter on keeping. If added gradually in sufficient quantity to a solution of caustic alkali it first neutralises the solution and then renders it acid. It seems to possess an indistinct xanthoproteic reaction, but gives no reaction with Millon's fluid. It yields precipitates with several salts, e. g. zinc chloride, silver nitrate, and cupric sulphate.

Preparation. This is difficult, since nuclein is easily decomposed³. The most remarkable feature of this body is its large percentage of phosphorus, 9.59 per cent. This phosphorus is readily separated by boiling with strong hydrochloric acid or caustic alkalis; the same occurs when solutions of nuclein are acidulated and allowed to stand.

CARBOHYDRATES.

Certain members only of this class occur in the human body; of these, the most important and wide spread is that known as grape-sugar, or dextrose (glucose), with which diabetic sugar seems to be identical⁴. Next to this comes milk-sugar. Inosit is another body of this class, although it differs in many important points from the preceding two.

¹ *Verhand. Naturhist. Med. Ver. Heidelberg.* Bd. 1. Heft 5.

² *Med. Chem. Untersuch.* Hoppe-Seyler, Heft 4, 1872, pp. 441 and 502.

³ Miescher, *Op. cit.*

⁴ The question, however, whether several varieties of sugar occurring in the animal body have not been confounded together under the common name of dextrose or glucose may be considered at present an open one.

Glycogen belongs properly to the sub-class of carbohydrates known as starches.

These bodies are often considered to be polyatomic alcohols. Several of them stand in peculiar relation to mannit, and may be converted into that substance by the action of sodium amalgam¹.

1. *Dextrose* (Grape-sugar). $C_6H_{12}O_6 + H_2O$.

Occurs in the contents of the alimentary canal to a variable extent dependent on the nature of the food taken. It is also a normal constituent of blood, chyle, and lymph. Concerning its presence in the liver, see p. 333. The amniotic fluids also contain this body. Bile in the *normal* condition is free from sugar, so also is urine, though this point has given rise to great dispute². The disease diabetes is characterised by an excess of dextrose in the tissues and fluids of the body (see p. 337).

When pure, dextrose is colourless and crystallises in four-sided prisms, often agglomerated into warty lumps. The crystals will dissolve in their own weight of cold water, requiring however some time for the process; they are very readily soluble in hot water. Dextrose is soluble in alcohol, but insoluble in æther.

The freshly prepared cold aqueous solution of the crystals possesses a dextro-rotatory power of $+104^\circ$ for yellow light. This, quickly on heating, more slowly on standing, falls to $+56^\circ$, at which point it remains constant.

Dextrose readily forms compounds with acids and bases; the latter are very unstable, decomposition rapidly ensuing on heating them. When its metallic compounds are decomposed the decomposition is in many cases accompanied by the precipitation of the metals, *e.g.* silver, gold, mercury, bismuth. Caustic alkalis readily decompose it, as also does ammonia.

Dextrose is readily and completely precipitated by lead acetate and ammonia.

An important property of this body is its power of undergoing fermentations. Of these the two principal are: (1) *Alcoholic*. This is produced in aqueous solutions of dextrose, under the influence of yeast. The decomposition is the following: $C_6H_{12}O_6 = 2C_2H_5O + 2CO_2$, yielding (ethyl) alcohol and carbonic anhydride. Other alcohols of the acetic series are found in traces, as also are glycerine, succinic acid and probably many other bodies. The fermentation is most active at about $25^\circ C$. Below 5° or above 45° it almost entirely ceases. If the saccharine solution contains more than 15 per cent. of sugar it will not all be decomposed, as excess of alcohol stops the reaction. (2) *Lactic*. This occurs in the presence of decomposing nitrogenous matter, especially of casein, and is probably the result of the action of a specific ferment. The first stage is the production of lactic acid,

¹ Linnemann, *Ann. d. Chem. u. Pharm.* Bd. 123, p. 136.

² See Seegen, *Der Diabetes Mellitus*, 2 Ed. p. 196.

$C_6H_{12}O_6 = 2C_3H_6O_3$. In the second butyric acid is formed with evolution of hydrogen and carbonic anhydride: $2C_3H_6O_3 = C_4H_8O_2 + 2CO_2 + 2H_2$. The above changes, the first of which is probably undergone by sugar to a considerable extent in the intestine, are most active at 35° ; the presence of alkaline carbonates is also favourable. It is moreover essential that the lactic acid should be neutralised as fast as it is formed, otherwise the presence of the free acid stops the process.

The detection and estimation of dextrose are so fully given in various books that they need not be detailed here.

2. Milk-sugar. $C_{12}H_{22}O_{11} + H_2O$.

Also known as *lactose*. It is found in milk, and is the only sugar which enters into the composition of this secretion.

It yields, when pure, hard colourless crystals, belonging to the rhombic system (four or eight-sided prisms). It is less soluble in water than dextrose, requiring for solution six times its weight of cold, but only two parts of boiling water; it is entirely insoluble in alcohol and æther. It is fully precipitated from its solutions by the addition of lead acetate and ammonia.

When freshly dissolved, its aqueous solution possesses a specific dextro-rotatory power of $+93.1^\circ$ for yellow light: this diminishes, slowly on standing, rapidly on boiling, until it finally remains constant at $+59.3^\circ$. The amount of rotation is independent of the concentration of the solution.

Lactose unites readily with bases, forming unstable compounds; from its metallic compounds the metal is precipitated in the reduced state on boiling; it reduces copper salts as readily as dextrose.

Lactose is generally stated to admit of no direct alcoholic fermentation; this may however sometimes be induced by a lengthy action of yeast. By boiling with dilute mineral acids lactose is converted into galactose, which readily undergoes alcoholic fermentation.

Galactose is very readily soluble in water, though insoluble in alcohol. It possesses a higher rotatory power than lactose, viz. $+83.2^\circ$; in a freshly prepared solution the rotation is $+139.6^\circ$. It may be remarked here that though *isolated* lactose is incapable of direct alcoholic fermentation, milk itself may be fermented; Berthelot was unable in this direct alcoholic fermentation to detect any intermediate change of the lactose into another fermentable sugar.

Lactose is however *directly* capable of undergoing the lactic fermentation; the circumstances and products are the same as in the case of dextrose (see above). The action is generally productive of a collateral small quantity of alcohol.

The tests for the presence of this body are the same as for dextrose, with the exception of the alcoholic fermentation.

Preparation—After the removal of the casein and other proteids of the milk, the mother liquor is evaporated to the crystallising point; the crystals are purified by repeated crystallisation from warm water.

3. *Inosit.* $C_6H_{12}O_6 + 2H_2O$.

This substance occurs but sparingly in the human body; it was found originally by Scherer¹ in the muscles of the heart. Cloetta shewed its presence in the lungs, kidneys, spleen and liver², and Müller in the brain³. It occurs also in diabetic urine, and in that of 'Bright's disease,' and is found in abundance in the vegetable kingdom.

Pure inosit forms large efflorescent crystals (rhombic tables); in microscopic preparations it is usually obtained in tufted lumps of fine crystals. Easily soluble in water, it is insoluble in alcohol and æther. It possesses no action on polarised light, and does not reduce solutions of metallic salts.

It admits of no direct alcoholic, but is capable of undergoing the lactic fermentation; according to Hilger⁴ the acid formed is sarcolactic. It is unaltered by heating with dilute mineral acids.

Preparation. It may be precipitated from its solutions by the action of basic lead acetate and ammonia.

As a special test may be mentioned the production of a bright violet colour by careful evaporation to dryness on platinum foil, with a little ammonia and calcium chloride.

4. *Glycogen.* $C_6H_{10}O_5$.

Belongs to the starch division of carbohydrates. Discovered by Bernard in the liver and other organs (see p. 330).

Glycogen is, when pure, an amorphous powder, colourless and tasteless, readily soluble in water, insoluble in alcohol and æther. Its aqueous solution is generally though not always strongly opalescent, but contains no particles visible microscopically; the opalescence is much reduced by the presence of free alkalis. The same solution possesses, according to Hoppe-Seyler, a very strong dextro-rotatory power; it dissolves hydrated cupric oxide; but this is not reduced on boiling.

By the action of dilute mineral acids (except nitric) it is converted into dextrose, and the same conversion is also readily effected by the action of amyolytic ferments. It is not affected by boiling with moderately strong caustic alkalis, but is however decomposed by nitric acid. Normal lead acetate gives a cloudiness, the basic salt a precipitate, in its solutions.

¹ *Ann. d. Chem. u. Pharm.* Bd. 73, p. 322.

² *Ibid.* Bd. 99, p. 289.

³ *Ibid.* Bd. 103, p. 140.

⁴ *Ibid.* Bd. 160, p. 333.

As tests for this body may be used the formation of a port-wine colour with iodine; this disappears on warming and returns on cooling. (The same colour is produced by dextrin, but this does not reappear on cooling after its disappearance on warming.) The above readily distinguishes it from starch.

Preparation of Glycogen. The following is Brücke's¹ method. The filtered or simply strained decoction of liver or other glycogenic tissue is, when cold, treated alternately with dilute hydrochloric acid, and a solution of the double iodide of potassium and mercury², as long as any precipitate occurs. In the presence of free hydrochloric acid, the double iodide precipitates proteid matters so completely as to render their separation by filtration easy. The proteids being thus got rid of, the glycogen is precipitated from the filtrate by adding alcohol to the extent of between 60 and 70 p. c. Too much alcohol is to be avoided, since other substances as well are thereby precipitated. The glycogen is now washed with alcohol first of 60 and then of 95 per cent., afterwards with æther, and finally with absolute alcohol. It is then dried over sulphuric acid.

Dextrin. $C_6 H_{10} O_5$.

By boiling starch-paste with dilute acids, or by the action of ferments, the starch is converted into an isomeric body, to which, from its action on polarised light, the name dextrin has been given. It is soluble in water, but is precipitated by alcohol. It does not undergo alcoholic fermentation until after it has been changed into dextrose, nor can it reduce metallic salts. It yields a reddish colour with iodine, closely resembling that produced by glycogen, but unlike this, the colour formed when dextrin is present does not return on cooling after its disappearance on warming. Further action of acids or of ferments converts dextrin into dextrose. Dextrin is present in the contents of the alimentary canal after a meal containing starch, and has also been found in the blood. Concerning achroodextrin and the other varieties of dextrin see p. 185.

FATS, THEIR DERIVATIVES AND ALLIES.

THE ACETIC ACID SERIES.

General formula $C_n H_{2n} O_2$ (monobasic).

This, which is one of the most complete homologous series of organic chemistry, runs parallel to the series of monatomic alcohols. Thus formic

¹ *Sitzungsber. d. Wiener Akad.* Bd. 63. (1871) II.

² This may be prepared by precipitating potassium iodide with mercuric chloride, and dissolving the washed precipitate in a hot solution of potassium iodide as long as it continues to be taken up. On cooling, some amount of precipitate occurs, which must be filtered off; the filtrate is then ready for use.

acid corresponds to methyl alcohol, acetic acid to ethyl (ordinary) alcohol, and so on. The several acids may be regarded as being derived from their respective alcohols by simple oxidation: thus ethyl alcohol yields by oxidation acetic acid:— $C_2H_6O + O_2 = C_2H_4O_2 + H_2O$. The various members differ in composition by CH_2 , and the boiling points rise successively by about $19^\circ C$. Similar relations hold good with regard to their melting points and specific gravities. The acid properties are strongest in those where n has the least value. The lowest members of the series are volatile liquids, acting as powerful acids; these successively become less and less fluid, and the highest members are colourless solids, closely resembling the neutral fats in outward appearance. Consecutive acids of the series present but very small differences of chemical and physical properties, hence the difficulty of separating them: this is further increased in the animal body by the fact that exactly those acids which present the greatest similarities usually occur together.

The free acids are found only in small and very variable quantities in various parts of the body; their derivatives on the other hand form most important constituents of the human frame, and will be considered further on.

Formic acid. $CHO.OH$.

When pure is a strongly corrosive, fuming fluid, with powerful irritating odour, solidifying at $0^\circ C$, boiling at $100^\circ C$, and capable of being mixed in all proportions with water and alcohol. It has been found in various parts of the body, such as the spleen, thymus, pancreas, muscles, brain, and blood; from the latter it may be obtained by the action of acids on the hæmoglobin. According to some authors¹ it occurs also in urine.

Heated with sulphuric acid it yields carbonic oxide and water; with caustic potash it gives hydrogen and oxalic acid.

Acetic acid. $C_2H_3O.OH$.

Is distinguished by its characteristic odour; its boiling point is $117^\circ C$.; it solidifies at 5° and is fluid at all temperatures above $15^\circ C$. It is soluble in all proportions in alcohol and water.

It occurs in the stomach as the result of fermentative changes in the food, and is frequently present in diabetic urine. In other organs and fluids it exists only in minute traces.

With ferric chloride it yields a blood-red solution, decolorised by hydrochloric acid. (It differs in this last reaction from sulphocyanide of iron.) Heated with alcohol and sulphuric acid, the characteristic odour of acetic æther is obtained. It does not reduce silver nitrate.

¹ Buliginsky, Hoppe-Seyler's *Med. Chem. Mittheilung*. Heft 2, p. 240. Thudichum, *Journ. of the Chem. Soc.* Vol. 8, p. 400.

Propionic acid. $C_3 H_5 O . OH.$

This acid closely resembles the preceding one. It possesses a very sour taste and pungent odour; is soluble in water, boils at $141^\circ C$, and may be separated from its aqueous solution by excess of calcium chloride.

It occurs in small quantities in sweat, in the contents of the stomach, and in diabetic urine when undergoing fermentation. It is similarly produced, mixed however with other products, during alcoholic fermentation, or by the decomposition of glycerine. It partially reduces silver nitrate solutions on boiling.

Butyric acid. $C_4 H_7 O . OH.$

An oily colourless liquid, with an odour of rancid butter, soluble in water, alcohol, and æther, boiling at $162^\circ C$. Calcium chloride separates it from its aqueous solution.

Found in sweat, the contents of the large intestine, fæces, and in urine. It occurs in traces in many other fluids, and is plentifully obtained when diabetic urine is mixed with powdered chalk and kept at a temperature of $35^\circ C$. It exists, as a neutral fat, in small quantities in milk.

This is the principal product of the second stage of lactic fermentation. (See dextrose.)

Valerianic acid. $C_5 H_9 O . OH.$

An oily liquid, of penetrating odour and burning taste; soluble in 30 parts of water at $12^\circ C$, readily soluble in alcohol and æther. Boils at $175^\circ C$. Possesses, in the free and combined form, a feeble right-handed rotation of the plane of polarisation.

It is found in the solid excrements, and is formed readily by the decomposition, through putrefaction, of impure leucin, ammonia being at the same time evolved; hence its occurrence in urine when that fluid contains leucin, as in cases of acute atrophy of the liver.

Caproic acid. $C_6 H_{11} O . OH.$

Caprylic „ $C_8 H_{15} O . OH.$

Capric „ $C_{10} H_{19} O . OH.$

These three occur together (as fats) in butter, and are contained in varying proportions in the fæces from a meat diet. The first is an oily fluid, slightly soluble in water, the others are solids and scarcely soluble in water; they are soluble in all proportions in alcohol and æther. They may be prepared from butter, and separated by the varying solubilities of their barium salts.

Laurostearic acid. $C_{12} H_{23} O . OH.$

Myristic „ $C_{14} H_{27} O . OH.$

These occur as neutral fats in spermaceti, in butter and other fats. They present no points of interest.

Palmitic acid. $C_{16}H_{32}O.OH.$

Stearic „ $C_{18}H_{36}O.OH.$

These are solid, colourless when pure, tasteless, odourless, crystalline bodies, the former melting at $62^{\circ}C.$, the latter at $69.2^{\circ}C.$ In water they are quite insoluble; palmitic acid is more readily soluble in cold alcohol than stearic; both are readily dissolved by hot alcohol, æther, or chloroform. Glacial acetic acid dissolves them in large quantity, the solution being assisted by warming. They readily form soaps with the alkalis, also with many other metals. The varying solubilities of their barium salts afford the means of separating them when mixed¹: this may also be applied to many others of the higher members of this series.

These acids in combination with glycerine (see below) together with the analogous compound of oleic acid, form the principal constituents of human fat. As salts of calcium they occur in the fæces and in 'adipocere,' and probably in chyle, blood and serous fluids, as salts of sodium. They are found in the *free* state in decomposing pus, and in the caseous deposits of tuberculosis.

The existence of margaric acid, intermediate to the above two, is not now admitted, since Heintz² has shewn that it is really a mixture of palmitic and stearic acid. Margaric acid possesses the anomalous melting point of $59.9^{\circ}C.$ A mixture of 60 parts stearic and 40 of palmitic acids, melts at $60.3^{\circ}.$

ACIDS OF THE OLEIC (ACRYLIC) SERIES. $H(C_nH_{2n-3})O_2$ (monobasic).

Many acids of this series occur as glycerine compounds in various fixed fats. They are very unstable, and readily absorb oxygen when exposed to the air. The higher members are decomposed on attempting to distil them. Their most peculiar property is that of being converted by traces of NO_2 into solid, stable metameric acids, capable of being distilled. They bear an interesting relation to the acids of the acetic series, breaking up when heated with caustic potash into acetic acid and some other member of the same series:—thus,

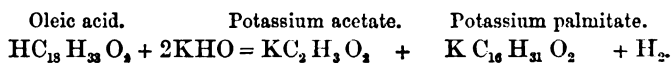

Oleic acid. $C_{18}H_{33}O.OH.$

This is the only acid of the series which is physiologically important. It is found united with glycerine in all the fats of the human body. In

¹ Heintz, *Annal. d. Phys. u. Chem.* Bd. 92, p. 588.

² *Op. cit.*

the small intestine and chyle it exists also either as a salt of potassium, or sodium, or, it may be, in the free state.

When pure it is, at ordinary temperatures, a colourless, odourless, tasteless, oily liquid, solidifying at 4° C. to a crystalline mass. Insoluble in water, it is soluble in alcohol and æther. It cannot be distilled without decomposition. It readily forms with potassium and sodium soaps, which are soluble in water: its compounds with most other bases are insoluble. It may be distinguished from the acids of the acetic series by its reaction with NO₂, and by the changes it undergoes when exposed to the air.

THE NEUTRAL FATS.

These may be considered as æthers formed by replacing the exchangeable atoms of hydrogen in the triatomic alcohol glycerine (see below), by the acid radicals of the acetic and oleic series. Since there are three such exchangeable atoms of hydrogen in glycerine, it is possible to form three classes of these æthers; only those, however, which belong to the third class occur as natural constituents of the human body: those of the first and second are only of theoretical importance.

They possess certain general characteristics. Insoluble in water and cold alcohol, they are readily soluble in hot alcohol, æther, chloroform, &c.; they also dissolve one another. They are neutral bodies, colourless and tasteless when pure; are not capable of being distilled without undergoing decomposition, and as a result of this decomposition, yield solid and liquid hydrocarbons, water, fatty acids, and a peculiar body, acrolein. (Glycerine contains the elements of one molecule of acrolein, and two molecules of water.)

They possess no action on polarised light.

They may readily be decomposed into glycerine and their respective fatty acids by the action of caustic alkalis, or of superheated steam.

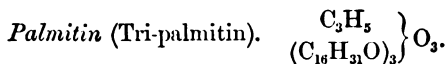

The following reaction for the formation of this fat is typical for all the others:

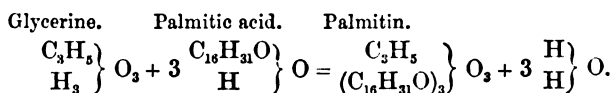

Palmitin is slightly soluble in cold alcohol, readily so in hot alcohol, or in æther; when pure it crystallises in fine needles; if mixed with stearin, it generally forms shapeless lumps, which when occurring crystallised were formerly regarded as a distinct body, namely margarin. It possesses three different melting points, according to the previous temperatures to which it has been subjected. It solidifies in all cases at 45° C.

Preparation. From palm oil, by removing the free palmitic acid with alcohol, and crystallising repeatedly from æther.

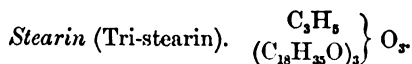

This is the hardest and least fusible of the ordinary fats of the body; is also the least soluble, and hence is the first to crystallise out from solutions of the mixed fats. It crystallises usually in square tables. It presents peculiarities in its fusing points similar to those of palmitin.

Preparation. From mutton suet, its separation from palmitin and olein being effected by repeated crystallisation from æther, stearin being the least soluble.

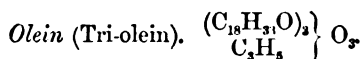

Is obtained with difficulty in the pure state, and is then fluid at ordinary temperatures. It is more soluble than the two preceding ones. It readily undergoes oxidation when exposed to the air, and is converted by mere traces of NO_2 into a solid isomeric fat. Olein yields, on dry distillation, a characteristic acid, the sebacic, and is saponified with much greater difficulty than are palmitin and stearin.

Preparation. From olive oil, either by cooling to 0° and pressing out the olein that remains fluid; or by dissolving in alcohol and cooling, when the olein remains in solution while the other fats crystallize out.

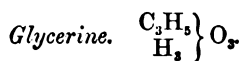

This principal constituent of the neutral fats may, as above stated, be looked upon as a triatomic alcohol.

When pure, glycerine is a viscid, colourless liquid, of a well-known sweet taste. It is soluble in water and alcohol in all proportions, insoluble in æther. Exposed to very low temperatures it becomes almost solid; it may be distilled in closed vessels without decomposition, between 275° — 280° C.

It dissolves the alkalis and alkaline earths, also many oxides, such as those of lead and copper; many of the fatty acids are also soluble in glycerine.

It possesses no rotatory power on polarized light.

It is easily recognised by its ready solubility in water and alcohol, its insolubility in æther, its sweet taste, and its reaction with bases. The production of acrolein is also characteristic of glycerine.

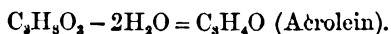

Preparation. By saponification of the various oils and fats. It is also formed in small quantities during the alcoholic fermentation of sugar¹.

ACIDS OF THE GLYCOLIC SERIES.

Running parallel to the monatomic alcohols ($C_nH_{2n+2}O$) is the series of diatomic alcohols or glycols ($C_nH_{2n+2}O_2$). Thus corresponding to ethyl alcohol is the diatomic alcohol, ethyl-glycol. As from the monatomic alcohols, so from the glycols, acids may be derived by oxidation; from the latter (glycols) however two series of acids can be obtained, known respectively as the glycolic and the oxalic series. The first stage of oxidation of the glycol gives a member of the glycolic series, thus :

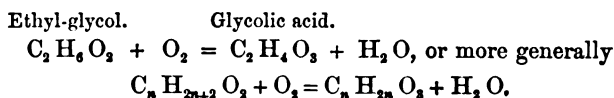

By further oxidation a member of the glycolic series can be converted into a member of the oxalic series, thus :

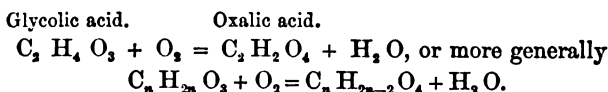

The acids of the glycolic series are diatomic but monobasic; those of the oxalic series are diatomic and dibasic.

The following table may be given to shew the general relationships of alcohols and acids :

Radical.	Alcohol.	Acid.	Glycols.	Acid I.	Acid II.
Methyl (CH_3)	$CH_3(OH)$	Formic. $HCHO_2$		Carbonic. H_2CO_3	
Ethyl (C_2H_5)	$C_2H_5(OH)$	Acetic. $HC_2H_3O_2$	Ethyl-glycol $C_2H_4(OH)_2$	Glycolic. $HC_2H_3O_3$	Oxalic. $H_2C_2O_4$
Propyl (C_3H_7)	$C_3H_7(OH)$	Propionic. $HC_3H_5O_2$	Propyl-glycol $C_3H_6(OH)_2$	Lactic. $HC_3H_5O_3$	Malonic. $H_2C_3H_3O_4$
Butyl (C_4H_9)	$C_4H_9(OH)$	Butyric. $HC_4H_7O_2$	Butyl-glycol $C_4H_8(OH)_2$	Oxybutyric. $HC_4H_7O_3$	Succinic. $H_2C_4H_4O_4$

GLYCOLIC ACID SERIES.

Lactic acid. $C_3H_5O_3$.

Next to carbonic acid, the most important member of this series, as far as physiology is concerned, is lactic acid.

Lactic acid exists in four isomeric modifications, but of these only three have been found in the human body. These three all form sirupy, colour-

¹ Pasteur, *Ann. d Chem. u. Pharm.* Bd. 106, p. 838.

less fluids, soluble in all proportions in water, alcohol and æther. They possess an intensely sour taste, and a strong acid reaction. When heated in solution they are partially distilled over in the escaping vapour. They form salts with metals, of which those with the alkalis are very soluble and crystallise with difficulty. The calcium and zinc salts are of the greatest importance, as will be seen later on.

1. *Ethylidene-lactic acid*. This is the ordinary form of the acid, obtained as the characteristic product of the well-known 'lactic fermentation'. It occurs in the contents of the stomach and intestines. According to Heintz¹ it is found also in muscles, and according to Gscheidlen² in the ganglionic cells of the grey substance of the brain. In many diseases it is found in urine, and exists to a large amount in this excretion after poisoning by phosphorous³.

It may be prepared by the general methods of slowly oxidising the corresponding glycol or by acting on the monochlorinated propionic acid with moist silver oxide. In obtaining it from the products of lactic fermentation, the crusts of zinc lactate are purified by several crystallisations, and the acid liberated from the compound by the action of sulphuretted hydrogen.

2. *Ethylene-lactic acid*. This acid is found accompanying the one next to be described, in the watery extract of muscles. From this it is separated by taking advantage of the different solubilities of the zinc salts of the two acids in alcohol. It seems probable, however, that it has not yet been prepared in the pure state by this method.

Wislicenus first obtained this acid by heating hydroxycyanide of ethylene with aqueous solutions of the alkalis⁴.

The same observer found it also in many pathological fluids.

3. *Sarcolactic acid*. This acid has not yet been procured synthetically. As its name implies, it is that form of the acid which occurs in muscles, and hence exists in large quantities in Liebig's 'extract of meat'. It is often found also in pathological fluids. This is the only acid of this series which possesses any power of rotating the plane of polarised light; it is otherwise indistinguishable from the preceding ethylidene-lactic acid, and is generally represented by the same formula. The free acid has dextro-, the anhydride levo-rotatory action. The specific rotation for the zinc salt in solution is -7.65° for yellow light.

The zinc and calcium salts of sarcolactic acid are more soluble both in water and alcohol, than those of ethylidene-lactic acid, but less so than

¹ *Ann. d. Chem. u. Pharm.* Bd. 157, p. 320.

² *Pflüger's Archiv*, viii. 171.

³ Schultzen and Riess, *Ueber acute Phosphorvergiftung*.

⁴ *Ann. d. Chem. u. Pharm.* Bd. 128, p. 6.

those of ethylene-lactic acid; and the same salts of ethylene-lactic acid contain more water of crystallisation than those of the other two.

Heintz¹ has compared the above acids to the modifications capable of existing in tartaric acid².

Hydraerylic acid, the fourth in this series of lactic acids, is distinguished by the nature of its decomposition on heating. It is never found as a constituent of animal bodies.

OXALIC ACID SERIES.

Oxalic acid. $H_2 C_2 O_4$.

In the free state this acid does not occur in the human body. Calcium oxalate, however, is a not unfrequent constituent of urine, and enters into the composition of many urinary calculi, the so-called mulberry calculus consisting almost entirely of it. It may also occur in fæces, and in the gall bladder, though this is rarely observed.

As ordinarily precipitated from solutions of calcium salts by ammonium oxalate, calcium oxalate is quite amorphous, but in urinary deposits it assumes a strongly characteristic crystalline form, *viz.* that of rectangular octohedra. In some cases it presents the anomalous forms of rounded lumps, dumb-bells, or square columns with pyramidal ends. It is insoluble in water, alcohol and æther, also in ammonia and acetic acid. Mineral acids dissolve this salt readily, as also to a smaller extent do solutions of sodium phosphate or urate. All the above characteristics serve to detect this salt; its microscopical appearance, however, is generally of most use for this purpose.

The pure acid is prepared either by oxidising sugar with nitric acid, or decomposing ligneous tissue with caustic alkalis.

Succinic acid. $H_2 C_4 H_4 O_4$.

This is the third acid of the oxalic series, being separated from oxalic acid by the intermediate malonic acid, $H_2 C_3 H_2 O_4$. It occurs in the spleen, the thymus, and thyroid bodies, hydrocephalic and hydrocele fluids.

According to Meissner and Shepard³, it is found as a normal constituent of urine. This is contested by Salkowski⁴, and also by von Speyer. It seems probable however, that since wines and fermented liquors contain succinic acid, and this latter passes unchanged into the urine, that it may thus be occasionally present in this excretion.

Succinic acid crystallises in large rhombic tables, also at times in the form of large prisms: they are soluble in 5 parts of cold water, and 2·2

¹ *Op. cit.*

² See further, Wislicenus, *Op. cit.* Also *Ann. d. Chem. u. Pharm.* Bd. 166, p. 3. Bd. 167, p. 302, and *Zeitschr. f. Chem.* xiii. S. 159.

³ *Untersuch. über d. Entsch. d. Hippursäure.* Hannover, 1866.

⁴ *Archiv d. Phys.* Bd. 2, p. 367, and Bd. 4, p. 95.

of boiling, slightly soluble in alcohol, and almost insoluble in æther. The crystals melt at 180° C, and boil at 235° C, being at the same time decomposed into the anhydride and water. The alkali salts of this acid are soluble in water, insoluble in alcohol and æther.

Preparation. Apart from the synthetic methods, it may readily be obtained by the fermentation of calcium malate, acetic acid being produced simultaneously.

Its presence is recognised by the microscopic examination of its crystals, and its characteristic reaction with normal lead acetate. With this it gives a precipitate, easily soluble in excess of the precipitant, but coming down again on warming and shaking¹.

CHOLESTERIN. (C₂₆ H₄₄ O.)

This is the only alcohol which occurs in the human body in the free state. (The triatomic alcohol glycerine is almost always found combined as in the fats; and cetyl-alcohol, or æthal, is obtained only from spermaceti.) It is a white crystalline body, crystallising in fine needles from its solution in æther, chloroform or benzol; from its hot alcoholic solutions it is deposited on cooling in rhombic tables. When dried it melts at 145°, and distils in closed vessels at 360°. It is quite insoluble in water and cold alcohol; soluble in solutions of bile salts.

Solutions of cholesterol possess a left-handed rotatory action on polarised light, of -32° for yellow light, this being independent of concentration and of the nature of the solvent.

Heated with strong sulphuric acid it yields a hydrocarbon; with concentrated nitric it gives cholesteric acid and other products. It is capable of uniting with acids and forming compound æthers.

Cholesterol occurs in small quantities in the blood and many tissues, and is present in abundance in the white matter of the cerebro-spinal axis and in nerves. It is a constant constituent of bile, forming frequently nearly the whole mass of gall stones. It is found in many pathological fluids, hydrocele, the fluid of ovarial cysts, &c.

Preparation. From gall-stones by simple extraction with boiling alcohol, and treatment with alcoholic potash to free from extraneous matter.

As tests for this substance may be given:—With concentrated sulphuric acid and a little iodine a violet colour is obtained, changing through green to red. This is applicable to the microscopic crystals. After dissolving in sulphuric acid a blood red solution is formed on the addition of chloroform, changing to purple and finally becoming colourless; the sulphuric acid

¹ For further particulars see Meissner, *Op. cit.* and Meissner and Solly, *Zeitschr. f. rat. Med.* (3) Bd. 24, p. 97.

under the chloroform has a green fluorescence. After evaporation to dryness with nitric acid, the residue turns red on treating with ammonia.

This body is described here rather for the sake of convenience than from its possessing any close relationship to the substances immediately preceding.

COMPLEX NITROGENOUS FATS.

Lecithin. $C_{44}H_{90}NPO_9$.

Occurs widely spread throughout the body. Blood, bile, and serous fluids contain it in small quantities, while it is a conspicuous component of the brain, nerves, yolk of egg, semen, pus, white blood corpuscles, and the electrical organs of the ray.

When pure, it is a colourless, slightly crystalline substance, which can be kneaded, but often crumbles during the process. It is readily soluble in cold, exceedingly so in hot alcohol; æther dissolves it freely though in less quantities, as also do chloroform, fats, benzol, carbon disulphide &c. It is often obtained from its alcoholic solution, by evaporation, in the form of oily drops. It swells up in water and in this state yields a flocculent precipitate with sodium chloride.

Lecithin is easily decomposed; not only does this decomposition set in at $70^{\circ}C$, but the solutions, if merely allowed to stand at the ordinary temperature, acquire an acid reaction, and the substance is decomposed. Acids and alkalis, of course, effect this much more rapidly. If heated with baryta water it is completely decomposed, the products being, neurin, glycerinphosphoric acid, and barium stearate. This may be thus represented:—

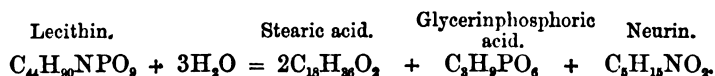

When treated in an æthereal solution with dilute sulphuric acid, it is merely split up into neurin and distearyl-glycerinphosphoric acid. Hence Diakonow¹ regards lecithin as the distearyl-glycerinphosphate of neurin, two atoms of hydrogen in the glycerinphosphoric acid being replaced by the radical of stearic acid. It appears also that there probably exist other analogous compounds in which the radicals of oleic and palmitic acids take part.

Preparation. Usually from the yolk of egg, where it occurs in union with vitellin. Its isolation is complicated, and the reader is referred to Hoppe-Seyler².

¹ Hoppe-Seyler, *Med. chem. Untersuch.* Heft 2, 1867, Heft 3, 1868. *Centralb. f. d. Med. Wiss.* Nr. 1. 7 u. 28.

² *Med. chem. Untersuch. Tübingen*, Heft 2, 1867.

Glycerinphosphoric acid. $C_3H_7PO_4$.

Occurs as a product of the decomposition of lecithin, and hence is found in those tissues and fluids in which this latter is present: in leucæmia the urine is said to contain this substance. It has not been obtained in the solid form. It has been produced synthetically by heating glycerine and glacial phosphoric acid; it may be regarded as formed by the union of one molecule of glycerine with one of phosphoric acid, with elimination of one molecule of water. It is a dibasic acid; its salts with baryta and calcium are insoluble in alcohol, soluble in cold water. Solutions of its salts are precipitated by lead acetate.

Neurin. (Cholin) $C_5H_{15}NO_2$.

Discovered by Strecker¹ in pig's-gall, then in ox-gall. It does not occur either in the free state or apart from lecithin. It is a colourless fluid, of oily consistence, possesses a strong alkaline reaction, and forms with acids very deliquescent salts. The salts with hydrochloric acid and the chlorides of platinum and gold are the most important.

Neurin is a most unstable body, mere heating of its aqueous solution sufficing to split it up into glycol, trimethylamin and ethylene oxide.

Preparation. From yolk of egg. For this see Diakonow².

Wurtz³ has obtained it synthetically, first by the action of glycol hydrochloride on trimethylamin, and then by that of ethylene oxide and water on the same substance. The above, together with the mode of its decomposition, point to the idea that neurin may be regarded as trimethyl-oxethyl-ammonium hydrate, $N(CH_3)_3(C_2H_5O)OH$.

Cerebrin. $C_{17}H_{33}NO_3$ (?).

Is found in the axis cylinder of nerves, in pus corpuscles, and largely in the brain. In former times many names were given to the substance when in an impure state, e.g. cerebriic acid, cerebrote &c. W. Müller⁴ first prepared it in the pure form, and constructed the above formula from his analysis; the mean of these is O, 15.85. H, 11.2. N, 4.5. C, 68.45. Great doubts are however thrown upon its purity, by the researches of later observers. According to Liebreich⁵ and Diakonow⁶, it is a glucoside.

Cerebrin is a light, colourless, exceedingly hygroscopic powder, which swells up strongly in water, slowly in the cold, rapidly on heating. When heated to 80° it turns brown, and at a somewhat higher temperature melts, bubbles up and finally burns away. It is insoluble in cold alcohol, or æther; warm alcohol dissolves it easily. Heated with dilute mineral acids, cerebrin

¹ *Ann. d. Chem. u. Pharm.* Bd. 123, S. 353. Bd. 148, S. 76.

² *Op. cit.*

³ *Ann. d. Chem. u. Pharm.* Sup. Bd. 6, S. 116 u. 197.

⁴ *Ann. d. Chem. u. Pharm.* Bd. 105, S. 361.

⁵ *Arch. f. pathol. Anat.* Bd. 39, 1867.

⁶ *Centralb. f. d. Med. Wiss.* 1868, Nr. 7.

yields a sugar-like body, possessing left-handed rotation, but incapable of fermentation.

Preparation. For this see W. Müller¹.

Liebreich² has described a body which he calls *protagon*, and this at one time was regarded as the essential constituent of the brain. It seems probable however that it is merely a mixture of lecithin and cerebrin³.

NITROGENOUS METABOLITES.

THE UREA GROUP, AMIDES, AND SIMILAR BODIES.

Urea. $(\text{NH}_2)_2\text{CO}$.

The chief constituent of normal urine in mammalia, and some other animals; the urine of birds also contains a small amount. Normal blood, serous fluids, lymph and the liver, all contain the same body in traces. It is not found in the muscles, though bodies capable of direct transformation into urea do exist there.

When pure it crystallises from a concentrated solution in the form of long, thin, glittering needles. If deposited slowly from dilute solutions, the form is that of four-sided prisms with pyramidal ends; these are always anhydrous. It possesses a somewhat bitter cooling taste, like saltpetre. It is readily soluble in water and alcohol, the solutions being neutral. In anhydrous æther it is insoluble. The crystals may be heated to 120° C without being decomposed; at a higher temperature they are first liquefied and then burn, leaving no residue. Heated with strong acids or alkalis, decomposition ensues, the final products being carbonic anhydride and ammonia. The same decomposition may also occur as the result of the action of a specific ferment on urea in an aqueous solution⁴. Nitrous acid at once decomposes it into carbonic anhydride and free nitrogen. It readily forms compounds with acids and bases; of these the following are of importance.

Nitrate of urea. $(\text{NH}_2)_2\text{CO} \cdot \text{HNO}_3$.

Crystallises in six-sided or rhombic tables. Insoluble in æther and nitric acid, soluble in water, slightly soluble in alcohol.

Oxalate of urea. $(\text{NH}_2)_2\text{CO} \cdot \text{H}_2\text{C}_2\text{O}_4 + \text{H}_2\text{O}$.

Often crystallises in long thin prisms, but under the microscope is obtained in a form closely resembling the nitrate; it is slightly soluble in water, less so in alcohol.

¹ *Op. cit.*

² *Ann. d. Chem. u. Pharm.* Bd. 134, S. 29.

³ Hoppe-Seyler and Diakonow, *Op. cit.*

⁴ Musculus, Pflüger's *Archiv*, xii. 214.

With mercuric nitrate urea yields three salts, containing respectively 4, 3 and 2 equivalents of mercury to one of urea. The first is the precipitate formed in Liebig's quantitative determination of urea. The exact constitution of these salts has not yet been determined.

Preparation. Ammonium sulphate and potassium cyanate are mixed together in aqueous solution, and the mixture is evaporated to dryness. The residue extracted with absolute alcohol yields urea. From urine, either by evaporating to dryness, and then extracting with alcohol, or concentrating only to a syrup, and then forming the nitrate of urea; this is washed with nitric acid and decomposed with barium carbonate.

Detection in Solutions. In addition to the microscopic appearances of the crystals obtained on evaporation, the nitrate and oxalate should be formed and examined. Another part should give a precipitate with mercuric nitrate, in the absence of sodium chloride, but not in the presence of this last salt in excess. A third portion is treated with nitric acid containing nitrous fumes; if urea is present, nitrogen and carbonic anhydride will be obtained. To a fourth part nitric acid in excess and a little mercury are added, and the mixture is warmed. In presence of urea a colourless mixture of gases (N and CO₂) is given off. A fifth portion is kept melted for some time, dissolved in water, and cupric sulphate and caustic soda are added; a red or violet colour, due to biuret, is developed.

Urea is generally considered as being an amide of carbonic acid. The amide of an acid is formed when water is removed from the ammonium salt of the acid; if the acid be dibasic and two molecules of water be removed, the result is often spoken of as a diamide. Thus if from ammonium carbonate, (NH₄)₂CO₃, two molecules of water, 2H₂O, be removed, carbonic acid being a dibasic acid, the result is urea; thus:



which may be written either according to the ammonia type as

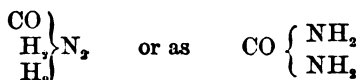

two atoms of amidogen (NH₂) being substituted for two atoms of hydroxyl (HO).

The connection between carbonic acid and urea is shewn by the fact that not only may urea be formed out of ammonium *carbamate* by dehydration, but also ammonium carbonate may be formed out of urea by hydration, as when urea is subjected to the specific ferment mentioned above. Regarded then as a diamide of carbonic acid, urea may be spoken of as carbamide. Kolbe however is inclined to regard it, not as the diamide of

carbonic acid, but as the amide of carbamic acid. Ammonium carbamate, $\text{CO}_2\text{N}_2\text{H}_4$ minus H_2O , gives urea, CO , N_2 , H_4 —which, if carbamic acid be written as CO , OH , NH_2 , may be written as CO , NH_2 , NH_2 , one atom of amidogen being substituted for one atom of hydroxyl, and not two, as when the substance is regarded as derived from carbonic acid. For the bearing of this difference of derivation see p. 352.

Wanklyn and Gamgee¹ however, since urea when heated with a large excess of potassium permanganate gives off all its nitrogen in a free state and not in the oxidized form of nitric acid, as do all other amides, conclude that it is not an amide at all, that it is isomeric only and not identical with carbamide.

It is important to remember that urea is also isomeric with ammonium cyanate, $\text{C}\left\{\begin{matrix} \text{N} \\ \text{ONH}_2 \end{matrix}\right.$, and indeed was first formed artificially by Wöhler from this body. We thus have three isomeric compounds, ammonium cyanate, urea, and carbamide, related to each other in such a way that urea may be obtained readily either from ammonium cyanate or from ammonium carbamate, and may with the greatest ease be converted into ammonium carbonate. Now urea is a much more stable body than ammonium cyanate, and in the transformation of the latter into the former, energy is set free; and it is worthy of notice that though the presence of sulphocyanides in the saliva probably indicates the existence of cyanic residues in the body, the nitrogenous products of the decomposition of proteids belong chiefly to the class of amides, cyanogen compounds being rare among them. Pflüger² has called attention to the great molecular energy of the cyanogen compounds, and has suggested that the functional metabolism of protoplasm by which energy is set free, may be compared to the conversion of the energetic unstable cyanogen compounds into the less energetic and more stable amides. In other words, ammonium cyanate is a type of living, and urea of dead nitrogen, and the conversion of the former into the latter is an image of the essential change which takes place when a living proteid dies.

Compound ureas. The hydrogen atoms of urea can be replaced by alcohol and acid radicals. The results are compound ureas. Many of them are called acids, since the hydrogen from the amide group, if not all replaced as above, can be replaced by a metal. Thus the substitution of oxalyl (oxalic acid) gives parabanic acid,

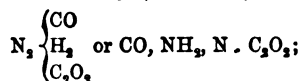

of tartronyl (tartronic acid), dialuric acid, CO , NH_2 , $\text{N} \cdot \text{C}_2\text{H}_2\text{O}_2$; of mesoxalyl (mesoxalic acid), alloxan, CO , NH_2 , $\text{N} \cdot \text{C}_2\text{O}_2$. These bodies are interesting as being also obtained by the artificial oxidation of uric acid.

¹ *Journ. Chem. Soc.* 2, Vol. vi. p. 25.

² Pflüger's *Archiv*, x. 337.

Uric acid. $C_5H_4N_4O_3$.

The chief constituent of the urine in birds and reptiles; it occurs only sparingly in this excretion in man and most mammalia. It is normally present in the spleen, and traces of it have been found in the lungs, muscles of the heart, pancreas, brain and liver. Urinary and renal calculi often consist largely of this body, or its salts. In gout, accumulations of uric acid salts may occur in various parts of the body, forming the so-called gouty concretions.

It is when pure a colourless, crystalline powder, tasteless, and without odour. The crystalline form is very variable, but usually tends towards that of rhombic tables¹. When impure it crystallises readily, but then possesses a yellowish or brownish colour. In water it is very insoluble (1 in 14,000 or 15,000 of cold water); æther and alcohol do not dissolve it appreciably. On the other hand, sulphuric acid takes it up without decomposition, and it is also readily soluble in many salts of the alkalis, as in the alkalis themselves. Ammonia however scarcely dissolves it.

Salts of Uric acid. Of these the most important are the acid urates of sodium, potassium, and ammonium. The sodium salt crystallises in many different forms, these not being characteristic, since they are almost the same for the corresponding compounds of the other two bases. It is very insoluble in cold water (1 in 1100 or 1200), more soluble in hot (1 in 125). It is the principal constituent of several forms of urinary sediment, and composes a large part of many calculi; the excrement of snakes contains it largely. The potassium resembles the sodium salt very closely, as also does the compound with ammonium; the latter occurs generally in the sediment from alkaline urine.

Preparation. Usually from guano, or snake's excrement. From guano by boiling with caustic potash (1 part alkali to 20 of water) as long as ammonia is evolved. In the filtrate a precipitate of acid urate of potassium is formed by passing a current of carbonic anhydride, and this salt is then decomposed by excess of hydrochloric acid.

The presence of uric acid is recognised by the following tests. The substance having been examined microscopically, a portion is evaporated *carefully* to dryness with one or two drops of nitric acid. The residue will, if uric acid is present, be of a red colour, which on the addition of ammonia turns to purple. This is the murexide test, and depends on the presence of alloxan and alloxantin in the residue. Schiff² has given a delicate reaction for uric acid. The substance is dissolved in sodic carbonate, and dropped on paper moistened with a silver salt. If uric acid be present

¹ See Uitzmann and K. B. Hoffmann, *Atlas der Harnsedimente*, Wien, 1872.

² *Ann. d. Chem. u. Pharm.* 109, p. 65.

a brown stain is formed, due to the reduction of the silver carbonate. An alkaline solution of uric acid can, like dextrose, reduce cupric sulphate, with precipitation of the cuprous oxide.

Unlike urea, uric acid cannot be formed artificially; and unlike urea and the urea compounds, it resists very largely the action of even strong acids and alkalis. This last fact would seem to indicate that urea residues do not pre-exist in uric acid; nevertheless by oxidation uric acid does give rise not only to ordinary urea, but also, and at the same time, to the compound ureas spoken of above. Thus by oxidation with acids,

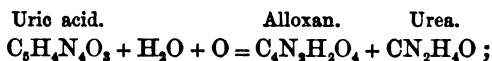

Now alloxan, as was stated above, is a compound urea, viz. mesoxalyl-urea, and by hydration can be converted into mesoxalic acid and urea, thus:

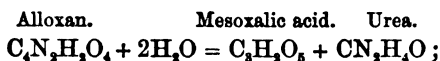

and by the action of chlorine uric acid can be split up directly into a molecule of mesoxalic acid and two molecules of urea:

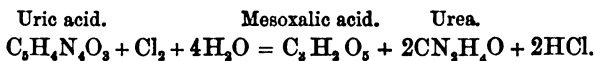

By oxidation with alkalis, uric acid is converted into allantoin and carbonic acid,

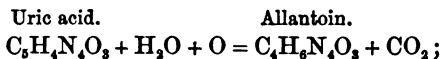

and allantoin, by hydration, becomes allanturic or lantanuric acid and urea,

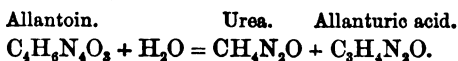

Now allanturic acid is a compound urea, with a residue of glyoxylic acid. By other oxidations of uric acid, parabanic acid (oxalyl-urea), oxaluric acid (which is hydrated parabanic acid), and dialuric acid (tartronyl-urea) are obtained. In fact all these decompositions of a molecule of uric acid lead to two molecules of urea and a carbon acid of some kind or other.

There are however reasons for thinking that before the urea can be obtained from the uric acid a molecular change takes place; that part of the nitrogen of uric acid exists as a cyanogen residue, which on the splitting up of the uric acid is converted into the same condition as the rest of the nitrogen, viz. into the amide condition. It has been supposed indeed that uric acid is tartronyl cyanamide, in which two molecules of amidogen have been replaced by the radical of tartronic acid, and two others by two atoms of cyanogen, thus:

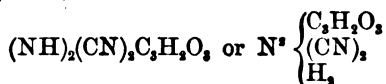

If this be so, since the metabolism of the animals in which uric acid replaces urea cannot be supposed to be fundamentally different from that of the urea-producing animals, we may infer that the antecedent of both uric acid and urea in the regressive metabolism of proteids is, as we suggested above, a body containing some at least of its nitrogen in the form of cyanogen.

Kreatin. $C_4H_7N_3O_2$.

Occurs as a constant constituent of the juices of muscles, though possibly it may be formed during the process of extraction by the hydration of kreatinin. Kreatin is not a normal constituent of urine, but it is said to occur in traces in several fluids of the body. When found in urine its presence is probably due to the conversion of kreatinin, a constant constituent of urine, into kreatin during its extraction, since Dessaignes' has shewn that the more rapidly the separation is effected, the less is the quantity of kreatin obtained, and the greater the amount of kreatinin.

In the anhydrous form it is white and opaque, but crystallises with one molecule of water in colourless transparent rhombic prisms. It possesses a somewhat bitter taste, is soluble in cold, extremely soluble in hot water, is less soluble in absolute than in dilute alcohol, and is insoluble in æther.

It is a very weak base, scarcely neutralising the weakest acids. It forms crystalline compounds with sulphuric, hydrochloric and nitric acids.

Preparation. From extract of muscle by precipitating completely with basic lead acetate, and crystallising out the kreatin, mixed with kreatinin. From this latter it is separated by the formation of the zinc-salt of kreatinin, kreatin not readily yielding a similar compound.

Kreatin may be converted into kreatinin under the influence of acids, the transformation being one of simple dehydration.

Kreatin may be decomposed into sarcosin (methyl-glycin) and urea

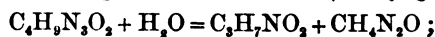

it may be formed synthetically² by the action of sarcosin and cyanamide:



Sarcosin is glycin in which one atom of hydrogen has been replaced by the alcohol radical methyl, thus:

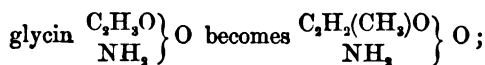

like glycin, sarcosin has not been found in a free state in the body.

¹ *J. Pharm.* (3) xxxii. p. 41.

² *Sitzungsber. d. bayersch. Akad.* 1868, Hft. 3, p. 472.

Kreatinin. $C_4H_7N_3O$.

This, which is simply a dehydrated form of kreatin, occurs normally as a constant constituent of urine and of muscle extract. It crystallises in colourless shining prisms, possessing a strong alkaline taste and reaction. It is readily soluble in cold water (1 in 11.5), also in alcohol, but is scarcely soluble in æther. It acts as a powerful alkali, forming with acids and salts compounds which crystallise well. Of these the most important is the salt with zinc chloride ($C_4H_7N_3O$), $ZnCl_2$. It is formed when a concentrated solution of the chloride is added to a not too dilute solution of kreatinin. Since the compound is very little soluble in alcohol, it is better to use alcoholic rather than aqueous solutions. It crystallises in warty lumps composed of aggregated masses of prisms, or fine needles.

Preparation. Either by the action of acids on kreatin, or from human urine by concentrating, and precipitating with lead acetate; in the filtrate from this, a second precipitate is caused by the addition of mercuric chloride, and consists of a compound of this salt with kreatinin. The mercury is removed by sulphuretted hydrogen, and the kreatinin purified by the formation of the zinc salt, and washing with alcohol.

Kreatinin-zinc chloride may be converted into kreatin, by the action of hydrated oxide of lead on its boiling aqueous solution.

Allantoin. $C_4H_6N_4O_3$.

The characteristic constituent of the allantoinic fluid of the fœtus; it occurs also in the urine of animals for a short period after their birth. Traces of it are sometimes detected in this excretion at a later date.

It crystallises in small, shining, colourless prisms, which are tasteless and odourless. They are soluble in 160 parts of cold, more soluble in hot water, insoluble in cold alcohol and æther, soluble in hot alcohol. Carbonates of the alkalis dissolve them, and compounds may be formed of allantoin with metals but not with acids.

Allantoin, as already stated, p. 615, is one of the products of the oxidation of uric acid, and by further oxidation gives rise to urea.

Preparation. This is best done by the careful oxidation of uric acid either by means of potassium permanganate or ferrocyanide, or by lead oxide.

Hypoxanthin or Surkin. $C_5H_4N_4O$.

Is a normal constituent of muscles, occurring also in the spleen, liver, and medulla of bones. In leuchæmia it appears in the blood and urine. It crystallises in fine needles which are soluble in 300 parts of cold, more soluble in hot water, insoluble in alcohol, soluble in acids and alkalis. It forms crystalline compounds with acids and bases. It is precipitated by basic acetate of lead, the precipitate being soluble in a solution of the

normal acetate. Its preparation from muscle-extract depends on its precipitation first by basic acetate of lead, and then by an ammoniacal solution of silver nitrate after the removal of kreatin.

Xanthin. $C_5H_4N_4O_2$.

First discovered in a urinary calculus, and called xanthic oxide. More recently it has been found as a normal, though scanty, constituent of urine, muscles, and several organs, such as the liver, spleen, thymus, &c.

When precipitated by cooling from its hot, saturated, aqueous solution it falls in white flocks, but if the solution be allowed to evaporate slowly it is obtained in small scales. When pure it is a colourless powder, very insoluble in water, requiring 1500 times its bulk for solution at $100^\circ C$. Insoluble in alcohol and æther, it readily dissolves in dilute acids and alkalis, forming crystallisable compounds.

Hypoxanthin by oxidation becomes xanthin. Both these bodies, as well as the following, guanin and carnin, are evidently closely allied to uric acid; indeed, uric acid by the action of sodium-amalgam may be converted into a mixture of xanthin and hypoxanthin.

Preparation. It is obtained from urine and the aqueous extract of muscle by a process similar to that for hypoxanthin, and is then separated from the latter by the action of dilute hydrochloric acid; this separation depends on the different solubilities of the hydrochlorates of the two bodies. For further information see Neubauer¹.

Carnin. $C_7H_8N_4O_2$.

Discovered by Weidel² in extract of meat, of which it constitutes about one per cent.

It crystallises in white masses composed of very small irregular crystals; it is soluble with difficulty in cold, more easily soluble in hot water, insoluble in alcohol and æther. Its aqueous solution is not precipitated by normal lead acetate, but is by the basic acetate of this metal. It unites with acids and salts forming crystalline compounds.

Preparation. Is found in the precipitate caused in extract of meat by basic acetate of lead³.

This body possesses an interesting relation to hypoxanthin, into which it may be converted by the action either of nitric acid or, still better, of bromine.

Guanin. $C_5H_6N_6O$.

First obtained from guano, but recently observed as occurring in small quantities in the pancreas, liver and muscle extract.

¹ *Harn-Analyse*, 7 Ed. p. 24.

² *Ann. d. Chem. u. Pharm.* Bd. 158, p. 365.

³ See Weidel, *Op. cit.*

It is a white amorphous powder, insoluble in water, alcohol, æther and ammonia. It unites with acids, alkalis and salts to form crystallisable compounds.

Preparation. From guano by boiling successively with milk of lime and caustic soda, precipitating with acetic acid, and purifying by solution in hydrochloric acid and precipitation by ammonia.

Guanin may, by the action of nitrous acid, be converted into xanthin. By oxidation it can be made to yield principally guanidine and parabanic acid, accompanied however by small quantities of urea, xanthin and oxalic acid.

Its separation from hypoxanthin and xanthin depends on its insolubility in water and behaviour with hydrochloric acid.

Kynurenic acid. $C_{20}H_{14}N_2O_6 + 2H_2O$.

Found in the urine of dogs, and first described by Liebig¹. When pure it crystallises in brilliant white needles, insoluble in cold, soluble in hot alcohol. The only salt of this body which crystallises well is that formed with barium. For preparation and other particulars see Liebig² and Schultzen and Schmiedeberg³.

Glycin. $C_2H_5(NH_2)O(OH)$. Also called Glycocoll and Glycocine.

Does not occur in a free state in the human body, but enters into the composition of many important substances, *e. g.* hippuric and bile acids. It crystallises in large, colourless, hard rhombohedra, which are easily soluble in water, insoluble in cold, slightly soluble in hot alcohol, insoluble in æther. It possesses an acid reaction, but a sweet taste. It has also the property of uniting with both acids and bases, to form crystallisable compounds. In this it exhibits its amide nature, and that it is an amide is rendered evident from the methods of its synthetic preparation; thus mono-chlor-acetic acid and ammonia give glycin and ammonium chloride:— $C_2H_5ClO_2 + 2NH_3 = C_2H_5(NH_2)O(OH) + NH_4Cl$. It is amido-acetic acid. Heated with caustic baryta it yields ammonia and methylamine.

Preparation. From glutin by the action of acids or alkalis; from hippuric acid by decomposing this with hydrochloric acid at a boiling temperature and removing by precipitation the simultaneously formed benzoic acid.

Taurin. $C_2H_7NO_3S$.

In addition to entering into the composition of taurocholic (see p. 625) acid, taurin is found in traces in the juices of muscle and of the lungs.

¹ *Ann. d. Chem. u. Pharm.* Bd. 86, p. 125. and Bd. 108, p. 374.

² *Op. cit.*

³ *Ann. d. Chem. u. Pharm.* Bd. 114, p. 155.

It crystallises in colourless, regular, six-sided prisms; these are readily soluble in water, less so in alcohol. The solutions are neutral. It is a very stable compound, resisting temperatures of less than 240°C; it is not acted on by dilute alkalis and acids, even when boiled with them. It is not precipitated by metallic salts.

Taurin is amido-isethionic acid; and may be synthetically prepared from isethionic (ethyl-sulphuric) acid by the action of ammonia; thus:

Isethionic acid. Ammonia. Taurin.

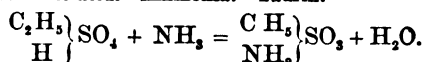

Preparation. As a product of the decomposition of bile, and is purified by removing any traces of bile acids by means of lead acetate, and then successively crystallising from water.

Leucin. $\text{C}_6\text{H}_{13}\text{NO}_2$.

Is one of the principal products of the decomposition of nitrogenous matter, either under the influence of putrefaction or of strong acids and alkalis. It occurs however normally in the pancreas, spleen, thymus, thyroid, salivary glands, liver, &c., and is one of the products of the tryptic (pancreatic) digestion of proteids; in acute atrophy of the liver it is present in the urine in large quantity, in company with tyrosin.

As usually obtained in an impure form it crystallises in rounded lumps which are often collected together, and sometimes exhibit radiating striation. When pure, it forms very thin, white, glittering flat crystals. These are easily soluble in hot water, less so in cold water and alcohol, insoluble in æther. They feel oily to the touch, and are without smell and taste. Acids and alkalis dissolve them readily, and crystallisable compounds are formed.

Carefully heated to 170° it sublimes, but at a higher temperature is decomposed yielding amylamin, carbonic anhydride and ammonia. In the presence of putrefying animal matter it splits up into valeric acid and ammonia; in this it exhibits its amide nature.

Leucin is amido-caproic acid, and may be written thus:

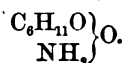

Preparation. From horn-shavings by boiling with sulphuric acid, neutralising with baryta and separating from tyrosin by successive crystallisation. See also Kühne¹.

Scherer has given the following test for leucin. The suspected substance is evaporated carefully to dryness with nitric acid; the residue, if it

¹ Virchow's *Archiv*, Bd. 39, S. 130.

is leucin, will be almost transparent and turn yellow or brown on the addition of caustic soda. If heated again with the alkali an oily drop is obtained, which is quite characteristic of this substance. Leucin, if not too impure, may be easily recognised by its subliming on being heated; a characteristic odour of amylin is at the same time evolved.

Cystin. $C_3H_7NSO_2$.

Is the chief constituent of a rarely occurring urinary calculus in men and dogs. It may also occur in renal concretions, and in gravel.

From calculi it is obtained, by extraction with ammonia, as colourless six-sided tables or rhombohedra, which are neutral and tasteless. It is insoluble in water, alcohol and æther, soluble in ammonia and the other alkalis, and also in mineral acids. The fact that this body is one of the few crystalline substances, occurring physiologically, which contain sulphur, renders its detection very easy. Apart from its insolubility in water, &c., it yields with caustic potash and salts of either silver or lead, a brown colouration due to the presence of the sulphides of these metals.

According to Dewar and Gamgee¹ cystin is amido-sulpho-pyruvic acid, and its formula is $C_3H_5NSO_2$ —pyruvic being lactic acid minus two atoms of hydrogen.

THE AROMATIC SERIES.

Benzoic acid. $HC_7H_5O_2$.

This is not found as a normal constituent of the body, but owes its presence in urine to the decomposition of hippuric acid, whereby glycin and benzoic acid are formed:

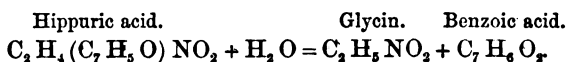

The sublimed acid is generally crystallised in fine needles, which are light and glistening; any odour they possess is not due to the acid, but to an essential oil, with which they are mixed. When precipitated from solution, the crystalline form is always indistinct. This acid is soluble in 200 parts cold, or 25 parts of boiling water, but is easily soluble in alcohol or æther. It sublimes readily at $145^\circ C$; it also passes off in the vapours arising from its heated solutions.

Preparation. Either as above from hippuric acid by fermentation, or the action of hydrochloric acid, or by sublimation from gum-benzoin.

Tyrosin. $C_9H_{11}NO_2$.

Generally accompanies leucin, and is perhaps found normally in small quantities in the pancreas and spleen. It is also usually obtained in large

¹ *Journ. of Anat. and Physiol.* Nov. 1870, p. 143.

quantities by the decomposition of proteid matter, either by putrefaction or the action of acids.

The researches of Radziejewsky¹ render it probable that tyrosin does not occur normally in any part of the human organism, except as a product of pancreatic digestion.

It crystallises in exceedingly fine needles which are usually collected into feathery masses. The crystals are snow-white, tasteless and odourless, almost insoluble in cold water, readily soluble in hot water, acids and alkalis, insoluble in alcohol and æther. If crystallised from an alkaline solution tyrosin often assumes the form of rosettes composed of fine needles arranged radiately.

Tyrosin does not sublime by heating, but is decomposed with an odour of phenol and nitrobenzol. On boiling with Millon's reagent it gives a reaction almost identical with that for proteids (Hoffmann's test). Treated with strong sulphuric acid and gently warmed, it yields, on the addition of chloride of iron, a violet colour (Piria's test).

Tyrosin is an ammonia compound belonging to the aromatic (benzoic) series.

Preparation. By means similar to those employed for leucin, the separation of the two depending on their solubilities. According to Kühne's method² large quantities are easily obtained as the result of pancreatic digestion. It has not yet been formed synthetically.

Hippuric acid. $C_9H_9NO_3$. Or Benzoyl-glycin. $C_2H_4(C_7H_5O)NO_2$.

Is found in considerable quantities in the urine of herbivora, and also, though to a much smaller amount, in the urine of man. It is formed in the body by the union with dehydration of glycin and benzoic acid, see p. 354.

Crystallised from a saturated aqueous solution, it assumes the form of fine needles; if from a more dilute solution, white, semitransparent four-sided prisms are obtained. These when pure are odourless, with a somewhat bitter taste. They are soluble in 600 parts of cold water, readily soluble in alcohol, less so in æther. All the solutions redden litmus.

Hippuric acid is monobasic, and forms salts which are readily soluble in water (except the iron salts); from these, if in sufficiently concentrated solutions, excess of hydrochloric acid precipitates the acid in fine needles. When heated with concentrated mineral acids it is resolved into benzoic acid and glycin. The same decomposition occurs in presence of putrefying bodies. Strong nitric acid produces an odour of nitrobenzol.

¹ *Archiv f. path. Anat.* Bd. 36, p. 1. *Zeitsch. f. anal. Chem.* Bd. 5, p. 466.

² *Virchow's Arch.* Bd. 39, p. 130.

Preparation. Fresh urine of horses or cows is boiled with milk of lime, filtered, and the filtrate evaporated to a small bulk; the hippuric acid is then precipitated by adding an excess of hydrochloric acid.

When heated in a small tube, hippuric acid gives a sublimate of benzoic acid and ammonium benzoate, accompanied by an odour like that of new hay, while oily, red drops are observed in the tube. This is very characteristic, and distinguishes it from benzoic acid.

Phenylic (Carbolic) acid. C_6H_6O .

This acid occurs only as a urinary constituent. According to the older view it was a normal constituent of this excretion; it seems, however, more probable that it is due to some decomposition occurring in the urine, by the processes requisite for its isolation.

Buliginsky¹ says the urine of many animals, of cows and horses always, contains a substance insoluble in alcohol, and not precipitated by lead acetate and ammonia, which by the action of dilute mineral acids gives carbolic acid. The same acid applied to the body externally or internally also passes into the urine². Similarly benzol (C_6H_6) when taken into the stomach appears as carbolic acid in the urine³.

The pure acid crystallises in long, colourless prismatic needles; they melt at $35^\circ C$, and boil at $180^\circ C$. It is readily soluble in alcohol and æther, slightly soluble in water (1 part in 20). In most cases it acts as a weak acid, forming crystalline salts with the alkalis. With nitric acid it yields picric acid. Its solutions reduce silver and mercury salts.

Preparation. By the dry distillation of salicylic acid, also from the acid products of the distillation of coal.

THE BILE SERIES.

Cholic (or cholalic) acid. $H.C_{24}H_{39}O_5 + H_2O$.

Occurs in traces in the small intestine, in larger quantities in the contents of the large intestine, and the excrements of men, cows and dogs. In Icterus, the urine often contains traces of this acid. But its principal interest lies in its being the starting point for the various bile acids (see below). The pure acid may be amorphous, or crystalline, in the latter case crystallising from hot alcoholic solutions in tetrahedra. These crystals are insoluble in water and æther. In the amorphous form, it is somewhat soluble in water and æther. Heated to $200^\circ C$, it is converted into water and dyslysin ($C_{24}H_{39}O_3$).

¹ Hoppe-Seyler, *Med. Chem. Untersuch.* 1867, Heft 2, p. 234.

² Almén, *Neues Jahrb. d. Pharm.* Bd. 34, p. 111. Salkowski, *Pfüger's Archiv*, Bd. 5, p. 335.

³ Schultzen and Naunyn, Reichert u. Du-Bois Reymond's *Archiv*, 1867, Heft 3.

This acid possesses, in the anhydrous condition, a specific rotatory power of $+50^\circ$ for yellow light: when it crystallises with H_2O , the rotation is $+35^\circ$. The rotatory power of the alkali salts are always less than the above, and when in solution in alcohol, the rotation is independent of the concentration. For the alcoholic solution of the sodium salt, the rotation is $+31.4^\circ$.

Preparation. By the decompositions of bile acids by means of acids, alkalis, or fermentative changes.

Pettenkofer's test.

This well-known test for bile acids depends on the reaction of cholalic acid in presence of sugar and sulphuric acid. If to a solution of the acid a little sugar be added, and then sulphuric acid, keeping the temperature below but not much below $70^\circ C$, a beautiful reddish purple is obtained. This gives a characteristic spectrum with two absorption bands, one between *D* and *E*, nearest to *E*, the other close to *F* on the red side of *F*.

Proteids, and other bodies easily decomposed by sulphuric acid such as amylo-alcohol, give a similar colouration, and the reaction is much impeded by the presence of colouring matters¹.

Glycocholic acid. $C_{26}H_{43}NO_6$.

This is the principal bile-acid of ox-gall; it is also present in the bile of man, but has so far not been observed in that of carnivora. In Icterus, the urine may contain traces of this acid.

It crystallises in fine, glistening needles. These are slightly soluble in cold water; readily so in hot water and alcohol; insoluble in æther. They possess a bitter and yet sweet taste, and a strong acid reaction.

The salts of this acid are readily soluble in water and crystallise well. The salts, as well as the free acid, exert right-handed polarisation amounting to $+29.0^\circ$ for the acid, and $+25.7^\circ$ for the sodium salt, both measured for yellow light.

Glycocholic acid is a compound of glycin and cholalic acid; thus:

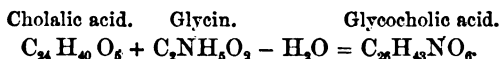

Prolonged boiling with dilute mineral acids or caustic alkalis decomposes this body into glycin and cholalic acid; if dissolved in concentrated sulphuric acid and then warmed, one molecule of water is removed, and cholonic acid obtained, $C_{26}H_{41}NO_5$. The barium salt of this last acid is insoluble in water, which fact is of importance, since cholonic acid possesses nearly the same specific rotatory power as glycocholic.

¹ For further information on this subject see: Bischoff, *Zeitschr. f. rat. Med.* Ser. 8, Bd. 21, p. 126. Schenk, *Anatom. physiol. Untersuch.* Wien, 1872, p. 47.

Preparation. From ox-gall, by evaporating to a syrup, decolorising with animal charcoal, extracting with strong alcohol, and precipitating by a large excess of æther. Its separation from taurocholic acid depends on the precipitation of its solution by normal lead acetate.

Taurocholic acid. $C_{26}H_{45}NSO_7$.

Occurs also in ox-gall, but is found especially plentiful in human bile and that of carnivora.

It has not yet been obtained in the crystalline form¹, although its salts crystallise readily. When dried it is an amorphous powder, with pure bitter taste, easily soluble in water and alcohol, insoluble in æther. All its salts are soluble in water, and are precipitated by basic lead acetate only in the presence of free ammonia. The sodium salt dissolved in alcohol has a specific rotatory power of $+24.5^\circ$; if dissolved in water this rotation is less, and in this respect it resembles glycocholic acid.

This acid is far more unstable than the preceding one, being decomposed if boiled with water. The products of decomposition are taurin and cholalic acid.

Taurocholic acid is a compound of taurin and cholalic acid; thus:

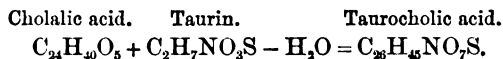

Preparation. From the gall of dogs by a process similar to that for glycocholic acid. It is separated from traces of this latter and from cholic acid by preparation with basic lead acetate and ammonia.

THE INDIGO SERIES.

Indican.

There often occurs in the urine and sweat of men and animals a certain substance which has not yet been satisfactorily isolated, but which yields by the action of acids the blue colouring matter indigo as one product of the decomposition. A similar substance is found in several plants (*Indigofera*, *Isatis*), and the two have been considered identical; in the present state of information on this subject it cannot with certainty be stated whether this is so or not. For its preparation and quantitative determination see Jaffé, *Arch. f. d. ges. Physiol.* III. p. 448; also Schunk, *Phil. Mag.* Vol. x. p. 73, XIV. p. 228, XV. p. 29, 117, 183. *Chem. Centralb.* 1856, p. 50, 1857, p. 957, 1858, p. 225.

It is always estimated by conversion into indigo.

¹ Neubauer u. Vogel, *Harn-Analyse.* Ed. VII. p. 97.

Indigo. C_8H_5NO .

It is formed, as stated above, from indican, and gives rise to the bluish colour sometimes observed in sweat and urine.

It may, by slow formation from indican, be obtained in fine crystals; these are insoluble in water, slightly soluble with a faint violet colour in alcohol and æther. Chloroform also dissolves them to a slight extent. Indigo is soluble in strong sulphuric acid, forming at the same time two compounds with this acid; these are soluble in water. It possesses a pure blue colour; when pressed with a hard body a reddish copper-coloured mark is left, and the crystals exhibit the same colour if seen in reflected light.

The soluble compounds with sulphuric acid give an absorption band in the spectrum which lies close to the *D* line and to the red side of it. This may be used to detect indigo.

Treated with reducing agents, indigo is decolorised, being reduced to indigo-white. The latter contains two atoms more hydrogen than indigo.

Indol. C_8H_7N .

To this body the specific odour of the feces is partly due. It is obtained as the final product of the reduction of indigo; and also by the distillation of proteid matter with caustic alkalis.

It often occurs among the products of the action of pancreatic ferment on proteids; its presence in such cases appears however to be due, not to the action of the trypsin, but to a simultaneous putrefaction under the influence of bacteria, etc.¹ If the pancreatic digestion be carried on in the presence of salicylic acid, indol does not make its appearance; see p. 201. Indol gives a characteristic red colour with nitrous acid.

¹ Kühne, *Verhand. d. Heidelb. Naturhist. Med. Ver.* N.S. Bd. 1. Hft. 3. *Bericht. d. Deutschen Chem. Gesellschaft*, 1875, p. 206.

I N D E X.

- ABERRATION**, spherical, of the eye, 410
Absorption by the skin, 316
Absorption of fat, proteids, and products of digestion, 244, 250
Absorption of food by diffusion, 250
Accelerating fibres, 94
Accelerator nerves, 148, 153, 177
Accommodation, power of, in the eye, 301
Acetic acid, 600
Achroodextrin, 185, 339
Acid-albumin, 575, 591
Acidity of urine, 319
Acids, decomposition of proteids by, 588
Acids in perspiration, 313
Acoustic apparatus of the ear, 449
ADAMUK on the brain, 514
Adipose tissue (See Fat)
Afferent impulses, 90, 147, 471; of vasomotor action, 160, 163, 164, 165; of deglutition, 230; in respiration, 289; in micturition, 328; nerves conveying, 389
After-images of vision, 426
Air, tidal, stationary and residual, in respiration, 254; its changes in respiration, 264, 302
ALADOFF on diabetes, 338
ALBERTONI, the brain, 505
Albumin, action of gastric juice on, 190
Albumins, 573, 590
Albuminates, 575
Alimentary canal, 183; changes of food in the, 237
Alimentary mechanism, 7
Alkali-albumin, 577, 591
Alkaline urine of herbivora, 320
Allantoic vessels, 547
Allantoin, 617
Ammonia in expired air, 266
Amœbæ, properties of, 1, 86, 224, 247, 345
Amyolytic action of pancreatic juice, 199; of saliva, 185, 186, 221
Amyolytic ferment, 222
Analyses, of perspiration, 312; of the composition of the animal body, 355, 556
Anelectrotonus, 61, 62, 66
Animal body, chemical basis of the, 571
Antipeptone, 202
Antiperistaltic action, 230
Anus, 233
Aorta, pressure in, 122
Aortic valves, 123
Apnoea, 229, 294, 306
Appreciation of apparent size, 434
Arterial blood, 267, 276, 280, 282, 283, 286, 293, 297
Arterial pulse (See Pulse)
Arteries, 84, 98, 103, 107, 109, 110; contractility and dilation of, 154, 207, 215; renal, 321
Artificial diabetes, 337
Ascending aorta, pulse wave in, 135
Asphyxia, 229, 259, 289, 293, 302, 308
Aspirates (voice) 534
Astigmatism, 410
Atropin, its effects, 145, 230, 324, 408
ARBERT on cutaneous respiration, 313
Auditory sensations, 452
AUERBACH, nervous plexus in the intestines, 90; peristaltic movements in digestion, 228
Augmenting fibres, 94
Auricles, blood-pressure in, 119
Auriculo-ventricular valves, 122
Automatic action, 2, 86, 88, 90, 147; of the heart, 159; of peristaltic movements, 228; of the respiratory centre, 289; the spinal cord as a centre of this action, 478
Automatic tissues, 5
Axillary artery of the tortoise, its contractility, 155

Bacteria, 242, 244
BALOGH, cerebral convolutions, 504
Banting's dietetic system, 364
Bat, movement of veins in its wing, 155
BAUER, absorption of products of digestion, 244
BAXT, cardiac accelerator nerves, 149; velocity of nervous impulses, 394
Beat of the heart (See Heart-beat)
BEAUMONT, Dr, researches on digestion, 252
BECHER, on respiration, 265, 282, 283
BECKER, mechanism of salivary secretion, 213
Bed-sores, 381
Bees, temperature of, 372
Behaviour of brainless animals, 471, 489
BELL, SIR CHAS., roots of spinal nerves, 390; motor and sensory fibres, 525
Benzoic acid, 621
BERNARD, CLAUDE, on the 'internal medium', 11; section of the cervical sympathetic, 169, 179; pancreatic juice, 199; secretion of saliva, 207; mechanism of digestive secretion, 208, 213; digestion, 240, 243, 252; hæmoglobin, 278; cutaneous secretion, 315; glycogen, 331; thermogenic and frigorific nerves, 379; olfactory organs, 459
BERNOULLI's model of respiratory movements, 261

- BERNSTEIN**, on nerve-currents, 50; muscular contraction, 54, 69
- BERNSTEIN**, N. O., pancreatic juice, 198, 204, 216
- Beroe**, muscular fibre in, 32
- BERZELIUS**, researches on digestion, 252
- BICHAT**, on death, 567
- BIDDER** and **SCHMIDT**, on digestion, 241, 252; on nutrition and starvation, 357, 386
- BIDDER**, nerves of the submaxillary ganglion, 209
- Bile**, 183, 195—198, its colour, 195, constituents, pigments, 195, 224; bile-salts, 196, 624; action on food, 197; secretion of, 215, 223; its effect on fat, 241; in the fœtus, 549
- Bilirubin**, 30, 195
- Billiverdin**, 196
- Binocular vision**, 446
- Birds**, brainless, their behaviour, 491, 517
- Birds**, uric acid in, 353
- BISCHOFF**, on nutrition and starvation, 357, 386
- BLACK'S** discovery of carbonic acid in air, 310
- Bladder**, 327
- BLAGDEN**, Dr, effects of heat, 375
- Blastoderm**, 547
- Blind spot**, 429, 434
- Blood**, 6, 11—31; its chemical composition, 12; coagulation, 14; fibrin, 15; fibrinoplastin and fibrinogen, 18; fibrin-ferment, 20; influence of the living blood-vessels, 22; sources of the fibrin-factors, 24; history of the corpuscles, 27; quantity and distribution of blood in animals and man, 31; velocity of flow; Volkmann's hemadrometer, 103; Ludwig's stromuhr (diagram) 104; Vierordt's hæmatometer, 105; sugar in, 250
- Blood**, changes in quantity and quality, 174—179; effect of its condition on peristaltic movements, 229; respiratory changes in it, 267; relations of oxygen in the blood, 268; colour of arterial and venous, 276; effect of respiration, 280, 283, 293; relations of carbonic acid and nitrogen in blood, 280, 281
- Blood**, circulation of the, 96—179
- Blood**, in menstruation, 542
- Blood**, of the fœtus, 548, 550
- Blood-pressure**, 99—179; apparatus for investigating (diagram), 100; endocardiac pressure; Fick's manometer, curves of pressure in cavities of heart, left ventricle and aorta (diagrams), 120, 121, 122; its relation to heart-beat, 150, 153; effect of bleeding and injection of blood, 175, 210, 204; in asphyxia, 304; in secretion of urine, 321
- Blood-supply**, its influence on muscular contraction, 74, 77
- BOCHEFONTAINE**, cerebral convolutions, 504
- BOLL**, visual purple of the retina, 414
- Bone**, 4, 7
- Bones**, broken, 541
- BOWMAN**, on renal secretion, 324
- BOYLE**, on respiration, 541
- Brachial plexus**, section of, 156, 157
- Brain**, the, and automatic reflex action in, 94; pulsation of the, 295; kreatin in, 349; a source of heat, 373; its functions, 489—526; cerebral convolutions in the dog and man (diagrams), 501, 502, 503; effects of stimulation of, 554; growth of the, 561
- Brainless animals**, behaviour of, 471, 478, 489
- Bread** (*See* Dietetics, Nutrition)
- Breathing** (*See* Respiration)
- BREYER**, respiratory action of vagus, 290
- 'Bright' colours**, 427
- BRODIE**, bodily heat, 377
- BROWN-SEQUARD**, vascular mechanism, 179; on the spinal cord, 483; cerebral convolutions, 504
- BRÜCKE**, on blood-clotting, 22, 24; semi-lunar valves of the heart, 123; digestion of starch, 185; peptone and pepsin, 193, 202, 221
- 'Buffy coat' in blood**, 15
- BUNGE**, hippuric acid, 354
- BUSCH**, movements of the stomach, 233; digestion, 241
- Butyric acid**, 601
- Cæcum**, 243
- Calcareous degeneration**, 562
- CAMPBELL**, pigments of bile, 196
- Capillary circulation**, 97, 106, 107, 109, 179; changes in peripheral resistance, 171—174; blood-pressure in renal secretion, 321
- Caproic acid**, 601
- Carbohydrate food**, effects of, 363
- Carbohydrates in the human body**, 595
- Carbonic acid**, 622
- Carbonic acid**, in expired air, 254, 265, 266, 267; in the blood, 268; exit from blood, 282; in the tissues, 285; effects of excess of, 295, 307
- Cardiac impulse**, 115, 127
- Cardiac muscles**, 83
- Cardiac sound**, for measuring blood-pressure (diagram), 117
- Cardiograph**, 115, 139
- Cardio-inhibitory centre**, 147, 151, 177
- Carnin**, 618
- Carnivorous animals**, nutrition of, 365
- Carotid artery**, blood-pressure in, 99, 102
- Cartilage**, 5, 7
- Cartilages of the ribs**, their action in respiration, 261
- Cartilages**, nasal, 264
- CARVILLE**, on the brain, 514
- Casein**, 345, 578
- Cat**, saliva of, 187; blood-crystals, 271; perspiration, 315, 316; composition of body, 356
- Cells**, migrating, 84; ectodermic and en-

- dodermic, 85; epithelium, of alimentary canal, 183
- Cellulose, 184
- Central nervous mechanism, 8, 87
- Centres of organic functions in medulla oblongata, 520
- CERADINI, on valves of the heart, 124
- Cerebellum, 517
- Cerebral actions, rapidity of, 521
- Cerebral convolutions of the dog and man (diagrams), 501, 502, 503
- Cerebrin, 610
- Cervical sympathetic, section of the, 167
- CHAPERON, spinal cord, 475
- CHAUVEAU, instrument for measuring blood pressure, 106, 116; movements of the œsophagus, 231
- Chemical Action, tissues of, 183—310; Digestion, 183—252; Respiration, 253—310
- Chemical aspects of respiration, 287
- Chemical basis of the animal body, 571
- Chemical changes in muscular contraction, 57
- Chemical changes in tissues, 5
- Chemical composition of blood, 12
- Chemical substances in muscle, 32
- Children, temperature of, 379
- Chloral, its effect on cerebral functions, 163
- Cholesterin (*See* Bile)
- Cholic acid, 623
- Chondrin, 592
- Chorda tympani, stimulation of the: vascular effects, 166, 167; secreting effects, 212, 222; thermic effects, 379
- Chordæ vocales, 527
- Chordæ tendinæ, 122
- Chromatic aberration of the eye, 411
- Chyle, 245, 247
- Chyme, 238, 239, 241, 243
- Ciliary ganglia, 407
- Ciliary movement, 83
- Ciliary muscle, 405
- Ciliated cells, 89
- Circulation of the blood, 6; 96—179; effects of respiration on, 295; in asphyxia, 304; in the fœtus, 550
- Coagulation of the blood, 12, 14
- Coagulated proteids, 584, 591
- Cochlea, functions of, 453
- COLASANTI, effect of cold on guinea-pigs, 376
- Cold, effect of on temperature of the body, 375, 380; on rabbits and guinea-pigs, 376, 377
- Colon, 233
- Colour blindness, 425
- Colour sensations, 420
- Colour, 'pale,' 'rich,' 'deep,' 'bright,' 427
- Colour vision, 416, 424
- Colour of the retina, 414
- Colour of venous and arterial blood, 276, 280
- Compensating action for local disturbance, 179
- Composition of the animal body, 355
- Consciousness and intelligence, 473
- Consonants, 533
- Constriction of arteries (*See* Contraction)
- Contractile tissues, 31—84; chemical substances in muscle, 31; phenomena of muscle and nerve, 33; unstriated muscular tissue, 82; cardiac muscles, 83; cilia, 83; migrating cells, 84
- Contractile tissues, illustrated by the pendulum myograph, 37, 40; the magnetic interruptor, 47
- Contractility of the amœba, 1
- Contraction, law of muscular, 65; contractility of blood-vessels, 154, 160, 168, 170, 176
- Contraction of the walls of the stomach, 232
- Contraction (*See* Muscular Contraction)
- Contrast, visual sensations of, 433
- Convulsions in asphyxia, 302, 303
- Convulsive centre, 520
- Coordination of visual movements, 440
- Coronary arteries, 123, 151, 177
- Corpora Arantii, 123
- Corpora quadrigemina, 514, 521
- Corpora striata, 513, 521
- Corpuscles of the blood, 11, 12; their history, 24, 25, 26, 27, 98, 271
- Corpuscles, inorganic salts in, 13
- Corpuscles, in inflammation, 172
- Corpuscles, starch, 184
- Corpuscles, salivary, 183, 210
- Corpus luteum, 542
- CORTI, rods of, 454
- CORVISART, researches on digestion, 352
- Coughing, 309
- Cranial nerves, 392, 523
- Crassamentum, or blood-clot, 15
- Crura cerebri, section of, 158, 519, 521
- Crying, 310
- Currents (*See* Electric currents, Nerve currents)
- Curves, pulse (with tracings), 135, 136
- Curves, respiratory (with tracings), 256
- Cutaneous respiration, 313
- CYON, on vaso-motor centre, 158; diabetes, 338; urea in the liver, 351
- CZERNAK, effects of chorda stimulation, 212
- DANILEWSKY, on pancreatic juice, 203
- DEAHNA, on urari stimulation, 163; blood-pressure, 178
- Death, 489; death agony, perspiration in, 315
- Decidua, 546
- Decomposition of proteids, 588, 590
- DEEN, VAN, on the spinal cord, 488
- 'Deep' colours, 427
- Defecation, 233
- Deglutition, 225
- DEMTSCHENKO, secretion of tears, 448
- DENTS, on coagulation of the blood, 17
- Dentition, 560
- Depressor nerve, 162
- Derived proteids, 591

- Detrusor urinæ, 327
 Dextrin, 184, 185, 599
 Dextrose, 596
 Diabetes, 337, 339, 376
 Diabetic centre, 520
 Diagrams: of pendulum myograph, 37, 40; muscle-curves, 39; nervous impulses, 42; the magnetic interruptor, 47; non-polarisable electrodes, 48; muscle-nerve preparations, 60, 79; illustrating electrotonus, 61; simplest forms of a nervous system, 85; blood-pressure, 99, 116; apparatus for investigating blood-pressure, 100; kymograph, 103; Ludwig's stromuhr, for measuring velocity of flow of blood, 104; Marey's tambour, with cardiac sound, 117; Fick's spring manometer, 120; curves of pressure in cavities of heart, 121, sounds of the heart, 126; pulse-curves, 133; cardiac inhibition, 144, 152, 153; cervical and thoracic ganglia of rabbit, 148; of dog, 149; submaxillary gland of dog, 207; secretion of pancreatic juice, 216; respiratory movements, 256; apparatus for taking tracings of movements of air in respiration, 257, 258; Ludwig's mercurial gas-pump, 269; blood-pressure curves and intra-thoracic pressure, 298; Purkinje's figures, 431, 432; muscles of the eye-balls, 439; the horopter, 443; areas of spinal nerves, 481, 482; cerebral convolutions, of the dog, 501; of man, 502, 503; the larynx, 528
 Diaphragm, its action, 115, 259, 262, 288, 291
 Diastole of heart, length of, 119
 Dirotic pulse-wave, 135, 136
 Dietetics, 333
 Diet of an animal, normal, 357
 Digestion, tissues and mechanisms of, 7, 183—252; saliva, 183; gastric juice, 188; bile, 195; pancreatic juice, 198; succus entericus, 204; secretion of digestive juices, 205; muscular mechanism, 224—237; changes of food in alimentary canal, 237; absorption of products, 244; decomposition of proteids, 588
 Digestive secretion, mechanism of, 206
 Dilation of blood-vessels, 155, 175, 210, 215
 Dioptric mechanisms of sight, 397, 410
 Distribution of blood in the body, 31
 Diuretic drugs, 323
 Divers, respiration of, 304
 Dock, on glycogen, 332; on sugar in urine, 339
 Dog, quantity and distribution of blood in the, 30; arterial pressure, 102, 106, 153, 298; velocity of the circulation, 112, section of vagi, 147; cervical and thoracic ganglia (diagram), 149; saliva, 187; bile, 196; pancreatic juice, 198; submaxillary gland (diagram), 207; vomiting, 237; blood-crystals, 271, 282, 283; perspiration, 315; cerebral convolutions (diagrams), 501
 DOUGLASS, on blood-circulation, 106; sounds of the heart, 127
 DONDENS, length of the cardiac systole, 119, 130; pulse-waves, 133; inhibition of heart-beat, 144; lung-pressure, 255; movements of the eye-balls, 437; the rapidity of mental operations, 522
 Double pulse, 137
 Drowning, 304
 DU-BOIS REYMOND, pendulum myograph, 38; on muscle-currents, 52; muscular contraction, 53; muscle and nerve, 78, 81
 DUCHENNE'S experiments on respiratory movements, 261
 DUMAS, on nutrition, 341
 Duodenum, 230, 231, 236, 240
 DURHAM, sleep, 564
 Dyspepsia, 563
 Dyspeptone, 202
 Dyspnœa, 259, 289, 293, 295, 302, 303, 308
 Ear, the, 450
 ERSTEIN, on pepsin, 220
 ECKHARD, nervi erigentes, 165; action of submaxillary ganglion, 208; on secretion of saliva, 214; diabetes, 338; morphia diabetes, 339; spinal cord, 479; cerebral convolutions, 504; the cerebellum, 519
 Ectodermic cells, 85
 EDGREN, movements of the pupil, 407
 EDWARDS, W., respiratory changes, 265, 286, 310
 Eel, caudal vein, 155; iris, 406; contraction of the pupil, 406
 Efferent impulses in secretion of saliva, 90, 210; vomiting, 235; in reflex action, 472
 Egg-albumin, 573
 Elastin, 594
 Electric currents of nerve and muscle, 48, 79
 Electrodes, non-polarisable, illustrating nerve-currents (diagram), 48
 Electrotonus, 59—65, 78
 Emetics, effect of, 237
 EMMINGHAUS, movements of chyle, 249
 Emotions causing micturition, 329
 Endo-cardiac pressure, 115; Fick's spring manometer, 120; curves of pressure in cavities of heart, 121; in left ventricle and aorta, 122
 Endodermic cells, 86
 Energy of the body (income and expenditure), 369; muscular, 368
 ENGELMANN, on muscle-currents, 53; automatic action of ureter, 90; ciliary movement in the frog, 84; peristaltic movements, 230
 Entoptic phenomena of sight, 412
 Epiglottis, 226
 Epithelium cells, 183, 205, 211, 247, 324, 326, 345
 Erect posture, 536
 Ergot, its effect on peristaltic action, 230

- F**
FRISMANN, on cutaneous secretion, 315
E
Erectation, 239
Erythrogranulose, 185
ESTOR, seat of oxidation in respiration, 284
Eustachian tube, 451
Excretion of urine, 317; of milk, 344; of nitrogen in muscular exercise, 370 (*See* Defecation, Micturition)
Excretory tissues, 4, 5
Exhaustion, muscular, 76
EXNER, on reflex actions, 478; on the rapidity of mental operations, 521
Expiration, 254, 258; movements in, 262, 283, 297, 301
Explosives (voice), 534
Extractives in muscular tissues, 34
Eye, the, (*See* Sight)
Eye-balls, movements of the, 437, 514
Facial respiration, 264
Fæces, 235, 243
Fainting, 147
Fallopian tubes, 542, 545
Falsetto voice, 531
Fat, history of, 340, 356
Fat of milk, 344
Fats, their derivatives and allies, 599
Fats in serum, 12; action of bile on, 193; of pancreatic juice, 203; digestion of, 238, 240, 241, 250
Fatty degeneration, 562
Fatty food, effects of, 363, 364, 384
Fauces, 225, 226, 236
FECHNER'S formula of visual sensations, 418
Feeling and Touch, 462
Ferment, amylolytic, 222
Ferments, organized and unorganized, 186; saliva, 186; gastric juice, 193; of pancreatic juice, 199, 219; in the small intestine, 242
FERNET, on respiration, 310
FERRIER, on the brain, 506, 512, 516, 517; cerebral convolutions of the dog and man (diagrams), 501, 502, 503
Fibrin, 12, 15, 16, 19, 24, 81, 190, 192, 199, 581, 591
Fibrinogen, 581
Fibrinoplastin, 12, 580
FICK, on blood-circulation, 119, 121; spring manometer (diagram), 120; pressure in cavities of heart (diagram), 121; urea and muscular exercise, 369; muscles of the eye-balls, 440; spinal cord, 488
Flatulency, 239
FLAISCHL, nervous irritability, 71
FLOURENS, on the respiratory centre, 289; on the brain, 515
Fetus (*See* Embryo)
Food, action of bile and pancreatic juice on, 197, 198
Food, fattening diet, 364; potential energy of food, 367, 383
Food, glycogen produced by, 332, 335
Food, its effect on the stomach, 232; absorption by diffusion, 250; effects of carbohydrate, 363
Food, its changes in the alimentary canal, 237
Food, tissues and mechanisms of digestion, 183—252; changes of food in the alimentary canal, 237; absorption of products of digestion, 244
Force of heart-beat, 130
FORBYCE, Dr, effect of heat, 375
Formic acid, 600
FRANKLAND, on the potential energy of food, 367
Frequency of heart-beat, 130
FREICHS, on digestion, 252
FREUSBERG, on reflex actions, 477
Frigorific nerves, 379
FRITSCH, cerebral convolutions of the dog (diagram), 501
Frog, experiments on the; blood, 26; nerves, 33, 35, 36, 50, 71, 73, 91; the rheoscopic frog, 50, 52; muscle currents, 52; ciliary movement, 84; lymphatic heart, 89, 93; circulation in web of foot, 97; heart, 141, 142, 143, 147; contractility of arteries, 154, 155; blood-vessels, 172; capillary circulation, 179; cutaneous respiration, 313; contraction of the pupil, 406; visual purple in, 416; spinal cord, 471, 487; lymph heart, 479
Frog, brainless, its behaviour, 471, 489
Functional activity, its influence on muscular irritability, 76
FUNKE, on succus entericus, 204; sugar in blood and urine, 250; respiration, 301; quantity of perspiration, 312
GALABIN, Dr, diagrams of pulse-curves, 135, 136
Galvanic current, its effect on muscular contraction, 68
Ganglia, 89, 93, 143, 146, 228, 232, 391; cervical and thoracic, of rabbit and dog (diagrams), 148, 149
GARROD, on pulse-waves, 134; heart-beat, 177; quantity and flow of blood, 177
Gases, in eructation, 239; in the large intestine, 243; in the blood, 267
Gases in urine, 319
Gases, poisonous, respiration of, 307
Gas-pump, mercurial, Ludwig's (diagram), 269
GASKELL, W. H., contraction and dilation of arteries, 167
Gastric juice, 183, 188, 214, 238; artificial, 189, 557
Gastric compared with pancreatic digestion, 201
Gelatin, 593, as food, 365
GERLACH, on cutaneous respiration, 313
Gestation, 553
Giddiness, 497
GILBERT and LAWES, on the formation of fat, 341, 363
Glands, submaxillary, secretion of saliva, 206; submaxillary of dog (diagram) 207;

- gastric, 220; salivary, 221; of rabbit, 222; secreting sweat, 314; mammary, 344; lachrymal, Meibomian, 447
- GLISSON, on muscular contraction, 36
- Globin, 278
- Globulin, in muscular tissue, and saliva, 33, 184, 279, 579, 591
- Glomeruli, renal, 321
- Glottis, its action in respiration, 264, 289, 528; contractions of the (diagram), 528
- Glutin, 593
- Glycerine, 604
- Glycerinphosphoric acid, 607
- Glycocholic acid, 624
- Glycin, 619
- Glycogen, 330, 549, 598
- GMELIN, researches on digestion, 252
- GOLTZ, on vaso-motor actions, 159, 168; movements of the œsophagus, 230, 233; defæcation, 233, 234; movements of lymph, 249; micturition, 328; reflex actions, 477; lymph-hearts, 479; the cerebral convulsions, 526; menstruation, 544; impregnation, 545
- Goose, bile of, 196; blood-crystals, 272
- Graafian follicle, 542
- Granulose, 185
- GREHANT, on urea, 350
- Grey matter of the spinal cord, 486
- Growth, phases of life, 561
- GRÜTZNER, on pepsin, 220
- GSCHIEDLEN, on the colouring power of blood, 31; on the origin of urea, 350, 351
- Gnanin, 618
- Guinea-pig, saliva of the, 187; blood crystals, 271; effect of cold on, 376
- Gustatory buds, 460
- GYERGYAI, absorption of proteids in digestion, 250
- HABERMAN, on proteids, 590
- Hæmadromometer of Volkmann, for measuring blood-pressure, 103
- Hæmatachometer, for measuring blood-pressure, 105
- Hæmatin, 278, 279
- Hæmatoidin, 29
- Hæmoglobin, 13, 21, 29, 223, 271, 278, 281
- Hæmorrhage, effects of, on vascular mechanism, 174
- HÆRLIN, on paralbumin, 575
- HALES, Dr Stephen, circulation of blood, 99, 179
- HALFORD, sounds of the heart, 127
- HALLER, on muscular contraction, 36; on physiology of muscle and nerve, 81; respiratory movements, 261
- HAMBERGER'S model of respiratory movements, 261
- HAMMARSTEN, coagulation of blood, 21; gastric juice in new-born animals, 557
- Hearing, 449
- Heart, the, 113—131; phenomena of the normal beat, 113; curves of pressure in cavities of heart, 121; mechanism of the valves, 122; sounds of the heart, 126; its failure before death, 567
- Heart-beat, 89, 90; normal, 96, 99, 102, 109, 110, 113, 122; variations in, 129, 140—153, 305, 321, 549
- Heart-murmurs, 127
- Heart of the babe, 557
- Heart of the frog, 93
- Heat, loss of energy from, 368
- Heat, sources and distribution of, 372
- Heat, varying production of, 375
- Hedgehog, blood-crystals of the, 272
- HEIDENHAIN, on pancreatic digestion, 200; mechanism of digestive secretion, 203, 213; researches on digestion, 252; on renal secretion, 325; on nutrition, 370; bodily heat, 378, 379; lymph-hearts, 479
- HELLER, movements of chyle, 248
- HELMHOLTZ, on muscular contraction, 58; velocity of nervous impulses, 81; loss of energy from heat, 373; dioptric mechanisms, 413; colour sensations, 422; the horopter, 443; vision and musical sounds, 470
- HELMONT, VAN, on carbonic acid gas, 310
- Hemipeptone, 202
- HENSEN, on auditory hairs, 455
- Hepatic artery, and the secretion of bile, 223; hepatic cells, 4, 223, 224, 330, 336
- Herbivorous animals, nutrition of, 365
- HERING, respiratory action of *vagus*, 290; nervous mechanism of respiration, 292; colour sensations, 424; sensations of temperature, 465
- HERMANN, on muscular contraction, 53; rigor mortis, and electrical theory of muscle, 74, 79, 81; respiration of muscle, 81
- HERZEN, inhibition of reflex action, 474
- HERZENSTEIN, secretion of tears, 448
- HEYNSIUS, pigments of bile, 196
- Hiccough, 309
- Hippuric acid, 354
- HIRSCH, on the personal equation, 522
- HIRSCHMANN, on visual sensations, 419
- HITZIG, on the cerebral convulsions of the dog (diagram), 501, 504; cerebellum, 517; vertigo, 518
- HLASIWITZ, on proteids, 590
- HOLMGREN, movements of the pupil, 407, 409; electric currents of the optic nerve, 413
- HOOK, on artificial respiration, 310
- HOPPE-SEYLER, on the composition of blood, 12, 13, 14; on bile, 197; hæmoglobin, 280; respiration, 310; nutrition, 362; analysis of proteids, 572
- Horopter, the, 443
- Horse, blood-circulation in the, 19, 22, 25, 26, 99, 102, 106, 111, 116, 119; saliva, 187, 238; blood-crystals, 271; locomotion, 538
- HORVATH, death from extreme heat, 380
- HOUCHEEST, VAN BRAAM, peristaltic action, 229

- HÜFNER, on influence of bacteria in digestion, 201
- HUTCHINSON, vital capacity of the lungs, 255
- HUXLEY, blood corpuscles, 28
- Hydra, 32, 85
- Hydraulic principles of blood circulation, 107
- Hydrozoa, ciliary movement in, 84, 86
- Hydruria, or excessive renal secretion, 322
- Hyperpnœa, 302
- Hypoglossal, vaso-motor action of the, 156
- Hypoxanthin, 348, 617
- Ileo-cæcal valve, 230, 233, 243
- Impregnation, 545
- Impulses, nervous, 86; efferent and afferent, 90; afferent, 389; conduction of by the spinal cord, 483; nervous, in respiration, 289; sensory and motor, 95
- Income and outcome of diet, 358
- Income of energy, 366
- Incontinence of urine, 329
- Indican in urine, 319, 625
- Indigo, 626
- Indigo-carmin, excretion of, 325
- Indol, 201
- Induction-machine, 45; induction-shock, effects of, 39, 58, 67, 68, 77, 144
- Inert layer in capillary circulation, 98
- Infants, temperature of, 379
- Inflammation, its effects, 172, 381
- Infusoria, ciliary movement in, 84
- Inhibition, 93; of heart-beat, 144—153, 176; of peristaltic action, 229; of saliva, 214; of reflex action, 474; parturition, 554
- Injection of blood, effects of, 175
- Inosit, 598
- Insensible perspiration, 312
- Inspiration, mechanics of, 254, 258, 259; nervous mechanism of, 288; effects on circulation, 297; in asphyxia, 302
- Integration of fundamental tissues, 6
- Intercostal muscles, their action in respiration, 261, 263
- Intestine, large, 233, 243
- Intestine, small, 227, 240
- Irradiation of visual sensations, 433
- Irritable tissues, 5, 6
- Irritability of nerve and muscle, 32, 35, 36, 64, 72, 75
- Isthmus faucium, 225, 226
- Jaborandi, its effect on heart-beat, 145
- JACOBSON, on blood-pressure, 106
- JAFFÉ, urobilin in urine, 30; pigments of bile, 196
- Jaundice, 224
- JONES, WHARTON, blood-corpuscles, 28
- JÜDELL, composition of red corpuscles, 13
- Judgments, visual, 444; auditory, 457; tactile, 466
- Juices, digestive, 183—224
- Jumping, 532
- Katelectrotonus, 61, 62, 64, 65
- KEMMERICH, on the secretion of milk, 345
- KENDAL, on cutaneous secretion, 315
- KENDALL, vaso-motor action, 168, 169
- Keratin, 594
- Kidneys, secretion by the, 317—329, 350
- KLEIN, origin of white blood-corpuscles, 29
- KNOCK, bodily heat, 379
- KNOLL, on the corpora quadrigemina, 514, 516
- KOHLSCHÜTTER, sleep, 565
- KÖLLIKER, red corpuscles, 28, 29; succus entericus, 204
- KORNER, on uterine contractions, 555
- Kreatin, kreatinin, 348, 349, 615, 619
- KRONECKER, on muscular contraction, 67, 78; functional activity of muscles, 77
- KÜHNE, on the chemistry of muscle, 34, 82; gastric juice, 194; pancreatic juice, 199; proteids, 201, 203; mechanism of salivary secretion, 213; secretion in the pancreas, 218; visual purple of the retina, 415
- KUPFFER, on endings of nerves in salivary glands, 212
- KÜRSCHNER, on heart-beat, 114
- Kymograph for recording arterial pressure (diagram), 103
- Kynurenic acid, 618
- Labour, loss of energy by, 368
- Labour-pains, 554
- Laboured respiration, 254, 259, 262, 263, 288
- Lachrymal glands, 447
- Lacteals, 246
- Lactic acid, 605
- Lactose, 597
- LAGRANGE, on respiration, 310
- LANDOIS, on blood-circulation, 119; pulse-waves, 134; cerebral convolutions, 504
- LANGENDORF, inhibition of reflex action, 475
- LANGLEY, salivary secretion, 213
- Lardacein, 589, 591
- Laryngeal nerve, superior, in respiration, 291; in voice, 530; inferior, in respiration, 292; in voice, 530.
- Laryngeal respiration, 264
- Laryngoscope, 264
- Larynx, 225, 528; diagrams of the, 528, 532
- LATSCHENBERGER, on urari stimulation, 163; blood-pressure, 178; respiration, 301
- Laughing, 310
- Laurostearic acid, 601
- LAVOISIER, on respiration, 310
- LAWES and GILBERT, on the formation of fat, 341, 363
- LEA and KÜHNE, secretion in the pancreas, 218
- Lecithin, 609
- LEGG, WICKHAM, on diabetes, 339
- Leucin, 201, 202, 242, 351, 619

- LEUCWENHOEK**, capillary circulation, 179
Levatores costarum, 262
LIEBERMANN, pigments of bile, 196
LIEBIG, on formation of fat, 341; nutrition, 368, 371, 386
Life, the phases of, 556
Lingual nerve, 156, 206
LISTER, J., coagulation of the blood, 22, 24; vaso-motor action, 159
LIVING, movements of the eye-balls, 438
Liver, secretion of bile, 222; a source of sugar, 331; a source of heat, 373
Locomotor ataxy, 469
Locomotor mechanisms, 536
LORET, instrument for measuring blood-pressure, 106
LOVEN, constriction and dilation of arteries, 164
LOWER, on respiration, 310
LUCHSINGER, vaso-motor action, 168, 169; cutaneous secretion, 316; perspiration in the cat, 316
LUDWIG, on blood-circulation, 104, 106; sounds of the heart, 127; vascular mechanism, 179; mechanism of salivary secretion, 213; peristaltic action, 230; mercurial gas-pump (diagram), 269; respiration, 310; renal secretion, 325; temperature of submaxillary gland, 379
Lumbar cord, 543, 553
Lungs, the: mechanics of pulmonary respiration, 254; elastic force of, 255, 296; respiratory changes in, 281; loss of heat from, 374
Lunulae of heart-valves, 123
Lutein, 30
Lymph, Lymph-vessels, Lymphatic glands, 29, 32, 246, 247
Lymph-hearts of the frog, 89, 479
Lymphatic system in infancy and youth, 559
Magnetic interruptor (diagram), 47
MAGNUS on respiration, 310
MAJENDIE, on vomiting, 236; sensory nerves, 390; olfactory nerve, 459; the brain, 521
MALPIGHI, capillary circulation, 179
Malpighian bodies of the kidney, 317, 321
Mammary gland, 344
Manometer applied to blood-circulation, 99, 101, 120; to heart-beat, 144, 151, 152, 153 (*See* Diagrams)
Marching, 537
MAREY, on blood-circulation, 111; blood-pressure, 116, 119; pulse waves, 133; heart-beat, 151; Marey's tambour, (diagram) 117, 258; pneumograph, 256; locomotion of the horse, 538
Mastication, 225
MAYOW, on changes of air in respiration, 265; on oxygen, 310
MAXWELL, on colour-sensations, 421
Meat (*See* Dietetics, Nutrition)
Mechanical tissues, 5
Mechanism of digestive secretion, 206
Mechanisms of respiration, 253—310
Mechanisms of reproduction, 541
Meconium, 549
Medulla oblongata, 520; cardio-inhibitory centre, 147; respiratory centre, 288; vaso-motor centre, 157; centre for secretion of saliva, 210; for deglutition, 227; for movements of œsophagus and stomach, 230; for vomiting, 288; convulsive centre, 302; as a centre of co-ordination in the frog, 498; in the mammal, 477
Meibomian glands, 447
MEISSNER, plexus of the intestines, 90; peptic digestion, 202, 203; peristaltic action in digestion, 228; urea and urates in the liver, 351; hippuric acid, 354; peptones, 586
Menstruation, 542
Mental emotions producing perspiration, 315
Mercurial gas-pump, Ludwig, (diagram) 269
Mercury manometer applied to blood-circulation, 99, 107, 116, 144, 151 (*See* Diagrams)
Metabolic tissues, 4, 5
Metabolic products in urine, 320
Metabolic phenomena of the body, 330
Metabolism of the embryo, 548
Metabolites, nitrogenous, 610
Metapeptone, 202
MEYER, LOTHAR, on respiration, 310
MICHELLE, the cerebral convulsions, 505
Micturition, 327, 475
MIESCHER, on blood-corpuscles, 14; nuclein, 595; spinal cord, 485, 488
Migrating cells, 84
Milk, 299, 300; action of gastric juice on, 191, 194
Milk-sugar, 597
Minerals, action of gastric juice on, 189
MOLESCHOTT, normal diet of man, 358
Monkey, cerebral convulsions, 502
Morphia diabetes, 339
Mosso, changes in the circulation, 173; movements of the œsophagus, 231
Motor fibres, 156
Motor nerves, 87, 95
Mouth, its action in digestion, 238
Mucin, 592
Muciparous cells, 222
Mucous glands, 222
MÜLLER, J. J., researches on respiration, 283
MÜLLER, WORM, effects of bleeding, 174
MÜLLER, W., changes of air in respiration, 283
MÜLLER, J., on the senses, 470; on reflex actions, 525
Muscarin, its effect on heart-beat, 145
Muscle and nerve, 60, 70, 71, 78
Muscle currents in frog and rabbit, 52
Muscle-curves, diagrams of, 39, 44, 45
Muscles, 32—84; chemical substances in muscle, 32; glycogen in, 335; kreatin

- in, 349; respiratory changes in, 284; phenomena of muscle and nerve, 33; unstriated muscular tissue, 82; cardiac muscles, 83; cilia, 83; migratory cells, 84
- Muscles of defecation, 233
- Muscles of mastication and deglutition, 224, 225
- Muscles of micturition, 327
- Muscles of respiration, 259, 261, 263, 288
- Muscles of the eye-balls, 439
- Muscles of the fœtus, 549
- Muscles of the larynx, 528
- Muscular contraction:—shewn by the pendulum myograph, 37, 38; changes in a muscle during contraction, 52; electrical changes, 52; change of form, 55; physical changes, 56; chemical changes, 57; law of contraction, 65; circumstances affecting its amount and character, 68
- Muscular energy, sources of, 369
- Muscular fibre cells, 86
- Muscular fibres in arteries, 154
- Muscular mechanisms, 7
- Muscular mechanisms of digestion, 224—237; of respiration, 253—310; mastication, 225; deglutition, 225; peristaltic action, 227; movements of the œsophagus, 230; of the stomach, 232; of the large intestine, 233; vomiting, 235
- Muscular mechanisms, Special, 527
- Muscular irritability, 35, 36, 62
- Muscular sense, 468
- Muscular sound, 56
- Muscular tissues, 4
- Musical sounds, nature of, 453
- Myograph, pendulum (diagram), 37, 40
- Myosin in muscular tissues, 33, 73, 81, 581
- Myristic acid, 601
- Native albumins, 573
- Nausea, 235
- Negative variation, in nerve-currents, 50; of muscle-currents, 53
- Nerve and muscle, phenomena of, 35
- Nerve-currents, natural, 48; illustrated by non-polarisable electrodes (diagram), 48; negative variation, 50, 53
- Nerve-roots, 87
- Nerves, accelerator, 148, 177; experiments with pendulum myograph, 38; irritability of, 71, 72; cardiac, of the dog, 149; thermogenic, 377; frigorific, 379
- Nerves, cranial, 392, 523
- Nerves, their effect on constriction and dilation of arteries, 155
- Nerves employed in defecation, 233
- Nerves in connection with striated muscles, 32
- Nerves, their influence on the secretion and ejection of milk, 346
- Nerves of mastication and deglutition, 225
- Nerves of sight, 407
- Nerves of touch, 462, 468
- Nerves, renal, 322
- Nerves, sensory, 389
- Nerves, spinal, 390, 481
- Nerves, splenic, 347
- Nerves, vaso-motor, 156
- Nervi erigentes, 165, 167
- Nervi mesenterici, 147
- Nervous action in the œsophagus, 230
- Nervous action in vomiting, 236
- Nervous influences on peristaltic action, 228
- Nervous impulses, curves illustrating their velocity, 42; changes in the nerve during their passage, 46, 59, 66, 78
- Nervous irritability, 63, 64
- Nervous mechanism for secreting digestive juices, 206, 214, 216
- Nervous mechanism of the gastric movements, 232
- Nervous mechanism of perspiration, 315
- Nervous mechanism of respiration, 288
- Nervous system, 6, 7, 8; simplest forms of (diagram), 85; its influence on heart-beat, minute arteries and capillaries, 142; its influence on nutrition, 381; in infancy and youth, 559
- Nervous tissues, properties of, 4, 85—95; metabolism of, 349
- Nervous tissues, general properties of, 87
- NEUMANN, red corpuscles, 28
- Neurin, 609
- Neutral fats, 603
- Nicotin, its effect on heart-beat, 146; peristaltic action, 230
- Nitrogen of inspired and expired air, 265
- Nitrogen, quantity in arterial and venous blood, 262
- Nitrogen, its relations in the blood, 281
- Nitrogenous crystalline bodies in urine, 318
- Nitrogenous food, 368
- Nitrogenous metabolism, 361
- Nitrogenous metabolites, 610
- Nud vital*, 289
- Non-nitrogenous metabolism, 363
- Non-polarisable electrodes (diagram), 48
- Normal diet, 357, 385
- Nostrils, their action in respiration, 264, 289
- NOTHNAGEL, on the brain, 513, 518
- Nuclein, 595
- Nutrition, 330; production of glycogen, 332; of the embryo, 547
- Ocular spectra, 434
- Odour of the breath, 266
- OEHL, movements of the pupil, 409
- œsophagus, movements of, 230, 235
- Old age, 562
- Oleic acid, 602
- Olein, 604
- Olfactory organs, 458
- OPPLER on renal secretion, 350
- Optic thalami, 513, 521

- Osmosis, 97
 Otic ganglia, 93
 Ovaries, 542, 545
 Ovum, 541, 545, 547, 567
 OWSJANNIKOW, vaso-motor centre, 158, 165; on reflex actions, 477
 Ox, saliva of the, 187; bile, 196; blood-crystals, 272
 Oxalic acid, 607
 Oxidation, seat of, in respiration, 284
 Oxygen inhaled in respiration, 253, 254, 265, 267; quantity and condition in arterial and venous blood, 268, 270, 280, 295; its entrance into the lungs in respiration, 281, 287: the cause of dyspnoea, asphyxia, and apnoea, 306
 Oxygen tension, 282, 287
 Oxyhæmoglobin, 78, 273, 275
- Palate in deglutition, 225, 226
 'Pale' colours, 427
 Palmitic acid, 602
 Palmitin, 603
 Pancreatic digestion, 242
 Pancreatic juice, 183, 198, 216, 217, 240, 242, 342
 Papillary muscles, 122
 Paraglobulin, 18, 580
 Paralytic saliva, 214, 217
 Parapeptone, 191, 198, 200, 202, 241
 PARINAUD, bodily heat, 378
 PARKES, on urea and muscular exercise, 369
 Parotid saliva, 187, 212
 Parturition, 553
 PASCHUTIN, on the action of saliva, 186; movements of lymph, 249; inhibition of reflex action, 474
 Pendulum myograph (diagram), 40; diagrams obtained by it, 39
 Penicillium, 343, 366
 Penis, mechanism of erection, 166, 545
 Peptic digestion, 190, 202
 Peptic glands, 220
 Pepsin, the ferment of gastric juice, 198, 201, 220
 Peptone, 191
 Peptones in gastric juice, 188, 189
 Peptones, 197, 200, 202, 239, 585, 591
 Perceptions, tactile, 462, 466; visual, 427, 432
 Periodicity in the phenomena of the body, 563
 Peripheral resistance in blood-circulation, 110, 152—171, 128, 137, 172, 177
 Peristaltic contractions, 89, 90, 93; in defæcation, 234; in digestion, 227; in the œsophagus, 230; in the stomach, 232
 Perspiration, nature and amount of, 311; nervous mechanism of, 315; average loss by, 359, 374
 PETTENKOFER, on changes of air in respiration, 266; on nutrition, 360, 363, 370, 386; sleep, 565
 Pettenkofer's test, 623
- PFLÜGER, nervous irritability during electrotonus, 61, 71, 82; endings of nerves in salivary glands, 212; inhibition of peristaltic action, 229; pump for extracting gas from blood, 268, 269; hæmoglobin, 278; seat of oxidation in respiration, 284; respiratory changes in tissues, 286, 310; spinal cord, 473; sleep, 565
 Pharynx in deglutition, 225; vomiting, 231, 235
 Phases of life, 556
 PHILIPPEAUX, on union of sensory and motor nerves, 393
 Phosphorus as an element of food, 366
 Phrenic nerve, its effect on respiration, 288
 Phthisis, cold sweats in, 315
 Pig, saliva of the, 187; bile, 196; blood-crystals, 272
 Pigments in bile, 223; in urine, 318, 325
 Placenta, 546, 549, 550
 PLANER, gases of intestine, 242
 Plasma of the blood, 11, 12, 13, 15, 19
 Plasmine, 17, 19
 PLATEAU, on after images, 427
 Plethysmograph, for measuring changes in the circulation, 173
 PLÓSZ, absorption of proteids in digestion, 250
 Pneumogastric nerve, its influence in respiration, 289
 Pneumographs, Marey's and Fick's, 256, 258
 POISEUILLE, application of the mercury manometer to blood-circulation, 102
 Poison, effect of urari, 35, 338; carbonic oxide, 339
 Polyuria, or excessive renal secretion, 322
 Pons Varolii, 519, 521
 Potential energy of food, 367
 Predicrotic pulse-wave, 135, 136, 137
 Pregnancy, 546
 Pressure, blood, 99—179, 294 (*See* Blood pressure)
 Pressure of air in respiration, 308
 Pressure, sensations of, 463
 PREYER, on blood-corpuscles, 29; on hæmoglobin and hæmatin, 279, 280; sleep, 565
 PRIESTLEY on respiration, combustion and oxygen, 310
 Propionic acid, 601
 Protective mechanisms of the eye, 447
 Proteid food, metabolic effects of, 363, 383
 Proteids, 571, 572; action of gastric juice on, 189, 194; action of pancreatic juice on, 200; changes in stomach, 238; in the intestine, 242; absorption of in digestion, 250; as sources of fat, 341
 Proteolysis, digestive, theory of, 202
 Protoplasm, properties of, 1, 85, 90; in adipose tissue, 340; spinal, 473
 Protoplasm of embryonic tissues, 548

- PROUT**, on digestion, 252
Ptyalin of saliva, 186, 194
Puberty, 542, 560
Pulmonary respiration, mechanics of, 254
Pulsation of the brain, 295
Pulse, the, 103, 106, 131—140; sphygmograph tracings of pulse-waves, 135, 136; predicrotic and dicrotic waves, 138
Pulse-waves, primary, secondary, and reflected, 131—140, 143, 304
Pulsus venosus, 295
Pump action of the heart, 109, 111, 131, 136
Pupil of the eye, its movements, 405, 514
Purgative action of salts, 251
PURKINJE'S figures, 431, 432; on the effects of galvanic currents on the brain, 518
Purple, visual, 414
Purpurin in urine, 319
Pylorus, 230, 232, 236, 238, 239, 241
Pyrexia, 376
Pyrosis, 236
Python, temperature of, 372
- QUETELET**, phases of life, 557
Quinine, action of on reflex action, 475
- Rabbit**, quantity and distribution of blood in the, 30; muscle currents, 52; arterial pressure, 102, 106; circulation, 114; heart-beat, 147; cervical and thoracic ganglia (diagram) 148; inhibition of heart-beat, 152; contractility of the arteries of the ear, 154; stimulation of depressor nerve, 162; saliva, 187; submaxillary gland, 222; blood-crystals, 272; blood-pressure in respiration, 298; section of spinal cord, 338; effect of cold on, 376, 377; movements of the pupil, 409; spinal cord, 487
Radial artery, pulse-wave in, 135
RANKE, on distribution of blood in the body, 31; perspiration, 313; nutrition, 367, 369
RANSOME, Dr A., power of gastric juice, 193; movement of ribs in respiration, 260
Rat, saliva of the, 187; blood-crystals, 272
Reaction period, 521
Rectum, in defecation, 233
Red corpuscles of blood, their chemical composition, 13; their fate, 29, 271
Reflex actions, 90
Reflex actions, the spinal cord as a centre of, 471; characters of, 472
Reflex actions, inhibition of, 474
Reflex actions, parturition, 553
Reflex centres, 471, 514, 520
Reflex inhibition of heart-beat, 146
Reflex micturition, 329
Regeneration of tissues, 541
REGNAULT and **REISET** on cutaneous respiration, 313; on nutrition, 386
REICH, secretion of tears, 448
Renal secretion, 317
Rennet, 195
Reproduction of the amoeba, 3
Reproduction, tissues and mechanisms of, 5, 541
Resonants (voice) 534
Respiration of the amoeba, 3, 4
Respiration, tissues and mechanism of, 253—310; mechanics of pulmonary respiration, 254; apparatus for taking tracings of movements of air (diagram), 257, 258; changes of air in, 264; changes in blood, 267; in the lungs, 281; in the tissues, 283; nervous mechanism, 288; effects on the circulation, 288; effects of changes in the air breathed, 302; modified respiratory movements, 308
Respiration, cutaneous, 313
Respiration as a regulator of temperature, 374
Respiration of the fœtus, 550
Respiration, failure of before death, 567
Respiratory centre, 293, 294
Respiratory curves, tracings of, 162
Respiratory mechanisms, 7
Respiratory muscles, 91, 93
Rest, muscular exhaustion restored by, 77
Retina, colour of the, 414
Retching, 235
Rheometer of Ludwig, for measuring blood-pressure, 104
'Rheoscopic Frog', 50, 53, 127
Rhythm of heart-beat, 131, 142; of respiration, 256, 265, 289, 291, 293, 301; in asphyxia, 302
Ribs, movement in respiration, 260, 262
'Rich' colours, 414
Rigor mortis, 72, 73, 81, 305, 373, 568
RINGER, on diabetes, 339; daily variation in the temperature of the body, 380
RITTER'S tetanus, 66
RITTER-VALLI, law of irritability of nerves, 72
RÖHRIG, on perspiration, 314; effect of cold on rabbits, 376; urari poisoning, 376
ROMANES, on contractile tissues, 67
ROSENTHAL, respiratory function of vagus, and theory of nervous mechanism of respiration, 292; on reflex actions, 478
RUGE, gases in the large intestine, 243
Running, 538
RUTHERFORD, vaso-motor nerves of stomach, 215
- SAIKOWSKY**, diabetes, 339
ST PIERRE and **ESTOR**, seat of oxidation in respiration, 284
Saliva, 183—188; its action on starch, 184, 194; quantity of, 206; action of submaxillary saliva, 206, 226, 238; in vomiting, 235; relation to taste, 461
Saliva of infants, 557
Salivary cell, nutrition of the, 381
Salivary corpuscles, 185
Salts, as food, 366
Salts, in bile, 196; in blood, 13; in urine,

- 317; absorption into blood and urine, 251
- SAMUEL, effect of cold on rabbits, 377
- SANDERSON, BURDON, dirotic pulse-wave, 139; recording stethometer, 256; cerebral convolutions, 505
- Saphena artery of the rabbit, its contractility, 155
- Sarkin, 617
- Scaleni muscles, 261, 288
- SCHAFER, red corpuscles, 28
- SCHARLING, on cutaneous respiration, 313
- SCHECH, on the larynx, 531
- SCHNEIDER'S experiment on sight, 401
- SCHERER, paralbumin and metalbumin, 575
- SCHIFF, mechanism of digestive secretion, 208; on secretion of bile, 223; movements of the œsophagus, 231; vomiting, 235; spinal cord, 483; functions of the brain, 519
- SCHMIDT, A., fibrinoplastin and fibrinogen, 19, 25, 26; red corpuscles, 28; relations of neutral salines and of gastric juice, 192; albumins, 575
- SCHMIDT and BIDDER, analysis of chyle, 246; absorption of fat in digestion, 241; researches on digestion, 252
- SCHMIDT, C., composition of blood, 12, 13; on lardacein, 589
- SCHMIEDEBERG, cardiac accelerator nerves, 149; hippuric acid, 354
- SCHULTZE, MAX, on dimensions of retinal cones, 419; olfactory cells, 458
- SCHULTZEN, on urea, 352
- SCHUTZENBERGER, on proteids, 590
- SCHWANN, researches on digestion, 252
- Sciatic nerve, vaso-motor action of, 155, 156, 166, 168
- Secretion by the skin, 311—316
- Secretion by the kidneys, 317
- Secretion by the renal epithelium, 324
- Secretion of milk, 344
- Secretions, digestive (*See* Saliva, Bile, Pancreatic juice)
- Secreting tissues, 4, 5
- Semen, 545
- Semilunar valves of the heart, 123, 125, 126
- Sensations, auditory, 452
- Sensations, tactile, 463
- Sensations, visual, 413
- Sense, muscular, 468
- Sense-organs, 395
- Sensible perspiration, 312
- Sensitive cells, 87
- Sensory fibres, 156
- Sensory nerves, 86, 95, 389
- SEQUIN, on perspiration, 311
- Serum, its chemical composition, 12, 14
- Serum-albumin, 574
- SETSCHENOW, inhibition of reflex action, 474 (diagram)
- Sexual generation, 541, 545
- SHARPEY, sounds of the heart, 126
- Sheep's blood, 22, 106, 272; saliva, 187
- SHEPARD, hippuric acid, 354
- Sighing, 309
- Sight, 397—448
- Sight, protective mechanisms of the eye, 447
- Singing, 528
- SINITZEN, on trophic nerves, 382
- Sinus venosus, 143, 146
- Size, appreciation of, 444
- Size of the body; phases of life, 556
- Skeletal muscles, 156, 480, 536
- Skeleton, growth of the, 561
- Skin, 5, 6; absorption by the, 316; secretion by the, 311—316; secretion by the, and kidneys, 317
- Skin, loss of heat from the, 373
- Skin, terminal organs of the, 462
- Sleep, 563
- Smell, 458
- Sneezing, 309
- SNELLEN, inflammation of the eye, 382
- Sobbing, 309
- Solidity, judgment of, 445
- SOLTMANN, cerebral areas in the newly-born, 559
- Sound, the voice, 527
- Sounds given by muscles, 56
- Sounds, musical, 453
- SPALLANZANI, researches on digestion, 252; respiratory changes in the tissues, 287
- Special muscular mechanisms, 527
- Spectra of hæmoglobin, 271, 273; hæmatin, 278, 279
- Speech, 532
- Spermatozoon, 84, 541
- Spherical aberration in the eye, 410
- Sphincter vesicæ, 237
- Sphygmograph, 115, 130, 135, 140
- SPIESS, temperature of submaxillary gland, 379
- Spinal cord, section of, effect on blood-pressure, 157, 166; its action on respiration, 288; of rabbit, section of, 338; as a centre of automatic action, 478; as a conductor of impulses, 480; parturition, 553
- Spinal nerves, 89, 90; roots of, 390
- Spirometer, 255
- Splanchnic nerve, vaso-motor action, 156, 161; relation to gastric secretion, 215; relation to peristaltic movements, 229, 232; and renal secretion, 323
- Spleen, the, 346
- Sporadic ganglia, 89
- SPRENGEL'S pump for extricating gas from blood, 268
- STANNIUS, experiments on heart-beat, 146
- Starch, action of saliva on, 184, 194, 238, 240, 335; action of gastric juice on, 189; corpuscles, 240, 335; action of pancreatic juice on, 199; as food, 363, 365
- Starvation, effects of, 356, 357
- Stasis in inflammation, 172, 173
- Statistics of nutrition, 355
- Stearic acid, 602

- Stearin, 604
 Stereoscope, 441
 Stethometer, recording, 256
 Stethoscope, 56
 Stimulation, impulses in nerves produced by, 86
 Stimulation of afferent nerves, effect on vaso-motor centre, 163
 Stimulation of the chorda tympani, 212, 229
 Stimuli, character of reflex actions dependent on the nature, 472
 Stimuli in aid of parturition, 554
 Stimulus, as affecting muscular contraction, 68, 76; in unstriated muscles, 82
 STOKES on the spectra of hæmoglobin, 310
 Stomach, secretion by, 214; action of gastric juice on the, 224; its movements in digestion, 232; its action in vomiting, 235; its action on food, 238; digestion in the, 238, 239 (*See Digestion*)
 STRASSBURG'S researches on respiration, 282, 283, 285
 STROGANOW, oxygen in the lungs in respiration, 282
 Stromuhr, or rheometer, for measuring blood-pressure, 104
 Strychnia, action of, 472, 474
 SUBBORN, fat of man and the dog, 342; the secretion of milk, 345
 Sublingual saliva, 187
 Submaxillary gland, secretion of saliva, 206, 207, 222; of dog (diagram) 207; of rabbit, 222
 Submaxillary saliva, 187, 188
 Succinic acid, 607
 Succus entericus, 183, 204, 217
 Sugar, conversion of starch into, by the saliva, 184, 186; action of gastric juice on, 189; digestion of, 238; in small intestine, 240
 Sugar in urine, 323, 337; in the hepatic blood, 331; in the blood and urine, 250, 334, 339
 Sugar, milk-sugar, 344
 Sugar as food, 363, 365
 Sulphur as an element of food, 366
 Suppression of urine, 327, 350
 SUSLOWA, lymph-hearts of the frog, 479
 Swallowing, 231, 239
 Sweat (*See Perspiration*)
 Sympathetic action, 164
 Syntonin, 33, 201
 Systole of heart, duration of, 119

 Tactile judgments, 466
 Tactile perceptions, 463, 466
 Tactile sensations, 464, 483, 522
 Tambour, Marey's, for measuring blood-pressure (diagram), 117, 258
 TARCHANOFF, on the spleen, 347
 Tartar emetic, effects of, 237
 Taste, 460
 Taurin, 619

 Taurocholic acid, 624
 Tears, 448
 Teeth, action in mastication, 225
 Temperature, its influence on muscular irritability, 75; on ciliary action, 84; on the saliva, 185; on the gastric juice, 192
 Temperature of man and other animals, 372, 377
 Temperature, its effect on animals, 376
 Temperature, sensations of, 464
 Temperature (*See Cold, Heat*)
 Tension of the gases of blood and pulmonary air, 282, 285, 286, 287
 Terminal organs of the skin, 463
 Tests for proteids, 573
 Tetanus, 44, 45, 57, 66, 68, 77; sound in, 128
 Tetanus, Ritter's, 66
 Thermogenic nerves, 377, 379
 THIRY, on succus entericus, 204
 Thoracic duct, 245
 Thoracic respiratory movements, 256; effect of on circulation, 296
 THUDICHUM, on pigments in urine, 318
 Thymus, 561
 TIEDEMANN, researches on digestion, 252
 Time required for reflex actions, 478
 Tissues, fundamental, 4
 Tissues, contractile, 32—84
 Tissues, embryonic, 549
 Tissues, metabolic, 330
 Tissues, nervous, properties of, 85—95
 Tissues of chemical action, and their mechanisms, 183—252; digestion, 183—252; respiration, 253—310
 Tissues of reproduction, 541
 Tissues, respiratory, changes in the, 281
 Tissues, the death of, 568
 'Tone' of arteries, 156, 158, 159, 166, 168
 Tongue, its action in mastication and deglutition, 225, 226, 227
 Tonicity of skeletal muscles, 480
 Torricellian vacuum for extracting gas from blood, 268
 Touch, 462
 Tracings of respiratory movements, 256; blood-pressure curves and intra-thoracic pressure, 298 (*See Diagrams*)
 Transfusion of blood, 28
 Traube's curves, of blood-pressure in respiration, 300, 301, 304
 Tricuspid valves of the heart, 123, 125
 Trophic nerves, 381, 391
 Trypsin, 202, 204
 TSCHESCHICHIN, bodily heat, 378
Tubuli uriniferi, 317
 Turtle's heart-beat, 142
 Tyrosin, 200, 202, 242, 621

 Undulations of blood-pressure in respiration, 300
 Unstriated muscular tissue, 82
 Uremic poisoning, 350
 Urari poison, its effects on contractile tissues, 35, 67; its effect on heart-beat, 145, 146; its effect on cerebral functions,

- 163, 165; on chorda tympani, 214; on vomiting, 236; on respiration, 299; in producing diabetes, 338, 376
- Urea, 531; presence in perspiration, 311, 313; effect on secretion of urine, 321; secretion of, 326; and its allies, the history of, 348—355; relation to muscular exercise, 369
- Ureter, peristaltic contraction of the, 90, 93; in micturition, 327
- Urethra, 327
- Uric acid, 534; source of, 353; in the spleen, 348
- Urine, composition of, 317, 319; secretion of, 320; act of micturition, 327; kreatin in, 348; hippuric acid in, 354; average loss by, 359
- Urine of infancy, 558
- Urine, sugar in, 250
- Uriniferous tubules, 321
- Urobilin in urine, 319
- Urochrome, 318
- Uroerythrin in urine, 319
- 'Uterine milk,' 548
- Uterus, in menstruation, 542; in parturition, 553, 554
- Vagus, cardio-inhibitory action of, its effect, 144; relation to movements of stomach, 231; to vomiting 236; respiratory function of the, 290
- Vagus and the secretion of urine, 323
- Valerianic acid, 601
- Valves of the heart, 122—126
- Varnishing of animals, its effects, 314, 330
- Vascular mechanism, 6, 96—179; physical phenomena of the circulation, 96—140; the heart, 113—131; the pulse, 131—140; vital phenomena of the circulation, 140—179; changes in the heart-beat, 141; in the calibre of the minute arteries, vaso-motor actions, 154; changes in the capillary districts, 171; in the quantity of blood, 174
- Vaso-motor actions, 154
- Vaso-motor action, relation to secreting activity, 211
- Vaso-motor centre, 157, 158; relation to afferent nerves, 162, 164; relation to respiratory centre, 299; relation to renal secretion, 322
- Vaso-motor mechanisms, local, 165
- Veins, 97, 106, 107, 109; effect of respiratory movements on the, 298
- Velocity of the flow of blood, 103, 106, 111, 115; of the pulse-wave, 133; of sensory impulses, 393
- Venous blood, 267, 276, 280, 282, 283, 287, 293
- Venous pulse, 131
- Ventricle of the heart, 110, 112
- Vertigo, 495, 518
- VIERORDT, circulation of blood in retina, 98; hæmatometer for measuring blood-pressure, 105
- Villi, action of the, in absorption, 247
- Vision, region of distinct, 429; the reaction period, 522 (*See Sight*)
- Visual judgments, 444
- Visual perceptions, 427
- Visual purple, 414
- Visual sensations, 413
- 'Vital capacity' of the lungs, 255
- Vital phenomena of the circulation, 140—179
- Vitellin, 582
- Vocal cords, 225, 465
- Voice, the, 527, 532, 534
- VOIT, changes of air in respiration, 266; effects of starvation, 356; nutrition, 360, 363, 365, 369, 386; sleep, 565
- VOLKMANN, researches on blood-circulation, 103, 106, 179; lymph-hearts, 479
- Vomiting, 235
- Vowel-sounds, 532
- VULPIAN, vaso-motor action, 169; on union of motor and sensory nerves, 393; on conduction of impulses in the spinal cord, 483
- WALDEYER, lymph-hearts, 479
- Walking, 537
- WALLER, A., vascular mechanism, 179
- WASMANN, researches on digestion, 252
- WEBER, pulse-waves, 134; muscular contraction, 81; on visual sensations, 419; on tactile perceptions, 466, 470
- Weight of the body; phases of life, 556
- WEISKE and WILDT, on nutrition, 364
- Wharton's duct, 210
- Whispering, 536
- White corpuscles, 14, 28
- WILLIAMS on menstruation, 543
- WINOGRADOFF, diabetes, 339
- Winking, 447
- WISLICIENUS, on urea and muscular exercise, 369
- WITTICH, diabetes and digestion, 252, 295, 349
- WOLFFER, secretion of tears, 448
- WOLFFBERG, researches on respiration, 283
- WOROSCHILOFF on reflex actions, 477, 485
- WUNDT, spinal ganglia, 392
- Xanthin, 348, 355, 617
- Yawning, 309
- Yellow spot, 419, 425
- YOUNG-HELMHOLTZ, theory of colour sensations, 424
- ZALESKY on renal secretion, 350
- ZUNTZ, effect of cold on rabbits, 376; urari poisoning, 376
- Zymogen, 219

