

This is a reproduction of a library book that was digitized by Google as part of an ongoing effort to preserve the information in books and make it universally accessible.

Google™ books

<https://books.google.com>

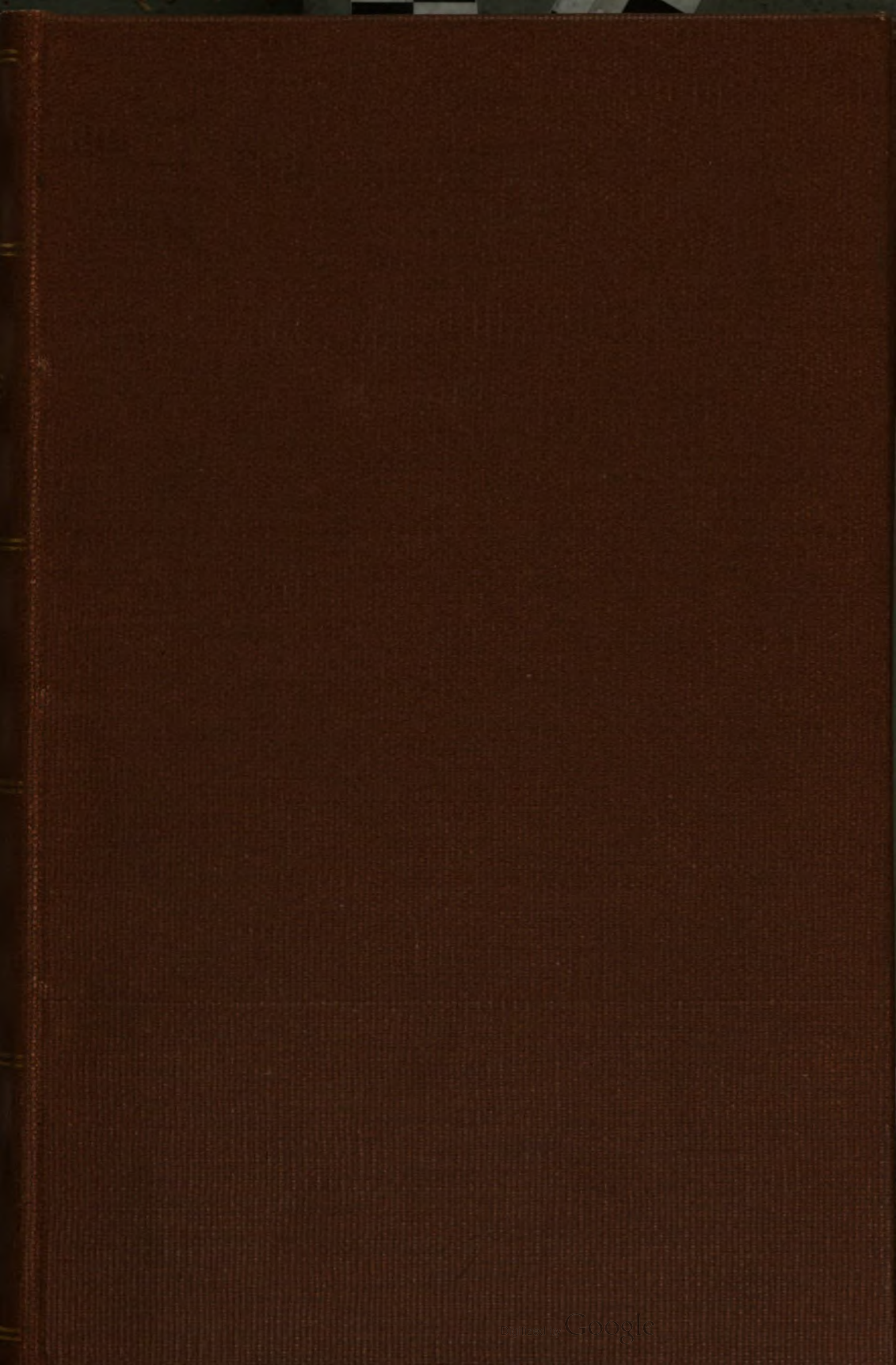



HARVARD UNIVERSITY



LIBRARY
OF THE
PEABODY MUSEUM OF AMERICAN
ARCHAEOLOGY AND ETHNOLOGY

GIFT OF
the Society

Received **May 1, 1878**

PROCEEDINGS
OF THE
LITERARY AND PHILOSOPHICAL SOCIETY
OF
LIVERPOOL,
DURING THE
SIXTY-SIXTH SESSION, 1876-77.
No. XXXI.

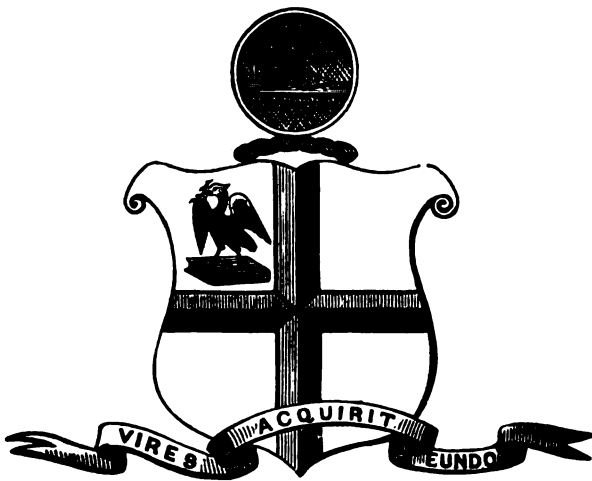

LONDON:
LONGMANS, GREEN, READER, & DYER.
LIVERPOOL:
D. MARPLES & CO., LIMITED, LORD STREET.
—
1877.

L. Soc. 48. 84
Gift of the Society
May 1, 1878

This Volume has been edited by the Honorary Secretary.

The Authors have revised their Papers.

The Authors alone are responsible for facts and opinions.

The Society exchanges Proceedings with other publishing bodies, through the Librarian, from whom back numbers may be obtained.

CONTENTS.

	PAGE
COUNCIL	vii
LIST OF MEMBERS	viii
HONORARY MEMBERS	xx
CORRESPONDING MEMBERS.....	xxii
ASSOCIATES.....	xxiii
ADDITIONS TO THE LIBRARY	xxiv
LIST OF SOCIETIES, ETC., TO WHICH THIS VOLUME IS PRESENTED	xl
BALANCE SHEET	xlv
ANNUAL MEETING—REPORT	xlvii
ELECTION OF COUNCIL.	
RE-ELECTION OF ASSOCIATES.	
PRESIDENT'S INAUGURAL ADDRESS ON THE PRESENT STATE OF LINGUISTIC SCIENCE.	
FIRST ORDINARY MEETING	li
Conversazione on Natural Science.	
Argo Collection.	
On the Sponges of the "Argo" Expedition, by Mr. THOS. HIGGIN.	
On lower Cryptogamic Plants, etc., of the "Argo" Expedition, by the Rev. H. H. HIGGINS, M.A.	
On the subject of the Passage of Plants across the Atlantic, by the Rev. H. H. HIGGINS, M.A.	
Summary of the Fishes of the "Argo" Expedition, by Mr. THOMAS J. MOORE.	

	PAGE
SECOND ORDINARY MEETING	lxii
Discussion on Discovery of Fossil Corals and Coal at Disco Island.	
Major-General Bellasis' Collection of Arms, &c., from Mooltan.	
Specimen of Manganese, exhibited by Dr. WHITTLE.	
Specimen of Gallium, exhibited by Mr. STEARN.	
REV. T. P. KIRKMAN, M.A., F.R.S., on "How we Come to Know."	
THIRD ORDINARY MEETING	lxii
Specimens of Isopod Crustaceans from Jamaica, collected by Capt. PERRY, exhibited by Mr. T. J. MOORE.	
Mr A. J. MOTT, on "Haeckel's History of Creation."	
FOURTH ORDINARY MEETING	lxiii
Photographs of Title Pages of two of the earliest Books printed in Liverpool, exhibited by Mr. J. A. PICKTON, F.S.A.	
Extract of a letter from Berlin, describing the Young Gorilla, read by Mr. ALFRED HIGGINSON.	
EXTRAORDINARY MEETING	lxiv
Proposed Alteration of Laws.	
FIFTH ORDINARY MEETING	lxiv
<i>Britain's Remembrancer</i> , exhibited by Mr. J. A. PICKTON, F.S.A.	
Browning's Akribetic Galvanometer on Ridout's Patent, exhibited by Mr. LEWIS HUGHES.	
Cape Diamond, exhibited by Mr. T. J. MOORE.	
Sprengel Vacuum Pumps of improved form, exhibited by Mr. C. H. STEARN.	
Mr. JOSIAH MARPLES, on "Type Founders and Type Founding."	

	PAGE
EXTRAORDINARY MEETING	lxvi
Proposed Alteration of Laws.	
SIXTH ORDINARY MEETING	lxvi
Autotype Reproduction of John Milton's "Common Place Book," exhibited by Mr. JOHN MILLER.	
Mr. J. LINTON PALMER, on "The Marquesans—their History, Traditions, and Customs."	
EXTRAORDINARY MEETING	lxvi
Proposed Alteration of Laws.	
SEVENTH ORDINARY MEETING	lxvii
Discussion on Mr. MOTT's Paper on "Haeckel's History of Creation."	
EIGHTH ORDINARY MEETING	lxvii
Patent Electric Pen, exhibited by Mr. CHANTRELL.	
Mr. JOSEPH BOULT, F.R.I.B.A., on "The Suffix -ster."	
NINTH ORDINARY MEETING	lxviii
Extracts from a letter from Mr. John Adams, of Pitcairns Island, relative to the Sea Serpent, read by Mr. J. LINTON PALMER, R.N.	
Mr. EDWARD DAVIES, F.C.S., on "Popular Errors about Poisons."	
TENTH ORDINARY MEETING	lxx
Double Oscillating Pendulums for recording Lissajous' Curves, exhibited by Mr. JOSEPH MARPLES.	
Rev. T. P. KIRKMAN, M.A., F.R.S., on "The First Definition of the Scholastic Philosophy."	
ELEVENTH ORDINARY MEETING	lxx
Selection from a Collection of Specimens made by Capt. CAWNE WARREN; exhibited by Mr. T. J. MOORE, and described by Capt. WARREN.	
Classification of the <i>Algæ</i> , <i>Zoophytes</i> , and <i>Polyzoa</i> , by Miss GATTY.	

	PAGE
Specimens collected by Capt. SLACK, exhibited by Mr. T. J. MOORE.	
List of Algæ and Polyzoa in the collection, by Miss GATTY.	
Marine Organisms, collected by Capt. J. H. MORTIMER, exhibited by Mr. T. J. MOORE.	
Notes on <i>Physalia</i> , by Capt. MORTIMER, with remarks by Mr. W. J. SOLLAS, F.G.S., &c.	
Mr. G. H. MORTON, F.G.S., on "The Introduction of Geological Maps."	
Dr. NEVINS, on "The Translation of <i>Συνίημι</i> and its forms, and of <i>Ἴνα μὴ</i> with a subjunctive mood, in the Authorised Version of the New Testament."	
TWELFTH ORDINARY MEETING.....	lxxviii
Roll of Liverpool Volunteers in 1797, exhibited by J. A. PICTON, F.S.A.	
Discourse delivered by Wm. Roscoe, on the opening of the Royal Institution, 25th Nov., 1817. Presented by Mr. ALFRED HIGGINSON.	
Mr. ALFRED MORGAN, on the "Origin and Progress of the United States Geological and Geographical Survey of the Territories."	
Mr. MALCOLM GUTHRIE, on "The Causational Theory of Volition—a Reply to Strictures in Dr. Carpenter's Mental Physiology."	
THIRTEENTH ORDINARY MEETING.....	lxxix
Rev. H. H. HIGGINS, M.A., "Liverpool Museum Report, No. 1, devoted to the Mollusca of the Argo Expedition to the West Indies."	
Mr. E. R. RUSSELL, on "The Autobiography and Memorials of Miss Martineau."	

	PAGE
FOURTEENTH ORDINARY MEETING	lxxix
Notes on Lepidopterous Cocoons and Larva Cases from São Paulo, Brazil, by Mr. E. DUKINFELD JONES (with a plate).	
Mr. ALFRED MORGAN, on "The Cliff Houses and Antiquities of Colorado and New Mexico" (with a map and two plates).	
Mr. J. C. REDISH, on "The Silver Question."	

PAPERS PRINTED.

	PAGE
—Mr. J. A. PICTON, F.S.A.—President's Address—"On the Present State of Linguistic Science"	1
Rev. T. P. KIRKMAN, M.A., F.R.S.—"How we Come to Know"	303
Mr. A. J. MOTT.—On "Haeckel's History of Creation" ...	41
Dr. NEVINS.—"On some Phases of Modern French Thought"	123
Mr. JOSIAH MARPLES.—"On Type Founders and Type Founding" (with illustrations)	147
DISCUSSION of Mr. Mott's Paper "On Haeckel's History of Creation"	91
Mr. JOSEPH BOULT, F.R.I.B.A.—"On the Suffix -ster"	245
Mr. EDWARD DAVIES, F.C.S.—"Popular Errors about Poisons"	317
Rev. T. P. KIRKMAN, M.A., F.R.S.—"The First Definition of the Scholastic Philosophy"	229
— J. LINTON PALMER, Marquessian tradition of the Deluge. 271 Mr. G. H. MORTON, F.G.S.—"The Introduction of Geological Maps"	298
Dr. NEVINS.—"On the Translation of <i>Συνίημι</i> and its forms, and of <i>ἴνα μὴ</i> with a subjunctive mood, in the Authorised Version of the New Testament"	167

	PAGE
Mr. ALFRED MORGAN.—“Origin and Progress of the United States Geological and Geographical Survey of the Territories”	357
Rev. H. H. HIGGINS, M.A.—“Liverpool Museum Report, No. 1” (with a coloured plate).....	405
Mr. E. R. RUSSELL.—“The Autobiography and Memorials of Miss Martineau”	185
— Mr. ALFRED MORGAN.—“The Cliff Houses and Antiquities of Colorado and New Mexico” (with three plates)	348
Mr. J. C. REDISH.—“The Silver Question”	367

SESSION LXVI., 1876-77.

President.

JAMES ALLANSON PICTON, F.S.A.

Ex-Presidents.

REV. J. MARTINEAU, D.D., LL.D.	REV. C. D. GINSBURG, LL.D.
REV. J. BOOTH, LL.D., F.R.S.	JOHN BIRKBECK NEVINS, M.D.
REV. H. H. HIGGINS, M.A.	ALBERT JULIUS MOTT.
WILLIAM IHNE, Ph.D.	

Vice-Presidents.

ALFRED HIGGINSON, M.R.C.S.
 THOS. J. MOORE, COR. MEM. Z.S.L.
 JOHN J. DRYSDALE, M.D., M.R.C.S.

Honorary Treasurer.

RICHARD C. JOHNSON, F.R.A.S.

Honorary Secretary.

JAMES BIRCHALL.

Honorary Librarian.

ALFRED MORGAN.

Council.

J. CAMPBELL BROWN, D.Sc., &c.	GEORGE H. MORTON, F.G.S.
ALFRED E. FLETCHER, F.C.S.	BARON LOUIS BENAS.
W. CARTER, M.B.	THOMAS HIGGIN, F.L.S.
REV. E. M. GELDART, M.A.	J. L. PALMER, F.S.A., F.R.G.S.
EDWARD R. RUSSELL.	JOSIAH MARPLES.
EDWARD DAVIES, F.C.S.	JOHN W. HAYWARD, M.D.
C. H. STEARN.	SIBLEY HICKS, F.R.C.S.

ORDINARY MEMBERS,

ON THE SOCIETY'S ROLL AT THE CLOSE OF THE 66TH SESSION,

CORRECTED TO JUNE, 1877.

Life Members are marked with an Asterisk.

- Oct. 21, 1872 Abbott, Joseph, B.A., 2, *Picton Street, Wavertree-road, and Liverpool College, Shaw-street, Everton.*
- Oct. 11, 1833 Aikin, James, 4, *Gambier-terrace.*
- Nov. 4, 1867 Allen, John Fenwick, *Peaseley Vale, St. Helens.*
- March 7, 1864 Archer, F., B.A. Trin. Col. Cantab., *Boundary Cottage, Little Crosby.*
- *Nov. 28, 1853 Archer, T. C., F.R.S.E., F.R.S.S.A., Director of the Industrial Museum, *Edinburgh.*
- Dec. 14, 1863 Ashe, Theop. Fielding, 9-15, *Atherton-street.*
- Feb. 22, 1855 Avison, Thomas, F.S.A., 18, *Cook-street, and Fullwood Park, Aigburth.*
- Jan. 11, 1864 Bagshaw, John, 87, *Church-street, and 26, Bentley-road, Prince's Park.*
- May 4, 1863 Bailey, Fras. J., L.R.C.P., 51, *Grove-street.*
- Nov. 13, 1876 Ball, Geo. Hy., *The Priory, St. George's Mount, New Brighton.*
- April 20, 1874 Barton, Rev. John, M.A., *Vicarage, Rainhill.*
- Nov. 15, 1869 Beer, Joseph B. de, *Northern Assurance Chambers, Tithebarn-street.*
- March 9, 1857 Bell, Christopher, *Redcross-street, and 55, Hamilton-square, Birkenhead.*

- Jan. 11, 1875 Bell, Wilson, 1, *Laburnum Villas, Egerton-street, New Brighton.*
- Feb. 22, 1875 Bellew, Thomas A., *Cunard Mail Office, 8, Water-street.*
- Nov. 15, 1875 Bellis, William, *Sunny Bank, Victoria Park, Wavertree.*
- Dec. 10, 1866 Benas, Baron Louis, 5, *South Castle-street.*
- Nov. 27, 1865 Biggs, Arthur Worthington, 28, *Exchange Street East*, and 11, *Percy-street.*
- Feb. 6, 1872 Biggs, John H. W., 6, *Windsor-buildings, George-street.*
- Oct. 31, 1859 Birch, Jas. (Messrs. Reiss Bros.), 12, *The Temple.*
- Jan. 25, 1864 Birchall, James, Governor of the Liverpool Industrial Schools, *Kirkdale*, HON. SECRETARY.
- Dec. 14, 1874 Black, Rev. R., M.A., 26, *Falkner-street.*
- March 9, 1866 Blood, William, *Chamber of Commerce*, and *Greta Mount, 5, Woodchurch-road, Birkenhead.*
- Nov. 26, 1866 Boulton, Joseph, 15D, *Exchange-buildings, W.*
- Oct. 19, 1868 Bower, Anthony, *Vauhall Foundry*, and *Bowersdale, Seaforth.*
- Oct. 21, 1872 Bowring, C. T., *Elmsleigh, Prince's Park*, and 20, *Lancaster-buildings, Tithebarn-street.*
- Dec. 15, 1873 Brass, Joseph, M.D., 6, *Upper Parliament-street.*
- Nov. 4, 1867 Bramwell, Ed., *Cowley Hill, St. Helens.*
- Jan. 27, 1873 Bremner, H. H., 15, *Lord-street.*
- Nov. 12, 1866 Browne, Edgar A., 86, *Bedford-street South.*
- Oct. 18, 1869 Brown, Dr. J. Campbell, D.Sc., F.C.S., *School of Medicine, Dover-street.*
- Oct. 30, 1876 Bulman, Richard (Messrs. Baker, Bulman & Co.), 2, *India-buildings, Water-street.*
- Feb. 4, 1867 Burden, Edward, 123, *Upper Parliament-street.*
- Nov. 12, 1866 Butler, Rev. George, *The College, Shaw-street.*
- April 18, 1864 Burne, Joseph, *Royal Insurance Office, 1, North John-street* and *Higher Tranmere.*
- *May 1, 1848 Byerley, Isaac, F.L.S., F.R.C.S., *Victoria-road, Seacombe.*

- Nov. 8, 1862 Cameron, John, M.D., M.R.C.P., Physician to the Southern Hospital, and Lecturer on Medicine at the Royal Infirmary School of Medicine, 17, *Rodney-street*.
- Dec. 2, 1872 Carey, Eustace, *Appleton-in-Widnes, near Warrington*.
- Jan. 9, 1865 Cariss, Astrup, 40, *Castle-street*.
- Nov. 18, 1876 Carson, Thomas, M.D., 822, *Upper Parliament-street*.
- Mar. 4, 1872 Carter, W., M.B.Lond., 74, *Rodney-street*.
- Dec. 2, 1861 Chadburn, William, 71, *Lord-street*.
- April 8, 1876 Chantrell, G. F., 1, *St. James's Mount*.
- Feb. 22, 1875 Chapman, Thomas, *Oaklynn, Parkfield-road, Prince's Park*.
- Oct. 18, 1869 Cook, Henry James, *Byrom-street, and Burbo House, Blundell Sands*.
- Dec. 18, 1875 Cowell, Peter, *Free Library, William Brown-street*.
- Oct. 6, 1868 Crosfield, William, Jun., 28, *Temple Court, and Alexandra-drive, Ullet-road*.
- Dec. 14, 1868 Daly, Dennis, 11, *Rumford street*.
- Nov. 12, 1866 Davies, E., F.C.S., *The Laboratory, Royal Institution, Colquitt-street*.
- Nov. 2, 1863 Dawbarn, William, *The Temple, Dale-street, and Mossley-hill*.
- Oct. 20, 1873 Day, George, 23, *Brunswick-street, and Abbey Cottage, Aintree*.
- Oct. 1, 1866 Dawson, Thomas, 26, *Rodney-street*.
- April 6, 1874 Dodd, John, 6, *Thomas-street, and 2, Derby-terrace, Rock Ferry*.
- Nov. 27, 1863 Dove, John M., *Claughton*.
- Nov. 1, 1875 Doyle, Jas. F., 4, *Harrington-street, and Merton-road, Bootle*.
- Jan. 23, 1848 Drysdale, John James, M.D.Edin., M.R.C.S. Edin., 36, *Rodney-street*.
- Feb. 4, 1856 Duckworth, Henry, F.L.S., F.R.G.S., F.G.S., 82, *Brown's-buildings, Exchange-street, W.*

- Nov. 1, 1875 Edmunds, William, *Edmond-street Chambers, Edmond-street.*
- *Nov. 27, 1848 Edwards, J. B., Ph.D. Gies, F.C.S., Professor Medical Faculty of Bishop's College, *Montreal.*
- Mar. 21, 1870 Edwards, Edward E. (Smith, Edwards & Co.), *Adelaide-buildings, 4, Chapel-street.*
- Feb. 24, 1868 Elliot, John, 35, *Peter's-lane.*
- April 7, 1862 English, Charles J., 26, *Chapel-street, and 26, Falkner-square.*
- April 20, 1874 English, Robert A., 26, *Falkner-square.*
- *Dec. 18, 1852 Ferguson, William, F.L.S., F.G.S., *Kimmundy House, near Mintlaw, N.B.*
- Oct. 1, 1866 Fletcher, Alfred E., F.C.S., H.M. Inspector of Alkali Works for the Western District, 5, *Edge-lane.*
- Nov. 15, 1875 Fleming, E. L., F.C.S., *Borax Works, Old Swan.*
- *Mar. 19, 1855 Foard, James Thomas, 5, *Essex-ct., Temple, F.C.*
- Dec. 2, 1872 Forwood, Wm. Bower (Messrs. Leech, Harrison and Forwood), 16, *Queen-buildings, 11, Dale-street, and Burbo Bank-road, Blundell Sands.*
- Nov. 16, 1874 Fothergill, Charles George, *Gambier-terrace.*
- Jan. 12, 1874 Frost, John Pownall, 10, *North John-street.*
- Feb. 19, 1877 Gardner, Rev. Henry, *The Hamlet, Belvidere-road.*
- Nov. 29, 1875 Gardner, William, *Ash Lea, Oak-hill Park.*
- *Feb. 6, 1854 Gee, Robert, M.D. Heidelb., M.R.C.P., Lecturer on Diseases of Children, Royal Infirmary School of Medicine; Physician Workhouse Hospital, 5, *Abercromby-square.*
- Nov. 8, 1878 Geldart, Rev. E. M., M.A.
- Nov. 14, 1853 Greenwood, Henry, 32, *Castle-street, and Stanley Park.*
- Nov. 16, 1874 Grindley, Benjamin H., *Albion Office, Sir Thomas' Buildings.*
- Dec. 14, 1874 Gunn, Rev. W. E. B., M.A., 3, *Blackburne-terrace, Blackburne-place.*

- Nov. 16, 1874 Guthrie, Malcolm, 31, *Stanley-road, Bootle.*
- Jan. 22, 1855 Hakes, James, M.R.C.S., Surgeon to the Northern Hospital, 30, *Hope-street.*
- Oct. 18, 1875 Hale, Philip A., Bank of England, *Castle-street.*
- Oct. 21, 1872 Halliwell, Joseph, 10, *College-lane.*
- *Jan. 21, 1856 Hardman, Lawrence, 35, *Rock Park, Rock Ferry.*
- Dec. 13, 1875 Harpin, E., 46, *Onslow-road, Elm Park, Fairfield.*
- Nov. 15, 1869 Hartwig, Estevan H. L., 62, *Palmaille, Antona, Hamburg.*
- Nov. 30, 1874 Harvey, Henry, M.B., *High-street, Wavertree.*
- Feb. 6, 1865 Hassan, Rev. E., *Alma-terrace, Sandown-lane.*
- Nov. 13, 1865 Hayward, John Williams, M.D., 117, *Grove-street.*
- Feb. 6, 1865 Hebson, Douglas, 13, *Tower Chambers,* and 58, *Bedford-street South.*
- Nov. 4, 1872 Hicks, Sibley, F.R.C.S., 2, *Erskine-street.*
- Dec. 28, 1846 Higgins, Rev. H. H., M.A. Cantab, F.C.P.S., *Liainhill, EX-PRESIDENT.*
- *Oct. 31, 1836 Higginson, Alfred, M.R.C.S., 135, *Tulse Hill, London.*
- March 22, 1869 Higgin, Thomas, F.L.S., 33, *Tower-buildings,* and *Huyton.*
- Nov. 16, 1863 Holden, Adam, 48, *Church-street,* and 2, *Carlton-terrace, Milton-road.*
- March 9, 1868 Holme, James, 10, *Huskisson-street,* and *Eldon Chambers, South John-street.*
- Nov. 30, 1874 Holme, Rev. Arthur P., *Tattenhall, near Chester.*
- *Dec. 14, 1862 Holt, Robert Durning, 6, *India-buildings,* and 29, *Edge-lane.*
- April 9, 1877 Hooper, Richard Bennett, 6, *Loudon Grove, North Hill-street.*
- Jan. 24, 1876 Hughes, Lewis, 38, *St. Domingo Vale, Everton.*
- *Nov. 13, 1854 Hunter, John, Member Historic Society, Pennsylvania, *Halifax, Nova Scotia.*
- Dec. 13, 1875 Hutchinson, Joseph B., M.R.C.S., 77, *Upper Parliament-street.*

- Jan. 26, 1857 Hutton, David, 3, *St. George's-crescent*, and 61, *Canning-street*.
- *April 29, 1850 Ihne, William, Ph.D., Bonn, *Villa Felseck, Heidelberg*, EX-PRESIDENT.
- Feb. 23, 1857 Imlach, Henry, M.D.Edin., 1, *Abercromby-square*.
- Oct. 19, 1874 Imlach, Francis, M.B., 1, *Abercromby-square*.
- Oct. 20, 1873 Johnson, Digby, Royal Insurance Office, *North John-street*.
- March 10, 1862 Johnson, Richard, *Queen-buildings*, and *Higher Bebington Hall, Bebington*.
- Jan. 26, 1863 Johnson, Richard C., F.R.A.S., *Queen-buildings Dale-street*, and *Higher Bebington*, HON. TREASURER.
- Oct. 30, 1876 Johnson, James Henry, F.G.S., 64, *Albert-road, Southport*.
- Mar. 19, 1877 Johnson, [Rev. H. I., M.A., *Royal Institution School*, and *Penrhyn House, Ullet-road*.
- Feb. 24, 1868 Jones, Charles W., 3, *Childwall-road, Waver-tree*.
- *April 4, 1852 Jones, Morris Charles, F.S.A., F.S.A.Scot., 20, *Abercromby-square*.
- Oct. 18, 1869 Jones, William Bolton, 21, *South Castle-street*.
- Nov. 30, 1874 Joseph, Rev. Morris, 67, *Canning-street*.
- Oct. 2, 1865 Kendal, Robinson, 16, *Water-street*, and 178, *Bedford-street*.
- Nov. 15, 1869 King, Jos., 13, *Exchange-alley W.*, and *Treleearan House, Blundell Sands*.
- Nov. 1, 1869 Kinsman, W. N., 8, *Derwent-road, Stoneycroft*.
- *Jan. 14, 1839 Lassell, William, F.R.SS. L. and E., F.R.A.S., 27, *Milton-street*, and *Wapping*.
- Oct. 21, 1844 Lear, John, *Stoneby Cottage, Stoneby Green, New Brighton*.
- Nov. 3, 1873 Lee, Hamilton (Messrs. Lee & Nightingale), *North John-street*.
- Nov. 3, 1873 Lee, Harold (Messrs. Lee & Nightingale), *North John-street*.

- Dec. 11, 1871 Leigh, Richmond, M.R.C.S.E., 141, *Park-road*.
- Nov. 1, 1875 Lutschaunig, Alfred, *Cable-street*.
- April 17, 1865 MacCheane, Wm., M.R.C.S., 47, *Shaw-street*.
- Oct. 30, 1876 McGrath, —, M.D., 12, *Alfred-street, Great George-street*.
- April 20, 1868 Marples, David, *Lord street and Cable-street, and 5, Mount Grove, Oxton, Birkenhead*.
- Nov. 14, 1870 Marples, Joseph, 23, *Leece-street, and Carlton-road, Tranmere*.
- Nov. 17, 1873 Marples, Josiah, *Melvill Chambers, Lord-street, and Broomfield, Egremont*.
- Feb. 19, 1877 Marples, William, 9, *North John-street*.
- Feb. 9, 1874 Marsden, Peter Crook, *Lymefield, Heaton, near Bolton*.
- Feb. 24, 1868 Marsh, John, *Ran Lee, Rainhill*.
- Jan. 21, 1839 Martin, Studley, 27, *Brown's-buildings, and 177, Bedford-street South*.
- Feb. 20, 1871 Mason, Alfred H., F.C.S., Lond. & Berlin, 56, *Hanover-street*.
- Nov. 2, 1874 Matheson, Rev. A. Scott, *Dunneyat, Stanley-road, Bootle*.
- Feb. 5, 1844 Mayer, Joseph, F.S.A., F.R.A.S., F.E.S. *Pennant House, Lower Bebington*.
- Nov. 17, 1873 Mellor, James, Jun., *Sefton House, Great Crosby*.
- Dec. 14, 1874 Mellor, John, 2, *Church-road, Walton*.
- Oct. 31, 1859 Moore, Thomas John, Corr. Mem. Z.S.L., Curator Free Public Museum, *William Brown-street, VICE-PRESIDENT*.
- Nov. 15, 1869 Morgan, Alfred, 126, *London-road, and 2, Rathbone-terrace, Wellington-road, Wavertree, Hon. LIBRARIAN*.
- Jan. 8, 1855 Morton, George Highfield, F.G.S., 122, *London-road*.
- April 16, 1849 Moss, Rev. John James, B.A., *Upton, Cheshire*.
- Oct. 29, 1850 Mott, Albert Julius, 82, *Church-street, and Adsett-court, Westbury-on-Severn, EX-PRESIDENT*.

- April 8, 1854 Mott, Charles Grey, 27, *Argyle-street, Birkenhead, and Cavendish-road, Birkenhead Park.*
- Mar. 28, 1874 McCulloch, D. B., 23, *Queen-buildings, Dale-street.*
- *Oct. 21, 1867 Muspratt, E. K., *Seaforth Hall, Seaforth.*
- Oct. 20, 1865 Nevins, John Birkbeck, M.D.Lond., M.R.C.S., Lecturer on Materia Medica, Royal Infirmary School of Medicine, 8, *Abercromby-square, Ex-PRESIDENT.*
- Feb. 6, 1865 Newton, John, M.R.C.S., 20, *Marmaduke-street, Edge-hill.*
- Oct. 30, 1876 Nickson, John Horatio, 147, *Grove-street.*
- Nov. 2, 1868 Norrie, Rev. B. A. W., M.A. Cantab., *The College School, Huyton.*
- *Oct. 15, 1855 North, Alfred, 23, *Landsdown-Crescent, Notting-hill, London, W.*
- Jan. 8, 1877 Ogston, James, *Maresfield, Wavertree.*
- Dec. 18, 1866 Owen, Peter (Farnworth & Jardine), *Liverpool and London-Chambers.*
- Feb. 21, 1870 Packer, James Macnamara, M.D., *Rose Cottage, Poplar Bank, Huyton.*
- Nov. 2, 1874 Palmer, John Linton, F.S.A., F.R.G.S., Fleet Surgeon R.N., 24, *Rock Park, Rock Ferry.*
- Dec. 15, 1873 Parnell, E. W., 19, *Deane-road, Edge-lane.*
- Nov. 16, 1874 Parratt, John, *Waterloo.*
- Mar. 8, 1869 Parratt, Thomas P., *Silverton, North Crosby-road, Waterloo.*
- Mar. 19, 1877 Parry, J. F., *Sandon-terrace.*
- Jan. 9, 1871 Patterson, John, 16, *Devonshire-road, Prince's Park.*
- Nov. 4, 1861 Philip, Thomas D., 48, *South Castle-street, and Holly-road, Fairfield.*
- Dec. 28, 1846 Picton, James Alanson, F.S.A., Chairman of the Library and Museum Committee, 11, *Dale-street, and Sandy Knowe, Wavertree, PRESIDENT.*

- Nov. 1, 1875 Picton, William Henry, *The Pines, Bromborough-road, Lower Bebington.*
- Nov. 16, 1874 Pim, Edward, 41, *Tithebarn-street.*
- April 30, 1866 Prag, Rev. Jacob, 99, *Upper Warwick-street.*
- Mar. 18, 1872 Pringle, Adam, *Grove Park.*
- Nov. 18, 1871 Proctor, Peter, M.R.C.S., and L.S.A.Lond., 18, *St. James-road.*
- Nov. 1, 1875 Prytherch, John, M.D., *Mitford-street, Netherfield-road North.*
- *Jan. 22, 1866 Raffles, William Winter, 54, *Brown's-buildings, and Sunnyside, Prince's Park.*
- Nov. 12, 1860 Rathbone, Philip H., *Liverpool and London Chambers (H), and Greenbank Cottage, Wavertree.*
- March 24, 1862 Rathbone, Richard Reynolds, 17, *Lancaster buildings, Tithebarn-street, and Beechwood House, Grassendale.*
- *Jan. 7, 1856 Rawlins, Charles Edward, 12, *Rumford-court, Rumford-place, and Rock Mount, Rainhill.*
- Jan. 9, 1870 Rawlins, Gerald W., *Brook Cottages, Rainhill.*
- Nov. 17, 1851 Redish, Joseph Carter, *Lyceum, Bold-street.*
- Jan. 10, 1876 Reid, Alexander, *Royal Insurance Office, North John-street.*
- Dec. 12, 1870 Rickard, Wm., LL.D., *Alverton House, 86, Upper Parliament-street.*
- Feb. 19, 1877 Rich, J. D., *General Post Office, and Ivy Lodge, Linnet-lane.*
- Jan. 11, 1875 Richardson, Joseph (Messrs. Laces & Co.), *Union-court, and 98, Bedford-street South.*
- Nov. 29, 1869 Roberts, Isaac, F.G.S., 26, *Rock Park, Rock Ferry.*
- Dec. 4, 1876 Roberts, Richard (Messrs. Roberts & Son), 18, *Hackin's-hey, and Mossley-hill.*
- Feb. 4, 1867 Robinson, Joseph F., 1, *Knowsley-buildings, Tithebarn-street.*
- Oct. 4, 1869 Rogers, J. Frederick, 7, *Victoria-street, and 22, Ullet-road, Prince's Park.*

- Jan. 10, 1876 Rogerson, George Russell, F.R.A.S., F.R.G.S.,
Union Court, and Allerton.
- April 18, 1854 Rowe, James, 16, *South Castle-street*, and 105,
Shaw-street.
- Jan. 22, 1872 Russell, Edward R., "*Daily Post*," *Lord-street.*
and 53, *Bedford-street.*
- *Feb. 20, 1865 Samuel, Albert H., *Cumberland-terrace, Upper*
Parliament-street.
- Feb. 19, 1877 Samuel, Douglas Ralph, 23, *Mount Pleasant,*
Waterloo.
- April 7, 1862 Samuel, Harry S., 11, *Orange-court*, and 2,
Canning-street.
- Nov. 30, 1874 Samuel, William Hy., 145, *Upper Parliament-*
street.
- Mar. 19, 1866 Sephton, Rev. John, M.A., *Liverpool Institute.*
- Nov 2, 1868 Sharp, Charles, *Liverpool Institute.*
- Nov. 16, 1868 Sheldon, E.M., M.R.C.S., 223, *Boundary-street.*
- Oct. 29, 1866 Shimmin, Hugh, 56, *Cable Street*, and *Tue Brook,*
West Derby.
- Oct. 18, 1875 Simpson, James, 10, *Runford-place.*
- Nov. 7, 1864 Skinner, Thomas, M.D.Edin., *Dunedin House,*
64, *Upper Parliament-street.*
- Dec. 10, 1866 Smith, Elisha (Henry Nash & Co.), 12, *Tower-*
buildings North.
- April 4, 1870 Smith, James, 9, *Lord-street*, and *Ribblesdale*
Villas, 22, Merton-road, Bootle.
- Feb. 23, 1863 Smith, J. Simm, Royal Insurance Office, *Blount*
House, Croydon.
- Feb. 24, 1862 Snape, Joseph, Lecturer on Dental Surgery,
Royal Infirmary School of Medicine, 75,
Rodney-street.
- April 20, 1874 Snow, Rev. T., M.A., 55, *Seel-street.*
- Jan. 24, 1876 Souttar, Robinson, Tramway Company, 8, *Castle-*
street, and 18, *Christchurch-road, Claughton-*
Birkenhead.
- Nov. 12, 1860 Spence, Charles, 4, *Old Hall-street.*

- Feb. 10, 1862 Spence, James, 18, *Brown's-buildings, Exchange,*
and 10, *Abercromby-square.*
- Nov. 27, 1865 Spola, Luigi, LL.D., 6a, *Hardman-street.*
- Jan. 18, 1868 Stearn, C. H., Bank of England, *Castle-street,* and
8, *Eldon-terrace, Rock Ferry.*
- Oct. 24, 1876 Stearn, Rev. William, D.D., 8, *Hope-place.*
- Nov. 18, 1876 Stephens, Thomas English, 11, *Victoria-street.*
- Nov. 1, 1875 Stevenson, John, *Prince Alfred-road, Wavertree.*
- Jan. 9, 1865 Stewart, Robert E., L.D.S., R.C.S., Dental Sur-
geon, Royal Southern Hospital, and Liverpool
Dental Hospital, 87, *Rodney-street.*
- Oct. 18, 1858 Stuart, Richard, 11, *Manchester-buildings,* and
Brooklyn Villa, Breeze Hill, Walton.
- *Feb. 19, 1865 Taylor, John Stopford, M.D.Aberd., F.R.G.S.,
2, *Millbank-terrace, Anfield-road.*
- Nov. 29, 1875 Tetley, John H., *Sunnyside, 21, Rock Park, Rock*
Ferry.
- Feb. 19, 1877 Thacker, Reginald P., *Mandeville, Aigburth-road.*
- Nov. 17, 1850 Tinling, Chas., *Victoria-street,* and 29, *Onslow-*
road, Elm Park.
- Dec. 4, 1876 Torpy, Rev. Lorenzo, M.A., *St. John's, Toxteth*
Park.
- *Feb. 19, 1844 Turnbull, James Muter, M.D.Edin., M.R.C.P.,
Physician Royal Infirmary, 86, *Rodney-street.*
- Oct. 21, 1861 Unwin, William Andrew, 11, *Rumford-place.*
- Oct. 21, 1844 Vose, James Richard White, M.D.Edin., F.R.C.P.
Physician Royal Infirmary, 5, *Gambier-terrace.*
- Dec. 2, 1872 Waite, Wm. Henry, D.D.S., L.D.S., 10, *Oxford-*
street.
- Mar. 18, 1872 Walker, George E., F.R.C.S., 48, *Rodney-street.*
- Mar. 18, 1861 Walker, Thomas Shadford, M.R.C.S., 82, *Rodney-*
street.
- Jan. 27, 1862 Walmsley, Gilbert G., 50, *Lord-street.*
- Jan. 9, 1865 Walthew, William, *Phoenix Chambers,* and *Vine*
Cottage, Aughton.
- Feb. 19, 1877 Wallace, John, M.D., 4, *Canning-street.*

- Mar. 4, 1872 Ward, Thomas, *Brookfields House, Northwich.*
- Dec. 13, 1869 Waterhouse, Harold, 37, *Catherine-street.*
- Dec. 2, 1861 Weightman, William Henry, *Minster-buildings, Church-street, and Cambridge-road, Seaforth.*
- Oct. 30, 1876 Weightman, Arthur (Messrs. Field & Weightman), *Talbot Chambers, 3, Fenwick-street, W.*
- April 7, 1862 Whittle, Ewing, M.D., Lecturer on Medical Jurisprudence, Royal Infirmary School of Medicine, 77A, *Upper Parliament-street.*
- Jan. 11, 1875 Williams, George A., *Lombard Chambers, Bixteth-street.*
- Nov. 1, 1875 Wilson, Ed. J., 14, *Durning-road.*
- Nov. 2, 1874 Wolf, Jas. O. de (Messrs. T. C. Jones & Co.), 26, *Chapel-street.*
- Mar. 18, 1861 Wood, George S. (Messrs. Abraham & Co.), 20, *Lord-street, and Bellevue-road, Wavertree.*
- Nov. 14, 1870 Wood, John J. (Messrs. Abraham & Co.), 20, *Lord-street.*
- Nov. 29, 1875 Yates, D. E., 9, *Rumford-place, and 38, Huskisson-street.*
- Nov. 13, 1876 Yates, Edward Wilson, 37, *Castle-street.*
- Nov. 2, 1874 Young, Henry, *South Castle-street.*

HONORARY MEMBERS.

LIMITED TO FIFTY.

- 1.—1838 The Right Hon. Dudley Ryder, Earl of Harrowby, K.G., D.C.L., F.R.S., etc., *Sandon Hall, Staffordshire*, and 89, *Grosvenor-square, London, W.*
- 2.—1836 The Most Noble William, Duke of Devonshire, K.G., M.A., F.R.S., D.C.L., F.G.S., etc., Chancellor of the University of Cambridge, *Chatsworth, Derbyshire, etc.*, and 78, *Piccadilly, London, W.*
- 3.—1838 Sir George Biddell Airy, K.C.B., M.A., LL.D., D.C.L., F.R.S., F.R.A.S., etc., Astronomer Royal, *Royal Observatory, Greenwich.*
- 4.—1840 James Nasmyth, F.R.S., *Penshurst, Kent.*
- 5.—1844 T. B. Hall, Esq., *Crane House, Yarmouth.*
- 6.—1844 Peter Rylands, M.P., *Warrington.*
- 7.—1844 Thomas Rymer Jones, F.R.S., F.Z.S., F.L.S., etc., 52, *Cornwall-road, Westbourne Park, London, W.*
- 8.—1844 William B. Carpenter, M.D., F.R.S., F.L.S., Corresponding Member of the Institute of France, etc., *London.*
- 9.—1850 The Rev. Canon St. Vincent Beechy, M.A., Rector of *Hilgay, Norfolk.*
- 10.—Henry Clark Pidgeon, 47, *Sutherland-gardens, Harrow-road, London, W.*
- 11.—1851 The Rev. Robert Bickersteth Mayor, B.D., Rector of *Frating, Essex.*
- 12.—1853 The Rev. James Booth, LL.D., F.R.S., F.R.A.S., etc., *The Vicarage, Stone, near Aylesbury.*
- 13.—1857 Thomas Joseph B. Hutchinson, F.R.G.S., F.R.S.L., F.E.S., *Callao, Peru.*
- 14.—1861 The Rev. Thomas P. Kirkman, M.A., F.R.S., Rector of *Croft, near Warrington.*
- 15.—1865 The Right Rev. T. N. Staley, D.D., late Bishop of Honolulu, Vicar of *Croxhall, Staffordshire.*

- 16.—1865 Edward J. Reed, C.B., M.P., *Hull*.
- 17.—1865 George Rolleston, M.D., F.R.S., Linacre Professor of Physiology in the University of Oxford, *Oxford*.
- 18.—1865 Cuthbert Collingwood, M.A., M.B., F.L.S., etc.
- 19.—1867 J. W. Dawson, LL.D., F.R.S., etc., Principal and Vice-Chancellor of McGill University, *Montreal*.
- 20.—1868 Captain Sir James Anderson, 16, *Warrington Crescent, Maida Hill, London, W.*
- 21.—1870 Sir John Lubbock, Bart., M.P., F.R.S., etc., *High Elms, Farnborough, Kent*.
- 22.—1870 Henry E. Roscoe, F.R.S., etc., *Owens College, Manchester*.
- 23.—1870 Professor Joseph Henry, Director of the Smithsonian Institution, *Washington, U.S.*
- 24.—1870 Sir Charles Wyville Thomson, F.R.S., etc., Professor of Natural History, *Edinburgh*.
- 25.—1870 Sir Joseph Dalton Hooker, M.D., F.R.S., etc., *Royal Botanic Gardens, Kew*.
- 26.—1870 Professor Brown Séquard, M.D.
- 27.—1870 John Gwyn Jeffreys, F.R.S., 25, *Devonshire-place, Portland-place, London, W.*
- 28.—1870 Professor Thomas H. Huxley, LL.D., F.R.S., etc., 26, *Abbey-place, St. John's Wood, London*.
- 29.—1870 Professor John Tyndall, LL.D., F.R.S., etc., *Royal Institution, London*.
- 30.—1870 The Rev. Christian D. Ginsburg, LL.D., *Binfield, Bracknell, Berks*.
- 31.—1874 Professor Alexander Agassiz, Director of the Museum of Comparative Zoology, *Harvard, Cambridge, Massachusetts*.
- 32.—1874 Professor Frederick H. Max Müller, LL.D., *Oxford*.
- 33.—1874 Sir Samuel White Baker, Pasha, F.R.S., F.R.G.S., etc., *Sandford Orleigh, Newton Abbot, Devonshire*.
- 34.—1877 Professor F. V. Hayden, M.D., etc., Director of the United States Geological and Geographical Survey of the Territories, *Washington*.

CORRESPONDING MEMBERS.

LIMITED TO THIRTY-FIVE.

- 1.—1867 Albert C. L. Günther, M.A., M.D., Ph.D., British Museum, Editor of the "Zoological Record."
- 2.—1867 J. Yate Johnson, *London*.
- 3.—1867 R. B. N. Walker, *Gaboon, West Africa*.
- 4.—1868 Rev. J. Holding, M.A., F.R.G.S., *London*.
- 5.—1868 George Hawkins, *Colombo, Ceylon*.
- 6.—1868 J. Lewis Ingram, *Bathurst, River Gambia*.
- 7.—1869 George Mackenzie, *Cebu, Philippine Islands*.
- 8.—1870 Rev. Joshua Jones, D.C.L., King William's College, *Isle of Man*.
- 9.—1874 Samuel Archer, Surgeon-Major, *Honduras*.
- 10.—1874 Samuel Booker, *Georgetown, Demerara*.
- 11.—1874 Coote M. Chambers, *Burrard's Inlet, British Columbia*.
- 12.—1874 Edwyn C. Reed, *Museo Nacional, Santiago de Chili*.
- 13.—1874 Millen Coughtrey, M.D., *New Zealand*.
- 14.—1875 Robert Gordon, Government Engineer, *British Burmah*.

ASSOCIATES.

LIMITED TO TWENTY-FIVE.

- 1.—Jan. 27, 1862 Captain John H. Mortimer, "America."
(Atlantic.)
- 2.—Mar. 24, 1862 Captain P. C. Petrie, "City of London,"
Commodore of the Inman Line of American
Steam Packets. (Atlantic.)
- 3.—Feb. 9, 1863 Captain James P. Anderson, R.M.S.S.
"Africa," Cunard Service. (Atlantic.)
- 4.—Feb. 9, 1863 Captain John Carr (Bushby and Edwards),
ship "Scindia." (Calcutta.)
- 5.—Feb. 9, 1863 Captain Charles E. Price, R.N.R. (L. Young
& Co.), ship "Cornwallis." (Calcutta and
Sydney.)
- 6.—April 20, 1863 Captain Fred. E. Baker, ship "Nippon."
(Chinese Seas.)
- 7.—Oct. 31, 1864 Captain Thomson, ship "Admiral Lyons."
(Bombay.)
- 8.—Oct. 31, 1864 Captain Alexander Browne (Papayanni), S.S.
"Agia Sofia." (Mediterranean.)
- 9.—April 13, 1865 Captain Alexander Cameron (Boult, English
& Brandon), ship "Staffordshire." (Shang-
hai.)
- 10.—Dec. 11, 1865 Captain Walker, ship "Trenton."
- 11.—Mar. 23, 1868 Captain David Scott.
- 12.—Oct. 5, 1868 Captain Cawne Warren.
- 13.—Oct. 5, 1868 Captain J. A. Perry.
- 14.—Mar. 22, 1869 Captain Robert Morgan, ship "Robin Hood."
- 15.—April 29, 1872 Captain J. B. Walker, Old Calabar.
- 16.—April 29, 1872 Captain Alfred Horsfall, S.S. "Canopus."
- 17.—Oct. 18, 1875 Captain John Slack.
- 18.—Feb. 19, 1877 Nevins, Arthur B.

ADDITIONS TO THE LIBRARY.

Date announced.	Donors.
1876.	
OCTOBER 16th.	
Diseases of the Hip, Knee, and Ankle Joints, by Hugh Owen Thomas : Liverpool, 1876 - -	<i>The Author.</i>
On the Theory of the Flow of Water, &c., by Robert Gordon ; Rangoon, 1875 - - -	<i>The Author.</i>
The Berwickshire Naturalists' Field Club :— Proceedings, vol. vii., part 3, 1875 - -	<i>The Club.</i>
The Natural History and Antiquarian Field Club, Bath :— Proceedings, vol. iii., part 3, 1876 - -	<i>The Club.</i>
The Naturalists' Society, Bristol :— Proceedings, vol. i., part 3, 1876 - -	<i>The Society.</i>
The Naturalists' Field Club, Belfast :— Proceedings, vol. i., parts ii. and iii., 1875-6	<i>The Club.</i>
The American Academy of Arts and Sciences, Boston :— Proceedings, vol. iii., 1875-6 - - -	<i>The Academy.</i>
The Society of Natural History, Boston :— Memoirs, 4to., vol. ii., part iv., nos. 2, 3, 4, 1875 - - - - -	<i>The Society.</i>
Occasional Papers, no. ii., 1876 - -	
Proceedings, vol. xvii., parts 3 and 4, 1875 ; vol. xviii., parts 1 and 2, 1876 - -	<i>The Society.</i>
L'Académie Royale des Sciences, des Lettres, et des Beaux-Arts, de Belgique, Brussels :— Bulletin, tomes xxxvii.-xl., 1874-5 - -	
Centième Anniversaire, tomes i.-ii., 1875 Annuaire, 1875-6 - - - -	<i>The Academy.</i>

- The Society of Natural Sciences, Buffalo :—
 Bulletin, vol. iii., part 2, 1876 - - - *The Society.*
- The Natural History Society, Chester :—
 Report, 1875 - - - - - *The Society.*
- The Geological Survey of India, Calcutta :—
- | | | |
|--|-----------|---|
| Memoirs, vol. xi., part 2, 1875 | - - - | } <i>The Governor
General in
Council.</i> |
| Records, vol. viii., 1875, and vol. ix., part 1,
1876 | - - - - - | |
| Palæontologia Indica, 4to., series ix., parts 2,
8, 4, 1875 | - - - - - | |
| | | |
- La Société Imperiale des Sciences Naturelles de
 Cherbourg :—
 Mémoires, tome xix., 1875 - - - *The Society.*
- The Philosophical Society, Glasgow :—
 Proceedings, vol. x., part 1, 1876 - - - *The Society.*
- The Royal Asiatic Society, London :—
 Journal, vol. viii., part 2, 1876 - - - *The Society.*
- The Society of Antiquaries, London :—
 Proceedings, vol. vi., parts 5 and 6, 1875-6 *The Society.*
- The Anthropological Institute, London :—
 Journal, nos. 15 and 16, 1876 - - - *The Institute.*
- The Royal Astronomical Society, London :—
 Monthly Notices, vol. xxxvi., parts 5 and 6,
 1876 - - - - - *The Society.*
- The Royal Geographical Society, London :—
 Proceedings, vol. xx., parts 3 to 6, 1876 -
 Journal, vol. xlv., 1875 - - - - - *The Society.*
- The Geological Society, London :—
 Journal, vol. xxxii., parts 2 and 3, 1876 - *The Society.*
- The Geologists' Association, London :—
 Proceedings, vol. iv., part 7, 1876 - *The Association.*
- The Linnæan Society, London :—
 Journal (Botany), nos. 83 to 85, 1876 ;
 (Zoology), nos. 63 to 65, 1876 - - - *The Society.*
- The Society of Arts :—
 Journal, London, to this date - - - *The Society.*

"Nature," "Science-Gossip," and the Quarterly Journal of Science, to this date - - *The Editors.*

OCTOBER 23rd.

- The Literary and Scientific Society, Birkenhead :—
 Report, 1875-6 - - - - *The Society.*
- The Chemical Society, London :—
 Journal, March-Sept., 1876 - - - *The Society.*
- The British Meteorological Society, London :—
 Journal, no. 18, 1876 - - - - *The Society.*
- The Institution of Civil Engineers, London :—
 Proceedings, vols. xliii. to xlv., 1876 - *The Institution.*
- The Royal Society, London :—
 Proceedings, nos. 168 to 172, 1876 - - *The Society.*
- The Statistical Society, London :—
 Journal, vol. xxxix., parts 1 and 2, 1876 - *The Society.*
- The East Indian Association, London :—
 Journal, vol. ix., parts 4 and 5, 1876 *The Association.*
- The Zoological Society, London :—
 Proceedings, in 1 vol., 1875 - - - *The Society.*
- The Geological Society of the West Riding, Leeds :
 Proceedings, no. 2, 1875 - - - - *The Society.*
- The Literary and Philosophical Society, Leicester :—
 Report, 1875 - - - - - *The Society.*
- The Town Museum, Leicester :—
 Report, 1875 - - - - - *The Trustees.*
- The Naturalists' Field Club, Liverpool :—
 Report, 1875 - - - - - *The Club.*
- The Athenæum Library, Liverpool :—
 Supplementary Catalogue, 1875 - - *The Committee.*
- The Powys-Land Club :—
 Catalogue and Collections, 1875 - - - *The Club.*
- The Literary Club, Manchester :—
 Papers, vol. ii., 1876 - - - - -
 Glossary of the Lancashire Dialect, by J. H.
 Nodal and G. Milner, part 1, 1875 - *The Club.*

Reale Istituto Lombardo, Milan:—

Memoires: i. Classe de Scienze, Mathe-
matiche, e Naturali; vol. xiii., Fasciolo 2,
1875; ii. Classe di Lettere e Scienze Morali
e Politiche; vol. xiii., Fasciolo 2, 1875;
iii. Rendiconti; vol. vii., Fasc. 17 to 20,
1874; vol. viii., Fasc. 1 to 20, 1875 - *The Institute.*

**The Connecticut Academy of Arts and Sciences,
New Haven:—**

Transactions, vol. iii., part 1, 1876 - - - *The Academy.*

The Union Society, Oxford:—

Speeches, Catalogue, &c., 1875 - - - *The Society.*

The Academy of Natural Sciences, Philadelphia:—

Proceedings, vol. for 1875 - - - *The Academy.*

The Franklin Institute, Philadelphia:—

Journal, vol. lxxi., 1876 - - - *The Institute.*

**The American Association for the Advancement
of Science, Salem:—**

Memoirs, 4to, vol. i., part 1, 1876 - *The Association.*

**L'Académie Royale Suédoise des Sciences, Stock-
holm:—**

Handlingar (Mémoires), 4to., vol. xi., 1875;
Bihang (Supplément aux Mémoires), vol.
iii., part 1, 1876; Ofversigt (Bulletin), vol.
for 1875 - - - - - *The Academy.*

The Canadian Institute, Toronto:—

Journal, vol. xv., parts 1 and 2, 1876 - *The Institute.*

Der Geographischen Gesellschaft, Wien:—

Mittheilungen, 1874-5 - - - - *The Society.*

"Nature," to date - - - - - *The Editor.*

NOVEMBER 4th.

Chemical and Physical Researches: by Thomas
Graham, F.R.S., &c., Edinburgh (for presenta-
tion only) - - - - - } James Young,
F.R.S., & Dr.
Angus Smith,
F.R.S.

- Liverpool Winds: Two Papers by W. W. Rundle, F.M.S. - - - - - *The Author.*
- Reports on the Physical, Descriptive, and Economic Geology of British Guiana: by C. B. Brown, F.G.S., and J. G. Sawkins, F.G.S. 1875 - - - - - *Samuel Booker, Esq.*
- The Ashmolean Society, Oxford:—
 On a new form of Polariscopes, by R. H. M. Bosanquet, M.A., &c. - - - - - *The Society.*
- The Yorkshire Philosophical Society, York:—
 Annual Report, 1875 - - - - - *The Society.*
- The U. S. Geological and Geographical Survey of the Territories, Washington:—
 Bulletin, vol. ii., parts 2-4, 1876 - - -
 Annual Report (New Mexico, &c.), 1874 *Dr. F. V. Hayden.*
- The Naval Observatory, Washington:—
 Astronomical and Meteorological Observations (4to.), 1878 - - - - - *Rear-Admiral Davis.*
- The Canadian Institute, Toronto:—
 Journal, vol. xv., part 8, 1876 - - - - - *The Institute.*
- The Somerset Archæological Society, Taunton:—
 Proceedings, N.S., vol. i., 1876 - - - - - *The Society.*
- The Royal Institution of Cornwall, Truro:—
 Journal, vol. xviii., 1876 - - - - - *The Institution.*
- The Essex Institute, Salem, Mass.:—
 Bulletin, vol. vii., 1875 - - - - - *The Institute.*
- The Franklin Institute, Philadelphia:—
 Journal, vol. lxxii., parts 1-4, 1876 - - - - - *The Institute.*
- The Philosophical and Literary Society, Leeds:—
 Transactions, 1875-6 - - - - - *The Society.*
- The Zoological Society, London:—
 Proceedings, 1876, parts 1-8 - - - - - *The Society.*
- The East Indian Association, London:—
 Journal, vol. x., part 1, 1876 - - - - - *The Association.*
- The Statistical Society, London:—
 Journal, vol. xxxix., part 8, 1876 - - - - - *The Society.*

- The British Meteorological Society, London :—
 Journal, no. 19, 1876 - - - - *The Society.*
- The Linnæan Society, London :—
 Journal (Botany), no. 86, 1876 - - - - *The Society.*
- The Geologists' Association, London :—
 Proceedings, vol. iv., part 8, 1876 - *The Association.*
- The Chemical Society, London :—
 Journal, October, 1876 - - - - *The Society.*
- The Anthropological Institute, London :—
 Journal, no. 17, 1876 - - - - *The Institute.*
- Der Königlichen Physikalisch-ökonomischen Gesell-
 schaft, zu Königsberg :—
 Schriften, Sechszehnter Jahrgang, 1875 - *The Society.*
- The Literary and Philosophical Society, Hull :—
 Proceedings, 1875-6 - - - - *The Society.*
- The Royal Asiatic Society, Bombay :—
 Journal, nos. 82-88, 1873 - - - - *The Society.*
- The Society of Arts, London :—
 Journal, to date - - - - *The Society.*
- "Nature," London, Oct. 17th and 24th - - - *The Editor.*

 DECEMBER 4th.

- On Thrombosis and Embolism, by James Turn-
 bull, M.D. : London, 1876 - - - - *The Author.*
- Two Papers on the Glacial Period, by James Croll,
 LL.D., F.R.S. : Edinburgh, 1876 - - - *The Author.*
- The Museum of Comparative Zoology, Cambridge,
 Mass. :—
 Memoirs (4to.), vol. ii., part 9 - - - -
 On some Insect Deformities, by A. H. Hagen,
 1876 - - - -
 Bulletin, vol. iii., parts 11-16, 1876 - - - *The Trustees.*
- The Peabody Museum of American Archæology,
 Cambridge, Mass. :—
 Report, 1868-74 - - - - *The Trustees.*

- The Royal Scottish Society of Arts, Edinburgh :—
 Report, 1875-6 - - - - - *The Society.*
- The Royal Cornwall Polytechnic Society, Falmouth :—
 Report, vol. xliii., 1875 - - - - - *The Society.*
- The Royal Astronomical Society, London :—
 Monthly Notices, vol. xxxvi., parts 6-9, 1876 *The Society.*
- The Institution of Civil Engineers, London :—
 Proceedings, vol. xli., 1876 - - - *The Institution.*
- The Chemists' Association, Liverpool :—
 Report, 1875-6 - - - - - *The Association.*
- The Literary and Philosophical Society, Manchester :—
 Memoirs (8rd series), vol. v., 1876 - - -
 Proceedings, vol. xv., 1875-6, and Catalogue
 of Library - - - - - *The Society.*
- The Plymouth Institute, Plymouth :—
 Transactions, 1875-6 - - - - - *The Institute.*
- The Franklin Institute, Philadelphia :—
 Journal, vol. lxxii., part 5, 1876 - - - *The Institute.*
- The United States Geological and Geographical
 Survey, Washington :—
 Memoirs (4to.), vol. ix. - - - - -
 On Invertebrate Cretaceous Fossils, by F. B.
 Meek, 1876 - - - - -
 Memoirs, vol. x. - - - - -
 A Monograph of the Geometrid Moths, or Pha-
 lænidæ, by A. S. Packard, Jun., 1876 *Dr. F. V. Hayden.*

1877.

JANUARY 1st.

- The Massachusetts Board of Agriculture :—
 Annual Report, Boston, 1876 - - - - - *The Board.*
- The Museum of Comparative Zoology, Cambridge,
 Mass. :—
 Memoirs (4to.), vol. iv., part 10 - - - - -
 On the American Bisons, by J. A. Allen, 1876 *The Trustees.*

- The Society of Antiquaries :—**
 Proceedings, vol. vii., part 1, London, 1876 *The Society.*
- The Chemical Society :—**
 Journal, London, November and December,
 1876 - - - - - *The Society.*
- The Geological Society :—**
 Journal, vol. xxxii., part 4, London, 1876 *The Society.*
- The Royal Society :—**
 Proceedings, nos. 173-4, London, 1876 - *The Society.*
- The Royal Medico-Chirurgical Society :—**
 Transactions, vol. lix., London, 1876 - *The Society.*
- The American Philosophical Society :—**
 Proceedings, nos. 96, 97, Philadelphia, 1876 *The Society.*
- The Natural History Society and Field Club :—**
 Transactions, vol. i., parts 4 and 5, Watford,
 1876 - - - - - *The Society.*
- “ Science-Gossip,” “ Nature,” - - - - - *The Editors.*
- The Society of Arts :—**
 Journal, London, to this date - - - *The Society.*
-

JANUARY 15th.

- La Société des Sciences Physiques et Naturelles :—**
 Mémoires, 2e Série, 8e Cahier, Bordeaux, 1876 *The Society.*
- The Botanical Society :—**
 Proceedings, vol. xii., part 3, Edinburgh, 1876 *The Society.*
- The Meteorological Society of Scotland :—**
 Journal, nos. 49, 50, Edinburgh, 1876 - *The Society.*
- The Royal Astronomical Society :—**
 Monthly Notices, vol. xxxvii., part 1.,
 1876 - - - - - *The Society.*
- The Geologists' Association :—**
 Proceedings, vol. iv., part 9, London, 1876 *The Association.*
- The Linnæan Society :—**
 Proceedings (Botany), no. 87 - - - -
 Proceedings (Zoology), no. 66, London, 1876 *The Society.*

The Numismatic Society :—

Journal, 8vo. and 4to., vol. ii., part 1, Liverpool, 1876 - - - - - *The Society*

The Powys-land Club :—

Collections, vols. vi.—ix., Liverpool, 1878-8 *The Club.*

The Royal Geological Society of Cornwall :—

Report, no. 62, Penzance, 1876 - - - *The Society.*

The Franklin Institute ;—

Journal, vol. lxxii., part 6, Philadelphia, 1876 *The Institute.*

“Nature,” London, Jan. 4th and 11th, 1877 - *The Editor.*

JANUARY 29th.

Ueber das Auftreten der Wanderheuschrecke am Vfer des Bierlersee's, von Albert Müller in Basel, 1876 - - - - - *The Author.*

Mineral Map and General Statistics of New South Wales, by A. Liversidge, Sydney, 1876 - *The Author.*

Les Bateaux Héli Plongeurs. par Donato Tommasi, Docteur des Sciences, &c. : Paris, 1876 - *The Author.*

Progress: Notes on Systems of Education, by S. Leigh-Gregson, Liverpool, 1876 - - *The Author.*

Dun Echt Observatory Publications, vol. i., 4to. ;—

A Summary or Index of the Measurements in the “Stellarum Duplicium et Multiplicium Mensuræ Micrometricæ,” Struve, 1887 ; “Additamentum in F. G. W. Struve Mensuras Micrometricas Stellarum Duplicium,” 1887-40, &c., arranged in order of R.A., and the positions brought up to 1875, Aberdeen, 1876 - - *Lord Lindsay, F.R.A.S.*

The Royal Astronomical Society :—

Monthly Notices, vol. xxxvii., no. 2, London, 1876 - - - - - *The Society.*

The Chemical Society :—

Journal, Jan., 1877 : London - - - *The Society.*

The Royal Microscopical Society :—

Journal, vols. xv.—xvi., London, 1876 - *The Society.*

The Literary and Philosophical Society, Leicester :—

Address by the Rev. A. Mackennal, B.A.,
President, on Education and Culture, 1876 *The Society.*

The Canadian Institute :—

Journal, vol. xv., part 4, Toronto, Jan. 1877 *The Institute.*

"Nature," London, Jan. 11th and 18th, 1877 - *The Editor.*

The Society of Arts :—

Journal, London, Jan. 12th and 19th, 1877 *The Society.*

FEBRUARY 12th.

La Première Campagne de la Crimée, ou les
Batailles mémorables de l'Alma, de Balaclava,
et d'Inkerman, par Austin Layard, Traduit
par Miss A. E. S. Jervis, Bruxelles, 1855 -

Mrs. A. E. S. Guerritore (nee Jervis).

The Local Committee of the British Association,
Glasgow :—

1. On the Industries of Glasgow and of the
Clyde Valley. 2. On the Western Scottish
Fossils. 8. The Fauna and Flora of
Western Scotland - - - *The Committee.*

Smithsonian Institution, Washington :—

Smithsonian Contributions to Knowledge,
4to., vol. xx. On the Winds of the Globe,
by James Henry Coffin, LL.D.; com-
pleted after the Author's decease, by Selden
Jennings Coffin, M.A., with a Discussion
and Analysis of the Tablets and Charts, by
Dr. Alexander Woeikof, Washington, 1875.
Vol. xxi., containing : 1. Statement and
Exposition of certain Harmonies of the
Solar System, by Stephen Alexander, LL.D.

2. On the General Integrals of Planetary Motion, by Simon Newcomb. 3. The Haidah Indians of Queen Charlotte Islands, British Columbia, by James G. Swan.
4. Tables, Distribution, and Variations of Atmospheric Temperature in the United States, and some adjacent parts of North America, collected by the Smithsonian Institution, and discussed under the direction of Professor Joseph Henry, Secretary, by C. A. Schott, Washington, 1876 - *The Institution.*
- The Franklin Institute :—
Journal, vol. lxxiii., part 1, Philadelphia, 1877 - - - - - *The Institute.*
- The Free Public Library, Museum, and Gallery of Art :—
Twenty-fourth Annual Report, Liverpool, 1876-7 *The Committee.*
- The Statistical Society :—
Journal, vol. xxxix., part 4, London, 1876 - *The Society.*
- The Royal Institution :—
Proceedings, vol. viii., parts 1-2, London, 1876 - - - - - *The Institution.*
- The British Meteorological Society :—
Journal, no. 20, London, 1876 - - - *The Society.*
- The Royal Geographical Society :—
Proceedings, vol. xxi., part 1, London, 1877 - - - - - *The Society.*
- The Royal Astronomical Society :—
Monthly Notices, London, Jan. 7, 1877 - *The Society.*
- The Anthropological Institute :—
Journal, no. 18, London, 1877 - - - *The Institute.*
- The Royal Asiatic Society :—
Journal, vol. ix., part 1, London, 1876 - *The Society.*
- The Royal Society :—
Proceedings, 1875-6, Edinburgh, 1877 - *The Society.*

The Society of Arts :—

- Journal, Jan. 26th and Feb. 2nd and 9th,
 London, 1877 - - - - - *The Society.*
 "Nature," London, Feb. 1st and 8th, 1877 ;
 "Science-Gossip," London, Feb., 1877 ;
 "Quarterly Journal of Science," London,
 Jan., 1877 - - - - - *The Editors.*

FEBRUARY 26th.

The Harvard University :—

- Annual Report, 1875-6, Cambridge, Mass.,
 1876 - - - - - *The Senate.*

Det Kongelige Norske Universitet :—

1. Quellen zur Geschichte des Taufsymbols
 und der Glaubensregel, von C. P. Caspari,
 bandet iii., Christiania, 1875. 2. Transfu-
 sion und Plethora, von Jacob W. Müller,
 Christiania, 1876 - - - - - *The Senate.*

The Royal Society :—

- Proceedings, nos. 175-6, London, 1877 - *The Society.*

The Literary Club :—

- Transactions, vol. i., Manchester, 1875 - *The Club.*

The Lyceum of Natural History, New York :—

- Annals, vol. x., parts 12-14, 1874 ; vol. xi.,
 parts 1-8, 1875 ; Proceedings, 1873-5 - *The Lyceum.*

The American Association for the Advancement of
 Science :—

- Proceedings, vol. xxiv., Salem, Mass., 1875 *The Association.*

The Smithsonian Institution :—

- Report, 2 vols., Washington, 1854-5 - *The Institution.*
 "Nature," London, Feb. 16th and 23rd, 1877 - *The Editor.*

The Society of Arts :—

- Journal, Feb. 17th and 24th, London,
 1877 - - - - - *The Society.*
-

MARCH 12th.

The Strassburg University :—

De Solœcismo, Commentatio Philologica quam scripsit, G. Schepss, Argentorati, 1875.
 Quos Auctores in ultimis Belli Peloponnesi-
 aci annis describendis secuit sint Diodorus
 Plutarchus Cornelius Justinus, scripsit,
 Paulus Natorp, Argentorati, 1876. Etude
 sur le Vocalisme des Patois Romans du
 Canton de Fribourg, par François Haefelin,
 Leipsig, 1876. Theopompea, Carolus
 Buenger, Argentorati, 1874. Die Ver-
 schiebung Lateinischer Tempora in den
 Romanischen Sprachen, von Karl Foth,
 Strassburg, 1876. Jacob Sturm von Stur-
 meck, Strassburgs grosser Stettmeister
 und Scholarch, von Professor D. Baum,
 Strassburg, 1874. Die Neugründung der
 Strassburger Bibliothek, Strassburg, 1871.
 Die Einweihung der Strassburger Univer-
 sität, Officieller Festbericht, Strassburg,
 1872. Zur Geschichte der Univesität
 Strassburg, von Dr. August Schricker.
 Strassburgh, 1872. Der Rectoratswechsel
 an der Universität Strassburg, 1874. Die
 Kaiserliche Universitäts-und Landesbiblio-
 thek in Strassburg, ein Vortrag von C. G.
 Hottinger, Strassburg, 1875 - - - *The Senate.*

The Franklin Institute :—

Journal, vol, lxxviii., part 2, Philadelphia, 1877 *The Institute.*

The British Meteorological Society :—

Journal, no. 21, London, 1877 - - *The Society.*

The Literary and Philosophical Society :—

Report, 1876, Whitby - - - *The Society.*

The Geological Society :—

Journal, vol. xxxiii., part 1, London, 1877 - *The Society.*

The Geologists' Association :—

Report, 1876, London, 1877 - - *The Association.*

The Chemical Society :—

Journal, London, February, 1877 - - *The Society.*

The Institution of Civil Engineers :—

Proceedings, vol. xlvii., London, 1877 *The Institution.*

The Society of Arts :—

Journal, London, February 28rd and March

2nd, 1877 - - - - - *The Society.*

"Nature," London, Feb. 22nd and March 1st,

1877 - - - - - *The Editor.*

MARCH 31st.

"Greenwich Observations" during 1874, London,

1877 - - - - - *The Government.*

The Royal Astronomical Society :—

Monthly Notices, vol. xxxvii., part 4, London,

1877 - - - - - *The Society.*

The Chemical Society :—

Journal, London, 1877 - - - - - *The Society.*

The Royal Geographical Society :—

Proceedings, vol. xxi., part 2, London, 1877 *The Society.*

The Society of Arts :—

Journal, London, March, 1877 - - - *The Society.*

"Nature," London, March 15th and 22nd, 1877 *The Editor.*

APRIL 9th.**La Société Nationale des Sciences Naturelles de Cherbourg :—**

Compte-Rendu de la Séance Extraordinaire

tenue par la Société le 30 Décembre, 1876,

a l'occasion du vingt-cinquième anniver-

saire de sa fondation, Cherbourg, 1877 -

The Society.

The Royal Scottish Society of Arts :—

Transactions, vol. ix., part 4, Edinburgh, 1877 *The Society.*

- The Royal Geographical Society :—
 Proceedings, vol. xxi., part 8, London,
 1877 - - - - - *The Society.*
- The Linnæan Society :—
 Journal (Botany), no. 88 ; Journal (Zoology),
 no. 67 ; London, 1877 - - - - *The Society.*
- The Royal Society :—
 Proceedings, nos. 177–178, London, 1877 - *The Society.*
- The Historic Society of Lancashire and Cheshire :—
 Transactions, 3rd series, vols. iii.–iv., Liver-
 pool, 1874–6 - - - - *The Society.*
- The Powys-land Club :—
 Collections, vol. x., part 1, Liverpool, 1877 *The Club.*
- The Natural History Society of Northumberland
 and Durham :—
 Transactions, vol. v., part 8, Newcastle-on-
 Tyne, 1876 - - - - *The Society.*
- The Astor Library, New York :—
 Report, 1876 - - - - *The Trustees.*
- The American Geographical Society :—
 Bulletin, no. 2, New York, 1877 - - *The Society.*
- The Franklin Institute :—
 Journal, vol. lxxiii., part 8, Philadelphia,
 1877 - - - - *The Institute.*
- “The Quarterly Journal of Science,” London,
 April, 1877, and “Nature,” London, to date *The Editors.*

APRIL 23rd.

- Narrative of the Discovery of the Great Central
 Lakes of Africa, by J. L. Clifford Smith,
 F.R.G.S., Halifax, 1877 - - - - *The Author.*
- Description of some new Sponges, obtained during
 a Cruise of the steam yacht “Argo” in the
 Caribbean and neighbouring Seas, by T. Higgin,
 F.L.S., 1877 - - - - *The Author.*

- On the Origin and Vicissitudes of Literature,
Science, and Art, and their Influence on the
Present State of Society; a Discourse delivered
on the Opening of the Royal Institution, by
William Roscoe, Liverpool, 1817 - - *A. Higginson, Esq.*
- The Royal Astronomical Society :—
Monthly Notices, vol. xxxvii., part 5, London,
1877 - - - - - *The Society.*
- The East Indian Association :—
Journal, vol. x., part 2, London, 1877 *The Association.*
- “The Quarterly Journal of Science,” London, April,
1877; “Science-Gossip,” London, April, 1877;
and “Nature,” London, April 6th, 18th, and
20th, 1877 - - - - - *The Editors.*
- The Society of Arts :—
Journal for April, London, 1877 - - *The Society.*
- The Franklin Institute :—
Journal, vol. lxxiii., parts 8-4, Philadelphia,
1877 - - - - - *The Institute.*
- The Royal Institution of Cornwall :—
Report, Truro, 1877 - - - *The Institution.*

LIST OF SOCIETIES, ACADEMIES, INSTITUTIONS, ETC.
TO WHICH THIS VOLUME IS PRESENTED.

(The Asterisk denotes those from which Donations have been received this Session.)

- Aberdeen* . . . *The Dun-Echt Observatory.
Alnwick . . . *The Berwickshire Naturalists' Field Club.
Bath . . . *The Natural History and Antiquarian Field Club.
Belfast . . . *The Naturalists' Field Club.
Belfast . . . *The Natural History and Philosophical Society.
Bristol . . . *The Naturalists' Society.
Birkenhead . . . The Free Public Library.
Birkenhead . . . *The Literary and Scientific Society.
Bordeaux . . . *La Société des Sciences Physiques et Naturelles.
Bombay . . . *The Royal Asiatic Society.
Boston (Mass.) . *The American Academy of Arts and Sciences.
Boston (Mass.) . *The Natural History Society.
Boston (Mass.) . *The Massachusetts Boards of Agriculture, Education, State Charities, and Health.
Boston (Mass.) . The Free Public Library.
Buffalo (N. Y.) . *The Society of Natural Sciences.
Burlington (Vt.) . *The Orleans County Society of Natural Sciences.
Brussels . . . *L'Académie Royale des Sciences, des Lettres, et des Beaux-Arts de Belgique.
Chester . . . *The Natural History Society.
Chester . . . The Architectural and Archæological Society.
Cambridge . . . The Philosophical Society.
Cambridge (Mass.) *The Harvard University.

- Cambridge (Mass.)* *The Museum of Comparative Zoology.
Cambridge (Mass.) *The Peabody Museum of American Archæology.
- Canterbury* . . . The Union Society.
- Calcutta* . . . *The Asiatic Society of Bengal.
- Calcutta* . . . *The Geological Survey of India.
- Cherbourg* . . . *La Société Imperiale des Sciences Naturelles.
- Chicago* . . . The Public Library.
- Christiana* . . . *The University.
- Copenhagen* . . . L'Académie Royale.
- Copenhagen* . . . La Société Royale des Antiquaries du Nord.
- Davenport (Iowa)* . *The Academy of Natural Sciences.
- Dublin* . . . *The Royal Irish Academy.
- Dublin* . . . *The Royal Geological Society of Ireland.
- Dublin* . . . The Royal Society.
- Edinburgh* . . . *The Royal Scottish Society of Arts.
- Edinburgh* . . . *The Botanical Society.
- Edinburgh* . . . *The Meteorological Society of Scotland.
- Edinburgh* . . . *The Royal Physical Society.
- Edinburgh* . . . *The Royal Society.
- Edinburgh* . . . The Philosophical Institution.
- Edinburgh* . . . *The Geological Society.
- Falmouth* . . . *The Royal Cornwall Polytechnic Society.
- Glasgow* . . . *The Philosophical Society.
- Glasgow* . . . *The Geological Society.
- Greenwich* . . . *The Royal Observatory.
- Göreswäld* . . . The University.
- Hull* . . . *The Literary and Philosophical Society.
- Halifax* . . . *The Literary and Philosophical Society.
- Königsberg* . . . *Der Königlichen Physikalisch-ökonomischen Gesellschaft.
- London* . . . *The Society of Arts.
- London* . . . *The Royal Asiatic Society.
- London* . . . *The Society of Antiquaries.
- London* . . . *The Anthropological Institute.
- London* . . . *The Royal Astronomical Society.

- London* The British Association.
London The British Museum.
London *The Chemical Society.
London The Clinical Society.
London *The Royal Geographical Society.
London *The Geological Society.
London *The Geologists' Association.
London *The Linnæan Society.
London *The British Meteorological Society.
London *The Royal Society of Literature.
London *The Royal Society.
London *The Royal Institution.
London *The Statistical Society.
London *The Medico-Chirurgical Society.
London *The Institution of Civil Engineers.
London *The Royal Institute of British Architects.
London *The Royal Microscopical Society.
London *The East Indian Association.
London *The Zoological Society.
London *The Editor of "Nature."
London *The Editor of "Quarterly Journal of Science."
London *The Editor of "Science Gossip."
London The Editor of "Geological Magazine."
Leeds *The Philosophical and Literary Society.
Leeds *The Geological Society of West Riding of Yorkshire.

Liverpool *The Architectural Society.
Liverpool *The Historic Society.
Liverpool *The Geological Society.
Liverpool *The Philomathic Society.
Liverpool The Polytechnic Society.
Liverpool *The Naturalists' Field Club.
Liverpool The Microscopical Society.
Liverpool The Chemists' Association.
Liverpool *The Numismatic Society.
Liverpool The Royal Institution.

<i>Liverpool</i>	. . .	*The Free Public Library.
<i>Liverpool</i>	. . .	The Medical Institution.
<i>Liverpool</i>	. . .	The Lyceum News Room.
<i>Liverpool</i>	. . .	The Athenæum Library and News Room.
<i>Liverpool</i>	. . .	The Liverpool Library.
<i>Liverpool</i>	. . .	*The Powys-land Club.
<i>Leicester</i>	. . .	*The Literary and Philosophical Society.
<i>Manchester</i>		*The Literary and Philosophical Society.
<i>Manchester</i>	. . .	The Free Public Library.
<i>Manchester</i>	. . .	The Chetham Library.
<i>Manchester</i>	. . .	*The Owens College.
<i>Manchester</i>	. . .	*The Literary Club.
<i>Melbourne</i>	. . .	*The Royal Society of Victoria.
<i>Milan</i>	. . .	*La Reale Istituto Lombardo.
<i>Newcastle-on-Tyne</i>		*Natural History Society.
<i>New York</i>	. . .	*The Astor Library.
<i>New York</i>	. . .	*The American Geographical Society.
<i>New York</i>	. . .	*The Academy of Sciences.
<i>New York</i>	. . .	The City University.
<i>New York</i>	. . .	The State University.
<i>New York</i>	. . .	*The State Library.
<i>New York</i>	. . .	*The State Museum of Natural History.
<i>New Haven</i>	. . .	*The Connecticut Academy of Arts and Sciences.
<i>Oxford</i>	. . .	*The Ashmolean Society.
<i>Oxford</i>	. . .	*The Union Society.
<i>Otago</i>	. . .	The University.
<i>Ottawa</i>	. . .	The Library of Parliament.
<i>Plymouth</i>	. . .	*The Plymouth Institute.
<i>Penzance</i>	. . .	*The Royal Geological Society of Cornwall.
<i>Philadelphia</i>	. . .	*The American Philosophical Society.
<i>Philadelphia</i>	. . .	*The Academy of Natural Sciences.
<i>Philadelphia</i>	. . .	*The Franklin Institute.
<i>Philadelphia</i>	. . .	*The Zoological Society.
<i>Philadelphia</i>	. . .	*The Pennsylvania Board of Public Education.
<i>Salem (Mass.)</i>	. . .	*The Essex Institute.

- Salem (Mass.)* . . . *The American Association for the Advancement of Science.
- Stockholm* . . . *L'Académie Royale Suedoise des Sciences.
- Southport* . . . The Literary and Philosophical Society.
- Strasburg* . . . *La Bibliothèque Municipale.
- Strasburg* . . . *Die Kaiserliche Universitäts-und Landesbibliothek.
- Truro* . . . *The Royal Institution of Cornwall.
- Taunton* . . . *The Somersetshire Archæological Society.
- Toronto* . . . *The Canadian Institute.
- Vienna* . . . *Der Geographischen Gesellschaft.
- Whitby* . . . *The Literary and Philosophical Society.
- Washington* . . . *The Naval Observatory.
- Washington* . . . The Department of Patents.
- Washington* . . . *The Department of Agriculture.
- Washington* . . . *The Smithsonian Institution.
- Washington* . . . *The War Office.
- Washington* . . . *The Geological and Geographical Survey of the Territories.
- York* . . . *The Philosophical Society.

TREASURER'S ACCOUNT, 1875-6.

Dr.

The LIBRARY AND PHILOSOPHICAL SOCIETY, in Account with R. C. JOHNSON, Treasurer.

Cr.

	£	s.	d.
1875-6.			
To Balance brought forward.....	62	4	8
To Cash paid D. Marples & Co., Limited (Printing)	147	11	6
" " G. G. Walsley (Printing)	6	9	0
" " Tining & Co., ditto	10	1	6
" " Printing & Stationery Co.	0	10	9
" " G. S. Wood	0	5	6
" " Mrs. Johnson (Teas)	26	18	0
" " S. Burke (Attendance)	1	17	6
" " Secretary (Expenses)	16	1	6
" " " (Editorial Fee)	10	10	0
" " Librarian for Carriage of Parcels	3	7	1
" " Treasurer for Sundries	0	10	6
To Balance in hand (Dock Bond).....	250	0	0
	£585	7	1
To Balance	64	9	8

	£	s.	d.
1874-5.			
By Balance brought forward :—			
Dock Bond	2250	0	0
By Cash paid for Subscriptions :—			
179 Annual, at 2ls.	187	19	0
1 Half do. at 10s. 6d.	0	10	6
24 Entrance, at 10s. 6d.	12	12	0
18 Arrears, at 2ls.	18	18	0
	219	19	6
By Cash, Interest on Dock Bonds	10	17	11
By Balance	54	9	8
	£585	7	1

Examined and found correct,

C. H. STEARN,
EDWARD DAVIES.

PROCEEDINGS
OF THE
LIVERPOOL
LITERARY AND PHILOSOPHICAL SOCIETY.

ANNUAL MEETING.—SIXTY-SIXTH SESSION.

ROYAL INSTITUTION, October 2nd, 1876.

JAMES ALLANSON PICTON, F.S.A., PRESIDENT,
in the Chair.

The Minutes of the last Meeting of the previous Session were read and confirmed, and the Honorary Secretary then read the following

REPORT.

“The affairs of the Literary and Philosophical Society of Liverpool continue to be in a satisfactory condition; the Ordinary Meetings are numerous attended, and the roll of members, though slightly decreased, is still considerable. At the commencement of the Session the Ordinary Members numbered two hundred and thirty-one. The deaths of seven, and the resignations of twenty-three, the majority of whom left the neighbourhood, reduced the number to two hundred and one; but the election of twenty-three new members raised the number to two hundred and twenty-four, which constitutes the present strength of the Society.

“Of the gentlemen deceased, the Society has especially to lament the loss of two of its most prominent members—Dr. Inman, one of the Ex-Presidents, and Mr. Arnold Baruchson, formerly one of the Vice-Presidents.

“Dr. Inman’s membership had extended over the space of thirty-two years, and had been distinguished by many valuable services to the Society, not only in the offices which he had held, first as Honorary Secretary, and afterwards as President, but in contributions to its *Proceedings* and in donations to its Library. In the Index of Authors, annexed to the twenty-sixth volume of the Society’s *Proceedings*, Dr. Inman’s name appears at the head of sixteen papers down to 1871, since which year he has contributed two others, one of which was read only in the last Session. The donations which Dr. Inman presented to the Society consisted of his own works, which were numerous, and of the *Annual Report of the British Association*—a volume which he never failed to place before the members at the earliest opportunity after its publication. The geniality and good humour which he threw into the discussions of the Society marked his conduct as President, and the Council feel that his loss is one which cannot readily be repaired.

“Mr. Arnold Baruchson, whose death the Council has likewise to record, had been connected with the Society for fourteen years, and had also contributed papers to its *Proceedings*. He was a very frequent attendant at the Ordinary Meetings, and always took an active interest in the Society’s concerns.

“Among the gentlemen whose connexion with the Society has been terminated by their removal to other localities, the name of the Rev. Dr. Kennedy-Moore, recently a Vice-President, demands honourable mention in this Report. His contributions to the *Proceedings* were both learned and

graceful, and the readiness and ability with which he entered into almost every discussion at the Ordinary Meetings will long be remembered.

“The number of Honorary Members now on the Society’s roll is thirty-seven; of the Corresponding Members, fourteen; and of the Associates, seventeen.

“The Society continues to receive many valuable donations from the Associations and Institutions with which it exchanges *Proceedings*, and the number of these has increased during the last twelve months. The Council, therefore, has much pleasure in again directing the attention of the members to the many rare and excellent works which are at their disposal.

“Towards the close of the last Session, the Council received an intimation from the Committee of the Royal Institution that the Society could no longer be favoured with the free use of rooms in their building, and that, with the commencement of the Session of 1876–77, a rental of £20 per annum would be required. This serious call upon the Society’s resources, after it has been in the free and undisturbed occupation of the said rooms for nearly sixty years, has taken up much of the time and attention of your Council since it was first made. A representation of all the circumstances under which the Society was freely located in the Royal Institution has been made to the Committee, and they have promised to reconsider their demand at their next meeting. Understanding, however, from the Rev. H. H. Higgins, that the payment of an annual contribution would be acceptable under present circumstances to the Royal Institution, your Council have to recommend that the sum of £20 be so contributed, in acknowledgment of the use of the rooms as at present occupied by this Society.

“The Council have now to conclude their Report with the customary recommendation of five gentlemen for election on

the new Council. They have selected the following:— Messrs. Higgin, Young, Palmer, Josiah Marples, and Hayward.”

The Report was approved of and adopted, on the motion of Mr. Alfred Higginson, seconded by Mr. Isaac Roberts.

The Hon. Treasurer next submitted his Annual Statement of Accounts, which was passed, on the motion of Mr. Birch, seconded by Mr. Kinsman.

The election of Office-bearers and Members of Council was then proceeded with, and the following gentlemen elected: Vice-Presidents— Alfred Higginson, M.R.C.S., Thomas J. Moore, Cor. Mem. Z.S.L., John J. Drysdale, M.D., M.R.C.S.; Honorary Treasurer—Richard C. Johnson, F.R.A.S.; Honorary Secretary—James Birchall; Honorary Librarian—Alfred Morgan; Members of Council—J. Campbell Brown, D.Sc., &c., Alfred E. Fletcher, F.C.S., W. Carter, M.B., Rev. E. M. Geldart, M.A., Edward R. Russell, Edward Davies, F.C.S., C. H. Stearn, George H. Morton, F.G.S., Baron Louis Benas, Thomas Higgin, F.L.S., John Linton Palmer, F.S.A., F.R.G.S., Josiah Marples, John W. Hayward, M.D., Sibley Hicks, F.R.C.S.

The Associates of the Society were next re-elected.

It was then moved by the Honorary Secretary, seconded by Mr. A. Higginson, and carried:—“That in consequence of the Meeting of the Social Science Congress in Liverpool, the first Ordinary Meeting of the Society should be adjourned to the 24th of October; the succeeding meetings following in due course of law.”

The President then read his Second Inaugural Address,* for which a vote of thanks was carried by acclamation, on the motion of the Rev. H. H. Higgins, seconded by the Rev. E. M. Geldart.

Ladies were present at this Meeting.

* See page 1.

FIRST ORDINARY MEETING.

ROYAL INSTITUTION, October 24th, 1876.

JAMES A. PICTON, F.S.A., PRESIDENT, in the Chair.

The Rev. Dr. Stearn was elected an Ordinary Member.

A *Conversazione* on Natural Science was then held, and the following subjects were brought before the Society :—

ARGO COLLECTION.

Numerous specimens were exhibited from the collection made for the Liverpool Free Public Museum by the Rev. H. H. Higgins, during his recent cruise in the West Indian Seas, as the guest of Mr. Reginald Cholmondeley, of Condover Hall, on board the Royal Mersey Steam Yacht *Argo*.*

The following communication was read :—

ON THE SPONGES OF THE ARGO EXPEDITION.

BY THOMAS HIGGIN, F.L.S.

The Sponges which we have before us this evening are most of them perfect examples of rare and not easily obtained species, and some of them are new to science.

The large collection brought home by the Rev. Mr. Higgins from the various places visited by the "*Argo*," from which those we now see have been selected, will require months of patient work before the different specimens can be described and named. They are in excellent condition, having the sarcode preserved with the skeleton, either in a dried state or in spirits, and they therefore possess all the

* See page 406 for the history of this Expedition.

microscopic parts necessary for the distinguishing of species. It is, unfortunately, too often the case with specimens offered by dealers, that they have been ruined by the washing to which they have been subjected, with the intention of cleaning them and giving them a better appearance; but the "Argo" Sponges, dredged by Mr. Higgins, are all in the best state of preservation, and they therefore possess a value which they would not have had if they had been obtained by a less experienced collector. The careful examination of them may be expected to produce many new species.

Dactylocalyx pumiceus.—The large, rigid, glassy, cup-shaped Sponge, from Grenada, is an excellent example of the species known by this name, and it is probably the first specimen which has been brought to this country with the sarcode about it. In a small portion sent to Mr. H. J. Carter, F.R.S., he has been able to ascertain that a fine lattice-work of small hexradiate spicules covers the whole surface of the Sponge, supporting the dermal sarcode, a feature which the examination of other similar species led him to look for, but which is not observable in the previously known specimens denuded of their sarcode, together with its fine spicules. This Sponge belongs to the group styled by Professor Wyville Thomson, *Vitreous Sponges*, and to the family which Mr. H. J. Carter has named *Vitreo-hexactinellida*. The spicules, as this name denotes, are of the hexradiate or six-rayed type, and those which form the skeleton are surrounded and held together by amorphous siliceous material, deposited about them after they have been placed in position by the sponge organism, and thus the rigid, glassy structure is produced.

Almost all Sponges possess a skeleton for the support of the soft parts of the body; in the case of the Sponge of commerce, the skeleton is a network of resilient horny material, which yields to pressure, and resumes its natural

form again so soon as the pressure is withdrawn ; in another family, of which we have an example before us in the beautiful yellow Sponge of tubulo-digitate form, also from Grenada, the skeleton is less elastic than that of the common Sponge, the want of elasticity being due to the presence of siliceous spicules lying in the horny material. In other species we find this core of siliceous material increasing in amount until almost all the horny material has been displaced by it, and the entire network is a mass of these raphides-like bodies, held together by a minimum quantity of horny material ; and such Sponges consequently possess only that small amount of elasticity afforded by the hardened sarcode, which in them exists in quantity barely sufficient to hold the spicules together. In the vitreous Sponges, the spicules, instead of being held together by *horny* material, are embraced by *siliceous* material, and thus the skeleton is rendered in their case perfectly rigid and glassy. In observing the development of the ova and embryos of Sponges, it was first noticed by Mr. H. J. Carter that the spicules are carried about by the general sarcode, and by it placed in position necessary for the building up of the skeleton structure, after which the cementing material is deposited about them. In the *Euplectellidæ* we have an instance in the Liverpool Museum of a vitreous Sponge, in which all the spicules necessary for the creation of that beautiful and symmetrical form which has been called the " Flower Basket of Venus," are placed in position ready for the vitreous material to be accumulated about them, but only here and there has it begun to be deposited. This interesting specimen, which was one of the first to be brought to this country, affords a good deal of information as to the way in which these beautiful forms are built up, and shews that what has been seen to take place in the fresh-water Sponge, and in the littoral Sponges of our own coasts, also takes place in these vitre-

ous Sponges, namely, that first the spicules are developed, and then they are placed in their positions necessary to form the skeleton structure, after which they become fixed by having accumulated about them the amorphous hardened material. This large specimen of *Dactylocalyx pumiceus* is the most perfect example hitherto seen; the small Sponge, which is a washed specimen, is in the condition of those in the British Museum, and is similar to them in size and form.

Halichondria virotulata.—The dark purple massive Sponge, to which this name has been given, is a new species. This species was first made known to us by Capt. J. A. Perry, who, a couple of years ago, brought over fragments of a Sponge which he had seen in the possession of Dr. Allen, of Jamaica; it was found to be new to science, and since then efforts have been made, but hitherto without success, to obtain a perfect example from that locality. The "Argo" specimens were obtained by Mr. Higgins at Puerto Cabello, on the coast of Caraccas, the southern side of the Caribbean Sea, and opposite to Jamaica. Most of these are of a massive spreading growth, but some take the form of groups of pyramidal prominences, whilst the Jamaica specimen is of a branched procumbent form. This Halichondroid Sponge has flesh spicules of the multihamate shape, each rotulate head having twelve hooks, and it is the first species of the family which has been found to possess them; but, since they were observed in it, Mr. H. J. Carter has noticed them in a deep-sea Sponge, dredged during the cruise of the "Porcupine," to which he has given the name *Halichondria Abyssii*.

Patuloscula procumbens.—This pretty yellow Sponge is an admirable specimen of a species of which several imperfect examples exist in the British Museum. It has received its generic and specific name from Mr. H. J. Carter, and will

be described by him in the third part of his *Notes on Spongida*, shortly to be published, which will be principally a catalogue of the British Museum Sponges. Mr. Higgins brought home two perfect specimens of slightly different growth, one of which has been presented to the British Museum, to be labelled "Argo Expedition," and the Liverpool Museum one will be the type specimen of the new species. I have already stated that the fibre of this Sponge is horny material, with a core of needle-shaped spicules.

Higginsia coralloides.—This very pretty coral-like Sponge from Grenada is of a new genus as well as species. In 1873, Mr. Higgins brought to the Museum, from Bantry Bay, a few Sponges obtained some twenty miles from Glengariff, one of which had a spicule complement differing from that of any known species, and, whilst he was away on the "Argo" cruise, some Sponges from Cape Palmas were presented by Mr. Keen, one of which was evidently of the same genus as the Irish Sponge. On sending the particulars to Mr. H. J. Carter, it was ascertained that several examples of the same genus, also from the Coast of Africa, existed in the British Museum. That gentleman advised that the genus should be at once named, and suggested that it should be called *Higginsia*, in compliment to the Rev. H. H. Higgins, the finder of the first species. Strange to say, shortly after, when the "Argo" had arrived, and her specimens had been unpacked, one of the prettiest Sponges in the collection proved to be a species of this new genus, and it has now been duly christened *Higginsia coralloides*.* It is one of the *Ectyonida*, the first family in Mr. Carter's order *Echinonemata*.

Luffaria (new species).—This amber-coloured Sponge is one of the genus *Luffaria*, of which there are several excellent specimens in the collection from various places. It

* See *Annals and Mag. Nat. Hist.*, 4th ser., vol. xix., p. 291.

will receive a specific name when the whole can be carefully examined, classified, and arranged.

The Rev. H. H. HIGGINS exhibited select specimens of Shells, Mosses, and Lichens from the Expedition, and made the following communication :—

ON LOWER CRYPTOGAMIC PLANTS, ETC., OF
THE ARGO EXPEDITION.

BY THE REV. H. H. HIGGINS, M.A.

The following notes on Lower Cryptogamic Plants, found in the island of Dominica, are selected from amongst many others, which may, I hope, when completed, appear in a collected form. *Hookeria aurea*, of Mitten. This beautiful moss grows in tufts to the height of three or four inches. When fresh the plant is of a pearly maize colour, varying to a pale straw colour, with a peculiar translucent appearance. Some of the stems and leaves are marked with sharply defined blotches of purplish crimson. In consequence of this peculiarity I sent specimens of the moss to Paris, for examination by M. Emille Bescherelle, of the Botanical Society of France, who has recently published a beautiful monograph of the mosses of the French Antilles. He identified it as *Hookeria aurea*. No one of the many authorities who have seen and described *H. aurea* has noticed the occurrence of colour patches, which I therefore regard as peculiar to specimens from Dominica, where it has not previously been found. In the classification adopted by Mr. Mitten, the plant is assigned to the genus *Hookeria*, but it seems probable that its natural affinities are with *Hypnum scorpioides*, *H. revolvens*, and *H. Lycopodioides*, natives of this country; all of which are mosses found in watery places, and are often deeply stained with purplish-crimson. The excessive moisture prevalent in Dominica has apparently

developed in *H. aurea*, elsewhere uniformly coloured, a character of peculiar staining, found also in its close allies. In the drier Antilles the distinctive colouring of the group is absent in *H. aurea*; in Dominica it is present. The circumstance is noticed as an instance of what may be termed a latent character, and as suggestive of the importance of characters derived from colour. I tested the coloured portions of the *Hookeria* and of *Hypnum revolvens* by the application of hydrate of potash, and came to the conclusion that the colouring matter in both plants was of a similar kind

The following is an extract from a very kind note which I received from M. Bescherelle:—

‘No. 2.—(*Ectropothecium*, tibi) est une espece d'*Hookeria*, très voisine de l'*Hookeria leiophylla* mihi, de la Martinique, et que je vous demande la permission de nommer *H. Higginsiana*. Elle fait partie d'une nouvelle section que j'ai nommée *Hookeridium*.'

Believing the moss to be new, I had proposed for it the name *Ectropothecium vernicosum*. It must now stand as *Hookeria* (*Hookeridium*) *Higginsiana*, Bescherelle. The following description by myself is, of course, provisional, awaiting the authentic description by the author of the species.

Hookeria (*Hookeridium*) *Higginsiana*, Bescherelle. *Dioica*; *caulis procumbens irregulariter sub-pinnatim ramosus*; *rami ascendentes*; *folia parum falcata, disticha, breviter binervia, lanceolato-acuminata, integerrima*; *capsula in pedunculo rubro nutans*; *dentibus peristomii pallidis*; *ciliis usque ad mediam coalitis*; *operculum recti-rostratum*.

Island of Dominica. Found abundantly in fruit, and growing in neat tufts; or clothing the surface of stones, and varying in colour from the lightest to the darkest shades of shell-lac.

A very beautiful little moss, much resembling some of the British species of *Campylopus*, occurred in tufts of moderate size rather plentifully in Dominica. The leaves were rigid and bristle-pointed, and the very short fronds,

shaped like a closed parasol, were delicately shaded from fawn colour to primrose. Most of the stems ended in long plumes like the seed-plume of the feather-grass, *Stipa pennata*. On examining my large bundle of dried mosses from Dominica, this plant was not to be found; but it soon became evident that the tufts had been broken up into single stems, and that these had travelled in all directions through the dried mosses, so that two stems were rarely found together.

This was evidently an instance of a natural locomotive contrivance designed for the distribution of the plant; as in the case of the seed popularly called the animated oat, which will work its way up one's sleeve, or, in its natural condition, will travel through dried stems of grass to a considerable distance. Contrivances for the distribution of seeds in the higher orders of plants are very numerous, and of the most varied character; but such contrivances have been much less frequently noticed amongst cryptogamic plants.

Many mosses with rigid bristle-pointed leaves are in the habit of shedding single stems, which often lie scattered on the surface of the tuft till the wind wafts them away; and when they fall amongst the dried stumps of grass, they are able to travel till they find a suitable resting-place. There are two very interesting points in the economy of these locomotive mosses. Some of them very rarely produce capsules, as in some species of *Campylopus*; and being thus without spores, they are entirely dependent on their locomotive appliances for the distribution of their species. Others bear capsules on footstalks, curved like the neck of a swan, as in some species of *Campylopus* and *Grimmia*, so that the spore-case sheds its spores on the plant itself, which, being capable of motion, bears away the spores to a spot suitable for germinating. Other mosses have erect footstalks, which hold up the capsule for the spores to be disseminated by the wind.

M. Bescherelle determined the Campylopus-like moss from Dominica as *Neckera trichophylla*. I was unable to send him fruiting specimens, not having found any ; but his authority is quite sufficient, and the name confers a great additional interest on the plant, the *Pleurocarpus Nekereæ* being so far removed from the other locomotive mosses, which belong to the acrocarpus division.

Upon the subject of the passage of plants across the Atlantic, the following remarks may be interesting:—

Professor Unger arrived at the conclusion, that in Tertiary times there was a passage of plants from America to Europe. A plant found by myself last year in the Island of Dominica, West Indies, led me to think it probable that there had been an extension of at least one plant in the opposite direction. The plant to which I refer is one of the Hepaticæ, *Haplomitrium Hookeri* of Lyell. It differs so much from other Hepaticæ that I was able approximately to identify it on the spot, where I found it in considerable abundance. Should it prove to be specifically distinct, my remarks may still, to some extent, hold good. It was growing in a dark, moist, shady spot on the north side of a mountain, at an elevation of about 4000 feet. *H. Hookeri* is generally distributed over the North of Europe, but I cannot find that it has ever before been found out of Europe. Dr. Oliver kindly informs me that there are only European specimens in the Herbarium at Kew. I have failed in obtaining information of its occurrence either in North or South America, or in the intermediate islands. Nees ab Esenbeck, in his *Synopsis Hepaticarum*, whilst recording a large number of Hepaticæ from the West Indies, mentions *H. Hookeri* only from Europe. Now it is by no means an inconspicuous plant, and it seems altogether unlikely to have been overlooked by such careful observers as Swartz and others, who

have studied the Hepaticæ of the West Indies. Hence I draw the following inferences, to which may be attached a greater or a less amount of probability. 1. That the biological centre for *H. Hookeri* is Northern Europe. 2. That it has thence crossed the Atlantic in a rather narrow zone. 3. That it did not reach the Continent of America. This, of course, is subject to correction; it may have been found there. From the great extent of territory and variety of climate on the mainland, I think if it had ever reached America it would still be found there. 4. That it may have reached the West Indies, and have died out from Cuba, Jamaica, and other islands, through the prevalence of dry seasons, before the lower Cryptogamic plants were studied by competent botanists. 5. That it has remained in Dominica because of the altogether peculiar moisture of the climate in that island. 6. That it has not hitherto been found in Dominica because, from some reason unknown to myself, botanists seem to have neglected this *true* pearl of the Antilles, matchless in the beauty of its natural scenery and in the wealth of its Cryptogamic flora.

H. Hookeri is noticed as peculiar in not recovering its freshness when moistened after having been dried. This I found to be the case. On being carefully moistened about eight months after it was collected and dried, it remained flaccid, whilst the rest of the mosses and Hepaticæ from Dominica, when similarly treated, looked as fresh as when they were gathered. But *H. Hookeri* exhibited another peculiarity even more remarkable, for it alone of all the Muscinæ that I brought home, grew and produced fruit after so long a period of desiccation. The fruiting parts of a specimen which I sent to the Herbarium at Kew were entirely developed in a moist case on the table at which I am now writing. It seems as if the plant, incapable of the imbibition or intus-susception of moisture sufficient to restore the freshness of

its foliage, nevertheless retained, in a very unusual degree, its capacity for such development as might secure the continuance of its species. Such a peculiarity no doubt favours the suggestion that *H. Hookeri* may have crossed from the East. I found many mosses in Madeira, and several lichens in Jamaica, which I have been quite unable to distinguish from British species; these may be common cases of widely distributed forms. *H. Hookeri* does not appear to be of this class.

This little plant is the subject of a most elaborate memoir in *Nova Acta*, vol. xxii., part 1, by Dr. Gottsche, occupying 120 closely-printed quarto pages, and illustrated by 8 plates. He does not, I believe, mention its occurrence out of Europe.

SUMMARY OF THE FISHES OF THE ARGO EXPEDITION.

By THOMAS J. MOORE.

The following is an approximate summary of the Fishes obtained during the voyage:—

	Species.	Specimens.
Madeira - - - -	20	32
Crossing the Atlantic - -	2	9
Antigua - - - -	5	9
St. Vincent - - - -	8	16
Grenada - - - -	8	20
Trinidad - - - -	13	40
Gulf of Paria - - - -	3	8
Santa Marta - - - -	4	21
Nassau - - - -	19	68
	—	—
	<u>82</u>	<u>223</u>

SECOND ORDINARY MEETING.

ROYAL INSTITUTION, October 30th, 1876.

J. A. PICTON, F.S.A., PRESIDENT, in the Chair.

Messrs. Richard Bulman, M'Grath, M.D., J. H. Johnson, F.G.S., J. H. Nickson, and A. Weightman were elected Ordinary Members.

The return of the Arctic Expedition gave rise to a discussion on the discovery of Fossil Corals and Coal at Disco Island, as proofs of the Arctic Regions having at some former period been under a warmer climate.

Mr. T. J. MOORE exhibited a collection of Arms and Weapons taken at the Siege of Moulton in 1849, kindly lent for the purpose by Major-General Bellasis.

Dr. WHITTLE exhibited a specimen of Manganese, and Mr. STEARN a specimen of Gallium, the new element discovered by M. Lecoq de Boisbaudran, in August, 1865.

The Rev. T. P. KIRKMAN, M.A., F.R.S., then read a Paper on "How we come to know."*

Ladies were present at this Meeting.

THIRD ORDINARY MEETING.

ROYAL INSTITUTION, November 13th, 1876.

J. A. PICTON, F.S.A., PRESIDENT, in the Chair.

Messrs. G. H. Ball, T. E. Stephens, E. W. Yates, and T. Carson, M.D., were elected Ordinary Members.

* See Page 303.

A communication was received from the Council recommending the alteration of the twenty-second law, so as to abridge the term of the Presidential Office to two years. The matter was referred to an Extraordinary Meeting, to be held on the 27th of November.

Mr. T. J. MOORE exhibited two specimens of Isopod Crustaceans (*Cymothoæ*), attached within the under jaw of a fish from Jamaica, collected by Capt. Perry, Associate of the Society, who made some remarks thereon.

Mr. WOOD exhibited two works on the British Marine Algæ, by Mr. Gratton, of Torquay.

Mr. A. J. MOTT then read a Paper on "Hæckel's History of Creation."*

Ladies were present at this Meeting.

FOURTH ORDINARY MEETING.

ROYAL INSTITUTION, November 27th, 1876.

J. A. PICTON, F.S.A., PRESIDENT, in the Chair.

The President exhibited photographs of the title-pages of two of the earliest books printed in Liverpool, namely, "*Hymns Sacred to the Lord's Table*, collected and methodised by Charles Owen, Leverpool. Printed by S. Terry for Daniel Birchall, 1712;" and "*The Prospect of Heaven, the Support of Afflicted Christians*, consider'd and improv'd in a Funeral Sermon at St. Hellen's Chappel (some time ago) upon the death of Edward Potter of Rainhill, a Young Man who died beyond Sea. By the late Reverend Mr. James Naylor. And now upon the Request of the Deceas'd's Father, Prefac'd and Published by Charles Owen. Printed at Leverpool for Daniel Birchall in Castle St. in 1713."

* See Page 41.

Mr. A. HIGGINSON read an extract from a letter received from a lady in Berlin (19th November, 1876), describing the present condition of the young Gorilla which was lately landed at Liverpool and conveyed to the Prussian capital.

Dr. NEVINS then read a Paper on "Some Phases of Modern French Thought."*

Ladies were present at this Meeting.

Previous to the above ordinary business, an EXTRAORDINARY MEETING was held, the President in the Chair, to consider for the first time the following alteration of the twenty-second law:—

"That the President shall be elected by the Society at the last Meeting of every *alternate Session* (instead of *Third Session*). His term of office shall be *two* (not *three*) years, commencing at the Annual Meeting following his election."

The alteration was proposed by the President, who explained the circumstances which he considered rendered it desirable to make the change. The Honorary Secretary seconded the motion, and it was carried by a large majority.

It was then proposed by Mr. UNWIN, seconded by Mr. YATES, and agreed to, "That at the next Extraordinary Meeting the Society should take into its consideration the advisability of meeting at half-past six, instead of seven o'clock, as prescribed by Law 45."

FIFTH ORDINARY MEETING.

ROYAL INSTITUTION, December 11th, 1876.

J. A. PICTON, F.S.A., PRESIDENT, in the Chair.

Mr. Richard Roberts and the Rev. Lorenzo Torpy, M.A., were elected Ordinary Members.

* See Page 123.

The President exhibited a copy of "*Britain's Remembrancer, &c.*," published by Bryan Blundell, Esq., and sold for the benefit of the Blue Coat Hospital, in Liverpool, 1755."

Mr. LEWIS HUGHES exhibited and explained the construction of Browning's Akribetic Galvanometer on Ridout's Patent.

Mr. T. J. MOORE exhibited a Diamond *in situ*, in "Maiden Blue," lately presented to the Museum by Mr. J. Vernon Hope, from the Kimberley Mine, Griqualand West, South Africa, who briefly described the methods of mining there practised.

Mr. CHANTRELL gave the following analysis of the "Maiden Blue," as determined by his son, Mr. H. W. Chantrell.

ANALYSIS OF "MAIDEN BLUE."

Silicic acid	40.62
Oxide of alumina	21.98
Water	10.15
Insoluble in everything (sand, grit, &c.)	8.94
Magnesia	7.20
Oxide of iron	5.89
Organic matter	4.56
Lime	1.50
Phosphoric acid89
Sulphurous acid15
	<hr/>
	101.28
	<hr/>

Chiefly silicate of magnesia, iron, and alumina, with traces of sulphate and phosphate of lime.

Mr. STEARN exhibited two new forms of the Sprengel Pump, with single and double fall tubes, and by means of the cessation of an induction current in a vacuum tube, and

the increase in speed of rotation in a Radiometer, illustrated the perfection of the exhaustion produced by the apparatus.

Mr. JOSIAH MARPLES then read a Paper on "Type Founders and Type Founding."*

Ladies were present at this Meeting.

AN EXTRAORDINARY MEETING was held the same evening, the PRESIDENT in the Chair, when the change in Law 22, as proposed at the previous meeting, was finally carried.

The following resolution, proposed by Mr. UNWIN, and seconded by Dr. NEVINS, was also carried for the first time:—

"That the business of each Ordinary Meeting shall commence at *Half-past Six* (instead of *Seven*) o'clock, provided the Society be duly constituted at that time." Law 45.

SIXTH ORDINARY MEETING.

ROYAL INSTITUTION, 8th January, 1877.

J. A. PICTON, F.S.A., PRESIDENT, in the Chair.

Mr. James Ogston was elected an Ordinary Member.

Mr. JOHN MILLER exhibited a copy of an Autotype reproduction of John Milton's "Common Place Book," the original of which was in the possession of Sir Frederick Graham.

Mr. J. L. PALMER, F.S.A., F.R.G.S., Fleet Surgeon R.N., read a Paper on "The Marquesans—their History, Traditions, and Customs."†

Ladies were present at this meeting.

AN EXTRAORDINARY MEETING was held the same evening to consider, for the second time, the proposed alteration in Law 45.

* See Page 147.

† See page 271.

After some discussion, the proposition, on being put, was lost by a large majority.

SEVENTH ORDINARY MEETING.

ROYAL INSTITUTION, 22nd January, 1877.

J. A. PICTON, F.S.A., PRESIDENT, in the Chair.

The PRESIDENT drew the attention of the Meeting to an article in the current number of the *Quarterly Review*, on "The Geographical Results of the Arctic Expedition," with special reference to the causes therein assigned for the existence of fossil tropical plants in the Polar Regions.

The remainder of the evening was devoted to the discussion of Mr. Mott's Paper on "Haeckel's History of Creation."*

Ladies were present at the meeting.

EIGHTH ORDINARY MEETING.

ROYAL INSTITUTION, 5th February, 1877.

ALFRED HIGGINSON, M.R.C.S., VICE-PRESIDENT, AND EDWARD R. RUSSELL successively occupied the Chair.

Mr. CHANTRELL exhibited the "Patent Electric Pen," and distributed specimens of writing produced by it.

A communication was received from the Council recom-

* See page 91.

mending the election of Professor F. V. Hayden, M.D., United States Geological and Geographical Survey, as an Honorary Member, and of Mr. Arthur B. Nevins as an Associate.

Mr. JOSEPH BOULT then read a Paper "On the Suffix -ster."*

NINTH ORDINARY MEETING.

ROYAL INSTITUTION, 19th February, 1877.

ALFRED HIGGINSON, M.R.C.S., VICE-PRESIDENT,
in the Chair.

Professor F. V. Hayden, M.D., Director of the United States Geological and Geographical Survey, was elected an Honorary Member, and Mr. Arthur B. Nevins an Associate.

Messrs. Douglas R. Samuel, T. D. Rich, John Wallace, M.D., W. Marples, R. P. Thacker, and the Rev. Henry Gardiner were also elected Ordinary Members.

Mr. J. L. PALMER, R.N., F.S.A., etc., read the following extracts from a letter written by Mr. John Adams, of Pitcairn's Island, giving an account of a supposed Sea Serpent, as seen by him and a boat's crew off that island:—

[EXTRACT.]

Letter from JOHN ADAMS, Grandson of JOHN ADAMS, Quartermaster of
H.M.S. "Bounty," off Pitcairn Island.

"Norfolk Island, January 7th, 1874.

* * * *

"About the Sea Serpent seen off here, I give it you as it really was. But I must first tell you, that in whaling it here we generally go under

* See page 245.

sail, when no whales are seen, keeping a good look-out as we sail along; the boat-steerer, as the person is called whose place it is to strike the whale, standing up in the bows of the boat, looking out a-head and all round. Well then, on the 15th October, 1870, wind S.E. and light, our boat being a mile off Nepean Island, and on the port tack, our look-out reported a calf (as the young whale is called) about a mile and a half distant on the lee bow. We accordingly kept off, and when about one hundred yards from the supposed calf, he said—'I cannot make out what it is; I have not seen a spout yet; but there is an animal of some sort, for his back is out of the water, and there is a wash there all the time.' 'Very well,' was the answer; 'keep a sharp look out.' On we went till within a few yards of the object, when the look-out exclaimed—'Look! it is a Sea Serpent!' And look we did. The boat shot within a yard of it, and there it was, a veritable Sea Serpent. Let Professor Owen, or any Professor of Natural History, say that such a thing as a Sea Serpent could not exist, but there, before our eyes, and within a foot or so of us, lay a thing, a living confutation of their theory. When first seen, I suppose it must have been asleep, for its head was lying flat on the surface of the sea, and its body coiled up. The tail of the monster I saw plainly, hanging some three or four fathoms below the surface. When we came near it, the beast, if I may call it so, raised its head out of the water, looked at us, then slowly straightening himself, he very leisurely moved off. I cannot tell you with any certainty the length of it, for it was not lying with its whole length on the surface, but, as nearly as I could judge, it must have been thirty or forty feet. It is of a reddish colour, and about a foot or eighteen inches in diameter. We have been about the Island in boats almost every day when the weather is fine for nearly eighteen years, and have never seen anything like it before or since then." * * * *

On the motion of Mr. JOSIAH MARPLES, seconded by the HONORARY SECRETARY, it was unanimously resolved to hold the Twelfth Meeting of the Society on the 9th of April, in consequence of the regular date falling on Easter Monday.

Mr. E. DAVIES, F.C.S., then read a Paper on "Popular Errors about Poisons."*

Ladies were present at the meeting.

* See page 229.

TENTH ORDINARY MEETING.

ROYAL INSTITUTION, 5th March, 1877.

J. A. PICTON, F.S.A., PRESIDENT, in the Chair.

Mr. JOSEPH MARPLES exhibited an apparatus for drawing Lissajous' Curves, on a simpler plan than that constructed by Messrs. Tisley and Spiller.

The Rev. T. P. KIRKMAN, M.A., F.R.S., then read a Paper on "The First Definition of the Scholastic Philosophy."*

ELEVENTH ORDINARY MEETING.

ROYAL INSTITUTION, 19th March, 1877.

J. A. PICTON, F.S.A., PRESIDENT, in the Chair.

Mr. T. F. Parry and the Rev. H. I. Johnson, M.A., were elected Ordinary Members.

Mr. T. J. MOORE exhibited selections from a collection of specimens, chiefly marine, made by Capt. W. H. Cawne Warren, Associate of the Society, on a voyage to Australia, the Pacific Islands, and San Francisco.

Capt. CAWNE WARREN was present at the meeting, and gave various particulars as to the specimens before the Society.

The *Algæ*, *Zoophytes*, and *Polyzoa* having been submitted to Miss GATTY for examination, that lady, who has inherited her mother's well-known love for these beautiful objects, has kindly arranged and named the specimens:—

* See page 317.

LIST OF ALGÆ, HYDROZOA, AND POLYZOA, FROM PORTLAND BAY, VICTORIA, AUSTRALIA, COLLECTED BY CAPT. W. H. CAWNE WARREN, ASSOCIATE, AND NAMED BY MISS HORATIA K. F. GATTY.

ALGÆ.

MELANOSPERMEÆ.

FAMILY.	SPECIES.
FUCACEÆ	<i>Scaberia Agardhii.</i>
SPOROCHNACEÆ . .	<i>Carpomitra inermis.</i>
	" <i>caudata.</i>
DICTYOTACEÆ . . .	<i>Dictyota paniculata.</i>
	" <i>furcellata?</i>
	<i>Lobospira bicuspidata.</i>
	<i>Zonaria Turneri.</i>
ECTOCARPACEÆ . .	<i>Sphacelaria paniculata.</i>
	RHODOSPERMEÆ.
RHODOMELACEÆ . .	<i>Polysiphonia hystrix.</i>
	" <i>cancellata.</i>
	<i>Thuretia quercifolia.</i>
LAURENCIACEÆ . .	<i>Delisia pulchra.</i>
	<i>Laurencia thuyoidea?</i>
CORALLINACEÆ . . .	<i>Amphiroa granifera.</i>
	" <i>stelligera.</i>
	<i>Corallina rosea</i> (Agardh).
	" <i>officinalis.</i>
	" <i>Cuxieri.</i>
	" " <i>var. crispata.</i>
	<i>Melobesia patena.</i>
SPHÆROCOCOIDEÆ .	<i>Melanthalia abscissa.</i>
	" <i>obtusata.</i>
	<i>Phacelocarpus Labillardieri.</i>
GELIDIACEÆ	<i>Gelidium glandulæfolium.</i>
	<i>Hypnea episcopalis.</i>
	<i>Pterocladia lucida.</i>

- RHODYMENIACEÆ . *Plocamium procerum*.
 " " *var. Mertensi?*
 " *costatum?*
 " *coccineum*.
 " *angustum*.
 CRYPTONEMIACEÆ . *Callophyllis Lamberti*.
Chylocladia clavellosa.
 CERAMIACEÆ . . . *Ballia callitricha*.
Crouania vestita.
Dasyphila Preissii.
Haloplegma Preissii.
Ptilota rhodocallis.
 " *Jeannerettii*.
 " *articulata*.

HYDROZOA.

- Sertularia elongata?* . . Lamouroux.
 " *scandens?* . . Lamouroux.

POLYZOA.

SUB-ORDER I.—CHEILOSTOMATA.

FAMILY.

SPECIES.

- CATENICELLIDÆ . . *Catenicella margaritacea*.
 " *hastata*.
 " *cribaria*.
 " *perforata*.
 " *formosa*.
 " *lorica*.
 " *aurita*.
 " *plagiostoma*.
 " *ventricosa*.
 " *ringens*.
 " *elegans*.
 " (2 species undetermined.*)

- SALICORNARIADÆ** . . *Salicornaria gracilis.*
Onchopora hirsuta.
 " *tubulosa.*
- CELLULARIADÆ** . . *Cellularia cuspidata.*
Scrupocellaria cervicornis.
 " *cyclostoma.*
 " (undetermined.*)
Canda arachnoides.
Emma crystallina.
 " *tricellata?*
- GEMELLARIADÆ** . . *Dimetopia spicata.*
- CABEREADEÆ** . . . *Caberea Boryi.*
- BICELLARIADÆ** . . *Bicellaria tuba.*
- FLUSTRADÆ** . . . *Carbasa dissimilis.*
- MEMBRANIPORIDÆ** . *Membranipora membranacea.*
 " *cervicornis.*
 " *pilosa.*
 " *stenostoma.*
 " *lineata.*
 " (2 species undetermined.*)
Lepralia hyalina.
- CELLEPORIDÆ** . . . *Cellepora* (2 species undetermined.*)

SUB-ORDER II.—CYCLOSTOMATA.

- TUBULIPORIDÆ** . . *Tubulipora* (undetermined.*)

SUB-ORDER III.—CTENOSTOMATA.

- VESICULARIDÆ** . . *Amathia polycystica.*
 " *cornuta.*

Mr. MOORE then brought forward various specimens collected and presented to the Museum by Capt. Slack, Associate of the Society, and drew attention, among the Fishes, to several examples, from Rio Janeiro, of the lowest

* The undetermined species noted above, and one other, have been sent to Mr. Busk for further examination.

known form of all vertebrates, that of the Lancelet, *Amphioxus lanceolatus*; and, among the Radiates, to two fine specimens of *Encope* from the same locality. The *Algæ* and *Polyzoa* are enumerated in the following list:—

LIST OF ALGÆ AND POLYZOA COLLECTED IN 1876, BY CAPT. SLACK, ASSOCIATE, AND NAMED BY MISS HORATIA K. F. GATTY.

ALGÆ.

RHODOSPERMÆ.

FAMILY.	SPECIES.	
CORALLINACEÆ . . .	<i>Melobesia mamillaris.</i>	St. Vincent, Cape de Verdes.
	" <i>fasciculata</i>	"
	<i>Jania corniculata</i>	"
HELMINTHOCLEADÆ	<i>Galaxaura lapidescens</i>	"
SQUAMARIÆ . . .	<i>Peysonnelia atro-purpurea</i>	"

POLYZOA.

SCRUPARIADÆ . . .	<i>Ætea anguina.</i>	Rio Janeiro.
BICELLARIADÆ . . .	<i>Bugula neritina.</i>	"
MEMBRANIPORIDÆ . . .	<i>Membranipora Lacroixii.</i>	St. Vincent, Cape de Verdes.
	" <i>calpensis.</i>	Gibraltar Bay.
	<i>Lepralia coccinea.</i>	"
	" <i>ciliata.</i>	"
	" <i>cucullata.</i>	St. Vincent.
	" <i>trispinosa.</i>	"
CELLEPORIDÆ . . .	<i>Cellepora bispinosa.</i>	Rio Janeiro.
	" <i>ramulosa.</i>	Gibraltar Bay.
	" (undescribed ?)	
	" ———	
ESCHARIDÆ . . .	<i>Eschara fuegensis.</i>	Rio Janeiro.

Mr. MOORE also exhibited an extensive series of Marine Organisms, mostly minute, obtained by surface dredging by Capt. J. H. Mortimer, Senior Associate of the Society. They were chiefly comprised in small glass vessels of the kind used by Homœopathists; and were collected in the Atlantic and Pacific when voyaging between New York and San Francisco in 1875-6. This collection was rich in surface Mollusca, especially in Pteropods.

In addition to these small objects, there were various specimens of *Phyllosoma*, *Velella*, *Porpita*, *Calycophoridae*, *Salpæ*, &c., several being mounted and displayed with great care and success; also small jelly-like masses, considered by Capt. Mortimer to be composed of *Collophæra* and other *Thalassicolida*.

The stinging properties of the *Physalia*, or Portuguese Man of War, have long been a favourite study with Capt. Mortimer, who on this subject had made the following notes, and has preserved portions of tentacle for further use with the microscope.

NOTES ON PHYSALIA, BY CAPT. J. H. MORTIMER, ASSOCIATE,
WITH REMARKS BY MR. W. J. SOLLAS, F.G.S., &c.

April 20th, 1876.—South Atlantic (2° So. 29.30 West). Caught a large *Physalia*, and was stung very badly by a piece of tentacle coming in contact with the skin between my fingers. To determine whether the effect would be the same on different persons, I tried it, with their consent, on the first and second officers, the carpenter, and the boy. The effect was alike in each, except that the amount of pain corresponded to the tenderness of the skin where applied, and that the boy was affected more than the men.

One piece of the tentacle that had been detached from the animal, and had been on the bottom of the basin for some thirty minutes, had not lost its power of contracting and

expanding, and when laid on the side of my finger, as being the tenderest part, in a few moments attached itself to the skin with a tenacity surprising in a detached fragment. One would have supposed it would have lost its vitality, but its fire was all there, and upon examining with the microscope the multitude of thread-cells which serve to attach it to any object it may desire to fasten to.

Subsequently, I noticed the note of Prof. Leidy appended to an article on *Physalia* in Dr. Harrison Allen's "Outlines of Comparative Anatomy," published at Philadelphia in 1874, and at my next opportunity again observed closely. I had caught a good-sized and brilliant rose-coloured *Physalia*. The whole of the tentacles were full of life, and contracted and expanded with a constant motion. I tried in different ways to preserve pieces of the tentacle on glass slides for mounting, but, as before, without success. The thread or tentacle would dry enough to adhere to the glass, but its contractile force would break it, and the whole length would resolve itself into a lump. At last I took a tentacle, and, without severing it from the animal, laid it over the edge of a basin and across the glass side, which was fixed on the stage of the microscope. Holding the end, and so viewing it under a half-inch power, I was at length rewarded by viewing, first the granules separating from the tentacles, and then suddenly myriads of cells apparently burst, the lasso threads (well-named) spreading in every direction, and forming a silvery frost-work on either side of the extended tentacle. Most of the threads, where the whole length could be seen, seemed still attached to the emptied capsules.

[The above notes, accompanied with specimens, having been placed in the hands of Mr. W. J. Sollas, during his sojourn in Liverpool as Cambridge Lecturer on Biology, and who is specially devoted to the study of these lower forms, he has kindly written the following remarks on Capt. Mortimer's

researches. These researches fully deserve all the encomiums passed upon them by Mr. Sollas, when it is borne in mind that they were made by Capt. Mortimer while discharging all the active duties of his profession. They also show how much may be done by a willing worker, notwithstanding the discomforts, inconveniences and interruptions daily attending life at sea, even under the most favourable conditions of a well-found and commodious sailing ship. T.J.M.]

9, Barton Terrace, Dawlish,

April 3rd, 1877.

My Dear Mr. MOORE,

I have carefully read Capt. Mortimer's very interesting account of his observations on the tentacles and thread-cells of *Physalia atriculus*. They have evidently been very carefully and accurately made, and receive striking confirmation by anticipation at the hands of Professor Huxley, whose drawings and descriptions agree in a very remarkable manner with those of Capt. Mortimer. On plate X. of Huxley's *Oceanic Hydrozoa*, published by the Ray Society, a drawing is given of the whole tentacles (fig. 11), and magnified (fig. 12), to shew the reniform enlargements which are so conspicuous in Capt. Mortimer's mounted specimens; the thread-cells are given in fig. 12, *a* & *b*, charged and discharged, as also they appear in Capt. Mortimer's slide. The substance of the description given in the *Oceanic Hydrozoa*, is, that the tentacle is a "delicate narrow ribbon, composed of two layers (inner-skin, or *endoderm*, and outer-skin, or *ectoderm*); having transverse reniform thickenings at regular intervals (fig. 12). The substance of each thickening has a dark-blue colour and embedded within it are myriads of close-set, colorless, spherical thread cells."

I am very much obliged for the opportunity which has been afforded me of examining these difficultly-obtained structures, and I hope you will allow me to express a wish that Capt. Mortimer may continue to favour us with an account of observations which he is able to make at sea, and which are all the more valuable for being obtained from the fresh specimens as soon as they are caught, and by an observer who is evidently as acute as he is painstaking.

Believe me,

Very faithfully yours,

W. J. SOLLAS.

The Rev. H. H. HIGGINS, M.A., warmly applauded the services rendered to Zoological Science by the Associates of the Society, the specimens exhibited from them, from time to time, being such as would be eagerly welcomed by any of the learned societies in London. He suggested that, by means of suitable drawings and descriptions in the Society's Volume of *Proceedings*, these specimens should be brought more prominently before the Society and the public.

Mr. G. H. MORTON, F.G.S., then read a Paper on "The Introduction of Geological Maps,"* and was followed by Dr. NEVINS, who read a Paper "On the Translation of Συνήμι and its Forms, and of ἵνα μή with a Subjunctive Mood, in the Authorised Version of the New Testament."†

TWELFTH ORDINARY MEETING.

ROYAL INSTITUTION, April 9th, 1877.

J. A. PICTON, F.S.A., PRESIDENT, in the Chair.

M. R. B. Hooper was elected an Ordinary Member.

The President exhibited a printed copy of the Roll of the Liverpool Volunteers in 1797, Thomas Earle, Captain, and read some amusing extracts from the rules and regulations of the Company.

Mr. ALFRED HIGGINSON exhibited and presented to the Society a copy of a Discourse delivered by William Roscoe on the opening of the Royal Institution, 25th November, 1817. The title of the discourse was "On the Origin and Vicissitudes of Literature, Science, and Art, and their Influence on the Present State of Society." Liverpool, 1817.

Mr. ABBOTT, B.A., proposed the question: "What part

* See Page 293. † See Page 167.

of the globe first registers a new day?" which gave rise to some discussion.

Mr. ALFRED MORGAN, Honorary Librarian, communicated a note respecting the "Origin and Progress of the United States Geological and Geographical Survey of the Territories."*

Mr. MALCOLM GUTHRIE then read a Paper on "The Causational Theory of Volition—a Reply to Strictures in Dr. Carpenter's Mental Physiology."

THIRTEENTH ORDINARY MEETING.

ROYAL INSTITUTION, 16th April, 1877.

J. A. PICTON, F.S.A., PRESIDENT, in the Chair.

Ladies were present at this meeting.

A discussion was held on miscellaneous topics, among others, on the alleged existence of an Intra Mercurial Planet; on the question propounded by Mr. Abbott at the last meeting and on the co-operative constitution of Sir Joseph Whitworth's Engineering Works.

The Rev. H. H. HIGGINS submitted the Manuscript of "Liverpool Museum Report No. 1," devoted exclusively to the Mollusca of the Argo Expedition to the West Indies, 1876, as worked out by himself and Mr. F. P. Marrat.†

Mr. E. R. RUSSELL then read a Paper on "The Autobiography and Memorials of Miss Martineau."‡

FOURTEENTH ORDINARY MEETING.

ROYAL INSTITUTION, 30th April, 1877.

J. A. PICTON, F.S.A., PRESIDENT, in the Chair.

The PRESIDENT formally tendered his resignation, which was accepted by the Society, on the motion of the Rev. H. H.

* See Page 357.

† See Page 405.

‡ See page 185.

HIGGINS, M.A., seconded by Mr. R. C. JOHNSON, F.R.A.S.,
Hon. Treasurer.

The Rev. H. H. HIGGINS then moved "that Dr. Drysdale, one of the Vice-Presidents, be elected President for the ensuing term of two years."

The motion was seconded by Mr. B. L. BENAS, and carried unanimously.

NOTES ON LEPIDOPTEROUS COCOONS AND LARVA CASES FROM
SÃO PAULO, BRAZIL. BY MR. E. DUKINFIELD JONES, C.E.
WITH A PLATE.

Mr. T. J. MOORE brought before the Society some interesting examples of Insect-Metamorphoses, recently brought from São Paulo, one of the southern provinces of Brazil, by Mr. E. Dukinfield Jones, who was present, and which that gentleman had kindly given to the Museum. Among them were several cocoons, probably of a species of Moth belonging to the family *Bombycidae*. These were of hard texture and various colour, one being grey and the others yellow or brown. They measure in greatest length 2 inches, and $\frac{3}{8}$ in greatest diameter.

Mr. Jones had furnished a drawing, showing the mode of suspension of these cocoons,* accompanied by the following note :—

"While in the larva state, the insect attaches the case temporarily by threads to the twigs of the tree on which it feeds. The threads are somewhat loosely fixed, so as to allow of considerable movement of the case. When the larva has eaten all the leaves thus within its reach, it loosens the threads and moves to another place. Before changing to the pupa state, the case is fixed permanently with silk and mucus to a twig."

Beside the above, there were also larva-cases of three

* See accompanying Plate.



E. O. JONES DEL.

species, apparently belonging to *Oiketicus*, a genus of Moths found in various parts of the world, in which the females are entirely wingless. The largest case measures 5 inches in length, and $1\frac{1}{4}$ inch in diameter. It contains a number of pieces of twigs, three-fourths of an inch and more in length, worked up into and forming a silken tubular bag, covered with an unbroken surface of finely-spun silk, of a brown colour.

Mr. Jones has supplied the following history of this large specimen :—

OIKETICUS.

This specimen was found between São Paulo and Jacareby, in the province of São Paulo. The Caterpillar was very lively, and was constantly crawling about with great activity, protruding its head, and then drawing the case up after it in the manner of the Caddis-worm, which it much resembles in its movements.

On one occasion it crawled up the smooth surface of a looking-glass, without losing or emerging from its case, spinning a ladder of silk, which adhered firmly to the glass.

I placed it on a small tree in my garden, where it remained for two or three months stationary, having firmly attached itself to a twig by silk and mucilage, which entirely closed the anterior aperture of the case.

I brought the specimen to England, in July, and upon arrival, found the pupa had come out of the case. Keeping this in a warm place, the perfect wingless grub-like insect came out in September, and is now in the Free Museum.*

Mr. ALFRED MORGAN, Hon. Librarian, read a Paper on "The Cliff Houses and Antiquities of Colorado and New Mexico," † and was followed by the HON. SECRETARY, who read a Paper by Mr. REDISH on "The Silver Question." ‡

*An able paper by Prof. Westwood, describing and figuring several species of this remarkable genus of Lepidopterous Insects, will be found in the *Proceedings of the Zoological Society of London*, for 1854, pp. 219-243. Plates, *Annulosa*, xxxiv.-xxxvii.

† See page 348. ‡ See page 867.

PAPERS READ DURING SESSION.

OPENING ADDRESS.

By JAMES A. PICTON, F.S.A.

IN the Address which I had the honour of delivering at the opening of last Session, I ventured to bring under notice the direction and tendency of the complicated interaction of circumstances, motives, and principles which are constantly operating, with varied results, in the current of human affairs; or, in other words, "the tendencies and future of modern civilisation."

The subject of human progress, in all its bearings, is a fruitful and never-ending theme. The present, however important and pregnant with results, can only occupy a limited portion of our thoughts. Reflection on the past, and speculation on the future, will ever form the most powerful motives to human action. According to the words of one of our great moralists:—"Whatever abstracts our minds from the present, and carries them into the distant past, or the remote future, advances us in the scale of thinking beings."

On the present occasion I wish to penetrate, in a certain direction, into the mystery and darkness in which the earliest period of the human race will ever be shrouded. In doing so, it is not my intention to trespass on the ground which has already been so ably occupied by my predecessor in several of his presidential addresses. There are various aspects in which the dawn of human progress may be contemplated, and various sources of information applicable to these points of view. Written records soon fail us. Tradition and mythology supply a copious flood of archaic utterances, which must remain mysterious, vague, and uncertain,

until some modern Œdipus shall arise to solve the riddle of the Sphynx.

Amongst the visible remains of the works of man's brain and hands we tread with more confidence. We can pass beyond the historical period; and, travelling back through the mighty remains of Egypt and Assyria, Baalbec and Palmyra, we can speculate on the relics brought to light of ancient Troy. The lake dwellings afford a still more primitive aspect of human society. The cromlechs, the barrows, the stone circles, the various sepulchral remains, all contribute their information as to the habits and condition of those who constructed them. Still further back, we arrive at the cave dwellings of a period when man struggled for existence with the mammoth, the hyæna, and the cave bear, until, finally, we arrive at the palæolithic fragments of the valley of the Somme, where the earliest indications of the human race seem to be identified with the glacial period in the geological series.

On this aspect of the problem I am not about to enlarge. It has been ably treated by many eminent writers, such as Sir John Lubbock,¹ Mr. Tylor,² Dr. Evans,³ Dr. Daniel Wilson,⁴ Mr. Llewellyn Jewitt,⁵ and others.

However interesting this study may be, and useful in throwing light on the early condition and progress of the human race, the element of continuity is wanting, the thread of connexion is hopelessly broken. It is almost startling to find that the Kasia tribes in Hindostan are still constructing cromlechs, stone circles, and maenhirs, which it would be difficult to distinguish from those of Wales, Cornwall, or

¹ *Origin of Civilisation*. London, 1870. *Prehistoric Times*. London, 1865.

² *Researches into the Early History of Mankind*. London, 1865.

³ *Ancient Stone Implements, etc.* London, 1872.

⁴ *Prehistoric Man*. London, 2 vols, 1862.

⁵ *Cave Mounds*. London, 1870.

Brittany ; and that lake dwellings, such as those to which in Europe we ascribe a very remote antiquity, are still the ordinary habitations of the Dyaks in the far east, and of certain tribes in Central Africa. We are entirely ignorant whether these modes of construction have descended continuously through the long vista of ages, or whether they are simply the result of special circumstances operating on the human mind in a certain stage of development. There is one department, however, in which this difficulty does not occur. Language has been in all ages a property of human beings. It is the connecting link between the present occupiers of this sublunary sphere, with all the accumulated wealth of untold ages, and the feeble savages who waged a not unequal war in the struggle for existence with the wild animals around. However diversified the various spoken dialects may be, there is no break of continuity. They can be traced backwards from children to parents, until they are lost in the night of antiquity. No new language has ever been invented in the history of mankind. We may, therefore, expect to find, imbedded in the innumerable languages existing in the world, indications beyond what are met with elsewhere of the general mind of humanity, as modified by outward circumstances and inward development; relics of archaic thought, feeling, and institutions; various modes adopted of attaining the same end of intelligibility by diverse means; and thus we may ultimately arrive at the primitive germs of thought expressing themselves in articulate speech.

Viewed in this aspect, philology has become a legitimate department of mental science. It has of late years made prodigious advances, and though not pursued in this country with the ardour which it might fairly claim, in other countries, and especially in Germany, it has engaged the attention and exercised the powers of some of the keenest intellects of modern times. No study has thrown so much light on the

early condition of the human race, and none promises in the future a richer harvest to reward the patient explorer.

I ask you, on the present occasion, to accompany me over a somewhat extended enquiry, whilst we take a general view of the present state of linguistic science. The field is so vast that all we can do within so limited a space is to take note of the salient points.

As a science, philology is of very recent date. The knowledge of languages, other than their own, possessed by the ancient Greeks and Romans, was very imperfect. To the Greeks, in every age from the time of Homer, those who did not speak the Hellenic tongue were βάρβαροι, babblers.

The subject of language was not neglected by the Greek philosophers. Plato, in his *Sophistes*, has treated on grammar and syntax; and in the *Cratylus* he has gone into the question of roots and derivations. It has been surmised that some of the speculations in the latter were intended rather in jest, bearing sarcastic references to the rhetoricians of his day.⁶

Aristotle has written largely on the philosophy of language, and other Greek writers followed in his track.

Amongst the Romans, M. Terentius Varro, a contem-

⁶ I have relegated to a footnote a few extracts from the *Cratylus*, as showing Plato's method of approaching the subject.

As to the connexion of languages, he says:—"If we consider foreign names, what each means is not the less discovered. I think that the Greeks, especially such as dwelt under the Barbarians, received many of their names from the Barbarians."

He seems to favour the onomatopoeian or ding-dong theory of the origin of language. "Names belong to things from nature; every one is not the artificer of names, but he alone who looks to that name which is naturally suited to each thing, and who is able to mould its form into letters and syllables." "If any one is able to imitate this very thing, the existence of each thing by letters and syllables, would he not indicate what each thing is?"

The element of ρ appeared to the founder of names to be a beautiful instrument of motion for the purpose of expressing a similitude to rushing on. Thus ρεῖν, to flow; ροή, flowing; τρέμω, trembling, etc. The letter λ is applied to the smooth and soft, etc.

porary of Cicero, wrote a treatise, *De Lingua Latina*, in which he compares the various languages spoken in Italy.

During the middle ages, previous to the revival of learning in the fifteenth and sixteenth centuries, philology, in our sense of the term, can hardly be said to have had any existence. Scholarship, meaning by this the critical study of the Greek and Latin languages, and the careful editing of the works of the classical writers, then began to flourish, and a succession of great names, such as those of George Buchanan, Isaac Casaubon, Joseph Justus Scaliger, and our own Bentley, formed a catena extending to the beginning of last century. Biblical scholarship has always more or less flourished, from the times of Origen and Jerome to the present day.

In the early part of the eighteenth century, a new school of classical philology, of a more searching and thorough character, arose in Germany, commenced by Franz Wolfgang Reiz, and continued by Hermann, Wolf, Schleiermacher, and K.O. Müller.

This school, however, advanced upon the old lines. Grammar, lexicography, criticism, and mythology were pursued with ardour and earnestness; but the connexion of languages, the family relations, the indications of community, the converging lines were entirely unknown. Comparative philology, as a study and science, extends very little backward from the beginning of the present century.

The labours of the lexicographers of the two last centuries are worthy of all commendation. The dictionaries of Wachter⁷ and Schilter,⁸ for High German; Ihre,⁹ for Norse; Ménage,¹⁰ for French; Forcellini,¹¹ for Latin; Min-

⁷ *Glossarium Germanicum*. Fol., Lipsic, 1787.

⁸ *Glossarium ad Scriptores Linguae Francicae et Alemannicae*. 8 vols., fol., Ulm., 1728.

⁹ *Glossarium Sniogothicum*. Fol., Upsala, 1789.

¹⁰ *Dictionnaire Etymologique*. 2 vols., fol., Paris, 1750.

¹¹ *Totius Latinitatis Lexicon*. 4 vols., fol., Paris, 1771.

sheu,¹² Skinner,¹³ and Junius,¹⁴ for English; in patient industry and extensive scholarship cannot be excelled; but the true key to the comparative study of languages had yet to be discovered, and much of their labour was expended in beating the air. Hebrew was considered the primæval language of mankind, Greek and Latin as in some way connected with it, and all other languages mere corruptions. Leibnitz was the first to question this unreasoning generalisation, and made an attempt to classify the languages of the world into families; but the time was not ripe, and the philosopher's attention was called off to other pursuits. It began to be felt that there was a connexion between the languages of the various members of the European family, but its nature and relations were entirely unknown. Vague conjectures and guesses supplied the place of more accurate knowledge.

It was the introduction, it might almost be said the discovery, of Sanskrit which furnished the key to solve these difficulties, and gave a new point of departure to comparative philology. It is to the efforts of Christian missionaries that we are mainly indebted for this new phase of enquiry. Hervas, a Spanish Jesuit missionary, was the first to point out the necessity of comparing languages, in their grammar and construction, as well as in mere similarity of sound. He showed the existence of the Semitic languages as a class apart, and discovered traces of affinity between the various European members of the Turanian family. Fra Paolino di San Bartolomeo, a Carmelite missionary, published at Rome, in 1790, the first Sanskrit grammar.

The progress of English ascendancy in the East gave a great impulse to the study of oriental tongues. Sir William Jones, judge of the Supreme Court in Bengal, and, after

¹² *Ductor in Linguas*. Fol., London, 1627.

¹³ *Etymologicon Lingvæ Anglicanæ*. Fol., London, 1671.

¹⁴ *Etymologicum Anglicanum*. Fol., Oxford, 1748.

him, Henry Colebrooke, did much to introduce the knowledge of Sanskrit, and of its affinities with the European tongues. William Carey and his fellow missionaries at Serampore were amongst the first thoroughly to master the difficulties of the study.

In 1806, J. C. Adelung published his *Mithridates*,¹⁵ being a general comparative view of the languages of the world, which, though necessarily imperfect, did much to call attention to the study of philology. From that time forward, the science has progressed with ever-increasing interest and success. In our own country, the names of Wilkins, Kennedy, Wilson, Pritchard, Max Müller, Monier Williams, Kemble, Sayce, Cleasby, and Rawlinson stand out with prominence, but Germany, in the number and profundity of philological works, far excels us. The names of the writers are almost numberless, and ever-increasing. Some of the most eminent are Franz Bopp, Aug. Fried. Pott, Jacob Grimm, Gabelenz and Løbe, Theodore Benfey, Aug. Fick, H. Meidinger, Caspar Zeuss, etc.

France has not entered into the study with the same ardour, but it is to two French scholars, Anquetil du Perron and Eugène Burnouf, that we owe our knowledge of the Zend or ancient Persian; and Professor Adolphe Pictet is the author of several elaborate works on the Indo-European languages.

The last half century has done more for comparative philology than all the ages preceding, and it is natural to inquire what has been the result. Where do we find ourselves? What light has been thrown on the history and origin of language, and on the relations and early development of the human race? These questions I will endeavour to answer as fully as my narrow limits will enable me to do.

In every pursuit which claims to be dignified with the

¹⁵ *Mithridates, oder Allgemeine Sprachkunde.* 5 vols., Berlin, 1806.

name of a science there are three stages of growth. First there is the collection of facts. Then come the generalisation and correlation of the facts, and the discovery of the laws governing these relations; and lastly the ultimate deductions to which we are led as the result of the analytical process adopted. As to the first stage in linguistic science, a large amount of facts has been collected. It has been established that the majority of the languages of Europe, and a number of those of Asia, are connected by family ties which unmistakably point to a common origin. These languages have been further classified into groups, the members of which have relations within themselves of a closer character than those uniting the groups. These are the Classical, comprising the Zend, Sanskrit, Greek, and Latin, and their modern descendants; the Teutonic, consisting of the High and Low German dialects, and the Norse; the Celtic, with its six divisions of Gaelic, Cymric, Cornish, Bas-breton, Pictish and Manx; and the Slavonic group, comprising the Russian, Polish, Lithuanian, Wendish, &c. Indications of a common origin are found in the vocabulary and the structure, and it is here that the evidences of law first begin to manifest themselves. The words in one group are not identified with those in another by exact similarity in sound, but by a substitution according to a regular and definite rule, which, from the name of Jacob Grimm, who first discovered it, is called "Grimm's law." I may exemplify this by an instance or two. In Greek, *τρεις*, in Latin *três*, is the third of the numerals. That they have a common origin in all the Indo-European languages is indubitable, but we must not look for identity. In the Low German group the medial *d* is represented by the aspirate *th*, and *três* becomes *threis*, or *three*. In the High German the *t* or *th* is exchanged for a medial or soft con-

sonant, and it becomes *drei*. So with other consonants. *Bhratar* in Sanskrit, *Frater* in Latin, becomes *brothar* in Low German, *prudar* in Old High German. These changes or equivalents are so uniform as to constitute a law, so that words in the different languages are identified, not by their likeness but by their differences, which may be predicted beforehand, according to certain rules. Thus if we take our English word *cow*, and wish to trace it through the kindred groups, we shall expect to find it with a medial or *g* in Sanskrit, and an aspirate in Old High German. Accordingly we meet with *gau* or *go* in the former, and *chua* in the latter, with the same signification. On this feature I cannot enlarge.

The relations of the great Indo-European family may be thus illustrated. Let us imagine a number of lines not parallel, but more or less converging, though broken, entangled and distorted, some stopping short, others prolonged. These appear at first sight incommensurable and impossible to reduce to system, but by patient skill it is found possible to ascertain their direction, and to find the common centre to which they all tend. This has been done with great success by some of our modern philologers. Professor Fick, of Göttingen, has thus brought out the elements of the original Aryan speech in a very interesting way.¹⁶

Another mode of inquiry somewhat resembles the method adopted by Sir Wm. Herschell, in gauging the starry deeps. By directing his telescope towards successive portions of the surrounding stellar system, and noting down the comparative number of stars in each observation, he was able to construct a map or model of the shape of the group to which our solar system belongs. Now, if we compare the various

¹⁶ *Die enemalige Sprachenheit.*—Göttingen, 1873. *Vergleichendes Wörterbuch der Indogermanischen Sprachen.* 8 vols., Göttingen, 1874.

languages belonging to the Aryan family, we shall find some words peculiar to a single group, or even a single language. Others are common to several, and a limited number are found in all. It is clear that those words which are found in every language of the family, or even in one language of every group, must have existed before the separation of the primeval stock. This would throw considerable light on the primitive condition of the race at the remote period before the migration from its original habitat, and the words peculiar to each group would equally illustrate the particular circumstances under which they originated. This task has been partially undertaken by Professor Adolphe Pictet¹⁷ with considerable success. A single example may suffice to illustrate my meaning.

The primitive root *ar* is found in all the Indo-European languages. From the primary meaning to push, it was applied to ploughing the soil, and appears in Greek *ἀρου*, Latin *ar-are*, Goth. *ar-jan*, Gaelic *ar*, A.S. *er-ian*, etc., and many other words in almost every dialect. When the nomadic tribes began to cultivate the ground, and adopt a settled life, the term *arya*, or ploughman, became an honourable distinction, and gave its name to the upper class, or nobility. Aryan thus became adopted as a generic term, which has been applied to the people and languages of Indo-European origin.

There is, however, another word for turning up the earth, which in all the northern parts of Europe has superseded the original term *ar*; German *pflügen*, Norse *plogr*, Slavonic *plug-u*, English *plough*. How this came about is a curious subject of inquiry. The date of its introduction is not known, but it is confined to the Teutonic and Slavonic races. In Gothic it is unknown; in the Norse tongues it is of late

¹⁷ *Les Origines Indo-Européennes ou les Aryas Primitifs*. 2 vols., Paris, 1863.

introduction, and we do not find it in our own language before the Conquest. Its history appears to be as follows :—

The original Roman *aratrum*, which is still in use in Italy and all the southern countries, was merely employed to scratch a furrow in the ground, which in that fertile soil and climate served all the purpose. The sterile soil and harsher climate of the north led to the adoption of a more powerful instrument, which not only scratched, but turned over the soil. To this was given the name of H.G. *pfluoeh*, from a root signifying to turn over, to work deep. This is one instance of the curious historical information which may be drawn from comparative philology.

We find then established, as an ascertained fact, the common origin and solidarity of the Aryan or Indo-European tongues. A collateral fact of equal importance is the essentially inflectional character of all these languages. By inflectional, is meant a structure which expresses its various shades of meaning by changes in the words themselves; prefixes, suffixes, and internal changes. In many modern representatives of the Aryan stock, and notably in our own language, this inflectional character has almost disappeared, but the further back we go the more decided does this feature become, and the more do these inflections, in each language, resemble each other. The Latin language, and, to a greater extent, the Greek, exhibit this character well developed, but it is in Sanskrit, the eldest sister, as it may be called, of the Aryan family, that the inflectional system is the most fully carried out. I wish to illustrate, as briefly as I can, the structure of an inflectional language, by reference to the Sanskrit.

Sanskrit grammar starts from roots. Of the origin and scientific nature of these I shall have to speak shortly. According to Max Müller, a root or radical is “whatever in

the words of any language, or family of languages, cannot be reduced to a simpler or more original form." It is a singular fact, account for it as we may, that the great majority of the roots in Sanskrit are expressive of general or abstract ideas. Thus, *gam* gives the idea of going, *sthá* of stability, *rad* of speaking, *da* of giving, etc. Sanskrit grammarians have estimated the number of radicals from which all the words in the language are derived, at about 1,700; but the simple elements to which a further analysis conducts us reduces the original number to less than 600. In the actual state of the language, the 1,700 dictionary roots are the vital principles out of which grows all the complicated plethora of words of one of the most copious languages existing. These roots, before they are fitted to receive the distinctive affixes, frequently have to undergo certain changes, to which it is not necessary here to refer.

Each verbal root is the base of six kinds of verbs, transitive, reflective, passive, causal, desiderative or optative, and frequentative or intensive. There are ten tenses in each, with three numbers and three persons. In addition to these there are the participles and infinitives. All of these are expressed by changes grafted on the root. Each verbal root, therefore, will give rise to about 679 separate inflections, including the declensions of the participles. Let us glance, for a moment, at the simple means by which this is effected. There are ten classes or conjugations, distinguished by the mode of forming the base from the root. We will take our instance from the first-class. The root *ráj*, has its equivalent in all the Aryan tongues, Latin *reg*, Greek *ἄρχειν*, Ger. *reich*, A.S. *ric*, Norse *rik-r*. Its primitive meaning is that of shining, distinguished, hence that of ruling. To adapt it to the form of a verb, the vowel *a* is added, giving the idea of movement. To this base so

formed, the pronominal suffixes of person and number are attached, *rajá-mi*, *rajá-si*, *rajá-ti*, I rule, thou rulest, etc. Some of the tenses have the augment *a*, corresponding to the Greek augment in *e*. The perfect tenses have a reduplicated form, *rarája*, such as originally existed in almost every Aryan tongue, Greek *τυπτω*, *τετυφα*, Latin *mordeo*, *momordi*, Goth. *tekan*, *taitok*. So *rajitasmi*, I will rule, equivalent to Latin *regam*; *rajayámi*, I cause to rule, *rajáyásam*, I wish I may rule; *raje*, I am ruled; *rarajishami*, I desire to rule; *rarajyami*, I frequently rule; *rarajayishámi*, I desire to cause to rule; and so on.

There can be no question that we have documents in Sanskrit older than those in any other Aryan tongue, and all evidence goes to show that this family of language, in its early stages, and during a long period of its history, has been essentially inflexional.

Besides this comes another family, with its records the most ancient in the world—the Semitic, comprising the Hebrew, Arabic, Phœnician, Amharic, and other ancient tongues long extinct. These possess a certain inflexional character, though comparatively imperfect. Whether there is any connexion between this and the Aryan family, is a moot point on which philologists are not agreed. There lie on the surface certain analogies of form, if not of substance, which cannot be overlooked on the most superficial survey. The structure of both is developed from roots, principally verbal; in the one case trilateral, depending entirely on the consonants; in the other monosyllabic, depending greatly on the vowels. The verbal inflexions in both are derived from pronominal forms, so far broken down as to have become mere enclitics. Compare, for instance, two verbs taken almost at random, one from the Sanskrit, the eldest sister of the Aryan family; the other from Hebrew, as representing the Semitic forms.

SANS.	HEBREW.
Root क च <i>Kach</i> , to bind.	Root קָשַׁר <i>Káshar</i> , he bound.
<i>Present Indicative Parasmai.</i>	<i>Kal Conjugation.</i>
<i>Kach-a-mi</i> , I bind.	<i>Káshar-ti</i> , I bound,
<i>Kach-a-si</i> , thou bindest.	<i>Káshar-tá</i> , thou didst bind, <i>mas.</i>
<i>Kach-a-ti</i> , he binds.	<i>Káshar-t</i> , <i>fem.</i>
	<i>Káshar</i> he bound, <i>mas.</i>
	<i>Káshar-ah</i> , <i>fem.</i>
<i>Plural.</i>	<i>Plural.</i>
<i>Kach-a-mas</i> , we bind.	<i>Káshar-nu</i> , we bound.
<i>Kach-a-tha</i> , ye bind.	<i>Káshar-tem</i> , ye bound, <i>mas.</i>
<i>Kach-a-nti</i> , they bind.	<i>Káshar-ten</i> , <i>fem.</i>
	<i>Káshar-u</i> , they bound.

There is here, saying nothing of the similarity of the roots, which may possibly be fortuitous, a strong analogy in the inflectional principle adopted.¹⁸

The assumption has too much prevailed that all the problems of the science of language will find their solution in the study of the Aryan tongues. This was the snare into which the earlier philologists fell, and from which the students of language are now only beginning to emerge.

We have then before us, as established facts, the original unity of the Aryan or Indo-European family of languages, and their inflectional character. Were our observations limited to these facts, it would not be difficult to frame a plausible hypothesis as to the origin and progress of human speech; but other indications have to be taken into account, of a widely different nature.

There are various methods of communicating thought; signs, gestures, tones, as well as articulate speech, and the

¹⁸ "The Semitic family is at once too small and too compact; its branches do not differ more among themselves than do the Romance languages in Europe; and until its Sanskrit has been found, as it may be in the old Egyptian or the Sub-Semitic idioms of Africa, we cannot get beyond a parent speech which is philologically late, and which fails to offer that facility for comparison which is needed by the young glottologist."—Sayce, *Principles of Comparative Philology*, p. 70.

latter has frequently to be eked out and supplemented by the former. The mind has a wonderful aptitude in supplying the missing links when the main points of a communication are presented. We see this in the language of childhood. Who could mistake the expression of a tired child, "Mamma—up!" or the yielding to authority, after a tempest of infantile wrath, in the single words, "Papa—good." There are existing languages in which the same syllable stands for far different meanings, according to the tone in which it is uttered. Thus, in the Annamitic language, the syllable *ba* has a variety of significations, according to the mode in which it is pronounced. With no accent or tone it means *three*; with the grave accent it means a lady; with the acute accent it means a favourite of a prince; with the interrogative tone it means a box on the ear.¹⁹

Ba, bà, bá, ba? therefore means, if properly pronounced, "three ladies (gave) the prince's favourite a box on the ear."

Now this monosyllabic mode of speech constitutes the language of nearly one-half of the human race, including the teeming millions of China, Cochin-China, Thibet, Burmah, Siam, and Cambodia. Forming such a very important element in any comparative analysis of human speech, a brief synopsis of Chinese grammar may not be out of place. A great deal of absurdity has been written about the Chinese language. It has been gravely maintained that the spoken and written languages are entirely independent of each other, Chinese writing, like the Arabic numerals, being ideographic, conveying the same meaning to persons speaking dialects entirely different. The slightest consideration will show the utter impossibility of such a state of things, the accomplishment of which would necessitate a conference of persons phonetically conversant with all the languages, to agree upon a code, something in the same way as Marryat's marine signals

¹⁹ Max Müller, *Lectures*, 2nd ser., p. 30.

giving a symbol for every shade and combination of thought which could cross the human mind. The mere statement of such a proposition is sufficient to show its absurdity.

It is true that some utterances of the writers on the Chinese language appear to give countenance to this idea. Morrison²⁰ says, "They have no alphabet. The character presents nothing to the eye by which its pronunciation can be ascertained. It attempts to communicate the meaning, regardless of the sound." Dr. Marshman²¹ says, "The sound of no character is inherent therein; it may be totally changed without affecting the meaning of the character." These statements are strangely at variance with others elsewhere made by the same writers. Dr. Marshman says,²² "Speech must necessarily precede writing, and some colloquial mode of communication must have preceded the invention of the Chinese characters."

"If, when the Chinese invented the characters, they did not affix to them the sounds with which they had already connected ideas, of what service could these characters be when invented? New sounds could convey no ideas till these sounds were universally recognised as connected with ideas; and, in order to affect this, a nation must agree to throw aside the sounds with which alone they had hitherto connected ideas, and in reality invent for themselves a new language—a circumstance unparalleled in the history of mankind. We have therefore no sufficient ground to conclude that any colloquial medium widely different from the present has at any time existed in China; but, on the contrary, the probability is that the present system existed in substance prior to the invention of the characters."²³

No fewer than six Chinese pronouncing dictionaries have been published by Imperial authority; the first A.C. 150, and

²⁰ *A Grammar of the Chinese Language*. Serampore, 1815, p. 1.

²¹ *Elements of Chinese Grammar*. Serampore, 1814, p. 81.

²² *Ibid.*, p. 82.

²³ *Ibid.*, p. 88.

the last at the beginning of the eighteenth century. As the seat of government had been removed in the intervals of each publication, the phonetics of the characters have varied with the pronunciation of the provinces from whence the dictionaries have been issued. Here, in fact, lies the solution of the whole mystery. If we could imagine, in our own language, the same written characters employed, and at the same time the dialectic differences increased tenfold, being in proportion to the population of each country, we may form some notion of the relation of the spoken to the written language in China. This difference has been increased also by other circumstances. Although Chinese has no alphabet or letters, each character standing for a syllable, yet there are what are called initial²⁴ and final sounds²⁵ applied to the pronunciation, which are practically equivalent to vowels and consonants. It is a remarkable fact that these sounds, so far as they go, are identical with the Sanskrit letters. The combination of these initials and finals, omitting duplicates, gives 629 distinct monosyllables. These, again, are varied in their expression and meaning by the tones in utterance, of which there are four. This should produce about 2,500 distinct intonations, but as a matter of fact there are only 1,781. "The Chinese, ignorant of the polysyllabic system, and unable to form a conception of any sound beyond those produced, as already described, were ready enough to apply a new character to a new idea; but to express such new character they fell back upon sounds already existing. The same sound thus frequently applies to characters of entirely different meaning, which has to be supplemented by gesture relation to the subject, and position."

"A Chinese character may consist of two parts; a radical, which conveys a fundamental notion, and a phonetic, which indicates the sound. This is not, however, constantly the

²⁴ *Tse-moo*, mother sounds.

²⁵ *Nyèh*, auxiliary sounds.

case. The compound character which extends the meaning of the radical may have a different sound from either of the component parts. The number of characters is upwards of 40,000, but a large proportion are obsolete, and many are merely variations not in use. Not more than 10,000 enter into use, and 5,000 are quite sufficient for ordinary purposes.²⁶ The expression of such a large number of ideas by a limited number of sounds must necessarily lead to confusion. In writing, the sense is clear enough; but in speaking, the sense has to be gathered by the cohesion, intonation, emphasis, and position, which produces the same effect as if the language were polysyllabic; the difference being that every syllable has a meaning."²⁷

The Chinese system of writing has many points in common with the Egyptian hieroglyphics. Both are phonetic. In Chinese the whole, and in Egyptian the greater part, of the signs stand for syllables or words. In both the medial sounds, *b*, *g*, *d*, and *z*, are wanting. In both there is no distinction between *l* and *r*. In both signs are added to eke out the original meaning of the symbol.²⁸

We have, then, in Chinese the type of a monosyllabic language without inflections. Every syllable or sound has a meaning, which is modified by its position in the sentence, and expressed by the tone in which it is pronounced. In this way every minute shade of meaning finds expression equally with the most complicated inflectional language. Gender, case, the various tenses of verbs, comparatives, superlatives, etc., are all indicated by superadded characters.

There must always in this mode of expression be somewhat of an elliptical character; *e.g.*, the sentence, "If the

²⁶ Summers, *Rudiments of the Chinese Language*, 1864.

²⁷ *Ibid.*, p. 8.

²⁸ See Renouf, *Elementary Grammar of the Ancient Egyptian Language*.

disciple be at home, filial piety then becomes his business ; if he be abroad, fraternal respect," is thus expressed.

"Teè tsï yěh , tsūh hyaò ; tchyūh tsūh

The disciple entering, then filial duty ; without, then teè.

fraternal respect.

Perhaps of all living languages the English lends itself the most readily to this mode of construction. There is much in common between the English and Chinese. In the one the entire, in the other the almost entire absence of inflection ; in both, the same word may be employed without change either as a substantive, adjective, or verb, which is peculiar to the English amongst European tongues.

Take *love* as a verb : "I *love* them that *love* me ;" as a substantive : "*love* is the brightest of the train ;" as an adjective : "I have received a *love*-letter," etc. English also resembles the Chinese in the great number of monosyllables in the language.

It is probably this similarity which has facilitated the formation of the jargon called "Pigeon English," which is the medium of communication at Canton and the other ports. It is simply English words and Chinese construction, with the introduction of a few Chinese terms. As the Chinese do not possess the sounds of *b*, *g* hard, and *d*; *l* being the substitute for *r*, and *s* being pronounced with difficulty, *pigeon* is the nearest approach of John Chinaman to the word *business*.

The following is a specimen, being a letter of introduction to a Chinese merchant, given by an English friend :—

"Mi chin chin you ; this one velly good flin belong mi, mi wantchee you do plopl pigeon long he all same fashion long mi ; spose no do plopl pigeon, mi flin cum downside mi housie, talkee mi so fashion ; mi kick up bobbery long you."

This is the reply :—" Mi savey no casion makery flaid ; can secure do plopel pigeon long you flin, all same fashion long you."²⁹ This is perfectly intelligible, and true Chinese construction.

We have then in our speculations on language to take into account the fact of a system diametrically opposite to the Aryan, and claiming an equal position as an independent member of the human family.

We come now to another great division in the families of human speech, what is called for convenience the Turanian family. This term is of Persian origin. The Persians called their own country *Irán*, which is only another modification of *Aryan*. The nomadic races of the wide Asiatic plains, with whom they frequently came into collision, they called *Turan*, from a word signifying "swiftness."

This class of languages is termed the agglutinative or combinatory, holding a middle place between the Aryan or inflectional, and the monosyllabic or non-inflectional. In these tongues the meaning of words is modified by suffixes, but these suffixes have not lost their meanings. They are not mere auxiliaries or enclitics, useless apart from the words to which they are attached. The grammar of the language, therefore, is simply the mode in which its independent elements are combined together. Thus, in the Turkish language, *sevme* means to love, *sevmemek* not to love, *sevdirme* to cause to love, *sevilmek* to be loved, *sevinmek* to love oneself, to rejoice, *sevinehmemek* not to be able to rejoice, *sevishmek* to love mutually, *sevishémmemek* not to be able to love mutually, and so on. It will be perceived that this process does not differ materially from the mode of building up the Sanskrit verb ; but with this difference, that the component parts which in Sanskrit have lost their meaning

²⁹ Dr. Daniel Wilson, *Prehistoric Man*, vol. i., p. 428.

except in the combinations they form, in the Turanian languages are living independent words. The language thus developed becomes eminently polysyllabic.³⁰

Mr. Edkins³¹ says:—"The dividing line is a sharp one, which the traveller crosses from the region of tone systems, and carefully pronounced inflexions of the voice, to the freedom of polysyllabic speech. He suddenly finds himself where tonic laws have been thrown away, and all accented and inflected elocution has been transferred from the region of the syllabary and the vocabulary to that of the passions and the will. It is but a short distance from the Chinese city to the Mongol encampment, but the change is great."

At the height of 2,000 feet commences the table land, which has received the name of the "land of grass." Pastoral occupations take the place of field labour, and a limitless horizon is only varied by the undulations of the vast prairie. It is in these boundless plains, amongst the roving Tartar and Scythian, that the Turanian family of languages had their birthplace. The field over which these languages prevail is very wide, extending from the extreme east of Asia to the centre of Europe. The Japanese forms the eastern division. In the north, we find Mongols, Manchus, and other Tartar tribes, with the Tungusians and Samoyedes. The southern division occupies the Deccan and a considerable portion of India, constituting what are called the Dravidian languages, the Tamil, Telugu, Malay, etc. The western division consists of the Turkish, Hungarian, Esthonian, Finnic, Lapp, and probably the Basque.

The three grand divisions of which I have spoken were, until recently, supposed to include every variety of human speech:—

The monosyllabic, in which inflection is unknown.

³⁰ See Burckhardt Barker, *Turkish Grammar*, 1854.

³¹ *China's Place in Philology*, 1871, p. 139.

The agglutinative, in which expression depends on the combination of monosyllabic words.

The inflectional, in which the root-words branch out into every shade of meaning by the annexation of particles and affixes.

This, however, has of late years begun to be very seriously questioned. The languages of Europe and Asia have been very carefully studied and classified, but, in the words of Scripture, "there remaineth yet very much land to be possessed." The facility of intercourse has brought under our notice a multiplicity of languages in Africa, America, and Polynesia, differing in almost every point of view, and refusing to be classified with those already known. The hypotheses, founded solely upon the facts previously established, may therefore have to be very extensively modified. A new school of philology has arisen, which oversteps the ancient landmarks, and questions the principles which have to a great extent been accepted as irrefragable truths.

In the progress of every science there is always a tendency for generalisations and hypotheses to overrun the facts on which they are based. This is inevitable, and has to be corrected from time to time as knowledge advances.

The threefold classification to which I have just referred owes its origin to the Chevalier Bunsen²³ and Professor Max Müller.²³ It is supported by Professor Whitney,²⁴ and has received very general acceptance. Latterly, it has been seriously called in question by the most advanced school of philologists. M. Ernest Rénan observes :—

"L'hypothèse d'une famille *touranienne*, par laquelle on cherche à établir un lien de parenté entre des langues entièrement diverses, nous paraît gratuite, et formée par des

²³ *Outlines of the Philosophy of Universal History*. London, 1854.

²³ *Lectures on the Science of Language*, 1st ser., p. 276.

²⁴ *Language, and the Study of Language*, 1867, p. 360.

procedés qui ne sont pas ceux de la science rigoureuse.”
 “Ainsi en a jugé également un esprit à la fois sévère et hardi, M. Pott,²⁵ qui en rendant pleine justice aux vues ingénieuses que le savant M. Müller a semées dans son ouvrage, le juge pour l'ensemble peu conforme aux vrais principes de la philologie comparée, et capable d'égarer une étude déjà entourée de tant de périls.”²⁶

Mr. Sayce writes :—“It is implied in the ordinary classification that families of speech analogous to the Aryan are to be found all the world over. Every idiom, ancient or modern, has to be brought, willing-nilling, under some ‘family’; the admission that a language may be *sui generis* is never even dreamt of. We have even had a ‘Turanian family’ invented, into which everything that is not Aryan or Semitic has been thrust, from Turkish and Tamulian to Chinese and Red Indian.”.....“Now that the term ‘Turanian’ is more properly confined to a chain of certain dialects, a new family has been brought into existence, to be called agglutinative, or allophyllian, or heaven knows what.”²⁷

It is quite certain that the old classification can no longer be maintained. The multiplicity of African and American languages, brought to light by recent research, many of them of the most complicated character,²⁸ refuse to be dealt with in this Procrustean fashion, and the time is not yet arrived for the foundation of a true theory embracing all the phenomena.

Another moot point, on which an irreconcilable difference exists, is as to the nature of *roots*. All languages

²⁵ *Zeitschrift der Deutschen Morgenländischen Gesellschaft*, 1855.

²⁶ *De l'Origine du Langage*, Paris, 1864, pp. 41-43.

²⁷ *Principles of Comparative Philology*, 2nd ed., 1875, p. 100.

²⁸ “Les langues des sauvages de l’Amérique, celles des habitants de l’Afrique centrale et méridionale, qui commencent à fournir à la science des révélations inattendues, offrent une richesse grammaticale vraiment surprenante.”—Renan, *ut sup.*, p. 18.

must have had some rudimentary form, and it is the most natural idea that the simple should precede the complex, and that the abstract should grow out of the concrete.

Roots have been considered as the primitive elements out of which language has been formed. Max Müller says:—

“After explaining everything in the growth of language that can be explained, there remains in the end, as the only inexplicable residuum, what we call roots. These roots form the constituent elements of all languages. This discovery has simplified the problem of the origin of language immensely. What, then, are these roots? In our modern languages, roots can only be discovered by scientific analysis, and, even as far back as Sanskrit, we may say that no root was ever used as a noun, or as a verb. But originally roots were thus used, and in Chinese we have them preserved to us as a representative of the primitive radical stage.”³⁹ “A root is always monosyllabic. Roots consisting of more than one syllable can always be proved to be derivative roots.”⁴⁰

To the theory thus stated several objections have been started. If it be true, according to Locke, that there is “*nihil in mente quod non prius in sensu*,” we should expect to find the radical elements of an inflectional language consisting of concrete ideas—names of things; but the reverse of this is the fact. As stated by Mr. Sayce:—

“Roots, in the lexical or grammatical sense of the term, are those ultimate phonetic elements discovered by an analysis of groups of allied words, and they stand in the same relation to words as letters and syllables do to them.”⁴¹

In the eldest sister of the Aryan family, the Sanskrit, where alone we can look for true roots, they are nearly

³⁹ *Lectures*, 1st ser., p. 342.

⁴⁰ *Ibid*, p. 249.

⁴¹ *Principles of Comp. Philology*, pref. vi.

all abstract or general terms. Thus *gam* and *sthá* do not signify to go, and to stand, but the general idea of movement and stability, and have to be modified in their application as nouns and verbs. In this sense the Chinese primitives are not roots, but actual words, which are employed in ordinary speech and writing, and are modified by accretions, position, and tones.

“ We know that with certain exceptions, about which there can be little controversy, all our words are derived from roots, and that every one of these roots is derived from a general concept. ‘Without roots no languages, without concepts no roots.’ These are the two pillars on which our philosophy of language stands, and with which it falls.”⁴²

Out of the twenty-six letters of the English alphabet all our words are formed ; but we know that the letters did not exist previously to the words, but are arrived at by the ultimate analysis of the sounds issuing from the lips. So the roots in the Aryan tongues are only discovered by a laborious elimination of all the modifications of expression, until the central idea is reached. This, when found, is usually expressed by a monosyllable, but we have no ground whatever for maintaining that this was the mode in which language originated. Chinese is pointed to as an instance of the principle, but we have no more right to maintain that Chinese has been always monosyllabic than that the Aryan branch has been always polysyllabic. The tendency in all languages, so far as experience goes, is from the synthetic to the analytic, and never in a contrary direction.

If the principle of monosyllabic roots is to be maintained, probably the most complete theory is that of Dr. Alexander Murray, Professor of Oriental Languages in the University of Edinburgh, who, in his learned work, the *History of the*

⁴² Max Müller, *Chips*, vol. iv., p. 477.

European Languages,⁴³ seriously propounds "that all languages are founded on a single language, which originated out of nine words or syllables—Ag, Bag, Thwag, Gwag, Lag, Mag, Nag, Rag, Swag." These give the idea of action in its various forms. If the first difficulty be got over, the work is able, and the reasoning powerful, if not convincing.

A very similar view of the origin of radicals is given by Liancourt and Pincott, in their work entitled *Primitive and Universal Laws of Language*, 1874. They adopt the onomatopoeic theory, and reduce the essence to single letters—G, I, L, P, T, etc.

Max Müller maintains,⁴⁴ and is supported by Professor Whitney,⁴⁵ that every inflectional language was once agglutinative, and every agglutinative language once monosyllabic. The necessity for this is denied by M. Renan and Mr. Sayce. It is argued that, if this were so, the change from one form to the other would indicate progress in civilisation and the arts, whereas, in point of fact, some of the rudest races in Central Africa, and the Esquimaux, possess languages in the highest degree synthetic and inflectional; whilst the Chinese, whose language is entirely monosyllabic, have attained a high degree of civilisation, and literature of a particular kind. It is further argued, that if the theory of the three stages were true, some historical evidence would be forthcoming in support of it; that at the remotest period to which our researches can extend, we should find the simple elements gradually crystallising into the synthetic form. In reality, the very reverse of this is the case. The further we go back in our inquiries, the more complex and synthetic does language become.⁴⁶

⁴³ *History of the European Languages*. Edinburgh, 2 vols., 1823.

⁴⁴ *Lectures*, 1st ser., p. 317.

⁴⁵ *Language*, pp. 256-80.

⁴⁶ La marche des langues vers l'analyse correspond à la marche de l'esprit humain vers une réflexion de plus en plus claire; cette tendance commune de

The modern English is probably the most analytic in its structure of all the Aryan family of tongues. We claim for it a power, capacity, and precision second to none and superior to most. This claim has been admitted by some of the greatest masters of language. Jacob Grimm says of it:—“This English may truly be called a world language, and seems, like England herself, destined to rule over all the corners of the earth. In wealth, wisdom, and economy, none of the living languages can vie with it.” Yet, what do we find? The ultimate result of all this growth has been to give our language a greater approximation to the monosyllabic non-inflectional Chinese than is possessed by any other tongue.

We pass from this to another disputed point. Are all languages derived from a single original, or has the source of each family been an independent creation? Has the progress of language moved in radiating or parallel lines? This question, although closely allied to that of the unity of the human race, is not necessarily identified with it. It is possible to conceive that, in its rudimentary condition, the genus *Homo* might have existed for a considerable period without articulate speech. In regard to this subject a great change has passed over the philosophic mind. It has always been difficult to separate this question from theology and revelation. Down to a recent period, it was a fixed axiom of the advanced school, that to deduce the origin of mankind from a single centre was an absurdity; but, since the theory of development has been so prominent, there has been a revulsion in the opposite direction. Mr. Sayce says:—“No utterance of science is clearer than this, that all which is

l'esprit humain et du langage a existé dès le premier jour; c'est donc au premier jour qu'il faut placer le plus haut degré de synthése. . . . Il est probable que dans le langage de l'homme primitif, ainsi que cela a lieu dans celui de l'enfant, l'expression de la pensée se produisait comme un ensemble, et sous la forme d'une riche complexité.”—Renan, *ut sup.*, p. 12.

now in being is the result of evolution or development ; that, look where we will, to the most distant horizon of space, or the dimmest antiquity of time, there is no break, no void, nothing but an unvarying, unchangeable continuity of progress. Darwinism is the most fashionable hypothesis of our day, and Darwinism is supposed to imply a common type and a single pair of ancestors. But some, even of the most advanced supporters of the Darwinian theory, have themselves been obliged to resign the homogeneity of the human race, so far as origin is concerned.... We have all been cast in the same mould, or, as St. Paul puts it, we have all the same blood ; but it does not follow that we all come from the same ancestry, still less that all languages have radiated from the same centre.”⁴⁷

Professor Max Müller is not very decided as to the single or plural origin of languages,⁴⁸ but leans to the former, in which he is supported by Mr. Whitney.⁴⁹

Mr. Edkins is strongly in favour of a common origin,⁵⁰ to which Professor Legge assents in somewhat measured terms.⁵¹ M. Renan is decided in the other direction.⁵²

From this we are naturally led to the speculations on the origin of language, which have occupied men's minds from the time of Plato to the present day.

The idea long held was that language was a divine gift,

⁴⁷ *Principles, etc.*, p. 102.

⁴⁸ See *Lectures*, 1st ser., pp. 313-327.

⁴⁹ *Language*, pp. 384-397.

⁵⁰ *China's Place, &c.* Introduction.

⁵¹ *Report on Chinese, &c.* See President's Address to *Philological Society*, 1875, p. 42.

⁵² S'il est en effet, un résultat incontestable, c'est que le réseau des langues qui ont été ou sont encore parlées, sur la surface du globe, se divise en familles absolument irréductibles l'une à l'autre, . . . le langage n'a point une origine unique, il s'est produit parallèlement sur plusieurs points à la fois. Ces points ont pu être fort rapprochés ; les apparitions ont pu être presque simultanécs ; mais certainement elles ont été distinctes et le principe de l'ancienne école, " Toutes les langues sont des dialectes d'une seule " doit être abandonné à jamais.—*De l'Origine du Langage*, p. 202.

that when man was created, the faculty of speech, along with reason, was conferred upon him, at least in its radical form, so far as to enable him to name the objects of sense, and to hold communion with his kind. This view, in modern times, has been almost entirely abandoned. The faculty is still conceded, but its exercise is admitted to be entirely of human origin.

Three theories have been propounded of the human origin of language, respectively termed the "bow-wow" or "ding-dong" theory; the "pooh-pooh"; and the "jelly fish" theory. Let us take them in order. The first draws the inference that primitive roots are imitations of natural sounds, whether animate or inanimate. The voices of birds, the lowing of cattle, the moaning of the sea, the crash of the falling forest, the rustling of the leaves, the hum of the bee, led to imitations in the human voice, and thence to articulate speech. Herder and Steinthal, in Germany, have been the chief exponents of this theory, which has been revived in England by Mr. Hensleigh Wedgwood, with great ability.⁵⁸

There can be no doubt that a number of words in every language have been formed on the principle of onomatopoeia, or imitation of nature, but the proportion of these terms, in any language, is not large. To a certain extent this language, like that of signs, is intelligible in every idiom. We all remember the story of the Englishman, who, at the table of a Chinese mandarin, wishing to know the contents of a particular dish, exclaimed, in an interrogative tone, "Quack, quack?" The reply, in a grave tone of affirmation, was "Bow-wow." The objection to this theory is, that the basis is not broad enough to build a theory upon; that if the origin of language could be accounted for in this way, the principle would apply universally, and not spasmodically,

⁵⁸ *A Dictionary of English Etymology*. 4 vols., 1859.

some sounds adopted in one language and others in another, and, as a matter of fact, the great bulk of language is not, and never was, onomatopoeitic.

The second theory is the interjectional one, viz., that there are natural sounds by which we express fear, pain, joy, excitement, or pleasure, and that these are capable of forming the basis of an articulate language.

The best reply to this is, perhaps, that of Horne Tooke, that the dominion of speech is erected on the downfall of interjections. Speech begins where interjections end. It would be difficult to find many mere cries of pain or pleasure which have been incorporated as parts of speech. These two theories failing, on what have we to fall back? We have already seen that all the phenomena point to a synthetical origin of language, that is, that the first utterances were rather comprehensive than discriminative. This view has been followed up by Mr. Sayce, in his able work on the *Principles of Comparative Philology*, already alluded to. The same idea had previously been broached by M. Renan, "Je persiste donc, après dix ans de nouvelles études à envisager le langage comme formé d'un seul coup et comme sorti instantanément du génie de chaque race. . . . Bien qu'arrivé peu à peu à la pleine évolution de toutes ses puissances, le langage fut intégralement constitué dès le premier jour; de même que dans le bouton de fleur, la fleur est tout entière avec ses parties essentielles, quoique ces parties soient loin d'avoir atteint leur complet épanouissement."⁶⁴

Waitz also, in his *Anthropologie der Naturvölker*, published in 1858, has come to the same conclusion. He says "We do not think in words, but in sentences; hence we may assert that a living language consists of sentences, not of words. But a sentence is formed not of single independent

⁶⁴ Renan, *ut sup.*, p. 16.

words, but of words which refer to one another in a particular manner, like a corresponding thought, which does not consist of single independent ideas, but of such as, connected, form a whole, and determine one another mutually.”⁵⁵

“ Nothing can be more intricate, more complex, than the grammar of the Red Indian, or of the Eskimaux. . . . Out of the manifold comes the simple, out of the multitudinous the single. . . . The meaning of words begins with a confused vagueness, out of which definite forms with definite significations are gradually evolved. Language is the expression of thought; and the first ideas were as much undifferentiated embryos as the jelly fish on the shore, or the bee-hive life of primeval man.⁵⁶ Hence the principle, so propounded, has had the name of the *jelly fish* theory attached to it. The idea is that the primary utterances, in the way of language, were confused attempts to express mental impressions and conceptions, which would be quite as frequently complex as simple; and just as the substance of the jelly fish possesses all the elements of organism in a plastic form, so the first attempts to embody thought in speech would be capable of analysis and adaptation, as conceptions grew clearer, and their application more specific.

Dr. Moffat, in his *Missionary Scenes in Southern Africa*, informs us that the isolated villagers of the desert are often compelled to be absent from their homes for weeks at a time, leaving their children to the care of two or three infirm old people. Under these circumstances, the children, some of whom are beginning to lisp, while others can just master a whole sentence, and those still further advanced, romping and playing together, become habituated to a language of their own. The more voluble condescend to the less precocious, and thus from this infant Babel proceeds a

⁵⁵ Quoted by Mr. Sayce, p. 136.

⁵⁶ Sayce, p. 243.

dialect of a host of mongrel words and phrases joined together without rule, and in the course of one generation the entire character of the language is changed."

The same process appears to be going on in many of the Polynesian Islands, where certain expressions are tabooed and others invented in place of them. This takes place according to no grammatical rules.

The mode in which words are introduced into a language is curious, sometimes ludicrous. Amongst the red Indians near Fort Vancouver, in the Hudson's Bay territory, the common salutation on meeting each other is "clak-hoh-ah-yah," which seems a formidable Turanian word. It is, however, of English parentage, and arose in this way. A person named Clarke occupied a prominent position at the fort, and when he turned out in the morning, his numerous friends greeted him with the usual inquiry, "Clarke, how are you"? The natives constantly hearing this, imagined it to be a general form of salutation, and adopted it in the form above.

The passage from the Latin word *pilus*, to English *wig*, is a singular specimen of derivation. *Pilus*, by a common interchange of *l* and *r*, became in Italian *perruca*, in French *perruque*, which in English was metamorphised into *perwiche* and *perriwig*, and, by the usual English tendency, the first part of the word was abandoned, and it was shortened to *wig*.

All languages, in their early stages, abound in epithets which are restricted to particular objects or actions, and are only gradually superseded by general terms, embodying some idea common to all. Grimm says, "The idiom of nomads contains an abundant wealth of manifold expressions for swords and weapons, and for the different stages in the life of their cattle." Lady Juliana Berners, in the fifteenth century,⁵⁷ informs us that we must not use the names of

⁵⁷ *Book of St. Albans.*

multitudes promiscuously, but, “a congregation of people, a host of men, a bevy of ladies, a herd of deer, a siege of herons, a muster of peacocks, a flight of doves,” &c. So, in the Sanskrit language, water to drink, standing water, flowing water, have each a separate word to express them, besides the general term *jalam*, for water as a fluid. The idea of *going* has no general term, but is expressed by forty or fifty different words, according to the particular class of movement intended. In the earliest stage of language, every action or thing appears to have had a specific phonetic expression, and it has been out of this wealth of raw material that general words have been evolved.⁵⁶

The narrow limits of this address will not permit me to enlarge upon this phase of linguistic science, but it will be evident that the points in dispute present subjects for inquiry of a very attractive and interesting character, whether it be possible or not to arrive at a satisfactory solution. There is yet one inquiry, collateral, but closely connected with the subject, on which I wish to say a few words before concluding. I mean the relations of thought and speech. The inquiry is to a considerable extent metaphysical and psychological, yet it has an important bearing on the history and development of language. Some philosophers maintain that language is essential to thought—without speech, no reason. Others contend that, as thought precedes language, which is merely its expression, it must, to a certain extent at least, be independent of speech. The weight of authorities is undoubtedly on this side of the question. Locke maintains that we can form mental conceptions and propositions without words; that words are signs added to our conceptions, and added arbitrarily. At the same time he admits

⁵⁶ Languages in a low state of development are rich in words expressive of the most minute differences, but poor in general expressions.—Max Müller, *Chips*, vol. 4, p. 124.

that it is almost unavoidable, in treating of mental propositions, to make use of words, and, further, that it is possible to use words without ideas. "Most men," he says, "if not all, in their thinking and reasoning within themselves, make use of words instead of ideas, at least when the subject of their meditation contains in it complex ideas."⁵⁹

Dr. Thomas Brown says, "That man can reason without language of any kind, and consequently without general terms—though the opposite opinion is maintained by many very eminent philosophers—seems to me not to admit of any reasonable doubt, or, if it required any proof, to be sufficiently shown by the very invention of language, which involves these general terms; and still more sensibly by the conduct of the uninstructed deaf and dumb—to which also the evident marks of reasoning in other animals—of reasoning which I cannot but think as unquestionable as the instincts that mingle with it—may be said to furnish a very striking additional argument from analogy."⁶⁰

Amongst later writers, Mr. Sayce⁶¹ says, "Language is the outward reflection and expression of thought, or, more accurately, it is the best attempt we can make to represent externally, and communicate to others, what is passing in our own minds. It is true that it can only be an attempt; no outward representation of thought can be otherwise than inadequate. But for all that, it does represent and embody thought, and words are as much fossilised ideas as the petrifications of the rocks are fossilised relics of the creatures of old time. Thought creates language, but language, in its turn, creates thought."

The question whether language is necessary for reason and thought has been brought into remarkable prominence within a recent period. Mr. Darwin's work, *On the Descent*

⁵⁹ *On the Human Understanding*, iii. 2, iv. 5.

⁶⁰ *Works*, i. 475, ii. 446.

⁶¹ *Contemporary Review*, April, 1876.

of *Man*, published in 1871, gave a shock to the usually received opinions on the radical and generic distinction between man and the lower animals; the theory of evolution and development, so powerfully advocated by this distinguished philosopher, laying down the principle that the difference was one of degree rather than kind. It was denied that articulate speech is essential to reason and thought, and maintained that human language started from the same level as the note of the cuckoo or the barking of the dog.

Professor Max Müller, seven years before the publication of Mr. Darwin's work, had laid down with great force the very opposite theory. He says, "As a matter of fact we never meet with articulate sounds except as wedded to determinate ideas, nor do we ever, I believe, meet with determinate ideas except as bodied forth in articulate sounds. This is a point of some importance, on which there ought not to be any doubt or haze, and I therefore declare my conviction, whether right or wrong, as explicitly as possible, that thought, in the sense of reasoning, is impossible without language. . . . We must concede to animals sensation, perception, memory, will, and judgment, but we cannot allow to them a trace of what the Greek called *lógos*, *i.e.*, reason."⁶² Again, "Without speech no reason, without reason no speech. It is curious to observe the unwillingness with which many philosophers admit this, and the attempts they make to escape from this conclusion, all owing to the very influence of language, which in most modern dialects has produced two words, one for language, the other for reason; thus leading the speaker to suppose that there is a substantial difference between the two, and not a mere formal difference." In support of these views he cites Hegel and Schelling.⁶³

⁶² *Lectures*, 2nd ser., p. 62.

⁶³ Quoted by Pott, *Etymolog. Forsch.*, ii. p. 261.

In December, 1872, Mr. Müller delivered the Roscoe Lecture in Liverpool, in connection with this Society. The subject was "Darwin's Philosophy of Language,"⁶⁴ in which the Professor controverted the development theory, and maintained that language is the true barrier between man and beast. The subject slumbered for more than a year, but in July, 1874, an article appeared in the *North American Review*, from the pen of Prof. Whitney, of Yale College, professedly a review of a work by Schleicher, *Ueber die Bedeutung für die Naturgeschichte des Menschen*, but in reality a somewhat severe commentary on Mr. Müller's lecture. He observes, "Reason is that power over general concepts which we possess, and which is so much higher than anything possessed by brutes, that it is properly called by a different name." Mr. Müller had conceded to animals "perception, memory, will, and judgment," but denied them "reason." On this, Mr. Whitney remarks, "To put the formation of general concepts at the very top, and the power of weighing probabilities and calculating results, even genius itself, far below, is to turn the natural order of things topsy-turvy. Nor is articulate language, or language of any kind, the only intelligible manifestation of reason. There is rational conduct as well as rational speech, and it is quite as effective as speech." Both in this review and in his previous work on language, Mr. Whitney controverts, with earnestness, Mr. Müller's theory of the identity of speech and reason.

In the *Contemporary Review*, for September, 1874, Mr. George Darwin published an article, ostensibly on Mr. Whitney, but in reality a reply to Mr. Müller's strictures on Mr. Charles Darwin's *Descent of Man*, in which he puts forward Mr. Whitney as the supporter and champion of views of a decidedly opposite character.

⁶⁴ Subsequently published separately.

In January, 1875, Mr. Müller again entered the field, by an article in the *Contemporary*, entitled, "My Reply to Mr. Darwin," in which the whole ground is again traversed. In the course of his remarks he quotes Professor Carriere, of Munich, animadverting on Mr. Whitney, as follows:—"The American scholar did not see that language is meant first for forming, afterwards for communicating, thought. We can have sensations, desires, but we cannot think, in the proper sense of the word, without language. Every word expresses the general. Mr. Whitney has not understood this, and his calling language a human institution is very shallow."

At a subsequent period of the same year appeared vol. iv. of Mr. Müller's *Chips from a German Workshop*, in which, in addition to the reply to Darwin, there is an article entitled, "In Self-defence—Present state of Scientific Studies," calling attention to the difficulties of the evolutionist theory, and further explaining his own views. In the course of his argument he quotes Professor Prantl, of Munich, on the essential unity of thought and language, as follows:—

"Realised thought, or, what others might call the realisation of the faculty of thought, exists in language only, and, *vice versâ*, every element of language contains thought. Every kind of priority of real thought before its expression in language, is to be denied, as well as any separate existence of thought."

The controversy, by this time, had grown rather warm, and perhaps it was as well that it was carried no further. Professor Steinthal, of Berlin, had had a previous encounter with Professor Whitney, a specimen of which is quoted by Mr. Müller. It reminds one more of the time of Milton and Salmasius than of the courtesy of modern times. Steinthal calls his opponent "a horrible humbug;" "a tricky attorney;" "a scolding flirt." "Whenever I read him, arrogant vanity grins at me."

Where such irreconcilable differences exist between learned professors and high authorities on a subject of interest, both historical, ethnological, and scientific, it appears presumptuous to offer any suggestions; but in some of its aspects the dispute almost reminds one of the contest *à outrance* of the knights as to the shield, whether it was gold or silver, without examining if it might not have two sides. Much depends on the meaning of the terms employed. There seems at one point a very close approximation between the two schools. Professor Müller attributes to animals "perception, memory, will, and judgment," but denies them reason. Dr. Brown asserts that the marks of reasoning in the inferior animals are unquestionable. Now, what is the difference between reason and judgment? Kant, in his *Critique of True Reason*, says, "Sense delivers up its presentations in space and time to the understanding, whose office it is to introduce into them unity and system. This is done by the faculty of *judgment*, which combines the multi-form data of sense in the unity of propositions." Judgment must act by comparison, coming to a conclusion by the examination of evidence. If, then, animals possess this faculty, it seems hard to deny them the possession of thought in its primary elements. If a dog scratches for admission at the front door, and, finding no entrance, goes round to the back, there must be the memory of two things — a comparison between them and a conclusion drawn. If reason be limited to the power of combining ideas and forming abstract conceptions, undoubtedly it is not possessed by brutes; and here seems to be the impassable barrier between man and beast. The combination of ideas derived from perception requires symbols of some kind, but not necessarily those of articulate speech. It is probably true that without language there would have been no power of forming such general ideas; but, once formed, other symbols may be used with

equal effect. The case of deaf mutes is often alluded to. Mr. Müller says, "The deaf and dumb are taught to think the thoughts of others, and if they cannot pronounce their words, they lay hold of these thoughts by signs that appeal to their sense of sight. These signs, however, are not the signs of things or their conceptions as words are; they are the signs of signs, just as written language is not an image of thought, but of the phonetic embodiment of thought." This seems a very extraordinary statement. Does the Professor mean to say that when a deaf mute expresses in the language of signs that he has seen a horse or a camel, the gesture does not refer directly to the animal, but to a sound which he never heard and has not the slightest idea of? In combining concrete ideas so as to form general notions, the phonetic symbol has to be supplanted by a gesture; but it is just as much a direct symbol as the phonetic sign for which it is a substitute.

The inference from the whole appears to be, that as language is the expression of thought, thought, in its perceptive form, must precede language; but in forming general ideas, where combination and comparison are required, the mind cannot proceed without symbols, which are furnished primarily by articulate speech alone.

I fear that I have somewhat tired your patience by the length of this Address, notwithstanding the very brief glance I have been able to devote to many parts of the subject, which it would have been interesting to dwell upon.

The study of language as a science has hardly half a century to look back upon. Within that short period it has made wonderful progress, and some of the keenest intellects of the age have devoted themselves to its elucidation. Every year brings fresh triumphs, and discovers law and order in departments formerly considered abandoned to irregularity

and confusion. Language is the link which unites soul with sense, the gift which distinguishes man from the brute, which enables him to hold communion with his fellows, and confers the power of combination which is essential to all progress. The fairy visions of the poet, the profound speculations of the philosopher, the thrilling and exciting periods of the orator are couched in language. From the childish syllables lisped at a mother's knee, through all the changing scenes of life to the last whisper of the departing soul, all our intercourse is carried on in language. Whatever progress the world is to make in the future, it is language which will give the impulse. If a new dawn is to arise upon humanity, and the thick mist of ignorance is to be dissipated, even by a rude disturbance of the mental and moral atmosphere, it is language which will be the instrument —

“ For all the past of time reveals
A bridal dawn of thunder peals
Wherever thought hath wedded fact.”

ON HAECKEL'S HISTORY OF CREATION.*

By ALBERT J. MOTT.

THE materialistic philosophy of the present day is not often presented to mankind in a perfected form. The more prudent among its teachers commonly avoid its ultimate results, or exhibit them in the hazy shape which allows the imagination to conceive what it will behind them. Sometimes, doubtless, this is done of set purpose by men who are perfectly aware of what the haze conceals, but more often it is the effect of an instinctive wish to see no farther, and to indulge the old hopes of a former faith after its beliefs have been abandoned. In either case there is a want of courage on the teacher's part which deserves no real respect, except so far as it represents the protest of his nature against his teaching, and the man who, having adopted a theory, insists on its necessary consequences and boldly faces them, does far more service to the world. Such a man emphatically is Professor Haeckel of Jena, the translation of whose work on the *History of Creation* gives to most Englishmen the fullest opportunity they have yet enjoyed of understanding what the complete doctrine of Development, as applied to life, really means, what is really involved in it, and on what grounds of evidence its truth is maintained. In treating of this subject, Haeckel is a man absolutely without a fear. Believing in no personal creator, in no human identity apart from that of the material organism of the moment, in no future life except that of the race, he is one of the few who find themselves perfectly content with this position and this prospect.

* *The History of Creation.* By Ernst Haeckel, Professor in the University at Jena. Translation revised by Professor E. Ray Lankester, M.A., F.R.S. 2 vols. London, 1876.

It gives him the highest satisfaction to feel sure that no living being in the universe cares one straw what becomes of him, except himself and his human friends; that the whole creation is absolutely without a purpose or a plan;* that it is bound by laws which act without an object, exist without a reason, and produce things only stronger or weaker, of which the stronger get the upper hand; that the highest happiness of man† consists in the intellectual enjoyment of this iron-bound nature, and his highest aim, in the knowledge of these irrational laws; that "highest" in this, as in all other cases, means nothing at all but greatest in quantity or strongest in act, and that to seek or care for anything besides is to mistake for fact what is a mere illusion of the mind.

Setting to work with these views and this feeling, he is, of course, unfettered by any latent doubts, or scruples, or regrets in expounding as complete a theory as he can devise. He does, accordingly, in the most earnest manner, pursue the doctrine of Evolution to its extremest consequences, and he insists on their acceptance as necessary deductions from those partial and really inconsistent views of it which many are fain to hold. In this, his argument is generally unanswerable. He shows that there is no such intermediate stopping-place as timid evolutionists are anxious to find. He fails, of course, and it is marvellous that he does not see it, in excluding purpose and plan from nature by supposing the universe to consist of nothing but matter governed by unchanging laws. Professor Huxley, in his friendly criticism of Haeckel's German work, has pointed out this error. But it is not in the direction of atheism that the gravest consequences of the theory show themselves. It is the credibility of a life hereafter that is really destroyed by it, if it be true at all, in Haeckel's sense. If the highest beings have been developed from the lowest, by merely material

* Vol. i., p. 20. † Vol. i., p. 36.

additions and alterations, we ourselves are nothing but protozoa, thus added to and thus altered. Our conscious identity, and all that we call our souls, belong to this special matter in this special combination, and no sort of personal existence apart from it, and no continuance of identity after the combination is once destroyed, can be conceived of as possible. This fatal consequence is the grave difficulty in the path of modern evolutionism, as now embodied in the teaching of the leaders of scientific thought. To men like Haeckel, it is to be met simply by accepting it as a truth, and thinking no more about it. Life in this world, they say, is sufficient for us. Let us make the most of it while it lasts. But to the majority of mankind it is not sufficient, nor is it possible to make the most of it without the hope of a life to come. Hence the various efforts to preserve some ground for such a hope, notwithstanding the logic of the evolution theory. Some, indeed, are satisfied by a simple trust in supernatural power, as able under any circumstances to fulfil the promise upon which Christians have so long relied; but the keener sighted perceive that all the evidence of that promise, and all the reason for that trust, are really swept away by a theory which makes mind itself the mere passing product of the clash of atoms. Some endeavour to escape the difficulty by appealing to the indefinite possibilities lying hidden in the vast region of the unknown; some take refuge in the idea that, while the ancestors of mankind were perishable beasts, a living soul was given to the race when a fitting bodily form had been developed.

I cannot share in the belief that the deepest feelings of human nature will ever find real content in any such compromises between science and religion. The complete doctrine of evolution, as laid bare in Haeckel's volumes, involves a sentence of eternal death upon ourselves, and the feelings

which revolt from such a conclusion should lead us, not to evade it, but to examine afresh, with perfect honesty, but with critical suspicion, the pretensions of a doctrine which has grown up so suddenly, and which threatens us with consequences so tremendous.

I believe we shall find in this, as in so many similar cases, a foundation of most important truth, with a superstructure of most injurious error; the truth being the discovery of sound scientific thought; the error, the result of speculative theory and unphilosophic generalisation.

The doctrine of Evolution, as commonly understood, and as expounded by Haeckel, supposes that each of the chief forms of life, except the lowest, has been developed from some other form lower than itself. It supposes, therefore, that progressive forms, in a continued series, have succeeded each other in time; the lower ones existing first, and the higher ones coming into existence afterwards. The doctrine cannot possibly be true unless this is true; nor can it be really established while there is any remaining doubt upon this point. The earlier discoveries of geology seemed to leave no doubt, for it was clear that only the fossils of low forms of life had been found in the oldest rocks, and that higher forms had been met with successively in newer rocks, and the relation between the actual life of any period and its geological record was not then understood. But later knowledge has destroyed the seeming validity of this evidence, by continually putting back the date at which the earliest examples of each particular form are severally found, and by the appreciation of other reasons, besides that of successive appearance in time, which make it certain that we must always find less of the higher and more of the lower forms as we go deeper down into the crust of the earth. The first crude ideas have, however, held their ground. Their truth,

as facts established by geology, is still very generally taken for granted to an extent which is not to the credit of modern science, and is assumed by Haeckel in a manner which cannot be too strongly condemned in a writer of recognised authority, whose judgments are supposed to rest on evidence, and not upon mere fancy, seized on to support a theory.

* "The five great main divisions of the organic history of the earth," says Haeckel, "we call the primordial, primary, secondary, tertiary, and quaternary epochs. Each is distinctly characterised by the predominating development of certain animal and vegetable groups in it."

This statement, of course, supposes that we know which groups of animals and vegetables really "predominated" on the earth during each of these epochs. But we have no such knowledge, nor any means of obtaining it, as Haeckel himself shows in the next two pages, where he states the indisputable fact that, in the seventy thousand feet in thickness of the Laurentian, Cambrian, and Silurian systems, a thickness which, in his belief, required many thousands of millions of years for its deposition, by far the largest portion is in that metamorphic state in which no fossil forms can be recognised. Yet, on the few remains which have been found here and there, as the sole organic records of this vast period, he ventures to settle the question of life on the earth with as much confidence as if he saw it all before his eyes.

† "What seems to be shown by them," he says, "is that, during the whole of this immense period, there existed only inhabitants of the waters. As yet, at any rate, among all archilithic petrifications, not a single one has been found which can with certainty be regarded as an organism which has lived on land."

* Vol. ii., p. 8. † Vol. ii., p. 10.

But who expects to find organisms which have lived on land at the bottom of the ocean? and where could these great beds be formed except at the bottom of the ocean? and if land plants and animals are indeed occasionally buried in some portions of marine deposits; near the mouths of rivers, for example, and along coast lines, where gradual subsidence is taking place; what is our chance of finding them, with human means of research, when we know that every trace of organism of every kind has been obliterated from by far the largest part of the entire mass of strata? Yet, because they have not been found where little less than a miracle could have placed and preserved them, "it seems to be shown," says Haeckel, "that during the whole of this immense period there existed only inhabitants of the waters."

This is neither science nor even common sense; and when the University of Jena, or any other seat of learning, commits itself to reasoning of this kind, it forfeits all claim to confidence as a safe guide to the students of Nature.

What not only "seems to be shown," but is positively demonstrated, by the facts adduced, is that we can learn nothing whatever concerning the existence or non-existence of land organisms, during the period in question, from the mere examination of such fossils as have been found. If a naturalist should go to Africa in search of polar bears, and, finding none, should gravely argue that the race was evidently extinct, we should make short work of him as a scientific authority. There is no reason why we should deal more leniently with those who, searching among the rocks of old sea bottoms, declare that no land animals existed, because no remains of them have been discovered there.

The "predominating groups" assigned to each of the

four succeeding divisions of geological time, by Haeckel, are determined in the same way, on the same false premises; the assumption throughout, that what has not been discovered in a fossil form has not existed in a living state; coupled with an equally astounding assumption of the very opposite kind when his theories require it. He actually proposes to name his great primordial epoch, of several thousand million years' duration, after the Acrania, of which no sort of vestige has been found, on the mere supposition that they *must* have lived then in great numbers, because the fishes of the next age *must* have been developed out of them !*

It is difficult to read such passages with patience, and it is high time that they should be treated as they deserve.

It must be affirmed, once for all, that, with our present knowledge, the character of the life existing at any former period cannot be established by negative evidence; and, if there were nothing else to appeal to, the question, Whether its highest forms existed in the earliest epochs, or whether they appeared successively in the course of time, would have to remain unsettled, and, in fact, insoluble.

I believe, however, that a sound answer may be given to it by rigorous induction from facts that we are able to observe, and I propose to lay before you what seem to me conclusive reasons for believing that animal life was as abundant and as varied in the earliest period known to us as it is at the present day; that all its typical forms existed then; and that this is not only confirmed by our latest knowledge concerning the earth's physical history, but is the only view entirely consistent with it. If this can be established, the basis of Haeckel's system will disappear.

It is certain that the old ideas about species were entirely

* Vol. ii., p. 11.

mistaken; that the essential differences between the forms of living things are not what we formerly supposed. It is a fact that all organisms have a tendency to alter their forms in various directions, and to transmit these alterations to their offspring; and it is a fact that the struggle for existence causes certain forms to survive while others perish. It follows that if we can trace back the pedigree of any creature now living, we are certain to find that its distant ancestors were not exactly like itself. And it follows, also, that we are not, so far, in a condition to say beforehand how much or how little they resembled it. The history of living things, therefore, has been a history of continued variation of form; the prevailing forms of any particular epoch being those, among all that the epoch had produced, which were best fitted to survive under the circumstances. This is Darwin's great discovery; the truth of which is no longer matter of debate.

But the first question which arises, before any further step can be taken, is clearly this: Is the tendency to vary a limited or an unlimited one? Can any form of life change by degrees into any other; or is there any definite law of change, either as to degree or direction?

Now, modern science gives no satisfactory answer to this enquiry, and the reason is obvious. We know that living things grow, but do not know why they grow; we know that they vary their forms, but do not know why they vary them. This total ignorance as to the cause makes it impossible to determine anything as to the effect by a deductive process, and our observation of what actually occurs is in its nature far too limited for any general induction. The consequence is, that whenever the derivation of one form of life from another form is affirmed, the preliminary question, Whether

this is possible to begin with, receives no scientific answer, even in the simplest cases, except so far as the fact has been observed. When, for example, it is asserted that birds are the lineal descendants of reptilian animals, it is not difficult to point out the changes in form and function that would have been required, or to conceive a process of gradual variation by which these changes might have been slowly brought about, without producing any form of life which appears to us impossible, in any of its stages. But whether the continuance of such a process from such an origin is itself a possible thing, can only be determined in one of three ways. Either the fact itself must be observed; or observation of other similar facts must establish an empirical law which applies to the whole case; or the causes at work must be so far understood that we can say with certainty they are sufficient for the purpose.

Now, the fact has not been observed, nor is it pretended that we know the causes of variation; and as to the laws, if any, by which their action is limited, our ignorance is equally profound.

When the germ of a reptilian egg grows into its own special form of life, some cause is acting, of which this is the effect. We know that that cause, whatever it may be, is able to produce from this germ a living creature somewhat different from its parents, and we know that this living creature, through succeeding generations, may be the ancestor of others, each exhibiting some kind of variation. If this power of variation, in a line of lineal descent, has no limits, then, of course, any living creature may, in the course of time, have any other form of life among its direct descendants. But if it has any limits, then the possibilities of the case are absolutely determined by them.

This question, so vital to the Evolution theory, has never been grappled with by its supporters. In practice, the fact

of limitation in the power of varying is alternately affirmed and denied by them. It is denied when the lowest form of life is supposed to be the origin of all other forms. It is affirmed when the possibility of the opposite process is set aside. It is further affirmed in a vast number of particular cases. It is not believed, for example, that a perfect reptile could be the ancestor of birds, or a perfect bird of mammals, or a perfect ape of men. It is not supposed that any future descendants of the horse will have wings, or that shell-fish of some other age will trace back their pedigree to eagles. Yet the admission of these various limits lays a prodigious weight upon those who undertake to prove that all limitation is removed, if you only begin low enough; if you take the living powers of a bit of shapeless jelly as the originating cause of every form of life.

Nor is the question answered in the least degree by the discovery of any number of what are called transitional forms. If there is any line which cannot really be crossed, you do not bridge it over by laying stones close to each side of it. Show, as a matter of fact, that the form you call transitional has an ancestor on one side and a descendant on the other, and you settle the question as to whether the first *can* produce the transitional form, and the second be produced by it. But show only that the three forms exist, or have existed, and nothing is settled concerning their relationship. Each one of them, for anything you know, may have had an independent ancestry, from which it may have been quite impossible that either of the other forms could have been produced. Take two similar plants of the same species. Grow them under the same conditions, but propagate them separately. After several generations, each plant will have descendants differing slightly from itself. The two families will also differ slightly from each other, and, by choosing out

those that differed most, and then taking individuals, some from one family and some from another, you could readily show a complete series of very small variations, leading up from one extreme to the other. Yet each family would, in fact, have followed an independent course of variation. No individual of one family would have had its exact counterpart in the other, and the reason why the transitional series appeared so perfect, while, in fact, two independent pedigrees were included in it, would be simply because the individual differences were very small. Small as they were, however, they constituted impassable distinctions. The offspring of the one parent could never be exactly like any of the offspring of the other. At the same time, some of them would probably be as much alike as the original parents were, and from these a similar process could be repeated.

What is true of individuals would be equally so of groups. If any group, as is generally the case with those which we distinguish as species, continued to propagate itself without mixing with others, a certain amount of variation would occur in the course of several generations. The same thing would happen in the species most like it; and, again, a series of apparently successive changes, from the generic forms in which the two species originally agreed, to any of the extremes of divergence from them, could be made by taking individuals from both lines of descent.

No one doubts that the power of variation, in such cases, is so far limited that whatever changes occurred in one of these lines, the same changes exactly could not occur in the other.

But if at the end of, say, ten generations a certain change of form is established, the successive forms of the nine previous generations are the real transitional forms through which the change has been arrived at, and no other forms, nor any other order of succession, could lead to the self-same result, however closely they might resemble these.

It is equally certain that in the two lines of descent supposed, the successive forms in each line would resemble each other so closely that we could not separate them with any degree of certainty if they were mixed.

Again, we see that the real transitional nature of any form cannot be ascertained by mere comparison with other forms, between which it appears to be the connecting link; and that the smallest differences may, nevertheless, be lines of limitation which could never have been passed.

It follows, therefore, that if in this or any previous age we find a bird, for example, very nearly like a reptile, and a reptile very nearly like a bird, we have, nevertheless, found nothing which really indicates any necessary connexion between them in any part of their pedigree. Each line of descent may have extended back indefinitely, with a constant difference from the other line which could never be effaced.

It follows, further, that if at any former epoch the world was filled with life, in as much abundance and as great variety as now; if earth, air, and water swarmed, as now, with suitable inhabitants; if every known type of visible organisation, from the simplest to the most complex, was fully represented, let us say in the Laurentian period; the condition of things as we find them at the present day would be only the natural and apparently the necessary consequence. Each line of continuous descent would have produced a series of variations, the direction and the limits of which would in each case be determined primarily by the nature of the individual at the head of the pedigree. No individual now would be exactly like his distant progenitor; and where the differences between individuals were small, it would often be impossible to say to which line of descent either of them really belonged. Many families would have died out in the course of ages. Many others would have multiplied them-

selves into several divergent branches, differing from one another as much, and not more than the previously existing families had differed, but never producing the same thing exactly a second time.

Well, this is the real history of life, as far as we fully know it.

Geology gives a tolerably complete account of it during the recent period—using the word recent in a general, not a technical, sense. As long as this account is thus complete,—as far back as there are abundant records of what happened on land and water, in all their various conditions,—we know that life existed everywhere and in all typical forms. But as the view recedes, and we look further into the past, the records become continually more fragmentary, and the history of the land passes very rapidly out of sight. At last we have nothing left but the history of the water, and, finally, scarcely anything but that of the deep sea. Of course, our knowledge of life, as a whole, diminishes in the same degree, but we still find equal abundance and variety wherever the record gives a full account of it in any one direction.

Supposing this to be true throughout, it is obvious that we can get no nearer in this way to any knowledge of a common ancestry for existing forms of life. We shall only find the present types existing at the most distant period to which the world's history can be traced; and, following their lines of descent, we shall notice a constant variation in details, but a constant resemblance in essential characters. And the conclusion will be unavoidable, that the power of variation explains the changes that are known to have occurred, but cannot explain the origin of those essential characters which are not known to have been changed. And, consequently, that variation, so far as our knowledge extends along the direct line of descent from any individual parent, is the

result of a distinctly limited power, and that any difference, however small, which lies beyond this limit, can never be arrived at by the descendants of that individual.

But neither the nature nor the cause of the limit are known to us, and we can never say, therefore, whether or not a particular change could occur in a particular pedigree, except so far as a practical law of change has been established by actual observation.

What, then, are the means of observation by which any such laws can be established? It is here that we come face to face with Haeckel's entire system, which is, indeed, nothing but the Darwinian theory, combined with the general doctrine of Evolution, and both laid bare to the roots. We must begin at the beginning to get any clear notion of the ground on which it rests.

Haeckel begins, naturally enough, with the nebular hypothesis, and takes for granted that this is true. The world, therefore, was once a molten mass, which has gradually cooled. It was, therefore, much hotter in the Laurentian period than it has ever been since. The atmosphere was also different, and the earth was not yet fit for organic life, except in the sea. The only animals were protozoa, and the only plants algæ.

Such a beginning leaves only two alternatives in accounting for the rest. Either subsequent organisms must have been created, or they must have grown out of the primeval ones. The idea of creation being too absurd to think of, in Haeckel's view, the other alternative alone remains, and protozoa and algæ are necessarily the ancestors of all other living things. As even these have to be accounted for, and as they could not form part of the original nebulous mass, inorganic matter is supposed to have produced them by some

mechanical change in its molecular motion, on the cooling of the earth's crust.

Thus we have a fair start, always granting the nebular matter, and the forces found therein.

The propagation of life from generation to generation is subject to the two great laws of inheritance and adaptation. The general characters of the parent always are, and the special characters always may be, inherited by the offspring. During the life of an organism, every part of it has a tendency to vary in such a way as to adapt itself to the conditions by which it is surrounded. Every parent becomes more or less modified in this way, and transmits more or less of the same modification to the form of its offspring. This power of adaptation is unlimited, according to Haeckel,* *except* in the essential fundamental qualities of the "type" to which the individual belongs; and these original types are themselves the earliest forms of variation which arose in the first and simplest form of organic life.

Thus we have first a nebulous mass; then a world too hot for life, but gradually cooling; then, at a given point in temperature, the production of the first organism by chemical action among the inorganic elements; then a constant change of external conditions, with a constant adaptation of organic forms, through variation, inheritance, and natural selection of the fittest, and thus the successive development of all living things.

The theory is complete in itself; but what are the real grounds we have for believing it to be true?

We must first observe that, if the theory is to stand at all as a philosophy of life, no part of it can be dispensed

* Vol. i., p. 250.

with. If all living forms are derived from a primeval organism, that organism must be itself accounted for. If it is accounted for as the result of special chemical action at a particular period, there must be a reason for that action.

If the reason is found in the cooling of a heated globe, the production of such a globe must be explained. The materialist may reasonably stop here, and maintain that, as far as life is concerned, he has gone back far enough when he has traced its causes to the mechanical and chemical forces by which a nebulous mass becomes a world. But he cannot stop sooner, without leaving the field equally open for any other hypothesis concerning the origin of living things.

The nebular hypothesis is therefore the foundation of Haeckel's system. Its truth is commonly taken for granted; but, as a matter of fact, there is no real evidence to sustain it, while there are grave objections which cannot be removed.

All we know about it is, that the formation of a system of revolving bodies, on the general plan of the solar system, out of a nebulous mass acted on by gravity, is mathematically possible under conditions which can be named. But we do not know whether it is physically possible, or whether the needful conditions ever have existed, or could exist.*

This is sufficient to remove it from the sphere of scientific knowledge to that of mere speculation; and, as the hypothesis is important in Haeckel's system, chiefly because it gives him a molten world gradually cooling, while I shall show independent grounds for rejecting this idea, so far as the history of our planet is known, I pass on now to the geological evidence on the subject of evolution, which has been strangely misinterpreted.

It is quite certain that in the Laurentian period the surface temperature of the earth was substantially the same

* See Note A.

as now ; for there was land and water, and there were plants and animals. It is equally certain that the temperature of the crust was similar to the present temperature for a depth of several miles, for the deposits of that period have been upheaved from that depth, and they have not been acted on by heat of an exceptional kind. It is improbable that this could be the case if the earth had really been cooling through that enormous length of time.

The fact that rocks which have been melted are found under those of the oldest sedimentary kind, gives no support to the theory, for we only know this where the sedimentary rocks have been upheaved ; and, as their upheaval has either been caused by volcanic action, or, at all events, associated with it, we expect to find evidence of such action underneath them ; and the natural evidence is found in molten rock, and molten rock of quite similar character is known to have been produced in recent times.

It is certain, as already stated, that in the Laurentian period the earth's surface consisted, as now, of both land and water ; that rain fell, and that it was carried by rivers to the sea. This is proved by the deposits themselves.

Sedimentary beds, formed slowly in vast periods of time, can only be formed by the constant conveyance of fresh material into the seas of which they compose the bottom.

This is equally true whether they subside from mechanical suspension in the water, or are the result of its evaporation, or, as is generally the case, have their origin in organic life.

No seas could hold at one time, either in suspension or solution, more than the merest fraction of those enormous beds which have, in fact, been deposited.

The material, therefore, has been brought by a process as gradual and as continuous as its deposition, and there is no reasonable explanation of such a process, except the common

sense one of rain and rivers. But this carries back still further the uniformity of the earth's general state and general temperature, for the existence of the same condition of things upon its surface involves the pre-existence of similar causes.

The Laurentian rocks differ from recent ones in nothing that is not the natural result of time. They give no indication of material derived from other sources, or by other means, than those now existent. But observe the inevitable inference, which is entirely overlooked by writers of Hæckel's school.

The largest sedimentary deposits in the known crust of the earth owe their origin, not to mechanical, but to vital operations.

The only important sedimentary beds, the formation of which is independent of vegetable or animal life, are those produced by the action of waves on coast lines; by inundations of the land; by rivers, about their mouths, and by the drifting of ice. These are often of great thickness, but they are necessarily of limited extent. The really vast beds have been formed over large areas of sea bottom, and the conveyance and deposit of the material both involve the aid of organic life.

The material thus diffused over wide oceanic spaces does not come in mechanical suspension, but dissolved in the water; and the great solvent power which rain exerts depends on its passing slowly through pulverised and porous soil, in which it meets the earthy elements in a condition favourable to solution, and remains long in contact with them and with the harder rocks, upon which they hold it like a sponge.

It depends also on the absorption of carbonic acid and other gases which are formed by the decay of organic matter in this spongy surface. The soil itself is chiefly the result of

organic decomposition, and of the action of living plants upon inorganic matter.

This is the way in which earthy materials come to be dissolved and carried to the sea ; and it is only when thus dissolved that they go in large quantity to any distance from the land, and are capable of being deposited again over great sea-beds. The mud brought by rivers, in mechanical suspension only, falls to the bottom, near their mouths. The cases are rare in which it is carried in any quantity more than two or three hundred miles from land.

And, as organic action has been necessary, in order to get the material thus dissolved in the water, it is needed again to get it out of it. Constant evaporation from the surface of the sea, and the constant return of part of the water with earthy matter in solution, would end at last in a saturated ocean, from which any further additions would be precipitated. But such an ocean can never have existed, for it would have remained saturated with soluble matter, and would in that state have been unfit for the support of life at any future time.

The present seas are not saturated with any substance whatever.

Saturation never takes place, because the soluble matter brought by every river to the sea is there extracted from the water by living organisms, and then deposited afresh upon the ocean bed in the various forms of animal and vegetable waste, and the products of its decomposition and disintegration.

The power of living organisms to select, and so to aggregate, particular materials contained in mixed solutions, and to break up chemical combinations by extracting certain of their elements, is perfectly established.

That this is the true origin of most of the sedimentary rocks, and that mere mechanical subsidence of undissolved

matter plays only a secondary part in their formation, has become more and more certain as our knowledge has increased, and the cruise of the *Challenger* has confirmed this general principle in the strongest way.

The proportions in which the various elements are found in different strata; the order of their deposition; the mode of their distribution; the localisation of the rarer kinds, such as many of the metals, all of which doubtless exist in sea water, while they are only extracted from it and rendered capable of deposition by special organisms; all these most important and interesting facts will probably be explained hereafter by further knowledge of the operations of life.

On a careful view of the matter, therefore, it appears that our knowledge of sedimentary strata is the knowledge of rocks which required generally for their formation the joint action of plants on the land and animals in the sea.

But this includes the whole history of the earth's crust, as far as geology can trace it; and we find ourselves obliged to suppose the world, at the beginning of the Laurentian period, in a condition of which the main features cannot be distinguished from those of its present state.

And not only this. We get no explanation whatever of the mode in which that condition was arrived at, nor do we find a single indication of any nearer approach to a molten or an uninhabited earth. The Laurentian continents, out of which the rocks of the next period were formed in the Laurentian seas, were themselves raised from ocean bottoms, where they also had been formed from materials brought from previous continents of a similar kind. One vast epoch rises behind another in endless series, and nothing that we have real knowledge about shows us the way in which a world

cooling from incandescence could form itself into a world like this.

The close interdependence of the different parts of the organic world makes any hypothesis which dispenses with any of them in any former period at least a dangerous one, for our experience is limited to a world in which they mutually support each other; and it is always doubtful whether we can correctly conceive the results of parting with any one of them.

Now, the relation between plants and animals is at present of the most intimate and complex kind.

There is a common notion that, as a necessary condition of life, animals require plants, but plants require only inorganic materials.

Yet, as a matter of fact, animals give to plants at least as much assistance as they receive from them. The first thing necessary to vegetable life is a supply of carbonic acid in the air, and one of the daily sources of this supply is the oxidation of carbon in the bodies of living animals.

Human beings, on an average, exhale at least one hundred pounds weight of carbon, in the form of carbonic acid, annually, for each person, or at least fifty million tons per annum from the whole human family. This is sufficient for the formation of twice that weight of dry vegetable matter; and if the annual product of the soil is estimated at about three tons per acre, or two thousand tons per square mile, the whole vegetable product of fifty thousand square miles, which is the area of England, is provided for by the carbon oxidised in the bodies of the human race alone.

The number of the larger mammals, including horses, cattle, sheep and pigs, is, in England and France, about four hundred to the square mile. If this were the general average, these animals would be about twenty times as numerous as the

human race. The average amount of carbonic acid exhaled by them must exceed that of an equal number of men; and, though no general census of the large mammalia can be taken, their great importance in the supply of this essential gas is beyond dispute. If we then consider the multitude of other animals in the world; the swarms of the smaller mammalia; the myriads of birds; the incalculable extent of insect life; and if we add to this the animal products of the ocean, where, if oxidation is slow, the agents employed are in number beyond all arithmetical expression, we must feel immediately that, whatever other sources may supply carbonic acid to the atmosphere, the quantity furnished by living animals is so enormous, that without it the present growth of vegetation could not take place.

Besides carbonic acid, a certain quantity of nitrogen is indispensable to the growth of plants. Whether inorganic chemistry is the primary source of the supply, is undetermined, but it is certain that animals provide nitrogenous compounds in the form best suited for assimilation by plants more rapidly than the natural decomposition of vegetable matter would produce them. The supply of nitrogen, therefore, in these forms would at least be reduced if there were no animals.*

Still further, the soil in which land plants flourish is loosened and pulverised to an incalculable degree by worms, larvæ, and other burrowing animals, without the aid of which its power of absorbing moisture, and its suitability for receiving and nourishing the roots of plants, would be to a great extent destroyed.

It appears, therefore, that even if vegetation could continue to exist at all, for any long period, without the aid of animal life, in its present varied forms, it would do

* It appears probable that even lichens cannot live without the help of organic matter already in the air. See *Nature*, No. 370, p. 109. Prof. Calderon's experiments.

so under such disadvantages, that it would be contrary to reason to believe that any approach to the present luxuriance of vegetable growth could be maintained.

Proofs of abundant terrestrial vegetation in the palæozoic rocks are therefore the strongest evidence in favour of an equally abundant fauna co-existing on the land.

The notion that an atmosphere highly charged with carbonic acid gas is required to explain the coal deposits of the carboniferous era, is one of those fictions of the imagination which encourage a belief that facts are accounted for in a manner agreeing with our theories, when they have really not been examined with care.

A large excess of carbonic acid gas in the air during the earlier epochs of a cooling earth, and an extraordinary development of plant life before the advent of animals, would suit the common theories of evolution; and it is convenient, therefore, to assume them as facts.

But the proportion of carbonic acid now in the air, if constantly maintained, is sufficient for the most luxuriant vegetable growth of which we have any indication, past or present; and the total quantity of vegetable carbon now in the ground prodigiously exceeds the utmost that could ever have been in the atmosphere at any one time since the first sedimentary rocks were formed. It is in the sources from which carbonic acid is continuously supplied, and not in its pre-existence in overwhelming quantity, that we must seek the history of the carboniferous deposits beneath our feet.

The luxuriance of vegetable growth depends primarily upon temperature, moisture, permeability of soil, and the supply there of various substances in a soluble form. It is variations in these, and not in the supply of carbonic acid, which is the same everywhere, that make at present all the

difference between a tropical jungle and a sandy desert. Of course, there must be, as there is now, sufficient carbonic acid, or there will be no vegetation ; but that condition being satisfied, the amount of vegetation is determined now by the causes above enumerated. And where the circumstances are favourable, the present rate of production, with the present atmosphere, is quite as great as there are any reasons for supposing it to have been in any former times.

Sir William Thomson calculates that the amount of dry vegetable matter produced annually in a German fir-wood, is equal to about one pound on every ten square feet of surface.* If one-half of this were deposited as coal, it would be equal to a layer about a yard thick in five thousand years. Now, the produce of the tropics is probably several times as great as that of a fir-wood in Germany. So that it is clearly possible for vegetation, growing in the present atmosphere, and under existing conditions, to produce a bed of vegetable matter, equal to a seam of coal a foot thick, in a few centuries. There is nothing whatever to make us believe that any of the known coal fields were deposited more rapidly ; and the theory of a more abundant growth of plants, in an atmosphere more highly charged with carbonic acid, in former times, is, in fact, without a vestige of foundation.

I am brought, here, to a subject of extreme interest and importance, which attracted the notice of Liebig, and still more of Bischof, but which, I venture to think, has been misinterpreted, partly through theoretical prejudice, and partly through the want of definite information, which has only been very recently supplied.

Carboniferous deposits are, without doubt, deposits chiefly of vegetable matter, grown on the surface of the earth.

* *Philosophical Magazine*, vol. 4., 4th series, 1852, pp. 256-260.

Plants so growing derive their carbon from the atmosphere. The atmosphere contains a certain quantity of carbon in the form of carbonic acid, and the quantity varies only within narrow limits. We know that it can never have been much greater than at present while animal life has been abundant, because it is found, by experiment, that a small addition is injurious and a larger one fatal to animal life; and it can never have been much less while vegetation flourished, or there would have been an insufficient supply. The proportion, therefore, has been about the same as at present for an indefinite length of time, which we might call a million years, with the assurance that this is really only a small fraction of the truth.

Plants decompose carbonic acid, and give back its oxygen to the air. Thirty-two pounds of oxygen are thus given to the atmosphere for every twelve pounds of carbon thus withdrawn from it. Nevertheless, the quantity of oxygen cannot have varied much while there have been living animals, as we know by observing the effect of its increase or diminution.

The destination of vegetable matter is twofold. Part of it becomes the food of animals; part of it falls upon the ground. Most of the carbon in the food of animals is reconverted into carbonic acid and restored to the air; but of vegetable matter falling on the ground, a great part of the carbon remains there. The various kinds of decomposition to which vegetable matter is subject, leave ultimately from one-third to nine-tenths of its carbon, according to Bischof, which is not oxidisable at common temperatures by ordinary natural processes. On an average, it may be assumed that two-thirds of the carbon falling on the ground remains there as a permanent deposit.

The average annual growth of dry vegetable matter in

Germany, as reckoned by Sir William Thomson and by Liebig, is equal to about two tons per acre; but much higher estimates have been made, and, allowing for the rapid growth of warmer countries, as well as for the roots of plants, it will be safe to consider two thousand tons per square mile, or about three tons per acre, as the general average on the earth's land area of fifty million square miles. These estimates, it must be borne in mind, are all made upon measured quantities, taken after the wants of the animal world have been, to a large extent, supplied; for animals live chiefly on the growing parts of plants, and the quantities reckoned as produced are measured after the plants have grown and have been cut down by man. It is not likely that nearly one-half of this residual portion is consumed afterwards as food; but if we allow one-half, it will follow that one thousand tons per square mile return annually to the ground. Of this, nearly half is carbon, and if two-thirds of the carbon remains unaffected by decomposing action on the surface, the final result will be the deposit of three hundred tons of carbon per square mile, or fifteen thousand million tons per annum.

There remains the vast ocean area of one hundred and fifty million square miles, on which abundant vegetation, subject to similar laws, continually grows, and where the deposit of carbon from the exuberant animal life of the waters must also take place on a prodigious scale. There are no data by which the actual quantity can be calculated, and I omit it altogether, as a special and, doubtless, a far more than sufficient security against over-estimates.

The total quantity of carbon always existing in the present atmosphere is about one billion tons, and the total quantity of oxygen is one thousand times as great.

It follows that a quantity equal to all the carbon is extracted from the air and deposited in the ground in seventy

years; while, in about twenty-five thousand years, the oxygen thus restored to the atmosphere is equal to the whole quantity which it now contains.

It follows, further, that in one million years, the quantity of carbon deposited in the ground would be fifteen thousand billion tons, and the quantity of oxygen restored to the air would be eight times the volume of the entire atmosphere.

These figures are sufficiently striking, but I must still call your attention to others not less remarkable.

Liebig supposed that the carbon in the atmosphere was equal in quantity to that of all the coal in the world. Bischof perceived that this must be an error, and has made some striking remarks upon the subject. But the elaborate statistics, and careful estimates of the recent Royal Commission on the supply of coal, were needed to furnish the data necessary for conclusive reasoning. It now appears that the total quantity of unoxidised carbon under the British Islands, cannot be less, and is almost certainly immensely greater, than three hundred and fifty thousand million tons. This total is thus arrived at. The quantity of coal which the Commissioners estimate might actually be got from depths not exceeding four thousand feet in the areas occupied by the coal measures, is :

	Tons.
In seams not less than 1 foot thick	146,000,000,000
And at a greater depth	48,000,000,000
Allowed for waste in getting, about	80,000,000,000
Add to this :	<u>274,000,000,000</u>
The quantity in seams, less than 1 foot thick, at least $\frac{1}{4}$ th ...	45,000,000,000
Bituminous matter in the various shales, at least *	<u>40,000,000,000</u>
Making a total of	359,000,000,000

Some shales actually contain twenty-five per cent. of bitumen.

Now, this refers only to the coal fields proper, which cover only one-twentieth of the whole area, and it supposes the other nineteen-twentieths to be destitute of carbon. But this is so far from being true, that nearly every geological formation contains unoxidised carbon in greater or less degree. The estimates, also, are limited to an extreme depth of little over a mile, while the sedimentary strata are many miles in thickness. It is, therefore, quite certain that the true quantity is enormously greater than the estimate given above, which, for the entire area of Great Britain and Ireland, is equal to an average of three million tons per square mile.*

Now, there is no real reason to believe that the average is greater here than in other parts of the world. The great productiveness of our coal-fields has been due to their position and to the energy with which they have been worked, and not to any exceptional abundance in the deposits themselves. No one was aware of this a few years ago, for coal-fields are not discovered till they are looked for, and their true extent cannot be estimated without elaborate examination. But it is known now that vast quantities of coal, and of other carbonaceous matter, exist in every part of the world; and many great coal-fields have already been shown to be richer in average quantity than ours. Nor is there any doubt that such deposits exist under the sea as well as under the land, since all the known coal-fields have been below the sea bottoms of former days; and the submarine deposits, not having yet been subjected to much denudation, are likely to be even more extensive on that account.

The estimates, also, being limited to the coal-fields proper, and to so moderate a depth, exclude far more than they include. In the Laurentian rocks of America, for

* See Note B.

example, the quantity of graphite is so enormous that Professor Dawson supposes it may be equal to all the carbon in the coal formations.

Bischof, estimating the carbon in the sedimentary rocks from data of a less definite kind, has found the quantity to be astonishing, and not to be accounted for on the common theories concerning terrestrial physics, and has been led to make the singular remark that carbon cannot be regarded as existing at the time of the creation.* It is more reasonable to infer that the theories in question cannot be true, for the proofs that carbon existed long before any period known to science are sufficiently abundant.

We may again, therefore, be certain that our estimate must be less, and not greater, than the truth, if we take the average arrived at above, and suppose that the unoxidised carbon in the earth's crust is at least equal to three million tons per square mile, or a total of six hundred billion tons. But even this is six hundred times as much as the atmosphere contains at present, and, if drawn from a denser atmosphere, the proportion of carbonic acid in it must have been six hundred times as great as now.

And, in removing this carbon from the air, the action of plants would release one thousand six hundred billion tons of combined oxygen, which is nearly twice as much as the atmosphere now contains. We know that any such changes in the constitution of the air would utterly destroy every living creature, and that nothing of the kind, therefore, has really occurred during any known epoch; but we also know that this quantity of carbon has really been withdrawn from the atmosphere, and all this oxygen really set free, within a period of not more, and almost certainly much less, than about forty thousand years.†

* *Chemical Geology*, vol. ii., p. 252.

† Annual deposit = 15,000,000,000 tons \times 40,000 = 600 billion tons.

It follows necessarily that the carbon thus withdrawn has never existed all at once in the air, but has been gradually supplied to it, and that the oxygen thus released has not been left to accumulate, but has been removed as fast as it came.

How, then, has this been brought about ?

Carbonic acid can be expelled from carbonate of lime by heat or the action of other acids ; by sulphuric acid, for example, or by silica and boiling water. And the limestone rocks of the earth's crust contain it, of course, in almost unlimited quantity.

But such changes do not appear to be capable of supplying what is wanted, because the altered rocks reappear at the earth's surface, and there go through fresh changes, which enable them to reabsorb carbonic acid. And still further, because if this were the true source of the supply, it would result in a constant decrease in the carbonate of lime, and a corresponding increase in the unoxidised carbon of the crust of the earth, to an extent so prodigious in the course of geological time that it becomes incredible.

And, on the other hand, what substance is there on the earth's surface which is capable of removing the oxygen ? Some metallic oxides lose part of their oxygen in contact with organic matter, and may reabsorb it from the air ; but we know that only a small proportion of organic matter is oxidised in this way, and, as all the carbon in it must be oxidised, in order to remove all the oxygen previously set free, the process is manifestly insufficient.

Still greater would be the difficulty of understanding how two independent processes could be made to balance each other with such constant exactitude.

If the quantity of carbonic acid supplied to the air is not

determined by the quantity of oxygen withdrawn from it, it is incredible that there should be neither excess of one nor deficiency of the other through centuries and ages.

To make the whole process natural and rational, we ought to find that the carbon and oxygen which are separated by the action of vegetable life, are again united by some other agency; in other words, that the carbon annually deposited in the crust of the earth combines again with the oxygen annually given to the atmosphere. If the two substances are brought together at a sufficient temperature, they combine at once by ordinary combustion, and the question is whether this, in fact, takes place under ground.

Now, physicists have hitherto decided this question in the negative.

It is argued, with perfect truth, that if carbon is oxidised by atmospheric air, the nitrogen of the air is left unaltered, and that if this occurred within the crust of the earth, nitrogen in large quantities must be returned to the atmosphere; and, since the gases known to be discharged from the interior contain a very small proportion of nitrogen, instead of a very large one, it is assumed at once that subterranean combustion cannot take place on any large scale.

I believe this conclusion has been arrived at without sufficient consideration, and that a few facts and figures will show it to be entirely invalid. The whole matter depends on the quantity of nitrogen exhaled from the earth.

When carbon is burnt in air, the residual nitrogen is about ten times the weight of the carbon. If the annual deposit, which we take as fifteen thousand million tons, were burnt, one hundred and fifty thousand million tons of nitrogen would have to be discharged. But this, if spread over the whole earth, would make a layer of nitrogen less than one foot in thickness. If, therefore, the whole earth were

slowly exhaling nitrogen, the required quantity would be discharged, if it rose only at the rate of one foot in a year.

Now, the discharge of gases from the earth is never noticed unless they are rising, not at the rate of one foot in a year, but of many feet in a minute, which is some millions of times faster; so that, in fact, the whole quantity might be discharged from a very small fraction of the earth's surface, and still at so slow a rate that it could not be perceived.

That nitrogen is not found in quantity among the discharged gases hitherto examined is, therefore, a fact of no significance, unless it can be shown that those gases must come directly from the places where internal combustion takes place, if it occurs at all. But the reverse of this is really true.

The discharge of gases is generally observed from the craters and fumaroles of volcanoes, or from fissures in the neighbourhood of springs charged with carbonic acid gas.

In the latter case, carbonic acid is itself the gas chiefly discharged, and this is readily accounted for. The water of springs, when it reaches the surface, seldom contains much more than its own volume of this gas; but lower down, under greater pressure, it dissolves many times its own volume, and carries this with it in its subterranean course. But as the water rises the pressure diminishes, and the surplus gas makes its escape, passing upwards through any fissures open in the ground. Clearly, no nitrogen can be looked for here.

As to the gases issuing from volcanoes. Combustion itself is not likely to be at any time the immediate cause of volcanic action, which much more resembles the effect of the sudden contact of molten matter with water; and the gases discharged are such as might be expected from such a cause. Steam is the explosive agent, and carbonic acid and sulphurous gases are its natural accompaniments, because

these are driven from carbonate of lime and from sulphurets, simply by excess of heat. Carbonic acid also, being largely absorbed by water, is expelled from it by its conversion into steam. In these examinations, therefore, we have looked for nitrogen where we were not, under any circumstances, likely to find it, and no conclusion can be properly drawn from its absence with regard to combustion under ground.

Consider, further, what are likely to be the real conditions of such combustion. Carbon, like other deposits, descends ultimately to a considerable depth, and this is necessary before it can be burnt.

Apart from various reasons concerning pressure and temperature, the mere percolation of water would prevent combustion near the surface. Water may penetrate to great depths, but the rate at which it does so will evidently decrease as the depth increases; and it is the rate, and not the total quantity, that determines this point. Water thrown by teaspoonfuls, at short intervals, on a common fire, will not extinguish it in any length of time, while a moderate quantity, thrown a cupful at a time, will put it out. At a certain depth, which is probably several miles, the rate of percolation will be so slow, that a fire once kindled will not be affected by the ordinary descent of water. A mass of burning carbon in such a position will continue burning with an extremely slow supply of air, because the conduction of heat will be almost imperceptible. If air is in any way supplied, the heated nitrogen and the carbonic acid formed by combustion will slowly rise through the strata above. When water is met, the carbonic acid will, to a large extent, be absorbed by it, and will thus be carried in whatever may be the direction of the subterranean flow, while the nitrogen will pass on unabsorbed, and will make its way to the surface by whatever path is open. This natural separation of the two gases is a

sufficient reason why we should not expect them generally to reappear together.

Wherever the heat of the burning carbon is sufficiently intense, portions of the rocks will be melted by it. Once melted, they will continue long in a fluid state, from the slow rate of cooling, and will make their way downwards and laterally, through any crevices in the crust. As such crevices are channels to which water also can penetrate, they will meet occasionally with water in quantity sufficient to cause an explosion, and an earthquake, a volcanic outburst, or both combined, will be the result.

Now, we know that there is a sufficiently high temperature below, in at least a great number of places, to set carbon on fire if air is present. And there are many independent ways by which subterranean fires may be kindled when the fuel is ready, through chemical action, or mechanical friction in the crust.

We also know, from volcanoes and springs, that the earth is full of cracks and openings, which must often be filled only with air.

Every active volcano is like the up-cast shaft of a mine. Its tendency is to draw in a down-draught of air through other openings. And, besides these chimney-like fissures, the earth's crust is full of cavernous hollows, which must often be of vast extent, and in which large quantities of air must frequently be stored. Such hollow chambers are the unavoidable result of movements in the crust, of the expulsion of gases and volcanic matter, and of the solvent action of the water which escapes in springs. And that air must often enter them must be inferred from the extreme rapidity of its movement compared with that of water, and from the very minute openings through which it will pass. If a crack

opens suddenly from the surface of the ground to any depth below, it is filled almost instantaneously with air, long before water has time to ooze into it; and a little irregularity in the direction of the fissure will make the water, when it comes, act as a stopper to all the air beneath it. A column of water only a hundred yards high exerts a pressure of ten atmospheres, and air, thus compressed, will force its way wherever there is least resistance. The high specific gravity of water, compared with that of air, must often also be the frequent means by which subterranean passages are opened to the air. When these are filled with water, which is their general condition, any failure in its support, whatever that may be, causes a sudden fall in the column of water, the place of which is immediately filled with air. The air penetrates, not only directly downwards, but into whatever lateral openings there may be on the way; and, if the water rises again, the air in these openings is shut up and imprisoned by it.

This kind of up and down movement must be continually taking place in all parts of the earth's crust where the surface is exposed to the atmosphere, and must produce a species of respiration. The sudden drying of wells, so often noticed in volcanic districts, illustrates the process. It means, of course, the sudden fall of some aqueous column, and the consequent opening of a passage for the air.

There appears, therefore, no reason to doubt that air, in large quantities, penetrates the earth's crust to a considerable depth; that it may often accumulate in subterranean hollows, and that the up-draught of active volcanoes may draw it in a species of furnace blast through the fissures in various strata.

Such being the case, there seems no difficulty in believing that carbon deposited in the earth is slowly burnt within the

crust itself, for the needful temperature and the required oxygen are both supplied.

The nitrogen returns to the air by a process generally imperceptible, although the fact of its presence at great depths, and under very powerful pressure, is made known by its abundance in some natural springs.

Probably it escapes chiefly through the sea, if combustion occurs deeper down than the sea bottom ; for the passage of nitrogen through two or three miles of water would be infinitely easier than through an equal thickness of rock.

If this is admitted, the constancy, of which there is positive proof in the constitution of the air, is perfectly explained, if we suppose further, as there is every reason for doing, that a small excess of carbonic acid in the air stimulates vegetable and depresses animal life, and that the opposite effect is produced by a small deficiency.

In that case, if the amount of carbonic acid exhaled from the crust exceeds the average, there will be a more rapid growth of plants and a less rapid growth of animals, and therefore a larger withdrawal of carbon from the air, and, at the same time, a decrease in one important source of its supply. If, on the other hand, the subterranean supply falls short, the animal life is stimulated, and more carbon is oxidised by that means, while the vegetable world languishes, and less is extracted from the air to be given to the ground.

The quantity of oxygen is, at the same time, kept nearly constant by the same process, which would not be the case by any other.

This is manifestly a self-correcting adjustment, and the process may have continued for an unlimited time.

On an average, the quantity of carbon burnt below must always be equal to that deposited above, because the lowering down of the strata to a certain depth, which is its necessary

condition, keeps pace with their deposition. It will be seen that, on the theory here advanced, this fact also is accounted for.

But, if this be true, it leads to most important results concerning the internal heat of the earth, and the causes of geologic change.

We have estimated the annual deposit of unoxidised carbon on the land surface as fifteen thousand million tons, or about three cubic miles of the specific gravity of coal. On the hypothesis, an equal quantity must be annually converted into carbonic acid in the crust of the earth. The burning away of this quantity of fuel would give room for the subsidence of a thousand square miles of surface, five hundred yards downwards, every century, without reckoning the matter ejected by volcanoes, or the carbonic acid expelled from limestone by the heat.

This would allow an area equal to that of Europe to subside one hundred yards in fifty thousand years, or a yard in five hundred years. Probably this is equal in total amount to any of the observed changes in existing continents.

In practical lime-burning, the coal consumed is found to expel about its own weight of carbonic acid from the limestone; and the latter, which is not pure carbonate of lime, and which has twice the specific gravity of coal, loses about a fourth of its own weight in the process. The burning of a cubic mile of coal, therefore, is able to reduce two cubic miles of limestone to a rock twenty-five per cent. lighter, and incapable, therefore, of resisting the same pressure as before. This is a further cause of depression, and also of internal heat, for the rock thus reduced is brought into the condition of quicklime, and the entrance of water will be followed by the usual rise of temperature.

The combustion of a bed of coal under a bed of lime-

stone would therefore produce, in succession, heat, earthquake shocks, volcanic eruptions, the discharge of carbonic acid in great quantities, the subsidence of the superincumbent strata, fresh heat, from crushing and friction, and from the access of water, and, finally, the re-absorption of carbonic acid by the lime, as the fuel burnt itself out and the local temperature fell. This re-absorption would again expand the rock, and might in itself give rise to a temporary movement of elevation.

The heat which passes outwards from the interior of the earth's crust, and is lost by radiation, has been variously estimated. The highest estimates make it sufficient to melt about seven hundred and seventy cubic miles of ice every year. Burning coal will melt about one hundred times its volume of ice; and the oxidation of the three cubic miles of carbon, supposed to be deposited annually by land plants, would supply nearly half the heat thus estimated to be lost.

We have then to consider the heat produced by the gravitation of unsupported rocks, in accordance with Mr. Mallet's investigations.

He has shown that if, at the depth of even one mile, any portion of the crust ceases to rest on the solid interior by which it is normally supported, the force of gravitation exceeds the utmost pressure required to crush the hardest rocks into powder, and that, when such crushing takes place, heat is developed which is the equivalent of the mechanical action.

He has also shown that the actual quantity of heat thus developed may be prodigious, if the interior support is from any cause temporarily removed, as it must be whenever a layer of carbon is converted into carbonic acid gas by oxidation.

Adding together, then, the heat produced by the oxidation of the three cubic miles of carbon derived from the land surface; the further quantity that may be due to carbon deposited by marine vegetation, and animal decay; the additional increment from the access of water to burnt limestone; and, finally, the effects of crushing and friction from the gravitation of rocks whose interior supports are burnt away; it appears that the annual loss by radiation must be sufficiently compensated in this manner, even at its highest estimate, which is, moreover, very likely to exceed the truth, while we know that our estimate of the carbon itself must be far below it.

It seems unnecessary to take account of the carbon artificially burnt by mankind. The annual consumption of coal throughout the world may perhaps be as much as three hundred million tons, but this is only two per cent. of the estimated annual deposit from land vegetation.

And it is associated with social conditions involving a higher culture of the soil, an increased production, and therefore a greater annual demand upon the carbon of the atmosphere, and a greater annual deposit from the same source.

And the industry which consumes the coal greatly increases the quantity of carbon artificially deposited in houses, furniture, ships, railways, and other human works; all the wood thus used by man being so much vegetable matter preserved from or retarded in the course of natural decay.

I have treated coal and carbon as if they were synonymous terms, in order to avoid complicated details, and because the difference between them does not affect the general result. When a ton of carbon is converted into coal, the bulk and weight of the fuel are increased, but the heat of its combustion is not greatly altered.

The theory here advanced rests, you will perceive, solely on ascertained facts, and does not require the assumption of causes which we do not really know to be operating. It is a matter of fact that carbon is annually deposited in the ground; carbonic acid is constantly exhaled from the interior of the earth's crust; air does penetrate wherever there are openings, and intense heat does exist below in great numbers of places; and the carbonic acid extracted from the air by plants is in some way returned to it, while the oxygen released is in some way withdrawn from it, without material change in the atmospheric proportion.

The inference as to the actual process is an irresistible one.

All we have had to establish is that its effects are on a scale sufficiently large to explain the facts of observation; and this being placed, as I conceive, beyond reasonable doubt, it follows that geological change, as known to us, is fundamentally dependent, not on physical, but on vital operations, and that the earth is not a cooling body.

And if it should be urged that vital operations owe their energy to the heat of the sun, and that the sun, at all events, must be cooling, the reply is easy.

We do not know the history of the sun's heat, or the source on which it depends, and it is not satisfactorily explained by any existing theory. The proof already given of constancy in the general surface temperature of the earth is equally a proof of similar constancy in the heat of the sun, which, considering the enormous length of the period, is inconsistent with the belief that he is either a simply cooling body, or that his heat is supplied by gradual condensation. The fall of meteoric matter is no longer accepted as an explanation, and simple chemical action is demonstrably insufficient by itself. Doubtless the latter cause might be sufficient, if aided by vital operations, but then, in the sun's

case, we know of no external source from which these could derive their energy, unless they can draw it from the ether of space, and of this there is no evidence.

The violent action manifested in the solar atmosphere is further opposed to the view that the sun is merely a heated body, cooling. In such a body, with no alternations of day and night, and no other globes near him of sufficient size to produce appreciable effects by their attraction, the loss of heat must be uniform, and the change of surface temperature extremely slow; and if violent perturbations and convulsive movements would, in fact, occur, we are at least ignorant of their natural causes.

The true scientific course in such a case is to confess our ignorance, and to acknowledge to ourselves that there are probably sources of heat in nature of which at present we know nothing.

In calculations of this kind the estimates of quantity are necessarily rough ones, and I have, on that account, used round numbers throughout this Paper, an attempt at exactness in such cases being only deceptive. I have taken the greatest care to employ figures that are less than the probable truth; and it is most remarkable that the results of such calculations, from data which are entirely independent of each other, should prove so distinctly comparable.

The earth's annual loss of heat is deduced from observations of the internal temperature and rate of conduction; while it is from the quantity of carbonic acid consumed by plants that I have estimated the heat which the re-oxidation of the carbon must supply.

The length to which this part of the inquiry has been carried is justified by its importance.

As I have before pointed out, the successive appearance in time of the higher forms of life after the lower forms, is a

fundamental necessity in the system of which Haeckel is the exponent, and the gradual changes to which a cooling world has been subjected are so far indispensable to the theory, that without them there is no presumptive evidence in its favour derived from the general order of terrestrial affairs. If the views laid before you are sound, our first acquaintance with the earth's history begins at a period when its surface arrangements were not distinguishable from those of the present time; when the gases of the atmosphere were supplied and removed by the process which still continues; when the rocks were deposited by the help of organic life in the sea, through agencies which necessarily imply its equal abundance on the land.

What reason, then, have we for believing that this abundant life was only of the lowest kind?

The negative evidence is worthless; the positive evidence is all on the other side.

We have no good reason to believe that life, existing at all in a world of this kind, could maintain itself without a general completeness, or that any of its main divisions could be dispensed with by the rest. Plant-eating insects multiply in such a manner that they would generally destroy vegetation if they were not preyed upon themselves. Their enemies are, again, kept down by larger animals, and these are limited in number by the comparative slowness of their own growth, which effectually prevents them from extirpating their food, while, at the same time, they check its undue multiplication. This is a perfect and harmonious system, the working of which we see before our eyes. It is sufficiently elastic to meet the varying changes of geographical and other conditions, but the balance of life is preserved by its silent operation in every corner of the world. What would follow if any part of it were entirely absent we do not know by experience, but we may be very sure that profound

disturbance of some kind or other must be the result, and every proof of close similarity between the present and the past is evidence, therefore, that the general system has been maintained.

The actual discoveries of palæontology are absolutely confirmatory of this view. The invertebrate animals of the present seas are not exactly like those of the earlier epochs, but they are so nearly like them that no one can doubt that the sponges, crinoids, shell-fish, or crustaceans of to-day, are each of them the lineal descendants of sponges, crinoids, shell-fish and crustaceans living in those forms in the palæozoic era. We are equally sure that the fishes of to-day are descended from fishes of that period; that our reptiles had reptilian ancestors, at least as far back as the trias; and that of the higher mammalia, every existing individual is so nearly like some fossil in the tertiary rocks, that we are certain it cannot differ from its ancestors of that epoch in general structure, general habits, or the nature of its food.

If we go further back, and ask, What were the predecessors of silurian sponges, or of triassic reptiles? the natural inference is that they were still sponges and reptiles, filling the same places in the general order of life.

We know that those places have been so filled, and that general order so preserved unchanged, through the incalculable periods which divide the present era, in one case, from the silurian, in the other, from the triassic age, and no reason can be given why it should have been otherwise in ages preceding these.

The evidence necessary to prove the contrary must be of the following kind. There is a difference between the recent forms and the ancient ones. If it can be shown that this difference is the natural result of a constant law of change,

and if, by following the action of this law backwards through a still longer period, we are carried through a natural pedigree to forms which are neither sponges nor reptiles, it is sound reasoning to infer that these were the forms of life from which sponges and reptiles have descended. This is precisely what the doctrine of Evolution pre-supposes, but the proof is always wanting when we look at the facts.

The difference between these living individuals and the most ancient known forms does not give evidence of any constant law of change, from which we must infer that those ancient forms themselves were descendants of organisms essentially unlike themselves. We cannot show that the new forms are the old ones altered by a constant progress or a constant retrogression, or a definite departure from one mode of life in the direction of another mode of life.

The same view is strikingly confirmed by facts concerning the higher animals. Mammalian remains are abundant in the tertiary rocks, but they vanish suddenly when we pass the boundary of this period. The change is not a gradual one. It is from an abundant record to an absolute blank.

What are we to suppose to have been the ancestors of the tertiary mammalia? Were they creatures of the same kind, differing in minor points, but alike in essential ones? or were they creatures of another kind, descendants of the reptilian forms of a former era?

The happy accident by which a few mammalian bones were found in triassic rocks ought to have settled this question. It proved in a moment that the mammalian form, instead of being a new form at the beginning of the tertiary period, had already existed for incalculable ages when that period began. Nor has the fact that the bones hitherto discovered belong to small animals of the marsupial form the least significance in sound reasoning, for marsupials are

among the living forms of the present day, and to know that they descend through an unbroken pedigree from ancestors who were essentially like themselves in the age of the trias, is to leave no reasonable doubt that the same thing is true concerning other mammals. Nor would the strength of this inference be lessened if we should continue to find only marsupial mammals in triassic rocks, for we know that the preservation and discovery of the fossils of land animals of any kind in deposits of that epoch can only be due to some special circumstances relating to those rocks; and if these have, in fact, caused marsupials only to be preserved in one particular case, the same causes are likely to have had the same effect in others.

And having traced back these highest forms of life to that prodigious distance in the past, no facts can be appealed to which render their existence less probable in Laurentian days. With a world in all respects fitted to sustain them; with our knowledge of the mutual dependence of the animal and vegetable kingdoms, and of the enormous length of time during which all forms of life have existed together without essential change in any, only one conclusion seems possible, so far as external evidence is concerned.

But if we admit this conclusion, and believe, as I think we are bound to do, that at the earliest period of which the rocks give us any record all the chief forms of life existed in the world, the general law of change in organic life is at once shown to be, not that of development from one simple form to many complex ones, but that of persistence in essential differences, with constant variation only in their associated details.

This law is in complete harmony with our experience, as far as it goes, and with every geological discovery of a positive kind. It is, of course, absolutely subversive of Haeckel's entire system, which rests upon the opposite belief; a belief

which, as far as observation concerning the past sustains it, is built up solely upon negative evidence. The worthlessness of this for this purpose is, I think, demonstrated by the facts I have brought before you, as it is undoubtedly suspected to be by Professor Huxley himself, and others among our ablest physicists, who hold fast, nevertheless, to their favourite doctrine, believing, apparently, that it can be upheld even when its original basis is cut away.

I could not, in the present Paper, attempt to examine more than one portion of Haeckel's system, and I have chosen that part which is really fundamental to the rest.

The inferences concerning blood relationship which ought to be drawn from embryology, and other lines of physiological research, are of the highest importance, but they could only be dealt with in a separate Paper.

I must, in conclusion, guard myself against any misunderstanding of the views I wish to support. To say that all the chief forms of life existed at the earliest period known to us, is neither to say that they existed from all eternity, nor to account for their actual presence in the world. It is to assert only that the evolutionist explanation of their origin fails, and must be discarded, and that Science has not yet found out how they came to be here.

How, being here, they vary in detail continually; how they adapt themselves to change of circumstance; how each in its turn has periods of rapid progress, in which the utmost capabilities of particular families are developed through many generations, and periods of retrogression, in which they degenerate, and perhaps die out; how natural selection, silently acting through all these changes, keeps the world peopled by its most vigorous inhabitants, and so insures the long perpetuation of the existing system; all this, science has discovered, or is discovering, and it is no part of my

object to detract from the splendour or depreciate the interest of these grand achievements.

It is the attempt to dogmatise where nothing is known, and to assume as established truth a doctrine concerning the origin of life which has no foundation in experience, that has to be resisted, alike in the interest of true science and of the hopes of mankind.

NOTE A.

One of the physical objections to any form of the nebular hypothesis may be stated thus:—It follows, from the laws of diffusion and fluid pressure, that, in a nebula composed of mixed gases, with or without solid matter floating in them, the several elements will distribute themselves, at any temperature, in accordance with their densities; so that the outer layer of matter in a spheroidal mass will be specifically lighter than the interior. This is recognised when the comparative lightness of Jupiter and Saturn is pointed at as confirming the theory. But the earth, on the hypothesis, was formed from the equatorial portion of the outer layer, when the diameter of the solar nebula was that of the earth's orbit. It consists, nevertheless, of heavy and light materials mixed together in vast proportions. The exterior planet, Mars, and the two interior ones, Venus and Mercury, are all, moreover, nearly of the same density as the earth, while the density of the sun is only one-fourth of this. The sun's comparative lightness may be partly explained by his high temperature, and partly by errors in estimating the size of his nucleus; but there is no indication of the existence in the sun of denser elements than those we are acquainted with, or of a higher average in the proportion of heavy matter. The densities of Jupiter and Saturn are extremely

doubtful, since we do not know the depth of their atmospheres; and the facts concerning the other planets appear irreconcilable with a nebular theory, either hot or cold.

NOTE B.

EARTH'S ATMOSPHERE.

Total weight	- - - -	5,000 billion tons.
Of which—Nitrogen	= 4,000 billion tons.	
Oxygen	= 1,000 " "	
Carbon	= 1 " "	= 3 $\frac{2}{3}$ billion tons [carbonic acid.]

ANNUAL VEGETABLE PRODUCTION.

		Per square mile.
Land surface	= 50,000,000 square miles.	
Average annual growth, dry vegetable matter, left after animals feeding on growing plants have been fed; estimate, includ- ing roots, = 8 tons per acre	- - -	2,000 tons.
Of this—Carbon = one-half	- - -	1,000 "
Left unconsumed by animals feeding on mature vegetation; estimate, one-half	- - -	500 "
		[carbon falling [annually on [the ground.]
Of this, two-thirds remains unoxidised	- =	300 tons.
Total annual deposit of unoxidised carbon on land surface =	- - -	15,000,000,000 tons.
Water surface	= 150,000,000 square miles.	
Average annual growth, dry vegetable matter =	}	Not included.
" " deposit		

VEGETABLE CARBON IN EARTH'S CRUST.

Per square mile of total
area British Islands

Average for British Islands, from estimate of coal-fields only, to a depth only of a mile and a half, nineteen-twentieths of the area being assumed to be destitute of carbon - - - - - 3,000,000 tons.

Earth's area = 200,000,000 square miles.

Total fuel in earth's crust, first mile and a half, at same average, = 600 billion tons.

On estimate of annual deposit given above, this quantity (600 billion tons) would be deposited in 40,000 years.

The above are all given in round numbers.

DISCUSSION ON MR. MOTT'S PAPER.

The reading of **MR. MOTT'S** Paper occupied the whole of the evening, and it was resolved to devote an evening to its discussion. This discussion took place on the 22nd of January, and the following are the remarks of the chief speakers.

DR. DRYSDALE.—I join heartily in the commendation which this Paper will no doubt receive on all sides, and which it deserves. The author merits the gratitude of all members for bringing before us such a resumé and original critique of one of the most important questions of the day. Apart from that, it contains also an original treatise and argument on the continuity of terrestrial, chemical, and vital processes, which is too important to remain as part of a mere critique, and which I hope will be expanded and published separately. As to the whole scope of the Paper, the best sign of appreciation is, I think, not mere panygeric, but criticism as rigid as possible. First, then, the attitude of the author towards Haeckel's unflinching pursuit of scientific reasoning to its logical conclusion. This he praises. Then immediately blames, because Haeckel excludes purpose and plan, and sees nothing but matter and force, governed by unchanging laws. Here I join issue with the author, and assert that science proper is in its right place, and has no concern with plan or purpose. If it leaves a large gap, or positively conflicts with hopes and ideas we derive from other sources than science, it is for philosophy, or something higher, to reconcile the two. On this point one would like further explanation from the author to justify the prejudice raised against Haeckel's theory by pushing forward its

atheistic tendency, while, at the same time, he rejects the common modes of reconciling science and religion by the mere mode of stating them, as done at page 43, viz. :—"Some, indeed, are satisfied by a simple trust in supernatural power, as able, under any circumstances, to fulfil the promise upon which Christians have so long relied ; but the keener sighted perceive that all the evidence of that promise, and all the reason for that trust, are really swept away by a theory which makes mind itself the mere passing product of the clash of atoms. Some endeavour to escape the difficulty by appealing to the indefinite possibilities lying hidden in the vast region of the unknown ; some take refuge in the idea that, while the ancestors of mankind were perishable beasts, a living soul was given to the race when a fitting bodily form had been developed."

I, for one, am happy to say that I am not keen-sighted enough to perceive why the evidence of this promise is swept away if life and mind are the passing product of the *clash of atoms*, if that is a proper expression for the interactions of this transcendently complicated and wonderful combination known as living matter. When we see life and mind displayed more or less fully by the whole animal creation, from the elephant to the worm, only just exactly so long as this material organism is perfect, and no longer, what right have we to suppose that these faculties depend on an immaterial substance added to matter when organisation begins, and withdrawn again, or even actually perishing, when this material organisation is dissolved at what we call death ? True science acknowledges no such right, nor can it pretend to show the existence of any immaterial substance. It deals with matter and force alone. And if in "the indefinite possibilities lying hid in the vast region of the unknown," I am assured, on sufficient authority, that the Almighty had granted immortal life and mind to man, whose

body was developed from an ancestral race of perishable beasts, I have no difficulty in accepting the belief as consistent with the Darwinian theory, just as much as with that of direct creation of man. Haeckel's positive Atheism, or Pantheism, is wholly unwarranted as a deduction from science, even if his complete theory of evolution is right, which I by no means grant. Science, certainly, may fail to give proof of the existence of design, or show us the nature of God, but cannot disprove His existence. I was, therefore, very curious to hear what one who rejects the appeal to revelation, and even the indefinite possibilities of the unknown, would say; but, to my surprise and disappointment, I have heard nothing of the author's scheme of the universe. And, in fact, nothing but an elaborate argument to show that, as far as scientific evidence goes, "all things continue as they were in the beginning," if, indeed, there was any beginning. He guards himself by saying that he does not assert the eternity of living and other things as they are; nor explain how they came to be, if they came to be; but at the same time asserts there is no evidence that the sun, and the planets, and the earth, and all upon it, vegetables and animals, not excepting man, were ever different substantially from what they are now, or were ever non-existing, or shall ever cease to exist substantially as now. This, I think, is a theory quite as compatible with negative Atheism as Haeckel's is avowedly with positive, or Pantheism. Therefore, if the author refuses to qualify it by the more common methods, he should have told us his own method of defending it from the imputation. Haeckel's Pantheism is not a deduction from the evolution theory, nor from natural science at all; it is nothing but Spinoza's Pantheism, which was reached by purely metaphysical reasoning; and Haeckel's book is merely an attempt to show how the evolution of life may be explained consistently with it. As a matter of fact, I consider Haeckel

has entirely failed to fill up the immense gap between inorganic and the very simplest organised matter; so, practically, he has not disproved the received belief, that at some point miraculous intervention must have taken place to account for the origin of life. And as to their general tendency, his opinions and those which hold that all things may have gone on for ever as they are now, are very much on a par. So much for the general scope of the evolution theory, which is the chief part of the paper. To turn to a few details. The author admits that the old ideas of the fixity of species were entirely mistaken, and that, in a general way, the Darwinian theory is "no longer a matter of debate." But the question is, how far can one form of life change into any other, or is there any definite law as to degree or direction? This is, I apprehend, nothing more than Darwin's question which he left unanswered. Is there only one stem, or phylum, to which all species may be traced, or were there several such stems, which came into being simultaneously, or successively? The same question is further discussed by Haeckel, under the head of the monophyletic and polyphyletic origin of living beings. That is, from a single stem or phylum, or from many such. Now, we must remember that Haeckel's hypothesis supposes the formation of several or many different kinds of living matter, by primordial generation from non-living matter. Hence many stems may have no blood relationship, and thus there is a natural limit to the evolution of particular species. And also, that this question of origin from one or several stems is continually turning up in the natural history of each species. The tendency of the evolution theory is certainly to reduce the stems to as few as possible. For the present, Haeckel thinks we must at least admit a separate stem for plants and animals. But, intermediate, there exists a whole kingdom of Protista, consisting of eight classes.

And below them all a lowest living deep, called Monera. I will now read Haeckel's own words:—"If we adopt the polyphyletic descendance-hypothesis, we must assume a greater or lesser number of stems or phyla, which have all originated independently by primordial generation. In that case there must have arisen numerous different kinds of Monera, whose difference must have consisted in slight chemical alterations, to us not recognisable, but on which depended their capacity for development. A small number would have been the source of the vegetable, and another small number, of the animal kingdom. While between these would still remain a portion, and develop as a kingdom, neither animal nor vegetable, *i.e.*, the Protista." He gives here a diagram showing such an origin of the three kingdoms from Monera, while a vast number of different kinds of Monera perish. Although he is inclined to the mono-phyletic theory, or the final reduction to one stem, he says the present state of knowledge does not allow the question to be decided. So we see, after all, the difference between Mr. Mott and Darwin, and even Haeckel, is only one of detail and degree. According to the first, we have no reason to suppose otherwise than that the same kind of creatures, somewhat modified, but still recognisable, ancestors of the present fishes, birds, beasts, and even men, existed in the Laurentian period, or, in fact, at the very beginning, if there was a beginning; while the last two believe the evolution of species goes back to a far more rudimentary form of life. Of these two hypotheses, I am inclined to prefer that of Darwin and Haeckel, and if this geological evidence is negative in the one case, it is most assuredly equally so in the other. As the time is about exhausted, I shall only touch briefly on one or two points more. First, I cannot but feel surprised the author dismisses so briefly, as a mere speculation, the universally received belief of the former fluidity of the earth resting on its shape as an oblate

spheroid. He does not give a word of explanation as to how it could get that shape, except by revolving as a non-rigid body. At the same time, I believe it is now admitted by men of science that the crust of the earth has been rigid, and ceased to lose heat for a time quite as long as the Laurentian period. Likewise, it is not needful for evolution hypotheses that the surface should have had a higher heat derived from internal sources than now. Nor that there should be any excess of carbonic acid in the atmosphere. Now, Mr. Mott's original part, showing that combustion of carbon must be continually going on as one element in the balance of carbon and oxygen, is very striking, and will, no doubt, attract the attention it deserves from the scientific world.

But here we only need to notice the argument, that from the essential and complementary part taken by both animals and plants in maintaining the balance of oxygen and carbonic acid, there never could have been a time when the number and variety of the species of animals and plants could have differed materially from what now exist. It is assumed that, because perfect plants consume carbonic acid and evolve oxygen, and perfect animals do the reverse, there can have been no lower kinds of living beings which could exist and thrive without such mutual inter-dependence. But this is not the case, and we have a considerable number of species of protophyta and protozoa which can live and thrive on purely inorganic materials, viz., ammoniacal and mineral salts. Such we know now, and we can easily imagine them to have existed in a state of the world very different from what obtains now, and thus furnish a store of nutriment, alter the proportion of the gases in the atmosphere, and otherwise prepare the way for more highly developed forms of life.

The Rev. H. H. HIGGINS, M.A.—The most solid tribute I can pay to the merit of my friend's Paper is the admission that my attempt to answer it gives me quite enough to do, and leaves me neither time nor space for well-deserved encomium.

1. My first notice must be in the form of an unqualified protest against a statement on page 42, line 21: "In this Haeckel's argument is generally unanswerable. He shows that there is no such intermediate stopping-place as timid evolutionists are anxious to find."

I am a timid evolutionist. I shrink from the thought of that personal annihilation imposed by evolution unlimited or unconditioned. I burn to know more of nature than these eyes can see; more of that world of enchantment, music, than these ears can hear; more of loved friends, whom I can only half know now; and the thought that all this is impossible, could it be entertained, would go far to unman me. But evolution unconditioned exists only in the imagination of idolatrous theorists—*nature knows nothing of it*; and as for a stopping-place, I do not know a single main line in evolution which does not very soon lead you where stop you must. For life has not yet been known to be evolved from lifeless matter, nor living growth from protoplasm and environments, nor human intellect from the instincts of brute animals. These breaks, at which hitherto the most adventurous theorists have been compelled to halt, or to leave "the solid ground of Nature," may well serve as stopping places for timid evolutionists.

2. Intermediate forms. The argument on pages 48-54 deals with a very important question concerning the testimony of intermediate forms. The method is briefly this.

A, B and C are three living forms, of which B is intermediate between A and C. B may, of course, stand for any number of intermediate forms, differing by small gradations. The paper contends that the existence of B does not show that A and C had a common origin, since B may have had a distinct pedigree of its own as long as that of either A or C.

This is logically unanswerable. Biologically, much may be said in reply. For the intermediateness of B, a living form, or a group of forms, may biologically have much significance or no significance at all. The deficiency in my friend's argument is owing to his having treated the question in a manner too logical and too precise. For biology is not an exact science; I might say, quite the reverse; as are also all sciences involving life and the way in which life behaves.

3. On page 48, line 23, a complaint is made that science gives no satisfactory answer to the question, "Is the tendency to vary a limited or an unlimited one?" If I take upon myself to answer in behalf of science, "The tendency to vary is limited," my friend has, I think, no resource except the further question, "Where is the limit to be drawn?" to which I may reply, "I don't know;" which, I submit, is a thoroughly scientific answer, though not, perhaps, a satisfactory one.

4. On page 52, line 28, it is stated that no individual would be exactly like his distant progenitor. This seems to be a simple statement of an unquestionable fact; but I may, nevertheless, use it as an illustration of the wide difference between practical biology and logic.

The individual in question would have two parents, four grand-parents, eight great-grand-parents, sixteen great-great-grand-parents, and at the tenth degree back no less than one thousand and twenty-four progenitors, all different. The

individual could hardly be exactly like each of these ; but—and this is the point I wish to enforce—it is quite probable that the individual might, biologically, be easily, and without any doubt, identified with each of the thousand and twenty-four progenitors, if they could all be found.

Logical and biological sameness are by no means equivalent terms.

5. Unoxidised carbon. The deeply interesting argument, occupying pp. 64–81, appears mainly to rest on a statement made by no less an authority than Bischof, p. 65, line 25 : “Of vegetable matter falling on the ground, a great part of the carbon remains there.” “On an average it may be assumed that two-thirds of the carbon falling on the ground remains there as a permanent deposit.” My reasons for thinking otherwise I will now state. My friend considers that the carbon thus deposited sinks slowly into the ground, and is there oxidised. “Carbon,” he remarks, p. 73, “like other deposits, descends ultimately to a considerable depth, and this is necessary before it can be burnt.”

I believe that it does not descend at all. Its specific gravity is less than that of earthy materials ; and if you shake up shot and mustard-seed, you will never get the mustard-seed to go to the bottom. Carbon is almost insoluble, and cannot be carried down in a state of solution. Air, though very light, descends into the earth because it follows the laws of expansion of gaseous bodies ; but carbon must behave in accordance with the laws of the specific gravity of solids.

It is true that vast accumulations of unoxidised carbon have been deposited in former ages, but our woods and forests are not producing coal now. No, if you would witness the nearest approach, in our days, to the formation

of a bed of coal, you must go, not to the luxuriant vegetation of a tropical forest, but to the humble turf-bog, where cæspitose plants, chiefly Sphagnum, the Bog-Moss, are depositing unoxidised carbon in the form of peat. How is it that the frail Sphagnum of the bog can deposit its remains for after-centuries, whilst the giant timber tree of the forest falls and is soon clean gone? It is because the mode of growth in the Bog-Moss enables it to seal, cover up, and protect its dying and dead stems and leaves, excluding those living germs, visible or all but invisible, which are the mighty agents in all animal or vegetable oxidisation.

That this is the true explanation appears also from circumstances which occur almost everywhere. Examine a pond overhung by trees, the leaves of which fall every year into the pond. At the bottom you will find black carbonaceous mud, often many feet in depth, the gathering of many years. The water has excluded the living germs. The carbon is all there at the bottom of the pond; it has not sunk into the earth.

Again, the presence of Protophyte Fungi, Bacteria, and the like, in dead vegetable matter, is not merely conjectured. Who does not know that an infusion of hay swarms with them? What is their natural course of life? Not to be put under a microscope—nothing of the kind. Let the farmer give them a chance, by permitting his hay to become damp, and they, together with various forms of *Mucor*, will soon show their activity.

This process of slow combustion has received the name of Eremocausis; fatty acids and dry cellulose being able longest to resist it.

As I walked in the untouched forest of Dominica, last year, I said to myself, There is no accumulation of vegetable matter here. And Why? Not because the carbon had sunk into the earth, but because there was not a leaf or a

splinter on the ground which, when examined with a powerful lens, did not show the oxidising activity of vegetable parasites, sometimes two or three deep; the blackened scar of a Pyrenomycetous Fungus, yielding in its turn to further decomposition wrought by a fungus that I could not distinctly see. Soon all that would be left of the mass of decaying vegetation in the deep forest would resemble the red clay at the bottom of the deep Atlantic, for there only would remain the incombustible ashes of the Protophyte Fungi, which had burnt up everything else. Under circumstances admitting air and moisture, instead of an annual deposit of unoxidised carbon, according to Bischof amounting to 15,000,000,000 tons, it seems probable that there would be no deposit, or a trifling one.

But how about the coal beds? Perhaps there were no Protophyte Fungi then. Far more likely it is that the coal vegetation was protected as peat is protected now by its producer the Bog-Moss. Showers of Macrospores, masses of Lepidodendroid integument; these formed the coal.

My friend thinks there has been no great change in the types of living things since the earliest period of which we know anything. Vegetation has probably changed in type since the carboniferous era. The giant plants of those days were more in affinity with the Club-Mosses and Bog-Mosses, than with the Angiosperms of the present age, and these include all our forest trees except the Fir tribe, and also by far the greatest part of the vegetation now in existence.

W. Carruthers, F.R.S., states, that in the Calciferous Sandstone, at the very base of the Carboniferous strata, occurs a true angiospermatous plant. It has also been asserted, on good authority, that a marsupial mammal occurs in the Trias. What the disciples of Haeckel have to say in this matter, I know not. Theirs is a theory which admits of no exception. A single genuine exception is as fatal to

the claim of infallibility as ten thousand. A Trias Mammal, or an all but Silurian Angiosperm, altogether dislocates Haeckel's genealogical tables; throwing back the whole of the pre-mammalian, or the pre-angiospermatous divisions, into the extreme depths of the past, and leaving little or nothing for evolution to accomplish since a period inconceivably remote.

This is not the occasion for arguments in support of a theory of development. I should be quite satisfied to have conceded a general progress, however slow or gradual. Perhaps my friend, at some less brave times, is disposed to admit that his cycles may not be perfect rings or circles, but rather, we will say, spirals. The earth is said annually to return to the *same place* in its orbit; but when the time comes round, earth, moon, sun, and orbit, are all millions of miles away on their progress. Yet, to an ordinary observer, our place looks wonderfully like where we were a year ago.

Mr. A. E. FLETCHER.—If we may take it as a fact that some of the coal or other carbonaceous masses are destined to subterraneous combustion after being buried at great depths, the thought is suggested that this generation of heat deep in the earth's crust is in accord with that other beautiful contrivance by which the sun's heat is carried down through the depths of an otherwise frozen ocean.

As is well known, water and other liquids become heavier, bulk for bulk, as they cool, so that the colder portion of a liquid is found at the bottom, and the hotter portion at the top of the mass, with a notable exception that in the case of water a maximum density is reached at the temperature of 40° Faht. The effect of this is, that if the sun shines

upon the surface of water at a temperature below 40° , the upper portion will, on being warmed, become heavier than that below, and will therefore sink, thus carrying with it the warmth received from the sun's rays, down even to the bottom of the ocean.

We may, perhaps, therefore, associate the two phenomena, as designed to carry out the same object, namely, that of conveying the heat of the sun's rays down deep into the crust of the earth, to a position it would not reach by conduction only. For the heat given out by the combustion of coal is but the heat which has been received from the sun, when under the influence of its rays the woody fibre and other vegetable structures were formed, which in time became consolidated and conserved as coal.

It must be conceded also that did a subterranean combustion take place by means of the agencies indicated by our essayist, the heat accumulated might reach a degree of intensity which we cannot easily imitate in our furnaces, for there the heat is dissipated through the walls. Here, however, imprisoned within walls of unlimited thickness, the heat would accumulate till it reached an intensity we cannot equal in the appliances at our command.

Dr. WM. CARTER read the following extract from an article written by himself in the *Quarterly Journal of Science*, in April, 1865, showing that he concurred in Mr. Mott's position, that there was no evidence against an extensive animal and vegetable series in very ancient times.

“ And yet, after having descended into the regions of an immeasurable antiquity, Geology is obliged to confess her inability to reach the beginnings of life on the earth, admitting that, for aught she can tell, as extensive an animal and

vegetable series might have existed previous to, as since, those earliest traces which she has yet discovered. For every new revelation serves but to strengthen the probability that the entire series of rocks is passing through a ceaseless cycle of change, and that granite itself may be but the extreme term of a metamorphism that, by its intensity, has obliterated all vestiges of organisms with which it might once have abounded. Certain it is that the Histiodermas and Oldhamias of the Cambrian period have lately been proved to be recent, compared with the incalculably more remote Polyzoa and Foraminifera brought to light in the lower rocks of the Laurentian series, which, in their turn, will probably be shown to be as far removed from organisms of an earlier period yet to be discovered."

MR. GEORGE H. MORTON, F.G.S., said that he differed in opinion from Mr. Mott with regard to many of the statements brought forward in his Paper, but that he would confine the few remarks he had to make to three of them. At page 44, Mr. Mott speaks of "continually putting back the date at which the earliest examples of each particular form are severally found," evidently referring to the first appearances of the classes of the vegetable and animal kingdoms in the geological formations. Mr. Morton called attention to a Paper of his own, in the *Proceedings* of the Society for 1858, in which a table is given showing the earliest records of each class in the successive formations; and stated that there does not seem to be any material difference between it and similar tables, more recently published, after the accumulated observations over a large portion of the earth's surface during the interval; indeed, it is remarkable that so long a period in the history of the science should

have produced so little alteration. So far as the Reptilia are concerned, the lowest are now referred to the Carboniferous, whereas, in 1858, the *Telerpeton Elginense* was supposed to occur in the Devonian, in strata since proved to be Triassic. Mr. Morton referred particularly to the absence of the remains of fishes in the Silurian—except in the very highest beds of that system—and expressed his belief that if they had existed during the early ages of that period, some of their remains would surely have been discovered.

Mr. Mott says (at page 45), that Haeckel shows that “in the seventy thousand feet in thickness of the Laurentian, Cambrian, and Silurian systems, a thickness which, in his belief, required many thousands of millions of years for its deposition, by far the largest portion is in that metamorphic state in which no fossil forms can be recognised.” Mr. Morton admitted the correctness of the statement, so far as the Laurentian was concerned, but not with regard to the Cambrian and Silurian systems. He said, “that neither of these are metamorphosed in the typical districts of North Wales, nor in many large tracts of country in other parts of the world. There certainly are regions where such rocks are metamorphosed, but that might be said of more recent formations. The few traces of low organisms that have been observed in the mass of the Cambrian strata* go far to prove the paucity of life and the absence of the higher classes during that period, while the splendid collections of Silurian fossils that have been obtained in England, Europe, and North America cannot be disposed of as “the few remains which have been found here and there as the sole organic records of this vast period.” (Page 45.)

Lastly, Mr. Mott (at page 58) states, “The largest sedimentary deposits in the known crust of the earth owe their origin, not to mechanical, but to vital operations,” which is

* Cambrian of the Geological Survey.

the reverse of the actual fact, and it may easily be shown that the mechanically-formed rocks are by far the largest portion of the earth's crust. The Laurentian is about thirty thousand feet thick, and contains about three thousand feet of limestone, so that only one-tenth has been formed by vital agency. In the Longmynd rocks, east of Church Stretton, the Cambrian is about twenty-six thousand feet in thickness, with about ten feet of limestone near the base, only two thousand six-hundredth of the whole. The Silurian of the West of England, along the border of Wales, is about twenty-two thousand feet thick, and the united thickness of the Llandeilo, Woolhope, Wenlock, and Aymestry limestones altogether is only about three hundred feet thick; while in the Silurian of North Wales there are only the Bala Hirnant limestones, about thirty-five feet thick, so that the limestone, compared to the mechanically-formed rocks, is very insignificant. The carboniferous limestone, with an average thickness of one thousand feet, is a very important organically-formed formation; but when from six thousand to ten thousand feet of coal measures are added, the proportion of vitally-formed strata, including the coal seams, cannot exceed one-sixth of the whole carboniferous system.

Mr. T. WARD.—We have had the Paper discussed by scientific men from their various stand-points. I wish to make a few remarks as a non-scientific man.

The point which seems to me to be one of the most important in Mr. Mott's Paper is the following, on page 47:—
“Animal life was as abundant and as varied in the earliest period known to us as it is at the present day; all its typical forms existed then.” To substantiate this, Mr. Mott brings forward a very ingenious and elaborate hypothesis respecting

the quantity of carbon existing in the air and the necessary interdependence of plants and animals. Mr. Mott says things must have been in past ages what he has described, and whether there is any evidence of this or not is immaterial; if facts seem to negative the conclusion, so much the worse for the facts, for the theory says such facts could not be. Now, I have always understood that geological facts show a distinct line of progressively developing forms. In all geological works with which I am acquainted this seems to be the case. There is no appearance of irregularity; we do not find in the earlier formations a larger number of highly developed forms than in a succeeding formation; then a preponderance of the lowly developed forms and an absence of the most highly developed; and again, the highly developed, and then again the very lowest forms; and so on in an uncertain and irregular order. What evidence there is points to progression from the lowly developed to the more highly developed forms. Now, on the doctrine of probabilities, is it at all likely that throughout myriads of ages, in which, according to the hypothesis, animal life, in all its typical forms, existed as plentifully as now, that the only specimens of this form of life preserved to us should show a distinct line of progression from lower to higher forms as the ages progressed? Such a species of selection would be infinitely more wonderful than Darwin's. Would it not be more logical to say, We find certain traces of life at certain periods. It is true that these represent only a small proportion of the living beings in existence at those periods; but, at all events, this proportion will fairly represent the existing beings of the time. If, then, there be absolutely no traces of certain forms of life in any of the deposits of the period, it is reasonable to conclude that such forms were not then in existence. We must draw our conclusions from the facts which are presented to us, and any hypothesis that refuses

to do so must in its nature be faulty. Negative evidence may not be able to establish "the character of the life existing at any former period," but where there is a certain amount of positive evidence as to the nature of that existing life, negative evidence, at all events, will tend to strengthen the probability of the falsity of any hypothesis that does not square with the positive evidence. Mr. Mott's hypothesis requires certain forms of life to be existing at a certain period. The only forms of life of which any traces remain do not bear out the hypothesis, and the total absence of all traces of what ought, according to the theory, to exist as plentifully as those forms of which traces remain, must surely make the hypothesis untenable.

Time will only allow me to make a few remarks on another point. On page 73, we have the remark that "Carbon, like other deposits, descends ultimately to a considerable depth, and this is necessary before it can be burnt." Now, as, according to the hypothesis, this carbon is being deposited everywhere on the surface of the earth, how does it get down to be burnt? I see no explanation in the Paper of the way it descends. If I look at the strata of the district with which I am best acquainted, which is characterised by the Trias, I see no trace of carbon from the surface-soil downwards. There is not the slightest vestige of carbonised matter. It must get down in some fashion, but how?

I have been much pleased with Mr. Mott's excellent Paper, and admire the ingenuity of the hypothesis, but, as far as I can see, it is not sufficiently conclusive to satisfy me.

MR. DAVIES said, the great deficiency of the Paper was, that it gave no hint of the manner in which the state of

things existing at the most distant known period came about. Mr. Mott's views require that there must have been a time when the crust of the earth was created, with layers of coal or carbonaceous matter at varying depths, and that in some way the lowest of these was ignited. This being given, we can conceive the possibility of the rest. But this involves just as much difficulty as the view that the various strata now existing were created as they are now—a view which probably few intelligent beings hold.

If the nebular theory be true, there must have been a time when there was no free oxygen, as carbon and oxygen, at a high temperature, must unite. No known process for elimination of oxygen in nature is known, except vegetation. On this view, vegetation must have preceded animal life; and the evidence, such as we have it, agrees with this view, which is opposed to Mr. Mott's.

There is no evidence that the accumulation of carbon, alleged by Thomson and Liebig, actually takes place on any great extent of the earth's surface. In land which has been grazed for years we find only a superficial layer of soil, containing organic matter, and below this, generally rock, sand, or clay, almost devoid. The formation of coal or peat requires conditions which are far from universal; and where these do not exist the carbon produced is practically entirely oxidised.

It is in favour of Mr. Mott's views, that during the existence of life upon the earth the mean temperature of the surface must not have exceeded about 120° F. Now, as the earth must be cooling, according to Professor Tait, ten millions of years is the utmost that can be allowed for the geologic changes since life existed. As this is not enough, there must be some means by which the cooling is compensated, and this may be that pointed out by Mr. Mott. This theory may, therefore, supplement the nebular theory, but cannot,

I think, overturn it, and therefore leaves Haeckel's views untouched in this respect.

MR. MOTT'S REPLY.

Confining myself to the questions in debate, but with a hearty appreciation of the friendly nature of the criticisms, my reply will be as follows.

I shall say little on the theological view of the matter. It was not my object to discuss the question whether the complete doctrine of evolution is consistent with any, or, if so, with what, theology. Haeckel himself asserts an absolute atheism to be the necessary result of his own theories. Similar views, more or less complete, are widely spread among the more advanced school of evolutionists. The reasoning on which they are founded is powerful. The difficulty of replying to it is clearly shown by the nature of the various efforts made in this direction. I have assumed that these facts are sufficiently grave to make a fresh examination of the evolution doctrine necessary. If that doctrine is itself unsound, we need not trouble ourselves further about its theological consequences. I will, however, add one or two general remarks.

No view of the material universe, however mechanical, is inconsistent with a belief in a Creator, unless it asserts the eternal existence of matter and its laws. If any beginning is believed in, a cause for that beginning has to be assumed: and if a machine, once made, will go on for an indefinite time by its own mechanism, the mechanism will never account for the machine; and purpose and plan might be as clearly proved by its construction as they could be by any subsequent interference with its movements. But purpose

and plan are forms of intelligence. If intelligence is only the passing product of the clash of atoms, *a fortiori*, this is true also of plan and purpose. If so, the material universe must exist before these can be produced, and to speak of them as concerned in calling it into existence is, of course, absurd.

If trust is reposed in any promise that is made, the only rational ground for it is the belief that the being who makes the promise possesses certain moral qualities. But to say that any being possesses moral qualities, is to say that he is an intelligent being; and if intelligence is the product of the clash of atoms, so also must these qualities be. But the promise on which Christians have relied is made by a Being who declares himself the Creator of the universe, and not its product. If we do not believe the declaration, on what ground do we trust the promise?

The necessity of a material organism to the action of human intelligence is a fact of observation; but observation does not tell us why it is necessary, or how it operates. If human intelligence is the product of the clash of atoms, that is one explanation of the necessity; but if it is the product of a spirit acting on a material form, the necessity is just as clear.

I do not offer this as a complete answer to Dr. Drysdale's remarks on this part of the question, but only as an indication of the line of thought which such an answer would follow. To be complete it would necessarily be long.

It is objected by Dr. Drysdale, that I have not given my own idea of the scheme of the universe. But my purpose was to show that Haeckel's idea of it is untenable; not to propound another in its place. I believe that physical science has not yet discovered anything which discloses the scheme of the universe, but that, as in space, as far as we can

see, our telescopes show similar conditions of existing things, so in time, as far as we can trace the past, there is no important difference discernible between it and the present. Every one admits this concerning the more recent past; I only maintain that it is true up to the limit of our remotest knowledge.

The condition of the universe two thousand years ago did not explain the origin of living forms. I think the same concerning the Laurentian epoch. This is to leave the question of origin entirely open, as far as science is concerned. I myself have an undoubted belief in the reality of spiritual existence, as distinct from material existence; and I, of course, suppose that the true explanation of all vital phenomena is to be found in the action of spirit upon matter; not in the production of life by material agency; and when it is said that science cannot pretend to show the existence of any immaterial substance, but that it deals with matter and force alone, I cannot help pointing out to my friend what seems to me a contradiction in terms; for force, at any rate, is not matter, and yet science cannot stir a step without assuming its real existence.

The descent of existing forms of life from one stem, or from many, is a question of evidence, but it does not touch the true root of the doctrine of evolution, which has little philosophical importance if it cannot explain how a phylum came to exist at all. For, unless the movement of lifeless matter can produce a living phylum, there is some other power in the universe by which it has been produced; and if there is such a power, then there is an efficient cause for any vital phenomena always existing. If it required this extraneous power to create the first phylum, there is no reason to assume that only one would be created, or that a world, naturally suited for many forms of life, would be left

with only one form till countless ages had slowly changed this into many. Of course, all objection would vanish on proof of the fact, but the proof must be positive before it can be admitted. To ask us to believe it on mere speculation, or on grounds of negative evidence, is an error which Haeckel entirely avoids.

As to the form of the earth, the nebular theory, doubtless, gives one rational explanation of it; but it is far from being the only one. Among spheroidal objects made by man, a certain number are made in accordance with that theory; by the revolution of semi-fluid matter on an axis; but the same shape is arrived at by a vast number of methods. So, until we know as a fact that the earth was once nebulous, we have no sufficient reason for determining the cause of its shape. But, in fact, the earth is chiefly covered with water and surrounded by an atmosphere, and both air and ocean are constantly conveying material from one place to another. These two fluids necessarily tend towards a spheroidal form, and have done so ever since the earth revolved on an axis; and it appears certain that their joint action must have given this form to the solid crust in the course of ages, whatever its previous shape might be. This is Lyell's conclusion, supported by Playfair and Herschel. (*Principles*, 10th Ed., vol. 2, p. 199.)

I do not say, or believe, that "there never could have been a time when the number and variety of the species of animals and plants could have differed materially from what now exist." That would be to predicate eternity, not only of matter itself but of its present distribution. I only say, that the present condition of things existed as far back as our knowledge extends. This is fatal to the doctrine of Evolution, not only by depriving it of all evidence in its favour, but also because we see far enough back into the past to say that if the essential

differences between living forms have been permanent through that vast period of time, there can be no ground for believing that the higher forms are descendants of the lower. The true origin of these forms and of their differences remains a question which physical science is not yet able to solve. The field is open for any theory sustained by proper evidence, and not inconsistent with the actual facts; for a theory of direct creation, for example, if proof is forthcoming, and the date assigned to it is sufficiently remote.

On the question of the interdependence of plants and animals, it is necessary to observe exactly what the evolution doctrine requires. The earth's crust contains a prodigious quantity of carbon, of undoubted organic origin. If this had been derived from an atmosphere of carbonic acid, the liberated oxygen would have been many times greater in quantity than it is, or than it can ever have been while any air-breathers have existed like those of the present day. If it was derived from some other compounds of carbon, the nature of those compounds must be explained, their presence in sufficient quantity must be accounted for, and the result of their decomposition shown to be not at variance with physical facts. We mislead ourselves if we rest on the supposition that some unknown organism, living on some unknown food, could account for the carbon in the earth and the gases in the air by some method which cannot be explained. The composition of the atmosphere has certainly not been altered while the mammalia have flourished. The deposition of carbon has gone on during that period, in the usual manner, by the operation of known causes, without disturbing the general balance. What reason have we for thinking it was otherwise in the carboniferous age?

The three points referred to by Mr. Morton are of great interest, but on the second there is no great difference

between us. On the other two, I must make some remarks.

The date of the earliest insects was put back from the Carboniferous to the Devonian era in 1865. In the same year the *Eozoon Canadense* was announced in the Laurentian. Mr. Morton's suggestion that there were no fishes in the earlier Silurian era, because none have been found below the very highest beds, is one of those inferences to which I am obliged to give an unqualified opposition. Our knowledge of the conditions of Silurian seas is totally insufficient to enable us to say whether fishes would or would not be likely to be preserved as fossils in those small portions of deposit which have been examined. I must dissent also from the theory that the results of vital action can be measured by the amount of limestone in any series of beds. Silicon, magnesium, iron, phosphorus, sulphur, potassium and sodium, are found in nearly all organisms; and most other elements are occasionally present. And that deposits due to vital agency are perpetually falling over the entire ocean bed, is a fact admitting of demonstration. The mineral matter which flows day and night into the sea in solution is certainly deposited, and it requires vital agency to extract it from the water. The quantity brought in this way from the land is, on a low estimate, equal to several cubic miles of rock every year, and the total quantity dissolved by the sea itself is probably still greater; for waves are dashing always on every coast, stirring up the mud, grinding the pebbles, devouring the cliffs, and of course dissolving whatever is soluble all the time; and the material brought in mechanical suspension by rivers, is subjected in the sea to the same action as it slowly subsides; and the sea is constantly provided with fresh carbonic acid, which increases its power as a solvent, not only by the rainfall on the ocean itself, but from the living bodies of marine animals. The vast quantity of

matter thus dissolved is all precipitated again, for the ocean does not grow saturated, and this is all due to vital action. A total deposit of ten cubic miles a year from this source, which is probably less than the truth, would fill up all the existing oceans in less than fifty million years. If geologists dispute this reasoning, they must explain how the dissolved material is got rid of after reaching the sea.

Mr. Ward repeats the usual statements as to the geological succession of progressive forms. I will ask him to consider the following facts :—

According to Lyell—

It cannot be said that the successive development of higher and more complex structures is by any means conspicuous in that grand branch of the animal kingdom (the Mollusca) which is most largely represented in a fossil state. The history of Fish imparts an idea of mutation rather than of progression. The Reptiles have long been retrograding. (*Principles*, vol. 2, chap. 9.) These are the chief forms of animal life of which geology gives any lengthened and continuous history. I will add, that if we search the cretaceous rocks, we find no mammals, but if we go back to the Oolite, their remains are discovered. The highest animals are found only in recent rocks ; but it is only in recent rocks that the places where their bones are deposited at death can, except by rare accident, be preserved.

It is very satisfactory to me to find my friend, Mr. Higgins, admitting that my reasoning as to intermediate forms is logically unanswerable. Zoologically, however, he thinks that much may be said in reply. For “the differences or affinities of living things cannot be treated as you would treat terms in a syllogism.” I fully admit this. The work of the actual observer has a special authority of its own, so far as it really goes. But I think that in the use of the

phrase, "differences or affinities," my friend shows how strongly the observer may be unconsciously affected by the habits of thought around him. For what you really observe is not difference or affinity; it is difference or likeness. The word affinity means more than this, while nothing more than this comes under your observation. You do not see the derivation of forms; you only see how far they resemble each other. Now, when two living individuals are extremely like each other, we know that one of two things is true; either they are the offspring of the same parent, or else their parents also were very like each other. If we know nothing more, the probability in favour of the second alternative is of course millions to one. The likeness between the parents also is often a little less, and is not by any necessity a little greater; so that no retrospective view will make the fact of likeness real evidence of anything further. Doubtless there are cases where a group of facts produces in us a strong conviction that a particular kind of animal, not now existing, must have been the ancestor of an existing species, as in the case of the Hipparion and the Horse. But in such a case the zoological observation which establishes the likeness and the peculiar nature of the difference, is not the real evidence of derivation; that, if found at all, is found in other circumstances. If it is proved that the Hipparion lived formerly, and does not live now; that the Horse, living now, did not live formerly; that at the era of the Hipparion there was no other living thing that could be the ancestor of the Horse, and that at the present time there is nothing but the Horse that could be descended from the Hipparion—and if similar facts are proved concerning the intermediate forms of progressive change—then, indeed, the proof is conclusive; but it rests, in such a case, on these external facts, and not on the zoologist's special knowledge.

In stating that no individual is exactly like his distant

progenitor, I do not overlook the fact that the "progenitors" are in each case not one, but many. But what is true of one is true of all; and the zoological "identification" of one individual with another means the observation of likeness between them, simply and solely.

On the question of the deposit of carbon in the ground, I will add some further explanation. I have estimated the annual deposit as equal to three hundred tons of carbon per square mile, or half a ton per acre. Where, then, is this to be found? This half ton per acre is washed every year by at least five thousand times its own weight of rain. Of course the greater part of it is washed away into water-courses; it floats into rivers, and thence into the sea, and there becomes deposited along all the coast lines in the world. Most vegetable matter sinks in water after it has become saturated and partially decomposed. The continental coast lines exceed one hundred thousand miles in length, and the breadth of river deposit round them may be taken at two hundred and fifty miles. There is, therefore, a marine area of twenty-five million square miles, equal to half the land surface, on which the carbon brought by rivers becomes spread. Generally, it is mixed with mud, of which it forms but a small percentage, but in many marshy estuaries it is caught by growing vegetation, and collected in large quantities. This coast line, therefore, receives the great carboniferous deposit of the age. It is a ribbon-like band, following in all directions the continental outline, with frequent patches of large accumulation, occurring all over the world.

Another large portion of the carbon falling on the surface is washed, not into rivers, but into all low-lying and hollow places in the land, where it accumulates, in deep patches of vegetable mould, over limited areas; and another portion remains spread over the surface generally. If the latter were

one-fourth of the whole deposit, it would add about an inch to the surface soil in a thousand years; and though in many large districts no such addition can have occurred, I do not think this can be said of the world at large. The surface soil is subject to very frequent disturbance, and is re-laid by nature continually, and the portions removed from time to time become deposited afresh in modes too various to be traced. Wind is another agent by which large quantities of vegetable matter are constantly being removed from the place in which they fall and driven together into masses.

Considering the vast area of the ocean deposit, and the great number and frequent thickness of vegetable accumulations on land, it seems to me that the estimate I have made is at least sufficiently accounted for.

There appears to be a little misunderstanding about the descent of carbon into the crust of the earth. Like other deposited material, it descends only in the ordinary course of geological change. That it has thus gone down in prodigious quantities, and in all known epochs, is an established fact. In the work on Coal and Coal Mining, by Mr. Warrington Smyth, F.R.S. (3rd Ed., 1873, p. 21), a single page gives a table of the position of beds of fossil fuel known to exist, showing their presence in every group of rocks from the Pliocene to the Silurian. Nor is there any reduction in the scale on which such deposits have been formed in recent times; there are tertiary lignites in Austria with seams of brown coal more than one hundred feet in thickness. (Smyth p. 85.) And fossil fuel, in the ordinary sense, is probably only a small part of the actual carbonaceous deposit. Coal is only formed when great masses of vegetable matter are brought together with little mixture of anything else. When mixed up with other mud, as on the greater part of the coast line, the beds ultimately formed will not be beds of coal, but ordinary rocks impregnated with carbonaceous matter, such

as bituminous limestones, and innumerable shales. The production of a true coal bed requires a combination of special circumstances by which unmixed vegetable matter can accumulate in the same place through long periods of time, and can then be carried down by gradual subsidence to a considerable depth. The mode in which this can happen will alter from age to age, the chief modifying circumstances being the geographical and climatal conditions of the period. At present the places where such accumulation appears to be going on, are principally peat mosses and the deltas of some rivers. But vegetable matter diffused through ordinary rock, though not combustible in that condition, may easily become so. At a sufficient temperature it will yield petroleum by partial decomposition, and the liquid hydrocarbon, filtering through in the earth's crust, will collect together, and will then be as available as a bed of coal for subterranean combustion.

The quantity of vegetable matter oxidised on the surface, by the action of the lowest organisms, cannot be accurately determined, but there are manifest limits beyond which it cannot go. The necessary oxygen must be provided. It does not appear that Bacteria or Fungi can provide it by the decomposition of water. The oxygen in the vegetable matter itself is only sufficient for the combustion of a small part of the carbon, and that of the atmosphere is only available where it has free access. But the greater part of the fallen vegetable matter is soon washed out of contact with the air, and its complete oxidation becomes then impossible by the agency in question. Dominica, to which Mr. Higgins refers, is, I believe, a small hilly island with plenty of streams, and is, therefore, one of the least likely places for vegetable accumulation.

In the above observations I have already replied in part

to the remarks of Mr. Davies, who, however, is still disposed to favour the idea that there was once no free oxygen in the air, and that its subsequent liberation, as well as the deposit of carbon in the crust of the earth, were due to the action of plants which existed before animals, and decomposed the atmospheric carbonic acid. I think this view is rendered improbable in the highest degree by a consideration of the actual quantities. The carbon now in the ground could not have been thus deposited without liberating a quantity of oxygen enormously greater than the quantity now existing in the air. If the figures I have given are carefully examined, it will be seen that in all probability the actual quantity would be many times as great as the entire atmosphere. The hypothesis, therefore, cannot be admitted till we have some rational explanation of the mode by which this surplus oxygen could be removed.

It must also be remembered that all known organisms, plant or animal, require more or less oxygen in order to live, and that if they do not get it from the atmosphere, or from air dissolved in water, it has to be supplied by separation from compound substances to which they have access and which they are able to decompose.

I will add, in conclusion, that while I cannot claim the direct support of Sir Charles Lyell for the general theory of my Paper, the views laid down in the *Principles of Geology*, chapters 11 and 27, are in harmony with a considerable part of it, and are fundamental to the rest.

ON SOME PHASES OF MODERN FRENCH THOUGHT.

By J. BIRKBECK NEVINS, M.D.

DURING a recent visit to the South of France, I picked up sundry books at the railway stalls, and was interested in some cases, and surprised in others, at the indications they gave of tones of thought which I had not anticipated. The fact of these books being found on the railway stalls seemed to indicate that the sentiments they expressed were also more or less popular; for not only were there authors to write them, but purchasers for them when written, and these sufficiently numerous to meet the approbation of such caterers for the popular taste as railway stall-keepers. It may be that these forms of French thought will be more familiar to the members of this Society than they were to myself; but if this should be the case, we shall still, I trust, have the subsequent discussion, which often proves even more interesting than the paper which has given rise to it.

The works I have alluded to illustrate both peasant and fashionable thought, either of which alone would be an imperfect representative of national feeling. They are entitled "Contes Merveilleux," or, traditional fairy tales, current among the peasantry on the borders of the Lake of Geneva; "Les Petites Misères de la Vie Conjugal," by Balzac; and "La Confession," by Jules Janin. I shall commence with the first, and give a slight outline of one of its most thoroughly rustic stories, which is, on that account, one of the best illustrations of peasant thought. The story is entitled "Pommes de Pin."

"At the season when fir-cones cover the soil of the forest, Corasan went every morning, *by order of his*

mother, to gather a large sackful. He would willingly have dispensed with this work, for he was a strong fellow for his age (he was about twenty-five years old), but he always obeyed—for, *in this country, a man does not think himself relieved from filial submission as soon as he has a beard to his chin.*"

Now an English writer of romances for the artisan class would never think of beginning his story with such an introduction as this. But the tale proceeds to relate that one day, as he made his accustomed collection of fir-apples, he exclaimed to himself, "Oh! if some good fairy would change them into gold." He had scarcely uttered his wish, when a fairy appeared, and said that it should be granted the moment he reached home, if only he did not think one single bad thought between the forest and his house, and he should have six days to try in.

He was delighted with the promise, and returned home at night full of anticipations; but, alas! the cones rolled out of his sack cones still, with no sign of gold about them; a disappointment which the fairy explained the following day, by telling him that as he went past his landlord's house he had said to himself, "Ah! my fine fellow, for as grand as you think yourself, I shall be grander than you soon." The next day brought a similar disappointment; and this time the fairy charged him with having put a few cones into his pockets, and with having said to himself, "When the fir-apples are changed into gold, I shall have some for myself, which I need not divide with my brothers and sisters." Another day he failed from having said to himself, when passing the hut of a poor man almost bed-ridden with rheumatism, that he ought to be ashamed of himself for having it in such a dirty state. And the last misadventure arose from his turning aside up a by-path in the forest, to avoid meeting a poor girl called Colombelle, and saying to

himself, "My mother forbade me to think about Colombelle, and I ought to obey my mother." "You hypocrite!" said the fairy, "when your real thought was that in future she would not be good enough for you, as she was too poor now you were going to be so rich." The unfortunate sinner, with tears in his eyes, acknowledged his fault, and begged the fairy to leave him as poor as at first, if only, "Oh! good fairy, you will make my mother give me Colombelle for my wife," to which humble petition the fairy answered, "Go home in peace, and when you have emptied your sack, go down upon your knees to your mother for this favour." And the story ends with a picture of the poor *méchant* upon his knees, entreating his mother to give him Colombelle for his wife, and, while in this attitude, hearing the sound of heavy balls rolling about on the floor, for his fir-cones had all been changed into gold, which he shared equally with all his brothers and sisters, reserving no more to himself than he gave to each of them.

We cannot conceive an English writer constructing a story upon such a basis. Obedience rendered to a mother, unwillingly it is true, but still as a complete matter of course, by a sturdy young fellow of twenty-five, and its being a self-evident fault to wish to be richer than his brothers and sisters, even as the result of his own work. The equal division of family substance is known to be the LAW in France, but I had not realised that the principle was so engrained in the French popular mind as it appears to be from this story. In conversation with a French friend, who has occupied a distinguished position in France, and is also well acquainted with English society, he expressed his conviction that it was the still remaining tie of family life, which was the one hope of safety in French political and social life. And, at the recent Social Science Congress, the author of the paper on the improvement of the land

laws dwelt strongly on the influence of the division of the land among the family, in creating an immense number of small proprietors, each interested in the welfare of France, and in making his own little plot of land as productive as possible. The universal thrift and industry, thus kept active, have produced the universal savings among the peasant population in the country which have always been ready to supply a Government loan, and have contributed to that spectacle of French resurrection which has astonished the world.

The prayer of the poor peasant to his mother, to procure him his wife, has its echo in the more fashionable circles depicted by Balzac and Janin, the latter of whom briefly says that his hero, having tried many times on his own account to find a wife, but without success, at length entrusted the search to his mother, in these brief words, "Anatole remitted to his mother the choice of a spouse. This is, indeed, an office for a mother. It needs a woman to understand a woman, and a mother is seldom deceived."

The principles and process of selection, according to modern French ideas, are more fully developed by Balzac, who gives the following as the orthodox plan :—

A friend speaks to you of a young person, good family, well brought up, pretty, and having 300,000 francs, and your wish to be introduced to this charming object results in the following conversation: "A charming evening," you say. "Oh, yes, sir," she replies—and you are admitted to court this young person after the following preliminaries have been duly discussed by the two families :—

The gentleman's family see in the charming young person—

1st—A young lady, and,

2nd—An only daughter, who will therefore inherit—what? Something from her mother, and something from her father.

FROM HER MOTHER—who ought certainly to inherit something from a gouty old uncle, whom she coddles and flatters, &c., and also from her own father. Caroline, our heroine's name, also flatters and pets her uncle, and her chances upon the whole may be reckoned at—well—say 200,000 francs.

The respective mothers-in-law compare notes, and agree that there is no probability of further little Carolines, and the gentleman receives permission from his mother. "You may marry Caroline, for she is sole heiress to her mother, her uncle, and her grandfather."

HER EXPECTATIONS FROM HER FATHER are, that her grandfather is an old man in his dotage, and therefore the succession cannot be disputed, and may be reckoned at 300,000 francs. Her father is a fairly preserved man, but as he made some havoc of his constitution when young, he cannot wear for ever, and his only sister is an invalid, and will soon be translated from earth. Caroline is therefore an eligible partner, and the gentleman's mother allows him to court her.

On the other hand, the gentleman himself will, "some day or other," inherit from his father—so much; so she also is allowed to accept his addresses. Meanwhile the two families have had a little delicacy in discussing money matters, but they are eventually settled by two notaries, and "then," according to our author, "the two families think it necessary to invite you to go before the Maire and to Church"—as if it was an idle and unnecessary formality—to be succeeded by the wedding ball, at which both bride and bridegroom are present until the dawn of the following day. I shall spare you the description of the ball and its accompaniments, merely observing that the account given of it leaves us nothing to regret in our English fashion, which sends the newly-married couple on a wedding tour, and leaves the ball to be enjoyed by others while they are far away.

But the sequel of this wedding ball is the point upon which the interest of the most earnest and interesting of these volumes turns throughout. The bridegroom, under circumstances partly natural, and partly of the most extravagant unnaturalness, according to our English ideas, accidentally strangles his bride the first night. No suspicion attaches to him, except in some obscurely-hinted manner by a tall, stern man, who comes to view the body, apparently from the police. But it is necessary now to give a slight sketch of the hero of the book, who is called Anatole, which I do in the words of the author. "His family was rich, and, in this age of equality, was proud of a great name, without any one being able to mock at it for its pride." "Like nearly all the old families of France, it had the consciousness of its weakness and of the vanity of regrets, but still it carefully preserved these vain regrets as if they were an ornament." "Anatole was a man of the new world—simple and good, thoughtful and ambitious. By his tastes, his habits, his profound work, and his advanced intelligence and little leaning to enthusiasm, he belonged entirely to the new generation—a young and strong party in the political world, which is in haste to live and to learn, because it has a confused perception that there is need for it, that everything around it is dying, and that one ought to live quickly to be soon replaced, like a transition people."

"Society is now so constituted that there is only one life, viz., the political life, for a man of large thoughts. Everything else is forbidden to him under pain of ennui and mortal disgust. There is no room for emotions or interest—the purple of empire has lost its charms, the general's uniform inspires no ardour, and only merchant vessels crowd our ports; the profession of a savant is impossible, for intelligence advances every day to a frightful equality. There are no more ambitions of l'Œil-de-Bœuf, or animated intrigues of Versailles, to distract us. The time for being young has

passed away." "Now political life does not commence before forty, and there exists, therefore, between the two conditions of youth and of being a citizen, twenty years of waiting and study, during which one can hope for no other recreation than marriage. Anatole therefore consented to take a wife. His parents wished it, though, for himself, he did not see the necessity for it. But, however, jokes about husbands are worn out, and no one is now afraid of them." So he married, as we have seen, with the melancholy catastrophe already mentioned, and "his future was destroyed, the world was desert, he would henceforth be alone, and he would give all, all for one single hour of repose, which always fled from him." A painful description then follows of his vain attempts to obtain freedom from remorse, and he often thought of giving himself up to justice, but the disgrace it would bring upon his family, not apparently any particular shrinking from death itself, deterred him. He became, however, so impressed with the idea, that he constantly attended executions, for he said, "Am I not like that miserable wretch, except that he pays his debt and is quits with justice? He pays for his crime, body for body, while I am a coward and a liar."

After long and vain attempts to obtain rest, he "is at length driven by the force of his sufferings to abandon himself to thoughts which are not born of earth;" and here the principal interest of the work appears to me really to commence—exhibiting feelings which I had little idea would find so prominent a place in a railway-stall shilling book. "It was at first a vague and confused religious idea, a mere caprice; then it gradually became a necessity, and, in spite of himself, he began to find that he was straining forward to this last hope for calm and repose."

"At first he recalled the faith of his earliest years, so lively and pure, and his infantile joy when, at the first silvery sound of the bell, he set out for the village church on Sun-

day, so proud of giving his arm to his grandmother. That day always had an air of festival and calm; all the women wore their best dresses, and the men had on new clothes. To reach the church it was necessary to cross the churchyard, a little field sown with poppies and wooden crosses. He must pass through the crowd to reach his chosen place in the choir, and in the choir he knelt by his grandmother, and prayed with her in a loud voice. Then, when the religious chants were sung, he prayed aloud and sang like the others, but he sang with the women, and his infant voice accorded well with theirs. Then arrived the pastor, preceded by the Swiss with his innocent halbert, and then came the last adieu of the priest, after which the whole crowd dispersed in silence; and there were cries of joy when they had passed beyond the cemetery, each inhabitant standing at his door with a pleasant look and a cordial salute; and the old sacristan offered the holy water to the guests before the meal, and the evening passed in country dances. He recalled the smallest features of these fairy times, and you may think with what regrets."

"One night, when he had been more distressed than usual, he found himself gazing for an hour upon an ivory crucifix, which had been a present from his mother, and as he dwelt upon the crown of thorns and the drooping head, he felt too miserable for longer shame, and he determined upon what he had long irresolutely wished—to repent like a Christian. He rose from bed, and, wrapped in his dressing-gown, aroused his wondering valet, and desired him to make all haste in calling for M. l'Abbé Paul. 'If he sleeps, wake him; if he says he will come to-morrow, beg him to come this very instant; if he asks who sends for him, say it is I; and if he does not wish to come till the morning, tell him that some poor fellow is dying, and he will come, he will come quickly.'"

"Anatole had met the Abbé Paul in society, and had

loved him from the first. His whole person commanded confidence—grave without austerity, learned without pedantry, polished without insipidity, his mouth was full of wise and good words, and his heart was full of charity. Various stories were abroad about his wild and violent youth.”

“He had been one of the bravest soldiers in the French wars, and he had become a Christian for the love of repose, and a priest from philosophy; thus he fulfilled the first laws of the priesthood—to see much, to suffer much, to know much, and lastly to pray much.”

“Anatole had a moment of hesitation after having despatched his messenger, and accused himself of feebleness while figuring himself as a penitent before the priest, whom he had hitherto known merely as a companion. To confess himself! He! a man of the nineteenth century. He! to say to a priest that he had sinned, and to accept his punishment with fervour. He had often seen, during his vagabond courses, poor women on their knees on the stones round the tribunal of penitence, waiting with clasped hands for their turn to come; and he had remarked their subdued joy and light step in leaving the church, but never had he thought that it would come to him to ask those unhappy women for a place by their side; never had he imagined that he would go to place himself at that wooden grating which separates the penitent from the confessor; and yet what a difference was there between him and these good women, between his crime and what they had to tell.”

“His nurse, for example—so good, and so gentle and patient—this woman who had brought seven children into the world, of whom five had been killed in battle, and who now worked all alone in order to support her aged husband—this good nurse, who had worked all her life as no beast of burden works, and who had never refused to open her door to a man pressed with hunger—what has she done, that I should

come to dispute with her for a place where she would be astonished to see me? What can she have to tell her judge? What crime had she committed? And if she has reason for coming to the confessional, if she finds some benefit from resorting to it, why then should not I—I, so miserable—who so little resemble her?"

While this conflict was passing through his mind, the Abbé arrived. With an embarrassed air, "What do you wish?" said he. "How can I be so happy that you have need for me? What can I do for you? Speak, sir, and make use of me—I am entirely at your service." "Alas," replied Anatole, "I have so many things to say that I do not know how to commence. If you knew how I have suffered this night! I imagined that by seeing you I should be solaced. Pardon me, I pray, such a sad indiscretion—pardon me as you would pardon a sick man struck with death." The Abbé was dumb. Was this the same young man whom he had seen in society, so loved, so honoured, with such a future before him? Anatole understood him, and replied sorrowfully, "It is I indeed who have called you this night, who wish to see you; yes, you, my Father, who wishes to seek from you pardon from heaven, who wishes to confess to you, my Father; it is the same Anatole whom you have seen so proud of his knowledge and of his wit. See me, and listen to what I am going to reveal." "You at my feet!" cried the Abbé, and his voice trembled and his knees shook. "You! treating me as a priest. You! depositing in my bosom the secrets of your life. Stay, stay! How do you know if I am worthy of your confidence? How do you know if I am able to receive your secrets? In the name of heaven, hear me, and know what I am—be calm." "I am calm," replied he, "and wish to confess to you a great crime, in order that that may happen which our religion wishes, for I am a Christian like you, and

I have a right to your prayers, and a right to your blessing." "Anatole," replied the Abbé, "I wish to know if you speak to a man or to a priest; the man is perhaps worthy of your confidence, and you shall have my counsels as a friend"— "I do not want a friend," interrupted Anatole; "I want a confessor. It is not you, sir, whom I have called, it is the priest, and the priest only, with power to liberate in heaven those whom he frees on earth; the priest with pardon from on high; I desire the benediction of a priest, the pardon of a priest, the penance of a priest, for my crime is great, and there is need of great power to pardon me." At these words the Abbé stood confounded, but, after a few moments' silence, said, "You see me as unhappy as yourself, for what you demand of me is impossible. Pardon me—me, who have never known fear—your confession terrifies me, and I tremble to bear so heavy a burden. Once more, I am only an honest man, nothing more than a friend. I could weep with you, and pray with you, but to lay hands upon you, and become your judge; to pronounce your sentence in this world and the other, no! no! no! my God, the task is beyond my conscience and my strength. No, I am not invested with a character so sacred as to dare to sustain, 'face to face,' the terrible avowal that you would make; I am not a priest for you; on my soul, sir, I have not the right."

"It is just as I thought from the first," said Anatole, with a bitter laugh. "I well knew that your black robe was all trumpery, and that the remedies for remorse which Christianity promises do not exist, and are only an empty lie. I am obliged, sir, for your not wishing to lie to me." "In this case," said the Abbé, "you may believe me that they are not vain remedies; for myself they have cured me of my life as a soldier; but the deeper the wound the more skilful should be the physician, and I do not think myself skilled enough to cure you.

I am still too much of a man—a man such as I was before—to be only a priest; you want a priest, young man; seek for him. To-day priests are rare. Priests are born, not made. Seek a priest, and confess your crime to him; but to such a man a heart of steel is necessary, a hand of iron which may press upon you, an inflexible voice which may crush you. You talk of a confession. Ah! believe me, that in all the acts of our life, to make a confession, or to receive one, is the most difficult. It is necessary to be either less than a man or more than a man; wait still longer. Perhaps you have not yet suffered enough to be sufficiently patient. Wait, and you will find a confessor when the time shall come.” And the Abbé left the house full of tears and of regrets, for he had now learnt to comprehend how little he had attained to the height of his priestly office and of his painful duties.

“Surely,” thought Anatole, after this first refusal, “there must be among so many clergy some man strong enough to hear me, and to absolve me;” and he hoped yet to find him. In former times it had been a subject of lively interest to him to enquire what is the depth and secret of the Catholic priesthood. He sought to know by what law the Roman clergy guides itself, beaten by so many tempests, exiled and wandering without asylum through Christian Europe, to return at length in the midst of beliefs broken up, to return alone, without help from Rome, having lost its property, one of its former ornaments, and having no more influence than a retired veteran admitted to some retreat.

“The singular position of the Clergy is a thing well worthy of remark. On one hand, the venerable relics of the French clergy, as unfortunate as royalty itself when it was banished,—these old priests, born to gold and purple, kings in their cathedrals, men of devout and gentle life, martyrs escaped from massacre, and returning at length in the train of the

king,—to these there remain only peace and sleep; they are no more than a memory among the clergy of France. But, on the other hand, and opposed to these old clergy of proud and noble origin, a young clergy rises up in our day, without cohesion, without family, and holding no social position—poor distracted devils, who seek the Sorbonne on leaving St. Sulpice, and who find philosophers and profane orators in the Sorbonne, and not a thesis to maintain—who ask, ‘Which among us is rich?’ and remain beaten down in a common silence. But when they mount the holy pulpit they find that the word escapes in the pulpit. There are no longer sarcasms against the faith—the air of philosophy has ceased—men are ashamed to mock a priest; they have become citizens like ourselves, citizens though priests, and, thus afflicted, they have become the means of reconquering so many lost privileges!”

During his search for a confessor, Anatole found himself near the door of a vast cathedral, and noticed with pleasure how little he was by the side of the least of its doors, or the smallest of its stone-carved saints; and he thought that if he could but enter there, and go out after being blessed, perhaps he should find repose and happiness. But, meanwhile, the various acts of the daily drama, called life, passed on. An infant lately born was carried by its nurse; its father waits to inscribe its name in the municipal office, but there the course of the newly-born stopped. It was carried to the Maire, and it repassed the Church without entering it.

There was a fashionable marriage, and the coachman in white gloves, and the parents, and the bride and bridegroom went to the Maire. At his door they found all the poor who, of old, besieged the door of the church; and they also returned in front of the church, but without entering it. Death itself disdained the old refuge, and the prayers over the coffin, and the holy water sprinkled over the black cloth

watered with tears. The bier was carried silently, and silently followed by the friends of the departed, who inscribed his name with the Maire; but his body passed in front of the church, and did not stay there.

This was what the young man saw, and he could not comprehend the strange duel between the religious and the civil law. He asked in vain from what cause the power, which at first was all on one side, had passed entirely to the other, and how it came to pass that no one desired to make use of a monument so beautiful, so grand, so ancient, and so holy, in order to go with the crowd to the abode of the Maire, in a vulgar house, without perfume, and without memories.

By chance one day there was a religious procession from a church, and one bearer did not arrive. The priest was in despair, when Anatole hesitatingly offered his services, which were gladly accepted. At the close of the ceremony he observed the meditation of the pastor, his clasped hands, his eyes modestly raised to heaven, and his benediction of the people. "If only this man could hear me," thought he. "If he could bless me—all alone. If only my remorse would afterwards sleep." But this time also the unfortunate man was not heard. The ceremony was scarcely finished when a choir boy came to say that the Curé was ready to hear him, and he went away, staring with all his eyes at the Monsieur who wished to confess. The sacristy was all in disorder, and the Curé was putting away the vestments and silver cross. "Oh! heaven," thought Anatole, "my confessor so tranquil when on the point of hearing so great a crime; to pass so quickly from the pious ceremony to his vulgar cares, and from these to me a sinner, who calls him, and who prays. Me! a murderer, to have to wait so long for a word, a consolation, a penance. What importance can he then attach to confession!" Anatole felt his present coolness when compared with his manifest anxiety when a bearer was wanted for his

procession, and thought, "Perhaps he despises me now that I wish to confess." He remained for some time in anxiety difficult to express, and was then told that Monsieur le Curé had gone home to dinner, and he must come next day.

He now resolved to seek a Confessor in every rank and degree of the clergy, from "the Cardinal clothed in purple, a Christian prince and a profane philosopher, to the simple village curate, humble and poor, who hides himself, and lives retired and modestly, as useful often as a sister of charity." But he found no confessor among them all. Some appeared to him to be wanting in faith, and others in intelligence, so that in this state of mental disquiet, from which he could not escape, he began to draw the conclusion that the Catholic faith was feeble and worn out—that old age, which has given the death-blow to so many religions, and so many empires, had laid its iron hand upon our religious beliefs, and that its faith was a vain and ridiculous faith, for which one could only blush. But the unhappy man checked these mournful thoughts in his soul. He had too much need of religion not to believe, and not to desire a belief at whatever price. At length he heard of a Spanish Abbé, of extraordinary reputation and difficulty of access. After adventures which may be passed over, he at length discovered him in seclusion (for he was a political refugee also) in an attic chamber, to which by chance he was preceded by a young woman, who had also gone to confess. By concealing himself in a manner which his conscience told him was not strictly honourable, but which his overpowering desire to know the mystery of confession led him to adopt, he heard the girl's confession, which might have been uttered on the house top. But some chord was struck in the priest's bosom, for she was a Spaniard, a fellow-country woman, and evidently an old acquaintance; and when she ceased, there was a long silence, and the priest essayed to speak, but the words died on his lips. At length he

uttered, "Go—go, for I am too great a sinner to hear you. Your sufferings are mine. Go—go, or I die. Go far hence ; the suffering is too great." And she prepared to depart, with her eyes bathed in tears. Before she left, however, he gave her the address of one, "who," said he, "is stronger than I ; whose name is followed with trembling among the faithful ; a holy priest, inexorable and cruel, and who is never deceived ; the greatest Confessor in the Roman Church. Take him this letter. Perhaps he may refuse you, seeing you are only a young woman, for his moments are precious, and he reserves himself for great crimes ; but then fall at his feet, and tell him your grief, and perhaps he may deign to lend an ear to your prayers."

Surely this was the priest Anatole was in search of, and he hastened to request his aid. It happened that this night he slept tranquilly for the first time since his nuptials, and when, on awaking, he saw a tall stern man by his bedside, he asked the meaning of his presence. "You sent for me," was the reply ; "I come at your desire." But Anatole, suspecting the nature of his call, said that he felt so much better that he would not trouble him further ; and, with the greatest politeness, implied that he should decline to confess. Then his visitor sternly demanded whether he did not remember having seen him before, and Anatole, in terror, recognised the supposed police inspector of the dead body of his unhappy bride. He then plainly told the young man that he had his choice of confessing to the Maire or to the Priest, of being denounced as a murderer or treated as a penitent ; and the narrative, which I have thus attempted to bring before you, ends as follows :—"The confession was long and painful. He had at last found a confessor—a man strong enough to dominate over his whole being. Soul, intelligence, heart and mind, all were submitted to this man ; and when he departed, Anatole was still in the

same place on his knees, with clasped hands, eyes dry and haggard, prostrate and confounded."

"After this incident he was in confinement for some months, but now he is better, and his most intimate friends scarcely recognise him; calm, self-possessed, cheerful withal, smiling, happy without show, his head partially shaved, and a fresh innocence around his face. He prays, he sings, he sleeps; he is a happy man, at peace with himself and with others. He is a priest."

Such is the picture put before us of the thoughts and actions of a man moving in modern fashionable Parisian society; and the following narrative of peasant life also has impressed me deeply, from the picture it gives of family affection, of cheerful, uncomplaining fortitude in bearing privation, of the mixed sentiments of ambition and the desire for spiritual blessing with which the peasant mother desires that her son should become a priest; of the ignorance of evil in which he is educated, and his consequent innocence, but at the same time his ignorance of how to resist temptation with its consequent overwhelming effect, when he is first exposed to it, and the bitter and unrelenting punishment with which his weakness is visited. The picture, in short, that it gives of peasant religion in France at the present time impressed me strongly, and I should feel that this sketch of modern French thought was incomplete, if this, as well as the previous narrative, was not put before you.

THE STORY OF THE FRENCH PEASANT PRIEST, FROM

"LA CONFESSION," BY JULES JANIN.

Our hero, during his rambles, came to a river which he wished to cross by a ferry boat.

"The boatwoman, tall and stout, with large arms and coarse hands, a dark face and white teeth, was seated in the stern of the ferry-boat.

“ I cannot take you across at present,” said she, “ for the ‘ Angelus ’ will sound in a quarter-of-an-hour, and my little Jean, who rows instead of his father, has gone for my dinner, and I am alone, and am waiting for the noon passengers.’ ‘ Well, my good woman,’ said Anatole, ‘ I will wait for the ‘ Angelus,’ and your little Jean. Do you love your little Jean very much ?’

“ Oh ! sir; my little Jean is a man for me. He is not ten years old, and he does instead of his father. He works and sings to please me. He rises the first of anybody in the morning, and lies down the last at night, after having sung all day. Without our Jean, my husband and I should have died with hunger this winter, with the vexation about our other son.

“ ‘ Then you have another son ? Pray, why does he give you so much vexation ?’

“ Alas,’ replied the boatwoman, ‘ it is a history. My oldest son was a priest, monsieur, but is one no longer, and we don’t know what to do now.

“ ‘ And how did that happen ?’ said the young man. ‘ Pray tell me, for I am interested to the last degree.’

“ It was pride that destroyed us, sir. You see the little white house by the willow tree. We inherited that house and five acres of good land, and we should have been rich with that, but I had the idea of making a Curé of my Ambrose. I wished to have a son who would be saluted when he walked out, who would dine at the castle, and would say the mass. We have sold that pretty house and those five acres of land, to enable our boy to study. He read all the books, and was already shaved, and was going to be a vicar somewhere, when a great misfortune happened to him, poor boy. For you see, monsieur, I cannot believe that he was a criminal. He was a young man, both brave and proud ; but he had never been proud before his father,

and he always dined with me in his holidays. Oh! you wretched black-robe! what harm you have done us," and the poor woman was bathed in tears.

"The autumn passed, and the fishing had been good; the fair had made our ferry profitable, so that we had saved, my husband and my little Jean and I, twelve crowns! all good silver! 'Wife,' said my poor man to me one evening—and that evening the wind blew, and the river foamed, and the yellow leaves beat against our windows—'Wife,' said he, 'see these twelve good crowns, which will help us to pass the winter, what shall we do with them?'

"Jean did not answer, no more did I, for we had employed that money in our thoughts, my son and I. 'Perhaps,' replied my man, seeing that I did not answer, 'perhaps we should do well to buy a pig from our neighbour; the little one would suit us, it is fat and ready to kill; and, at least for this winter, we shall have some comfort in our food, and not the miserable nourishment of last winter. Not that I speak for myself, wife, but for you and our little Jean, who is growing, and requires to eat a little meat every day.'

"The last reason made me feel bad, for my youngest boy had suffered so much, that I had nothing to say in reply to his father; but our Jean answered immediately—

"'Father, don't buy the pig; I am strong enough without eating meat; everybody says that I am as big as you. I know very well, if you don't mind, what you should do with our twelve crowns.'

"'Well,' said my man, 'what then, if it is only to put us a little at ease—to buy a new waistcoat for you, my child, for you are nearly naked, and some sabots for your mother, and a little eau-de-vie for me, to warm me when I am fishing up to the knees in water?'

"I did not dare to reply to the reasons of my poor man, but Jean came to my help.

“ ‘Father,’ said he, getting up, ‘my dear brother is a priest, and he has no black gown, nor hat with three corners. It is necessary to buy him a three-cornered hat and a black gown. We will eat stale bread again this winter, and my mother will patch up my jacket.’

“ ‘Oh!—but my Jean was a fine boy, speaking thus, monsieur—but I kept on crying.

“ ‘Son,’ said the father, I have nothing to refuse you except the black gown. These twelve crowns shall be for you and your mother and me. Your brother is well fed, and well warmed; he has a bed and blankets, and as much covering as he wants. We lie on straw, covered by our summer clothes. He only fasts forty days—we fast all the year—and on Sundays we are glad to dine as he does on a fast day. Don’t speak to me about this gown and hat; don’t speak to me. I don’t choose it.’

“ ‘Alas, said I to our man, he must have the gown and hat to be a priest. Just this one sacrifice more, my good man,—just this winter to pass. Would you rather have a bit of bacon in the corner of your chimney, than your son seated higher than the singers in the church, and giving you his blessing?’

“ ‘Yes, father,’ said Jean, ‘everybody despises my brother, and asks him where his gown is. He must have a gown, father. Give him the twelve crowns.’

“ ‘The father answers. ‘If I give these twelve crowns it will be our death, Jean—take them. I give them to you, not to your brother. Your brother has ruined us; we have sold your uncle Robin’s vineyard for him, and my brother Richard’s house and vineyard, and all our fortune has gone to the seminary. You will see, my son, that I shall have to sell my nets and my boat.’ Then he turned to me, ‘Wife, wife, perhaps we shall have a priest at our death bed.’ And then he took the twelve crowns from his mattress and counted

them one by one. He sighed when he came to the eleventh and stopped at the twelfth.

“‘Jean,’ said he, ‘here is a crown for you. I want to spend it for you, Jean; you must buy for yourself some butter-cakes, and some sugar-plums, and some prunes, and some barley-sugar, and a knife with a cork-screw, and all sorts of good things. Your brother’s toys are much more expensive, my child. Go, take this crown, that it may not be said that you are the only one who has never cost us money. My sweet Jean, that your brother may not blush deeply, let us go, my son, to the fête; you shall dance, and you shall give two sous for the quadrille.’ And my poor man took his son in his arms and wetted him with tears, holding his last crown all the time.

“Oh! monsieur, but it costs dear to make a priest. They say to the parents, ‘It will cost you nothing,’ but every moment you must be paying something. You must give your poor money to a man who does not even say ‘thank you!’ and one lives on bread, and must leave one’s boats leaky, taking in water;” and the poor woman left one of her oars to bale out the water from the bottom of the boat.

At the same moment little Jean ran up and brought his mother’s dinner; the poor child was naked-footed and in rags, with a tattered man’s hat on his head, and his eyes covered by hair, which he pushed off from time to time.

“Jean!” said the good woman, “while I am eating, tell the gentleman the history of our Abbé, your brother, and don’t cry any more, my son, it makes me too ill.”

Jean put his hat on the ground, and having pushed up his hair, said, “My poor brother has told me this story three times, monsieur. He was tempted by the devil one day, when he had gained enough money to go and order his cassock. For my brother gained money, monsieur; he said masses and funeral masses, and he has often given me

money and clothes. It was he that gave me the shoes I have at home, and this hat that you see. He's very good to us, is my brother!" And this heroic lie was told with grand sang-froid by this child, who looked at his mother with a beseeching eye, for fear of being contradicted. "Well, then," continued Jean, "this is what I know about this misfortune. My brother had never gone out of the seminary. He had never walked through the streets of Paris full of iniquity—he was pure and innocent. My brother, the day he went to order his robes, took twelve crowns of silver, and went to the house of the woman who made sacred robes for the seminary; he knocked at the door, and a young girl came to open it.

"When my brother, who is for all that a tonsured Abbé, saw that the old woman was not there, but there was a young woman instead, he wanted to go back, but he did not dare; so he went in—the unfortunate fellow. When she said to him, 'Come in, please, Monsieur l'Abbé!' Then she said to my brother, 'What do you wish for, Monsieur l'Abbé?' 'I want a robe, Miss,' said he. 'What kind of robe, Monsieur l'Abbé?' said she—for she always said 'Monsieur l'Abbé.' 'I want a robe,' said he, 'for nine crowns,' for he kept two crowns for a hat, turned up with violet silk, to be presented. 'For nine crowns?' said the petite. 'You can't have a fine cloth, a good moiré ribband, a very fine neck band and full breeches. You can scarcely get a small cloak fit for a funeral. However, you can be properly dressed enough at that price; it is only necessary for us to know what you want for it to be done.' 'But,' replied my brother, 'How do they make the priests' robes for nine crowns then?' 'I understand,' said the petite; 'but then your robe ought to be fashionable, that it may show your leg, and that the cord round your waist may show your height. Something like my waistband. Look at me.' My brother, who had not

yet lifted his eyes, lifted them up. Bad luck to it! And he has sworn to me, monsieur, that this little dressmaker was all shining with fire; he could see no waistband; he only saw an infernal head. His hands were burning hot, and the girl went on. 'Sir,' said she, 'your girdle will show that,' and she put a finger upon his heart, as heavy as the finger of the devil. She stood so for about two minutes, looking at my brother all the time, and then my brother was completely dazed. He staggered, and tried to support himself, and did support himself, but he did not know upon what; but he felt under his two hands the waistband of the robe-maker who had spoken to him, and he saw no more. It was a miracle of the spirit of darkness—a phantom. My poor brother thought he was dying. The young girl forgot the sacred robes. She did not speak to my brother, and he did not speak to her. He felt his feet nailed to the ground, and he would have been there still if the old robe-maker had not entered the room, and the charm was broken. My brother, who thought he was possessed, returned to the seminary, thinking no more of his robe than if he had had two; and the next day the Superior sent away my poor brother, without bread, without a home, and without even knowing a trade. My father did not wish to see my brother. My brother is now without employment, as if it was never Sunday. They say that he is good for nothing, and his robe has not been used since that time; his robe so well made; his cord so well placed.

“Here the poor child wept, and the mother shed tears; the Angelus sounded, the labourers' wives filled the ferry-boat, and it moved away across the river.”

I have thus ventured to lay before you some phases of modern French thought, which I was not myself prepared to find on beginning the works here summarised; and if I

should venture to specify those features which have most impressed me, they would be the remarkable family unity which they illustrate in peasant life, and the calculating, unloving preliminaries for marriage in fashionable life. The tone in which the author speaks of the revival of religious longings in his hero, when in long-enduring sorrow; the respectful searching after the secret of the mysterious revival of power in the priesthood in modern times; the remarkable manner in which the office of a confessor is described as a subject of terror or indifference to its possessor, and the effect attributed to it upon the hero—a man painted evidently to the best of the author's ability, as the type of a fashionable Frenchman of the nineteenth century; and all this set forth in popular novels on various ordinary French railway book-stalls.

TYPE-FOUNDERS AND TYPE-FOUNDING.

BY JOSIAH MARPLES.

THE art of Printing is of so general and constant an interest to all in these days, that it has occurred to me the cognate art of Type-Founding may possess sufficient reflected interest to make it worth while for us to spend a little time upon it.

In the early ages of printing, a list of type-founders would simply be a list of printers, as each printer cut his own punches and cast his own type. I therefore propose to mention only a few of such names as are connected with the improvement of the art.

The original method of printing seems to have been from wooden blocks, engraved with the necessary words or letters cut in relief, and though this admitted of a freedom of design which cast types do not permit, its great cost was soon found to be prohibitory, and some simpler and less expensive method had to be sought.

The first effort at improvement was still in the same direction, and consisted in engraving blocks, or metal plates, with letters *sunk* in them, so as to print in white letters on a black ground. I have here a facsimile of a page from a book printed from such plates, the *Biblia Pauperum*, or Bible of the Poor; a catechism of the Bible, consisting of forty leaves, of a small folio size. Copies of this book are very scarce, so much so that one of them has been sold for upwards of £250. The date attributed to this book is 1430. But a brighter light was about to shine, and some six years later movable types were first invented and used, and from this time the invention of printing is usually dated.

I do not propose to enter into the controversy—never to be ended—as to who was the first inventor of printing types, further than to say that, from the records of the Court of Strasbourg, it would appear that in 1489 a trial took place between John Gutenberg and his partners, in which evidence was given that Gutenberg was the original inventor of movable types, and as this was within three years after the invention, it constitutes very strong proof that he was entitled to the honour. Gutenberg, however, if the inventor of the process, does not appear to have been a type-founder himself, as he and his partner, Faust, employed one Peter Schœffer, who, “being very expert in preparing the moulds and casting types,” received the usual mediæval reward, the hand of his master’s daughter and a share in the business. The special feature of Schœffer’s improvement was, that he made metal matrices, and so was able to cast types much more readily than before. This would imply—for we are left to conjecture upon the subject—that the first mode of casting was simply such as is now adopted in an iron-foundry, that a model was cut and moulds made from it, into which metal was run, or else that the types were cut upon cast bodies, as described hereafter. Schœffer may, therefore, be fairly entitled to the name of the Father of Type-founding.

The first important book printed after the invention of movable types—cut, not cast—was the Bible, known, from the Cardinal in whose library the first copy of it was found, as the Mazarin Bible. It contained 637 leaves, and was executed between 1450 and 1455, and it was not till 1462 that any work was issued by Gutenberg from cast types. By 1474 the ordinary roman type was introduced, and began to compete for public favour with the old black letter which we usually associate with early printed books; though the latter did not give place to the intruder without a severe and long-continued struggle.

About the same time we may date the foundation of type foundries, for we find that the types cast by two brothers, named Spira, who were printers at Venice, had obtained such repute, that printers at Rome and elsewhere advertised that they used Venetian types; the Spiras must therefore have cast types not only for their own use, but for sale to others.

In the same year (1474) Hebrew types were used, and in 1489 we find the first mention of Greek types. In 1471, indeed, an eminent goldsmith, who introduced printing into Florence, having cut punches, cast types, and printed his first book, put at the end, "Nothing is too hard for a Florentine genius." He then goes on to state that some Greek sentences appearing in the manuscript he had undertaken to print, he had left blank spaces for them, not that he had no Greek letters, but that "as many Greek scholars preferred to write their own quotations, he had thought it best to leave them spaces for the purpose." Inventing a good excuse, at any rate, does not seem to have been too hard for this "Florentine genius."

About 1474, Caxton introduced printing into England, the second edition of the *Book of Chesse* being considered his earliest production. Mr. Vincent Figgins, to whose nephew I am indebted for a copy of his imitation of this book, and whose skill as a practical type-founder entitles his opinion to great weight, believes that this book was not printed from types such as we have seen were cast by Schœffer, but from those which were cast with solid faces, upon which was cut with the graver each letter separately. To this he attributes the facts, that in the original book no pure style of letter is used, but a mixture between the old black and the letter used in manuscript books called "Secretary"; that no two letters are exactly alike; and that frequent use is made of logotypes, or types having two or more letters in combination, and contractions.

After Caxton's death, in 1491, Wynkyn de Worde succeeded to his business, and one of his earliest works was to cut sets of punches and cast types of great beauty and regularity. These types appear to have been used by all the printers of the day, and it is not impossible that the punches are still in existence, as in 1772, at the death of Mr. James, the last of the old type-founders, Mr. Rowe Mores purchased his plant, with a view of obtaining possession of these, with other curiosities of the trade. Wynkyn de Worde was the first to introduce roman type into England, and it is probable that to the great regularity and evenness of his type we owe our early emancipation from the nightmare of black letter. Pynson, another of Caxton's pupils, started in business for himself about 1493, and he also cut a new fount of roman type.

In 1496, Theobaldus, or as he was usually styled, "Aldus" Manutius, whose name is familiar to us in the "Aldine" series of books, invented italic types; and he appears to have been the first type-founder who endeavoured to protect himself by patent, as he obtained a privilege from three Popes, securing to him the sole use of this style of type for fifteen years.

In 1514, a book was printed in Arabic, in Italy, though, in 1517, a work by Dr. Wakefield, chaplain to Henry VIII., printed by Wynkyn de Worde, contained only rudely-cut Hebrew and Arabic types.

The first account of the different sizes of types that I find, is that Pynson, in 1496, was possessed of founts of double pica, great primer, and long primer, I presume in black letter, as he is also said to have possessed an english, and a long primer roman; and, in 1499, he had a pica roman, which "stood well in line."

From 1510 to 1561, Claude Garamond flourished in Paris. His types were of such repute that it is said printers

throughout Europe took care to state, as a recommendation of their books, that they were printed in Garamond's small roman.

For many years the practice was almost universal that each printer of any note acted as his own founder; but we find that, by 1637, the business of letter-founders appears to have been entirely separated from that of printers, as in that year Archbishop Laud obtained an order of the Star Chamber to limit the number of printers to twenty, and that of type-founders to four, and heavy penalties were to be levied upon any one exercising either trade without proper license. If anything could have made this regulation palatable it would surely have been the position of the licensers, who were the Archbishop of Canterbury, or the Bishop of London, and six other High Commissioners. To this order was added what would be a formidable rule now-a-days, that the four licensed founders should employ all the journeymen founders always, adding another clause which would be acceptable to the trades unionists of the present day, that none should be employed in a foundry but freemen of the trade and apprentices, except for "breaking off," as it is technically called, and for this one boy was allowed. In this connection I may mention, that in one foundry with which I am acquainted, at least fifty boys used to be employed in "breaking off." These limitations existed, having been renewed by successive Parliaments, till 1692.

MODERN TYPE-FOUNDERS.

I think we may now dismiss the printers and type-founders of olden times; but, before describing the practical part of type-founders' work, a few anecdotes of the early days of the present foundries will, I venture to hope, be interesting.

The Coryphæus of modern type-founding, as he is called

by the Rev. Rowe Mores, the most enthusiastic historian the art has ever had, William Caslon I., was born in that part of the village of Hales Owen which is situated in Shropshire, in 1692; he went up to London, and was apprenticed to an engraver of gun barrels and locks, a trade which he afterwards commenced on his own account; he distinguished himself by a skill and dexterity which were conspicuous, and which caused him to be sought for other purposes, amongst which the making of tools for bookbinders is the one of most interest to us.

In the early part of last century the type-founder's art appears to have been at so low an ebb in England that the best types were imported from Holland, and we learn that the classic works of the reign of Queen Anne were printed with Dutch types. It is not improbable that this state of things arose from the annoyances to which the law subjected type-founders, which kept men of mind and talent out of the trade, and thus did not permit any high state of perfection to be attained. Be this as it may, the fact is before us. The remedy for this state of things appears to have been discerned by Mr. Watts, an eminent printer, who having had occasion to use some of the bookbinders' tools cut by Caslon, discovered in them sufficient indications of talent to lead him to think the time had arrived for the resuscitation of the art with which he was more immediately connected. By the promise of active support he endeavoured to induce Mr. Caslon to start a type-foundry, and in 1720 the Society for the Promotion of Christian Knowledge, anxious to print a New Testament and Psalter in Arabic, engaged Mr. Caslon to cut the punches for it. When the specimen was issued, Mr. Caslon cut his name in roman, to put at the foot of the page. The form of the roman type was so good, that Mr. Palmer, another eminent printer, asked Mr. Caslon to cut the whole fount, which, when complete, excelled the productions

of any of the existing foundries. Up to this time, Mr. Caslon appears only to have cut punches, but his success with these was so great, that Mr. Bowyer, Mr. Bettenham, and Mr. Watts lent him £500 to start with, and he applied himself to his new business with such assiduity that in a very few years he had driven the Dutch types out of the field—nay, he even exported types to the continent. He erected a foundry at the rear of his residence, in the fine open neighbourhood of Finsbury-square, and when he removed to a “country house,” in Bethnal-green, his late abode was added to the foundry, which still exists and flourishes. Here, once a month, on the Thursday nearest full moon,—that his guests might have the benefit of the moonlight for their walk home,—Mr. Caslon, who was musical, and had an organ in a large room, which he called his concert-room, held a musical evening. Catches and songs of Purcell and other masters were sung, and about twelve o'clock his friends retired, having first been refreshed with a bottle of wine or some good ale of Mr. Caslon's own brewing.

His son, William Caslon II., succeeded to, improved, and extended the business left to him by his father, whose partner he had been, but, dying without a will, the business descended to his wife and two sons, William and Henry, under the superintendence of the elder.

William Caslon III. does not appear to have been very energetic in its management, however, as few new founts were added between the death of his father, in 1778, and his own retirement from the firm in 1793, when he disposed of his share to his mother and his sister-in-law, Mrs. Henry Caslon—his brother having died in 1788. The fortunes of the foundry had by this time sunk to a low ebb, and the efforts of the two women—though both extraordinary ones—were unable to withstand the active competition which was by this time springing up around them. On the death of old Mrs. Caslon, however, Mrs. Henry Caslon bought her share in the

business, and took into partnership Mr. Catherwood. The business tact and energy of the new firm, who at once commenced to cut many new founts of great beauty, soon had their reward, and before the death of the two partners, in 1808, the foundry had completely recovered its fame. Mrs. Caslon's son Henry, and Mr. Catherwood's brother continued the business, and, by great efforts in designing and cutting new founts, kept the foundry up to its new fame. Mr. Henry Caslon's son, who combined the names of Henry and William, succeeded to his father, and, since his death, a few years ago, the business has been carried on under the firm of H. W. Caslon & Co., and, in the hands of its present enterprising managing partner, Mr. T. W. Smith, who has been connected with it for nearly twenty years, it bids fair to sustain the *éclat* of the Chiswell-street foundry. I have described the fortunes of the Caslon family at some length, as it was to its teaching that all the other founders owe their success.

In 1783, William Jackson, an apprentice to William Caslon I., seems to have been diligent in his business, but no steps were taken to teach him the art—then, as now, generally kept secret—of punch-cutting. By cutting a hole in the wainscot, and watching closely, however, he soon obtained an idea how to go to work, and ere long he succeeded in finishing a punch, but on exhibiting it to his masters, with some pardonable pride and expectation of praise, he was astonished to receive a severe blow, and a threat that if ever he attempted such a thing again he would be sent to Bridewell. His mother bought him the necessary tools, and encouraged him to perfect himself in the art at home, remaining still at the foundry to learn all he could. He continued to work for Messrs. Caslon after his indentures were completed, till, during some dispute with the workmen, in which he and a fellow-apprentice, Mr. Cotterill, were thought to be ringleaders, they were discharged. Jackson entered the navy as an

armourer, and by 1763 he had £40 to receive as prize-money. He then, with three others, started a foundry, of which he was the active manager. He carried this on with great success till his death, in 1792, by which time his foundry had become one of the most complete in existence. Amongst other founts that he produced was the one with which Macklin's Bible was commenced, and which was cut specially for this magnificent work, said to be one of the finest ever produced.

About this fount a curious fact is stated. The types were not cast of such hard metal as is now used, and by the time the book of Deuteronomy was reached, Mr. Bensley, who printed it, wished to renew the fount. Mr. Jackson, however, was dead, and as Mr. Bensley did not care to purchase a new fount from his successor, he applied to Mr. Vincent Figgins, who had been an apprentice, and for some years foreman, to Mr. Jackson, to cut him a facsimile of the fount, which he did.

At Mr. Jackson's death his foundry was purchased by William Caslon III., who, we have seen, sold his share in the Chiswell-street foundry to his mother and sister-in-law; he seems to have devoted much more attention to this than to his paternal foundry, for he enriched it with a variety of what are technically called flowers, borders, and ornaments. Mr. Caslon suffered from cataract in both eyes, and, for some years, was totally blind. He was, however, operated on three times, and at last his fortitude was rewarded by the success of the operation, and he was able to see his numerous friends. His son, William Caslon IV., succeeded to his business. He is noted as having invented a method of casting types much larger than was possible up to that time, making matrices, which he called "Sanspareil," without punches. I will explain this later on. In 1819 he disposed of his business to Messrs. Blake, Garnett & Co., of Sheffield, whose suc-

cessors, Messrs. Stephenson, Blake & Co., have found it necessary to open a warehouse in London. In their enterprising hands the reputation gained by Mr. Caslon has been maintained and extended. While they do not neglect book and newspaper founts, this firm, in my opinion, excel all others in the beauty and variety of their ornamental or display types and ornaments.

Mr. Vincent Figgins, whose name I mentioned just now in connection with the cutting of a fount for Macklin's Bible, being unwilling, upon the death of Mr. Jackson, to pay the amount demanded for the purchase of the foundry, of which he had had the sole management for some years previously, was induced by Mr. Nichols, an eminent printer, and others—amongst them the delegates of the Oxford University Press, for whom Mr. Jackson had in hand a fount of Greek at the time of his death, and who suggested that, as Mr. Figgins had had charge of it, he should take the order in hand and execute it himself—to start in business for himself, and, by his skill and untiring industry, he established a large foundry, which is now carried on by his grand-nephew, Mr. James Figgins, Jun., (whose father, the junior member of the old firm of V. & J. Figgins, was recently M.P. for Shrewsbury) in a style well calculated to sustain and to enhance the reputation of the founder.

The only other founders of note in the present day are Messrs. Reed & Fox, of London, and Messrs Miller & Richard, of Edinburgh. Mr. Cotterill, who had worked for William Caslon II., with Mr. Jackson, and who was discharged with him, continued to work with him till the death of the latter, when he commenced a foundry for himself, and produced new founts with great energy. Besides cutting some small sizes, he produced letters of the then unprecedented size of two inches deep—what he would say to see our walls now, when a single letter not unfrequently occupies two sheets

of paper, each 40 by 30 inches, I cannot imagine. At his death, an apprentice of his, Mr. Thorne, carried on the business, which was afterwards purchased by Mr. Thorogood, and then by Mr. Besley, who, coming to London from his birth-place, Exeter, in 1816, when twenty-two years old, was taken into the service of Mr. Thorogood, and afterwards admitted into partnership. On Mr. Thorogood's retirement, Mr. Besley remained at the head of the concern, which was carried on under the style of R. Besley & Co. Subsequently Mr. Fox entered the firm. Mr. Besley, who was Lord Mayor of London in 1869-70, died in December last, in his 83rd year. Some years before his death he disposed of his share in the foundry to Mr. (now Sir) Charles Reed, the eminent chairman of the London School Board, a worthy son of a worthy father, the noble-hearted Dr. Reed. While these pages are going through the press, I see announced the death of Mr. Fox, on the 15th January, 1877.

Of the Edinburgh foundry of Messrs Miller & Richard, it is unnecessary to say more than that, though of comparatively modern origin, it has succeeded in obtaining the patronage of many of the daily newspapers, a fitting reward for the great care displayed in the workmanship of their productions.

Having now run rapidly over the history of the principal existing English foundries, I come to the more technical part of my paper, that of explaining the detail of the manufacture of type.

The first task a founder has is to decide the style of letter he will cut, and in this there is room for the exercise of great taste and judgment, for if the design of the type is not such as commends itself to the eye of the printer, all the founder's work will be thrown away.

The design and size of the type having been decided upon, the punch-cutter is brought into requisition. I may mention

here that punch-cutting is a trade in which there are very few adepts. Nearly every foundry of any note has been established by a punch-cutter; and the late Mr. Vincent Figgins has left on record, that when his father commenced business, one of his principal difficulties was to find the punch-cutter previously employed by Mr. Jackson, his predecessor, for his visits were usually paid to the foundry by stealth, and he was popularly known by the sobriquet of the "black man."



The punch-cutter having been found, he, with patient labour, cuts out each letter on a separate punch of softened steel. Many a time does he take a proof of it by smoking it in a candle, and taking an impression of it on paper, and as frequently does he see, with the aid of a powerful glass, some shade of improvement that may be made, some little corner to be rounded off, or some round to be made sharper, until, at last, it is pronounced correct by his employer, if he be a servant, or passed as the embodiment of his taste, if he be a principal. That this task is not a light one may be judged from the fact that a single punch is often a fair day's work, while on some punches of ornamental letters many days are expended.

There are in a complete fount of roman and italic letters, such, for instance, as our volume of *Proceedings* is printed with, no fewer than three hundred and sixty punches required, and when to the cost of cutting them is added that of the succeeding processes, it will be evident that it is not a small matter for a founder to undertake to get up a new fount of book-letter.

The finished punch is now taken to the hardener, whose duty it is to heat it to the required temperature, and then plunge it in cold water, after which he has to temper it with gentle heat to keep it from cracking when struck—a fate, however, which it does not always escape, for should there be the slightest flaw in the rolling of the steel, its succeeding course of treatment is eminently qualified to develop it. The hardened and tempered punch is now handed to the justifier, who strikes or drives it into a piece of copper of a selected size and thickness, and it is then his task to make this

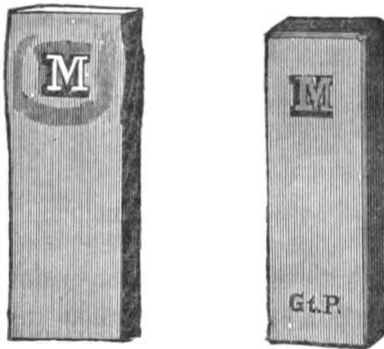

“strike” or “drive” into a finished matrix, and he has to so trim and shape it, that when it is put into the mould to be cast from, the types produced from it shall be even in line, in uprightness, in height, and in width to the types cast from all its fellows, that is, that all the three hundred and sixty matrices shall, upon simply being placed in the mould, produce types which shall look and be regular in every way. As the matrix, in its early stage of a “drive,” is merely struck in hap-hazard, so to say, and as, in the foundry with which I am more intimately acquainted, the instruments used to complete it are such as will measure to the five-thousandth part of an inch, it will be evident that this is no light or unimportant part of the work. The tools used by the firm to which I allude, in this branch of

the business, are exceedingly interesting, but they are of course not such as can be shown here. A tool, for instance, which will enable a man to cut unerringly, say 2° or 3°, as they are called, but which are really $\frac{1}{8}$ or $\frac{1}{16}$ of an inch, from the side of a matrix, is, I take it, a marvel of accurate workmanship.

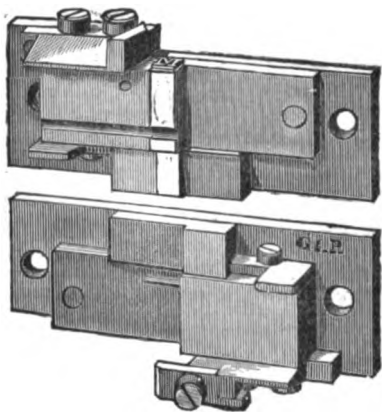

The mould in which, in conjunction with the matrix, the type is cast, next claims our attention. It is made of hardened steel, in two parts, fitting accurately together. For convenience we will examine a "hand" mould, and describe the method of casting by it, though the use of the machine which is its lineal descendant has now almost entirely superseded hand-casting. Each half of it is fixed to a wood cover, to protect the hands of the casters. When the two halves, which are made to fit into each other, and to cast wider or narrower types of the same body,—the width being determined by that of the matrix put into it,—are placed together, the matrix is inserted and kept loosely attached by a piece of string; it is then, by a strong spring, pressed close to the mould, and the latter being held firmly closed in the left hand, a small ladleful of molten metal is taken from the metal-pot, placed at a convenient height over

a furnace, and poured into the mouth of the mould, which is immediately jerked upwards. This motion serves to throw the metal into the matrix, so as to give a firm, solid face to the type. In this it is assisted by what is called the "break," a superfluous piece of metal which is cast in the mouth of the mould, and which, by its weight, helps to fill up the body of the type cleanly and squarely. The whole ladleful often does not contain more metal, however, than would fill a teaspoon belonging to a doll's tea-service. The spring holding the matrix is now loosened, the mould opened, and the type thrown out. This process is repeated as many as six hundred to eight hundred times in an hour, according to the size of the type.

For some letters of larger size, and having very fine lines, however, a different method of casting had to be adopted, the ladle being superseded by a small pump fixed in the metal-pot, to the nozzle of which the mouth of the mould is held, still with the left hand, while the handle of the pump is jerked downward with the right. This forces the metal with considerable strength into the mould and matrix, and gives a better surface, but the metal is not nearly so solid as by ordinary hand-casting. The gentlemen of the pump indulge in what is a necessary to them, though a luxury to most of us—they wear gloves at their work. The pump sometimes forces metal out through the interstices of the moulds, and a supply of left-hand gloves (not of the best French kid) is kept in stock for their benefit.

From this pump-casting has been developed the modern type-casting machine, an illustration of which is given on the following page. In this the opening and closing of the mould, the advancement of it to the nipple of the pump, the jerking of the pump-handle, and the taking off the break, are done automatically. The matrix, as in the hand-mould, is held in its place by the spring, and, on the return of the mould from

the nipple of the pump, it opens and throws down a type, with break already removed, at the rate of perhaps one hundred to one hundred and twenty per minute.

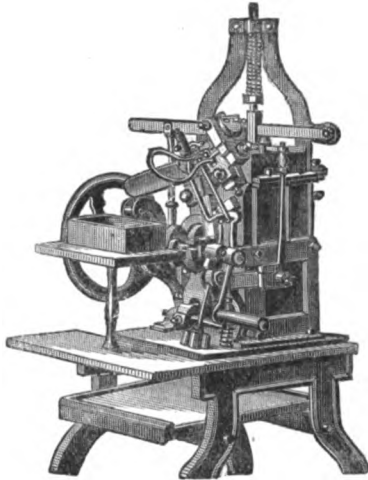

When the type leaves the mould, it is by no means ready for the printer. Carefully and exactly as the moulds are made, they cannot cast the types without a burr or roughness at the edge, and this must be removed, and the foot of the type must be made perfectly square.

The types are first conveyed to the rubbers, who pass them up and down a stone or broad file, and so remove the burr. Some letters, such as the *f*, a portion of which overhangs the body at the top, and the *j*, which is guilty of a similar irregularity at the bottom, have to be subjected to a different treatment, as the ordinary rubbing would remove a portion of the letter; they are therefore carefully rubbed at the edge of a specially-prepared file, or put into a small machine, which cuts out the "kern," as it is called, and leaves the types so that they will not "ride" or rest on each other, and so break off.

I may mention that in many modern newspaper founts the f and j are altered a little in shape, so as to bring the whole of the letter on the body of the type—a little “uneasiness” in the appearance of the letter being preferred to the annoyance of finding the dots of the letters broken off. After rubbing, the types are taken in hand, literally, by the “setters,” another small army of boys, who pick them up and place them side by side in long sticks, with their heads at the top and the nicks in the body of the type outwards. They are then ready for the dressers; these are men of experience and trustworthiness, upon whose care depends a great deal of the credit of the foundry. They first take the stick, nearly a yard long, filled with types, which they handle as if it were solid; they turn them face downward in blocks made for the purpose, and, after locking them up tightly, with a small plane cut a groove in the foot of the types, removing thus the small unevenness left by the removal of the break. A smooth file is then rubbed lightly along to polish the feet, and then they are taken out of the blocks, and the file run over the back and front. A few types are then taken out at each end and the middle of the stick, and these are carefully tested for body, by a dozen of them being placed together against a standard of steel; for height, by careful testing against another standard; for line, &c., by another kind of gauge, and then, if they succeed in passing muster, so far as their bodies are concerned, they are passed on to the picker, who, with a powerful glass in his eye, looks at the face of each letter separately, and throws out with his pick as he passes all which he finds in any way faulty. The types are then made into smaller lines, the lines into pages, and put into stock, and from these pages are made up the founts as required for printers.

So much for ordinary founts; for the large types suitable for posting-bills, a different mode of manufacture is re-

quisite. In consequence of the impossibility of striking a punch of the size required into a matrix, these types were at first cast in sand, but as the roughness of face which they exhibited was an almost fatal defect, William Caslon IV. invented a mode of making matrices, which he called, with justifiable pride, "Sanspareil," a name which still clings to the types cast from them, though I dare say few of the present generation of founders have any idea of the origin of the name. This method consisted in cutting out the shape of the letter desired in plates of brass, the back being cut a little larger than the front, the sloping edge thus formed making the shoulder of the future type; the cut brass is then firmly rivetted to a smooth surface of brass, which forms the face of the letter when cast; the matrix thus formed then undergoes the process of justification. The moulds for these larger sizes are, of course, much larger than the book letter moulds, and, in place of being held in the hand, they are fixed to the wall, and have long handles to manipulate them; they are also provided with cores, to enable the bodies to be cast hollow, in order to lighten the formes when they are set up.

The original matrices made in this way were transferred to the Sheffield foundry in 1819, when Messrs. Blake and Garnett purchased the foundry of William Caslon IV., and for many years the successors of these gentlemen retained a pre-eminence in the manufacture of letters of this size. Of late, however, letters cut in wood have, to a great extent, superseded metal letters, as the latter could never be cast of a size approaching that now common upon our walls. The largest cast types I have seen do not, I think, exceed about five inches deep.

Many efforts have been made to reduce the cost of production of types, by casting, for instance, several letters at once in the style of a comb, of which the types would form

the teeth, but the accuracy which is an absolute necessity in type-founding could not be attained, and the mode I have described is likely to be continued, with but slight improvements, for many years to come. In the model exhibited, for the loan of which I am indebted to Messrs. Caslon & Co., the machine is turned by hand, but throughout the trade now steam is adopted as the motive power, and one man is thus able to superintend two machines.

As an example of accurate justification, I have brought a specimen of French types, prepared for the Exhibition of 1851, and when I mention that of the music, each square inch is composed of about one hundred and fifty types, and that a joining is scarcely to be seen in it, you will agree with me that it is a marvellous piece of work. I also show specimens from the foundry of Messrs. Stephenson, Blake & Co., to whom I am indebted for all the tools, &c., other than the machine, and by permission of our president I am enabled to show a copy of a French founder's specimen-book, which forms one of the treasures of our Free Library. It is only fair to English founders to state that, not only can they compete in accuracy of justification with our French neighbours, but they can far surpass them in the quality of their cast type. One of our English foundries has a branch in Paris, and England is now the centre of the type-founding trade.

ON THE TRANSLATION OF *Συνίημι* AND ITS
FORMS, AND OF ἵνα μὴ WITH A SUBJUNCTIVE
MOOD, IN THE AUTHORISED VERSION OF
THE NEW TESTAMENT.

BY J. BIRKBECK NEVINS, M.D. LOND.

THE words to which I desire to ask your attention are of frequent occurrence in the New Testament, and are there used in a variety of senses, and it is necessary to take the context into consideration before being able to judge with what meaning they are employed in any particular instance. This is generally unaccompanied by difficulty, and in most instances the Authorised Version appears to give their full and true interpretation ; but there are a few cases in which it appears either to fall short of their real significance, or to convey a meaning different from that which I think the Greek text implies, and it is to these cases I invite your consideration.

In the Authorised Version of the New Testament, *Συνίημι* and its derivatives frequently occur, and they are generally, if not always, translated by some form of the verb, "to understand," which generally conveys their true meaning ; but I have to ask your consideration of a proposed change of translation from "understand" to "attend," in a few places, as bringing out the true sense of the word more correctly, and conveying more fully the lesson which it is intended to teach in these places.

This is especially the case in the familiar parable of the Sower, from which I shall quote merely the necessary passages.

In the 13th chapter of St. Matthew, verse 19, we read, "When any one heareth the word and *understandeth*—*συνιέντος*—it not, then cometh the wicked one, and catcheth away that which was sown in his heart;" and in the 23rd verse, "But he that received seed into the good ground is he that heareth the word, and *understandeth*—*συνιάν*—it; which also beareth fruit," &c. The parable in St. Mark, ch. iv., v. 20, is related in different words, both in the Greek and English. The English version, speaking of the good ground, says, "such as hear the word, and receive it, and bring forth fruit;" but the Greek word translated "receive"—*παράδεχονται*—implies more than simply receiving, for the words given in the dictionary as its meanings are, in addition, to "receive," "welcome," "entertain," "embrace," "approve," all implying something of willingness in addition to simple reception.

In St. Luke, ch. viii., v. 15, there is again a difference, the English words being, "that on the good ground are they which, in an honest and good heart, having heard the word, keep it, and bring forth fruit with patience;" but the Greek word *κατέχουσι*, translated "keep," means something more than simple keeping, and "keep fast," or "hold fast," would more truly convey its force. The Greek word *ὑπομονῆ* also loses its real value in this parable when translated "patience," which, in modern English, conveys the idea of more or less suffering or trial; and it would be equally correct, and more in accordance with the evident meaning of the parable, if it were translated "perseverance," or "constancy."

In St. Luke, therefore, as well as in St. Mark, we have the element of will introduced in the parable; but this element appears to be wanting in the parable as narrated by St. Matthew, if the Authorised Version is the correct one, for it appears as if the abundance of the fruit depended upon the "understanding" of the hearer, rather than upon his

will; upon his intellectual powers, rather than his moral character; and it is to this question that we will now turn.

The Greek word translated "understand,"—*Συνίημι*—is a compound, consisting of the preposition *Συν*, "together," and *ίημι*, "I send," and the meanings are--

- To send or put together ;
- Combine or join ;
- Engage ;
- Understand ;
- Attend ;
- Become skilful, act wisely.

The primary meaning of the word is simply sending or putting together, which may be without any definite plan; but the idea of order in a putting together is so natural, that the further meanings, "combine, join," are almost self-evident.

The requisite for making a "combination," as distinguished from a mere "putting together," is *attention* to the matters to be combined, and *understanding* so as to accomplish the junction; and it will probably appear to most minds that the attention is an indispensable requisite before the understanding can be attained; and as the result of combined attention and understanding, we "become skilful," and "act wisely."

Now the bearing of this analysis of the meanings of *Συνίημι* is as follows. If it is translated "attend," then the parable will run—"When any one heareth the word and *attendeth* not, then cometh the wicked one and catcheth away that which was sown in his heart," which is a natural and deserved result of his want of attention. "But he that receiveth seed into the good ground is he that heareth the word and *attendeth* to it, which also beareth fruit," &c., a favourable result of his attention, which is as natural as the unfavourable result from the inattention of the other.

This interpretation of St. Matthew's words harmonises with what seems the natural interpretation of the totally different words used by the other Evangelists, and it represents the result, whether good or bad, as following the moral attitude of the hearer, instead of attributing the barrenness of the one hearer to a want of intellectual acumen, and the fruitfulness of the other to his greater intellectual powers.

The word occurs again in the 15th verse of the 13th chapter of St. Matthew, as a quotation from the Old Testament: "For this people's heart is waxed gross, and their ears are dull of hearing, . . . lest at any time they should hear with their ears, and *understand* with their heart, and should be converted." The word "understand" is again the translation of the Greek word *συνιᾶσι*, but the passage only professes to be a quotation in Greek from a message that was originally given in Hebrew; and as I have unhappily no acquaintance with that language, I hope that we shall have the advantage of hearing from our friend and member, Professor Prag, what is the real force of the word in the original Hebrew. It will be in your recollection that this denunciation was made to the Jews because of their disregard of the law and the commandments given to them by their prophets and teachers; and the meaning of the message which Isaiah was desired to give seems to be, that he was to threaten them with what is sometimes called judicial blindness or deafness, because they would not attend to the light or the instructions given them. On turning to the Septuagint, to see whether it throws any light upon the subject, we find that that book employs merely another form of the same word which is quoted by St. Matthew, namely, *συνῆτε*, "hearing, hear, and do not *understand*," so that we do not derive any help from that; but the Vulgate translation of this passage in the Septuagint is remarkable, and seems to point in the direction indicated in this Paper, for it

reads thus:—Isaiah, ch. vi., v. 9. “Et dixit, vade et dices populo huic audite audientes, et *nolite* intelligere;” hearing, hear, and be *unwilling* to understand. The element of will, or of moral attitude, is brought out prominently in this passage in the Vulgate, whilst it is left undetermined by the Greek, and is entirely omitted in the Authorised English Version of this word, *Συνίημι*.

A totally different quotation, containing, however, the same word, is met with in the 3rd chapter of the Epistle to the Romans, at the 10th and 11th verses:—“*Καθὼς γέγραπται ὅτι οὐκ ἔστι δίκαιος οὐδε ἓς: οὐκ ἔστιν ὁ συνιῶν, οὐκ ἔστιν ὁ ἐκζητῶν τὸν θεόν;*” which is translated in the Authorised Version: “There is none that doeth good,” here is the moral element; “there is none that *understandeth*,” which describes merely intellectual deficiency; “there is none that *seeketh* after God,” where, again, we have the will and the moral element introduced. So that, as the passage stands in the Authorised Version, there is, first and last a denunciation of moral guilt or moral negligence, and between these two charges blame appears to be imputed for intellectual deficiency. But if *συνιῶν* is translated “*attendeth*,” then the passage will run—“there is none that *doeth* good, there is none that *attendeth* (to the words of instruction), there is none that *seeketh* after God.” In each case it is the moral attitude that is the subject of blame; and the proposed change of translation appears to render the quotation harmonious throughout, and consistent with what might be expected from the Searcher of Hearts, while, as it stands at present, there is an inconsistency between its various portions, and blame appears to be imputed for what can scarcely be regarded as a fault, viz., intellectual incapacity.

In the discussion, Rabbi Prag, Professor of Hebrew in

Queen's College, Liverpool, and Rabbi of the Synagogue in Prince's Road, Liverpool, said—

“The Hebrew equivalents for the word ‘understand,’ which occurs in the 9th and 10th verses of the 6th chapter of Isaiah, and which in the Septuagint is rendered *συνῆτε*, are *יִבְיִי* and *יִבֵּן*. The former is in the third person plural of the future tense, ‘They shall understand,’ and the latter in the third person singular, ‘He shall understand.’ The radix of this verb is *יָבַן* or *יָבֵן*, denoting ‘to attend perseveringly, to distinguish, to understand,’ and is apparently connected with the root *בָּנָה*, ‘to build, to form,’ both verbs being defective and of similar consonants, viz., *בֵּן*. From this it may be inferred that the original meaning of *יָבֵן*, ‘to understand,’ is *to construct, to form thoughts and ideas systematically, so as to gain a clear comprehension of the subject required.* *בְּנֵי*, sons, from *בָּנָה*, ‘to build,’ denotes, in Jeremiah xlix. 7, ‘the wise.’

“The passage in question, as rendered in the Authorised Version of the Bible, seems utterly incomprehensible.

“‘Make the heart of this people,’ &c. Is it likely that the Divine Creator will have commanded his prophet to close the heart and the eyes of any of his human creatures against the beauties and propriety of his instructions, and to prevent them from becoming repentant and being healed?

“The correct translation of the two verses is the following:—

“v. 9. And He said, Go, and tell this people, they hear incessantly, but do not [care to] understand; they see continually, but do not [care to] perceive.

“v. 10. [This] will render the heart of this people fat, make their ears heavy and their eyes blind, that they shall not* be able to see with their

* Authorised Version: *lest*, the Hebrew term is *לֹא*, and denotes, wherever it occurs in the Bible, “that not.”

eyes, to hear with their ears, and understand with their hearts, and repent and be healed."

The Rev. George Butler, Principal of the Liverpool College, writes:—

"(1) *συνήμι* (I send along with) is never used in the New Testament in its original meaning.

"(2) In the sense of 'animadverto'—'I give my attention'—it is frequently used. But it means something more than this. It commonly means at least as much as our own word 'understand,' *Lat.* 'intelligere': sometimes it may be rendered, 'lay to heart,' *Lat.* 'in animo recondere.' However, all these may be classed under one head.

"(3) In one passage, Rom. iii. 11, it seems to mean, 'Deum colere,' worship God.

"All the passages that I know of referable to the second head are—

Matt. xiii. 13, 14, 15, 19, 51; xv. 10; xvi. 12; xvii. 13.

Mark vii. 14; viii. 17.

Luke ii. 50; viii. 10; xviii. 34; xxiv. 45.

Acts vii. 25; xxviii. 26, 27.

Rom. xv. 21.

2 Cor. x. 12.

Eph. v. 17."

From the discussion, therefore, it would appear that the primary meaning of the Hebrew is "to attend perseveringly," which contains the element of will; and understanding is the result; and that the root "to build, to construct," also conveys the idea of attention, before the result is attained of "gaining a clear comprehension of the subject," in other words, "understanding:" and the Hebrew also bears out the suggestion now put forward, that "attend" should be substituted for "understand," in the passages under consideration in the Authorised Version of the Bible.

ἵνα μὴ, with a Subjunctive Mood.

This form of expression occurs in an important passage in the Epistle to the Galatians, ch. v., v. 17, of which I now ask your consideration, as the manner in which it is translated in the Authorised Version appears to me to be, not simply defective, by failing to give it full force, but incorrect, by conveying a meaning almost the opposite of what St. Paul really intends to express. In any inquiry, however, into the meaning of a Greek expression in the New Testament, the first requisite is to examine the way in which it is used by the New Testament writers themselves, as Hellenistic Greek by no means corresponds in meaning at all times with Classical Greek; and I therefore commenced the investigation into its meaning in the present case by examining every instance in which ἵνα with a subjunctive, and either with or without the negative μὴ, occurs in the New Testament. The instances amount to hundreds, and the value of the expression is exceedingly different in different places, so that each case has to be considered upon its own merits, and to be decided chiefly, if not entirely, by the context.

The phrase under consideration occurs in the 17th verse of the 5th chapter of the Epistle to the Galatians, as follows: "For the flesh lusteth (longs for, or wishes for) against the Spirit, and the Spirit against the flesh; and these are contrary the one to the other: ἵνα μὴ, ἂν θέλητε, ταῦτα ποιῆτε," which is translated in the Authorised Version, "so that ye cannot do the things that ye would."

Now, the first point to be noticed, in examining this passage, is, that the word "can," "cannot," in the English, is an auxiliary which has no place in the Greek, in which we have merely the subjunctive mood, commonly said in our grammars to mean "may," or "can." In this instance the auxiliary "can" was adopted by the translators of the Autho-

rised Version, and the object in view in this Paper is to show that "may" would more truly represent the meaning of the passage, and that, when thus translated, the interpretation will correspond more nearly than at present with the facts of our nature, as compounded of flesh and spirit. After having pursued the investigation for some time, I gave it up, from finding that in Dean Alford's version of the New Testament the verse was given, "so that ye may not do the things that ye would," instead of "so that ye cannot." No explanation is given of the reason for the change, nor any allusion to the important difference of meaning implied in the different rendering; but as the change had been made, I thought it had become a settled matter that "may" was right, and "can" was a mistake, until I observed, a few weeks since, in a version of the New Testament recently published, and professing to exhibit the most recent knowledge of the text, &c., that the Authorised Version was still followed in this case. I therefore hope for your indulgence in having brought the subject forward, if the question should, after all, be shown in the discussion to be a settled one among biblical linguists.

The word ἵνα is translated in the dictionary "that," "so that," "to the end that," "if," "if so;"

ἵνα μὴ , "that not," "lest," "lest that;"

ἵνα τι , "to what end or purpose," "wherefore," "why." In every case, whether alone or in combination, *purpose* is implied by the word; and if we substitute "in order that," or "to the end that," for "so that," in translating the verse under consideration, we shall see at once that "in order that ye cannot do the things that ye would," is an unmeaning expression; while "in order that ye *may* not do the things" is a perfectly intelligible and rational sentence.

It is to be noticed, also, that when St. Paul wishes to express "cannot" without any uncertainty as to his meaning, he does not employ the subjunctive mood, but says

plainly, "are not able." In the 10th chapter of the First Epistle to the Corinthians, v. 21, he says, "Οὐ δύνασθε ποτήριον πίνειν, ὅτι δύνασθε τραπέζης μετέχειν, "Ye are not able to drink the cup; ye are not able to partake of the table;" which is translated in the Authorised Version simply as "ye cannot."

Two questions, therefore, arise. First, Does ἵνα always imply purpose when used by the New Testament writers? and, Second, Can any rational and intelligible explanation be given of St. Paul's object in telling the Galatians that the Spirit and the flesh were opposed to and strove with each other, for the express purpose of preventing us from doing what we would?

Now, the answer to the first question is, that ἵνα is used repeatedly in the New Testament without implying any purpose. It is employed as a substitute for ὥστε, or ἔτι, and in other ways that have no reference to purpose or intention. A few examples of this may suffice.

- Matt. vii. 12. "All things therefore that ye would that men should do to you."
 „ viii. 8. "I am not worthy that thou shouldst enter under my roof."
 „ x. 25. "It is enough for the disciple that he be as his master."
 „ xii. 16. "And he charged them strictly that they should not make him known."
 „ xiv. 36. "And besought him that they might but touch the hem of his garment."
 Mark iii. 9. "And he spake to his disciples, that a small ship should wait on him."
 In this instance, "in order that" would be clearly a mistranslation; but in the very same verse, ἵνα is

used, implying purpose, "in order that the crowd might not press him."

- Mark ,, 12. "And he straitly charged them that they should not make him known."
- ,, v. 10. "And he besought him much that he would not send them out of the country."
- ,, vi. 8. "And he commanded them that they should take nothing for their journey."
- Luke iv. 8. "Command this stone that it be made bread."
- ,, viii. 32. "And they besought him that he would suffer them to enter into them."
- ,, ix. 40. "And I besought thy disciples to cast him out."
- ,, ix. 49. "But they understood not this saying, and it was hid from them, that they perceived it not; and they feared to ask him."
- ,, xvii. 2. "Better for him. . . than that he should offend one of these little ones."
- John iv. 34. "My meat is to do the will of him that sent me."
- ,, vi. 29. "This is the work of God, that ye believe on him whom he hath sent."
- ,, vi. 39. "This is the will of the Father that sent me, that of all which he hath given me I should lose nothing."
- These may suffice for illustrations from other writers, and

if we examine the mode in which St. Paul himself uses the words we are considering, we find that he also employs them sometimes, but not frequently, without implying "purpose," *e.g.* :—

- 1st Ep. Cor. i. 10. "Now I beseech you, brethren, that ye all speak the same thing."
 „ i. 17. "Not with wisdom of words, lest the cross of Christ should be made of none effect."
 „ iv. 2. "Moreover it is required in stewards, that a man be found faithful."
 „ vii. 29. "It remaineth, that both they that have wives be as though they had none."
 „ ix. 15. "It were better for me to die, than that any one should make my glorying void."

He uses it in the Epistle to the Ephesians, both as implying purpose and without any reference to purpose, in the same chapter—the 5th—when describing the duties of married life :—

- Ep. to the Eph. v. 25. "As Christ also loved the church, and gave himself for it; that he might "
 (implying purpose).
 „ v. 33. "Let the wife see that she reverence her husband " (not implying purpose).

It is, however, I think, beyond doubt that the expression under consideration is generally used to imply purpose by the New Testament writers, whether it is employed alone or in combination with the negative μὴ. ἵνα πληρωθῆ—“that it might be fulfilled”—is an expression of such constant occurrence, that it only requires to be alluded to to be recognised. And when every instance is examined in which the combination

of *ἵνα* with a subjunctive occurs in the New Testament—and they are very numerous—it appears to me impossible to doubt that purpose is implied in the verse under consideration, and that “in order that ye *may* not do the things that ye would” is the only rendering that is capable of conveying its meaning. We come, therefore, to the consideration of—Why should the flesh and the spirit strive against one another, in order to prevent us doing what we would? And I think that we meet with the answer in one of those paradoxical sayings of Solomon, which sometimes puzzle and at others delight us. In the 7th chapter of Ecclesiastes, at the 16th verse, he says, “Be not righteous over much, neither make thyself over wise: why shouldst thou destroy thyself. Be not over much wicked: why shouldst thou die before thy time.” Solomon here appears to indicate two opposite lines of thought and conduct, which met in their greatest contrast in the school of the Hermits as represented by S. Simon Stylites on the one hand, and in the utterly debased condition of society on the other, previous to the destruction of the Roman Empire. These two schools have probably always existed in varying degrees; and, in a modified form, they may be described as the ascetic on the one side, and the Epicurean or sensual on the other. Now, whoever would influence mankind at large, must bear in mind the two-fold nature of which it consists; and Solomon’s caution, “Be not righteous over much; why shouldst thou destroy thyself,” is but another mode of saying, Do not forget that the body has its requirements as well as the spirit, and if this is overlooked, you will destroy yourself when trying to be wise above measure. And, on the other hand, do not give the reins to your mere bodily appetites, for that will but cause you to “die before your time.” The same teaching precisely is contained in St. Paul’s remarks, that the spirit strives against the flesh, *in order that man may not be sunk in*

sensuality and become a mere beast, while the flesh also strives against the spirit, *in order that* we may not be misled into thinking that we are angels before our time and despise our bodies, but that we may, by proper care of them, be enabled to fulfil our several duties in life, of which one of the first, and not the least attended with accompanying blessings, is, that men must work. But if work is a primary object of man's existence, it is of the last importance, looking at human nature as it is, that his work should be done with a good courage and with all his heart; and if we are prepared to admit that it is a sound philosophy which recognises the benefit of the contest carried on between our two natures, I think we shall be ready also to admit that the teaching which boldly puts this forward and shows its beneficial character is better calculated to give a good courage and to help the man forward in his daily work, than a teaching which should represent to him that he is powerless to resist evil, and cannot do the good things that he would.

Now, we know that schools of thought have existed, as a matter of fact, which have been based upon the belief that the flesh is so triumphant in this contest that it is impossible to do good; and if we feel that success is impossible, the result soon occurs that effort slackens, even if it does not entirely cease. But if there is good reason for believing that the contest is on purpose that we may not do the *evil* that we would, it is then waged with a braver spirit and a brighter hope, and not only is Excelsior carried on our banner, but we may fairly trust that Excelsissimum will be our home.

On these grounds, then, I submit the altered translation to your criticism.

- 1st. That it is the correct one.
- 2nd. That it is in perfect accordance with the facts of our nature, and
- 3rd. That it contains a much more ennobling and

elevating teaching, and is better calculated to make man a victor, than that which represents him as vanquished from the very commencement of the strife in which he is engaged through life.

The Rev. G. Butler said, in a written communication, "The true sense of *ἵνα μή* is 'telic,' *i.e.*, signifying purpose, 'that, not,' *e.g.*, 1 Cor. iv. 6, *ἵνα μή φυσιοῦσθε*, 'that ye be not puffed up.' Some think this is the present indicative; I regard it as an Alexandrine form of the subjunctive. In Homer *ἵνα* is also used with an apparent indicative, *ἴν' ἕϊδομεν ἀμφω*, which really is, *ἕϊδωμεν*, shortened. Alford insists that this is the only meaning the particles can have. I do not agree with him, *e.g.* John xix. 31, *ἵνα μη μείνη*, 'ne manerent,' lest they should remain. They seem to me occasionally to mark a result, as *ὥστε* is used; Luke ix. 45, *ἵνα μή ἄισθωνται*, 'ita ut non intelligerent,' so that they did not understand, when *ὥστε μή ἄισθυσθαι αὐτοῦ* would be the more usual Greek.

"Luke viii. 10, *ἵνα βλέποντες μή βλέπωσι και ἀκούοντες μή συνιῶσιν*, so that although seeing (outwardly) they do not see (inwardly), and although hearing they do not lay to heart (or understand).

"The interpretation of this passage is of great importance, for the question of human responsibility depends upon it.

"I refuse to accept an interpretation which would make an Omnipotent Being *first* the author of His creatures' ignorance, and *then* their punisher on account of that ignorance.

"I also refuse to interpret John xix. 36, *ἵνα ἡ γραφή πληρωθῇ*, 'in order that the Scripture might be fulfilled.' I think it is equivalent to *ὥστε πληρωθῆναι τὴν γραφήν*. 'So that the Scripture was, *ipso facto*, fulfilled.' Although Alford and others have some reason on their side when they say, The 'Author of Revelation and inspirer of ancient prophecy in the Old Testament, is the same as the Author of

man's Redemption in the New Testament, and He may as well control human actions to justify His word, as utter beforehand words which hereafter will be exemplified in action.'

"There are other passages where ἵνα μὴ is used in the 'telic,' *i.e.*, the proper sense, *viz.*, in 2 Cor. ii. it occurs three times. Cor. vi. 3; and it may be used very many times.

"We must remember that the word ἵνα does not always mean 'that.' It is sometimes an adverb, and means 'where,' as in Sophocles—*ὄυχ ὁρᾷς ἰν' εἰ κακῶν*, 'See you not in what misfortune you are (lit. where, in regard of).' As, therefore, the particle ἵνα has no 'telic' force in certain expressions, there is no reason why, in combination with μὴ, it should have it invariably.

"Again, Alexandrine Greek (commonly called Hellenistic) is by no means so accurate as Attic Greek. And I should not scruple to reject an interpretation, even if the ordinary usages of the Greek language were in favour of it, if it appeared to me derogatory to our conceptions of God's justice and man's free will.

"I believe that Jesus Christ offered salvation to all. I do not believe that he used dark riddles to blind men's eyes. He did not teach in parables till the Jewish authorities had ascribed His miracles to Beelzebub; and He had an object in avoiding collision with the Jewish authorities—namely, that He had a spiritual kingdom to found, ministers to train, doctrines to disseminate, and the example of a blameless life to set, before He resigned himself to the Jews, who sought to kill Him.

"Till that time His invitation was, 'He that hath ears to hear let him hear.'

"No amount of argument, based on Greek particles, will convince me that He purposely blinded men's eyes, and closed their ears, to the truth."

In reference to the question as to whether ἵνα ἡ γραφή πληρωθῆ should be interpreted "in order that the Scripture might be fulfilled," or "so that the Scripture was (*ipso facto*) fulfilled," as proposed by Mr. Butler, the expression in St. John xix. 28 appears deserving of notice, as illustrating the sense in which it was meant by that Evangelist; for he writes about an unfulfilled Scripture, and says, "in order that it might be fulfilled" or "completed" Jesus said, "I thirst." ἵνα τελειωθῆ ἡ γραφή, λέγει Διψῶ—and as a result some one ran with a sponge and vinegar, and Jesus tasted it, and then said, "It is completed," τετέλεσται, which would appear to indicate that the expression ἵνα πληρωθῆ refers to a purpose to be completed, rather than to a fact which has been accomplished.

St. Matthew, also, who uses the expression more frequently than any other Evangelist, appears to shew that he does not use it in the past tense, for he does not employ it at all in one important passage, where he is speaking without any doubt about an accomplished prophecy, viz., the slaughter of the children in Bethlehem. He there says, Matt. ii. 17, τότε ἐπληρώθη το ρήθην then *was* fulfilled, although, in the same chapter, at the 15th verse, he has employed his familiar expression about the prophetic reason for the flight into Egypt, ἵνα πληρωθῆ, that it might be fulfilled, "out of Egypt have I called my Son."

But at the time referred to Jesus had not returned out of Egypt, and therefore he was not yet called out of Egypt, and the prophecy was not in fact accomplished at the date of which he is speaking.

THE AUTOBIOGRAPHY AND MEMORIALS OF
MISS HARRIET MARTINEAU.

By EDWARD R. RUSSELL.

The book of 1877 has the following title:—“*Harriet Martineau's Autobiography, with Memorials by Maria Weston Chapman.*” The title-page bears two mottoes:—“*Etiam capillus unus habet umbram suam,*” a proverb, and these words from Lord Bacon:—“And this dear freedom hath begotten me this peace, that I mourn not that end which must be, nor spend one wish to have one minute added to the uncertain date of my years.” Owing to the peculiar manner in which the book has been produced, it is not apparent whether these mottoes were chosen by the writer of the Autobiography or the compiler of the Memorials—a point which, in her zeal and devotion, Mrs. Chapman may not have thought of much importance, but the doubtfulness of which is fretting in its effect upon those who at a greater distance have honoured Miss Martineau as profoundly as the Editor herself. This is not the only instance in which the book tempts one to wish Miss Martineau's friends a little farther from her side.

It is in three volumes, and has two imprints. One, attached to the first volume and the second, preserves the memory of one of Miss Martineau's characteristic, if not eccentric, fancies. She completed the Autobiography in 1855, when she was fifty-three years old, and stricken with a disease which she expected to bring her life to a speedy end. Veteran author as she was, and in daily communication with London, she preferred to have her life printed, with due precautions for secrecy, at Ambleside, and there the sheets

have lain for twenty-two years, until brought out and bound up in two out of the three volumes of this work, which will reveal the personality of Harriet Martineau in sharp, if not bold, relief to future generations.

For the third volume, the Editor, Mrs. Chapman, is solely responsible, and if she possesses any of her beloved friend's sensitiveness, she must by this time have fully felt her responsibility. She has been laughed at for her heroics—her "north wind," and her "rose leaves," and her grand concluding extract about those from whom Persephone accepteth atonement for an ancient woe. She has been quizzed for her English—strange to say, a weak point in more than one of Harriet Martineau's idols. She has been blamed for publishing letters which Miss Martineau would have suppressed, and for aggravating a flavour of family bitterness, which in the Autobiography is comparatively faint. I shall not echo or support these censures. As to the lady's English and her raptures, it is enough to say she is an American philanthropist. On the more serious questions we must remember that no precise rules of taste or propriety, or even utility, can be laid down on the subject of biography. How much or how little should be told, and why, or why not, are points on which there are as many opinions as readers. Each notable book of this kind must stand or fall by its fortunes, rather than by its merits, according to any invariable standard of criticism. Mrs. Chapman appears to have received from Miss Martineau ample powers, and everything in the book suggests that her friend would have seen no fault in anything she did.

They first met in America, in 1834, when Miss Martineau bravely travelled through the excited States with Abolitionist colours flying. Mrs. Chapman was one of the little band of like-minded Americans who were pioneering for the emancipation, which, like many other good things, was to be

brought about eventually only by war. One day she came and told Miss Martineau they were threatened by a mob. "I hear now," says Miss Martineau, writing twenty years after, "the dear silvery tones of her who was to be the friend of the rest of my life. I still see the exquisite beauty which took me by surprise that day; the slender graceful form—the golden hair which might have covered her to her feet—the brilliant complexion, noble profile, and light blue eyes—the aspect, meant by nature to be soft and winning only, but that day (as ever since) so vivified by courage, and so strengthened by upright conviction, as to appear the very embodiment of heroism." When this warm worshipper, whom the English world little suspected of such a fund of idolatry—Mr. Atkinson not having then risen above the horizon—returned to her home and avocations, she found that "her relation to Mrs. Chapman required her greatest moral care." "The discovery of her moral power and insight," says Miss Martineau, at the date of the Autobiography, "was to me so extraordinary, that, while I longed to work with and under her, I felt it must be morally perilous to lean on any one mind as I could not but lean on hers. Thus far, whenever we had differed (and that had not seldom happened) I had found her right; and so deeply and broadly right as to make me long to commit myself to her guidance." Hence the celebrated Harriet Martineau found it necessary to avoid being constantly with the unknown Maria Chapman, because "such a committal" of oneself to another "can never be otherwise than wrong." To some, such self-abnegation in a woman of such intellectual strength may seem unnatural. I shall presently say why I think it entirely consisted with the type of Miss Martineau's power. At all events, it and the whole subsequent course of her judgment of Mrs. Chapman warrants us in supposing that she would not have vetoed anything Mrs. Chapman chose to publish about her. So

long as readers can distinguish what Miss Martineau herself left for publicity, no harm is done, although some of the things published may be painful to her connections. A family which produces one of the greatest men and one of the greatest women of a century must submit to the penalties of a grandeur brighter even than that which illuminates the least and obscurest incidents of palaces. Privacy it must virtually forfeit. Nor need the world go mourning over the feelings of a sister who could express in print her disappointment, forsooth, with such a brother as James Martineau, or of a brother who could scathe such a sister as Harriet Martineau in the pages of a review. If there are grounds of serious complaint, it is not on behalf of the family, who must take their chance, nor on behalf of public men, whose distinction makes them virtually the property of the world, but on behalf of several persons of private station, whose accidental associations with Harriet Martineau have led to their being mentioned here a great deal more freely than to quiet, retiring people is agreeable.

The three volumes, as they stand, are a very complete exhibition of Miss Martineau's character, and so far as she prepared the book it is a tribute to the value of Autobiography. When she had once begun her narrative, the completion of it became a necessity, not for the mere pleasure, nor because she had in any considerable degree to justify herself, but because, as she wrote, the convictions deepened which she expressed in the beginning, that from the most meagre to the fullest all autobiographies were of great profit, and that she, from the strength of her memory, was especially fitted to write a useful one. Yet it may be doubted whether utility is the strong point of her reminiscences, and we may with confidence deny that such utility as it has lies in the elements of her recital to which the biographer attached most importance.

Persons deeply interested in literature are often tempted to doubt the value and propriety of lives and memories, which, in revealing the characters of authors, do not sustain those conceptions of their personality which have been formed from their works. Such is the case of Heine, for instance, and perhaps of Dickens. It would be a bold innovation, however, to discourage the exhibition of what at the very least must be curious and instructive mental and moral studies; and the thing to be insisted on is not that great writers should be kept artificially on the level of their books, but that we should judge their writings and themselves justly apart, except so far as it may be useful to fix the mind occasionally on the fact that men and women capable of such and such weaknesses have produced such and such great works. The mind, even of an average reader, may be easily drilled into appreciating a great work in spite of its author's littlenesses.

The literary character has many defects, some seated in its essential temperament and constitution, some the accretions of usage, nearly all susceptible of correction; and to their correction the publishing of literary lives must surely tend. Miss Martineau had only one of the acknowledged foibles of literary persons—a certain fretful irritability, lying in wait not only for criticism, but for all sorts of small maltreatment by Society. In her, however, this was corrected by a good opinion of herself, too well-founded and too far removed from vanity to permit of her becoming ridiculous. As a writer, therefore, she will not suffer in estimation from the publication of this Autobiography, as authors often do from revelations, however prudent, of their actual daily lives. All is not said yet, however, on this question of the utility of her memoirs.

Whatever may have been the case with the other Martineaus, Harriet and her brother James were by congenital temperament Methodists—or, in deference to their

ancestry, shall I say Huguenots? remembering that a great French critic has said that Geneva has always been a vestibule of Proselytism for that Christian awakening for which Methodism is another name. *He* was a Pietist who found peace in the soothing beliefs and devout practice of Unitarianism. *She* was a Pietist who could not find peace until she altogether gave up seeking it in theology. The usefulness of the story of her life, as she saw it, lay in telling first of the early home treatment out of which she supposed the habit of mind which I call Methodism grew; secondly, of her partial manumission by the adoption of the doctrine of necessity; and thirdly, of her total emancipation by the adoption of Atheistic Materialism. Here she was mistaken. The book has no utility, no philosophical merit or importance, in this aspect, except as a morbid study, whose only interest lies in the fact of so clear and fine a mind having become the prey of empty sophisms and an emptier sophist.

Harriet Martineau was a fretful, irritable, haunted, "injured" child, as many a one has been in whom the literary faculty was really the absorbing substance of being and character. Such children are seldom understood. Anyone who, having been such a child, has had parents who did not rudely crush or abrade his or her nature day by day with rude though unconscious cruelty, has a great boon to be thankful for; and what is bad always was certain to be very bad in a prim Unitarian household in a provincial city at the most rigid period of English family manners. The morbid young girl sought relief in intense religiousness, and found some in the happy accident of receiving from an excellent master a masculine education. Deafness came, and brought upon her new unkindness, or what she looked upon as such, from her family. Her life thenceforward, till her father's commercial anxieties and death broke up the home, appears to have been a curious mixture of wounded susceptibilities,

fairly encouraged intellectual activity, peculiar whims of shyness and mystery, substantial domestic happiness, and incessant but perpetually balked yearnings for effusive filial relations. In all this, in after years, Miss Martineau and Mrs. Chapman appear to have read a history of coarse and blind ill-treatment, whereas it was only the natural routine of a placid but solid and self-respecting English middle-class family, disturbed and fretted by the peculiarities and dogmatisms of a clever, singular, and not too agreeable daughter. The whole course of average domesticity and education is not to be assigned as criminal, because, under such circumstances, such a daughter does not carry into her future life very agreeable recollections of her youth.

When Miss Martineau had made her mark, and become a great personage, when she found herself within a few months of her first signed publication a lion of London—and when lords and *litterateurs*, Cabinet Ministers and quarterly reviewers came crowding around the “little deaf woman from Norwich,” who, Lord Brougham said, had beaten them all—she should have forgotten all about her Norwich vexations, her fancies, and her fumings, her early abandonment to solitary woe, and the rarely yielding coldness of a mother against whom, after all, she could bring no tangible accusation; and she should never have recurred to these things. It would save a great deal of trouble, indeed, if all persons who have public positions and public successes were philosophically to dismiss from their minds all thoughts of getting, or of ever having got, any comfort out of their relations. If they did so, whenever any such family comfort or appreciation came, it would be so much to the good, and their enjoyment would be in inverse ratio to the smallness of their expectations. I say this even on the supposition that Miss Martineau’s and Mrs. Chapman’s depreciatory insinuations as to Mrs. Martineau were in some degree just. If, as one hears it

whispered, these innuendoes of unmotherly conduct are groundless, it is so much the more to be regretted that the great authoress was not silent on and superior to all family grievances.

Miss Martineau had not this wisdom. Even in so small a matter as going to Westminster Abbey to see the Coronation, she cannot help laying it upon a brother, nearly twenty years after, that she was late, and got a bad place, and was very poorly after the ceremony. If, by way of contrast, we glance at so serious a question as love and marriage, we find indeed that here her experience was really tragical, for her quiet, uncomplaining lover suffered himself to be estranged from her, became insane, and died; but one does not like to read that it was all because "his family had been given to understand by cautious insinuations that she was engaged to another." Nothing could be in better taste or feeling than Miss Martineau's references to this unfortunate gentleman; but the cause of their severance might surely have been removed by a little frankness, and at any rate her way of regarding the affair in after years was extremely morbid.

The young man had absented himself when he thought she was rich. Like a gentleman, he reappeared when he knew she was poor. She "was at first very anxious and unhappy." Her "veneration for his *morale* was such that she felt she dared not undertake the charge of his happiness; and yet she dared not refuse, because she saw it would be his death-blow." How loftily she would have censured such a frame of mind in another! "Many a time did I wish," says she, "that I had never seen him. I am far from wishing that now—now that the beauty of his goodness remains to me, clear of all painful regrets. But there was a fearful period to pass through." What one regrets is that Miss Martineau did not really get through it. True to the characteristics of her temperament, she suffered this incident

to colour her views of marriage. Such natures dwell on every incident of their own lives as if the whole universe were occupied with them, and as if at every turn of their fortunes Providence were demonstrating for the eternal instruction of mankind some new and perplexing moral therefrom, whereas, in fact, there is an average of these things—an average of disappointed lovers, of libelled lady-loves, of spoiled marriages—an average even of Harriet Martineaus in their private and inferior aspects, though there is by no means an average of Harriet Martineaus in their public work, the number of them being too few and their distinction too grand and individual.

All through this book one is haunted by a conspicuous disparity between the greatness and excellence of a noble woman's work and the fretful fussiness of a weak woman's fancies. Those who regard the failings of each sex as ineradicable will see nothing in this to evoke lamentation. They will say "She was a woman: what else than such fancies do you expect?" My reply would be, Did you expect of a woman the History of the Peace, or the Biographical Sketches, or the six splendid leading articles a week which for many years Miss Martineau wrote for the *Daily News* in its great days, or even the stories of political economy which she produced at thirty, getting her facts and principles from hand to mouth with the tact of a true publicist, but also with the true judgment of a publicist, always avoiding mistakes, and compelling the respect and admiration of the foremost statesmen of her stirring time? If you had all these fine and masculine achievements from a woman, and from a woman who had had no advantages except those of nature's gift, and the happy accident of having pursued boys' studies under the instruction of a man, was it too much to expect in addition a manly reticence and private philosophy in proportion to the strength positively without febleness, and the judgment

practically without flaws, which distinguished her professional and public character? That it *was* too much is evident from the fact that to pass from Miss Martineau's works to Miss Martineau's Autobiography is like quitting a conversation with Socrates to go and take afternoon tea with Xanthippe. But that it *ought not* to have been too much will be a cherished opinion of all who hold, as I do, that intellectual foibles are amenable to intellectual discipline—that moral deficiencies of sex, like moral deficiencies of constitution or race, are only demands for the exercise of self-control and self-modification—and that a woman who has got rid of the customary mental sterility of her sex ought to make short work of its frailties of mood and temper.

For my own part, I cannot help feeling that this Autobiography would have been very different in its treatment of the facts of her early life, if, instead of making the acquaintance of Mr. Atkinson, the mesmerist and prophet, she had come under the influence of a true philosopher, or even of a sensible man. It may be very fine to send people to sleep by passes and to lull their pain by your "dynamic glance," to get rid of the mystery and difficulty of free-will by pretending to fancy humanity an automaton, and to persuade your friends that though the Christian miracles are unbelievable your *clairvoyantes* can see what is going on a thousand miles off, and you yourself can foretell the future. A few words of healthy admonition to a woman such as Harriet Martineau, telling her to be as manly in herself as she was in her books, would have been better worth uttering than all the counterfeit science of Mr. Atkinson by which she was so unworthily enthralled.

I have spoken of the unfortunate tone of Miss Martineau's comments on her frustrated marriage, and, unless you think the subject too sentimental, I will be more particular on this head, because it happens that no more striking instance can

be afforded of the contrast between her writing about herself and what she wrote as an author. In her Autobiography she neither treats the subject like a philosopher nor lets it alone like a philosopher. First, she is careful to tell the world, as all mature spinsters tell their friends, that if she never had anything to do with love and marriage, it was not for want of importunity, of which, she says, every literary woman has plenty, "but freedom of mind and coolness of manner dispose of it very easily." She "can easily conceive," indeed, "how some deep springs of her nature might have been touched then as earlier," but she "considers the immunity a great blessing under the liabilities of such a moral condition as hers was in the olden time." "If she had had a husband dependent on her for his happiness, the responsibility would have made her wretched. She had not faith in herself"—so she thinks, this vigorous, firm lady who battled with all the world in London, and held her own against publishers and politicians, flatterers and calumniators—"to endure avoidable responsibility. If her husband had not depended on her for his happiness, she would have been jealous. So also with children." The care would have overpowered the joy; the love would have been out of proportion to the chances of life; her fears would have impaired their freedom. Domestic life "is not for those whose self-respect has been early broken down, or has never grown." When she sees perfect conjugal love she shudders at its profundities. Among little children she is frightened to think what her idolatry of her own would have been. Her strong will, combined with anxiety of conscience—and this long after her supposed Atkinson emancipation from all sources of moral uneasiness—makes her fit only to live alone. "The older I have grown, the more serious and irremediable have seemed to me the evils and disadvantages of married life, as it exists among us."

To gauge the unhealthy foolishness of such miserable

brooding as this, it is only necessary to glance around, to fix our candid observation on any and every home in which two reasonably assorted people contribute to each other's happiness, and to the well-being of their children. To know how utterly it misrepresents Miss Martineau's actual character, we have only to study the pretty pictures these volumes afford of her Ambleside life—of her genial and hearty expertness as a housekeeper—of her imperturable love of needlework—of her perfect friendliness with her servants—of her perpetual hospitality—of the good homely tact which attached the villagers of Westmoreland to her, as in earlier days her frank intelligence and unresting ear-trumpet had made her welcome in every London house worth visiting. Unless all this is mere fancy, Miss Martineau was the last woman in the world who need have feared or disliked the common chances of matrimony. But from my special point of view, it is more interesting to contrast with these acrid dribblings of her private pen the generous flow of healthy truth which was natural to her when the very same topic presented itself in the course of her literary avocations. In this paper I shall make but one extract from Miss Martineau's general writings; and I make it now. It is from her novel "Deerbrook," and it describes with a beauty that seems to me comparable with anything that is best in fiction the passion which in her *Autobiography* she scans with so dubious and sinister a regard:—

"There needs no other proof that happiness is the most wholesome moral atmosphere, and that in which the immortality of man is destined ultimately to thrive, than the elevation of soul, the religious aspiration which attends the first assurance, the first sober certainty of true love. There is much of this religious aspiration amidst all warmth of virtuous affection. There is a vivid love of God in the child that lays its cheek against the cheek of its mother and clasps its arms about her neck. God is thanked (perhaps unconsciously) for the brightness of his earth on summer evenings when a brother and sister,

who have long been parted, pour out their heart stores to each other, and feel their course of thought brightening as it runs. When the aged parent hears of the honours his children have won, or looks round upon the innocent faces as the glory of his decline, his mind reverts to Him who in them prescribed the purpose of his life and bestowed its grace. But, religious as is the mood of every good affection, none is so devotional as that of love, especially so called. The soul is then the very temple of adoration, of faith, of holy purity, of heroism, of charity. At such a moment the human creature shoots up into the angel; there is nothing on earth too defiled for its charity—nothing in hell too appalling for its heroism—nothing in heaven too glorious for its sympathy. Strengthened, sustained, vivified by that most mysterious power, union with another spirit, it feels itself well set forth on the way of victory over evil—sent out conquering and to conquer. There is no other such crisis in human life. The philosopher may experience uncontrollable agitation in verifying his principle of balancing systems of worlds, feeling perhaps as if he actually saw the creative hand in the act of sending the planets forth on their everlasting way, but this philosopher, solitary seraph as he may be regarded amidst a myriad of men, knows at such a moment no emotions so divine as those of the spirit becoming conscious that it is beloved—be it the peasant girl in the meadow, or the daughter of the sage reposing in her father's confidence, or the artisan beside his loom, or the man of letters musing by his fire-side. The warrior about to strike the decisive blow for the liberties of a nation, however impressed with the solemnity of the hour, is not in a state of such lofty resolution as those who, by joining hearts, are laying their joint hands on the whole wide realm of futurity for their own. The statesman who in the moment of success feels that an entire class of social sins and woes is annihilated by his hand is not conscious of so holy and so intimate a thankfulness as they who are aware that their redemption is come in the presence of a new and sovereign affection. And these are many—they are in all corners of every land. The statesman is the leader of a nation—the warrior is the grace of an age—the philosopher is the birth of a thousand years; but the lover—where is he not? Wherever parents look around upon their children, there he has been—wherever children are at play together, there he will soon be—wherever there are roofs under which men dwell, wherever there is an atmosphere vibrating with human voices, there is the lover, and there is his lofty worship going on, unspeakably, but revealed in the brightness of

the eye, the majesty of the presence, and the high temper of the discourse. Men have been ungrateful and perverse—they have done what they could to counteract, to debase this most heavenly influence of their life, but the laws of their Maker are too strong, the benignity of their Father is too patient and fervent for their opposition to withstand; and true love continues, and will continue, to send up its homage amidst the meditations of every eventide, and the busy hum of noon, and the song of the morning stars."

To say this is less painful—to say it is more beautiful—to say it is cleverer than the remarks on marriage in the *Autobiography*—is not much to our purpose. The view of the love aspect of life here presented, is also, in spite of its glowing style, more true to the facts of intelligent life. "*Deerbrook*" is not by any means a sentimental novel. It rather stands out as pre-eminently one in which fiction was made to serve the severest and most uncompromising moral purpose. There is not a line in it which is not truth itself. But here, in the midst of the author's somewhat arid course, she sees the rock which her true instinct tells her will yield sweet living water if she touches it with the rod in her hand. In her books it is always so. The scene is not always so lovely. The rock is not always so picturesque. The water does not always bubble forth with the same music, or make the same prismatic sheen, or dance from stone to stone with the same living joy, but her pen never passes by a pure spring of truth or moral beauty. No land is so iron-bound that she cannot lead forth from its forbidding heights at least some rivulet of moral refreshment. Her common-sense is strong and dry—her prejudices are vehement—she has favourite men and favourite doctrines. Leave her to herself, and we have seen how she will brood and groan. But set her on her literary pilgrimage, and the most lowering sky will brighten for her, the dullest prospect sparkle, the desert blossom and bear fruit. I will trust her caustic self-introspection, not one hour; her idols and prophets, not one

moment ; her literary instinct, always and wherever it leads her.

Of the working of that instinct little is said in these volumes, but much is revealed. Little is said, because, in all probability, Miss Martineau did not quite understand herself, and imagined her function to have been something rather different from what it was. Much is revealed, because she gives the frankest accounts of the way in which she undertook her books, and the way in which she wrote them. The general theory of her literary life, which she advances over and over again, is that she "had something to say, and, therefore, said it;" but this assumes somewhat more originality than can in strictness be allowed her. That she had always something to say, as she wrote, is true; true is it also that it would have been difficult to find a subject on which the spirit would not have moved her: but it is not true that she was ever full of great ideas of her own which—as the phrase goes—must come out. Such originality as she had lay, first, in expression and illustration; secondly, in being right when more brilliantly imaginative and inventive writers would have been wrong; thirdly, in so rapid an assimilation, and so swift and forcible an utterance of new ideas, that they often seemed more truly hers than those of the persons who had first broached them. In fact, Miss Martineau was a magnificent journalist, and these are the qualities which make great journalists. She was not always writing on the topics of the hour, and it was only after she had made a name by her books that she wrote for a newspaper at all, but in all her work there was the firm practical criticism, the personal and public insight, the quick absorption and fusion of materials, the grasp of subject, and the hold upon intelligent readers, which are marks of journalistic power.

I well know how low the qualities of fine journalism are

rated by many persons of literary taste. There is so much bad journalism that it is not surprising the whole craft is underrated. Moreover, even the ablest journalists have sometimes lacked that conscientiousness which was one of Miss Martineau's best claims to admiration. Those, however, who have had opportunities of judging will agree with me that as nothing is more difficult than to obtain men who in readiness, information, style, and judgment, are really competent for this department of work, so no qualities except those of poets and philosophers deserve higher literary rank. The scorn affected by mere bookmakers for writers in newspapers is truly laughable when we consider the amount of brain-capital which suffices respectively for the two professions. It is a significant fact, that when Miss Martineau, after long being one of the most celebrated authors of the day, was offered the opportunity of writing in the *Daily News*, she eagerly seized it, brought to her new duties precisely the qualities which had always made her pen effective, and ever afterwards spoke and wrote of leader-writing as one of the most responsible and important functions of literature.

Of the prerequisites for all literary work requiring the capabilities and mental habits of a publicist, she was especially possessed of one—that of avidity and appetite for her work. There was probably not a languid half-hour in her life. Her interest in human affairs was constantly keen. To be interested was, with her, to watch, to watch was to understand, to understand was to explain and criticise, to explain and criticise was to produce literary work which will remain to all time a mirror of that most interesting period of our history covered by the names of Melbourne, Wellington, Durham, Brougham, Peel, and Cobden.

Moreover, in her journalistic type of talent, we see an explanation of the manner in which Miss Martineau, as it

were, sprang on a sudden into literary note. Had she been writing anonymously in journals, she might have remained unknown, but her first work took the form of economical tales, and the new idea, at first discouraged by James Mill, but afterwards admitted by him to have worthily succeeded, at once made her famous. But whence the power? To this question we have no reply. The Autobiography is not like John Stuart Mill's. It discloses no gradual enrichment and exploitation of mind. It tells no secrets of instruction and mental exercise. It suggests no growth. The moment Miss Martineau's first words appeared anonymously in print, her brother, unaware of her identity, pronounced that a notable new writer had appeared. Except that she did a little translating to improve her style, there is no trace in her recollections of training, however slight; and in these translations her instinct served her as well as usual, for she aimed solely at terseness, and acquired without difficulty the rare art of making herself briefly and concisely intelligible. Clear-headed, clear-sighted, and plain-spoken, with ready eloquence for succinct yet free expression, and elegance enough to give grace to her simplicity of diction, Miss Martineau stepped full-armed and in full prowess into the literary arena. She was born, not made. From the first moment her workmanship was irreproachable. She scarcely ever refused a literary task, and never made a false step in one that she undertook. Such a life may not have been quite so much on the heights of eminence as she thought it, but it was an infinitely useful life, and one that may encourage and dignify all who, however humbly, employ their powers of insight and criticism on the same level of achievement.

It was characteristic of her that very early in life she ceased copying out what she wrote. There was no use, she said, in copying if she did not alter, and if she altered,

she always had to change back, so she henceforth committed herself, as all practical writers for the Press do, to a single draft; but it was also characteristic that she saw no reason why Carlyle should turn out such bad manuscript—"copy" so chopped and changed, and turned and twisted—except that "the most marked mannerists of the day show most erasures and their proof-sheet most alterations." She herself had fallen, it appears, into mannerism, now metaphysically elliptical, now poetically amplified, and in one instance bordering on the Carlylish; but through all this folly, as well as since, having a style of her own (that is, finding expression by words as easy as breathing air), she always used the same method of writing, always making sure of what she had to say, and then setting it down without care or anxiety. It may safely be said, however, even as respects the most elevated passages of her own works, that these must have grown and flowered under her hand by a process very different from mere swift, straightforward scribbling of what had been previously resolved on, and if her personal sympathies had been more elastic, she would have perceived that such works as those of Carlyle, though less wise than her own, were so much more poetic and profound as fully to account for a more laborious method of production.

Similarly, Miss Martineau lays down very sound principles of work for all ordinary *litterateurs*. She says, very truly, that enormous loss of strength, energy, and time, is caused by people going to work at literature as if its labours were in all respects different from other kinds of toil. She is for intellectual punctuality and industry, and understands by these, not waiting for congenial moods, favourable circumstances, and so forth, but sitting down pen in hand and beginning at a good pace. She herself, she says naively, forgetting that from the nature of her work she always had

her subject before her, has suffered from indolence, irresolution, distaste, and absence of inspiration, but she always found herself in full train in a quarter of an hour; which experience convinced her that those embarrassments and depressions that she saw oppressing many an author were self-inflicted. The mood should be summoned, not waited for. A writer should be the master, not the sport of his ideas and impressions. So far as history writing, article writing, and critical writing of all sorts are concerned, this is probably quite just; but, after all, historians, critics, and article writers—even if they are as successful and original as Harriet Martineau herself—are, at best, of the second literary grade. Creation, whether it be of the poetic, the philosophic, or the fictional order, stands highest, and must have its own rules. No doubt it is absurd enough for mere *litterateurs*, however great, to give themselves the airs of martyr-inspiration; but it is as well to remember that great creative masters may not at all times have their exceptional faculties equally at call.

Miss Martineau did not fully recognise this. Her vast respect for the literary vocation seemed to equalise in her estimation most of those who followed it, and, indeed, Shakspeare among poets, as Canning among statesmen, appears to have occupied alone the summit of her adoration. On this subject she has a curious passage *apropos* of Charles Dickens's love of the drama, in which she confesses that nothing but Shakspeare was in her opinion worthy of the interest which many people take in plays. The faculty of intense admiration was not active in Miss Martineau until she was invited beyond the atmosphere in which she was accustomed to use her wings.

I suspect it was this that made her so easy a victim to the ideas which she embraced in lieu of religion, and so blind a devotee of the person she almost worshipped instead

of God. The extracts from her diaries and papers given by Mrs. Chapman in the Memorials, show, what would not be so apparent from the Autobiography, that during the first thirty years of her life Miss Martineau was a religionist of a very self-scrutinising, anxious type. It was an age of journal-keeping, when it was the custom for good people to write at the end of their day's entries such pious phrases as "May I never again" do this, "May I be enabled always to" do that, and "May I be preserved by grace from" the other. The habit suited Miss Martineau's "anxious conscience" at first, but did not chime in so well with her happier life when she became a successful and useful woman. She had early been troubled, like everybody else, with the mystery of evil, and was not very old when she saw in the doctrine of necessity a supposed solution of many difficulties. What difficulty of any consequence the doctrine of necessity solves—seeing that it cannot banish free-will either from our consciousness, from our language, or from the principles governing our treatment of others—it is not easy to see, though, as far as it recognises the general reign of law, we may freely concur in it. But Miss Martineau derived much sublime satisfaction from it, and was prepared by it to advance to an abnegation of the Supreme Being when a revelation to that effect should reach her.

It is too evident in all this that she was wincing under the comparative powerlessness of the mind in the spiritual region. She was so accustomed to understand everything the moment she clapped eyes on it, that she could not bear the existence of cosmic mysteries, and was ready to adopt any theory that was offered her by anyone, whom, from predisposition, or under any subtle influence, she supposed to know more of these matters than other people. It was in this mood that she met Mr. Atkinson, and became a Materialist and Atheist. She had a perfect right to do so.

Nay, if absolutely convinced, she was bound to do so. This would not be the place for any demonstration of the error of such beliefs. But we are entitled, as a Philosophical Society, to notice the extreme shallowness of the fancies by which Miss Martineau was captivated, and the absolute non-existence of the advantages which she presumed to derive from the Materialistic theory. We are also entitled to any melancholy amusement we may see fit to enjoy at the sight of so great a woman as Harriet Martineau at the feet of so small a man as her accepted teacher. The spectacle presented by the "Letters on Man's Nature and Development" was a very curious one—the poor, weak, mesmeric philosopher, figuring as well as he could in each letter as the instructor, while in each reply his able pupil compacted his ramblings into good, sound English; treated them as she would vague sketches of hints from a feeble editor for whom she was writing leading articles; told him what he meant; said it for him; and made everything lucid and ship-shape, except that not even Harriet Martineau could impart rationality to a book which, while it repudiated miracles, supported clairvoyance; and while it denied there was a God, asserted that Mr. Atkinson, the mesmerist, was a prophet.

Whether there ever was anything in Mr. Atkinson I do not feel quite able to decide. I can only say that I see nothing. Few of us are old enough to place ourselves with sufficient acuteness in the position of the people of thirty years ago, so as to pronounce what there was in the book that was new. The name of Atkinson, however, is not generally included among those of the first great apostles of Materialism; and as we now read his writings, they derive all their vividness from the joy they gave his one distinguished disciple, just as, whatever we may think of Lancelot's shield, there is no resisting the brightness on the face of Elaine. Reading the letters with our present lights,

Mr. Atkinson's share in them seems half trash, half truism ; and though we may admit, with Miss Martineau, the philosopher's clearness, especially after she had touched up his work, it was the clearness of a little puddle, which is very transparent because very shallow. In spite of all the boxes of precious adulation broken over the great man's head in these three volumes, there is not a line of his writing that indicates mental power, while his prevailing dialect has such a snuffle of self-satisfaction as to tempt one to add to Sterne's saying, that if the cant of religion is the worst, and the cant of criticism the most offensive, the cant of conceit is the most intolerable. In one passage of the book Mr. Atkinson is described by the pen of the celebrated, but in this Autobiography much snubbed, Margaret Fuller. She declares him to have a "fine instinctive nature," and says he was—

"A man of about thirty ; in the fullness of his powers ; tall, and finely formed, with a head for Leonardo to paint ; mild and composed, but thoughtful and sagacious ; he does not think, but perceives and acts. Sometimes stationary and acting in the affairs of other men, sometimes wandering about the world and learning, he seems bound by no tie, and yet looks as if he had relations in every place."

Discounting this eulogy, as all must who know Mr. Atkinson by his own pen, we may perhaps conclude that, as there are women's men in society, so there are women's men in philosophy, and that Mr. Atkinson was at this time one of them. In Miss Martineau's presence he could not open his lips to shyly confess that he had read an author she mentioned to him without her falling into raptures. Even she could not stand his hand-writing, but everything else was divine—or would have been if Mr. Atkinson had not expelled the very idea of divinity from the universe. When she has stood the dull steed upon his legs, and fed him from her own beautiful hands with the most fulsome flattery, and

whipped and spurred him into his fleetest amble by her most artful "instigations," she gazes in rapt admiration and looks around, with poor success, for sympathisers, grateful if she only discovers an affectionate friend or "an eminent writer" who did not despise the whole business from beginning to end. As for Mr. Atkinson, he took the matter quite seriously. He delighted his worshipper by vouchsafing to say that the spirit of her novel, "Deerbrook," was the spirit of his teaching, and he graciously described her as not an original philosophic genius, but a person with great artistic power and extraordinary ability to learn, with a still more extraordinary power of seizing on salient points and reproducing in a clear form what had been imperfectly stated by others.

When, after many years' brilliant and solid work, Miss Martineau retired from her position on the *Daily News*, he thus loftily but condescendingly congratulated her. "Now, my dear friend, you are one of us. I hail you among the noble band of lookers on." With this Pythagorean compliment Mr. Atkinson makes his exit from the scene, except that he is again seen in a letter written after Harriet Martineau's death, in which he claims to have anticipated Professor Tyndall, Dr. Maudsley, and Mr. Lewes, while he insinuates that Dr. Carpenter and Sir William Hamilton stole from him unconscious or automatic mind, and, being in a profusely thankful mood, rejoices that Professor Huxley has actually expressed an interest in mesmerism.

The extraordinary infatuation of Miss Martineau for this gentleman led to her alienation from her distinguished brother James. Whatever might be said of her brother's opinions, he was a wise man who could not see folly without laughing at it, or sciolism without piercing it with his rapier-pen, or a profane and shallow cosmogony without rebuking it in accents of grand severity. He neither lost nor forgot

his respect for his sister, but he administered to the "Letters," and especially to Mr. Atkinson in the pages of the *Prospective Review*, a most severe castigation. He showered strokes of satire on the element of credulity which contrasted so oddly with the book's uncompromising scepticism. "Through the whole exposition," he said, "flows a perpetual stream of physical miracle. The authors appear to live exclusively among people who see through brick walls, taste and hear across half the land; who will send you any given pain by the penny post, and write your whole biography from a bit of your old shoe; who have electric telegraphs laid into the future and into the past, and can report histories they never learned, and coming events that have made no signs of their approach." What was far worse than this banter, Mr. Martineau suggested that his sister, by a tyrannical exercise of mesmeric sympathy, had brought Mr. Atkinson's English to the standard of her own, and he proved this by quoting a previous writing of that gentleman which had almost every grammatical fault. "But enough," he exclaimed, "of this hierophant of the new atheism. With grief we must say that we remember nothing in literary history more melancholy than that Harriet Martineau should be prostrated at the feet of such a master; should lay down at his bidding her faith in moral obligation, in the living God, in the immortal sanctities; should glory in the infection of his blind arrogance and scorn, mistaking them for wisdom and piety; and meekly undertake to teach him grammar in return. Surely this humiliating inversion of the natural order of nobleness cannot last. If this be a specimen of mesmeric victories, such a conquest is more damaging than a thousand defeats." Perhaps it was not brotherly to write thus, but no other exception can be taken to it than that it came from James Martineau's pen.

His sister never forgave the appearance of this article,

but she is becomingly reticent on the subject in the Autobiography, and the Memorials do not convict the *Review* of injustice.

When we find such a woman as Miss Martineau treating the change in her views brought about by her acquaintance with Mr. Atkinson as a great emancipation, it is important to know from what she considered herself to be freed. She tells us that till then she had no idea of what life might be in freedom, vigour, and peace of mind. She attributes to her new views "the nightly mood which yielded her such lofty pleasure, under the stars and within the circuit of the solemn mountains." Something, it is clear, gave her the enthusiasm of serenity which Christians derive from their religion, and which Spinoza found in the sublimities of Pantheism. But what was it? and wherein was it so diametrically opposed to Christianity that she could not mention her earlier faith without hot repugnance? And why was her liberated soul lacking in the sweet spirit of Spinoza which enabled him, Pantheist as he was, to join in the simple religious services of the common people and to agree with nearly everything their pastors said?

The source of her satisfaction is very clearly indicated in the following passage:—"It is a short way up to the blank wall of human ignorance; but we can separate on our own side of the blank wall what is actually known from what is becoming revealed; and both from what we can never know. The wall itself is destined to be forced and the limits of ignorance to be set perpetually further back, while we can never be any nearer to knowing what our faculties are unable by their constitution to apprehend. While the disciples of dogma are living in a magic cavern, painted with wonderful shows, and the metaphysical philosophers are wandering in an enchanted wood, all tangle and bewilderment, the positive philosophers have emerged upon the broad, airy, sunny com-

mon of nature, with firm ground underfoot and unfathomable light overhead." I might retort upon this bold and telling *credo* that it is positive sciolists, not positive philosophers, who leave out of their reckonings the laws of mind and the proved necessities of the conscience. But I confine myself to the observation that, even if sound in itself, Miss Martineau's new faith in ultimate human knowledge could not entitle her in the mean time to placard her "blank wall of human ignorance" with lampoons and libels on the more religious beliefs of others.

A woman of such candour—as we are well instructed by the example of John Mill, who arrived at far healthier sensibilities from a less likely starting-point—should have felt no temptation to describe actual Christianity as representing God as "an unmitigated tyrant and spontaneous torturer," and the sweeter and nobler attributes of Jesus as "only deepening the opprobrium of the divine cruelty;" and she lived long enough to read in Mill's last essays how even in the absence of dogmatic faith in immortality the doctrines and hopes of Christianity presented to the greatest intellect of her time the ideal spiritual state which it was most tempted to covet. Unbelief one can respect, but where was the philosophy of this inveteracy against a faith which, as a matter of fact, yields to millions a peace passing understanding as greatly as that which Miss Martineau derived from hers?

At one time—when her book on Household Education was well received by Christian parents—she was on the verge of discovering that such persons could enjoy all her pen had to offer them without parting with their religion; but she passes the incident by with a sigh of egotistical gratulation, and gets no glimpse of the lesson it should have taught her. Although, according to her own creed, it could not possibly matter in what mood, so it were comfortable, a fellow-creature passed into senseless dust, she was positively miserable

because she had not in a very affecting instance thrust her ideas of personal extinction upon a dying man. He was a town missionary—"such a face—so full of life and happiness"—who idolised her, as indeed so fine and noble a spirit was worthy to be idolised. He fell into rapid consumption, and was dying, when it was suggested that his idol should write to him. She did. She sent him a beautiful letter and a sincere one; no doubt put her best and most loving tact into it—as, thank Heaven, many a woman can who is not a great author—and yet did not pretend what she did not believe. "There was not a word about the future, or of God, or even Christ," but, reaching this poor fellow on the last day of his life, it refreshed and solaced him, and he revived for a few moments in his dying torpor, and begged his wife "to tell all who loved him of 'this last flush on his darkness.'" Could any story be more beautiful? But what says the heroine? "This is dreadful pain to me. I feel as if I had told him a lie for my last words to him. It would have been hard and unkind not to write, and it was impossible to disturb his life at the last. Yet I feel that that letter did not carry my real mind to him, and does not to the many who are reading it." Even here there is a vein of gentle feeling; but years after, when scepticism and scorn had had more time to vulgarise her, Miss Martineau wrote that it was cheering to feel that her mind was now stronger, and that she "was released for ever from all danger of misleading missionaries or any body else by letters of sympathy under solemn circumstances which they would interpret by their preconceptions." I cannot tell how such expressions will be regarded by my audience. I can only protest in the name of philosophy against the supposition that free thought need be thus coarse-grained and ill-conditioned. No wonder her friends found her new doctrines "vinegar mingled with gall."

Let us take another example of her jaundiced condition

of mind. She heard the "Messiah" performed at the Coronation, and this, of course, was long before she met Mr. Atkinson or embraced his opinions. But she was already on the declining plane, and disposed to carp at other people's devotions. She considered the oratorio saddening and full of shame as an act of worship—ridiculed the representation of the Supreme Being as King of Kings—and winced at the attribution to the Great First Cause of military and aristocratic rank and regal prerogative after what she considered a "Jewish or Heathen" fashion. She must have known perfectly well that by the growth of religion (whether under inspired direction or not is immaterial to the argument) the ancient Hebrew phrases had lost the narrow meanings in which they had been used—if they had so been used—by a primitive people, and that not a person who now heartily joined in them did so otherwise than in the loftiest and most spiritual sense. Is it philosophical to ignore the noble and expansive belief into which a rudimentary faith has grown, and to tie a modern and enlightened generation down to any small or too literal conceptions which the elastic outline of rites and phraseology now amply sufficing for the grandest ideas may originally have only just enclosed? Miss Martineau was a warm admirer of Comte, but she had too little of his tolerant historical appreciation. The only thing she retained from her religious education was its narrowness, and the freer she thought herself the narrower she became.

It was easy to express the change which had passed over her in the technicalities of the positive philosophy—which always becomes a jargon when used by real people in reference to real stages of their mental history—and accordingly there are several passages in which much is made of her having got out of the metaphysical region; and if this had been merely rejoiced over as an advance in theological theory, it would not have been a proper subject for us to discuss in

this Society. But to understand Miss Martineau's feelings, we must note her less formal and more expressive utterances, from which we gather that what delighted and emancipated her was not a mere approach to or even attainment of abstract truth, but the getting rid of free-will and moral choice. Materialism taught her that the whole action of the human being was automatic, and the consequence, as she expressed it, was that "my friend and I" in "our emancipated maturity agreed that not for the universe would we again have the care of our souls upon our hands."

Surely this was a strange—nay, an inconceivable—subject for congratulation. Understand by the care of one's soul the mere escaping from an obscure and superstitiously conceived future perdition—or grant that a virtuous person may escape responsibility for his soul on a principle which will not also license a wilfully vicious person in the indulgence of immorality—and we might comprehend Miss Martineau's glee in making believe to be irresponsible; but the latter supposition is impossible, and the former, though a view of salvation, is not that which any religionist worth arguing with adopts. Although by a fiction of the mind she may have got rid of certain stereotyped anxieties, such a woman as Miss Martineau could never have obtained any satisfaction from not having her soul to take charge of if she had seen in herself the corruptions and shortcomings she knew to be in her moral inferiors. That she composed her moral philosophy on principles which, unless we juggle with words, could only work out tolerably in natures like her own, proves the fallacious character of her new content.

A South Sea islander, bathing in warm seas, and living on luscious fruits, might be capable of such satisfaction, because insensible of evil as of good. But Miss Martineau was so rigidly pure that even Thackeray's "Vanity Fair" appeared to her too tolerant of evil. She was so energetic

and benevolent that in the height of her fame, when a letter was posted addressed to the "Queen of Philanthropists," the postmaster superscribed it, "Try Miss Martineau." As long as she could move she continued the most devoted labours for the good of the people among whom she lived. And what did she aim at? Treating them as children? Shielding them from all temptations? Fencing them round from evil? By no means. Her endeavour was to arouse their moral sense, to make them choose the better part, to induce them to prefer good habits to bad. Pray what is this but persuading people to take good charge of their souls? For though, in a narrow sense, such phrases may refer to a mere avoidance of prospective perdition, the Christianity which Miss Martineau despised coincides with the philanthropy she practised, and differs from the false philosophy she fancied she believed, in making moral perfection the highest object of all human endeavour, and moral improvement the surest route even to material happiness.

She might think she had got out of the domain of moral embarrassment because a trick of thought, taught her by a rather silly but so far useful, gentleman, had extirpated morbid preoccupations which her own much greater wisdom had been too much engaged otherwise to solve. But there was no change in her writings or in her life, and hardly a word fell from her pen or lips that did not tend to stimulate others to a right, a persevering, an ardent exercise of that moral choice which she found a strange peace in believing was impossible either for herself or anyone else.

Such are the inconsistencies into which even the greatest and most accurate minds must be betrayed if, instead of acquiescing in the insolubility of the problem of human responsibility, or treating it apart as a subject for metaphysical ingenuity, they attempt to apply in any sort of practice a theory which shallowly pretends to clear up the mystery.

Happily such cases are rare, and they are never complete. Here is a lady pretending that none of us have any choice how we act. But in one page of her Autobiography she nearly explodes with suppressed anger because Lord Lansdowne shows civility to her as an author and not as a lady. On another she flies into ecstasies over the rare and active virtues of her friend Mrs. Chapman. On many others, with true pathetic indignation, she fires up amidst tears at the shameful treatment that broke the heart and cut short the life of Lord Durham. And on almost every page she exhibits a lively passion for people who do well or against people who do ill, which is manifestly a preposterous disturbance of her philosophic quiet, unless those whom she blames or praises had free choice in their conduct.

A quibbler may indeed reply that Miss Martineau could no more help being indignant than the wrong-doer could help doing the wrong; but the sufficient answer is that Miss Martineau's indignation is, in many cases, justified by abstract principles of right which we all acknowledge, yet would not be justified in so doing if it were not assumed that the acts done were wilful and responsible. Blame and moral judgment—still more the idea of righteous punishment in every form—are intruders upon the principle from which Miss Martineau supposed she derived her happiness; but if they are expelled from human life, the residue is an inconceivable chaos.

But, in truth, her supposition that her happiness was thus derived was entirely fantastic. To those who can read the woman through the veil of her Autobiography it is evident that what gave her relief was that—*post hoc*, not *propter hoc*—after accepting Mr. Atkinson's formula as a sort of charm to mumble when she felt low spirited, she gave up the cruel and fretting self-introspection which had been the bane of her existence. She had never needed, though she had

often worried herself with the check or spur of self-examination. She would have been a female Wellington in point of natural devotion to duty as a matter of course, if she had been as free as the Iron Duke from self-consciousness. But in one form or other this miserable quality passed into habit plagued her till she was nearly fifty, and when it ceased to annoy her she stored it up for her friends, for whom there is in these volumes a whole reservoir of vexation. A book one-half of which is rendered gloomy by gratuitous sentimental troubles, the other half much deformed by shrewish censoriousness, and the whole vulgarised by an offensive assumption of spiritual deliverance and superiority, which will not bear a moment's examination, can hardly be considered a fitting monument of a life so noble, so full of good, so free from public errors as that of Harriet Martineau.

If it is necessary for me to defend the occupation of so much of your time with matter of a *quasi*-religious quality, I plead that the main substance of feeling in the Autobiography is an enthusiasm for the extinction of religious hopes and influences. That enthusiasm I should take to be at once anti-human and unphilosophical, even if religious hopes were vain, because religious influences are certainly excellent, and contribute more than anything else to human well-being. Miss Martineau's right to her opinions no one will question, but it is necessary, in the face of formal statements by so eminent a person, to deny, first, that she held her opinions consistently; secondly, that they could be held with practical consistency by any intelligent moral being; thirdly, that it was from those opinions that she really derived the felicity of her later years; fourthly, that any but the most delusive comfort can be got from the particular opinion on which she laid most stress; fifthly, that any workable system of moral philosophy requires, or that any human interest, intellectual, moral, or social, can be pro-

moted, or any practical human difficulty avoided, by the abandonment of Christianity; and lastly, that any perceptible progress has ever been made by anyone towards the clearing up of the mystery which surrounds the conscious freedom of a large proportion of human volitions, much less towards such a disproof of that freedom as would destroy moral responsibility. These protests are more essential in the cause of political and moral philosophy than in that of religion. Religion will always take care of itself, but the advances of mankind in the purest intelligence and conscientiousness, in lofty principles of citizenship, and in true liberality of opinion, will always be hindered so long as hostility to religion is vulgarly considered the attitude to which the highest enlightenment is prone.

Having acknowledged the somewhat painful and lowering impressions which the Autobiography and Memorials have produced, the best thing we can do is to rehabilitate from the brighter pages of the book that conception of the true Harriet Martineau—if I may employ a useful sporting phrase for which there is, at any rate about boat-race time, good University authority)—Harriet Martineau in her “public form.” For this purpose we may have recourse to the glowing descriptions of her rapid success at the first onset in London—when, true to the instinctive type of her talent, she found she had been writing good political economy without knowing it—and the fact that from that moment the demand for her work never ceased, and its effectual quality never deteriorated. Like most people who have faculty as well as desert, she honestly enjoyed being made a fuss with, and her Autobiography abounds with frank records of the pleasure she experienced in being buzzed around by some of the greatest men of the day. It also affords many explicit testimonies to her high usefulness and distinction. Brougham snarled over the complete eclipse of the grand Whig Society

for the Diffusion of Useful Knowledge by Miss Martineau's single endeavours. Lord Jeffrey would have gone a long way to "kiss the hem of her garment, or the hand that delineated her glowing and lofty representations of purity and noble virtue." The energetic and patriotic government of Lord Melbourne, full of great projects of improvement, came incessantly to this clever young woman of thirty for counsel and for countenance; and when she had grown older, and was moved to much characteristic suffering by the personal suspicion and hostility between Peel and Cobden, it was to her private remonstrances the great men listened. Peel made amends, for which Cobden had long waited, and sent Miss Martineau a marked newspaper with his autograph, containing a report of what he had said, while Cobden, ill and weary, but delighted, stayed up at three in the morning, after the House, to write her a little scrawl to the effect that he could not sleep till he had sent her the blessing on the peace-maker; that his mind was eased of a load which had burdened it for many miserable years; and that now he should be a new man. O'Connell, convinced that Ireland suffered from vulgar and violent advocacy, did himself and Harriet Martineau honour by begging that one who had proved in America how well she could understand another country would study and report upon Irish affairs upon the spot. Charlotte Bronte shared few of her opinions, but cherished "the highest respect for her union of the highest culture with the nicest discharge of feminine duties, and for her person, practice, and character in every way." Sidney Smith pronounced her "safe" when she had gone through such a season as no girl ever knew before, and "kept her own mind, manners, and voice," and on another occasion went higher, and called her "a true heroic nature." Carlyle curiously observed that she was the only instance he knew of clear activity being compatible with happiness. Guizot made

a biography of her the first of a series he was issuing as Minister of Public Instruction. Mr. Atkinson said, oddly enough, that she was a master mind, and sat at the feet of no one. Mr. Forster, during the American Civil War, declared that it seemed as if Harriet Martineau alone was keeping this country straight. Florence Nightingale, in spite of her friend's atheism and her own fervent Christianity, wrote that Miss Martineau had the deepest religious feeling she had ever known, and that to the last it showed itself "in the sense of good working out of evil into a supreme wisdom, penetrating and moulding the whole universe, and in the natural subordination of intellect and the intellectual purposes and intellectual self to purposes of good."

Among these testimonies we come upon perfectly delightful pictures of the frank and high-toned hospitality of The Knoll at Ambleside, and also upon graphic descriptions of Miss Martineau's appearance and ways. When Hawthorne saw her she was a large, robust, elderly woman, plainly dressed, but with such a kind, cheerful, intelligent face that she was pleasanter to look upon than most beauties; the most continual talker he had ever heard—really like the babbling of a brook, but very lively and sensible; and all the while she talked moving the bowl of her ear-trumpet from one auditor to another, so that it became quite an organ of intelligence and sympathy. If you had any little remark to make you dropped it in, and she helped you by the delicate appeal of the trumpet as she slightly directed it towards you, and if you had nothing to say, the appeal was not strong enough to embarrass you. "All her talk was about herself and her affairs, but it did not seem like egotism, because it was so cheerful and free from morbidness." This woman atheistical? Hawthorne would not think so. In spite of her lack of beauty, Mrs. Chapman found her presence from the first attractive and impressive, and delighted especially in

her rich brown, abundant hair, and her eyes light and full, of a grayish, greenish blue, varying in colour with the time of day or with the eye of the beholder, steadily and quietly alert, as if seeing something where another would have found nothing to notice. "You might walk the livelong day in any city streets, and not meet such a face of simple, cheerful strength, with so much light and sweetness in its play of feature." "Her one great gift," says her memorialist, "was utterance: not rhetoric, not elocution, not eloquence, not wit—though her talk was full of short corner touches—but the faculty of rapidly communicating thought and feeling." We can well imagine the pleasure with which her warm friends, such as Macready, when she had retired to the Lakes, "looked with wonder at the brown hue of health upon her face, and saw her firm and almost manly strides" as she walked about to show them the beautiful sights among which she lived, and amid which, soon after, she began—but mistakenly—to expect very early to die.

The delightful activity of this great woman's mind, and her almost universal sympathy with all subjects of human interest, is most happily exhibited in her criticisms of her contemporaries. Macaulay got least justice from her. He was too absolutely a Whig, and she saw nothing in him but irresistible speech and a brilliant power of historical romance. To Bulwer she was kinder. If she quizzed him as he sat on a sofa like a Sultan being petted by beauties, she saw he had "insight, experience, sympathy, letters, and an irresistible impulse to utterance and industry," and possessed "one of the most promising natures of her time." His "friendly temper and simple manners often left her mourning that such a being should allow himself to sport with perdition," for he "had the makings of a good man." Of Mill she has little to say, except that his voice was feeble and his Autobiography melancholy. She enjoyed Sidney Smith's wit, and

detected what was less commonly observed—his seriousness. The earlier Carlyle lives in these pages in many a vivid trait, and always amid a halo of kindly admiration. Lord Houghton is a prime favourite, for good and true grounds assigned. Babbage figures well, especially when patiently enduring the questions of a lady who wound up by asking him whether, if he put the wrong question into his calculating machine, the right answer would come out. Lyell's Scotch prudence is seen giving way to natural geniality and an expanding liberality of opinion. Allan Cunningham was precisely the human example she had most wished to see—a hard-handed workman, with letters and poetry opened to him by the life of books. Croker she justly hated. Lockhart, upon much provocation, she cruelly compassionated. Moore she freely despised. Mrs. Barbauld she deemed a genius. Miss Bremer she coldly patronises. Margaret Fuller she resolutely plants her manly foot upon, and seeks to crush. For Mary Wollstonecraft she calmly makes allowances on the ground of constitution and singular environment. Thackeray she could not believe in till she read "Esmond," when she saw his "rich, ripe wisdom, and the fertility with which he opens glimpses into a multitudinous world as he proceeds." But in spite of Laura Pendennis and Esmond's "dearest mistress," she gathered from their author's manners, as from his books, that he could never have known a good and sensible woman. She enjoyed her face-to-face intercourse with Dickens, and took strong delight in some of his books, but she missed the pure broad daylight of actual existence both in his scenery and characters, and when she had done much work for him, parted from his periodical in just disgust because he proved himself so bad a Liberal as to pander to Protestant prejudices by gross and reckless articles in its pages.

Scott's "Bride of Lammermoor" she re-read with asto-

nishment that she could no longer enjoy it. In Jane Austen she found two touches, and only two, of pathos. Of immorality in novels she wisely said that tales were not to be judged by their fitness for children; that she objected to no real subjects into which pure moral feelings of any kind could enter; and that the morality or immorality of fiction depended on whether its spirit was pure and benign, whether immorality was treated with foul gusto or with a mere view to delineation. She was in time to see the weird face and hear the dreamy voice of Coleridge, and thought his utterances about equal in wonder to the numerical results of Babbage's machine. Wordsworth does not appear to advantage in these volumes, because Miss Martineau only dwells on her poet-friend's least imposing characteristics. Of the statesmen of her time Peel was her favourite. For the Whigs she had no pity. Nor for Edward Everett of Boston. For Charles Sumner she had a great deal. But Miss Martineau's pity was by no means "a sweet boon."

There are very sharp sayings in this book, sharper sayings, let us hope, than were often dropped into the world-famed ear-trumpet. Nothing more acrid has been written than Miss Martineau's bitter satire on Unitarianism, a piece of writing not suitable for notice here, but well worth a glance from those who are interested in the differences of English sects. Few better hits have ever been made than the remark about Robert Owen that he was not the man to think differently of a book for having read it. And what a pregnant *mot* this is—a chance line in a diary: "Odd sometimes to see thoroughly vulgar people. It enlarges one's ideas." The good things, as distinguished from merely bitter things, are of course much more numerous. There is a criticism, wise on the whole, though very stern, on some of Dickens's humanitarian fiction, expressed in a wish that he would abstain from a set of difficult subjects on which all true

sentiment must be underlain by a sort of knowledge which he had not. From old Miss Berry, with her startling bad language, through the whole range of her seniors and juniors, Miss Martineau has something lively to say of almost every personage visible or knowable while she was in society, and though she seldom kindles into warmth, when she does so, as in the case of Lord Durham—the most unfortunate statesman of Parliamentary times—there is a depth of feeling which saturates with true pathos subjects commonly thought ungenial or out of the atmosphere of tender emotion.

Miss Martineau is not to be understood, however, by those who cannot appreciate a noble enthusiasm on public questions and susceptibility on public affairs as keen and sensitive as ordinary people cherish on matters of self and family and friendship. Proofs of this, which glow abundantly on these pages, will be regarded differently by persons of different opinions, but everyone with a quickened and cultivated sense of citizenship will admire, without reference to opinion, the public zeal with which the heroine of the *Autobiography and Memorials* was always aflame. We see it in her sentiments on American slavery; in her mountain-moving faith in political economy; in her admiration of Peel—as her *History* revealed an earlier worship of Canning; in her fierce hostility to Russia, which in her time was still what Continental Liberals even now believe it to be, the sworn enemy of liberty and democracy; in her uncompromising aversion from all projects for making people good by Act of Parliament, or, as she phrased it, undertaking to provide by law against personal vices; in her adoption of the doctrine—all political economist and anti-Socialist as she was—that a deep modification of the institution of property, certainly in regard to land, and probably in regard to much else, must be an element in the progressive improvement of society; and in her warm advocacy of the movement chiefly

identified with the name of Mrs. Butler. Whatever may be our judgment on this last topic, the biographer of John Grey of Dilston, and the autobiographer of Harriet Martineau might well be proud of and ought to be honoured for their common heroism; and the friends of Miss Martineau may be permitted to cite her hostility to the Acts these ladies opposed together as a proof that her materialism had not indurated her moral sense, or atrophied or coarsened her spiritual fibre.

So far as the book is a history of Miss Martineau's life-work it is singularly barren, just because that life-work was of a kind not lending itself to narration. All you perceive is that here was a woman of commanding mind, penetrating insight, fluent pen, and almost infallible judgment, who was constantly finding new themes on which to instruct the public—for whom publishers and editors were always eager to afford channels of influence—whose ready tact and firm, quick apprehending glance enabled her to surround herself as surely and promptly with the best material as a Frederick the Great would do in war—and whose calibre of mind enabled her to appropriate as if by inspiration, and to use with straight aim and success, and always in the cause and for the good of the public, the best extant knowledge and theories.

Meanwhile, if you will listen to her—and you cannot help it—she will tell you, now her potent public personality has disappeared from our midst, whom she knew and what she thought of them; who libelled her and who praised her; whom she visited, and why she would not accept civilities from Lord Lansdowne. She will tell you how she expected to be treated as a lady and not as an authoress, and yet did not like to be talked to as a woman and different from a man; how kind old Samuel Rogers and “contradictory” Henry Hallam were to her, and how she shamed Dean

Milman at a breakfast table by arguing that if a man had no heart he could not be happy. You will find her shedding tears over Comte as she translates and condenses his philosophy; curing herself of what she considers the Christian foible of regarding illness as a special moral discipline; never tired of detailed and local philanthropy; always recurring to fancy needlework as a solace and occupation; managing her house to perfection; the friend and confidant and gossip of her servants, who evidently stayed with her a long time and became sincerely attached to her; and altogether leading a vigorous, various, strongly-featured, and, in a good sense, wilful private life—a life with some caprices in it, but no caprice that did not own the check of conscience and assume to be defensible by reason.

If you want to laugh at her a little, observe how seriously she resents Petruchio's treatment of Katherine, and, by implication, condemns Shakspeare's "Taming of the Shrew;" or notice how she thinks a new plot for a fiction an impossibility because she cannot think of one; or listen to her strange argument, that though a philosopher may cite "the fair humanities of old religion," or quote the Pagan classics with gusto, he must not enrich his language with Scripture phraseology. But on the whole you will be little disposed to make merry with the foibles—happily till now only guessed through a veil of seclusion, tinged with a supposition of eccentricity—of so great and useful a woman, who knew and said it was her mission "to teach principles," and who, in her work for the public, fulfilled that mission as no woman and few men have ever done before.

Rather attune your minds for a moment to the spirit of the simple life she sketches so beautifully in her account of her latest days of work—work done, as she thought, under the very shadow of death, but with a serenity never clouded, and an enjoyment that lost neither its avidity nor its

nobleness. Her letters and her daily leading article occupied her morning, and "there was time for exercise and neighbourly business before dinner." Then there was her favourite "womanish" resource—the adjective is hers—of wool-work, many a square yard of which was invisibly embossed, she said, with thoughts wrought in under the various moods and experiences of a long series of years. In winter evenings she lit her lamp with alacrity and dreamed over her needle-work till the second post brought her a London newspaper and reminded her of tea. After tea, if there was news of the war, she called in the servants, and the great atlas was brought, and they all studied together the chances of the campaign. Then "there was an hour or two for Montaigne, or Bacon, or Shakspeare, or Tennyson," or "the last new book from London." And when the house and neighbourhood were asleep, there was half-an-hour on the terrace, or, if the weather was too bad, in the porch—whence she seldom came without a clear purpose for next morning's work. "On my terrace," she writes, "there were two worlds extended bright before me, even when midnight darkness hid from my bodily eyes all but the outlines of the solemn mountains that surround our valley on three sides, and the clear opening of the lake on the south. In one of those worlds she saw the scenes of her travels—"now the magnificent coasts of Massachusetts in autumn, or the flowing swamps of Louisiana, or the forests of Georgia in spring, or the Illinois prairie in summer, or the blue Nile, or the brown Sinai, or the gorgeous Petra, or the view of Damascus from Salahiey, or the Grand Canal under a Venetian sunset, or the Black Forest in twilight, or Malta in the glare of noon, or the broad desert stretching away under the stars, or the Red Sea tossing its superb shells on shore in the pale dawn." This was one world that "came up into light" amid the darkness "at her call." The

“other and finer scenery” was of the world of science “only beginning to be explored,” the “imagery of whose glorious hierarchy” had been impressed upon her by her long study of Comte. It was truly, she said, “an exquisite pleasure to dream, after the toil of study, on the sublime abstractions of mathematics, the transcendent scenery unrolled by astronomy, the mysterious invisible forces dimly hinted to us by physics, the new conceptions of the constitution of matter originated by chemistry, and the inestimable glimpses opened to us of the nature and destiny of man by the researches into vegetable and animal organisation.” “Wondrous beyond the comprehension of any one mind was the mass of glorious facts and the series of mighty conceptions laid open, but the shadow of the surrounding darkness” rested “upon it all.”

From the peopled and fancy-painted shadows of that darkness—destined withal to clear away at the dawn—we can imagine her stepping back into the lingering light of the home her memory hallows, with eyes drinking rapidly in the signs of life and duty and friendship which she loved even better than the poetry of great silences and shadows, and laying down her head, at length for the last time, on the pillow of well-earned repose. She was a great woman, in spite of the littlenesses of this book, and if any may gainsay her greatness, it must be those who have not lived for mere comfort, or even for the mere personal peace of a religious life. It is easy to wish that she had been free from, or had even concealed for ever, the frailties of her temper and the infatuations of her poorer hero worship, but it is not easy to lead a life so proof as hers was against self-reproach, or so purely dependent for its happiness upon the highest joys. With less indulgence of an egotism which tended to become sour, and a humbler apprehension of mysteries which no human being can either ignore or rationally presume to have

solved, Harriet Martineau would have been entirely worthy to the last of the majestic eulogium of Monckton Milnes:—

“Because the few with signal virtue crowned,
 The heights and pinnacles of human mind,
 Sadder and wearier than the rest are found,
 Wish not thyself less wise nor less refined.
 True that the small delights that day by day
 Cheer and distract our being are not theirs;
 True that when vowed to virtue's nobler sway,
 A loftier being brings severer cares:
 Yet have they special pleasures,—even mirth
 By those undreamt of who have only trod
 Life's valley smooth; and if the rolling earth
 To their nice ear have many a painful tone,
 They know man does not live by joy alone,
 But by the presence of the power of God.”

NOTE.—It did not fall within the scope of this Paper to discuss Miss Martineau's state of health from the time when she resorted to and believed she was greatly relieved by mesmeric treatment; but I cannot help expressing regret that Mrs. Chapman did not see fit to include in her volume of Memorials some record of physical facts, ascertained since her friend's death, which bear strongly on this subject, once discussed with much excitement and acrimony. The supposed cure of Miss Harriet Martineau, in 1844, by mesmerism has been clearly accounted for in a communication made to the Clinical Society of London by the eminent T. Spencer Wells, F.R.C.S. (See *British Medical Journal*, May 5th, 1877.) Inquirers may there learn the history and course of the oppressive internal disease under which she laboured for probably between thirty and forty years—a disease which, in its natural progress, passed through a period of alleviation and apparent cure; which, further on, might probably have been successfully eradicated, but which was, in fact, permitted to run its course. The observation has naturally occurred to several persons who have become aware of the true state of the case, that it to some extent explains much in her later life, and in the Autobiography, which those who most admired her most lament.

POPULAR ERRORS ABOUT POISONS.

BY EDWARD DAVIES, F.C.S.

THERE is no form of crime which so powerfully affects the imagination as poisoning, which excites such terror, or stirs up such violent indignation against its perpetrator. To take away human life by deeds of violence is in comparison a matter of much smaller guilt, for we may find some excuse for the man who, at all events, gives one a chance of resistance, and who may act on the spur of revengeful passion, or who is carried by fear of detection or capture to kill his victim. But poisoning, by its very nature, excludes the idea of want of premeditation ; there must be the procuring of the poison, the patient waiting for a favourable opportunity for its administration, the calm watch over the action of the deadly agent, perhaps the repetition of all this from a first failure. Then the defenceless state of the victim, who unconsciously receives from professedly friendly hands the deadly draught or poisoned food, or is unknowingly made the instrument of his own destruction, makes us furious against this violation of every principle of manliness and fair-play, deprives the poisoner of every spark of sympathy, and makes us consider him as an enemy of the human race, at whose detection and punishment every one rejoices. This creates the intense interest which poisoning cases excite, and leads us to devour every detail of the trial. I need only allude to the Palmer case, not to speak of more recent trials, to prove that poisoning cases arouse the public mind far more than other kinds of murder. We all feel that against this peril all precaution is in vain, and, therefore, we feel anxious

that the guilty shall not escape, and that certain detection shall render the crime too dangerous to practice. This also helps us to understand the panics which in old time were caused by the explanation which was given of epidemic diseases of an unknown type, when poisoning of the wells, or the scattering of poison in the streets, was at once set down as their origin, and innocent persons were ruthlessly murdered as being the diabolical agents if they were seen doing anything which a frenzied populace thought suspicious. Fiction has seized upon this, and Eugene Sue, in his *Wandering Jew*, has vigorously painted the insane terror caused by this idea. Sudden deaths were generally set down to poison, and many characters of history have been held up to reprobation as removing their enemies by this means, which more knowledge of science is now showing was probably undeserved.

Terror and unreasoning panic have produced an abundant crop of erroneous opinions respecting poisons, and as some of these have fallen under my own observation, I have thought it not unworthy of the consideration of this Society, how these have arisen, and how they may be removed. I may remark that I have found a great dearth of information in books on this subject, and must crave your indulgence if my remarks lack the fulness of illustration which they require, and also for drawing from works of fiction examples in justification of my statements. Fiction is, indeed, almost the only form of non-scientific literature in which allusion is made to poisoning, and I have, therefore, not scrupled to use it. Here there is almost an excess of material, and if I have only made use of two works, one by a popular English, and the other by a world-renowned French, author, it was because these gave me sufficient illustrations of this type.

1.—That every poison has its antidote.

An antidote is something given to counteract the effects of a poison, and one fallacy of very early date was that for every poison Providence had provided an antidote which, taken at almost any time before a fatal termination, would arrest its action and restore the patient to health. In order that this intention should not be defeated it was also an article of faith that the two were invariably to be found in the same neighbourhood, and the only thing wanting to secure the desired immunity from death was some mark whereby the antidote could be recognised. Unfortunately, this link is wanting, and we now know that antidotes, in the sense given above, are, alas, almost unknown.

Shakespeare, in *Romeo and Juliet*, says :—

“ Within the infant rind of this small flower
 Poison hath residence, and medicine power :
 For this, being smelt, with that part cheers each part ;
 Being tasted, slays all senses with the heart.
 Two such opposed foes encamp them still
 In man as well as herbs.” Act ii., Scene 3.

Again, the close connection between the bane and antidote is exemplified in the following extract from Paris's *Pharmacologia* :—“ For the same potent reason were the hairs of the rabid dog esteemed the true specific for hydrophobia.” From this, I suppose, we get the phrase, “ a hair of the dog that bit you.” Perhaps the most perfect example was that the ashes of a witch, thoroughly burnt at the stake, were a certain defence against witchcraft. No one who has read the fiction supplied by instalments in cheap publications can have failed to meet with the villain who seeks to remove his enemy by dropping some colourless liquid into his food or drink, and who is as invariably checkmated by some mysterious individual who detects his nefarious designs ; and when the poison is well on its deadly way, gives a few drops of another

colourless liquid, and restores the hero or heroine forthwith, only to meet with another danger "in our next."

The strength of this belief may be gathered from the long life which that extraordinary mixture known as "Theriaca Andromachi," said to have been invented by Mithridates, King of Pontus, and discovered among his papers, has had. Galen says, that whoever took a proper quantity in the morning was insured from poisons for the whole of that day, and Celsus asserts that Mithridates himself had so fortified his constitution against poisons, that when he wanted to kill himself by poison none would produce any effect. In Celsus it contained thirty-five ingredients, Andromachus increased the number to seventy-five, and it still survives in the French Pharmacopœia, but reduced to sixty ingredients, among which we find a kind of clay, dried vipers, bread crumbs, gum-arabic, castor, opium, and a host of harmless herbs. It may be asked, What is the real state of our knowledge of antidotes? When a poison is administered, of course for a shorter or longer time it remains in the stomach before absorption into the system takes place. This may be almost instantaneous, as in the case of concentrated prussic acid, or it may take time, as when arsenic in the solid form is employed. Probably no poison can act unless it is dissolved either before administration or by the contents of the stomach. At this stage we may, in some cases, render the poison insoluble in the stomach, as bichloride of mercury by albumen, oxalic acid by a lime compound, arsenic by freshly precipitated oxide of iron, and then, by some powerful emetic, or by mechanical means, remove the injurious substance before it can become re-dissolved. So far we may be said to possess antidotes to many poisons, but this is not the sense in which the term is usually employed. An antidote, in the popular sense, is something which will counteract the action of the poison when it has entered the system in quantity sufficient,

if unchecked, to produce death ; and of such antidotes we possess indeed few, and those principally to poisons of vegetable origin. Morphia is to some extent an antidote for strychnine, and by the careful balancing of one poison against another life has sometimes been preserved. Strong coffee, and possibly caffeine, might in like manner neutralise the action of morphia. Curare has been suggested as an antidote for strychnine, but in Watt's *Dictionary* it is stated that it is ineffectual. And that is about the state of our knowledge.

2.—That formerly there were poisoners who could produce effects far in advance of anything known at present. Paris says, “Nor shall I consume the time of the reader by attempting to expose the absurdity of those fearful powers with which ignorance, terror, and imposture have invested certain poisons—a subtlety so extreme as to defeat the most skilful caution, and a virulence so unmanageable as to be capable of the most accurate graduation ; so that while the former attribute was believed to ensure their deadly operation, although exerted through the most secret and least suspicious medium, as that of gloves, tapers, or letters, the latter was said to enable the accomplished assassin to measure the allotted moments of his victim with the nicest precision, and to occasion his death at any period which might best answer the objects of the assassination.

“The abandonment of such notions may be considered as one among the many advantages which have arisen to medicine from the cultivation of phynology.”

So wrote Dr. Paris, in 1829, but how far are those expectations realised. I take up Miss Braddon's *Trail of the Serpent*, and find one character, speaking in presence of a chemist and mystery-man, says :—“A tender pressure of the traitor's hand, a flower or a ribbon given as the pledge of love, the leaves of a book hastily turned over with the tips of moistened fingers, people had such vulgar habits in those

days, and behold the gentleman died, and no one was any the wiser but the worms, with whose constitutions aqua tofana at second-hand may possibly have disagreed." And then the mystery-man, for one can find no other name for that wonderful being whom we meet in sensational novels, who is an astrologer, chemist, spiritualist, with a strong dash of the necromancer, who knows everybody's secrets, and sneers at the clever villain who is so shallow to his transcendent intellect; he says of himself, "Nothing more easy, madam; I have only to raise my hand, to wave a handkerchief medicated in the manner of those of the Borgias and Medicis used of old, before your face, to scatter a few grains of powder into that fire (N.B., the fire was in a grate with, we may presume, an ordinary draught) at your feet, to give you a book to read, a flower to smell, and you do not leave this room alive."

There is no doubt that it was thoroughly believed, in the days when this idea arose, that such wonderful powers were possessed by poisoners. John, King of Castile, was said to have been poisoned by a pair of boots prepared by a Turk; Henry IV. by gloves; Louis XIV., fearing a project to poison Philip V. of Spain, prohibited his opening letters or putting on gloves; Pope Clement VII. is said to have been poisoned by a taper; and, as a climax of absurdity, a priest is reported to have offered to destroy Queen Elizabeth by poisoning her saddle (Sir Edward Coke, in the trial of Sir John Hollis). Still, I do not think that we have any reason to believe that such wonderful knowledge of poisons was possessed in those days. The acquaintance of these poisoners with chemistry must have been remarkable if they could have so far exceeded anything known in these days; and there was no science of chemistry then. The alchemists worked entirely at random; they had no knowledge of the true nature of chemical compounds, or even of simple bodies. To

them the metals were not elementary, but compounds, which a slight change might convert into gold or silver, if only the means to bring about that change could be discovered. They knew that certain plants possessed poisonous properties, but they did not know how to isolate the poisonous principles; they distilled liquids in the hope of obtaining these, and merely destroyed them in the process. They had no means of obtaining pure materials to work with, for they had no way of ascertaining their purity when analysis was unknown, and every repetition of an operation was uncertain when it was a mere matter of chance whether the materials employed were the same. Our knowledge of minerals is far greater than theirs; instead of seven or eight metals, we know fifty; our knowledge of botany is far more extended than theirs; we can not only ascertain the poisonous nature of plants, like them, by experiment, but isolate the deadly alkaloid. We do not run the risk of neutralising the action of one body by another incompatible with it, or of destroying a compound by treatment which decomposes it; and if in these days we do not try experiments on human beings, a Vivisection Act shows that our physiologists have no particular compunction with regard to animals. Yet we cannot produce any of these wonderful effects; and, in the absence of indubitable proofs, we may fairly doubt the alleged facts. What were the poisons employed then? The *aqua tofana* was most probably, from the description of its effects, stripped of romantic details, a solution of arsenic in some alkaline liquid; the powder of succession is said to have been sugar of lead; and prussic acid, in a dilute form, was certainly known, obtained by the distillation of laurel leaves, or from bitter almonds. The true source of the success of these poisoners was the ignorance of chemistry which prevailed, not the knowledge of it; it was the impossibility of detecting the poison in the body of the victim, not the incredible subtlety of its nature;

and, with the discovery of analytical chemistry, with its power of detecting almost imponderable amounts of mineral bodies at least, secret and slow poisoning have passed away into the same limbo as the philosopher's stone, the elixir of life, and the universal alcahest. "Omne ignotum pro mirifico" is true with regard to this as well as other fabled powers of the ancients. To all this it may be added that the use of such volatile poisons as some of those spoken of, would have been as dangerous to the maker and user as to the intended victim; and one cannot repress a smile when we read of the glass mask, which is one of the stock properties of the novelists' poisoner, when we try to imagine how that could prevent the poisonous vapour from finding its way into the lungs of the poisoner, mixed with the air which must have been furnished in some manner to prevent him from dying of suffocation.

3.—That slow poisoning is possible, *i.e.*, that a poison can be administered so as to produce its effects only after the lapse of days, and then to kill. I give this definition to distinguish this form of slow poisoning from that which certainly is possible, that resulting from the successive administration of small doses of a poisonous substance. That the former was believed in, even by scientific men, two hundred years ago, is evident from a list of questions drawn up by the Royal Society shortly after its institution, to be used by travellers in India and China, one of which was: "Whether the Indians can so prepare that stupefying herb, *datura*, that they make it be several days, months, or years, according as they will have it, in a man's body, without doing him any hurt, and, at the end, kill, without missing half-an-hour's time." Some romancing traveller must have set this notion afloat, and it is just as much to be believed as the tales of Italian poisoners.

In opposition to all these fables, I quote Dr. Taylor, who

states that in general all poisons manifest their effects in not more than two hours. Under certain circumstances, partly depending on the form in which the poison is administered, as, for example, arsenic in coarse powder, or the state of the stomach, as being full, as long as ten hours may elapse ; but this, he thinks, is the maximum time. The only instances which I have met with at all resembling slow poisoning are two, in which two assistants of Dr. Odling, who had been engaged in experimenting on a new organic metallic body, mercuric methide, were the sufferers. One had worked with it for three months, painful symptoms of mercurial poisoning showed themselves, and in eleven days from admission to the hospital he died, becoming maniacal before death. The other had only worked with the substance for a fortnight in January ; in March, 1865, he was admitted to the hospital, became gradually worse, and in July was idiotic, recognised no one, was deaf, and unable to speak any words. He remained in the same state until April 7, 1866, and then died.

Nitro-benzole, in experiments on animals, has been found occasionally to act after three or four days have passed without sign of injury, death resulting sometimes in nine days after administration. The known cases in human beings were characterised by speedy action, and fatal results in a short time.

In some cases where serious local injury has been caused by powerful corrosive bodies, as strong acids and alkalis, death sometimes results, after a considerable time, in consequence of what we may call the mechanical effects ; but these bodies are scarcely what we understand in a general way by poisons.

4.—That there is a chemical means of distinguishing between poisonous and non-poisonous bodies taken generally. This fallacy is the one which has particularly come under

my notice. Persons continually bring me animals, articles of food, medicine, &c., to analyse, and when their curiosity to know whether they or their animals are being poisoned is considerably diminished by the number of guineas asked for the detection of the poison, they regularly say, "Well, can you not say whether there is something poisonous, without specifying exactly what it is?" And when I assure them that chemistry knows no test to distinguish poisonous properties, they go away with, I fear, the firm conviction that the chemist of to-day is a humbug, in no way to be compared with his ancient ancestor in the business. Yet, if we consider that poisons may be metallic or non-metallic; acid, alkaline, or neutral; mineral, vegetable, or animal; elementary or compound; that in many cases the body may be a poison or wholesome, according to the quantity taken, as common salt or nitre, it will, I hope, be plain that no test can infallibly detect this poisonous property, and tests for poisons generally do not exist; and that, when no indications are given, the only plan is to look for every known poison individually. To this fallacy is naturally related the next.

5.—That poisons are of easy detection. Here I must enter a strong protest against the novelist. In novels the doctor usually, with the aid of chemicals, sometimes drawn from the kitchen, or, at all events, contained in a small laboratory which he carries about with him, forthwith pronounces the name of the poison contained in the draught.

I will give two instances from *Monte Christo*. I translate from the original. The poison used is supposed to be brucine, from its bitter taste, and, I suppose, the effects produced; it was given in lemonade. M. d'Avrigny speaks of having sent into the kitchen for some syrup of violets, which he has put into a glass. "The doctor poured slowly some drops of lemonade from the carafe into the cup, and immediately a cloud was seen to form at the bottom of the

cup; this cloud took at first a blue shade, then from sapphire it passed to opal, and from opal to emerald.

“Arrived at this colour, it fixed itself so to say; the experiment left no doubt.

“‘The unhappy Barrois has been poisoned with false Angostura bark, or St. Ignatius’ bean,’ said d’Avrigny; ‘now I will answer for it before men and before God.’”

And, if he could have got the result so pictorially described, it might have been due to carbonate of soda, only he could not. Lemonade is an acid drink in France as in England, and the reaction by which syrup of violets becomes green is common to all bodies with an alkaline reaction. Brucine, being an alkaloid, would give the reaction if it were free, but in an acid liquid nothing would happen.

Then, when the poison was changed for a narcotic not named, but clearly morphia is meant, we read, “Then he ran to one of the cupboards in Valentine’s room, a cupboard transformed into a druggist’s store, and drawing from its little silver case a bottle of nitric acid, he let a few drops fall into the opal liquor, which was changed at once into half-a-glass of vermilion blood-red (*sang vermeil*).”

Here it is erroneously supposed that because strong nitric acid upon dry morphia will produce a red colour, it would do the same in a solution in which the morphia was in a highly diluted state, and in which, as it was a beverage prepared by the doctor, we may assume that other organic substances were present, whereas no result at all would follow.

The truth is, that in almost all cases, and especially in those in which organic poisons are used, the poisonous substance must be isolated from all other bodies with which it has been mixed, and obtained in a pure state before the tests which characterise it can be applied. This, in many cases, is a tedious and difficult operation, requiring the appliances of a laboratory and the skill of a practised toxicologist. That these

remarks are not unnecessary, is proved by a case of which I read in the *Times* a short time since. The case was evidently one of opium poisoning, but, unless the case was incorrectly reported, the doctor who tested for the poison did so in the contents of the stomach without any preparation. If so, I have no hesitation in saying that the tests were valueless.

6.—That chemists can in all cases detect the poison which has been employed.

This is true when mineral poisons have been employed, although phosphorus must be looked for before it has become oxidised, and prussic acid, in small doses, in a few days is lost by volatilisation. But when we come to organic poisons, the number of those which admit of certain chemical detection in the body, when death has been caused by doses not much larger than sufficient to produce death, is very small. Strychnine is fortunately one of these; but this body is exceptional among organic bodies. It appears to be little effected by the fluids of the body; it even withstands the action of strong sulphuric acid, assisted by heat, and its reactions are numerous and delicate. This is not the case with many other alkaloids. They are generally complex bodies given to decompose; it is probable that many of them undergo molecular change in producing their deadly effect; and, to take a particular instance, morphia is one of the most frequently employed organic poisons, and yet I think there is satisfactory evidence that when employed in small quantities it is hopeless to look for chemical evidence of its presence.

The tests for alkaloids are for the most part colour tests, under the action of concentrated acids and powerful chemical agents, and the removal of all extraneous organic matter is most difficult to effect, and is yet absolutely necessary. Then, for some of these bodies, I think I shall be unchallenged when I say that there are no tests known on which a con-

scientific chemist would risk the life of a fellow-creature, and his own reputation.

Another danger in regard to the detection of alkaloidal poisons has recently been pointed out by Moriggia and Battistini (abstract in *Journal of Chemical Society*), who have shown that, in putrefying animal matter, alkaloids are formed similar in physiological effect to atropine, and as poisonous.

F. Selmi, from experiments made on the putrefied viscera of an animal poisoned by atropine, and on the alkaloids generated by the putrefactive process in the viscera themselves, finds that one of those formed in the latter case, and which may be extracted by the use of analytic alcohol, closely resembles atropine in its action on the animal organism.

Some experiments, made by Dr. F. C. Calvert, also showed the formation of alkaloids in decomposed meat.

7.—That some poisons have the effect of producing external marks on the body, such as blotches or spots. Tacitus says that the body of Britannicus became black from the effect of poison administered by Nero. The symptoms of death were that he was seized with an epileptic fit, and died suddenly. Captain Donellan was accused, in 1791, of poisoning Sir Theodosius Boughton, his wife's brother. Among other evidence, it was stated that when the body was disinterred, it was of the colour of a pickled walnut. In both these cases, death was immediate, and in the latter, laurel water was said to be the cause of death. I do not find, in looking over Taylor's *Medical Jurisprudence*, and other toxicological works, that any known poison manifests itself in this way, and although there is evidence that prussic acid will produce occasionally lividity of the countenance, owing to congestion, this is not always the case: Taylor says, "The post-mortem appearances are very slight," and in another place, speaking of the body of a person poisoned with a small

dose, "it had very much the appearance of the body of a person who had died from asphyxia." Speaking generally, he says, "From this general summary of the appearances, it will be perceived that there is but little to be derived from an inspection of the body at all characteristic of the cause of death."

The description of the effect of hemlock (?), in *Hamlet*, is well known :—

" Sleeping within my orchard,
 My custom always of the afternoon,
 Upon my secure hour thy uncle stole,
 With juice of cursed hebenon in a vial,
 And in the porches of mine ears did pour
 The leperous distilment ; whose effect
 Holds such an enmity with blood of man,
 That, swift as quicksilver, it courses through
 The natural gates and alleys of the body ;
 And, with a sudden vigour, it doth posset
 And curd, like eager droppings into milk,
 The thin and wholesome blood : so did it mine ;
 And a most instant tetter bark'd about,
 Most lazar-like, with vile and loathsome crust,
 All my smooth body." Act i., Scene 5.

In all cases where such results follow, I think, in these days, there would not be much doubt that disease, not poison, was the cause of death. In how many cases in history, where this was considered evidence, the innocent have suffered, or their characters have been branded with the accusation of this fearful crime, will never be known, but all students will recall many cases.

8.—" That narcotic poisons are known which, in carefully arranged dose, will cause suspension of the vital functions, so as to deceive even a medical man into a belief that death has occurred, and that, after a certain time, the person will revive without injury."

Abundance of instances of this belief may be met with in popular literature. In *Romeo and Juliet* :—

“Take thou this phial, being then in bed,
 And this distilled liquor drink thou off,
 When, presently, through all thy veins shall run
 A cold and drowsy humour, which shall seize
 Each vital spirit ; for no pulse shall keep
 Its natural progress, but surcease to beat ;
 No warmth, no breath, shall testify thou liv'st ;
 The roses in thy lips and cheeks shall fade
 To paly ashes ; thy eyes' windows fall,
 Like death, when he shuts up the day of life ;
 Each part, deprived of supple government,
 Shall, stiff and stark and cold, appear like death :
 And in this borrow'd likeness of shrunk death
 Thou shalt remain full two and forty hours,
 And then awake as from a pleasant sleep.” Act iv., Scene 1.

Miss Braddon, in the book before quoted from : “The potion given her by Blurosset was a very powerful opiate, which had produced a sleep resembling death in all its outward symptoms.”

Dumas, in *Monte Christo*, after the count has given Valentine a pill, of the size of a pea, of haschisch, describes the effect produced : “The young girl no longer breathed, her teeth, half separated, did not let any atom of that breath escape which reveals life ; her whitening lips had ceased to quiver ; her eyes bathed in a violet vapour, which seemed to have filtered under the skin ; and her long lashes streaked a skin already dull as wax.” “Her heart was silent and frozen.”

This was supposed to last more than thirty-six hours, as the narcotic was taken at midnight ; the body remained all the next day, and was taken to Père-la-Chaise at twelve o'clock the day after. No details are given of the return

to consciousness, but that no ill effects followed we gather from subsequent events.

Now, that nothing of all this is possible I think we may rest assured. For life to continue without oxidation or movement of the blood is inconceivable, without a miracle.

The stoppage of the heart's action is one of the surest signs of death. A French commission, including MM. Duneril, Magendie, Andral, Serres, and Rayer, awarded the Manni Prize to M. Bouchut, for researches showing that in cases of apparent death from asphyxia or syncope there was one distinguishing symptom, the continuance of the pulsation of the heart.

I have not been able to meet in my reading with any narcotic which would produce anything like the effects mentioned. If narcotics are given in large doses, stertorous breathing appears to be one of the general symptoms, when the narcotism is so complete that the patient cannot be aroused.

I have thus brought before you the present state of our knowledge with regard to these popular errors about poisons. I do not think that it is amiss fairly and fully to confess our ignorance of many points in the detection of poisons, as I do not fear that any practical injury can result from such candour. The poisons which the chemist cannot detect are those which none but the scientific chemist can procure, and their physiological effects are sufficiently well marked to leave little doubt with regard to their use.

I have, therefore, endeavoured to elicit the truth irrespective of consequences, and in this I think I best fulfil the aim and interests of this Society.

ON THE SUFFIX *-STER*.

By JOSEPH BOULT.

IN an instructive communication to this Society last Session, on *Repetition and Reduplication in Language*, Mr. Newby Hetherington observes that, in Old English, *-ster* "was a common ending to mark the feminine, and we still retain it with part of its old force in *spinster*. Up to the end of the thirteenth century, *-ster* was a characteristic sign of the feminine gender, and by its means new feminines could always be formed from the masculine, e.g., *baccestre*, *hearpestre*, and a very curious form, *bellingestre*. In the fourteenth century, we find the suffix *-ster* giving place to the Norman-French *-ess*, and there is consequently a want of uniformity in the employment of this termination. Robert of Brunne, 1325, uses *sangster* as masculine; and eventually *-ster* came to denote the agent or doer of an action, though a good number of nouns with this suffix are to be found as feminines late in the fifteenth century. Now when *-ster* was losing its original power, the meaning of the word was emphasised by adding the Romance suffix *-ess*, and such new words were formed as *songstress* and *seamstress*, which are etymologically double feminines."*

If Mr. Hetherington errs in these observations, it is in good company, and he may justify himself by many venerable precedents; nevertheless, there appear to me grounds for assuming that he and those who concur in the views expressed do err; and I will submit to your judgment the base of my opinions.

* *Proceedings Literary and Philosophical Society*, No. xxx. 1875-6, p. 132.

First, for some authorities anterior to the end of the thirteenth century. In an Anglo-Saxon *Vocabulary*, ascribed to the eleventh century, *baecestre* is the gloss for *pistor*; and in a semi-Saxon *Vocabulary* of the twelfth century is the same gloss, varied in the spelling, *bakestre*. John de Garlande, in the first half of the thirteenth century, has a similar gloss, spelt *baxtres*.*

It would appear, then, that so far as bakers were concerned the suffix *-ster* had no exclusively feminine application as early as the eleventh century.

An English *Vocabulary* of the fifteenth century has *hāec brasiatrix* brewster, and *hic pistor* bacster; a *Nominale* of the same period gives the word webster as common to both sexes, *hic textor* and *hec textrix*; and enumerates among feminine occupations those of kempster, sewster, barbor, baxter, brewster, hukster, and brawdster, or embroiderer. In the same *Nominale*, *hec citharista* is glossed harper; whilst in the supplement to Alfric's *Vocabulary*, tenth or eleventh century, it is rendered hearpestre, *citharedus* being harper.

In *Prompt Parv.*, 1440, there is not any exclusive application of the suffix *-ster* to feminines.

I am unable to find more than such partial applications as those referred to; and I doubt if they were more than temporary or local, just as the several functions were discharged by either sex. A simple citation of the words having that suffix will, I think, be accepted as throwing grave doubt upon the statement that it had ever an exclusively feminine significance. From the following list are excluded, not only such words as aster, sister, and jester, but words like alabaster and balluster; derivatives from Greek or Latin; and also such local and personal names as Collister, Hobbi-

* *A Volume of Vocabularyes*, edited by Thomas Wright, M.A., &c., 1857. Privately printed at the expense of Joseph Mayer, Esq., F.S.A.

ster, Isbister, Lydster, Ulster, and Inkster; the number of exceptions indicating a want of precision in the canon adopted by Mr. Hetherington, in itself discrediting.

AistreA house ; a fire-place ; a street ; a circumstance.

“ it was not left,
Tyl I hadde alle the gardyn bene,
In the estres which men might sene.”

The Romaunt of the Rose.

AlchemisterAn alchemist.

Arcister.....Arcista ; dioleticus.

BackstersFlat boards strapped to the feet for walking over a loose beach.

Bagster? A bag or breeches maker.

BandsterOne who binds sheaves after reapers.

Bangister }
Bangster } Swipes ; strength of hand ; also to cheat.

BanisterA bath-keeper.

BannisterA person paid to remove to another jurisdiction.

BarristerA pleader in law.

BasterA heavy blow.

BaxterA baker.

Bellingestere A bellringer.

Bleykester.....A bleacher.

BoisterA rough fellow.

BolsterA headrest.

BrewsterA brewer.

BroadsterAn embroiderer.

CanisterA metallic vessel.

ChidesterA scold.

ChoristerA member of a choir.

- Costermonger*A dealer in vegetables.
DabsterAn expert.
DeemsterAn arbitrator or assessor.
Dexter? Digester, or dykester ; a ditcher.
**Drugster*A druggist.
DrysterA dryer (*siccatrix*).
DybynisterA theologian.
FaldistorThe highest seat of a bishop, enclosed
with a lattice.
Fewster..... A feuar or feoffee.
FoisterA pickpocket.
FopsterA cutpurse.
FruitstereA fruit dealer.
GamesterA gambler.
GanisterBeds in the coal measures.
Gunster.....One who shoots with a gun.
Hackster A butcher, a cut-throat.
HalsterA swaggerer, a ruffian ; one who draws a
barge.
HarpestreA harper.
HobbesterA dancer ; a kind of fish. ? A lobster.
Hoggastere }
Hogsteer..... } A boar of three years.
Holster..... }
..... } A case for horse pistols.
Hoppestre..A dancer.
HucksterA petty dealer ; *caupones*, *victillarius*,
auctionatrix.
HuesterA dyer.
JousterA retailer of fish.
KempsterA comber.
Land-metsterA measurer of land.
LasterThe flowing tide.
LegesterA lawyer.

* *Druggeria*, a place of drugs, or drugsters' shops, &c.

- Leister*A salmon spear.
LikestreA laundress; *linctrix*.
ListerOne who reads some part of the church service.
LibsterA dyer.
LobsterA crustacean; a stoat.
LoppestreA young sole.
MaltsterA maker of malt.
MinsterA monastery.
OlsterA senior.
OrganisterAn organist.
OysterA mollusc.
PalmisterA diviner from the hand-palm.
PalsterA pilgrim's staff.
Plaister.....A surface application.
PlumstereA plumber.
PoetasterA versifyer.
PresterA priest.
PrigsterA thief.
Punster.....A player on words.
Radchenistre? An arbitrator.
RegisterA record.
RhymesterA maker of rhymes.
RoadsterA traveller's horse.
RoisterA riotous person.
RoysterAn inventory.
SalsterA saltmaker.
Sawistar ... A sawyer.
SeamsterA stitcher.
ShepsterA stitcher.
ShoosterA stitcher.
SegsterA sexton.
Seister (*shêter*) ...A javelin-thrower; *jaculator*.
ShepsterA sheep-shearer.

- **Shipster*A sailor or shipwright.
SongsterA vocalist.
SpinsterAn unmarried female.
Tapster.....An ale-drawer. .

Falstaff says :—“ A tapster is a good trade ; an old cloak makes a new jerkin ; a withered serving-man a fresh tapster.”

- Teamster*A carter or waggoner.
ThaxterA thatcher.
Throwster.....A silk-weaver.
TilsterA magician.
TricksterA slippery fellow.
Tumbestere? A dancer.
TymbesterreA juggler with a *timbre* ; a metal basin.

“ The tymbres up ful sotilly
 They caste, and hente fulle ofte
 Upon a finger fair and softe,
 That they failide never mo.”

—*The Romaunt of the Rose*.

Upholdere..... A dealer in smallwares.
 (? *Upholster*)

Note.—Upholstar is glossed by Palsgrave *frippier* ; *i.e.*, a dealer in old clothes.

- Wafestere*A maker of wafers ; the unleavened cakes
 of the Eucharist.
WaschestreA laundress—*lotrix*.
WebsterA weaver ; a knitter.
WhipsterA youth ; a bleacher.
WoolsterA woolstapler.
 ? A woolwright, *i.e.*, a woollen-weaver.
WoosterA suitor, a wooer.

* *Shipster* is A.-S. *scip-styra*, a ship steerer or pilot.—Lower's *English Surnames*. To me the word appears to be K. *scib-eistear*, or primarily *sgioib-eistear* ; unless it is allied to *shepster*, a sewer ; in which case both words may denote a sailmaker.

WhysterA bleacher.

YdolasterAn idolater.

YoungsterA junior.

To the above may be added *smere-mangestere*, which occurs in the *Domes* of Æthelred, *De Inst Lund*, and is glossed by Thorpe, "A woman who deals in butter." The passage in which it occurs relates to the toll-giving at Billingsgate, and is as follows:—"Smeremangestre, que mangonant in caseo et butiro xiv. diebus ante Natale Domini unum den, et septem diebus post Natale unum alium." That is, smeremangesters who deal in butter and cheese are to pay the tolls mentioned; but other smeremangesters who did not deal in those two commodities were exempt, such as dealers in oil, tallow, grease; from K. *smear*, grease, tallow; monger is manifestly K. *mangaire*, a dealer, a peddler, a jobber—G. *sailmhangaire*. There are also several synonyms for a bleacher in *Prompt Parv.*, namely, bleyster, plekstare, qwystare, and whyster; probably the last two should be qwytstare and whytster; and that all denote bleachers.

Some of the words quoted above have, no doubt, fallen into disuse, whilst others are comparatively modern. The Poet Laureate has recently formed a word on the like model, in his tragedy of *Harold*, where the hero says:—

"The simple, silent, selfless man
Is worth a world of *tonquesters*."

Shakespeare possibly exercised a similar license when, in the *Merry Wives of Windsor*, he wrote:—

"Against such lewdsters, and their lechery,
Those that betray them do no treachery;"

and it may be inferred that some other words have a like origin.

Reverting to the list of words, it is clear that many of them could never have had a feminine signification, though unquestionably of ancient date.

The meaning of the word *radchenistre* is uncertain, but no one ever suggested it was feminine; ladies, ere long, may be called to the bar, but hitherto none have been called barristers, though *Portia* and Lady William Russell are illustrious exceptions to usage.

Chorister, originally, would doubtless be masculine, considering how jealous the Papal Church has ever been of the intrusion of females into the choir.

The ruffianly *bangster* and *hackster*, and the useful *sawistar*, are essentially unfeminine; while the ringing of church bells, and the office of sexton, would scarcely be permitted to women. Other words were, no doubt, employed indifferently, as *baxter*, *brewster*, *huckster*, *kempster*, and *seamster*; whilst others may be regarded as neuter, like *canister*, *bolster*, *holster*, *lobster*, *oyster*, and *roadster*. Thus it would appear that to define *-estre* or *-istre* as the feminine termination of nouns of action, same as the Latin *-ix* and English *-ess*, to quote the definition of Bosworth, is very fallacious; and that definition is no doubt due to the remarkable supposition that modern English speech is essentially Teutonic; the favourite hypothesis of those whom one of the most eminent living philologists dubs *saxo-maniacs*.

So far as my inquiry has proceeded, it appears to me almost indisputable that the English are essentially Keltic, in name, race, and language, and that the continuity of English history dates from a period earlier than the incursions of Julius Cæsar. That Keltic essence has doubtless been greatly modified by continuous immigration from the continent, which, as we have evidence, preceded Cæsar, and has not ceased even to this day; whilst

those who represent the indigenous people, still continue that westward march which seems inherent in the race.

If the suffix *-ster* be not derived from that stage of development of our mother-tongue aptly termed Anglo-Sacsan, perhaps the root may be found in an earlier growth. It appears to me that it, and some of the earliest words to which it is added, are Keltic, and are derived from the speech of those who abided in Britain when the Romans withdrew, and still live in the English-speaking races of the present day. The Irish word *eistear*, signifies an art, a trade; and this meaning is implied in the suffix *-ster*. A barrister follows the art or pursuit of the bar; the baxter, that of baking; the brewster, of brewing; the webster, of weaving; and so of the rest of the list. It is true the suffix is not found in modern Irish, in which the place is usually supplied by *-aire*, or some other equivalent for the modern English *-er*, and the Latin *-or*. Although the crude forms of baker, brewer, webster, and other words are to be found in Irish, the words most generally used appear to be of wholly different character; a change doubtless due to the incidents of the long interval of time since that branch of the race separated from those who remained in England, and submitted to the logic of circumstances.

In Irish are words *bacailine*, I bake; *bacail*, baking; *baculta*, baked; and *bacala*, a bakehouse; adding the suffix to the root of those words produces *bac-easter*, the baking art; the change thence to baxter may be traced orthographically almost letter for letter. The application of the name of the art to the person who practises the art is probably due to some misconception on the part of foreign immigrants, similar to that which originated the mistake as to *-ster* or *-estre* being feminine.

The root of the word to brew means both to boil and to bake; *bruith* denotes flesh, broth, boiling, smelting, and

baking; and the verbs, adjectives, and nouns derived from it are equally varied; whilst the noun *bruin* is a large pot, or brewing-pan, and *bruitheoir*, a brewer. Of the original variety in the signification of the root are survivals in *broth*, *brew*, and *brewis*, the last a word still in use in Lancashire and Yorkshire, glossed oatcake or bread, toasted, and soaked in broth or stew. Mr. Gaskell is quoted, as explaining that, in Lancashire, bread soaked in broth, or in the fat that drips from meat when being roasted, is known as *brewis*. A writer in the reign of Edward VI. refers to "*brewess* made with bread and fat meat."—*Lect. Lanc. Dialect*.* So far, however, from *brewis* being peculiar to Lancashire, it appears in Pardon's edition of Dyche's *Dictionary*, 1735, as *brewess* or *brewiss*, biscuits, or crusts of bread, soaked in the liquor and fat of boiling meat; and *broth* is described as the liquor in which flesh or pulse is boiled.

In Scotland, the epithet *browster-wife* is applied to female ale-sellers, especially in markets, plainly showing that *browster* alone may be masculine.

The word *webster*, in its different orthography, has reference to the processes of knitting and weaving, implying that the latter is a development of the former. The verbal root is doubtless K. *fighim*, I weave, plait, twist; from the present participle of which, weaving, is obtained *fighad*, pronounced weoo, to which annexing *fear* (Lat. *vir*), a man, is formed the modern English word *weaver*, literally weaving-man, in which the suppressed *a* is a survival from the original form. The Irish for weaver is *figheadoir*. When the name of the artisan became *weaver*, another series of words would be formed, as the verb to weave, weaving, weft; the latter the crisp sound of weaved, like left for leaved, past for

* *A Glossary of the Lancashire Dialect*, by John H. Nodal and George Milner. Part I. Publications of the Manchester Literary Club. It is to be regretted that the contributors to this valuable work do not carry their etymological inquiry beyond the Anglo-Saxan period.

passed, and wolf for wolve. Dropping the final t in weft, by mutation, the letter 'f' becomes 'b,' forming web; thence webber and webeistear, the first the artisan, the latter the art, the substitution of webister for webber, arising, as suggested, from misconception or metaphorically.

The introduction of the term weaving-man, *i.e.*, weaver, appears to date from the time when knitting-needles were partially superseded by the loom. Previously, no doubt, knitting had usually been woman's work, as it is now; but the application of the loom requiring more physical strength than usually belongs to the gentler sex, the assistance of the male creature was requisite, and the weaving-man became a recognised institution. So with baking and brewing; when they became trades for supplying more than one household, the burden was taken up by men, who thus sought to show their devotion to the weaker vessel. Home-brewed ale and household bread, when genuine, are usually brewed and baked by women, who also retain their pre-eminent position of queen of the teapot, distilling the fragrant cup which cheers, but does not inebriate.

Mr. Lower, in *English Surnames*, glosses whitster as fuller, instead of bleacher, but he has overlooked Mistress Ford's use of the word, when she ordered her men with the buck-basket to "Carry it among the whitsters in Datchetmead" (*Merry Wives of Windsor*), speaking in whiting time, which appears to fix its meaning as bleacher. Assuming that *-ster* is feminine, Mr. Lower quotes, with concurrence, Mr. Poulson's explanation in *Beverlac*, of the manner in which those names of feminine employments could become hereditary surnames: "When men began to invade those departments of industry by which women used to earn an honest livelihood, they retained the feminine appellations for some time, as men mid-wives and men milliners do now."

Shakespere uses the term woman-tailor. Is it to be supposed that the fair sex, in a body, ever supplanted men in that occupation ?

It would weary your patience to quote glosses of all the words, or to enter into their analysis ; but there are a few which appear to require especial attention ; and they testify how much historic illustration may be drawn from judicious philology.

The word prester for priest, which survives in Prester John's title, is suggestive of the primary function of a priest's office. Assuming that the final syllable represents the suffix *-ster*, and that *K. eistear*, a trade or calling, whence is the first part of the word derived ? It is possible that the letter *i* in the word, as now used, may be a survival, and, with this clue, it seems probable that the word was formerly *breitheistear*,* the prefix in which, *breith*, signifies penance ; thus the whole word would designate the calling or occupation of doing penance. But the proper signification of *breith*, is judge, judgment, doom, a compact ; also a bearing, a bringing forth ; and it was used in combination with the word *aithrighe*, signifying penance and repentance, to denote a special penance. In colloquial use, it appears *aithrighe* was dropped, and the priest bore a title which, in its full explicitness, denoted the trade of bearing vicarious penance ; thus he was really a bedesman, of superior degree, but of the same order as Edie Ochiltree, the Blue-gown.

The word radchenistre, occurs in *Domesday* ; and, I think, is seldom, if ever, met with elsewhere. It is found only in the counties of Gloucester, Wilts, Hereford, Worcester, and Salop ; and the designation of Radmann is found in the three latter counties, and also in Cheshire. It appears to me probable that the terms are synonymous, or nearly so. I have

* When sounded as a disyllable the aspirated *t* would be suppressed by the following *s* ; the substitution of *p* for *b* is very common.

attempted to show* that the Radmanni discharged functions something resembling those of the Roman judices; that the office and name are found at this day in Sweden; that they are men possessing a given position in the community, and were, therefore, eligible or liable to be summoned for the performance of specified duties, that is, to assist in the administration of the law; that the word radmann signified one specially appointed to assist in the adjustment of differences, by explaining local usages; and, it appears to me, that radchenistre resembles it in the first two syllables; they representing *K. radh-ceann*; the termination *-istre* being a modification of *eistear*. Now, assuming that those who bore the designations were arbitrators, and remembering how difficult it is for arbitrators to avoid becoming advocates for the parties by whom they are selected, it seems to be not improbable that the judices, radmanni and radchenistri, were that order of functionaries who are now represented by counsel; who, driven from the bench, on which their presence was unwelcome, since they strove for victory rather than law, took refuge at the bar, and became barrasters or barristers, the most eminent among them being admitted within the bar, but below the bench. Thence their passionate appeals or fierce denunciations have been tolerated, even admired, since those who utter them no longer besmirch the purity of the ermine, to which they are still permitted to aspire.

Doubtless someone will protest this suggestion is fallacious, since a barrister who had kept his terms was styled an utter barrister, which means an outer barrister, because, though able to plead, he was not yet admitted within the bar. It seems to me that the fallacy is in the supposition that the word utter means outer, or is another mode of spelling the same word. Utter appears to be allied to entire, as in the

* *Notes on Early Social Grades in England*. p. 26; privately printed, 1876.

phrases "utter absurdity," "uttermost degree," "utterly impracticable;" and, therefore, the utter barrister is one who has satisfied all the preliminaries to holding a brief.

The word *utter* and its compounds presents an example of the very unsatisfactory shifts to which philologists are driven who assume that the Anglo-Saxsan is the earliest form of the English language, and neglect the Keltic speech of the indigenous angle or ongle, French *anglais*, K. *angeilleis*. It is difficult to associate the ideas of perfection and exterior; and yet, if *utter* is a form of *outer*, the association must exist in some form. *Utmost*, which represents S. *utmæst*, *utmost*, is obviously a contraction of *uttermost*; and, signifying as it does, adjectively, extreme, or in the highest degree, and, substantively, the most that can be, the greatest power, appears far removed from mere externality. *Utter* appears to me allied to K. *uachdar*, the top, the summit, W. *uchder*; thence *uachdarach* and *uachdaraighe*, uppermost, highest; and *uachdaran*, a governor, ruler, superior. Correlative with these words are *ughdarash*, authoritative; *ughdarach* and *ughdaras*, authority, dynasty; *ughdarasach* and *ughdargha*, authentic; and the verb *ughdarasaine*, I authorise. The primitive of this series, *ughdar*, is glossed by O'Reilly, author; but, from the derivatives, it would seem also to denote one who gives or possesses authority, and may be accepted as the root of *utter*, as applied to an apprentice who was authorised to practise at the bar. So the person who, in legal phraseology, utters a document or a coin, assumes for it an authority which may or may not be valid; and people who utter their opinions give them authorised expression. The looser applications of the word and its compounds are among the incidents common to all words and phrases.

The weird pursuit of alchemy, after holding the intelligence of the civilised world under its spell for more than a thousand years, passed away, leaving its more robust twin-

sister, chemistry, to enjoy the fruit of their mutual toil. It seems strange that the received etymology of those names, alchemy and chemistry, should be so unsatisfactory as to suggest that their origin is as occult as that of the philosopher's stone itself. The name of chemistry, like the science itself, is, of course, congenital, and allied to the more visionary pursuit—alchemy.

While all glossarists are willing to accept an Arabic origin for the prefix *al-*, the body of the word is a subject of contention, some asserting that it is of Greek origin, signifying juice or melting, or rendering savoury; others, that it is Oriental, and means black; and others, again, that it is the proper name for Egypt, and signifies the science of the Egyptians. Dr. Latham* concludes his observations by saying: "How far the origin of the word was unknown in Johnson's time may be seen from the extracts. Nor is it absolutely beyond the range of discussion even at the present time; the most that can be said in favour of its derivation from the native name of Egypt being that the early history of the science favours it."

Under these circumstances it may be allowable to offer further suggestions. One of the earliest alchemists whose works are extant, is Geber, an Arabian physician, who lived in the seventh century; but some doubt has been cast on the genuineness of the works ascribed to him. Assuming that he was the author, it would appear that the pursuit of the philosopher's stone must have engrossed attention for a long period preceding his labours; he is said to have described and depicted various furnaces, crucibles, alembics, and other useful chemical apparatus, of which it is suggested he was probably the inventor; and he treats of distillation, sublimation, calcination, and various other chemical operations.†

* Dict. in verb. *chemistry*.

† *Penny Cyclopaedia*, Art. Alchemy.

Though the tradition which associates alchemy with Trimegistus is as unworthy of acceptance as the etymology which derives the name of alchemy from the native name of Egypt, still, such ideas seem indicative of great antiquity, and imply that the subject was studied long before Geber and the seventh century. It is not impossible, then, that it was known to the Romans, and may have been introduced into these islands during the Roman sway.

I have already suggested that during the period which succeeded the departure of that people, when the whole Continent was convulsed, Britain, like Arabia, was a home for intellectual cultivation, a shrine for the relics of a glorious civilisation.* Certain it is, that when Charlemagne, in the ninth century, desired to advance the mental culture of his people, he sought help among the Angles of Northumbria. Pretty strong evidence that Britain had not relapsed into barbarism, whatever bitter ecclesiastical partisans may have said. So firmly attached were the Britanni, and especially the Angles, to the gifts bestowed and left by the Romans, that the repeated irruptions of the less civilised Sacsans, and the uncivilised Danes and Norse, were unable wholly to destroy the fruits, however successful they might be in marring their perfect growth.

Among the intellectual treasures which survived the departure of the Romans, and the incursions of barbarians, it seems not improbable that alchemy and chemistry would remain, receiving a vernacular designation, which might abide with them through several of the countries to which they were restored from Britain.

The word alchemister is used by Chaucer, in his *Canon Yeoman's Tale*; and, as before suggested, the termination *-ister* is probably Keltic. That being assumed, it is reasonable to suppose that the remainder of the word is also Keltic.

* *Pre-Roman Civilisation in Britain.*

Doubtless, many hybrid words are to be found, but they are exceptional, and always suspicious; and the combination of the Arabic *al*, the, with the ancient name of Egypt, *Cham*, or with the Byzantine Greek words *χημεία* or *χυμος*, appears highly questionable. But the Irish furnishes roots for both the principal syllables; and they appear to harmonise perfectly with the little which is known of the history of alchemy and chemistry. In *K. al*, a stone, and *caomha*, skill, knowledge, is that pithy definition in which the Keltic speech excels; the compound indicating that search for the philosopher's stone which taxed the knowledge and resources of the most skilful adepts; whilst those who, mayhap, despised that visionary pursuit, by dropping the first syllable, retained testimony to their honourable and skilful search for knowledge. The pronunciation of *caomha* presents an apparent difficulty, but that, I think, would vanish through coalescence with the suffix *-ister*, or, more correctly, *-eistear*. As the suffix *-ist* is found not only as a contraction of *-ister*, as in organist for organister, harpist for harpestre, and also in words from the Greek, as in sophist, the same termination in alchemist and chemist left the apparent origin of those words very inconsistent and very doubtful. The Welsh for chemist, *fferyll*, also denotes a metallurgist; and another form of the word, *fferyllt*, signifies a metallist, an artizan; whilst the Gaelic, *seorsa tealsanach a bhitas ag obair le teine*, describes a sort of philosopher who works with fire. These designations seem to point to a period when chemistry was metallurgy, and had not advanced beyond the discovery of fluxes, and the assaying of metals; operations of the first importance in Britain, whose chief wealth has ever been metallic, and whose very name indicates her productiveness in tin. Thus, then, additional probability is given to the derivation assigned to the word alchemist, save that its original meaning may have been the practice of rock-science,

rather than merely that of stone-science, for the prefix *al-* may be interpreted either rock or stone. The word *alcamyne*, glossed by Wright* as a mixed metal, an alchymical term, is not inconsistent with these suggestions. In passing, notice may be given to the word *metal*, as an example of the epithet given in contempt becoming a title of honour. Of course the word is to be found in Latin, and therefore it is possible that the English have derived it thence; but how did the Romans acquire the word? It seems to me that philologists, and especially lexicographers, are too prone to adopt the first analogue as the origin of the English form of the word, overlooking the fact that the most influential European languages are more or less Keltic, except the German, if that be an exception. Now, the aim, as it appears to me, should be to reduce all forms of a word to its simplest, that is, the crude form, and thence the primary signification would be obtainable; and in its various transformations would be found the history of the word, and, *pro tanto*, the history of the race. The crude form of metal, or *metallum*, appears to me to be in K. *miotaille*, compounded of *miodh*, a diminishing or negative participle, and *ail*, a stone or rock; and signifying the worthless stone, or stone of little value. This meaning survives in the metal used for road-making, which usually consists of stone unfit for any other purpose; and until the art of smelting was discovered, the rock containing metal, the ore, was very unmanageable. So of the Latin *metallum*, which was applied not only to all kinds of ore, but also to marble, stone, and sand; in the present day, and for ages past, it has been specially applied to the most valuable products which can be extracted from rock or earth; and, metaphorically, to men and horses of spirit.

With the word *chemist* is habitually associated that of

* *Dict. Obs. and Pro. English*, in verb.

druggist; but I apprehend that the popular impression of the nature of a druggist's business is much less distinct than it is upon a chemist's. To say that a druggist deals in drugs does not produce more distinctness, for the question then arises, What is a drug? in a literal and not in the figurative sense. In Latham's edition of Johnson, a drug is described as a medicinal simple; in a commercial sense, as spice, such as ginger, cinnamon, etc. But, it seems to me, the two descriptions do not cover the whole range of a druggist's business, wholesale or retail; and that there is really not much difference between the druggist and the drysalter, though the latter is sometimes confused with the dealer in salt provisions. Webster, for example, describes him, from Fordyce, as a dealer in salted or dried meats, pickles, sauces, etc. In Liverpool, I find various firms describe themselves as spice, seed, and rice merchants; drysalters, manufacturers of mustard, chicory, etc., or as paint, colour, and varnish manufacturers; oil and drysaltery merchants; or, again, as drysalters, druggists, oil merchants, and dealers in vulcanised India-rubber and gutta-percha; whilst two others are styled drysalters and oil merchants, and drysalters and dyewood cutters. From all which I infer that druggists and drysalters are birds of a feather, and that their wares consist *de omnibus rebus, et quibusdam aliis*. A humorous broker, well known on the Liverpool Exchange, described Tate and Brady as successors to Sternhold and Hopkins, an old and highly respectable firm in the dry(p)saltery business. I suspect, however, that Theodore Hook came very near the mark, when he represented one of his characters in *Gilbert Gurney* as saying, that from a retail dabbler in driblets he became a merchant, a wholesale trafficker in everything, from a barrel of gunpowder to a pickled herring. In the civic acceptation of the word, a merchant; amongst the vulgar, a drysalter.

Ordinary etymology renders no aid, for the reference is simply to the French *drogue*, for drug; and to Saxon *dri*, *drig*, or *dryg*, for the prefix in drysalter. It has occurred to me that the word drug, and the prefix dry, possibly spring from the same root; one or both forms representing considerable modification. As the mineral salt appears to have but a remote connexion with numerous commodities in which drysalters trade, it did not appear likely to have any connexion with the designation, which, I think, is more probably from K. *solathar*, provision; a drysalter's special function being to provide for a number of traders the means of carrying on their respective operations; pronounced as a dissyllable, *solathar* will approach very nearly to salter. If this supposition be correct, the prefix will be relevant; and, if that be assumed to be K. *di-reic*, which may be rendered great, or, in modern phrase, wholesale dealer, the designation is apt, even with modern usage. In remoter ages, when business was not split up into so many sections, the aptness would be still greater. Turning for a moment from the wholesale provision dealer, is it not probable that the Sau't Market, in Glasgow, sacred to the memory of Baillie Nicol Jarvie, derived its name from the provisions there displayed, rather than from salt? Is there really any market in the world that is, or ever was, exclusively devoted to dealings in salt?

By substituting 'u' for 'ei,' in the second part of *di-reic*, and making the words monosyllabic, they become druc, and thence drug; thus the drugister, drugster, or druggist, was essentially the wholesale dealer; the middle-man between the retail dealers and the shipowner and importer, who, in primitive times, frequently commanded his own vessel.

The word minster is usually termed an abbreviation of monastery, though it is difficult to detect the resemblance without careful examination; and, in that, I am again thrown

upon Keltic roots. *K. man*, pronounced *maun*, signifies a solitary person; *manch*, a monk or friar; its resemblance to *W. mynach* is obvious. Passing other derivations, *manaistear*, sometimes *mainisdir*, is a monastery; manifestly *monaster* represents the first form of the word, the final *y* having been added on false analogy. From *mainisdir*, the transition to *minster* is apparent, and the formation of the suffix *-ster* is an obvious consequence of contraction into two syllables.

The crustacean known as the lobster, it is said, usually travels by walking or running on the surface of the water; it also swims; but, when alarmed, it arches its body, and, then relaxing it, moves rapidly backwards, flinging itself into its hole in the rocks, through an aperture barely wide enough to admit its body. This characteristic is expressed in the word of which lobster is a contracted variation. *K. lub-eistear* refers to this habit of arching its body; *lub* signifying a loop, a bow; and its derivatives, bending, winding, and, metaphorically, crafty, cunning, and deceitful.

The application in the eastern counties of the word lobster to the stoat is confirmatory of the etymology suggested; appearing due to its moving by leaps and bounds, as well as running with great speed; it is the only weasel that does leap, and it even turns somersaults.

Young soles are likewise called lobsters in Suffolk; they occasionally leap upwards and forwards, as may sometimes be observed in an aquarium; for that purpose, bending the body. Through the kindness of Mr. Moore, I have seen this action of young soles in the Museum, William Brown Street.

In the word oyster, probably, lurks some natural peculiarity of the mollusc, which, however, I have not been able to clear up satisfactorily. The Irish for oyster, *eisir*, the orthography of which varies, signifies the shield-fish, derived, doubtless, from the panoply of mail in which he is encased; another word, *uisaire*, or *uisire*, is applied both to oysters and

usurers ; probably implying that the latter are as close as oysters, and will never part with their possessions but with life itself.

I have sought for a root which should reconcile the Latin *ostrea* with the French *huitre*, the Welsh *wystrysan*, and the English oyster, but cannot hit upon anything more probable than *uis-eistear*, the humble pursuit, referring to its lowly attachment to the ground on which its spat fell, and 'from which it moves not until captured for the gourmand's maw. Analogous to this is the Irish name for the lark, *uiseog*, the humble bird, referring to its lowly habit of nesting on the ground, in its moist cabinet ; *uiseog-coille* is the woodlark, a member of the same family, who also builds on the ground.

The word upholsterer is sometimes adduced as an instance in which the formative element is repeated ; but it seems to me that in this and other instances the conclusion has been adopted without due consideration. Fisherman is not tautological, but distinctive of the men, who take the fish, from the women, still called in Scotland fisherwives, by whom the fish is sold. Indeed, within the last few months, it transpired in a police case in this neighbourhood, that women visit the sea-shore to take cockles and muscles, so that, in times and places, it is not impossible they may cast a net, or handle a rod. So also there are fisherboys and fishergirls. A fishwoman may be a mermaid, but a fisherwoman is unmistakable.

Nor do I see the double plural said to lurk in brethren ; for the singular form, brother, is apt, not only to revert to its early Keltic form of *brathair*, with the first "a" broad, as in French, but also to the fine vowel-sound of brither, as in Scotland. In his address to the *unco guid*, Burns urges them—

"Then gently scan your brither man.
Stiil gentler sister woman ;"

and britheren, contracted to brethren, would be the legitimate plural of the singular noun. The Irish have the diminutive form, *brathairin*, little brother. The word brethren is generally used in a special sense; it is seldom applied to the members of a family. In the authorised version, it is true that the Patriarchs are spoken of as Joseph and his brethren, but that is a somewhat exceptional use of the word, which, in its ordinary application, implies a company, society, or church. If the early use of the word was similar, then the suffix, instead of being a plural termination, is a modification of K. *-an*, which is an intensitive particle, implying that those to whom the word brethren is applied are brothers indeed. *An* also signifies union, unanimity, and, therefore, appropriate for an earnest association for special purposes.

So likewise with children, the suffix may have been applied originally to the childer of one household; then extended to those of the same hamlet or clan; and, ultimately, loosely applied to any aggregate, as at present.

Reverting to *upholsterer*,—and judging from analogy with the word *holster*, now confined to the leathern case in which a horseman carries his pistols, but which, probably, had a wider application formerly,—it seems to me that for ages there must have been something from which hangings were suspended. The word *valance*, by which that piece of furniture is now known, is a somewhat recent introduction from Spain; and it appears to have supplanted the indigenous word so completely, that the latter is lost. But that it was *upholster*, that is, a fixture whose purpose was to hold up, or uphold the hangings, appears to me very likely. The word *upholstar*, however, designating a dealer in old clothes, would discredit a word of similar sound though of different import, and so *valance* was readily accepted; while *upholstar*, as the title of a picker up of old articles, soon passed into oblivion almost as complete.

Granted a fixture called an upholster, and the title upholsterer is fit for the man who supplied and fixed it, and attached the hangings to it.

This suggestion receives some support from a comparison of the word fruiterer, now in use, with fruitestere, to be found in Chancer. As before explained, the suffix *-ster* represents K. *eistear*, a trade, or calling; fruitestere thence denotes the fruit trade, and fruiterer would be the appellation given to one who followed that trade. Fruitestere, like other words of the like formation, being contracted into fruiter, the trader would of course be termed a fruiterer; and thus the apparent reduplication proves non-existent.

The word huckster is usually referred to the Latin *augere*, the same root as that of auctioneer; but it seems to me that this is scarcely probable, as the huckster was originally a travelling dealer, like the pedlar, with, what Hood called, his little back shop, and the same as the hawker. The Gaelic for pedlar, *ceannaiche seachrain*, or straying merchant, aptly designates his usual vocation for centuries; but mention is sometimes made of pedlars' shops, and shops where pedlary can be obtained, which indicate that persons who follow the trade occasionally become stationary, yet retain the appellation. In fact, pedlary, like huckstering, is symbolical of contracted notions, in that metaphorical application of simple words which is noticeable in all languages.

I find hawkers described as those deceitful fellows who went from place to place, buying and selling brass, pewter, and other goods and merchandise, which ought to be uttered in open market; and it is suggested that the appellation seems to grow from these uncertain, wandering-like persons; who, with hawks, seek their game where they can find it. Rejecting this suggestion, as allied to that mythological etymology which has been the bane of true philology, I

conjecture that the root is to be found in some word expressive of their wandering life. This I find in K. *achdra*, an expedition by sea or land; G. *achdran*, an adventurer; and the two forms of hawker and huckster, for hauckster, have their analogy in other words.

I apprehend that mysterious word *coster* is allied to hawker, huckster, and pedlar; to suppose it a corruption of *costard*, the name of a kind of apple, seems very far fetched, for it is not likely that any number of persons would make a trade of one kind of apple. In the present day, I think, the word *costermonger* is seldom used out of London, where it is a local or provincial name for dealers in green-grocery, who carry their wares on barrows from house to house. They are, therefore, a species of pedlar or hawker, and possibly, in early times, dealt in a greater variety of wares, before trades were so much specialised.

I have shown above that the word *monger* is of Keltic origin; and similarly may be derived *ca(cau)-eistear*; and thus a *costermonger* is one who deals in a house-trade; that is, he takes his wares to the houses to find customers, instead of waiting for householders to come to his shop. Possibly to this custom we are indebted for the words, in nautical phraseology, *coaster*, *coasting*, and *coast*.

It is pretty clear that the suffix *-ster* has not an essentially feminine signification; but to one word that meaning is indelibly attached, through the technical sense in which it is now used by the legal profession; I mean the title *spinster*,

" O word of fear !
Unpleasing to the maiden's ear,"

in which it often sounds amiss. In other words, however, the suffix is applied indifferently to masculine, feminine, and neuter.

The root assigned to the suffix *-eistear* is resolvable into

two words, *eis* and *tir*, signifying a man's land ; and so takes us back to that remote period when trades were not, and the people of these islands depended upon the plot of ground, a rood or more, which "maintained its man," and the right to which, under Odall tenure, was inalienable. The Gaelic for subsistence, *teachd ann tir aran*, coming into bread land, conveys an analogous idea, especially if I am correct in supposing *teachd* to signify a coming in, or entering, under a legal right.

Another fact that appears to me established, is the essentially Keltic origin of the suffix *-ster*. The A.-S. dialect is unable to give any specific interpretation of the syllable ; in that phraseology it is an arbitrary termination only. In Irish the suffix is found as a living word, full of appropriate meaning, which fits it for the office it has filled for so many centuries, and to which it is still applied in additions to our copious vocabulary. If this be so, then it seems clear that, as has been said before, the English language is essentially Keltic.

Let me not be misunderstood. I am not an unreasonable Keltomaniac, whatever may be implied by the clumsy banter of a writer in the *Saturday Review* ; I do not follow Vallancey and Betham in their speculations, which appear to me very wild ; nor do I agree with Shaw, that Gaelic is the language of Japhet, spoken before the Deluge, and probably the speech of Paradise ; but I do believe it to be the basis of every form of speech which has been current in these islands within the historic period. I have endeavoured, by the careful collection of facts and probabilities, to test that conclusion ; and, hitherto, I have found abundant confirmation in the facts of history ; in legislative enactments ; in manners and customs ; in speech, and in local names ; and I submit such an inquiry is not unworthy of the respectful consideration it has hitherto received from this Society.

6
MARQUESAN TRADITION OF THE DELUGE.

By J. LINTON PALMER.

I FOUND among my notes, a few days since, a Tradition Legend of the Deluge, which I met with in a rather out-of-the-way place, the Marquesas Islands. As this legend has so many points in common with the account of the same event as preserved by the Chaldæans and Hebrews, and differs from those of other tribes or nations, I am induced to ask you to let me read it to you, but must preface some short account of the place and its inhabitants, which I hope will not weary you. Every year these legends are getting more difficult to obtain, and, I am told, principally because the natives, on embracing Christianity, are taught to consider them worthless.

DESCRIPTION.

The Marquesas Islands, eleven in number, form a group in the South Pacific, lat. 10° south, long. 140° west. They were discovered in July, 1595, by Don Alonzo Mendana de Neogo, who named the group after the then Viceroy of Peru, Mendoza, Marques de Canete.

They have been repeatedly visited by navigators of repute, among whom are Cook, 1774; Le Marchand, 1791; Roberts (American), 1797, who stayed for three months at Santa Christina; Wilson, 1797; and Admiral Krusenstern. The best accounts are by the two latter writers. The French took possession of them in April, 1852, by Admiral du Petit Thouars, a fortnight before the coming of the English Squadron, under Sir Fairfax Moresby, to whose flag-ship, the *Portland*, I was attached.

The three principal islands are—

(1) Hiva-oa, or Dominica, the largest and most fertile, about the size of the Isle of Wight.

(2) Nukuhiva, where the French Establishment is, and the scene of the charming novel of Herman Melville, *Typee*.

(3) Fatuhiva, or Magdalena, the southernmost.

They are fine islands, and must, from their internal evidence, have been very populated; but by the importation of small-pox (in the Peruvian coolie-raid, 1864), their numbers were decimated; in consequence of this disease, the natives assert, even the fecundity of the women was diminished. The disease, too, was spread by the reckless ignorance of the natives, who could not understand infection. A man has been seen to take the pipe from the mouth of a semi-moribund, and smoke it.

As a type of the group, let me take Nukuhiva, a bold, rugged volcanic mass, with hills three thousand six hundred feet high, furrowed by deep valleys, full of magnificent trees, palms, breadfruit, chestnut (Mahinei), vee-apple, orange, guava (quite a pest), plantains, and exquisite ferns; plenty of streams, mineral springs, soda-water springs; flowers in abundance, of shrubs, climbers, and orchids.

Animals are very few; imported oxen nearly, if not quite, wild; pigs, quite so. Birds are few in number; domestic fowl, wild, which have forgotten how to crow, but are very good as food. Among insects, splendid butterflies; mosquitoes are very virulent. The centipede is the only noxious one. It grows to a large size here, and is much respected, as it is supposed to be able to bequeath its vengeance. Hence, unless there is a fire near in which to consume it, no native will kill it, or allow it to be killed.

The climate is very agreeable, though rather warm. I see the heat ranged, during our visit, from 74° to 84° Fahrenheit. It is difficult to form an estimate of the

number of the inhabitants now. Fifteen years ago, the whole group was supposed to have twelve thousand.

INHABITANTS.

In Nukuhiva, which has about two thousand seven hundred people, the natives are divided into ten tribes, subdivided into families, each quite independent of the other, and governed by a chief, who is responsible for all its doings. The option of peace or war is vested in him. The land of a tribe, usually a valley, is held in his name. To each individual is allotted a portion, which he can use as he best thinks fit; and each family is very jealous of any infringement of the boundary of their portion by any other family.

Their agriculture is very simple. The plants cultivated are the sweet potato, arum, sugar-cane, and dracæna; plantains and bananas, requiring no attention.

They make fishponds in the course of the streams, for a long distance from the sea.

They are a fine-looking race of people, a good deal like the New Zealander, the men in height rarely above five feet ten inches, well formed, though rather slender limbed, as a rule; the women much smaller in proportion than the men; their colour a light olive brown, even as light as an European, and though the lips are full they have no negro expression.

They used to tattoo elaborately, that of the faces of the women was restricted to a few lines on the lower lip.

The lobes of the ear are perforated, and the hole so enlarged as to carry an ear ornament of even two inches long.

They remove all the hair which they deem superfluous by plucking it out. The hair of the head is dressed in various ways by the men. They usually shave *paths* in it, so to say, as you see by the sketches; but, strangely, the women do not seem to care to put themselves to any trouble in its adornment.

Their ordinary clothing is very scanty, that of the men frequently the maro only; that of the women a loose robe of tappa (native paper-cloth), which reaches from the waist to the ankles. If the sun is very hot, a part is thrown over the shoulders.

They are very fond of the bath, and anoint themselves after it with cocoa-nut oil.

Marriage is a very voluntary affair, and they couple and separate when they will. The children may stay with either parent. While married, they are constant; and I do not think polygamy was practised.

Circumcision is a religious ceremony, and takes place at nine years of age.

Their houses are of matting and wood, and very well made, unequally gabled. Along the more upright side is the sleeping place, divided at five or six feet from the wall by a row of cocoa-nut logs, and at the wall is another set for the pillow. This space is covered with beautifully-made grass mats, that between it and the door being neatly paved with rounded stones; and it is kept very clean. To prevent damp, they are erected on squared platforms (called Pi-pi), four to six feet high, sometimes in two ascents, and made of large irregular-shaped stones.

It is *taboo* to wash the inside of a house.

There is no fire-place, that for cooking being an outside oven, a shallow, square, stone-walled pit. After having kindled a fire sufficient to heat the loose stones put into it, the food to be cooked is wrapped in the leaves of the arum, or banana, and put on the hot stones. The whole oven is then covered up, and after the time judged sufficient the food is removed. Pork is particularly nice when thus cooked. The staple food is *pöe*, a paste made of bread-fruit or plantains, which is allowed to turn a little acid before it is eaten. To us the taste was abominable. For drink they

use, as a rule, water; but for stimulants, *ava*, or palm toddy, or orange or vee-apple spirit, or any European spirit they can obtain.

CUSTOMS.

Burial.—Their mode of burial is singular. The corpse is put into a canoe, or wrapped in a bale of tappa or matting, and laid on a bier, raised on posts to some six or eight feet above ground. It remains there till decomposition has ended, then the bones are carried up into the mountains and hidden.

Tattoo.—Tattooing is not merely for ornament. The different parts of the body and limbs so marked are supposed to be by it exempted from disease or pain. This discoloration, common enough through the world, is thus caused in Nukuhiva. The staining material is the soot of the candle-nut (*Aleurites*), rubbed into a paste with water. The implement is the serrated edge of the wing-bone of the tropic-bird (*Phæton*), which is put on the skin and tapped with a wooden mallet.

The lines about the lips are a spell against toothache and hunger; those about the eyes for keen sight; those on the chest, against javelins and musket shot (I may mention that they are ignorant of the use of the bow); about the joints, to ward off rheumatism or sprains. Lads were tattooed at fifteen years of age. The lines about the eyes were the first made, and while they were being made the patient was secluded and dieted to prevent inflammation of those organs. Although the practice is now suppressed, and made a punishable offence, by the French, I was, in 1869, in a tattoo-house seeing its performance. I must say, the natives did not manifest the stoicism of Fenimore Cooper's wild Indians.

Sorcery.—There is in these islands a class of people

called Umokoo and Manikaha (Fasteners and Sinnet-plaiters). They are sorcerers, and work by means of roots, and prayers to the god Tupaamo, who causes the death of their victim. The Umoko causes sickness and death, by working on the spirits and vital energy of those who come under its influence; the Kaha, by preying on the body and mind. Both are fearful weapons in the hands of those who wield them; and there is no islander, from the High Chief to the lowest commoner, who is not afraid of the sorcerer. More deaths are attributed to sorcery than to any other cause. If anyone dies from fever, consumption, or old age, the people usually ascribe it to the influence of Kaha. A fall from a tree, drowning, death from a bullet; yes, the man was under Kaha. Miscarriage, or still birth? Kaha was present in the mother. So that all ailments are ascribed either to Umoko or Kaha; and if anyone in robust health is told he is under the spell, he will most probably sicken in consequence.

The sorcerer does not practise his art till he is forty years old, and to become an adept a long apprenticeship is necessary. Therefore, an old sorcerer usually selects, from childhood, some member of his family to follow in his steps. Large fees for tuition are demanded from anyone not of the family. As early as possible, prayers and incantations are learnt by the pupil. At certain seasons, master and pupil dwell together in a house, tabooed, in the strictest seclusion, not communicating with the outside world, living very regularly, and bathing in salt water. A sorcerer rarely exerts his power on his own account, but receives fees for putting the enemies of his clients under the spell, and similar fees for relieving the same people, so that the sorcerer's family get large presents.

These two classes of sorcerers are also quite distinct; the one, as a rule, not having any knowledge of the art

practised by the other ; very rarely is one sorcerer an adept in both methods.

1st. The Umoko, to exert his art, must first get the spirit of his intended victim into his power. To this end he uses two instruments, a cocoa-nut leaf and a bowl of water. After retiring into his sanctum, he invokes by prayer the aid of his god Tupaamo. If the god is propitious, on looking into the bowl of water the spirit is seen at the bottom of it, and there the sorcerer secures it. Should the cocoa-nut leaf be preferred, it must be planted in the path of the person to be affected, on whose stepping over it the spirit leaves the body, and enters into the leaf.

After thus obtaining the spirit, the sorcerer again prays, and according to the character of the prayer, or incantation, so is the intensity of the pain, or duration of the life, of the victim.

In case of suspected theft, when the sorcerer has detected the thief, he puts him under a spell, to be removed only by confession and penalty-fee.

2nd. *Kaha* is performed thus by the adept. A piece of matting made of cocoa-nut fibre, eight inches by three inches, is tied up so as to represent an image, with a head, two projections for arms, and two for legs. A band crosses the trunk at the chest, and on this is placed the material to be worked upon. The adept retires into privacy with this, taking plenty of *kava* (intoxicating drink), *pöe-pöe* (breadfruit dough) for food, also some of the saliva or dejecta of the victim, or some piece of the clothing he is in the habit of wearing. The preference is given to the first two, as least liable to be followed by mistake.

Tribes, families, and individuals at feud employ these sorcerers, and take care not to leave about or behind them anything which may compromise them. Their dejecta are concealed with the greatest care, after the manner of cats and

wild beasts. The material to be worked on is called *Momo*. Placing it on the cross-band of the doll, the sorcerer invokes his god. If the prayer is efficacious, the victim soon becomes affected, but as long as the image is suspended there is no fear of death. To accomplish this the *Kaha* must be buried, and the time which must elapse before its occurrence is dependent on the depth of the grave—the deeper the sooner; but the victim may linger for months if the *Kaha* is only just covered with earth.

Cannibalism.—The Marquesans were notorious cannibals, and even now (1869) it is a custom in Hiva-oa (Dominica). Far from being an alimentary practice, it is usually consequent on revenge or religious observance, though in times of extreme scarcity the people of Nukuhiva have eaten their wives and children. This is the history of one feast which happened in Nukuhiva some few years since. Two chiefs quarrelled, and one was treated with indignity. On his return to the tribe-valley, he caused the war-drum to be beaten, and sent cocoa-nut leaves, “The Fiery Cross,” to other valleys. Where these were accepted, it was a proof the people would come to his feast.

The French, who had a settlement in the island, tried to appease the quarrel and settle the feud. But the chief replied that the usages of his fathers, which had fallen much into desuetude, would now be revived. After much negotiation, the head chief of Nukuhiva was persuaded to collect a force and stop the quarrel; but it led to a series of petty squabbles and reprisals, in the course of which sixteen people were eaten.

My informant, who was never, of course, present at these feasts, but which, he says, even now exist, told me the origin is usually revenge, not a craving for man’s flesh. Far from longing for man-meat, he had seen cases where the loathing to eat it was extreme. Sometimes the portion was secreted,

or buried; and always, before *this* particular aliment was served, plenty of pork and fowl was used. The flesh was highly seasoned, and yet frequently uncontrollable nausea was produced.* I remember our guide, in the Akani valley, on our arrival at the place, platform and pit of the cannibal feast, telling us that the reason of the banquet was scorn and revenge after a fight. He pointed to the place where his brother was killed. He said, "There were too many opponents killed to be eaten," but he never said he enjoyed it; quite the reverse. The bones of the arms and legs were removed by incisions down the inside of the limbs; the body was eviscerated. It was all made into a bundle, and cooked in the oven, having been wrapped up in taro leaves. I may say, the head was not so used.

Creed and Cultus.—This is always difficult to find out amongst savages, unless during a protracted stay; yet, on their original monotheism, their belief in O'Atua or Atea, the root of the cause, the God of Gods, primal and omnipotent, much addition of subordinate divinity has been engrafted. Now, it seems that their only belief of a God is some spirit of the dead, which will come at all times of want, sickness, or hunger. Each has his own "profession-god," so to say. The fisherman's is Ko-iki, god of luck; that of the landsman, Potini, god of plenty, and so on.

Now, too, they have no idea of after-life, annihilation seeming their end; but warriors were supposed to be in a paradise; and they think the spirits of their dead can revisit them, and they revere the *manes* of their ancestors. It is very involved.

Taboo.—This is in force here, as well as in most Polyneesian islands, where the chief is high-priest as well as ruler. If he draws this magic circle, so to say, round any man,

* Marcey, in his *Journey across South America*, 1878, notices analogous circumstances among the Mesaya tribe. Vol. iv., p. 448.

native or foreigner, his person is inviolable; no one would dare to injure or molest him. Hence most foreigners, who are castaways or runaways, are under this rite, and many have lived peaceably for many years in these cannibal islands.

The same ceremony is applied to crops, or tilled ground. It is then called *Rahui*.*

There is, of course, some sign of the crop or ground being tabooed. In Easter Island, as I have shown, this mark was a number of little cairns of whitened stones, so as to warn anyone against the sacrilege he would incur by infringing the rite.

Human Sacrifice.—This was in use here, as in many other islands. When things had gone wrong,—defeat, failure of crop, or sickness,—the priests declared a victim was necessary. This was generally a stranger from some other island. If none was to be had, some families had the unenviable distinction of being able to furnish a victim most pleasing to the gods. One was selected, and tabooed, so that even his most intimate friend could not tell him of his fate. Certain persons, to whom a black stone was given, were selected for his death. He was generally stunned by a club and killed at some unguarded moment, but in case of resistance overpowered and killed. The corpse was brought to the appointed place, some open spot near the village. The whole tribe collected, and celebrated the sacrifice with dance and chant, while the victim was being suspended to a tree.

The man who had been sacrificed just before the arrival of the *Portland*, at Oahuga (Washington Island), was a native of Hiva-oa (Dominica). He was hung up not far from the anchorage.

Visitors.—From the position of these islands, with regard

* On the occasion of a cricket match, near Honolulu, in 1853, the ground was tabooed by King Ka meha meha, so that the valuables, etc., of the players should be safe from the pilfering of the natives. I was assured it was "quite a charm."

to the sperm whale fishery, they are very often called at by the whalers for supplies, and for years natives have been taken for a cruise in the ships. Many of the sailors, also, have deserted, and lived on the islands. Some men have acquired lands and herds, as, for example, Captain Johnson, who owned a considerable farm in Oahuga, at the *Portland's* visit, 1852. He had several Europeans in his employ. He supplied the whalers with "fresh meat and vegetables" when they called. Of course, he and his men were "under taboo," and had no fear for their personal safety.

When the *Topaze* anchored at Vatihua, in 1867, we found a Birmingham man, of the name of Josiah Upton. He was "tabooed," and under the strict surveillance of the chief's son, who acted as his body-guard, and was seemingly much attached to him. He had been for years on the island, and had taught some of the islanders to read and write. We helped him, I remember, with stationery and books. He was very infirm, and said he did not wish to leave; he was unable to gain his bread in England, and was most tenderly cared for by the natives. He said he thought there were about twenty-five runaways in the islands.

LAWSON, AND THE DELUGE LEGEND.

Thos. C. Lawson, from whose dictation we copied several legends and chants, was an Englishman, mate of a whaler, which he left in 1848, and so had been in the various islands some twenty-four years. Till 1864, he had good health. His age was about forty-seven.

He seemed a very intelligent man, and did not appear to have any preconceived notions as to the meaning of their chants, etc. He was very frequently on board *H.M.S. Topaze* during our stay.

He had heard these chants constantly among the people, among whom they have been transmitted orally for many

generations. When he formed the plan of compiling them, he copied them from the dictation of the oldest chiefs and people, as Sir G. Grey did those of New Zealand.

He says he does not remember to have ever seen any picture writing or hieroglyphic used. Hence many *hiatus* occur, and some of the sentences are so obscure that, though he is a perfect master of their talk, he cannot at all understand them. Some legends he tried to put into English, in the same metre as the original, and, though he has preserved the meaning of the words, the diction is puerile.

On our making further inquiries, he said it seemed to him that this people must have migrated from the East.* They say so, and their tradition confirms the idea.

He readily gave us these legends, but asked us not to publish them, as he was aware of their imperfections, and was still trying to fill up the gaps; hence I have refrained till now.

MIGRATION OF THE ISLANDERS. BY LAWSON.

Resting Places.—The following are the places at which the natives say they halted on their journey from the East.

- 1 *Vahitaki* . . . Shining place; glorious land.
- 2 *O-au-mi* . . . Large, flat; leaves grow large.
- 3 *Papa nui* . . . Large, flat island or plain.
- 4 *Taki-hee* . . . Shining road; fair, glorious.
- 5 *T'e-mea-ai* . . . A place of plenty.
- 6 *Tapu-oua* . . . The sacred spot.
- 7 *Ani-taki* . . . Shining sky.
- 8 *Hawaii* Difficult passage; dangerous journey.
- 9 *Tetu-uma* . . . The gift; place given.
- 10 *Matako* Place with precipitous coast.
- 11 *Pi ina* Place of rest or stay.
- 12 *Tai-houa* . . . Deep water, or sea.

* Main land of Asia.

- 13 *Nea-poa* . . . Day's end ; late in the day.
14 *Hu-u-iva* . . . Place on one side of the place dwelt on.
15 *Aauna* To windward, or to rising sun.
16 *Tatu-ata* . . . Applied to dusk, or getting dark.
17 *Hiva-oa* . . . A far distant place.
18 *Fatu-ua* . . . Destroyed ; upset.
19 *Moho-toni* . . Moho is a caste or clan, tattooed down
the breast ; the place of sound, or
voice of Moho.
20 *Fatuhiva* . . . Place still further off.
21 *Motu-nao* . . . Last island or place.

“ From their arrival at Hawaii till the present time is a matter here of undisputed history, and I have not the least doubt but that they have good traditional history from Vahitaki till their arrival at Hawaii, but as I do not know it at present, I leave this alone ” (Lawson—conversation).

MARQUESAN TRADITION OF THE DELUGE.

Translation.

The history of the Flood, Papatiki, caused by the destroyer, Te Haka Nana Atua. Told to me, T. C. Lawson, by Vehi-ite, of Hana-uhi.

The Lord of ocean is going to overflow the dry earth ;
A period yet shall await, yet lights opening seem ;
Oh, who would have thought of the great earth being
Deluged, oh ! by a sea flood, a coming, eh !
Ho, ho, the enclosure, ho, ho, the braided cord !
Ho, ho, here is confusion among the generations of the beasts.
O me, a sea ! O me, a sea !
O we are reserved aside from the sea !
Reserved in generations from the sea coming, eh !
Here is the generations of the beasts—
A sea flood coming, eh !

The generation of the whites—a sea flood coming, eh !
 The generation of the stripes—a sea flood coming, eh !
 The generation of the spots—a sea flood coming, eh !
 The generation of the black—a sea flood coming, eh !
 The generation of the brown—a sea flood coming, eh !
 The generation of the long tails—a sea flood coming, eh !
 The generation of the short tails—a sea flood coming, eh !
 Oh, the sea flood is coming, eh !
 A man in front—Eh ! the coming bearing ,
 A man behind—Eh ! the coming thousand !
 Beasts between, then a sounding,
 For the preserving of the generations of the beasts,
 There must be a storied house, a room house,
 Oh, the sea flood is coming.

Chant repeated, from “The generation of the whites.”

(Bearer)
 Eh, Amo eh ! E Ta ! Eh, bear the beasts,
 Bear them in tribes. Eh ! a long rope to bind ;
 Oh, an enveloped house, oh, the maker and destroyer God ;
 Oh, Hina-touti-ai ! oh, Hina to hapu motu ;
 Oh, Hina te ao ihi ! oh, Hina te ao miha ;
 Oh, the sea flood is coming, is coming, eh !
 A man in front—Oh, Lord of Ocean,
 A man in rear—Oh, the flood from the sky ;
 A turtle between. Then a sounding.

.

Tip, tip, thy ear, tis bad thus
 To cook food for the Maker's atoning sacrifice ;
 The priests four—atone the sacrifice.*

.

The house asleep. God, maker, destroyer ! †

.

Crushed generations stink.

.

Held here together are, all heaven's whole fed people ;
 The sacred upright sleep.

* *Transactions of the Society of Biblical Archaeology*, vol. iii, p. 545.

† *Ibid.*, p. 553.

To this song sing. Maker sing!
 Boy maker arise. Maker I will.

Here is an opening out of war,
 A rain-like shadow one;
 Held together here, all heaven's whole fed people.
 Slept while the earth did overturn and quake;*
 Ia has given back to the bystanders a song,
 Bystanders sing! oh, bystanders arise, oh, sing,
 This is my will, my will—
 Here is an opening out of war,
 A war to many opened on,
 And there is coming a work here.

PART SECOND.

Eh! the summits new of the mountain ridges,
 Lo! behold there, an angel-man trumpets,
 Again here. Generations in the war;
 A message in the brain, a push in the hand,
 A trumpeting, come, push the ocean back again.
 Eh, rooms! eh, landing!
 The Lord of Ocean, the Lord of Ocean wills it.
 Ah, quick the summits long,
 A summit new fast comes!
 Eh, you! eh, behold! in channels emptying,
 And seven holy things, and seven by part shall cry,
 The Lord of Ocean, the Lord of Ocean wills it.

Eh, embark! ribs of Tanaoa,
 Embark on the sea of Havaii, thy bones,
 Ah, go forth! thy bones, ah, go forth.

Eh, rest Tanaoa on the bow, rest Tanaoa on the stern of
 the canoe,
 Eh, flap, flap thy wing, Tanaoa,
 Oh! Tanaoa, I will thee, Hia; why dost thou not return?
 The north wind has returned with the heat.
 Flap, flap on thy ribs, Tanaoa, I will thee, Hia;
 Eh, rest on the sands, Tanaoa;

* *Ibid.*, p. 555.

Eh, call Tanaoa, is there return ?
 Do not go away ! eh, flap thy ribs, Tanaoa,
Mo-epo Eh, the embarked ribs of "night sleep,"
 Eh, embarked-sea of Havaii,
 Thy bones, ah, go forth ! thy bones, ah, go forth !

Eh, now he alight, the four cups, cups—
 The Lord of Ocean wills, eh, Hia !
 Ridges great were the ridges of Havaii,
 Ridges new are the new surface ;
 The kick—the stamp. There is "night sleep,"
 Bringing back a gleam of bad rain,
 The face has brought. Like Maker that.

PART THIRD.

Ask, ask, the flower ? Generations new, generations gone,
 Who is the flower above here ? Oh, this way I return ;
 Oh, the image leg one, Maker wills it.
 Ask, ask the standing flower, who is the flower inland here ?
 Oh, enveloped with hair ;
 Maker with white teeth. Maker wills it,
 Ask, ask the flower, the inland flower ;
 Oh, it is the Lord of Ocean, a-going to go,
 A-going to curse the standing flower below here ;
 Oh, the black blast, oh, the blast of black.
 Oh, who is the flower over there ?
 It is my face the water. }
 Oh, who is the flower seaward here ? } Repeated.
 It is the sacred one.
 Oh, I am the tree to replenish the earth ;
 Oh, it is the abundance, the rainbow
 Oh, and who is here ?—the flower, the sacred one.
 Oh, I am the tree to replenish the earth.

Same in Vernacular.

Te Fatu moana no hoe ia e taku tu mooa
 He koina e vae ana, na moatea ehitu
 Oai tutu e tomina, o te Papanui tunaka
 Mai Tai toko, he fetu e !

Ho ho! te papua! ho ho te hau hi!
 Ho! ia e tohu ia vavenna te tai o te puaa
 Ho mana hake iho e tai. (Repeated.)
 E! ke iho etai e tai toko. E! fetu eh!
 Eia te tai o te tai puaa
 Te tai toko! E fetu eh!
 Te tai o te mona, te tai ha hei
 Te tai o te patipati, te tai o te papanu
 Te tai o te kivi kivi, te tai o te huho-ou
 Te tai o te huho poto:
 Te tai toko, e Fetu eh!
 He enata i mua. O Fetu amo amo
 He enata i nui. O ta fetu tini
 Puua te vavenna, e toni hu ina.
 E te tai toko, e Fetu eh. (Repeated.)

Chant repeated from "Te tai o te mona."

E amo e! e ta! E amo te puua!
 E amo etu e tai. He fau va ke enata!
 O kaka vere oa! O te kaka nana Atua!
 Oh! Hina touti aui! Oh! Hina to hapu motu!
 Oh! Hina te ao ihi! Oh! Hina te ao miha!
 E te tai toko. E! Fetu e!
 He enata i mua. O te Fetu moana.
 He enata i nui. O te Tau ani!
 He Hono te Vavenna! E toni hu ina.
 E te tai toko! E Fetu e!
 Tipia tipia to puaina. He fai pe ia
 Mea tuna ai te Atua. Ke huku ko hoko
 Te tana mata fa. Ke huha ko huha
 Fae momoe. Atua te Haka nana

Ami pu (hu?). Tai piau

E hau ia ko hua, e hau ia o toa ta fae huua
 Moe te tapu tutui. Moe Atua nui
 Ma Atua va. Atua kahi,
 Eia e atea he tona, he tona to mea nui Ia atea
 Eia e fetu ina he hava nei.

He ua mea ata taki
 E hau ia kohua ani o toa ta fae huaa
 Moe te tapu tupui te au a te fenua
 N'au e ae tunata te matu ke nui
 Matu ha nui ha nui. Matu ha va ha va
 Matu t'au kaki tenei t'au kaki tenei.

PART SECOND.

E te kou hou no te vaou no te mota
 He mo nu enata, tu ana nei
 Tai ite tona, he pai ita oho
 He pai i te ima, e tutu tia mai e hoa
 Te Moano ia vena, e puho e kau ai au
 Te Fatu Moana, Te Fatu Moana, kaki ia !
 Na aue te kou oa
 He kou hou tia mai e ae te mota
 I hava miki ia te Fatu Moana
 Ha aue te kou oa, hou ha te mota
 A ehitu tapu tae-tae, a ehitu mamau ha tere ve
 Te Fatu Moana, kaki ia !
 E te tie te voa, no Tanaoa e te tee tai Hawaii
 To ivi ha ke atu, to ivi hake mai
 E no ho Tanaoa, no te hae hae
 E ma hoe Tanaoa, te mui o te vaa.

E paki-paki to voa Tanaoa, Tanaoa au kaki, Hia !
 Tanaoa hea ha ta oe, na hua
 Ha hua te tui me te hapa
 E paki-paki to voa Tanaoa, Tanaoa au kaki, Hia !
 E no ho Tanaoa i te oui-oui
 E vevau Tanaoa ina tahu mai.
 E paki-paki to voa Tanaoa, Tanaoa au ku, Hia !
 E te tee voa no Moepo, O te tee tai O Hawaii
 To ivi kake atu, to ivi kake mai.

E hai ha tau. Te efa Ipu, Ipu,
 Te Fatu Moana kaki. E ! Hia
 Vaaa nui te vaaa Hawaii
 Vaaa nui te vaaa mata hou.

Te kiha he te kaki,
 Eia te Moeipo ua hai mai kohe, kohe
 Pe ua te mata e hai !
 Mea Atua teua papa etua.

PART THIRD:

Hui Hui te pua, tai hou, tai hee
 Oui te pua una nei. O Ati te aua
 Te tiki vae taki Atua kaki ia
 Hui Hui te tu pau, oui te pua una nei,
 O Kaka me vau, Atua niho teea, Atua kaki ia
 Hui Hui te tu pua oui te pua tai nei
 O te Fatu Moana ma hae ia na hoe e too
 Te tu pua, ini nei. O te Pui keke
 Te pui o oho ino. O oui te pua naki
 O te enata (mata?) te vai. O oui te pua (inua?) nei
 O te ono tapu. O oui te pua (inua?) nei
 O mau te anua nua. O oui te pua heva nei
 O hau te huua tupu fenua.

NOTES BY LAWSON.

The word *Tai* means a generation ; also, the sea.

O Fetu amo—A man in front ; the word *amo* means to bear ; a bearer of burdens.

O te Fetu tini—*Ta* or *tini* means a thousand ; Oh ! here 's a coming thousand.

O Kaka vere oa—A house made to float. Derivation—*Kaka*, to envelope ; *vere*, wood ; *oa*, long.

O te Kaka vau Atua—*Kaka*, to work ; *vau*, to loose ; *Atua*, God ; the God of the Destruction.

O Hina, etc.—The names of the four women saved from the flood. *Hina* means to fall, or be overcome. It is a constituent in the name of all the Marquesan women, which contains many words. The name of the first woman was *Hina Hea* (*Heva*, *Eve* ?)

Hina touti ani—The fallen going to the sky.

Hina ao ihi—The fallen air, that blights or heals the skin.

Hina to hapu motu—The fallen overturning or lifting up the island.

Hinu to ao miha—The fallen air that desolates.

Hono means a turtle.

The old form of worship was by tipping the ear.

Fae momoe—House asleep. By this it would seem the deluge came in the night.

He mo nu enata.—This is the only place I know of, in the whole Marquesan mythology, where any person is represented equivalent to our word Angel. The name is derived from *ano*, to enter or penetrate; *enata*, a man. *Enata* is derived from *nata*, to bind, alluding to the binding of soul and body. It is equivalent to "sky-enter-bound."

Tanaoa is the name of the god of the north wind, "dark-long."

*Moepo**—Name derived from *moe*, sleep, *po*, night; a common name in Marquesas. One of their ancient ancestors.

"I suppose *Tanaoa* to be the raven; *Moepo*, the dove."

Ta efa Ipu Ipu—The four men are represented as cups, or vessels. *Havaii*, the world before, *mata hou*, "new surface," the world after, the flood.

The new assumed names of the eight people leaving the ark are—

O Ati te Ana ti tiki vai taki.

O Kaka me van Atua niho teea.

O te Fatu Moana.

O te Puhi keke te puhi te ono-ino.

O te mata te vai.

O te ono tapu.

O mau te anna nua.

O hau ta huna tupu fenna.

With regard to the legend I have read, we all know that there has been a belief in a universal deluge, in all countries and among all people. That of the Chaldeans you will find in *Transact. Soc. Bib. Archæology*, vol. iii., part 2.

The Hebrew version is also well known. The Samo-thracian you will find in Humboldt's *Ausichten*. By the Mexican account, two people only escaped, Coxcox and Tezpi, in a bark. The Welsh deluge was caused by the bursting of

* Found in *The Hymn of O' Atea, The Dirge of Take-hee-hee*, etc.

the lake Leon. Two people only escaped, in an open boat. In the Peruvian narrative, some people were saved, but by climbing to caves in the Andes.

In Tahiti, the deluge is also from the sea, whose god, being insulted by a fisherman, overflowed by its waters the world; yet he saved the fisherman, his wife, and child, preserving them on an islet east of the sacred island Rai-atea. The waters rose in the night.

At p. 598 of the same vol. of *Transact. Soc. Bibl. Archæology*, you will find the Dyak tradition.

It is needless to quote more.

I will point out some essential points in the two circumstantial accounts.

In the Hebrew, sea and rain, rainbow, two bird-messengers, eight persons saved.

In the Chaldæan, rain only, no rainbow (unless the "Great Brightness" may be so rendered), the earthquake, three bird-messengers, seven sacred things, many people saved. As a coincidence, mention is made of Tutu, "the generator of the gods," equivalent to Tu-Atua-Tu-a Metea of the Polynesians. (Wyatt Gill's *Songs of the Pacific*, p. 6.)

There is hardly any account of these islands of the Pacific, in which the coincidences of their legends and biblical history is not adverted to, and even in the oldest this similarity is ascribed to teaching by Europeans; but there seems no positive ground for believing that this was the case.

FRAGMENTARY LEGEND OF THE CREATION.—MARQUESAS

ISLANDS.

High, high up in the boundless sky
 Work, work a storied mansiou,
 Clear all out from within,
 The cause is now without;

The tree of the cause shall soon arrive ;

The tree of the cause is arriving ;

O Atea is now within his house arrived,

And says, I will—Héré !

O Atea, the tree of the cause ;

O Atea, the pioneer, the husband of Atanua ;

O Atea, the Papa Una ; (Upper rock.)

O Atea, the husband of Papa Iao ; (Lower rock.)

O Atea, the lowermost rock ;

O Atea, the tree of all the gods ;

O Atea, the great begetter ;

God O Atea wills—Héré !

The sons of O Atea arrive, come ;

The sons of O Atea enter the house ;

O Tu Mea ! stand thou with me here :

O Natia, te pu ! stand thou with me here ;

O Natia, te pu, the king of heaven ;

O Kaka me Vau, the white tooth god ;

O Atu to au hua, the image leg one ;

O Mauiki, the god of fire ;

O Maui, Mauiki's younger brother.

* * * * *

REMARKS ON THE INTRODUCTION OF GEOLOGICAL MAPS.

BY GEORGE H. MORTON, F.G.S.

WILLIAM SMITH, who is justly considered to be the father of English Geology, circulated his *Tabular View of British Strata*, in 1799,* and after he had explored the whole country, and discovered the superposition of strata, completed his Geological Map of England and Wales in 1815. Although the first Geological Map of England and Wales was the work of William Smith, the *idea* of such a map did not originate with him.

There are many parts of the country where the difference between the rocks extending over definite areas is so remarkable, and their economic value so various, that the importance of a map showing the granite and the slate, the coal strata and the red sandstone, or the chalk and the clay, must have been suggested to observant minds long before. The practice of mining must at an early period have directed attention to the range and outcrop of the stratified rocks, and the direction of mineral veins; in fact, this is evident from the *Philosophi Clariss De Re Metallica*, a work by Georgii Agricolaë, who lived in the sixteenth century. Some of the numerous plates with which it is embellished prove that stratification, mineral veins, and faults, were all understood in his time. There are no maps, but a series of

* The author acknowledges much information derived from the following reliable sources, which may be consulted for authorities and fuller details:—

Introduction to the *Outlines of the Geology of England and Wales*, by Conybeare and Phillips, 1822.

"Notes on the History of English Geology," by Dr. Fitton, *Edinburgh Review*, Feb., 1818. Re-edited *London and Edinburgh Philosophical Magazine*, vol. 1 and 2, 1832-33.

Memoirs of William Smith LL.D., by John Phillips, F.R.S., 1844.

woodcuts showing the strike of the veins with regard to the contour of the country.

A History of Pembrokeshire, in MS., by George Owen, Esq., of Henllys, Lord of Kemes, &c., dated 1595, in the reign of Elizabeth, was published by his great grandson, Richard Fenton, Esq., in the *Cambrian Register* for 1796. In the manuscript the author describes the extent and range of the limestone underlying the coal strata of South Wales, and there are observations recorded, with examples of geological surveying, that it would be difficult to improve even in the present day. An extract from this History, containing what relates to coal, has been reprinted in Fenton's *Historical Tour through Pembrokeshire*.

In the *Philosophical Transactions*, for 1684, there is a Paper bearing the following title :—“*An Ingenious Proposal for a New Sort of Maps of Countries*; together with titles of sands and clays, such chiefly as are found in the north parts of England,” by Martin Lister, M.D., from which it seems that the author was the first who proposed “*Maps of Soiles*,” though it does not appear that he made any attempt to carry his design into execution. He, however, mentions the divisions he would have adopted for Yorkshire, and how the various deposits might be distinguished by different colours and shading. On the title of the Paper it is stated to have been drawn up about ten years before, and delivered March 12th, 1683, which seems to imply that his priority had been questioned.

The writers on the Deluge were numerous about this period, and the speculations as to the cause of the supposed flood are very curious. Burnet's *Theory of the Earth*, in 1697, contains numerous plates and maps, showing how the earth was fissured by the sun's rays, so that it burst, when water from the interior covered the surface. There is a map

showing the drowned earth, with the ark supported by guardian angels, but nothing like a geological map.

In the *Itinerarium Curiosum*, by William Stukeley, M.D., 1728, there is an article in the index, entitled, "Memoirs towards a British Map of Soils." The author gives a list of strata, viz :—

Chalk,	Red earth,
Freestone,	Coal cliffs,
Limestone,	Coal,
Marl,	Lead, copper, &c.,
Yellow earth,	

from which we may conclude that the order of the formations in England was known to possess a regular sequence. About the same time, John Strachey gave a similar succession of strata of Somersetshire.

In 1730, Christopher Packe, M.D., produced *A New Philosophico Chorographical Chart of East Kent*. It was a map showing the contour of the country, with the "stone hills" and the "clay hills," proving that the author knew the difference between the chalk and inferior deposits traversing the county.

Guettard, in 1746, was, perhaps, the first to try to carry out the idea of Lister, many years before. He divided the formations into three grand zones, viz.: the schistose, the marles, and the sands. He endeavoured to map Europe, Canada, and Asia Minor; in fact, he attempted so much, that he failed altogether.

Lehman, in 1756, supposed the coal strata to be the lowest rock in the stratified series, an opinion very generally entertained at that time.

In 1760, the Rev. J. Mitchell, in a paper "On the Cause and Phenomena of Earthquakes," published in the *Philosophical Transactions*, enters fully into the regular succession of the stratified rocks. The following section was found

after his death, bearing the London post mark of November 21st, 1788 :—

Chalk - - - - -	120 yards thick.
Galt - - - - -	50 "
Sand of Bedfordshire - -	10 or 20 "
Northamptonshire lime and Port- land limes, lying in several strata	100 "
Lyas strata - - - - -	70 or 100 "
Sand of Newark - - - - -	about 30 "
Red clay of Tuxford, and several red marls - - - - -	100 "
Sherewood Forest, pebbles and gravel - - - - -	50 "
Very fine white sand - - - - -	?
Roche Abbey and Brotherton limes	100 "
Coal strata of Yorkshire - - - - -	?

Another work, published in 1797, was entitled :—*Historical Atlas of England: Physical, Political, Astronomical, &c., from the Deluge to the present time.* By John Andrews, Geographer. The work seems to be incomplete—perhaps unfinished—but it contains a series of small maps (13 inches by 12 inches), containing the “yellow limestone” and the chalk ranges of hills.

Many other works containing maps might have been mentioned, but there is no evidence of stratigraphical knowledge on any of them. They are all either “Physical Maps,” “Mineral Maps,” or “Maps of Soils,” and there does not seem to have been anything resembling a geological map before 1790.

A mineral map may be defined as having the respective portions of the surface so coloured as to indicate the areas occupied by certain rocks or minerals, with regard to their lithological characters only. A map of soils indicates the

distribution of particular kinds of soil in an agricultural sense—not the mere vegetable mould, but the underlying clay, or sand, which is always intimately connected with the regular strata beneath. A geological map, however, not only shows the extent of each area occupied by the respective rock formations, but it indicates the relative position and relative age of each, with such further particulars as the size or scale of the map admits of.

Between the years 1790 and 1800, the Board of Agriculture published several volumes of Reports, containing much information; and this Board undoubtedly produced the earliest geological maps of any part of England, though they are very rudimentary when compared to the elaborate results of the present time. The Reports for 1794 contain maps of Devonshire, Nottinghamshire, Derbyshire, and the North and East Ridings of Yorkshire. Between 1794 and 1813, the same Board published useful maps of Wilts, Gloucester, Berks, Bedford, Surrey, Sussex, Lincoln, Cheshire, Lancashire, Durham, and many other counties. The primary object was to show the soils, but in many cases the stratified formations were at the same time defined in a rough fashion, so that some of them may be considered to be geological maps; for though there is no indication of stratigraphical knowledge upon them, the sections by Stukeley and Mitchell prove that the general order of succession of the strata had been known long before. In the absence of palæontological knowledge, it would have been very difficult, if not impossible, to have produced a map showing any minute subdivisions of the strata. The Board map of Lancashire defines the area of the Coal Measures and Carboniferous Limestone, and must be considered a geological map of the county; but those of the East and North Ridings of Yorkshire are little more than maps of the soil;* however, these three maps may

* The three maps were exhibited—from the Liverpool Library.

be considered average examples at the end of the last century.

Up to this period geology, as a science, had no existence. Fossils were collected and treasured up with great care, particularly in the neighbourhood of Bath, where there were many fine local collections, but very little was known of the exact relation of the fossils to living types, and they were principally regarded as curiosities. William Smith was the first person to point out their distribution along certain definite horizons, and that the same strata could be identified in distant localities, by the fossils they contained. His *Tabular View of British Strata*, circulated in 1799, was not printed, but manuscript copies were distributed, written by the Rev. B. Richardson, from Smith's dictation. The following is a copy of the original document, presented to the Geological Society in 1831 :—

Order of strata and their imbedded organic remains in the vicinity of Bath ; examined and proved prior to 1799.

	Thickness.
1 Chalk - - - - -	800
2 Sand - - - - -	70
3 Clay - - - - -	30
4 Sand and stone - - - - -	30.
5 Clay - - - - -	15
6 Forest marble - - - - -	10
7 Freestone - - - - -	60
8 Blue clay - - - - -	6
9 Yellow clay - - - - -	8
10 Fuller's earth - - - - -	6
11 Bastard earth and sundries - - - - -	80
12 Freestone - - - - -	30
13 Sand - - - - -	30
14 Blue marl - - - - -	40
15 Lias blue - - - - -	25

16 Lias white	- - - - -	15
17 Marlstone, indigo, and black marl	-	15
18 Red ground	- - - - -	180
19 Millstone.		
20 Pennant street.		
21 Grays.		
22 Cliff.		
23 Coal.		

In the original, there is a list of "Fossils, Petrifications," &c., and "Descriptive Characters and Situations," which are omitted. This document was extensively distributed, and remained for a long period the type and authority for the order of superposition of the strata around Bath. It was the groundwork of *A Geological Table of British Organised Fossils, which identify the Courses and Continuity of the Strata*, published many years afterwards, by the same author.

In the recent Loan Collection at South Kensington, there was exhibited *A New Map of five miles round the City of Bath*, 1799, geologically coloured, and signed "Wm. Smith," and *A General Map of Strata found in England and Wales*, 1801, by Wm. Smith, surveyor. They were presented to the Geological Society of London, in 1831, by the author; and they must be considered the earliest geological maps that have any claim to originality and correctness. The Map of England and Wales was the first attempt to show how a geological map of the whole country might be drawn. These, and similar maps and sections, were exhibited by Smith at agricultural meetings, and on other occasions. He did not keep his knowledge to himself, but so freely explained the principles on which he was working, that they were well known, and he distributed proposals for his large Map of England and Wales so early as 1801, the date of the small one referred to, which was not published. This being the case, the publication of his map was

not unexpected, for it had been the result of a life of labour, and finally appeared, after a long series of difficulties and delays, under the following title :—

A Delineation of the Strata of England and Wales, with part of Scotland, exhibiting the Collieries and Mines, the Marshes and Fenlands originally overflowed by the sea, and the varieties of Soil, according to the variations of the substrata, illustrated by the most descriptive Names and Places, and of Local Districts, by William Smith, mineral surveyor. In fifteen sheets, 1815. The size of the map, 8ft. 9in. high by 6ft. 2in. wide. A reduced form of the map was published in 1819.

It seems unfortunate that Smith did not communicate his discoveries and proposals, before the publication of the map, through the Royal Society, or some other recognised channel, for he would then have had his priority established in an authoritative form, before it was possible for his principles to have been applied by others. However, his extensive practice as a mineral surveyor afforded him such means of investigation in different parts of the country, that few could have competed with him, and he was finally able to produce his long-cherished object, *The Geological Map of England and Wales*, which will always remain a lasting monument of his original talent and extraordinary perseverance.

With the publication of Smith's Map, in 1815, geological maps came into general use. The Geological Society of London was established in 1807. In the first volume of *Transactions*, for 1811, there is no geological map, but in the second volume, for 1814, there are such maps of the Isle of Man, the Isle of Wight, the Hampshire, and the London Basins.

In 1819, G. B. Greenough's *Geological Map of England and Wales* was published, with more minute details. The engraving of the map itself is very superior to Smith's, so

that the colouring was executed with much greater precision and distinctness than was possible in his.

In 1822, Conybeare and Phillips produced a small geological map of England and Wales in their *Outlines of the Geology of England and Wales*. Many such maps of districts, at home and abroad, were published in the *Transactions of the Geological Society* and other publications.

Between 1819 and 1824, Smith published a series of county maps, twenty-four in number, on a larger scale than the large map.

In 1831, it was resolved by the Council of the Geological Society of London, "That the first Wollaston medal be given to Mr. William Smith, in consideration of his being a great original discoverer in English geology; and especially for his having been the first, in this country, to discover and to teach the identification of strata, and to determine their succession by means of their imbedded fossils;" and the medal was presented to him by the president, Professor Sedgwick, who gave a brief history of Smith's career, and spoke of him as "the father of English geology."

About 1837, the Ordnance Survey, and, finally, the Geological Survey, began to publish geological maps, which it is proposed will ultimately embrace the whole of the United Kingdom. These maps, coloured on those of the Ordnance Survey, are on several scales, and as complete as it is possible to make them. Of smaller, and consequently more accessible, maps, the following are the most reliable:—

Geological Map of England and Wales, by G. B. Greenough,

F.G.S., new and revised edition, by the Geological Society.

Ditto, ditto, by Professor Ramsay, F.R.S.

Ditto, ditto, by Sir R. I. Murchison, F.R.S.

Ditto Great Britain, by Professor Geikie, F.R.S.

Ditto Scotland, by " "

Ditto Ireland, by Professor Jukes, F.R.S.

ON HOW WE COME TO KNOW; OR, THE FIRST PRINCIPLES OF THE THEORY OF COGNITION.

BY THOS. P. KIRKMAN, M.A., F.R.S.

1. I HAVE been recently studying the last, and therefore in all probability the best, formal treatise out, on a great and renowned subject. It is entitled *An Exposition and Defence of the Scholastic Philosophy*, by the Rev. Father Kleutgen, a learned Jesuit. The work appeared in German, in four parts, in 1860 and the following years, and it is now before the world in French in four volumes. The first chapter is on "The Principles of the Scholastics about Cognition." In all books that call themselves Science or Philosophy the opening dissertation is the one to be examined sharply for pitfalls and sophisms; and, if the work is what it pretends to be, the first propositions will defy all assailants. If the book, like too many of the class, is mere rhetoric and mock-science, the rigorous reader will not require to look far for muddles and for dunce-traps. When we consider the unequalled renown with which the Scholastic Philosophy has reigned for two thousand years, and the power and learning of those who still teach it in Catholic Universities, we must allow that its doctrines are deserving of some study. All confess that the beginning of knowledge is simple feeling or sensation, the consciousness of mere changes in ourselves, accompanied with pleasure or discomfort. These are varying phases of "I am," but have not shaped themselves into "I can" and "I will," that is, varying states of conscious being, which do not amount to propositions. I do not mean verbal propositions, but what may be called virtual ones. Such, I imagine, are always really made when the

first knowledge of "I can" and "I will" however dimly dawns in us. About how we come to know in the formation of these first elementary propositions, we can perhaps talk something like sense of conjecture; but we can lay down little that is fit to be called science, for this reason, that it is incapable of verification. We cannot repeat the process of our first lessons in our earliest infancy. And I maintain that no propositions are deserving to rank as scientific which cannot be rigorously verified. The grand discovery of Berkeley in his *Theory of Vision* is science, because it can be verified, and is verified whenever by the removal of cataract sight is conferred on the born-blind. I hope, also, that what I have had the honour of saying here, that our will-force is our only force-finder and force-measurer, will be accepted as verifiable science. About the actual first beginning of how we come to know, I hold that we can talk neither science nor sense of any kind, which is an exposition of this *how*. About this *how* of consciousness, simple sensation, memory, and the flash of volition by which I move my limbs, I deny that I either know, or possibly can know, anything beyond the fact as it is. I had the honour of giving you my reasons for this opinion of my ignorance in a previous Paper, when exposing the sophistries of David Hume about this *how*. I will not repeat the argument; for it would be of no use except to those who are likely to ponder it as it stands in the pages of our *Proceedings*. I would rather listen to criticism of the argument by other thinkers.

2. Kleutgen's first dissertation is on Cognition, meaning all knowledge whereby we come to make propositions. There is no restriction whatever of the meaning of Cognition. The first principle is stated in large type thus:—"Cognition is the result of the generation in the knower of an image of the object known, by the concurrence of the knower and of the object."

“In this principle,” says the expositor, “there are two axioms. First, in the knowing subject is engendered an image of the object known; that is to say, the subject who knows puts on a certain resemblance with his object. With merely this general formula before us, it seems very difficult to doubt the truth of the axiom.” I ought to have felt encouraged by that remark; but I was a little discouraged. I said to myself---this is philosophy, not poetry. I will stand no tropes nor tricks in a fundamental theorem. If it be scientific for me to say about my cognition of sunset, or of a cup of tea, that there is engendered in me the knower an image of the sunset or of the cup of tea, is that quite the same thing as to say that I have put on myself a resemblance to the sunset or to the cup of tea? Is the addition of the engendered image to my mental furniture the same thing as a change in my own resemblance? The correct statement of what I have in me, and that of what I am like, is hardly one and the same statement even in rhetoric, much less in an axiom of science. “O,” says the expositor, “I said only a certain resemblance.” I read the words once more. That word *certain* is about the funniest of all the tools of Profundity. I have elsewhere remarked upon its use in a fundamental definition of Kant, that it means exactly *highly uncertain*; and I am wicked enough to repeat in the ears of angry critics that whenever it thus figures in an axiom, or in a definition of philosophy, we have before us what I call a metaphysical mud-pie.

3. I soon saw that my teacher insisted upon his right to speak of my cognition as brought about either by an image formed in me by generation, or by a fresh resemblance put on me by assimilation. In the next paragraph (20) he tries to make me understand the “assimilation or the resemblance of the knower and the object known, which is formed in cognition.” In the following paragraph (21) he affirms that “he

who knows is capable of the knowledge only by being united to the knowable object either by essence or by resemblance. By virtue of this union, cognition springs from the knower and the known as from a single principle." This is, in fact, the enunciation of the second axiom in the first principle which heads this chapter.

I began to suspect here that I saw handled, not a set of scientific terms, but a set of tropes that could be exchanged at pleasure, and from which, doing duty in premisses as scientific terms, a great variety of conclusions might be deduced in the most natural manner possible.

4. To the first axiom laid down in the principle no man can object in a piece of popular rhetoric. My knowledge of many things is so precise in number, measure, and minute detail, and so easily verified, that it may without any harm be said of me that I have in me an image of the object known. But I say that this affirmation of an image of the object, either engendered or otherwise wrought in me, is very far from being accurate science, all slippery tropes being excluded. For nothing can stand as a theorem of exact philosophy which is not capable of verification by an appeal to facts of passive or active experience. There is no ambiguity or uncertainty in my conviction that I know many things; for I can prove my knowledge by laying down a number of clear propositions about things which cannot be denied, but can be rigorously verified in time, place, and number; and that is the only exposition and the only proof of my knowledge that any philosopher can demand of me.

5. But if I choose to assert that there is in me or in my possession, mentally anyhow, an image of the sunset, of a horse, of a river, or of a cup of tea, how am I to set about verifying this, figures of speech being excluded? An image and that which it represents are familiar experiences without tropes and metaphors. I can look first at one and then at the

other. I can place myself between the original object and the likeness, or set them apart before me and judge of the resemblance. But if I place myself in view of the sunset or of my cup of tea, admiring the one or handling the other, what am I doing? I am merely repeating my cognition of the one and of the other. What am I comparing? Simply my present cognition with my memory of previous ones. I cannot place myself between my object and the cognition that I choose to call its image, nor can I set the two apart before me. This impossibility in the attempt at verification is proof that the word image that I have used is a harmless trope, and not a term of science at all.

6. These tropes of my image of the object, and of my union with it by my resemblance, are not the only ones employed by the scholastics and their learned expositor. He continues thus, in the passage quoted above in (2):— “Whatever thing we know, we possess it, in a certain manner in ourselves, and that precisely by our intellect. Now, it is impossible for the intellect to appropriate the object as to its physical being; it can therefore only possess it by imitating it, and by reproducing it in itself, in a manner which corresponds to the nature of the intellect, or by engendering it as it were (*en quelque sorte*) anew.” “The representation whereby a man conceives his own essence is nothing else but a reproduction of that essence engendered in the reason.” How the writer succeeded in the conception of his own essence, or how he found out that he was conceiving exactly that, he does not inform us. But he shows us how theologians teach that the Word is the Image of the Father, by proceeding from Him by the way of intellectual generation.

7. The term *possess*, above introduced, with the decoration “in a certain manner,” is something in rhetoric, but nothing in science, or nothing but a mischievous germ of sophism. Nothing is properly possessed by me which is

equally the possession of others, and of which I cannot divest myself. It is curious to see here how the trope *possess*, by figuring in a premiss, is made to guarantee the more wonderful terms *reproduce* and *engender anew*. What a charming machine we have here for the manufacture of scientific conclusions ! We shall presently see to what sublime results we are led by carding and roving of these terms of *image*, *assimilation*, *union*, *possession*, *appropriation*, *generation*, and *reproduction*. In the next paragraph we read : " Not every resemblance makes a thing into the image of another ; this term *image* is reserved to the resemblance which is formed *with the intention* of imitating or reproducing another thing. Now the resemblance of the knower to the thing known does not consist of necessity in the sameness of essence : if it were so, we could know nothing but what is of the same species with ourselves." He has remarked above in the same page, that things are said to be of the same species which are alike in their essence. " We thus come at the meaning of the scholastics in their affirmation that things are knowable because, besides the real physical being which they possess, they can also have another, an *intentional* being, or we may say an ideal being, in him who knows ; and further, that a principle or agent becomes a knower by receiving, in addition to the being which is his own, also the being of something else." These words are to be taken as quite in literal earnest by the student who seeks to apprehend the full meaning of the first principle before us, and to know how the image is engendered in the knower by the concurrence of the knower and the known. The scientific result is that the thing known acquires a second being, called *intentional*, in the intellect of the knower, while the knower himself acquires and verily possesses by union of essence or resemblance, in addition to his own proper being, the being of the thing known. That appears to be the effect of this generation by concurrence.

8. The climax is to come. I am still quoting: "In order that cognition may take place, it is undoubtedly necessary that the *form* of the object known, that which distinguishes the object, should actually be in the knower; but it is not necessary that it be in him present in the same way as in the thing known. . . . The intellectual image contains what distinguishes things, that is to say, their accidental or substantial *forms*, in a manner different from that in which they are found in the things; in other words, without their material and changing being" (§ 24). Again he says: "Hereby we see at once why things material are in us by cognition in a manner more perfect than that in which they exist in reality; or, as Thomas Aquinas puts it, 'cum in ea [anima] res ipsæ nobilius esse habeant quam in se ipsis.'"—*De Veritale*, q. 15.

"Herein lies the perfection which belongs to the cognitive principle as such; for cognition is possible only on condition that the thing known is in a certain manner in the knower." (§ 31). "The soul is capable of appropriating things by cognition not only as to their phenomena, but what is more, as to their essence, only by virtue of the immutability of its own substance. . . . Hereby we see in what sense the scholastics say with Aristotle that our intellectual nature, that which in us is indestructible and eternal, can become all things. . . . The human soul can by cognition grasp and embrace the perfection of the whole universe" (§ 32). "De anima dicitur, animam esse quodammodo omnia, quia nata est omnia cognoscere." (*De Veritale*, q. 2., a. 2.) "Cognoscendo vero omnia intellectus quodammodo fit omnia, et trahit ad se perfectionem omnium rerum. Hinc est, ut homo præcipue per intellectum sit microcosmus, quia quot species rerum sunt in mundo, tot possunt poni intentionaliter in intellectu."—*Maurus*, quæst. 4.

Wonderful things did those saints and sages with their

quodammodo. The *quodammodo* was their magical wand of universal mastery.

9. How thoroughly in earnest all this is, can be understood only by those who know what the scholastics meant by the *form* of a thing, namely, not the mere shape and figure, but all that bestows on the thing a true substantial and determinate being. The *matter* of a thing they affirmed to have no substance or determination whatever, and to be, by itself and without some determining form, utterly incapable of existing. They allowed matter by itself to have a potential *essence*, but no possible *existence*, *per se*, whatever. They scorned all theories of *atoms*, while they affirmed material things to be substances only by virtue of the union of their matter and their forms. In the transformation of substances by fire and other destroying agencies, they held that the form perished, but not the matter, which merely became instantaneously invested and determined by a new form, thus becoming another substance. But if all form were to be withdrawn from the matter, that forsaken matter would be a *non-ens*, having no existence, but only a mere potentiality, or *posse*. This the scholastics considered to be quite intelligible.

10. Whatever I may think of the use made by the scholastics of the trope *form*, I largely approve of their notions and definitions about matter. They are incomparably more philosophical and free from assumptions and bad logic than the dreams of our materialists about their atoms and their ether.

It cannot be denied that there is sound reason for the resolution which those acute thinkers insisted on making of the objects around us in the cosmos, animate and inanimate, the double resolution, into two factors. These two factors of a body, when we consider the transformations which take place in time, as of grass into beef, and of water and sunshine

into grass, are matter and form. The two factors, when we consider a body as it is at this moment before us, are substance and accident. But my notion of the formless matter and of the underlying substance is not theirs. One thing they seem to have overlooked in their conception of the result of the withdrawal of all form from the formless matter; which is, that the locus in space of the body would remain, a locus of geometrical points, after the complete withdrawal of the force-points, as well as the path in space which had been described up to the time t by the body and its parts, a path described up to the time t by no other body. That *perdurabile* is there forever, and can be retraced by a thinker who is master of the acting forces. Into this I cannot further enter now. I can easily pardon the little boasting of the scholastics about their knowledge of substantial and intelligible forms, for the sake of the sound philosophy which they talk about matter, compared with the doctrine of that matter, of which, with his mother Must-be, so many of our superstitious *savans* are now singing out—"These be thy Gods, O Israel."

I shall not attempt to follow the learned Kleutgen in his further exposition of the wonderful theory of *intelligible forms*, by which we come to know things and to retain our knowledge of them; still less shall I touch the more wonderful theory of Abstraction, whereby, according to the scholastics, we pull off or drag off the forms from the phenomenal objects around us; nor shall I try to shew you what is "*abstrahere formas à phantasmatisibus*."

11. In vain do I search into the mystery of how I came to know. I can make my guesses, but the process will never be unravelled. There was a time when I hung on my mother's breast, little more than a changing sequence of purely passive impressions. As I drained that blissful fountain, I was pleased with the warmth and softness that

cherished the little hand which I knew not was my own. Not less was my delight from the beaming eyes, the wreathed smiles, and graceful ringlets that tossed in love and ecstasy over me. And when my fingers, in their random gladness, chanced to clasp upon the ringlet, I was pleased with the charming image of my own white arm, as it was lost or revealed in that flood of flowing hair, and I felt with a pleasure like my mother's rapture my own strength, as I tugged at the silken coil. But all was chaos—there was yet no unity—there was yet no virtual proposition. On another occasion, as I rushed to the same joy and resigned myself to the same heaven, the memory of previous delights stood steady there ; and as the beautiful tresses hung over me again, tempting my baby hand, I virtually said for the first time, "I know that lock, I know that I can grasp it, and I will." I put forth a conscious volition. I succeeded in the effort. It burst upon me that the dusky sheen and the straining softness were both in one ; and my guardian angel clapped his hands to see that I had learned the first lesson of unity and reality in God's world of mercies and of wonders. Such meditations may be worth something as part of my religion ; but they are not science.

12. It will now be pretty plain to my hearers that my object in reading this little Paper, is not to display my knowledge, but my ignorance, about how we come to know, and to give very good reasons for thinking that those deep scholastics were about as ignorant as myself, notwithstanding their wonderful persuasion that they knew, and that they were true microcosms embracing by cognition in themselves the being and the essence of all things.

We have most of us felt humbled, when we have heard propounded that sublimest mystery of ontology and metaphysics, that knowing is being, that knowing and being at bottom are one. Which of us has not said, How deep, how

vast, that is! I wish I could get round that, or get across that, somehow. Well, there is nothing to get across but a shallow wash of scholastic trope and rhetoric. I cannot see, nor will I allow till somebody helps me to see it, that this profound identity of knowing and being is anything but stuff and nonsense in the philosophy of the finite. Cognition, the sages tell us, is by virtue of an engendered image; the image is assimilation, the assimilation is union and possession, and true reproduction of the thing known as a part of our own living being; so that "*animus quadammodo fit omnia*"; "*anima quadammodo est omnia*." The knower *quadammodo* becomes what he knows; knowing is *quadammodo* being.

13. I have satisfied myself, and I hope I have convinced you, that the great scholastics, with their pompous pretensions to know how we know, expressed of their own insight by their tropes, and called up in the minds of their pupils, not a whit more wisdom than every one of us expresses and conveys by, I feel, I perceive, I know. Why should I be ashamed to confess my utter ignorance of *how* I come to know, and of every *how* that can be propounded about consciousness, volition, memory, and intellectual cognition? In these matters, allow me to say in all matters of science, my ignorance is in truth the grandest part of my knowledge. We have sometimes laughed, it may be, at the applications of the proverb, *omne ignotum pro magnifico*. Are you sure that we have not sometimes laughed for want of thought? If I may confess the honest truth, I say that my *ignotum* is my *magnificentissimum*. To my soul there comes an inspiration a thousand times more sublime from my contemplation of my ignorance, than from my review of all that I know. That inspiration wells up from my admiring, undying, and adoring faith; my exultation and my glorying in Him who does know; in Him so near and so gracious to you and me, who

not only knows it but can do it, nay, does it, is doing it before my eyes every moment, with all the beauty of science and order, with perfect power and perfect ease, and with most benignant purpose for us all; the God in whom we live, and move, and have our being.

Even of things that should be less complex and unsearchable than the deep inward facts of consciousness, even of the commonest outward things, my ignorance is wonderful. When I am looking at a chickweed, or peering through my poor little lens at a hair upon its stem, I ask myself, What are the human cleverness and hammering in all the complexity of the Queen's dockyards, compared with the swift science and power expended on the vast manifold of that living hair? It would be a sad downfall for me, when I am enjoying the boundless prospect of my ignorance of what is there going on in my sight and out of it, if some angel were to undertake to teach me how to answer every question that my science could ask upon it. Hardly less a downfall would it be, if I were to learn that there is somewhere in heaven a Seraph who is unable to ask himself a scientific question about that hair which he does not know how to solve. For at present I do not believe that the biggest Biologist among them all up there has yet made himself quite master of the scientific theory of one single cell.

But, lo! our sublunatic philosophers — they have unravelled all life and thought down to the first structural unit, the structureless gelatinous protoplasm! There are men enough out now, and quite in the fashion with their brooms on their shoulders, as resolute as Mrs. Partington with her mop, who mean to make an end of this ignorance, and to sweep it all away. Wait a little, while Dr. Mustbeso puts the finishing touch to his evolution — just wait for the end of his gory and gloating vivisections, as hopeful as hell, and of his analyses by disintegration and undifferentiation of his infinite invisi-

ble — only wait, and then you shall see — how much there is left of your Cosmos to conquer.

We have all joined, and justly joined, in the censure of certain priests of the olden time, and of certain priestlings of our own day, for their over-admiration of a venerable maxim. I shall conclude with that maxim, which has in it a nobler and more uplifting truth than we have been willing to confess in it. I venture, although aware how easily what I say can be misrepresented, to finish with this affirmation, that for you, for me, and for all the archangels of God, Ignorance is the mother of Devotion.

ON THE FIRST DEFINITION OF THE
SCHOLASTIC PHILOSOPHY.

BY THOS. P. KIRKMAN, M.A., F.R.S.

IN inviting you to look more closely into the foundations and beginnings of Philosophy, I feel sure that some of you, members as you are of a learned society, will stiffly decline to imitate the exploit of the most successful genius on record in this planet. I fear that few of you are ambitious to emulate that heroic man, whose praise is in far more than all the churches, whose praise is in all the households, nay, in all the nurseries, and whose renown would be extolled by one here, if he had the opportunity, "with all his might and main," though not without an ancient grotesque of parable, in every hall of science, among men or angels. Who was that great man? Let me beg of you not to smile, because I am in real earnest:

"There was a man of Thessaly,
And he was wondrous wise,
He jumped into a bramble-bush,
And scratched out both his eyes.
And when he saw his eyes were out,
With all his might and main,
He leapt into a quickset-hedge,
And scratched them in again."

That is the great model which I would set before young philosophy. It was little credit to him to scratch his eyes out: the wondrous wisdom lay in scratching them in again.

The beginnings of Philosophy, about Being, Consciousness, Cause, Will, Law, Matter, Force, Soul, Power, Responsibility—these real beginnings are to hundreds, who

can talk logic well when they get out to sea, all one thicket of cruel thorns. Again and again it has happened to me in conversation with men of acute minds, to see them recoil from the bramble-bush, while, at a distance from it, they were both loud and learned. I put a little question about a meaning for a fundamental word that shall be free from tropes and quibbles, about a definite proposition for a starting-point, about a couple of steps of solid foot-hold, and my friend waves that loftily away. He knows all that; he is tired of that; he knows it to be waste of time and words, and bosh unfathomable. He insists on talking where there is plenty of room; and there is always plenty of that for men who never trouble themselves about first principles.

And thus we may go on, from quibbling sire to muddling son, for another century or two. But yet, I think, not forever. Let me tell you why I think so. Science has already scratched both her eyes in again, in one terrible thorn-bush, and her vision is clear forever. The dynamical brambles were, not two centuries ago, quite as full of blindness and despair as certain thickets that are now horrid with the prickles and tangles of thousands of years. The notions which philosophers had about mere motion, and about the way to conceive and to express fundamental truths concerning equilibrium, resisting and resultant forces, about attractions and impacts, momenta and velocities, rotations and orbits, with their simplest compositions, resolutions, and variations, the notions of deep thinkers, as to the right way into these matters, were as full of confusion and contradiction as are any questions of the present day touching the beginnings of Philosophy. These were thorns impenetrable till yesterday, when the mathematicians worked out what I believe to be by far the greatest achievement of human intellect, the six fundamental differential equations for the behaviour and position of any system of moving and interacting masses in

space, and shewed how to translate them into feet and seconds, correct at any time t , to as many decimal places as you please. How was this victory obtained? By returning again and again to the problem; by asking, at the starting-point of greatest simplicity, questions free of ambiguity; by refusing every answer that was not stripped of may-be's, must-be's, metaphors, and vague generalities; by writing what was given and what was sought in words and symbols, having each one clear meaning, and one only; by constructing a fixed sequence of plain propositions, about which dispute is impossible, and which the boys in our schools are now made to understand and exemplify with the simplest lines and numbers. This was all done by men who, instead of shewing superior light by keeping their precious noses out of the bramble-bush, jumped into it, and in and in again with all their might and main, till they had scratched in all their eyes.

If to some of you this sounds like trifling out of place, I hope there are a few present who regret with me the neglect—I will not say the contempt—into which the study of fundamental philosophy has fallen in these days of money-making and of microscopical and most desultory physical research. I confess myself to be greatly disappointed when I try to compare our enormous and costly accumulation of disjointed facts, in all departments of physics and physiology, with the marvellously small amount—since gravitation and two or three other things were discovered—of scientific insight into the close connexions and laws of the changes, apart from mechanical and economical successes—the small amount of insight, I say, which is either obtained or hopefully looked for, under clear answers expected, or even questions definitely proposed.

I see crowds of good heads busy with mere observations, obtained by rifling sea and land and sky, by dissection of the

dead and vivisection of the tortured living, observations with vast gulphs of ignorance between them, which certain Newtons and Harveys of the future are to have the honour of reducing and compacting into something fit to be called science. I cannot help wishing that a few of these good heads would reconsider the determination which they seem to have made, to have nothing to do with what they call metaphysics, but which, so far as it is science written, I prefer to call *prophysics*, the first foundation of thought and certainty for the complete soul of man.

Some one may here ask, Would you have us plunge again into that bog, more offensive and barren than even the chaos of sectarian theology—the wilderness of philosophy so-called—and metaphysics? I answer, I do not recommend quite a plunge. But I think it not unreasonable to wish that we could resume so much respect for our own understandings as to say, We are competent to decide, with familiar and habitual insight, what are the first two or three questions that ought to be asked, and how to ask them in terms free from tropes and ambiguities, at the beginning of Philosophy. We are competent for something better than displaying what a hatful we know about what Plato and Aristotle said; of what Des Cartes and Spinoza said; of what Malebranche, Leibnitz, Locke, Berkeley, Hume, and Kant said. We are fit to form and to maintain a conviction of our own, at least, about the first axioms immovable that ought to be written down by thinkers, and to decide whether the first two or three questions that we say should be asked, are or are not, can be or cannot be, answered in propositions of accurate science, to be recorded and referred to forever, like the first theorems of Euclid.

If there are any here who say that it is not worth their while as thinkers to come to any decided conviction about the first steps in philosophy, I must content myself with

addressing those who happen to approve of what I have tried to do, in laying down, as so many have done before, the Cartesian axiom, "I am, and I know that I am, thinking," as the one fundamental proposition of science out of which all our knowledge of the universe logically flows.

If you be in hearty earnest in laying this down with me, you feel that it is an important thing to do, and that it is a matter which no consistent reasoner can dismiss thenceforth from his attention. If it be really the first, it must be a very fertile principle, and it is a worthy occupation for the accurate thinker to satisfy himself of the manner how everything of certainty, at the beginning of science, follows from it.

In my treatise on *Philosophy without Assumptions*, I have endeavoured to shew how, out of that radical dichotomy which we all verify in consciousness, of purely passive sensation on the one hand, and of the active utterance of will-force in thought and deed on the other, certain important first theorems flow with demonstration. I am daily more and more convinced, for not one word have I yet heard or read that pretends to assault that conviction with more than empty negations, that those theorems are as rigorously proved as they are important.

I shall go over none of the ground covered in my book. I invite you to consider one or two points not sufficiently handled there.

If we desire to continue our study of the beginning of philosophy, we cannot neglect this question—How are we to fix the definition of a host of words of which we cannot avoid the use at the beginning?

The first term in our fundamental proposition is I, the ego so renowned in speculation. Are we to define that? You smile at the idea of debating the definition of ego; and your smile would become a laugh, if I insisted on displaying my defining power there. Suppose, now, that I have some-

thing wise to say about egoity. *Egoitas, egoitatis, egoitati*, has cut in all its cases a famous figure in philosophy. Should not this be defined? Is it not a grand long word ending in -ity? So it is; but I think I had best not try to instruct you by my definition of it; and I should laugh with you at the wiseacre who should set about defining either his egoity or mine.

But a grin is no argument. We ought not to be content with laughing. We must, as philosophers, give a sound reason for our merriment. And the reason is worth stating; for in the hands of one who has the presence of mind to use it, it is a dangerous weapon against a good deal of false philosophy. It lies in the truth of the following propositions:—

1. When we have determined and agreed together which is the first fundamental proposition in philosophy, we are bound to define, when required, every fresh term that we employ, which is not confessedly a term of that first proposition.

2. It is an absurdity and a self-contradiction for us to attempt to define any term of that fundamental proposition, or of any proposition which we are agreed to use as an equivalent, or as a safe, exact, and unambiguous circumlocution, for that first and fundamental one.

To prove this absurdity, we have only to consider what is the intention of a definition in science, that is, of one which is not a mere verbal synonym—a mere dictionary equivalent. The intention is to lead the student to the knowledge of the thing defined, through some notion or proposition which is plainer, easier, and nearer to him, than the first proposition to be laid down containing the term defined.

When we have agreed as accurate thinkers that the first, absolutely the first, proposition of certain knowledge that we can possibly write down in the order of science, is “I am,

and I know that I am, a thinker," most of us can see that we stultify ourselves, and revoke the absolute primacy of our fundamental truth, if we set about the definition of any term in it; for that, in fact, is affirming that there is a position to be laid down in our knowledge which is antecedent to the very first, and nearer to us than the nearest, namely, the position through which and from which we complete the definition. The only scientific exploit which we can possibly perform is a vicious circle, which ends where it began.

I am not at all sure that everybody will see the force of this; for what is there in all philosophy so delicious and seductive as a good gallop on a good donkey on a good old road, round a nice large hill? You are always going right on; you run no risk of losing yourself; for you know what you are coming to.

There is a number of equivalents and circumlocutions for the fundamental proposition, "I am, and I know that I am, thinking," where thinking stands for the act of intelligence of the moment at which I lay down the proposition. It is most important to bear in mind that this fundamental fact, so affirmed in the full import of "I am," is not what I laid down yesterday, or even five minutes ago; but the fact known to my consciousness at this moment, verifiable by the appeal to consciousness at this moment, and incapable of verification in any other way. Philosophy, which I am to think through, to assent to as the truth known to me, which I have to state in propositions, and to maintain and defend by sound logic, this is always a train of reasoned thought, which, for fresh examination and verification, can begin neither in me nor in you but at this moment. In every phase and tone of my reasoning soul, I have to posit as the starting-point this immovable certainty, that I surely know myself to be the thinker of this thought, whether it be right or wrong; and out of that, with the help of memory,

and of that will which I know I can put forth for comparison and verification, out of that alone flows the whole train of reasoning. Sometimes, in my merely passive states of consciousness, this "I am," which I am certain that I know, is little more than purely listless sensation; but, generally, when I am in quest of precious truth, I am in action, my will is at work, and "I am" rises to "I can and I will;" and whenever I am debating with a fellow-man, there towers over all the majestic presence of "I ought," and of that I know that I and he are thinking, with the clearest conviction of what is due from each of us to his brother and to truth.

I will not here go into the question whether or no this "I ought" is, when thinker speaks to thinker, an element inseparable from the fundamental proposition with which alone a formulated Philosophy can begin, and out of which alone it can logically flow. Here is matter for earnest discussion. I think it will be found by us, on further examination, that the attempt either to doubt or to define moral obligation and responsibility is no less absurd and self-contradictory than the attempt to define egoity, personality, or personal identity, will, mind, or the terms being, knowing, and thinking.

Nor will I attempt to enumerate the equivalents and the admissible dilutions and circumlocutions that may be written for the only fundamental "I am, and I know that I am." Here, too, is matter for useful discussion. It is not a trifling occupation for us to determine accurately the import of the first word which the immortal Des Cartes pronounced to that world of deriding scholastics, *cogito*. There are plenty of acute debaters who will not accept the starting-position of Des Cartes, nor be bound to its enormous consequences; for I say they are enormous, and utterly crushing to whole hosts of fashionable philosophers, before the eyes of every

sound logician who understands the laughable geometry of the vicious circle. Don't ask one of those gentlemen to write down a definite truth which he holds and is prepared to defend as the absolutely first position of all reasoning thought; you will be taking a live eel by the tail. There are no men more clever in their sallies about first principles in philosophy than those who hold no principle at all; if your demand for clearness is too close, they cry out *Metaphysics*, and are ready to deride alike the sceptical industry which looks for a settled definite principle and the logical loyalty which stands by it. By principle, I mean a clear fundamental proposition.

One admissible equivalent there is for the Cartesian first principle. It is this—I am, and I know that I am, a living soul. We can all agree, I presume, that by the word soul we mean a conscious being endowed with will, reason, and conscience. It is one thing to be so agreed, and another to undertake to state what a soul is, in a definition fit to take its place in science. I decline to define the soul, or a soul, or my soul, all the same thing in a general definition, for it amounts to neither more nor less than defining the egoity of me-the-thinker.

But, you may remark, it is one of your propositions that you have a soul, and that is not explicitly comprised in your fundamental principle. If that be so, I am bound both to define a soul and to prove that I have one. But I am not aware that I have any such thing, nor can I affirm that I have it, without a figure of speech, drawn from my relation to what is not myself. I no more have a soul than I have a self. I am understood well enough when I talk of myself or of my soul. But neither self nor soul expresses what I have; it expresses what I am. The truth without a trope is, I am myself, I am my soul, or I-the-thinker am a soul. Equally do I refuse to allow, as a pro-

position of rigorous science, that I have a being. I know that noble utterance: "In Him we live and move and have our being." It is an authorised text, but not quite authorised by Paul's Greek; the Greek is ἐν αὐτῷ γὰρ ζῶμεν, καὶ κινούμεθα καὶ ἔσμεν.

I am a being; but only by one of those baneful tropes that we have to weed out of the beginnings of philosophy can I-the-thinker affirm that I have a being. An amazing amount of metaphysics would disappear if the phrase, to have a being, (*esse habere, quidditatem habere*) were blotted out. Under ENS, I read in my Lexicon, "Simpliciter dicitur res, quod habet *esse* ratum et firmum in natura; et dicitur hoc modo, accepto nomine rei, secundum quod habet quidditatem, vel essentiam quamdam; ens vero, secundum quod habet *esse*." That is, we call it *ens*, because it has an *esse*; we call it *res*, a something, because it has a somethingity, because it has a quiddity or a certain essence. I refuse to define my soul; you may define it if you can, and if you can do it without circle or metaphor, I will study your definition. I am bound to define my body, if I talk science about it; that I can do by finding it and shewing you how to find it. But my body is something different from me-the-thinker. I have a body: there is no figure of speech in that.

These remarks introduce the little that I have to say about the foundations of the Scholastic Philosophy. It has been difficult for me to bring myself to speak on a theme so repulsive to most English ears. Grant me what indulgence you can. I hold in my hand a fair and very instructive sample of it, which, because of its living interest, will afford you more pleasure, or at least inflict less annoyance, than anything which I could myself have selected. This is a syllabus of a long Paper, entitled "The Soul before and after Death." It is marked private, and printed for private circulation among the members of a

philosophical society of the metropolis, previous to the reading of the Paper by one whom I shall not name, a man of great learning, who is familiar with all the philosophies. His part in the argument, in which the keenest wits of all the schools, theistic and atheistic, contend without reserve and without *odium*, is by express stipulation, as he himself has informed me, to appear clad only in the armour and wielding only the weapons of the old scholastic philosophers : and perhaps no man in England is more qualified than he for that championship. You will therefore kindly bear in mind that whatever there may be to praise or to censure belongs not to him, but to those ancient doctors from whose tomes every proposition of the Paper is extracted. I shall read to you only the short metaphysical opening. The bulk of it is a noble and victorious array of psychological and moral proofs, before which all the negations, circles, and sophisms of the fashionable matter-and-must-be philosophy are, to my captious and sceptical faculties, as chaff before the wind. I have the permission of the gentleman who wrote this syllabus to make use of it here, and he has read every word of this Paper, from which I should have expunged all allusion to his, if he had desired it. He did not desire it ; but remarks that I am imperilling my reputation as a philosopher. I can say that, like him, I care much more for the diffusion of truth than for renown in philosophy. And we have little chance of much truth of lasting importance to us, until we have learned and agreed how to talk sense, if not science, about our own souls. The truth on such a topic has a price "above rubies," even if we reach it through thorns and bleeding blunders.

I proceed to read every word of the metaphysical portion.

"1. If I am asked for a definition of the soul, I answer, 'Est principium per quod homo sensitivus est, cogitat et vult ;' it is the principle by which man perceives, thinks, and

acts; or again, more simply, 'It is the principle of life, and of the vital acts of thought and will.'

"2. If I am asked for a definition of life, I say it is 'Activitas qua Ens seipsum movet.' By motion in man is intended not only physical, but intellectual, moral, and mental.

"3. If any one shall ask for a metaphysical definition of principle, I answer, it is 'that which produces anything.' 'Principium est id quod rationem continet, cur illud sit, ejus dicitur principium.'

"The Principle of a thing is that which contains the reason why the thing is, of which it is called the Principle. The idea of a Principle is that out of which anything proceeds, as a tree from a root, or a stalk from a grain of wheat. And yet the word 'principle' is not a metaphor of similitude, but of proportion: as a root to a tree, so a principle to its product. A root and a principle may be dissimilar in everything but the one point of production, yet the analogy or ratio of proportion holds good. The mistaking of analogies for metaphors or images is the source of endless confusion. It is like believing Providence to be an eye."

That is all. It may have been expanded in the actual delivery of the address. No doubt it was. The Latin and the formal definitions and explications are all in inverted commas. They are most probably copied word for word from Thomas Aquinas himself, the great St. Thomas, as the scholastic manuals call him.

You will at once confess that all this sounds logical and very profound. I hope you will none of you despair of mastering it, if you just try, as we go over it bit by bit. I am quite sure it is not too deep for any of us. Let us all try, taking one thing at once. First let me observe that we have no right to charge these writers with nonsense, when they attempt to define *life* and *soul*. For they do not allow

the Cartesian starting-point to be the right one. All the scholastics affirm that Des Cartes made quite a wrong beginning. For me or for you, at that starting-point, to define life and soul, would be gross self-contradiction, as I have already shewn.

We need not dwell on this Latin definition of life—"activitas qua ens seipsum movet" in the second sentence. But it is an interesting example of the defining power of those ancient gentlemen. The student is supposed desirous to know what life is, and learns this: "Life is the activity by which a being moves itself." He is in fact advised to run about till he finds a being in motion; he is to satisfy himself as best he can that self-movement is the cause of the motion; he is taught to call that by the name of activity—nothing but a word in *-ivity* would answer—and then to say, Now I know that life is the activity whereby a being moves itself. I wonder whether it ever came into the student's head that he was himself alive and active, and thereby master of more knowledge of life than he could learn by the definitions of doctors.

The scholastic soul is what we are studying. In the definition here given of soul, comes the word *principle*. "The soul is the principle of life, and of the vital acts of thought and will." Very properly we next have *principle* defined for us. First thus: "It is that which produces anything;" next thus: "The principle is that which contains the reason why the thing is; rationem continet cur illud sit, cujus dicitur principium." Then the scientific formula, "as the root to the tree, so is the principle to the product," which, as to its form of words, is properly called "an analogy of proportion."

If the scholastic doctors were here, I should say, Gentlemen, I perceive you are talking about me; what you call my soul seems to be not me-the-soul, but the principle and root

of me. I am one of the men perceiving, thinking, willing, acting, of whose being, thought, and action you scientifically understand the finite producing principle which you call the soul. I shall make it, if you please, a personal matter, a lesson to me about myself. That is my only possible way into it. We must settle first whether what you call my soul and my metaphysical principle is what I know as my conscious soul; if not, you will kindly help me to find for myself, without mistake, as really belonging to me, what you in your philosophy call my soul; and if you fail to do that, I shall beg to know how you came to discover so much in the science of the finite about a soul of mine which I have failed hitherto to observe, and which you cannot help me to find for myself.

Suppose that little difficulty got over. I listen to them: they define my soul as my principle, the principle of my life and of my vital acts of thought and will. That is of no use to me till I know what *principle* is. They are very scrupulous logicians, and they proceed to inform me of that. First we have, copied, I am sure, from a page in which it stands as a sufficient, though very compendious, answer, "that which produces anything." The whole sentence is, paragraph 8— "If any one shall ask for a metaphysical definition of principle, I answer, it is (then inverted commas) 'that which produces anything.'" Well answered, say I; for it is a most metaphysical definition that will produce anything.

I break my unlucky shins first over the word "produces." The only use of the word, free from trope of rhetoric, is in geometry, when we produce a line. From a given point, in a given direction, we have a line to continue; that is the only notion of *producere* that is free from vagueness. We can talk correctly enough for common life, of the land producing crops, the sea producing fishes, the shopman producing his stock on hand, the manufacturer producing his wares and goods, the toothache producing pain, the frost producing chilblains,

the factor producing a product, the orator, the trumpet, or the bonnet producing a sensation, wealth producing idleness—and so on, I know not how far. You may call that running away with a subject. Why don't I stick to my text?

We read, "The idea of Principle (there is a capital P) is that out of which anything proceeds, as a tree from a root, or a stalk from a grain of wheat." "As a root to a tree, so a principle to its product." We are to ponder *proceed* and *product*; *proceeding* and being *produced*. The tree proceeds from the root, as part of an aggregate in space; the stalk proceeds from the grain, by a countless succession of changes in time. At any rate, seeing that the one point of production is the thing to consider, you cannot deny that the root produces the tree, and is therefore by definition its principle; nor that the grain produces the stalk, and is therefore by definition its principle. Very true; but the root produces the stalk as often as the root the tree: so by definition the stalk has two principles, the root and the grain. Further, as production is the one point to be studied, the stalk produces the grain as often as the grain produces the stalk, in the usual course of nature. So the grain is either product or principle, just as we please. And, in fact, the tree produces the root, just as much as the root produces the tree; for the sap digested by the tree in the sunbeams deposits every fibre both of tree and root. It is all beautifully circular.

If the scholastics were here, I should not have it all my own way. The debate about principle and product would last exactly a week, with more and more acute distinction on their part every hour. The end would infallibly be that the principle is verily that which produces anything; and that production—proper production—is that which is due to a true principle. And with that everybody would be satisfied, except a few captious people like you and me.

The most important feature in this specimen of metaphysics is the ring of scientific rigour in it. There can be no possible doubt about mathematical truth. Without paying any regard to my punctilious ignorance of what they are talking about, they proceed to clench all by an analogy of proportion. In old mathematical books the Rule-of-Three-statement, as A is to B so is C to D, or as A is to B so is C to the answer, is often called an analogy; and correctly, for analogy is the Greek for proportion. We have all heard of the analogies of Napier in spherics. Brinkley, in his *Astronomy*, always calls them analogies, and writes them as such, with the formal dots of the Rule of Three. It is laid down here: "As the root to the tree, so is the principle to the product." This is not offered explicitly as a truth of geometry or arithmetic; but it is an analogy or ratio of proportion, which, as we are informed, holds good. Well, if it be science in earnest, I may write it down on the black board thus:— $R : T :: P : p$; R over T equals big P over little p, which affirms neither more nor less than this, that R the root is to T the tree as big P the principle is to little p the product, the exact assertion before us.

Now, I myself am a case of the product. I-the-conscious-thinker am little p: I may put K for that: then we read that my sought metaphysical principle P_x is to me, Kirkman, as the root is to the tree. If this be a ratio of proportion, the unknown P ought to be got at easily in terms of the known realities—T, R, and K. K is plainly given, and as to the relation or ratio of R to T, we ought to be able to get that somehow out of a gooseberry tree. But they stop us there. We are not talking of your vulgar fractions, say they, we are talking metaphysics. The ratio of proportion in what cannot be counted is not numerical. Why, then, say I, do you condescend to employ the formula of vulgar arithmetic? What right have you to call your profundity about

Tree and Root, and Principle and Product, an analogy and ratio of proportion? They reply, If we choose to express our sublime truth in the form of an analogy of proportion, we can speak of it as such; for it is such, by its very form. Then they resolutely proceed to shut my mouth by this remark: "A root and a principle may be dissimilar in everything but the one point of production; yet the analogy or ratio of proportion holds good." Ugly customers are these old sages.

What can I do? I think I should beat a retreat under cover of this final illustration. Can you deny that 3 is the next to 2, in ascending proximity? No, they reply. Can you deny that 1878 is the next in ascending proximity to 1877? Of course not. Then I maintain that as 2 is to 3, so is 1877 to 1878. That is my analogy of proportion. They beg to test this analogy by the Rule of Three. I rejoin, I am not talking about the Rule of Three, nor of any other rule of arithmetic; I am talking only of ascending proximity, which, in itself, is a thing that cannot be halved, or doubled, or counted at all. I choose to write down my truth as an analogy of proportion, and I have a right to call it what it is by its very form. And, further, I maintain this thesis: a single figure and a row of figures may be dissimilar in everything but the one point of ascending proximity, yet the analogy or ratio of proportion holds good.

I have not come here to poke fun at metaphysics; but I defy any man to answer fine-spun logic like this, except by retorting it. You can never fairly retort truth so as to make it look like falsehood. I submit that it is of some importance that this, even if it be nonsense, should be answered, if we are in earnest about having, and affirming before all men, a fixed starting-point in the philosophy which we talk about ourselves, inasmuch as we have here before us the work of no trifle; we have here, in the best scientific

shape in which one of the foremost living scholastics in Europe can put it, the way in which those thinkers profess to begin, who loudly refuse to admit that Des Cartes made the right beginning. We can all grant that this ratio of proportion is a clever and ingenious attempt to escape from the fatal charge of *definition by metaphor*.

It seems to lay down more than what is intended. The scholastic writer means to affirm that the principle produces the product as really and truly as the root the tree. That makes the analogy; in that there is nothing to amend. We are referred to the study of production of tree by root. But whatever our success may be there, I cannot see how I am to get at the real finite scientific principle of which I-the-thinker am the product. It is a useful common-place in logic, that a definition is of little or no use for a train of reasoned thought, so long as we have no proof of the existence of the thing defined. And the thing here defined is my finite metaphysical principle of life, thought, and will,—something different from this me-the-thinker, which is the product; for my life, my thought, and my will is the product.

There may be sense in this analogy of root and tree, when once it is known or granted that this finite principle P of me-the-thinker exists. But until I am satisfied of its real existence within the reach of my faculties, I will not go one step with you in search of analogies to explain my dependence on this P. I say to these doctors, Place me in a real relation, of which I can see that I-the-thinker am one term, and this finite principle is the other. Thus only can I get at this P. Your philosophy begins with the unproved assumption that this P exists within reach of my science; and it begins nowhere else. It is not presented as philosophy without assumptions; and if it is not that, I say it is sham philosophy, in spite of angelic doctors. This is worth saying, if it be true; and if it be not true, the error is

important enough to deserve confutation, unless all philosophy be alike a sham.

When we ask, What is the precise question which these scholastics are trying to answer, we obtain from what is before us the reply—Nothing but this, What is the principle of man's thought, life, and will? This becomes, when principle is explained, What is that which produces my life, thought, and will? or, What is that something in science which contains the reason why I am a living soul endowed with thought and will?

Here you are ready to remark, They mean the proper efficient cause—the cause which really produces the thing, and is the complete reason why. The answer to their question is, The cause “who worketh all in all,” the Creator and Preserver of all. You are greatly mistaken as to their meaning, if you think so. This *principium* is not The Great First Cause. It is something finite which contains the reason why, quod rationem continet cur illud sit cujus dicitur principium. I am afraid that continet is but a trope. Of the causation due to the Author of the Universe they say the noblest things, and think as we do. They repeat it again and again, that if the creating and preserving energy of that First Cause were suspended for a moment, the cosmos would fall back into nothing. You cannot offend these philosophers more than by telling them that they are pondering the impenetrable secret of the Divine Causation, when they are spinning their metaphysics; and you are lucky if they do not throw at your head that ugly missile, Pantheism, which they all maintain—and I suspect they are in the right there—to be merely a fine name for Atheism. A wonderful array have they to shew you of causes and causations. I have at home a *Lexicon Peripateticum*, a dictionary of scholastic distinctiones et effata. Under CAUSA I find, all in capital letters in full, the following:—Causa externa; Causa

interna ; C. finalis ; C. efficiens ; C. exemplaris ; C. formalis ; C. ex qua ; C. in qua ; C. circa quam ; C. prima ; C. secunda ; C. princeps ; C. instrumentaria ; C. univoca ; C. equivocata ; C. necessaria ; C. libera ; C. universalis ; C. particularis ; C. physica ; C. moralis ; C. adæquata ; C. inadæquata ; C. proxima ; C. remota ; C. per se ; C. per accidens. Under every one of these heads, and more, if you like, they will write you a long and most logical treatise, that will do you such a world of good.

Their causing *principium* of me and you is a fact which finite science can handle in definitions and demonstrations. It is something on this side of theology, but on the other side of nature, life and consciousness ; on the other side of what science can find in the field open to observation, experiment and memory. This latter is a very humble field, mere physics and psychology. Their sublime field is *μετὰ τὰ φυσικά* ; it is on the farther side of physics ; it is metaphysics, and a long way on this side of theology. They seem to think that nothing can save us from Pantheism but their big buffer of metaphysics between physics and theology.

I confess that I have not to go far to find myself in theology. And most of us, when we get outside the known facts of time, space, force, life and consciousness, soon lose ourselves in the unsearchable, and begin to talk in tones of wonder and awe about the Infinite Cause of all. Not so the scholastics. There they are in their own domain, in comparison of whose permanent and grand realities the phenomenal field of physiologists, chemists, astronomers, and the like, is but an ever-fleeting sequence of accidental shadows. Theirs is the domain of being *per se*, the root and ground of all that firmly and really is to men or to angels ; and it is filled with potentialities, causations, actualities and principles like this which we are studying, to be got at only by penetrating right through to the other side ; filled, too, with

no end of wonders about ideas, entities, essences, receptivities, activities, substances in the sense of substratums, inherences and substantial forms. Marvels to behold are their tomes. I suppose that three hundred years ago the volumes of the scholastic philosophy exceeded in number those of law, letters, and all the sciences, if we except theology and what went for history.

It is not without reason that all our literature for centuries has been strewn with disdainful and resentful allusions to this imperial and tyrannical old science. Of course nothing ever goes far enough in this little planet, unless it goes too far. The panic, I hope, has reached its limit. The air is now musical with the voices of men brain-smitten, either from experience or from heredity, with a terror of that old horse Scholasticism and of his bold rider Sacerdotalism; men who are prophesying, some with more or less reserve, and others with no reserve at all, this venerable strain—that there exist neither Gods nor God, except Matter and his mother Must-be. These are the gentlemen described in the parable, who have jumped into the bramble-bush, and scratched out both their eyes. Before long, they will see that their eyes are out; then taking courage, and resolutely working onwards their feeble and unfinished scepticism to a logical end, they will leap into the quickset-hedge, and scratch them in again.

Some may remark that it is but slaying the slain, to expose the pretensions of this old philosophy to search the unsearchable. I am in doubt whether one scholar in ten millions believes it, besides the Professors in Roman Catholic Colleges, and the confiding young men whom they train with such skill and mastery. If I may judge from what I read in the manuals written by those professors, they do not all quite believe it themselves.

They are yet a power in the world, those Roman Catholic Doctors and their pupils, and a power, I believe, for future

good. Fortunately, they are not bound to think it sinful to exercise their own judgment on the philosophy which the competent among them are so well taught. The future good will arise when a greater proportion of them have used their liberty of speculation. Let their school-philosophy be only well aired in public, and the rents and moth-holes in it well shown up, and there will remain very little that is perilous about those young gentlemen. They only laugh at those who attack them with texts. They are taught, if they have the capacity for it, to use their brains in matters of philosophy with a dialectic precision and readiness, with an all-roundness of research, and with a power of refined abstraction, in handling the difficult cobwebs of their schools, such as are, so far as I can discover, utterly unknown in our Protestant lecture-halls and manuals of clerical training.

This assertion should not be made here without some proof. Let one proof suffice, of which you will all judge. How many Protestant clergymen are there, conformists or nonconformists, who know anything about the philosophy of Boscovich? Are there three in a hundred of them who, when they came to be ordained, had ever even heard his name? In all my training in letters, science and theology, I never heard it. Now no Roman Catholic candidate for orders can go, as a student of ordinary industry, through a manual of their philosophy, or hear a single course of lectures on it, without learning something definite on the notions of Boscovich. No doubt they can forget what they learn as fast as our worthy selves. Not faster, I am sure. I do not believe that there are two dozen Protestant divines in all Lancashire who, if ever this Paper comes before them in print, will have the faintest appetite for its perusal. Their philosophical innocence will be fortunate if it escapes a convulsion at the title.

Scholastic philosophy is not all metaphysics. Far from it. It is in some departments an arsenal of the noblest logic

and truth. Notwithstanding what I have said against the mere metaphysics of it, I should like to be permitted here, without any pretence to play the prophet, for I may be quite in error, to place on record my persuasion—on which, however, I implore you to say not a word in the discussion that may follow, because it can lead to nothing, and can do no good—my personal persuasion, Broad Churchman as I am, that whenever the grand movement comes that shall uplift the Church of the future to the full reconciliation of Faith, Philosophy, and Science, it will come, not from our matter-and-must-be doctors and vivisectors, nor from our scandalous and wrangling sectarianisms, whether fat or lean, but from some liberal Pope and his Professors. I say that there lies hid, exactly where it ought to lie, a skilful flexibility and a scientific power of adaptation, which can yet bring about all that. But again I beg you to let it pass.

I could have despatched the whole of this matter, if my object had not been to give a lesson to younger men in philosophy, and to invite the attention of more good heads to these enquiries, in one word, metaphor, which some of you have probably noted. If the relation of proportion of this real principle to its product is in science that of root to tree, then, if we may think at all, we must logically infer that, as the root is verily the root of the tree, so the principle is verily the root of the product; as also that the root is verily the principle of the tree. If not, where is the sameness of the relation? Thus my unknown metaphysical principle is defined to me as the root of me-the-thinker, and that is all the definition that the analogy supplies. Principle is defined by *root*. My principle is simply my root. This is definition by a metaphor; and, in fact, this word *radix* is almost as often in the mouths of these philosophers as are their everlasting

tropes, *substare* and *substantia*. Our champion confesses the metaphor. I think I should have left that to be found out by my opponent. His words are conscientiously copied from his authorities, "and the word principle is not a metaphor of similitude, but of proportion." The ancient scholastic who invented that neat distinction was satisfied that there was something so highly scientific in the term *proportion* as quite to neutralise the mischief of *metaphor*. But as the proportion turns out to be not measurable proportion, admitting of less and more, which is the only kind known to any science, it is but trope upon trope after all.

If a definition by a metaphor be presented to me as an instrument of science, I shall put it in the fire, even if an angel has written it. This may be called captious; but if the builders of our glorious mathematics of motion had not been a hundred times more captious word-whippers and punctilious hair-splitters than I am, we should never have had a true astronomy. Why should it be impossible to agree about a rigorously exact beginning of philosophy?

I have entitled this Paper "The First Definition of the Scholastic Philosophy." I am not sure that it is not a misnomer. In none of their books have I been able to find an answer to my question, Where is the defined starting-point, or what is the fundamental proposition, or simplest combination of such propositions? But as I am most nearly concerned with what they have to teach me about myself, and most likely to understand their first lesson to me about me-the-thinker, I shall continue to affirm, until some one better informed takes the trouble to answer my question more correctly, that I have been here handling the first definition of their philosophy. If any one maintains that they have no first, or that there needs be no first, that man bears witness that their logic is all circular, and therefore

all vicious, logic. Most thankful shall I be to sit and listen to any one who can instruct me. There ought to come more light from somewhere in this Great Britain. Can no little circle of Englishmen exchange thoughts in earnest on these topics except in one room in one city—London? Why should not we, in this second city of the empire, have a Prophysical Section of our Literary and Philosophical Society?

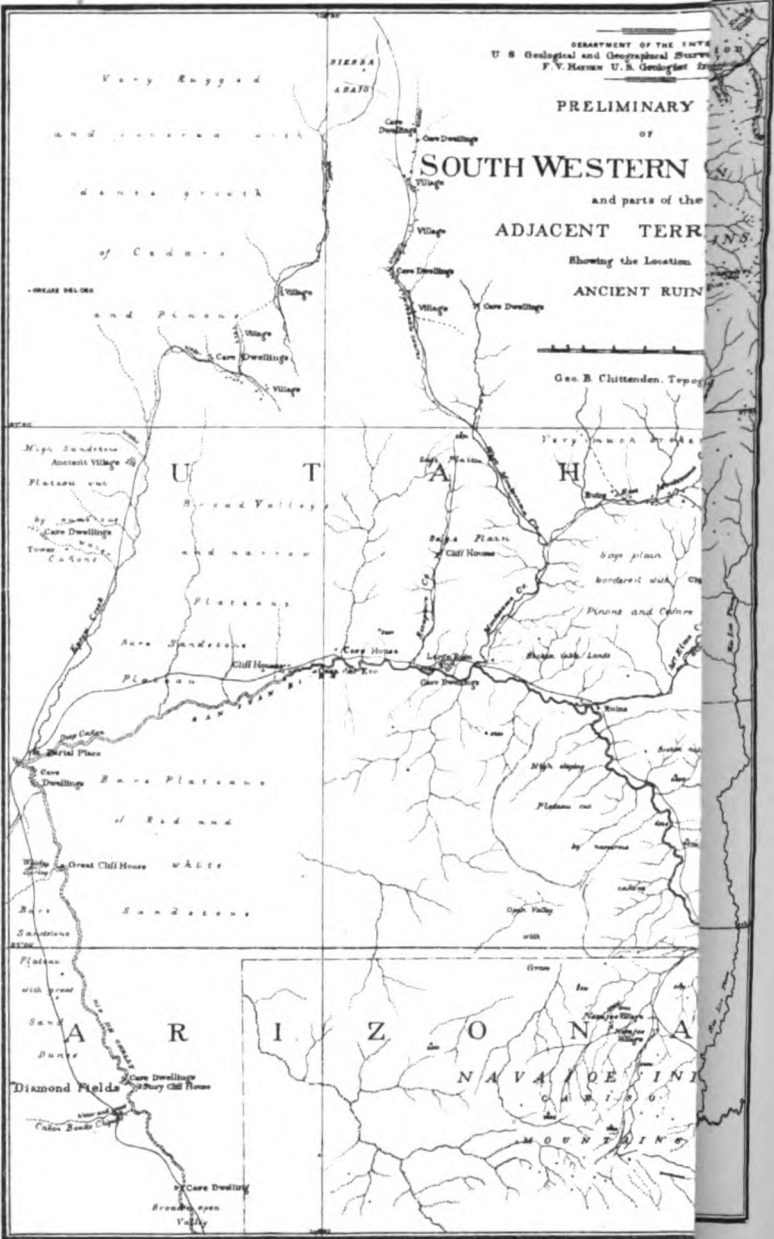

DEPARTMENT OF THE INTERIOR
 U. S. Geological and Geographical Survey
 F. V. Hayden, U. S. Geologist in Charge

PRELIMINARY
 OF
SOUTH WESTERN
 and parts of the
ADJACENT TERRITORIES
 Showing the Location
 of
ANCIENT RUINS

Geo. B. Chittenden, Topog.

Very rugged
 and covered with
 dense growth
 of Cedars
 - great numbers
 and Pinons

High Sandstone
 Ancient Village of
 Plateau cut
 by some of
 Cave Dwellings
 Town
 Cañon

Utah

Very narrow
 and narrow
 Plateaus
 Ana Sandstone
 Plateau
 Cliff House
 Cave Dwellings
 Mesa Plateau
 of Red and
 White
 Great Cliff House
 walled
 Sandstone
 Plateau
 with roof

Very narrow
 mesa plain
 bordered with
 Pinons and Cedars
 Sandstone
 Cliff House
 Mesa Plateau
 High sloping
 Plateau cut
 by narrow
 cañon
 with
 mesa

Arizona

Very narrow
 mesa plain
 bordered with
 Pinons and Cedars
 Sandstone
 Cliff House
 Mesa Plateau
 High sloping
 Plateau cut
 by narrow
 cañon
 with
 mesa

San
 Dunce
 Diamond Fields
 Cave Dwellings
 Cliff House
 Cañon Bend

Arizona

Very narrow
 mesa plain
 bordered with
 Pinons and Cedars
 Sandstone
 Cliff House
 Mesa Plateau
 High sloping
 Plateau cut
 by narrow
 cañon
 with
 mesa

New Mexico

Very narrow
 mesa plain
 bordered with
 Pinons and Cedars
 Sandstone
 Cliff House
 Mesa Plateau
 High sloping
 Plateau cut
 by narrow
 cañon
 with
 mesa

ON THE CLIFF-HOUSES AND ANTIQUITIES OF
SOUTH-WESTERN COLORADO AND NEW
MEXICO.

By ALFRED MORGAN.

ON a previous occasion, I had the pleasure of sketching, though very briefly, the history and progress of the United States' Geological and Geographical Survey of the Territories; and I propose this evening giving the Society a short account of the remarkable archæological discoveries that have been made under the auspices of this Survey, in a region that was but little known until 1874, when one of Dr. Hayden's surveying parties, under the direction of Mr. W. H. Jackson, made a tour into the south-western portion of Colorado, for the purpose of examining and obtaining photographs of the interesting ruins of the dwellings of a long-forgotten race, which are very numerous in that region. By the kindness of Dr. Hayden, I am able to illustrate this Paper with a series of photographs which will bring the peculiarities of the structures to which I shall refer vividly before you. Mr. Jackson's narrative, which is contained in the volume of the *Annual Report* of the Survey for that year, is of very great interest, and awakened a lively curiosity as to the builders of the houses he described. In 1875, a special *Bulletin* was published by the Survey, containing papers by Messrs. W. H. Holmes, W. H. Jackson, and E. A. Barber, on the archæology and antiquities of the region, and by Dr. Bessels, on the anthropology, etc., with other notes. It is to these publications that I am indebted for the information that I wish to bring before the Society this evening.

Mr. Jackson's explorations were made along the course of the Rio Mancos, one of the western tributaries of the San Juan, which originates in two forks flowing from among the western foot-hills of the La Plata Mountains. The Rio Mancos, from the junction of these streams, flows in a south-westerly direction, through fertile and beautiful valleys, to a plateau which is known as the Mesa Verde, through which it has cut a remarkable cañon. The Mesa Verde is a somewhat irregular table-land, comprising an area of about seven hundred square miles, and is formed by a great series of nearly horizontal sedimentary strata, of which the surrounding country has been denuded. This series of strata consists in the upper part of massive sandstones, in the middle portion of alternating sandstones and shales, and in the lower division of eight hundred feet or more of shales, clays, etc. These softer beds are, when once exposed to erosive agencies, carried away with great rapidity, and, as a consequence, the firmer rocks are undermined and break away, leaving vertical cliffs; and, where soft and hard beds alternate, a series of benches or terraces, with intervening slopes, is formed. A cañon formed under these conditions will consist of a narrow, irregular river-bottom, long, steep slopes of *débris* rising like the arms of a letter V from this, then a succession of steeps and slopes, culminating above in cliffs. The cañon of the Rio Mancos is nearly thirty miles in length, and ranges from one to two thousand feet in depth. It seems to have been a favourite resort of the cliff-building people, and traces of their occupation are found everywhere—along the river-course, in the cliffs, and on the plateau above.

Mr. Jackson thus describes the discovery of one of the most remarkable cliff-houses of the Rio Mancos:—"Our camp for the night was among the stunted piñons and cedars immediately at the foot of the escarpment of the

Mesa, its steep slopes and perpendicular faces rising nearly one thousand feet above us. Quantities of broken pottery were strewn across the trail to the edge of the stream, and, as ruins of some sort generally followed, close attention was paid to the surroundings; but with the exception of a small square inclosure, indicating possibly a grave, nothing was found to reward our search. Just as the sun was sinking behind the western walls of the cañon, one of the party descried, far up the cliff, what appeared to be a house, with a square wall, and apertures indicating two storeys, but so far up that only the very sharpest eyes could define anything satisfactorily. We had no field-glass with the party, and to this fact is probably due the failure to detect others during the day, for there is no doubt that ruins exist throughout the entire length of the cañon, far above, and out of the way of ordinary observation. Cedars and pines also grow thickly along the ledges upon which the houses are built, hiding completely anything behind them. All that we did find were built of the same materials as the cliffs themselves, with but few, and then only the smallest, apertures towards the cañon; the surface being dressed very smoothly, and showing no lines of masonry, it was only on the very closest inspection that the house could be separated from the cliff.

“The discovery of this house, so far above anything heretofore seen, inspired us immediately with the ambition to scale the heights and explore it, although night was drawing on fast, and darkness would probably overtake us among the precipices, with a chance of being detained there all night. All hands started up, but only two persevered to the end. The first five hundred feet of ascent were over a long, steep slope of *débris*, overgrown with cedar; then came alternate perpendiculars and slopes. Immediately below the house was a nearly perpendicular face of one hundred feet, that puzzled us for awhile, and which we were only able to

surmount by finding cracks and crevices into which fingers and toes could be inserted. From the little ledges occasionally found, and by stepping upon each other's shoulders, and grasping tufts of *yucca*, one would draw himself up to another shelf, and then, by letting down a stick of cedar, or a hand, would assist the other. Soon we reached a slope, smooth and steep, in which there had been cut a series of steps, now weathered away into a series of undulating hummocks, by which it was easy to ascend, and without them almost an impossibility. Another short steep slope, and we were under the ledge upon which the house was built. It was getting quite dark, so we delayed no longer than to assure ourselves that it was all we hoped for, and to prospect a way up when we should return the next morning with our photographic outfit."*

This house, which is represented in Plate I., stands upon a narrow ledge, and is overhung by the massive strata which form the upper portion of the escarpment. The ledge is about ten feet in width, and of some twenty feet in length. The height of the overhanging strata, from the surface of the ledge or terrace, is about fifteen feet. Perched up in its little crevice, like a swallow's nest, the house consists of two storeys, having a total height of twelve feet, and leaving a space of two or three feet between the top of the walls and the roofing rock. Whether any other roof had ever existed, the explorers could not determine. The ground plan showed a front room about six feet by nine feet in dimensions, and at the back of it two smaller rooms, the face of the rock forming their back walls. These apartments were each about five feet by seven feet, and the room at the left-hand side projects beyond the wall of the front one. Remains of cedar beams were found, which had formerly divided the structure into two storeys. The lower front room has two

* Report U. S. Geol. and Geog. Survey, for 1874, p. 372.

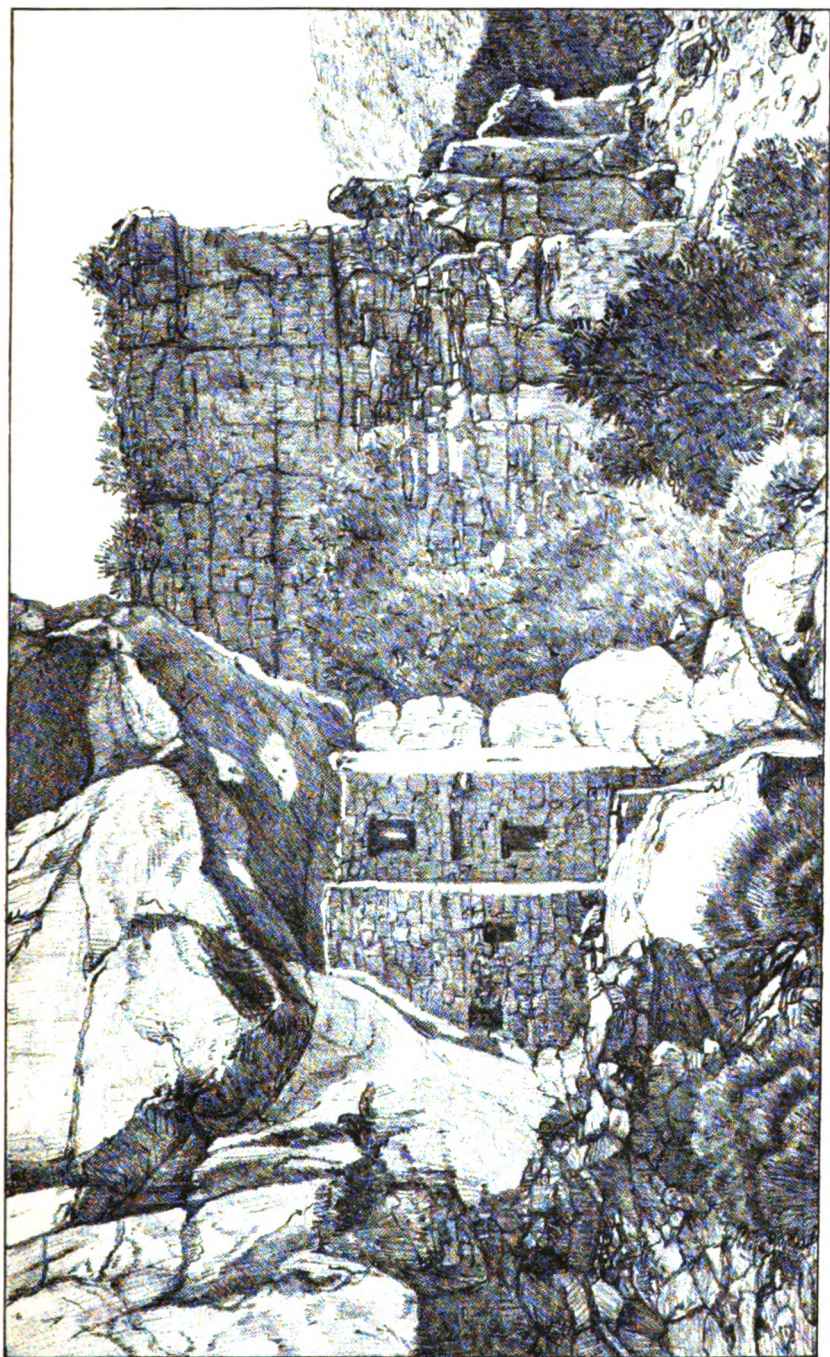

PLATE I.

apertures, one opening on the elevated esplanade, and serving as a door, though only measuring twenty by thirty inches, and the other, a very small outlook near the ceiling, which would command a view of the cañon below. In the upper storey is a window similarly situated to the door, and of like size and shape. The upper lintel of this window was formed of small cedar beams.

The entire construction of this little human eyrie displays wonderful perseverance, ingenuity, and some taste. Perpendiculars and angles are carefully regarded. About the corners of the windows great care has been taken; the mortar is compact and hard, resembling lime, but cracking all over. All the apertures are small, resembling the door already described. The walls of both the upper and the lower front rooms were plastered with an adobe cement of about an eighth of an inch in thickness, and coloured a deep maroon-red, with a white band eight inches wide running around floor, sides, and ceiling. Remains of similar houses were found in all directions, and there is little doubt that a large population once lived upon these ledges of rock.

Numerous side cañons ramify in all directions into the Mesa, and along these come great freshets during the rainy season, producing deep "arroyos," and strewing the surface with the *débris* of rocks, cedar, sage-bush, and cacti. Mr. Jackson, speaking of this phenomenon, says:—"About the mouth of Coal-cañon the whole surface of the 'wash' was covered with lumps of fine-looking bituminous coal, as though a thousand coal-carts had traversed the district with their tail-boards out."

Mr. Jackson's party then traversed the Mesa in an easterly direction till they arrived at Aztec springs, near the El Late Mountains; but finding no water there, were not able to stay to examine in detail the massive ruins in the vicinity. The *débris* of these forms a great mound which,

though overgrown with artimisia, still indicates the original rectangular plan of the structure, with its circular inclosure in the centre. These ruins were again visited in 1875 by Mr. Holmes and his party, and are very fully described by him in the *Bulletin* of the Survey.

Plate II. is the ground plan of one of the most interesting of the Rio Mancos cliff-houses. The line from *a* to *b* is the front or precipice line of the niche-floor. From this the broken cliffs and slopes reach down to the river. The deepest portion of the recess is at *c*; and the dividing walls are all built to the rock. The most remarkable feature is the round room, or *estufa*, which, as is generally the case, is in a large rectangular apartment. This singular chamber had, without doubt, been constructed for a very special purpose. As Mr. Holmes remarks:—"The superstitions of the builders seem to have been so exacting in this matter, that even when driven to the extremity of building and dwelling in the midst of these desolate cliffs, an inclosure of this form could not be dispensed with; a circular *estufa* had to be constructed at whatever cost of labour or convenience." The entrance at *d* was so constructed that a person entering this inclosure would have to crawl through a tube-like passage of nearly twenty feet in length, and only twenty-two inches high by thirty inches in width. All this attests the desire of the builders to render the *estufa* as sacred as possible, and to guard against the possibility of intrusion. The other apartments do not require any special mention; they were quite plain and empty, and in passing from one room to another, the inhabitants had to climb up and over the walls and pass through apertures near the ceiling, the walls apparently having not been built up to the over-hanging rock.

The entire district in which the ruins are found is of about six thousand square miles in extent, and lies chiefly in the territory of Colorado, but includes portions of the

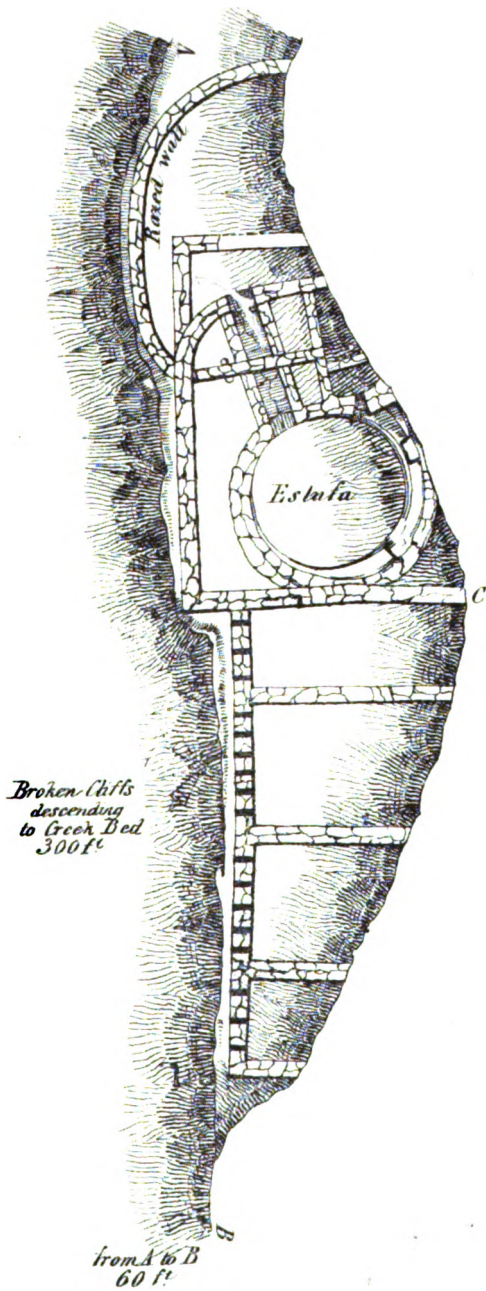

contiguous territories of New Mexico, Utah, and Arizona. The entire region is on the Pacific slope, and is included in the great drainage system of the Rio San Juan—a tributary of the Colorado of the West. The surface geology is chiefly cretaceous, and is cut up in all directions by deep and rugged canons.

A reference to the map which accompanies this Paper, and which is a photographic reduction of that issued by the Survey, will show that the country consists of a great plateau-region, and extends in a westerly and southerly direction from the base of the San Juan Mountains. Numerous streams, having their sources in the western slope of the Rocky Mountains, have cut their way, forming long cañoned valleys through the nearly horizontal strata. In the greater part of the region there is little moisture apart from the streams, and, as a consequence, vegetation is very sparse, and the general aspect of the country is semi-desert. Yet there is abundant evidence that it at one time supported a numerous population; and there is scarcely a square mile in the six thousand miles of territory examined that does not furnish evidence of occupation by a race in every way superior to the nomadic savages who now roam over the country.

It has been thought that climatic conditions have altered since the date of this ancient occupation, for the dry and barren condition of the country, as it at present exists, would render it incapable of supporting even a moderate population. But, without discussing whether any such change has occurred, it is to be noticed that the majority of the ruins occur in the immediate vicinity of streams which yield a plentiful supply of water at all seasons.

All along the stream courses there are grass-covered meadows and alluvial soils, affording a large area of rich tillable land.

Most of the ruins are stone structures, but there is

evidence of other material having been used in the construction of the villages, etc., in the lower lying parts of the region. The remains may be classed under three heads:—

1. Lowland or agricultural settlements.
2. Cave dwellings.
3. Cliff-houses or fortresses.

Those dwellings that are comprised within the first group are usually found on fertile spots, and would appear to have been built with reference to convenience of water supply, etc., and not with a view to defence.

Those constituting the second class are built in excavations in the low bluffs of the middle cretaceous shales of the district, and with a view to security in case of attack.

The cliff-houses, the third group of structure, were intended to be places of secure refuge and defence, and were built in the most inaccessible places; and—unless we may suppose that some water may, at that period, have found its way from the level of the surface of the plateau in descending streams, and have been utilised by the dwellers in their elevated habitations—were far removed from the source of water supply.

The lowland ruins are the remains of such agricultural settlements as would be built by any peaceful and unmolested people. The cave-dwellings may not have been the usual dwelling-places of the people, but were used on these occasions when it was necessary to be on guard against invasion. The cliff-houses would serve as the last resort of a desperate people, who were determined to hold to the very last, and we can readily imagine that such fortress-dwellings would enable the invaded families to defy for a considerable time the attacking forces that assembled below them.

In form, the parallelogram and circle predominate, and a considerable degree of architectural skill is displayed. Where the conformation of the ground permits, the squares are

perfect squares, and the circles are perfect circles. A great part of the ordinary structures are square, while attached to each group, and sometimes without indications of contiguous buildings, are circular structures, resembling towers. These are the most pretentious edifices, being sometimes as much as forty feet in diameter, and in many cases having double or triple walls. They are solidly built of hewn stone, dressed on the outside to the curve, neatly jointed and laid in mortar.

The space between the outer walls is invariably divided by heavy partition-walls into a number of apartments, while a circular depression, or *estufa*, occupies the centre of the inclosure. *Estufa* is a Spanish word, and signifies "sweat-house" or "council-house."

It seems evident from the extraordinary forms of the towers that they were not intended to be either dwellings or defensive structures; and they are generally regarded as the edifices in which the religious observances of the people were conducted. If, as is generally supposed, the ancient races of these regions worshipped the sun—the eternal fire—the circle may be taken to symbolise their deity. And the occurrence of one or more of these circular inclosures in every settlement would seem to be at once explained.

But it is more difficult to explain the significance of the double and triple walls with the numerous compartments between. In the inhabited Pueblos of to-day, there are underground rooms, mostly circular, used as council-chambers, and also for the celebration of the mysterious rites of their religion. Lieutenant Simpson describes such chambers as being common in all the ruined cities of New Mexico.*

It is stated by Squier and Davis, in *Ancient Monuments of the Mississippi Valley*, that in Mexico the sacred

* *Journal Amer. Geographical Society*, vol. v., etc.

inclosures were used for defensive purposes when necessary, and it certainly seems probable that these curious structures served the double purposes of temples and fortresses, and the intermural apartments were, perhaps, the cells of the priests, or the chambers in which sacred or valuable property was placed for security.

The smaller single-walled towers which are scattered at intervals along the canons were probably watch-towers. The cave dwellings were made by digging irregular cavities in the faces of the bluffs or cliffs of friable rock, and then walling up the front, leaving only a small doorway and an occasional window. The cliff-houses conform in shape to the floor of the niche or shelf on which they are built, and the manner in which they are attached to the cliffs is truly marvellous. Their construction has cost an immense amount of labour, all the stone and mortar of which they are built having been brought for hundreds of feet up most precipitous places. In general aspect they present a more modern appearance than do the valley or cave remains, and may, perhaps, be regarded as the monuments of the closing period of a long era of occupation.

Of works of art, other than architectural, that might assist in elucidating the history of the singular people who dwelt in these regions, but meagre discoveries have been made, though it is probable that future explorations will be fully rewarded. A small number of arrow-heads, stone implements, ornaments, and articles of fictile manufacture, that may be fairly regarded as the work of the builders, have been collected. There is no evidence whatever that metals were used. The remains of pottery are very abundant, and would seem to indicate that the ancient tribes of the San Juan produced fictile fabrics superior to those of the town-building tribes of the present day. There is, however, great similarity between the modern and the ancient work, both in

material and execution, and the difference observed is only what might be expected as the result of centuries of degeneration. Mr. Holmes found fragments of bowls, cups, jugs, pitchers, urns, and vases, in wonderful profusion and almost infinite variety. The material used is generally a fine clay, tempered with sand or pulverised shells. The modelling was done with the hand, and no implement whatever appears to have been used except for the production of surface markings, &c.; the thickness of the ware varies from one-eighth to half an inch. Most of the pottery found has been baked and glazed.

These shattered remains of fictile art that are so abundant in all parts of the region are of great interest, as they indicate that the wonderful people who fashioned them had attained to a high degree of artistic culture. That they inhabited the country at a period antecedent to the date of the Spanish Conquest is all that can be positively affirmed of them, and the question whether they had come within the influence of European civilisation cannot yet be answered.

The most striking peculiarity of the pottery is the regular and hard glazing. In some instances it is rather opaque, whitish, and covers the surface in a thick layer; while in others it is perfectly transparent. The colouring matter used in the production of the patterns was, perhaps, charcoal, but no accurate analysis has yet been made.

Dr. Emil Bessels, from his examination of the skulls and bones brought from these ruins, concludes that it was the practice of these ancient people to compress the skulls of their children in infancy, and makes some very interesting remarks on the subject. He infers that if such deformations are practised, there is always a guiding idea, either emanating from æsthetical feelings, or with some practical

purpose. For instance, among the ancient Peruvians the flattened skulls were considered a sign of aristocracy and high breeding; while, in other cases, the skulls of children have been deformed in early life in order to produce a straight line of profile.

“That the idea of the beautiful was developed to an uncommon extent among the inhabitants of the ruins, is attested by the fact that the fragments of pottery found show simple but tasteful ornamentation, and that great regularity prevails in the construction of their buildings, and that other portions of their handiwork would gratify our own æsthetical feelings.”*

As symmetry prevails in all their work, it is only natural to suppose that the love of it led to the practice of deformation of the crania of their children. Wherever this is the custom, the mother of the child performs the operation with the utmost care, in order to produce the conventional shape, and on one occasion, when Dr. Bessels examined about two hundred flat heads, he found very few that were unsymmetrical. It would appear that the people were in the habit of strapping their children against cradle-boards, as a great many modern Indians do, and hence resulted the flattening of the occiput.

Major Powell remarks that the different Indian tribes he is familiar with keep their children strapped to the cradle-board for one and a half to two years.

Numerous hieroglyphics were observed, both engraved and painted, on the cliffs. A great number of burial-places were noted, which, generally overgrown by piñons and cedars, usually occupy the summits of high ridges and promontories, and are still marked by slabs of sandstone, set on edge and arranged in circles and parallelograms. But that it was not the invariable custom to bury the dead in such localities is

* Dr. Emil Bessels, *Bulletin*, Vol. 2 p. 60.

proved by the frequent discovery of human remains in the arroyos, or deep washes of the valleys.

The question—May any one of the existing tribes of Indians be regarded as the lineal descendants of the ancient people whose work we have been discussing? would seem to admit of an affirmative answer. And the present Pueblos are thought to be the direct descendants of the ancient inhabitants of Southern Colorado and New Mexico, although there are no very definite traditions existing among them that this is so. The conclusion is arrived at from the fact that the mode of constructing houses practised by the Pueblos does not differ materially from that of our ancient architects. The modifications that are observed are such as may readily be explained by the altered conditions of living and modern influence. The dome-like structures of the Peruvians and Eskimos are alone of their class in America.

Another evidence is afforded by the pottery of the Pueblos, all of which is fashioned in the same designs, except that the ancient ware is more carefully made and shows more artistic talent.

It has been thought that in the Moquis of Arizona we may recognise the descendants of these people, and the tribe cherish the tradition that they have descended from the builders of these interesting dwellings, but they retain scarcely a vestige of the civilisation which the remains attest to have existed, and it would seem most probable that in the Pueblos we see the children of the race, the record of whose existence had well nigh been obliterated. But, not to pursue this enquiry further; in the ruins, etc., we have a testimony of the existence of an ancient civilisation in America, and an indication of another centre from which its influence has radiated. We have had opened out before us a new field for anthropological enquiry and criticism, and

it is to be hoped that such investigation will ere long be energetically undertaken.

* * I present to the Society the Map and the Plates that accompany this Paper. The former has been photographically reduced from Mr. Chittenden's Map, and Plate I. was sketched by Mrs. Morgan from the Survey Photograph.

SKETCH OF THE ORIGIN AND PROGRESS OF THE UNITED STATES GEOLOGICAL AND GEOGRA- PHICAL SURVEY OF THE TERRITORIES.

By ALFRED MORGAN.

THE Survey, the operations of which I wish to bring before the notice of the Society this evening, has not yet completed the first decade of its existence ; but, during the short period in which it has pursued its investigations, it has accumulated, as the result of untiring energy and well-directed zeal, a rich fund of information, and has published reports, etc., which have awakened a deep interest, not only in the United States, but also in England and on the Continent of Europe. The excellent *Monographs* and other publications, so admirably printed and illustrated, and which are distributed on a scale of the most open-handed liberality to societies and institutions in all parts of the world, and to large numbers of scientific workers besides, form quite an *embarras des richesses*, from which it is difficult to select without invidiousness.

The Survey is under the direction of my esteemed correspondent, Professor F. V. Hayden, and may be said to have first taken form in 1867, when the territory of Nebraska was united to the Federal Union as a state. On that occasion Congress voted the sum of five thousand dollars, the unexpended balance of the legislative appropriation, for the purpose of a geological survey of the western portion of the new state, and requested Dr. Hayden to take charge of the expedition. In the following year a like sum was voted by Congress, and the work of the Survey was carried into Wyoming. In both these years the work was carried on under the auspices of the General Land Office, but in 1869 the Survey was placed

under the supervision of the Secretary of the Interior, and received its present form. It then commenced a reconnaissance of the Rocky Mountain region, and published much valuable information — geological, mineralogical, agricultural, etc. The Congressional grant was increased in 1869, and still further in 1870, when the area explored comprised a belt of country in Wyoming Territory, along the line of the Union Pacific Railroad. The Report for the latter year includes papers on the geology, natural history, meteorology, agriculture, and natural resources of the region. It has also special reports on palæontology, and presents, in a volume of five hundred and eleven pages, with woodcuts, etc, the first of the series of *Annual Reports* which have since then regularly appeared. The result of the work of the three previous years was published in a single volume.

In 1871 the explorations were carried on in the wonderland of the Continent. The Yellowstone country, with its lake and falls, its geysers and crystalline deposits, was surveyed. The results of this year's work were of the very widest interest, and descriptions were published in America and Europe. So great was the wonder and interest that was aroused, that in the next year's session of Congress it was enacted that the region that had been explored should be set apart as a "National Park" for the everlasting benefit and enjoyment of the people. The Report for the year contains five hundred and thirty-eight pages, with maps, plates, and figures, and is an exceedingly valuable contribution to geology, botany, zoology, and the kindred sciences.

In 1872, the corps of the Survey was divided into two parties, each provided with a geologist, topographer, meteorologist, naturalists, assistants, collectors, etc. The area of exploration for the one party was, as in 1871, about the headwaters of the Yellowstone, Gallatin, and Madison Rivers; and for the other division, the Snake River region.

It was discovered that the Teton Mountains were misplaced by so much as thirty miles distance in all existing maps of the country. The work of the year formed the basis of two geological maps, which I bring before your notice this evening. The Report for this year has eight hundred and forty-four pages, and, like the others of the series, contains many elaborate papers on special subjects. It is illustrated with nearly ninety plates, maps, sections, etc.

The Report for 1873 contains seven hundred and eighteen pages, and is devoted to Colorado. It is equal to the others in interest and value. Subsequent Reports have not yet reached England.

In 1871, Dr. Hayden began to carry on a geographical survey in association with a geological one, and it has been found eminently useful thus to bring the geologist and topographer to act in concert. Existing maps were so inaccurate that they were of little or no use. The system of topographical work until then pursued was that in general use in army surveys, *i.e.*, the reconnaissance of the line of march with the country in sight from it, controlled by courses and distances, arrived at by means of compass and odometer, with the supervising check of the sextant. In 1872 the system of control was improved by the addition of a running system of triangulation, which, in conjunction with the observations for latitude, were used in correcting the work. The character of the work done in these two years, embracing an area of eighteen thousand square miles in Wyoming, Idaho, and Montana, is among the best that has been accomplished.

In 1873, when the survey of Colorado was commenced, it was found necessary to inaugurate a system of primary triangulation, in order to fix a number of points with accuracy, which might serve as the basis of future topographical work. The first important step was to find a suitable surface for the accurate measurement of a base-line, and Mr.

Gardner ultimately selected a spot to the east of Denver, where a tangent of the Kansas Pacific Railroad possessed the requisite conditions. The base is a little over six miles long, and was measured with a steel tape of 100 feet in length, having a spring balance attached, by which the tape was stretched with a tension of sixteen pounds. The temperature was taken every five minutes, and the entire work was twice gone over. The base was levelled and duly corrected for irregularities and temperature. "All the angles of the triangles were repeatedly observed, and the quality of the work was determined by the test whether the three observed angles, when corrected for spherical excess, sum up to 180° . That by which they vary from 180° is an error. The mean error in the primary triangles of Colorado is only $10\cdot3''$. The angles are observed with an eight-inch circle, graduated to $10''$ and reading easily to $5''$. The triangles are from thirty to seventy miles on a side, according to the nature of the ground. The trigonometric stations are situated some eight miles apart, on the most suitable altitudes. From these, other points are determined, and the topography carefully sketched, both with respect to its drainage, horizontal contour, and profile. From these surveys topographical maps are made, on a scale of two miles to an inch, shewing the form of the country in horizontal contour lines, two hundred feet apart in elevation. From these maps all the physical features of the country are easily deduced. The area covered was over twelve thousand square miles in extent."

In 1874 a second base was measured in St. Louis Valley, and an equally good expansion was made over an area of about ten thousand square miles. Connection is established with the work of the United States Coast Survey whenever it is possible.

In 1875 and 1876 the work was extended so as to cover all Colorado west of the 105th meridian, besides small portions of New Mexico, Arizona, and Utah, in all about seventy thousand square miles.

In the history of the Survey just sketched there are three periods :—

The first comprehends the years 1867 and 1868, when the work consisted in the collection of geological facts and specimens.

The second extends from 1869 to 1872, when observations on the material resources and natural history of the areas surveyed received more careful and extended study.

The third period dates from 1873, and was marked by the thorough reorganisation of the Survey. The important relations of topography and geology were then recognised, and the work so arranged as to receive mutual benefit in each department. At the same time, observations continue to be made in all departments of natural history, archæology, and the ethnology of the Indian tribes, etc.

The publications of the Survey consist of :—

Annual Reports, 8vo.

Miscellaneous Publications, 8vo.

The Bulletin, 8vo.

Monographs, 4to.

Maps and Sections.

(i.) The *Annual Reports* are written in a popular style, and contain excellent maps and illustrations. I have referred to them so fully that I need only call your attention to the series on the table.

(ii.) The *Miscellaneous Publications* consist of lists of elevations, catalogues, synopses, etc. The largest of the series is a volume entitled, *The Birds of the North-West*, by Dr. Elliot Cones, in which every known species is fully described.

(iii.) *The Bulletin* is designed to give immediate publicity to any remarkable discovery that it is thought desirable to make known before the ordinary *Reports* or *Monographs* appear. It forms an annual volume. Archæology has a prominent place assigned to it, and the description of the ruins so abundant in the remarkable region of South-Western Colorado, etc., give a particular interest to this series of publications.

(iv.) The *Monographs* or *Quarto Reports* are very elaborate works, and treat of special subjects. Those that have appeared up to the present time are :—

The Acrididæ of North America, by Professor Cyrus Thomas.

The Extinct Vertebrata of the West, by Professor Joseph Leidy.

The Cretaceous Flora, by Professor Lesquereux.

The Cretaceous Vertebrata, by Professor E. D. Cope.

The Fossil Invertebrata of the Western Territories, by F. B. Meek.

The Geometrid Moths, by A. S. Packard, jun.

In this magnificent quarto series of publications, in which the results of original and exhaustive research are embodied, it will be seen that natural history receives special attention. One of the volumes, Cyrus Thomas' "Revision of the *Acrididæ*," is a valuable contribution to science in a country where insect pests are so destructive. Packard's splendid monograph of the Geometrid Moths, which constitute a very numerous family, has received the highest praise. The author thinks that one thousand species exist in North America alone.

Among the publications that are announced are the *Annual Reports*, in continuation of the series, and *Monographs on the Vertebrate Palæontology of the Eocene Formations of the West*, by E. D. Cope; *On the Vertebrate Palæontology of*

the Miocene Formations of the West, by E. D. Cope; *On the Fossil Flora of the Lignitic Tertiary Formations of the Western Territories*, by Leo Lesquereux; three volumes of contributions to the geology of Montana, Wyoming, etc., with woodcuts, sections, maps, and over a hundred photographs and plates; and on the fossil insects of North America.

Much discussion has taken place, and still continues, as to the true horizon of several important geological formations of the West. The eminent collaborators of the Survey are not by any means unanimous in the opinions they form. The difficulty of correlation with an European standard is one which may be expected to recur as geological and palæontological observations become more extended. The evolutional tide of organic development does not appear to have advanced at the same *rate* in all parts of the world, and in the West it would appear that a development of plant life was arrived at in a much earlier geological era than has been observed in Europe; while the development of vertebrate life characteristic of the European Cretaceous period was, on the American Continent, continued into the Tertiary age. In short, in the West, we find an actual comingling in the same strata of characteristic types of these two formations. We have thus true transitional strata which render it impossible to say where the line may be drawn between the Tertiary and the Cretaceous formations, and a great gap which has hitherto perplexed geologists may be regarded as having now been bridged across.

I hope, on a future occasion, to discuss some of the questions that have arisen out of the wonderful palæontological discoveries that have been made during the last seven years, discoveries for the most part the result of Dr. Hayden's Survey.

The aid of photography, which was first called into

requisition in 1870, has proved most valuable; and the series of photographs which I exhibit this evening will present to your view the principal physical features and characteristic scenery of the west with vivid accuracy.

The photographs illustrating the antiquities of the Southwest introduce a subject which I hope to bring forward on another evening.

In conclusion, I congratulate the Society on the latest addition, made on the recommendation of its Council, to the roll of its Honorary Members. Dr. Hayden has been for twenty-five years an active explorer, and is the presiding genius of a Survey which stands unequalled for the zeal and proficiency of its staff, and the enlightened spirit of its organization. It is to be wished that the same liberal spirit was shewn by our own government in helping forward researches in natural science, and in placing the results of such surveys in the hands of all to whom they would be useful.

I bring my communication to a close by quoting Dr. Hayden's circular to correspondents, etc. :—

OFFICE U.S. GEOLOGICAL SURVEY OF THE
TERRITORIES.

WASHINGTON, D.C.

The writer is desirous of securing by exchange or purchase the publications of foreign countries on Geology, Palæontology, and Natural History generally, to aid in the formation of a library of reference for the use of the Survey of which he has charge.

He takes this method of asking those persons or societies that may receive the publications of the Survey, to reciprocate by sending to him such of their own publications as they may feel disposed, and he believes that he can assure them an ample return, either in books or specimens, or both.

The reports of surveys, with maps, charts, and sections, transactions of societies, or the publications of individuals engaged in scientific studies, are much desired as works of reference.

Parties who may look favorably upon the above proposition, can send all packages through the Smithsonian Institution, to the address of Dr. F. V. HADYEN, U.S. Geologist, Washington, D.C.

A careful record will be kept of the address of all the correspondents of the Survey. Societies, libraries, or persons failing to receive the publications of the Survey, will confer a favor by communicating the fact without delay.

THE SILVER QUESTION.

By J. C. REDISH.

I.

THE annual production of silver in the world prior to 1848 was estimated by the leading authorities at £8,720,000 per annum, and had varied slightly for many years, that production being found about adequate to supply the demand for coinage and manufacturing purposes; and silver remained pretty stationary at par with gold, on the basis generally recognised of gold being worth fifteen and a half times its own weight of silver. This, on the English plan of coining gold into sovereigns at the rate of £3 17s. 10½d. per oz., gave as the normal price of silver, estimated in pounds sterling, a rate of 60¾d. per oz.

For several years there was little change in the production of silver, though, in the meantime, the production of gold had largely increased, owing to the discoveries of that metal in California and Australia. The following table will show the production of the two metals from that period, and the changes in their respective proportions:—

Annual Average of five years.	Gold. Millions Sterling.	Silver. Millions Sterling.	Proportion of Silver to Gold.
1852-56	29.900	8.100	0.27 to 1
1857-61	24.600	8.200	0.33 " 1
1862-66	22.700	9.900	0.44 " 1
1867-71	23.600	10.600	0.41 " 1
1871-75	20.400	13.900	0.68 " 1

The production of silver for the year 1875 has been estimated at £16,000,000, or double what it was some twenty

years ago, and the proportion which its production bears to gold has varied greatly. Silver was produced, as compared with gold, in the proportion of 3 to 1 during the earlier part of the century; the proportion fell to .27 during the period of gold discoveries, and gradually rose to .68 to 1. It will be observed that, according to these computations, notwithstanding the late increase in the production of silver as compared with gold, its proportion to gold is still considerably below what it was in 1848, to say nothing of the period when the proportion was as 3 to 1, and the conclusion of the Select Committee seems justified, "that a review of the relations of the metals in times past shows that the fall in the price of silver is not due to any excessive production as compared with gold."

During the period of twenty-four years, from 1852 to 1875, the total production of gold is estimated at 572 millions, and that of silver at 242 millions, making together an aggregate of 814 millions sterling; the percentage of silver produced to each £100 of gold being for the year 1875 equal to 82.56, while for the whole period of the twenty-four years it has been 42.27.

The normal price of silver being 60½d., the actual price for bars fluctuated slightly, being sometimes above and sometimes below that rate, being influenced mainly by the demand for India, China, and the Straits, which varied from little more than half a million in 1867 to seven millions in 1874, with an average demand, during the past twelve years, of three millions per annum; for example, the yearly average of the price of bar silver, per ounce standard, ranged between 1862 and 1866 from 62d. to 61d.; in 1873, the yearly average was 59¼d.; in 1874, 58¾d.; in 1875, 56¾d.; while in 1876, the most unusual and violent fluctuations occurred, ranging from 56½d. in January to 52d. in May, and reaching 48¼d. in July, while

sales, we believe, were subsequently effected for a short period at rates even below that figure, say at 47d. The price, however, afterwards rallied, and a reaction set in, causing an advance to about 58d. in January last, from which time, however, it has declined considerably, and is now at about 54d., with great uncertainty as regards its future rate.

II.

The discovery of the silver mines in America, in the sixteenth century, caused silver to decline very seriously in its relation to gold, so much so that whilst, from 1560 to 1575, gold, according to the French Mint regulations, would purchase 11.17 to 11.44 times its own weight in silver, the value of the latter had so far declined, in 1640, that for its equivalent in gold 13.51 times its own weight had to be given; and, in 1665, it required 15.10 for the same purpose, according to the regulations of the same Mint. In our own day, on the other hand, the discoveries of gold in California and Australia caused a disturbance in their relative values in the other direction; and though the annual production of silver is double what it was a few years ago, there occurs a rise in the price corresponding in point of time with the increased production. These changes in the relative rates of production of the two metals were entirely unforeseen, and not the result of human arrangement, and we must therefore look in the future, as in the past, for a variation from time to time in the relative proportions of supply, and that, too in unknown and incalculable amounts, for "gold and silver, though the least variable in value of all commodities, are not invariable, and do not always vary simultaneously." (Mill).

Some few particulars regarding the past production of silver, and its proportionate value to gold, will be useful and instructive.

It is impossible to give, with confidence, any trustworthy statement of the production of silver in former times, but students of history have found sufficient references to the state of the coinage, and other points connected therewith, to enable them to calculate, to some extent, the relative values of the two metals at early and remote periods. The earliest relation subsisting between the metals seems to have been 1 : 13.93, which appears in ancient times, and for many centuries, to have suffered little variation ; this stability has been probably owing to the limited nature of commerce, and its control by the various governments. Herodotus, in his account of Indian tributes, B.C. 440, describes three hundred and sixty gold talents as being equal to four thousand six hundred and eighty silver talents, which would show a proportion of 1 to 13. In Greece, Egypt, and Italy, the value did not vary, as a rule, very far from the ancient rate, and in most cases such disturbances may be traced either to the sudden influx of gold from new quarters, or to the arbitrary action of governments for purposes of profit in coinage. During the reigns of the early Roman Emperors the rates varied from 11.97, under Augustus and Tiberius, to 14.40, according to the coinage of Constantine and his successors ; this latter rate, however, was probably only temporary, as during the reigns of most of these Emperors the silver coinage was debased, and hence the value of the precious metals, pure, was as 1 to 11, and even less.

During the Middle Ages, silver gradually rose in value for some centuries, until, about the year 1500, it was rated at 10.7 in Spain, by Isabella, being worth at the same time 10.5 in Germany. This was the average ratio in the commercial cities of Italy during the thirteenth century, and, being then exceptionally low, indicates a much greater supply of gold in that highly civilised region, at that time, than was available in the more warlike and less commercial parts of Europe ;

indeed, at that period the Italian cities of Milan, Florence, Lucca, Rome, and Naples were notably prosperous in trade and manufactures; and we may well believe that gold flowed in abundance to them, as to points where it could be safely and profitably invested. In the course of the fifteenth century there is no doubt the relative value of gold declined to about 10, and this is attributed to the scanty supply of silver, inadequate to meet the demands both of the silversmiths and of the traders to the East; the mines in the old world were nearly exhausted, and the treasures of the new world were, as yet, undiscovered.

This process did not continue for ever; disturbing causes soon occurred, and the relative value of silver gradually declined from 10.5, in 1500, to 15.10, in 1665, as already named; this result was caused by the large imports of silver into Europe from America, as well as the remarkable productiveness of the Bohemian and Saxon silver mines.

The annual supplies of the two metals is roughly estimated in the following table:—

		Gold.	Silver.
1550	..	£80,000	£520,000
1600	...	240,000	2,000,000
1650	...	460,000	3,000,000

The increased supply of gold came largely from the Guinea Coast and from Hungary, and the silver from Peru and Mexico; the production of silver being about seven times that of gold. Much of the silver found its way to the East Indies, enough, however, remaining to cause a fall in its relative value, an increased demand having set in for gold in consequence of the large war expenditure rendered necessary by the troubled state of Europe.

The following table shows the fluctuations in the ratio for upwards of a century and a half:—

Date.				Ratio.
1687-1700	14.97
1701-1720	15.21
1721-1740	15.08
1741-1790	14.74
1791-1800	15.42
1801-1810	15.61
1811-1820	15.51
1821-1830	15.80
1831-1840	15.67
1841-1850	15.89

Up to the beginning of this century the import of silver into Europe from America was continued and increased, being still chiefly required for the East, while from that quarter, in return, were received large quantities of gold; a most profitable transaction to the merchants in the trade, for while ten pounds of silver, bought in Europe and shipped to China or Japan, would exchange there for one pound of gold, this latter, on arrival in Europe, would exchange for fifteen pounds of silver; so no wonder the trade was well pushed, as it left a profit of no less than fifty per cent.

Between 1749 and 1761 there was a large supply of gold from Brazil, which caused a rise in the relative value of silver of four per cent.; from 1701 to 1748 the average ratio was 1 : 15.19; from 1751 to 1755 it was but 1 : 14.53, and the change would, no doubt, have gone on and become much greater but for the demand which then set in for gold, required by the United Kingdom for the purpose of coinage, and for the payment of heavy war subsidies to the continental nations during the struggle with Napoleon. Even whilst specie payments were suspended in England, the hoarding and the war subsidies kept up the price of gold, and a rise took place on the resumption of specie payments, the average for the year 1821 being 1 : 15.95; the demand for gold

being then greater than before, the value of silver in relation thereto fell, in obedience to the general law of supply and demand.

At the beginning of this century the average annual productions of gold and silver were estimated at £2,634,000 and £7,732,000 respectively, the values being in the proportions of 3 of silver to 1 of gold ; from then till 1829 the respective values were £1,600,000 and £3,640,000, being in the proportion of 2.3 of silver to 1 of gold ; and prior to the gold discoveries of 1848, the respective annual productions were £10,110,000 of gold to £8,720,000 of silver, showing that the production of silver was to gold as 0.86 to 1.

During the period under review, therefore, there had been a large absolute increase in the production of the metals considered jointly, but a much greater relative increase in the proportion of gold than silver. The natural tendency of this increased supply of one of the metals would have been to depress its relative value to the other ; in other words, to lower its purchasing power, or command over commodities in general, including the other metal, which is equivalent to a rise in the value of silver, for all expression of value is relative, and a rise of one implies a fall in the other ; this being simply the expression, in another form, of the same fact. In considering, however, the natural effect of an increased supply, political economists, for the sake of the pure abstract argument, assume, as a condition, that all other things—specially including demand—remain the same ; now this is what seldom or never happens in fact, and discredit is often unjustly thrown on political reasoners from a supposed discrepancy with actual facts. The test of a theory is its power to explain phenomena, and these require to be examined in their entirety before we can say whether there be any countervailing tendencies working in an opposite direction. Now, in this case, such tendencies are clearly known. There

was a concurrence of political and commercial causes, all intensifying the demand for gold, so that the actual effect was, that the augmented gold supplies, so far from influencing the market prejudicially, were found only sufficient to keep pace with the demand; and we must always remember that it is not the absolute supply of a commodity which determines its value, but the relation which that supply bears, at any given moment, to the effective demand, so that price is the product which ascertains and indicates the equation, at the time existing, between supply and demand; the result in this case showing, in the year 1846, an average ratio of 1 : 15.66.

III.

Before proceeding to examine the proportionate relative value of silver to gold from the year 1848, it will be necessary to inquire somewhat into the causes which were in operation, other than those of natural laws, having for their object the maintenance of perfect equilibrium between the two metals. France, in the year 1803, had adopted for herself the bi-metallic system, under which she coined both metals in the fixed proportion of $15\frac{1}{2}$ to 1, making either of them legal tender, at the option of the debtor, both in respect of public obligations and of private debts. The silver five-franc piece contains 347.25 grains of silver, and is of the full value which it represents, differing therein from the coins of lower denomination in that country, as well as from the English silver coinage, which is of nominal value only, being debased by the admixture of $12\frac{1}{2}$ per cent. of alloy, so that if melted there would result a loss to the operator to that extent, corresponding with the equivalent profit to the Mint on coinage. In France, and other countries adopting the double standard, the silver coins, other than the small token coins, are of full weight and purity, thus resembling the

English sovereign, which contains the full weight of gold at which it is rated, and is the equivalent of its own weight of bullion, there being thus no gain to the Mint on the coinage thereof, as there would be no loss to the holder on melting. In France any given sum in silver weighs the same as $15\frac{1}{2}$ times its value in gold. For example, ten francs in silver weigh the same as one hundred and fifty-five francs in gold; or, expressing the same fact in another form, any given sum in gold is worth the same as $15\frac{1}{2}$ times its own weight in silver. The French Mint, it should be mentioned, was in the habit of coining, either free or at a mere nominal charge, both gold and silver for private persons, on presentation, in the same way as the English Mint does in respect to gold, the full weight left at the Mint in the form of bullion being returned to the owner in the form of specie. The object of these regulations in both cases has been the same, namely, to establish free trade in regard to money, the owner of the precious metal regarded as money being enabled to procure the stamp of Government thereto, in attestation of its weight and fineness, thus enabling him to pass it into circulation and use for the purpose of legal tender in the ordinary way for the extinction of debt. Under this system there has always been a large amount of silver circulating in France, where, in fact, it formed the principal currency, and it has been estimated that since 1795 there has been coined upwards of £200,000,000 of silver coins of full value, of which there are probably now in circulation some £80,000,000. The magnitude and importance, therefore, of the silver question to France is seen to be enormous. By way of contrast, it may be stated that the amount of silver circulating in this country is estimated at about £15,000,000, the whole of it being of nominal value only, and used simply as a token coinage, not being available as a legal tender beyond the trifling amount of forty shillings;

the silver in France, as already named, being legal tender to an unlimited amount.

The States which have practically adopted this system of a double standard, using both gold and silver, are France, Belgium, Switzerland, Italy, Spain, Greece, Roumania, the United States, Columbia, Venezuela, Chili, Uruguay, and Paraguay. The States using a gold standard are England, Portugal, Turkey, Persia, Australia, the Cape, Canada, Brazil, and the Argentine Republic; and those using the single silver standard were Germany, Holland, Denmark, Sweden, Norway, Austria, Russia, Egypt, Mexico, West Indies, Central America, Bolivia, Ecuador, Peru, Japan, China, India, &c.

The totals of gold and silver in use as money, viz., coin in circulation, coin and bars held by banks and in the markets (exclusive of jewellery, plate, and quantities supposed to be hoarded), may be given as follows :—

In 1871. Under	Quantities in Millions Sterling.		
	Gold. Full value.	Silver. Full value.	Silver. As change.
Gold system - - - -	160	14	26.5
Gold and silver system -	340	121	31.5
Silver system - - - -	138	354	87.
Not accounted for - - -	68	—	—
Since to 1871 - - - -	49	16	—
	<u>£750</u>	<u>- £505</u>	<u>- £145</u>

It will thus be seen that there is in circulation in the world an aggregate value of silver, of full value, of upwards of five hundred millions sterling, and the importance of the silver question, not to France only, but to the whole world, will become apparent, and fully justify the deep interest with which this question is now being generally regarded.

To supply the demand for wear and tear, and for further requirements, the annual production of silver in 1848 has

been estimated at about £8,000,000, at which it remained nearly stationary for several years, amounting, on the average of five years ending 1871, to over £10,000,000; on the average of four years ending 1875, to about £14,000,000, and being estimated for 1876 at £16,000,000, thus showing an annual supply equal generally to about two and-a-half per cent. on the stock in the world at any given period; not more probably than was necessary for wastage and other purposes.

The various European States using the double standard found it convenient, in 1865, to come to a common agreement as to the quantities of silver used as fractional coins which each State should yearly issue, and they formed among themselves a combination for this purpose, known as "The Latin Monetary Union," the members being France, Belgium, Italy, and Switzerland, to which was added afterwards Greece. The following description of the Convention by which the Union was constituted is from official sources:—

"This Convention determines, among other points, the conditions of the emission of divisional coins which are struck at a rate inferior to that of the monetary standard, giving rise to several important conditions established by the Convention, the emission of the same being limited, and its acceptance not being obligatory beyond a certain fixed sum; the loss from wear being borne by the Government by whom it is emitted. It assures the legal circulation of the money of the one State in all the States of the Union; this being only imposed, however, on private individuals with regard to the national coinage, though it is admitted for the coins of all the States belonging to the Union. The amount to be emitted by each country is calculated at six francs per head of the population."

In consequence of the fall in the value of silver, a law was passed, in 1873, enabling the Belgian Government to

suspend or limit the coinage of five-franc pieces. This principle was subsequently adopted by the States of the Latin Union; and at the meetings of their respective delegates, which have taken place annually at Paris since 1874, the limitation of the silver coinage has been still further restricted. The action taken by all the members of the Union, in suspending the free coinage of silver, has naturally exercised a very important influence on the market. Up to that time it was open to anybody to go to the French, or any other Mint of the Union, with silver or gold, as the case might be, and get it coined; the consequence was, that the moment either metal became depreciated, the holders took it to those Mints and had it coined; but, in the year 1874, that process was arrested, because those Governments limited the amount of silver which they would coin; and if it had not been for that change of policy, the silver which flooded the London market, and lowered the price, would have flowed into the Mints of those countries. This was a departure from the original theory, and constituted a cardinal alteration in their policy, the theory of the double standard being that anyone should be at liberty to bring metal to the Mint and get it coined to any amount; but that was then altered. In its original conception, the policy of the Latin Union has been supposed to have been partly a political movement on the part of the French Empire to gain an influence in those countries, and partly the natural wish of countries so intimately connected to have the same coinage, and they adopted the French coinage of that time as being that of the predominant power; it was not formed at all with reference to the question as between silver and gold, they simply adopted the French currency of the time.

In the meantime, France has taken up an "expectant" attitude; the Government, last year, procured the assent of the Legislature to a provisional enactment, to the effect that

“The manufacture of pieces of five-francs in silver may be limited or suspended by the Government; the present law having force only till 31st January, 1878.” What her ultimate policy may be it is impossible to say; on the one hand, she might begin to coin silver in unlimited amounts, and that would take silver off the market; this course is, however, scarcely probable. On the other hand, the Government may go further, and demonetise the silver in France; that has been proposed, and such action would throw an additional amount of silver on the market. Whichever way they may decide, their policy will have a considerable effect, either in promoting the depreciation of silver, or in retarding its depreciation; and that policy, with regard to the future, is, in the opinion even of the most competent authorities, alike obscure and uncertain. One thing in regard to it is both certain and clear, namely, that the decision, when taken, will constitute a force of the first magnitude.

IV.

The bi-metallic system, adopted by France and the Latin Union, has found so much favour in the eyes of some economists, principally French, that great efforts are now being made to induce this country, along with the other leading nations of the world, to enter into an arrangement whereby either metal would be used and received as money, and thus avert the actual and future decline in silver. The leading advocate of these views is the eminent French economist, M. Cernuschi, who says:—

“France being a market at the fixed rate of $15\frac{1}{2}$ —a market always open to all nations—the $15\frac{1}{2}$ was enforced on every nation. Neither in England nor in America, neither at Constantinople nor at Calcutta, were people willing to give more than $15\frac{1}{2}$ of silver for 1 of gold, nor more than 1 of gold for $15\frac{1}{2}$ of silver. The legal rate of

France was the regulating rate of the whole world. It was in this manner that the relative value of gold and silver always remained stationary in the world—so stationary indeed that in English statistics the quantity of silver could always be expressed in gold sovereigns. A gold sovereign always represented a fixed weight of silver. Now, however, the old bi-metallic constitution is no longer at work in Europe. France now coins gold alone. Europe is making a mono-metallic experiment. Here is the sole cause of the depreciation of silver. Nowhere does the law any longer link the value of silver with the value of gold, hence the reason why the value of silver will no longer have any fixity.

“Silver was more than simple merchandise, it was a legal tender. All the new silver was entitled by law to be worth, and was worth, as much as the silver formerly coined; it will be no use waiting years and years, silver will never recover the value which it possessed when it was a legal tender in Europe. Bound up with gold by the French $15\frac{1}{2}$, the value of silver was as stable as that of gold; it will henceforth be as unstable as that of copper. Inaction will only aggravate the evil, and the only effective action in this matter is that of legislation. Bad laws have been passed; let there be good ones. *Lex abstulit, lex dabit.*”

“It is not possible to re-construct the past just as it was: Germany cannot re-sell gold to become again silver mono-metallic, and France cannot alone at her own risk and peril re-commence coining silver. Bi-metallism can only be rehabilitated by the co-operation of all States, India included. The mischievous mono-metallism cannot be abandoned without establishing a bi-metallism still more beneficial than the French bi-metallism—universal bi-metallism.

“Would it not be advisable to agree that the ratio $15\frac{1}{2}$ might be modified after a certain period? No; either the ratio is irrevocable, or bi-metallism cannot stand. . . .

No depreciation can befall one metal relatively to the other, and consequently the relation between the weight of the gold coin and that of the silver coin never needs alteration. Knowing that he could prescribe for perpetuity, the legislator of 1803 took good care not to say that the $15\frac{1}{2}$ should be merely provisional and subject to modification; the $15\frac{1}{2}$ was never modified, and during three-quarters of a century it *governed* the relative value of gold and silver in the entire world. It will appertain to the International Congress to re-establish it, to declare it universal, and thus to give it absolute stability. This will be a great benefit for all nations."

In a table already given there will be found the actual ratio which existed during the first half of the century in Europe, by which it will be seen that the actual ratio never was, on an average of years, the normal rate of $15\frac{1}{2}$; on the contrary, from 1820 till 1850, it would appear that silver was relatively cheaper than gold, so that instead of one ounce, or one pound, weight of gold being worth exactly $15\frac{1}{2}$ ounces or pounds, as the case might be, of silver, it was worth, on the average, for each of the decades ending 1850, 15.80, then 15.67, then 15.83, thus showing a profit sufficient to induce the holder to send his silver to the Mint, and keep his gold for the outside world; this, therefore, he did, and the currency of France became substantially silver, as indeed the French people desired, for in their language one word, *Argent*, expresses at once the idea of silver and that of money. Under the free action of this system there was coined in France, between the years 1803 and 1848, gold of the value of £47,450,000, and silver of the value of £155,680,000, thus showing a preponderance in favour of the latter metal of rather more than three to one, when, as shown above, silver was, during the whole of the period, relatively the cheaper metal.

In 1848 occurred the discoveries of gold in California,

followed immediately afterwards by further discoveries of this metal in Australia, and then the previous relations between the metals were disturbed. The following table will show the production of the precious metals from that date, the averages being given for periods of five years :—

ESTIMATED PRODUCTION OF GOLD AND SILVER.

GOLD.		
1848	Stock - - - -	£400,000,000
1848	Annual production -	£10,110,000
1852-56	Five years' average -	29,900,000
1857-61	" " -	24,600,000
1862-66	" " -	22,700,000
1867-71	" " -	23,600,000
1872-75	Four years' " -	20,400,000
SILVER.		
1848	Annual production -	£8,720,000
1852-56	Five years' average -	8,100,000
1857-61	" " -	8,200,000
1862-66	" " -	9,900,000
1867-71	" " -	10,600,000
1872-75	Four years' " -	13,900,000
1876	One year's " -	16,000,000

By the above it will be seen that whilst the annual production of gold had averaged ten millions, with a corresponding average of eight millions for silver, the yield of gold sprang up to thirty millions on an average of the years 1852-56, remaining at nearly the same high level, say at twenty-five millions, for the next five years, and at twenty-three millions for the subsequent five; whilst silver slightly declined in productiveness, though rising during the years 1862-66 to an average yield of nearly ten millions.

Let us now examine what effect, if any, this change, in the relative proportions produced, had upon the proportions in which the metals exchanged for one another in the world.

The following table shows the ratio which silver bore to gold from 1851 onwards, being the first year when the gold had come forward in sufficient abundance to afford a fair test. This table is derived from the Report prepared for the American Government, by the United States Commissioner of Mining Statistics, and the relative values are calculated from the London quotations, which gives the price of a given weight of standard silver in shillings and pence sterling. There being in this country no charge for the coinage of gold, the price referred to varies exactly as the market values of the metals, and the ratio, therefore, can be calculated with perfect accuracy. London being the acknowledged centre of the commercial world, this ratio determines the relative value of the metals among civilised nations. The table shows annual averages only, not extremes :—

RELATIVE VALUES OF GOLD AND SILVER.

Date.	Ratio	Average.	Date.	Ratio.	Average.
1851	- 15.46	-	1863	- 15.38	
1852	- 15.57	-	1864	- 15.40	
1853	- 15.93	-	1865	- 15.33	15.388
1854	- 15.93	-	1866	- 15.44	
1855	- 15.36	- 15.410	1867	- 15.57	
1856	- 15.93	-	1868	- 15.60	
1857	- 15.27	-	1869	- 15.60	
1858	- 15.86	-	1870	- 15.60	15.562
1859	- 15.21	-	1871	- 15.59	
1860	- 15.90	- 15.294	1872	- 15.63	
1861	- 15.47		1873	- 15.90	
1862	- 15.96		1874	- 16.15	15.817

V.

The fact has now been made clear that, during the present century, there have been two important changes in the ratio which silver has borne to gold. Up to the period of the gold discoveries silver was below the fixed par value; then, from 1851 till 1866, it was of more value in the open market than the fixed ratio; while from the latter date it has gone on gradually declining. It has, therefore, passed through three successive stages. It will be interesting to consider the effects which these changes have had in France, where the ratio remained fixed by operation of law. We are told that, under the operation of that law, "no depreciation can befall one metal relatively to the other;" "there is no competition possible between the producer of gold, and the producer of silver," and no inducement to make payments in one metal rather than another, "their paying power being identical."

Free coinage of either metal being allowed in France, it is natural to suppose that, in choosing which metal to send in to the Mint, the holder would give the preference to that which he could procure in the form of bullion on cheaper terms. Thus, during the first half of this century, when one ounce of gold would purchase, on an average, somewhere about fifteen-and-three-quarter ounces of silver, it was found more profitable to send silver into the Mint, as there fifteen-and-a-half ounces would be coined free into as much currency as the one ounce of gold. From 1825 to 1848, inclusive, the French coinage was only 268,000,000 francs in gold, against 2,380,000,000 francs in silver, equal to £10,720,000 in gold, against £95,200,000 in silver. The result was that the whole actual currency of France was silver, the relatively cheaper metal having been used for the purpose.

The gold discoveries then took place; the change already

described in the ratio of silver occurred, this metal becoming relatively dearer than gold. Did the French people then carry their silver to the Mint? No, they knew their own private interests better. A very slight change in the value was sufficient to affect their policy. Though they had been accustomed to send in formerly large quantities of silver, they soon discontinued doing so; the coinage of five-franc pieces, which in 1851 amounted to francs fifty-seven millions, and in 1852 to francs seventy millions, fell to francs nineteen millions in 1853, and to fifty-three thousands only in 1854. The coinage of full weight five-franc pieces averaged for the five years ending 1855, thirty-four millions per annum, falling, during the next five years, to nine millions per annum, while, for the succeeding five years, it amounted to less than one-fifth of a million per annum; this decline exactly corresponding with the enhanced price of silver, as shown in the previous table of ratios.

During the whole of this period gold, being relatively cheaper than silver, was coined in preference, being sent into the Mint under the French law which permitted this option; and the result was, that, from 1851 to 1867, inclusive, the coinage of gold amounted to francs 5,806,000,000 = £232,240,000, while that of silver only amounted to francs 383,000,000 = £15,320,000, or, on an average of years, £12,900,000 of gold, against £876,000 of silver. These figures are instructive in the highest degree; they show the change which was taking place, and which was due entirely, not to the policy of the Government, but to the action of the public, simply as individuals; each one consulting only his own interest, and being guided by that motive alone.

It has been shown already that the silver coinage in France diminished from thirty-four millions per annum to nine millions, then almost ceased, during the years 1851-66, and reference to the following table will show what became of

SILVER IN FRANCE.

	Balances.			Coinage.	
	Import.	Export.	Average.	5-franc pieces.	Average per annum.
1851	78		fcs.	57,496,000	
1852		3	"	69,951,000	
1853		117	"	19,458,000	
1854		164	"	53,000	
1855		197 — 80	"	24,305,000	34,250,000
1856		284	"	45,777,000	
1857		360	"	467,000	
1858		15	"	133,000	
1859		171	"	16,000	
1860		157 — 197	"	—	9,279,000
1861		62	"	110,000	
1862		86	"	105,000	
1863		68	"	108,000	
1864		42	"	160,000	
1865	72	— 37	"	485,000	193,000
1866	45		"	189,000	
1867	189		"	54,051,000	
1868	109		"	93,620,000	
1869	112		"	58,264,000	
1870	35	+ 98	"	53,648,000	51,954,000
1871	15		"	4,710,000	
1872	102		"	389,000	
1873	181		"	154,649,000	
1874	360		"	59,996,000	
1875	194	+ 170	"	75,000,000	58,949,000
1876	148				

the silver in the meantime. While France, up to 1851, had been in the habit of importing that metal, she then ceased doing so, and for the next fourteen years regularly exported the silver to such an extent, that for the five years ending 1855 the exports averaged eighty millions of francs per annum, with the still higher average of one hundred and ninety-seven millions for the next five years, thus showing that the movements of the metals were vitally affected by the change in the choice of the metal preferred for the coinage.

France had now fallen away from her old love for silver. *Argent* still meant money, but did not necessarily refer to that metal, and gold had now become practically the circulating medium. A large portion of the new gold was required for this purpose, and thus there sprang up an "increased demand," corresponding in time with the "increased production;" this prevented any great decline in the value of gold, either in regard to its purchasing power, or command over commodities in general, or in relation to silver. But whilst there thus occurred] an increased demand for gold, of which otherwise there would have been a superfluous quantity, there occurred likewise, necessarily, a diminished demand for silver for the purpose of coinage, and the operation of these joint causes was to maintain both metals more steady in their relative values than they would otherwise have been. It is this *compensatory*, or *equilibratory action*, which helps to steady] the ratio, and which operates advantageously in the first instance, by affording an outlet for the excess of supply, at any moment, of that metal which happens to be more abundant. It must be observed, however, that this process could not continue for an indefinite period. Under the operation of what is known as Gresham's Law, viz., that *Bad Money drives out Good Money*—or, as we should prefer to express it, *Inferior Money drives out Superior Money*—the tendency is for the

currency of a country, under such a system, to change from the one metal to the other, according as there are changes in the supply and demand, elsewhere, or for other purposes ; it thus loses that fixity of value which is the chief desideratum in a currency, and cannot, in fact, be fairly described as a currency of two metals, but is an "alternative" currency, consisting sometimes of one metal and sometimes of the other. No country can maintain two standards of value in actual use at the same time ; and in every country which has adopted the double standard, that metal has been used, to the exclusion of the other, which was over-valued as coin as compared with the value of the bullion contained in the coin when tested by its market price in other countries. Consequently, in every country having the double standard, the metal which is over-valued as coin has been used to the exclusion of the other. This is a system which is not conformable to the highest theory, and has been abandoned in practice ; because the laws of Nature are stronger than the laws of France, and the selfish instincts of mankind make them ready to grasp a profit, even though of the very smallest percentage.

FRANCE.

Years.	Ratio.	Total Gold production. Av. per An.	Imports and Exports of Silver. Balances.	Coinage 5-franc pieces. Av. per An.
1831-35			+ 98	160
1836-40	15.670		+ 94	74
1841-45		10.110	+ 97	72
1846-50	15.830		+ 127	108
1851-55	15.410	29.900	— 80	34
1856-60	15.294	24.600	— 197	9
1861-65	15.388	22.700	— 37	.2
1866-70	15.562	23.600	+ 98	52
1871-74	15.817	20.400	+ 170	59

VI.

Although unable to concur with the French economists in thinking an "alternative" currency a good arrangement, we are firmly persuaded that silver is well suited for use as money, and that it would be an advantage to the world if it were more largely used in that capacity, in the more civilised nations, where it might circulate alongside of gold, and enter largely into the currency. It possesses some advantages of its own, even from its lower value, being thus better suited for transactions of small amount where the sum is low, and also because the pieces, although of small value, can in such case be made of a reasonable size, and are, therefore, more suitable for handling by all classes of the community. It seems to us, therefore, matter for regret that it should have become so generally demonetised, and that an almost exclusive preference should be everywhere shown for gold. If one metal is to be used to the entire exclusion of the other, then we think that the advantage is in favour of gold, but it might be quite possible to use them both *jointly*, and this, for some reasons, would be preferable to using either of them *singly*. From the earliest times they have both been used as money, and the natural instincts of mankind, in this as in so many more instances, prompted them to right action, without investigating any theory on the subject at all. The fact that they are, in the long run, produced in nearly equal quantities in value is itself a significant circumstance; the present value of all the gold in the world is estimated at £750,000,000, and that of the silver at £650,000,000, so it would appear that there are about equal masses of value available for coinage, if required. Although the annual production of either metal varies considerably, from time to time, it seldom happens that there is an increased or diminished supply of both at once, and thus it is that the

variation in the production of both metals is much less than the variation in the production of either metal, taken singly. This will be apparent from the following table:—

ANNUAL PRODUCTION.				
		Gold.	Silver.	Total.
1852	...	£36,550,000	£8,120,000	£44,670,000
1864	...	22,600,000	10,840,000	32,940,000
1871	..	21,400,000	12,210,000	33,610,000
1875	...	19,500,000	16,100,000	35,600,000

This will show that while during a very few years the annual supply of gold fell to one-half, that of silver in the same time having exactly doubled, the variation in the supply of the joint metals was only as 44 to 35, and this, be it observed, during the time when there have been perhaps the greatest and most sudden fluctuations ever known in the productions of each of the two metals. Now, this would seem to point out the desirability, at all events, of adopting the Joint Metal as the Standard of Value; it possesses, in a higher degree than either metal singly, that prime quality—stability of value. There have been changes in our day in the value, or purchasing power, of gold, the standard of value in this and some other countries, and now there is a still greater change in the value, or purchasing power, of silver, which has been adopted as the standard of value in some other countries. Those nations which have adopted the French bi-metallic system, which we have called the “alternative” system, have not escaped; they have suffered most of the evils which befall a nation choosing the cheaper metal for their standard, for they have given their subjects the option of changing the standard from time to time; in fact, they have never had a standard of *both* the metals, as they vainly desired, but a standard sometimes consisting of the one metal and sometimes of the other. Their intentions were good, but good intentions are not sufficient to avert failure.

If a nation wishes to have a composite legal tender, consisting of both metals, it must make the use of both compulsory, not optional. If the option remains with the debtor, as in France, he will choose the cheaper metal; if the option had been with the creditor he would have chosen the dearer metal, and all the phenomena we have described would have been reversed. It is difficult to know why, in this respect, the debtor should have had the advantage, which would have been grossly unfair, were it not that, in most other cases, the laws have been made so as greatly to favour the creditor. The debtor, however, had one additional pleasure, or drawback, as he might choose to consider it; the law never intended that he should have this advantage; it was an incident which resulted without knowledge or intention, and the result has been denied after having been accomplished. To maintain perfect fairness in the fulfilment of contracts, especially those which, like the terms of leases or annuities, spread over a lengthened period, or, like those of life insurance, are only to be fulfilled in a distant future, the Standard of Value should be as firm and invariable as human ingenuity can devise. The "Composite Metal," consisting of equal values of gold and silver, seems to attain this object better than any single substance yet known. The proportions of 1 to 15½ seem best for practical purposes, and would be more readily accepted than any other ratio, though we must bear in mind that such ratio is neither scientifically nor practically perfect; it is simply a plan, not a principle.

Let us apply this form of True Bi-metallism to the case of France, or any country similarly circumstanced; let it be decreed that, in the discharge of all obligations amounting to some fixed sum, say one thousand francs, or upwards, the debtor shall be entitled to pay, and the creditor shall have the right to demand, one-half the amount in gold and the other half in silver. This is real bi-metallism; this is using

the two metals *jointly*; this would be making law and fact correspond with theory, which is not now done under the present system. So long as the fixed ratio was preserved, the operation of the law would be imperceptible, for so long as the two metals remained of equal value there would be no advantage in offering the cheaper or demanding the dearer metal; the present system does not effect this. Either metal, as at present, might remain legal tender for small amounts, say under one thousand francs.

There need be no objection on the score of inconvenience, for though using the two metals jointly as the Standard of Value, it would seldom or never be necessary to use both in making payments. It would suffice that they were lodged in the Bank, and that notes were redeemable in the two metals jointly, unless otherwise desired. Or, better still, the necessary quantum of the metals could be lodged in the Mint, and certificates, or notes, given against them for the exact amount deposited, and no more; these being legal tender, which might be required in fulfilment of all obligations, and so would preserve the stability of the standard of value, while the Bank would be free to issue its own notes, and, though legally bound to meet them in Mint certificates, as named above, would seldom find any objection on the part of its note-holders to take either gold or silver as offered. So long, in fact, as the two metals were at par there would be no inducement, unless for private convenience, to demand such certificates, which would only be met in the joint metals; and neither would there be any inducement to reject either metal which the Bank might offer. But the instant there was a change in the ratio, such as has already twice happened under the present French system, there would arise a preference for notes over the depreciated specie, whichever it might happen to be, and a corresponding disinclination on the part of debtors to pay away the dearer

metal; so that the cheaper metal would require to match itself with the dearer one, and being thus united in the Mint, or Issue Department, would be available for its legitimate use, as legal tender, to the extent to which it is fairly entitled, say one-half, and no more. Then would come into play that *compensatory action* of which we have previously spoken; it would be impossible that the cheaper metal should be used exclusively, and it would likewise be impossible that the dearer metal should be driven from circulation; they would both be equally necessary, and the increased demand for one would be met with a corresponding demand for the other.

These suggestions are thrown out with a view to mitigate the heavy fall in silver, consequent mainly on the demonetisation of that metal in Germany. The heavy strain thus thrown on France she has been unable to bear under her present bi-metallic law, which permits the use of *either* metal, of course leading to the use of the cheaper one, or that for which the demand is less intense; she has been compelled to suspend the free coinage of silver, and is anxious about the future. She is, therefore, in a favourable condition now to avail herself of the true application of bi-metallism, which would bring to her great relief, and would, in her case, be no departure from the fundamental principles of her system, but rather a strict adherence to them. We do not know what proportion of silver the Bank of France now holds, but last year she held fifty-five millions of gold, along with twenty millions of silver, estimated in sterling, and probably the proportions are still about the same. If her notes, then, were made redeemable, not in one or other of the metals, but in both jointly, and if a corresponding obligation were imposed in regard to all other contracts in France, not otherwise specially provided for, free coinage of silver might be resumed with impunity. In the instance given above, the Bank of France would tell off twenty millions

of its gold to match the twenty millions of silver ; it would then find itself with a gold surplus of thirty-five millions ; but in order to comply with the demands which might come upon it under the new rule, it would find it expedient to part with half that surplus of gold, gradually exchanging it for silver, until, as the result, there would be equal values of gold and silver in its vaults. This would release the dearer, and tend to appreciate the cheaper metal, thus restoring that harmony which the old system endeavoured, vainly, to accomplish. Any redundant silver coinage in France would find its way to the Bank, to be there mated with gold, before creditors could be compelled to accept it for larger payments than one thousand francs, and every five-franc piece in existence would retain its full exchange value, on the single condition that it shared its utility with a corresponding value in gold, and was content with equality, without seeking supremacy.

This application of bi-metallism has the advantage that it is available for any one country, without the assent or concurrence of any other nation being necessary, and is, therefore, possible of attainment, whereas the proposal of "universal" bi-metallism might have to wait long for its accomplishment ; and this plan would, if applied in any one instance, effectually prevent that drain of the dearer metal, and that inundation of the cheaper one, which is unavoidable under the present system. France would no longer suffer from the financial policy of her neighbour, Germany. A similar application of the same principle could be made in Germany, which has now, in fact, a circulation consisting of both metals. No new coinage would be necessary in the case of either countries, and there would be no clashing of interests. It would enable, nay compel, the Banks of countries adopting the Composite Standard to keep one-half of their reserves in silver ; and though that metal is now depressed, there may again come a change, and the inclination may be the other way.

To show, to some extent, the demand this would create and maintain for silver, the following table, giving the reserves of the leading European Banks, may be considered:—

			Coin and Bullion.
Bank of England	£27,355,000
Bank of France	87,072,000
Austrian National Bank	18,660,000
Belgium	"	...	4,618,000
Netherlands	"	...	12,617,000
			<hr/>
			£145,322,000

These reserves are mostly in gold; the proportion of silver in the Bank of France last year has been shown; at the same time one-half of the reserve in the Austrian Bank was in silver; but the English reserve consists entirely of gold, and of the whole, we should not estimate that more than thirty millions consist of silver. Under the Composite system these five Banks would be found holding about seventy millions in silver, along with seventy millions in gold, and there would, therefore, always be an ample store of either metal to meet a sudden demand for extraordinary purposes.

America has not yet finally decided on the system on which, as we hope, her future financial policy may be firmly based; but she has always aimed at bi-metallism, though she has never accomplished it, from the inherent defects of the only form of it which has been tried; she is therefore free, and all the more so from her paper currency being now depreciated, and can adopt, as her permanent standard of value, that which appears to her the best. The silver trade dollar is worth in gold ninety-five to ninety-six cents, while the Government and Bank-note paper dollar is worth about ninety-seven cents in gold. The silver being the least valuable of the three several classes of currency—gold, paper, and silver—it will soon, to the extent of its function, drive the

two former out of circulation. The silver being the cheapest, will be first paid out by every holder; the gold and the paper, each being worth a little more, will be held in reserve. Thus, the silver coin, if encouraged, will soon become the chief circulating medium. With the Composite Standard she might still use silver as the circulating medium to a very large extent, and such currency is probably better adapted to the habits and requirements of her people than one of gold; she, too, could adopt such a system whether other nations did so or not, as in every case such other nations would be powerless to drain her of one metal to the exclusion of the other. A drain of metal generally is, of course, a danger to which every nation, having any, is subject; but her standard of value would be firm, and little variable.

So far nothing has been said of England; here we have a single gold standard, nevertheless this country might, with great propriety, enter the proposed International Conference on the Silver Question, for the purpose of considering whether it is wise to provide, by treaties and concurrent legislation, for the use of both silver and gold by all the commercial nations upon a fixed relative value, there considering all the proposals and suggestions which might be made. In the event of other leading nations generally giving the preference to the Composite Standard of Value, she might possibly find it her interest to do so likewise. There need be no fear in regard to existing contracts at the time of change, if ever made, for reason and justice would demand that existing contracts should be fulfilled in gold, at maturity, if required by the creditor, public or private.

This Silver Question has many sides; but we shall be glad if these suggestions help to elucidate some of the difficulties, and promote a solution which is important to the interests of so many persons and of every nation.

VII.

America is probably more free than any other country in regard to the coinage system, and any change, therefore, could be more readily adopted by her than by either France or England, which have already a large amount of hard coinage in existence. The first necessity of a commercial people is that their Standard of Value should be of itself accepted by other commercial nations, for one of the chief uses of the precious metals as a Standard of Value is for the purpose of liquidating balances with other countries. As long as silver is merely an article of commerce in Great Britain, where the bills of America due to other countries are finally adjusted, the use of silver only as a standard in America will not produce the results which ought to follow from a resumption of specie payments. London is now the clearing-house of the world, and as balances there must be settled in gold, other commercial nations must make that metal the sole Standard of Value, unless England can be induced to accede to a general arrangement securing the adoption of the bi-metallic standard. The old American dollar contained $412\frac{1}{2}$ grains of silver, nine-tenths fine, but these coins have been nearly all driven from circulation. In deciding on the weight of the future silver dollar, there would be great advantage in assimilating it to the existing French silver five-franc piece; this coin contains 347.25 grains of fine silver, and it would be well to adopt that weight. England might also adopt the same weight for a new English Dollar, or four-shilling piece. It would then only be necessary for America to adopt the English sovereign as her gold five-dollar piece, and her course would be easy. Her Standard of Value, on the basis of which all contracts would be made, would consist of one-half gold and one-half silver dollars, of the same weight and value as the French écu, and the English dollar. She might

in such case coin chiefly, in the first instance, silver dollars only, which would be required mainly for circulation and general use in minor transactions. It is only for small amounts that coin ever passes, all larger ones being arranged, in one way or another, by the use of paper. The needful gold, for deposit in the Mint or Banks, could readily consist, in the first instance, of bullion or English sovereigns. The value of the dollar would remain fixed at four shillings, through being thus linked with gold, even if there occurred a further decline in silver. The Circulating Medium need not, necessarily, be identical with the Standard of Value, as may be seen in the instance of a paper currency, which will be maintained at par value "so long as it is convertible on demand into specie;" so a silver currency will maintain its full par value so long as it is available for direct conversion into the Standard of Value itself. In this way America could utilise her present large supplies of silver without finding herself with a currency, or standard, of less value than that of other nations; she would likewise be able to replenish her currency from England, and sovereigns could readily be circulated there. It would be necessary to enact, in America, that debtors should have the option of paying in either gold or silver to the extent of one hundred dollars only, the creditor for larger sums being entitled to demand notes only, which would be redeemable in Composite Standard money, consisting one-half of gold and one-half of silver.

The adoption of the "Composite Metal," as the basis of the Standard of Value, would much facilitate the resumption of specie payments in the United States. There the country is divided in opinion as to the shape which resumption should assume. One party holds that advantage should be taken of the current low value of silver to redeem the debt in that metal, which they consider themselves entitled to do, as under the contract with the Bond-holder he cannot claim, as

of right, gold, or, in some cases, even silver, but only "coin," or "lawful money of the United States." A very large and influential party favours this view, which would open up a market for one of the native products of the country, and would also enable the Government to return to specie payments on somewhat easier terms than if gold were required. Another party, however, maintains that gold alone should be adopted as the standard, and that America should thus be brought into harmony with the leading nations of Europe. Conflicting interests, as well as opinions, are, of course, involved, and, as a result, the Commission appointed specially to consider this matter has recommended the adoption of an unrestricted coinage of both metals, although it is unable to fix the standards at which the relative values of the two metals shall be fixed. Strong attempts are now being made to repeal this proposal, and the final decision remains uncertain. A double standard of value attempted to be set up in metals whose relative market values are liable to constant fluctuations, is a proposal which can hardly be carried into execution without disaster, and would be a dead letter, at the best, if it were. The practical effect of resumption on this basis will be to secure the preference of the cheaper metal, which at present is silver, and thus America will find herself with a standard and currency consisting exclusively of that metal.

Now let us consider the effect which the adoption of the Composite Standard would have upon the American Note and Bond-holder. At present, if paid off at par, in gold, at New York, his \$500 bond would be worth £103 2s. in London, whilst if paid off, in silver, it would be worth £95 16s. It may be admitted to be doubtful to which of these results he is entitled, and the option seems to remain with the indebted Government, which, either directly or through the operation of the so-called double system, may

ultimately pay him off in silver worth only the lower sum. Suppose, however, that, through the adoption of the Composite Standard, his claim was met one-half in gold and one-half in silver, then he would receive the mean between these two amounts, or the equivalent of £99 9s. in liquidation of his bond for five hundred dollars. This may be regarded as the mean average value of his claim. By bringing the American dollar into harmony with the English system, as named above, the creditor would receive in discharge of his claim for five hundred dollars, the equivalent of one hundred pounds in England, which would be one-half per cent. more advantageous to him than the present value thereof, fairly computed in both gold and silver, and the difference between paper and coin being thus so small, the Government would be relieved from a large portion of the difficulty they will otherwise have to face when resuming specie payments. There would be scarcely any contraction of the currency required, and thus the fall in prices which generally attends resumption would be avoided. Both Note and Bond-holders would be better off than if repaid in silver, and the permanent stability of the American Standard would be secured.

In England there is no four-shilling piece, or pure silver coin ; we are therefore tied by no precedent, and no arrangements. In coining pure silver for the first time, therefore, we should naturally adopt the same weight as that chosen for the leading French and American silver coin, as the silver coinages of the three countries could then be interchanged with advantage. Such pure silver coins might be made legal tender here to the extent of one hundred, which would be equal to £20, when used by themselves, and, in conjunction with gold, they could be legal tender to the extent of one-half. The Bank of England could hold one-half of its reserve in silver, and our Standard of Value would be identical with

that of America. There, however, no doubt, the ordinary circulating medium would be silver, while here it would be gold, and either nation could borrow direct from the currency of the other, when required.

Let the weight of the English sovereign be adopted as the fixed point in gold, and the weight of the French five-franc piece be adopted as the fixed point in silver, and let all other computations and arrangements be subordinated thereto.

It must be mentioned that, if the proportions of $15\frac{1}{2}$ to 1 were adhered to, the English four-shilling piece would require to contain 350.625 grains of silver, in lieu of 347.25 recommended above; but then it would correspond with no other system and no other coin. England and America are neither of them bound to the proportion of $15\frac{1}{2}$, and the adoption of the above weight would place the proportions at 15.350. The $15\frac{1}{2}$ has been displaced by force of circumstances, and the nations are free to adopt the proportion they consider best. In fact, the Netherlands Government, in 1875, passed a law fixing the ratio of gold to silver at 15.625. We are firmly convinced that no power on earth will ever persuade the English people to change the weight of the English sovereign to make it correspond with twenty-five francs, but the same result can be accomplished in another way, and the fixity of the sovereign is more important than the $15\frac{1}{2}$; in fact, the one exists and the other does not. England might be induced to coin silver, and accept the Composite Standard, if France and America did the same, but the interests bound up with the sovereign are too great to be given up entirely. There would be little or no change in England, and America has to make a change somehow. Prejudices, as well as interests, have to be consulted, and if the American dollar corresponded with one-fifth of a pound sterling, their fates would be linked with security.

The English silver dollar, or four-shilling piece, would readily find a useful place in the circulation here; it would be a coin specially suited to the wants and requirements of the working classes and of retail trade, and could be very largely used in many transactions; it would soon become the unit of account in retail transactions, and would answer the purpose better than the higher-valued sovereign. There is certainly a want of some coin, between the shilling and the pound, which should be of higher value than the florin, a coin which has never succeeded in getting into the favour with which the old crown piece was regarded. The dollar should be coined at the Mint free, and the full weight of silver delivered as bullion should be returned in the form of coin, as is now done in the case of gold. There could be no depreciation as compared with gold, for if redundant they would be available for export, for which they would have many advantages, and would thus reduce the strain upon gold in cases where metal had to be exported for the settlement of exchanges. Being identical in size, weight, and purity with the American dollar and the French five-franc pieces, the currencies of the three countries would be interchangeable to the great advantage of all concerned. The Standard of Value being also identical in the three countries, Exchange operations would be much facilitated, and the merchant would save the differences of which he is now deprived by the intervention of the banker or bullion dealer. The metallic basis of the country would be widened by the increased use of silver, and thus the way be paved for the complete disuse of bankers' promissory notes in favour of more approved and more modern forms of credit.

The only coinage of the three countries which would not be in harmony would be the French Napoleons, but they do not now circulate in England, nor do they correspond with any point in the English or American systems. France

would have to adopt the new proportion of 15.350 in lieu of the $15\frac{1}{2}$, but, as she is now unable herself to retain the latter, she must make some concession to get England and America to adopt the joint use of silver with gold, and through this action on their part she would gain more than the loss involved to her in the slight change in the rating of silver. As named already, the $15\frac{1}{2}$ has been overthrown, and it is only by common agreement that a ratio can be adopted. France will find it impossible to get all other nations to adopt her system of the double standard on the basis of the $15\frac{1}{2}$; and, in fact, it is not France that desires it, but only a minority of her financiers. It might probably be better if silver could be rated lower than the 15.350 named above, but then France would lose the advantage of her silver coinage touching any point in the English or American systems, and unless all nations would consent to start *de novo*, there must be some inconvenience suffered somewhere; that would be slight, however, under the suggestions given above.

France would gain the general adoption of the bi-metallic system, thus securing for her in the future what she has attempted in the past, namely, the joint use of both metals, now endangered—her principle being good, though her plan was bad—and she would also witness the triumph of the five-franc piece becoming the great and universal Silver Unit of the world, rivalling the position held in respect to gold by the English sovereign; so that she would obtain that share in influencing the commercial ideas and usages of the world to which her greatness, both in thought and action, entitles her.

FREE PUBLIC LIBRARY, MUSEUM, AND GALLERY OF ART,

OF THE BOROUGH OF

LIVERPOOL.

MUSEUM REPORT, No. 1.

MOLLUSCA OF THE ARGO EXPEDITION TO THE
WEST INDIES, 1876.

BY THE

REV. HENRY H. HIGGINS, M.A.

PRELIMINARY NOTE ON THE VOYAGE
OF THE "ARGO."

TOWARDS the close of 1875, a voyage to the West Indies was planned by Reginald Cholmondeley, Esq., of Conover Hall, Salop, in pursuance of his desire to enrich his already extensive and well-stocked aviary with specimens from the Antilles and Tropical America, and to have an opportunity of observing the habits of animals, and especially of birds, in their native haunts. For this purpose he chartered the fine new screw steam-ship "Argo," of 750 tons register, built by Alfred Holt, Esq., of Liverpool, which thus became duly qualified to leave the port as the Royal Mersey Steam Yacht "Argo."

Unwilling that so fine an opportunity for collecting in all departments of Natural History should be lost, Mr. Cholmondeley expressed to the Committee of the Liverpool Free Public Museum his readiness to accommodate in the "Argo" a member of their Institution, to be nominated by the Committee; generously offering to place the whole of the invertebrate specimens collected at the disposal of the Liverpool Museum.

The Committee conferred the honour of their choice on the writer of this Report, who, ultimately, by an extension of Mr. Cholmondeley's kind offer, went on board accompanied by two assistants selected from the Museum staff, Mr. John Chard and James Woods. The "Argo" left Liverpool on the morning of January 16th, 1876, and returned to the same port on the 27th of the following May.

The places visited were Madeira, Antigua, Barbuda, St. Kitt's, Guadeloupe, Dominica, Martinique, St. Vincent, Grenada, Trinidad, Pedernal, La Guayra, Caracas, Puerto Cabello, Tucacas, Santa Marta, Savonilla, Cartagena, Jamaica, Cuba, Vera Cruz, the Bahama Islands, and Philadelphia.

LIVERPOOL MUSEUM

REPORT, No. 1.

MOLLUSCA COLLECTED DURING A VOYAGE TO THE WEST INDIES IN THE ROYAL MERSEY STEAM YACHT "ARGO."

The shells in the following list represent the conchological results of dredging and shore collecting during the Argo Expedition. Every possible facility and assistance was kindly granted by Mr. Cholmondeley, but circumstances over which he had no control prevented all dredging from the Argo, thereby entirely excluding deep sea dredging, for which due preparations had been made. Even in harbour, the boats and crew of the yacht were frequently not available for marine collecting, and in some localities a few hours only could be given to the work. The names in the following list are those adopted by Messrs. H. and A. Adams, in their work on the "Genera of Recent Mollusca." The work of identification has been done by Mr. F. P. Marrat, conjointly with myself. The figures in the Plate were drawn by Mr. John Chard, of the Museum staff.

Species marked † have not, so far as the writer is aware, been previously recorded from the West Indies.

Comparatively very few species are recorded from beached-specimens only. Nearly all of them were dredged or picked off the rocks in a living state.

MADEIRA.

UNIVALVES.

Purpura.

Thalassa deltoidea. Lam.

Stramonita hæmastoma. L.

Trochocochlea turbinata. Born.

Patella penicillata. Reeve, var-

ANTIGUA.

Antigua is not a very favourable locality for shell collecting. Falmouth harbour has a fine sandy beach; but nearly all the shells obtained there were attached to corals and sponges, dislodged by a diver using a crow-bar and ropes. In English Harbour some small shells were dredged; but the most productive locality was found to be the walls and wooden piles of the government coaling station, on which, at low water, a variety of shells were collected without difficulty.

UNIVALVES.

- | | |
|--------------------------------------|---|
| Purpura patula. <i>L.</i> | Rhizoehilus. |
| † Stramonita fasciata. <i>Reeve.</i> | Coralliophila abbreviatus. <i>Kien.</i> |
| Thalassa deltoidea. <i>Lam.</i> | Cantharus. |
| Tritonium. | Tritonidea Loroisi. <i>Petit.</i> |
| † Simpulium vestitum. <i>Hinds.</i> | Turbo. |
| † Gutturium tuberosum. <i>Lam.</i> | Livona pica. <i>L.</i> |
| Columbella mercatoria. <i>L.</i> | Nassa. |
| Mitra. | Hima ambigua. ¹ <i>Pult.</i> |
| Nebularia striatula. <i>Lam.</i> | Bulla nebulosa. <i>Gould.</i> |
| Leucozonia nassa. <i>Gmel.</i> | Cypræa. |
| Murex. <i>Sp ?</i> | Trivia pediculus. <i>L.</i> |
| Trochus. | Nerita. |
| Lithopoma tuber. <i>Gray.</i> | Pila peloronta. <i>L.</i> |
| Cerithium caudatum. <i>Sow.</i> | tessellata. <i>Gmel.</i> |
| Modulus lenticularis. <i>Chem.</i> | striata. <i>Chem.</i> |
| Tectarius muricatus. <i>L.</i> | Fissurella. |
| Emarginula. | Cremides clathratula. <i>Reeve.</i> |
| Subemarginula depressa. <i>Bl.</i> | rugosa. <i>Sow.</i> |
| Crypta. | nodosa. <i>Born.</i> |
| Crepidatella aculeata. <i>Chem.</i> | Lucapina Dysoni. <i>Reeve.</i> |
| Calyptra equestris. <i>L.</i> | Vermetus lumbricalis. <i>L.</i> |
| Cuma diadema. <i>Lam.</i> | Lucerna (Helix). |
| | Dentellaria formosa. ² <i>Ferus.</i> |

BIVALVES.

- | | |
|------------------------------------|---------------------------------|
| Cardium. | Radula. |
| Trachycardium muricatum. <i>L.</i> | Ctenoides scabra. <i>Born.</i> |
| Lithophaga. | Venus. <i>Sp ?</i> |
| lithoglypha <i>Meusch.</i> | Mytilus ovalis. <i>Lam.</i> |
| nasuta. <i>Phil.</i> | Corbula nuciformis. <i>Sow.</i> |
| Arca umbonata. <i>Lam.</i> | Pinna D'Orbigny. <i>Hanley.</i> |

¹ *Nassa ambigua* is a common West Indian shell, formerly supposed to be British.

² *Helix formosa* is said to be found only in Antigua and Barbuda; the beautiful specimen in the collection was presented by Mrs. Mends, of St. John's, Antigua.



1

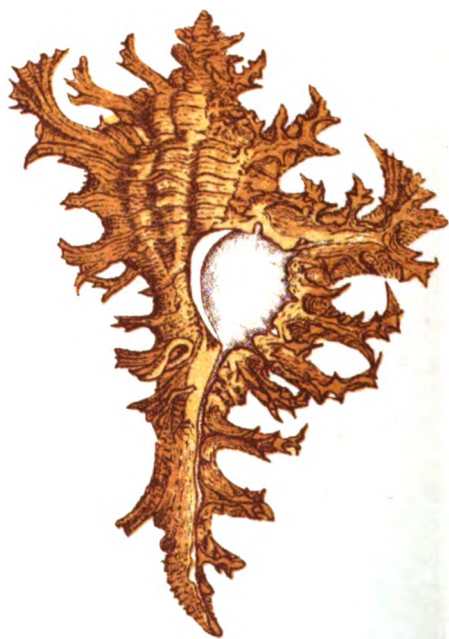

2

Barbatia fusca. Brug.	Pecten exasperatus. Sow.
Acar gradata. Brod.	Pseudamussium argenteus. Reeve.
Lucina.	Rocellaria. Sp.?
Myrtæa scabra. Lam.	Isognomon serratula. Reeve.
Chama macrophylla. Chem.	

BARBUDA.

The coast of Barbuda is formed by a long and low line of drifting sands, yielding scarcely any shells except after a storm. At half a mile from the beach the depth is 15-20 fathoms, with a hard sandy bottom, from which the dredge returns with scarcely more than a handful of contents. We dredged for about two hours with small results; but a day's dredging in a little deeper water about a mile from the shore might, I think, be very successful.

UNIVALVES.

+ <i>Sconsia Barbudensis</i> . ¹ Higgins and	<i>Trivia pediculus</i> . L.
<i>Spirula</i> . Sp.?	[Marrat. <i>Cerithium litteratum</i> . Born.
<i>Nerita</i> .	<i>Cerithidea costata</i> . Lam.
<i>Pila peloronta</i> : L.	ambigua. C. B. Ad.
tessellata. Gmel.	<i>Strombus</i> . Sp.† young.
<i>Fissurella</i> .	<i>Murex</i> . Sp.†
<i>Lucapina Listeri</i> . D'Orb.	<i>Cassidea testiculus</i> . L.
<i>Bulla amygdalus</i> . L.	† <i>Vasum globulus</i> . ² Reeve.

¹ *Sconsia Barbudensis*. Higgins and Marrat, Liv. Mus. Report. No. 1, plate 1, fig. 1. Natural size. S. testa ovata, pallide fulva, castaneo longitudinaliter flammulata, transversim indistincte striata, versus labrum et varicem subdecussata; spira conica; anfractibus sex; labio cum callo tenui tecto; labro extus subincrassato, intus lirato.

Animal unknown. The shell is distinguished by the character of the genus, of which two species have been previously described. Differs from *S. striata*, Lam., in the plications of the inner lip, which are confined to the anterior portion; in the transverse striations, which are even and not crenulated; and in the colour pattern, which is formed by undulating streaks of reddish-tawny colour on a paler ground. I am indebted to Mr. Edgar Smith, of the British Museum, for the knowledge of *Sconsia Grayi* (A. Adams, P.Z.S., 1854), from which shell it differs in the conical spire and flamed colour-pattern, and in the distant striations. Dredged in good condition, but without the animal, in fifteen fathoms water, off the Island of Barbuda.

² *Vasum globulus*. This shell was given to me by the Rev. J. Cowley, Incumbent of Barbuda. It differs much from the specimen figured by Reeve, but agrees well with Kiener's figure.

- | | | |
|------------------------------------|--|------------------------------------|
| Conus. | | Purpura patula. <i>Linn.</i> |
| Chelyconus columba. <i>Hwass.</i> | | Columbella mercatoria. <i>L.</i> |
| Natica. | | Nitidella nitida. <i>Lam.</i> |
| Mamma mamilla. <i>L.</i> | | Dolium perdid. <i>L.</i> |
| Olivella pulchella. <i>Reeve.</i> | | Nassa. |
| Guildingii. <i>Reeve.</i> | | Hima ambigua. <i>Pult.</i> |
| Dactylus. | | †annellifera. <i>Reeve.</i> |
| Strephona reticularis. <i>Lam.</i> | | Rissoa fragilis. <i>Mich.</i> |
| Cypræa exanthema. <i>L.</i> | | Drillia vexillum. <i>Reeve?</i> |
| cinerea. <i>Gmel.</i> | | Modulus lenticularis. <i>Chem.</i> |

BIVALVES.

- | | |
|------------------------------|-----------------------------|
| Ervilia nitens. <i>Mont.</i> | Lucina. |
| Venus. <i>Sp.?</i> | Codakia tigerina. <i>L.</i> |
| | Myrtea scabra. <i>Lam.</i> |

ST. KITT'S.

Saw a cabinet of shells in the possession of Dr. Branch, who gave me a number of fine specimens of *Amphibulina patula*, a Succinea-like shell, supposed to be found in this island only.

FRESH-WATER SHELLS.

- | | |
|----------------------------------|--------------------------------|
| Amphibulina patula. <i>Brug.</i> | Physa Cubensis. <i>Pfeiff.</i> |
|----------------------------------|--------------------------------|

LAND SHELLS.

- | | |
|---|-------------------------------|
| Orthalicus. | Subulina octona. <i>Chem.</i> |
| Leptomerus Hondurasanus. <i>Pfeiff.</i> | Oleacea. |
| Helicina. | Electra. <i>Sp.?</i> |
| Pachystoma Dysoni. <i>Pfeiff.</i> | |

DOMINICA.

UNIVALVES.

- | | |
|---|-------------------------------------|
| Purpura patula. <i>L.</i> | Columbella mercatoria. <i>L.</i> |
| †Stramonita fasciata. <i>Reeve.</i> | Nassa. |
| †Cuma diadema. <i>Lam.</i> | Hima ambigua. <i>Pult.</i> |
| Livona pica. <i>L.</i> | Bulla amygdalus. <i>Lister.</i> |
| Tectura striata. <i>Quoy. and Gaim.</i> | Dactylus. |
| Cumingii. <i>Reeve.</i> | Strephona olivaceus. <i>Meusch.</i> |
| Nerita. | Planaxis semisulcata. <i>Sow.</i> |
| Pila striata. <i>Martyn.</i> | Lophyrus squamosus. <i>L.</i> |
| tessellata. <i>Gmel.</i> | assimilis. <i>Reeve.</i> |
| peloronta. <i>L.</i> | marmoratus. <i>Chem.</i> |
| Neritella. | |
| Vitta meleagris. <i>Lam.</i> | |

BIVALVES.

- | | |
|--------------------------------|---------------------|
| Mytilus. | Axinea. <i>Sp.?</i> |
| Aulacomya exustus. <i>Lam.</i> | |

LAND SHELLS.

Bulimulus.	Lucerna.
† <i>Petræus rugatus</i> . <i>Reeve</i> .	<i>Dentellaria Josephinæ</i> . <i>Ferus</i> .
<i>Guadaloupensis</i> . <i>Brug.</i>	<i>nigrescens</i> . <i>Wood</i> .
<i>Helicina</i> . <i>Sp.?</i>	<i>pachygastra</i> . <i>Gray</i> .

ST. VINCENT.

The harbour of Kingstown affords excellent shore collecting at low water; but, whilst wading amongst the rocks, it is well to be on the look out for the occasional influx of a wave much larger than ordinary.

UNIVALVES.

Murex.	Columbella.
<i>Phyllonotus oculatus</i> . <i>Reeve</i> .	<i>Nitidella nitida</i> . <i>Lam</i> .
<i>Purpura patula</i> . <i>L</i> .	<i>Mitrella cribraria</i> . <i>Lam</i> .
<i>Thalessa deltoidea</i> . <i>Lam</i> .	<i>Latirus</i> . <i>Sp.?</i>
† <i>Stramonita fasciata</i> . <i>Reeve</i> .	<i>Tectura candeana</i> . <i>D'Orb</i> .
<i>Pisania pusio</i> . <i>L</i> .	<i>var.</i>
<i>Tritonium tritonis</i> . <i>L</i> .	<i>Bulla amygdalus</i> . <i>L</i> .
† <i>Guttarium cynocephalum</i> . <i>Lam</i> .	<i>Emarginula</i> .
<i>Planaxis semisulcata</i> . <i>Sow</i> .	<i>Subemarginula depressa</i> . <i>Blain</i> .
<i>lineata</i> . <i>Da Costa</i> .	<i>Lucapina cancellata</i> . <i>Soland</i> .
<i>Cypræa cinerea</i> . <i>Gmel</i> .	<i>Tectarius dilatatus</i> . <i>D'Orb</i> .
<i>Trivia pediculus</i> . <i>L</i> .	<i>muricatus</i> . <i>L</i> .
<i>Conus</i> .	<i>Littorina</i> .
<i>Stephanoconus mus</i> . <i>Hwass</i> .	<i>Melaraphe zic-zac</i> . <i>Chem</i> .
<i>Nerita</i> .	<i>carinifera</i> . <i>D'Orb</i> .
<i>Pila peloronta</i> . <i>L</i> .	<i>Omphalius excavatus</i> . <i>Lam</i> .
<i>albipunctata</i> . <i>Reeve</i> .	<i>Lophyrus squamosus</i> . <i>L</i> .

BIVALVES.

<i>Isognomon serrata</i> . <i>Reeve</i> .	<i>Barbatia</i> .
	<i>Acar divaricata</i> . <i>Sow</i> .

GRENADA.

Just before leaving the Island, I made a hasty inspection of a very interesting collection of shells, formed by Mr. Rowley, a resident in Georgetown. The whole of his specimens had been collected by himself, in that most beautiful of all harbours, the Carinage.

Murex.

Chicoreus imbricatus. *Higgins and Marrat*.

Murex (Chicoreus) imbricatus. *Higgins and Marrat*. Liv. Mus. eport, No. 1, plate 1, fig. 2. Natural size. M. testa subelongato-

fusiformi, transversim granoso-lirata, inter varices fortiter bi vel tri-tuberculata, trifasciam varicosa, varicibus conspicue confertim frondosis, laciniato-foliosis, ad apicem spinosis, incurvis laminato-squammatibus; columella lævi; aurantio lutescente, liris rufofuscis; apice rubescente.

Animal unknown. Shell differing from *M. palma-roseæ*, Lam., by its rounder aperture and much more delicate growth. The fronds on the varices are finely divided, and are imbricated or squamulose to the recurved tip, which is prolonged into a pale spine. Dredged in the Carriage, Island of Grenada.

I saw, in Grenada, a series of this Murex, in the possession of Mr. Rowley, of Georgetown. The shells varied from an inch in length to the size of the specimen figured. None of them resembled any other Murex I had ever seen.

TRINIDAD.

The great and almost land-locked harbour, the Gulf of Paria, resembles the mouth of a large river. Its shore, for many miles, is, in fact, part of the delta of the Orinoco, and its shallow waters are every where more or less turbid, whilst the bottom is formed of a soft mud, obviously deposited by the river. Dredging is quite useless except in the neighbourhood of the Bocas, or Dragon's Mouth, where a few small shells may be found. The land and fresh-water shells have been carefully collected by Mr. Guppy, a resident in Port of Spain.

UNIVALVES.

Nassa.

Phrontis antillarum. Phil.

FRESH-WATER SHELLS.

Pomus urceus. Mull.

Marisa cornu-arietis. L.

Neritella.

Vitta Mertoniana. Recluz.

LAND SHELLS.

Bulimus.

Plecocheilus glaber. Gmel.

distortus. Brug.

LA GUAYRA.

UNIVALVES.

Antalis inversa. Desh.

Acus hastata. Gmel.

Euryta consentini. Phil.

† *Ziziphinus Leanus*. C.B. Ad.

Nassa.

Hima ambigua. Pull.

<i>Persicula Kieneriana.</i> <i>Petit.</i>	<i>Columbella.</i>
<i>Olivella parvula.</i> <i>Mart.</i>	<i>Nitidella laevigata</i> <i>L.</i>
<i>gracilis.</i> <i>Brod. and Sow.</i>	<i>Eutropia.</i>
<i>Dactylidia mutica.</i> <i>Say.</i>	<i>Tricolia.</i> <i>Sp.?</i>
	Operculum of <i>Senectus.</i>

BIVALVES.

Tivela. *Sp.?*

The shells from La Guayra were dredged by James Woods, during my absence on land. *Persicula (Marginella) Kieneriana*, a beautiful little shell of very unusual occurrence in collections, was obtained at about half a mile N.N.W. of the anchorage. It has not been recorded from any other locality.

VENEZUELA.

LAND SHELLS.

Bulimus oblongus. *Müll.*

CARACAS.

Presented by DR. ROJAS.

<i>Bulimus.</i>	<i>Helicina.</i>
<i>Plecocheilus euryomphalus.</i> <i>Reeve.</i>	<i>Pachystoma agglutinans.</i> <i>Sow.</i>
<i>Orthalicus.</i>	
<i>Mesembrinus spectabilis.</i> <i>Reeve.</i>	

PUERTO CABELLO.

UNIVALVES.

<i>Purpura patula.</i> <i>L.</i>	<i>Drillia.</i>
<i>Thalessa deltoidea.</i> <i>Lam.</i>	<i>Crassispira.</i> <i>Sp.?</i>
† <i>Stramonita fasciata.</i> <i>Reeve.</i>	<i>Tritonium tritonis.</i> <i>L.</i>
<i>Murex recurvirostris.</i> <i>Brod.</i>	<i>Cassidulus melongena.</i> <i>L.</i>
<i>Chicoreus elongatus.</i> <i>Lam.</i>	<i>Littorina.</i>
<i>Cerithium caudatum.</i> <i>Sow.</i>	<i>Melaraphe undulata.</i> <i>Lam.</i>
<i>Sp.?</i>	

BIVALVES.

<i>Arca occidentalis.</i> <i>Phil.</i>	<i>Radula.</i>
<i>Americana.</i> <i>Lam.</i>	<i>Ctenoides scabra.</i> <i>Born</i>

TUCACAS.

Dredging at this station was very laborious, whether in the harbour or in the lagoons, which extend for many miles inland. The dredge usually came up filled with a mixture of sand and mud, requiring, at

each haul, a long time and much work before it could be sufficiently washed to render the smaller shells visible. Nevertheless, the proceeds, on the whole, were interesting, though perhaps less so in shells than in various other marine productions. The Argo remained for five days at Tucacas.

UNIVALVES.

- Cassidulus melongena. *L.*
 Purpura.
 Thalassa deltoides. *Lam.*
 Stramonita floridiana. *Conrad.*
 fasciata. *Reeve.*
 Terebra.
 Myurella armillata. *Hinds.*
 Nerita.
 Pila striata. *Martyn.*
 peloronta. *L.*
 tessellata. *Gmel.*
 Neritella.
 Vitta Mertoniana. *Recluz.*
 Bulla amygdalus. *List.*
 Strombus gigas. *L. with Operc.*
 Young.
 Murex recurvirostris. *Brod.*
 Tritonium tritonis. *L.*
 † Gutturium cynocephalum. *Lam.*
 Distorsio cancellina. *Desh.*
 Modulus lenticularis. *Chem.*
 Livona pica. *L.*
 Turritella.
 Haustator variegata. *L.*
 Drillia pallida. *Sow.*
 affinis. *Gray*
 Bolma rugosa. *L. var.*
- Omphalius excavatus. *Lam.*
 Natica Broderipiana. *Muhl.*
 Persicula interruptolineata. *Muhl.*
 Marginella.
 Cryptospira prunum. *Gmel.*
 Hondurasensis. *Reeve.*
 Nassa.
 Phrontis zonalis. *Brug.*
 Semicassis inflata. *Shaw.*
 Dactylus.
 Strephona olivaceus. *Meusch.*
 Porphyria scripta. *Lam.*
 Leptoconus proteus. *Brug.*
 Chelyconus pusio. *Lam.*
 Cypræa isabella. *L.*
 Bursa.
 † Lampas affinis. *Reeve.*
 Dentalium pseudo-sexagonum. *Desh.*
 Cerithium litteratum. *Born.*
 Sp. ?
 Littorina.
 Melaraphe zic-zac. *Chem.*
 columellaris. *D'Orb.*
 Tectarius muricatus. *L.*
 pyramidalis. *Quoy.*
 Marisa luteostoma. *Sicain.*
 Lophyrus squamosus. *L.*

BIVALVES.

- Callista dione. *L.*
 exspinata. *Reeve.*
 Chione cancellata. *L.*
 Timoclea granulata. *Gmel.*
 Tivela mactroides. *Born.*
 young.
 Lævicardium serratum. *L.*
 vitellinum. *Reeve.*
 Cardium.
 Trachycardium muricatum. *L.*
 Siliquaria gibba. *Speng.*
 Lucina.
 Codakia tigerina. *L.*
 pecten. *Lam.*
 Myrtea muricata. *Speng.*
- † Periploma inæqualvis. *Schum.*
 Leda ventricosa. *Hinds.*
 Elenensis. *Sow.*
 Adrana tellinoides. *Wood.*
 Thracia plicata. *Desh.*
 Tellina.
 Tellinella pulchella. *Lam.*
 Angulus similis. *Sow.*
 Strigilla piciformis. *L.*
 Sp. ?
 Vola aspersa. *Sow.*
 Standella.
 Merope Senegalensis. *Phil.*
 Spisula corbuloides. *Desh.*

- Donax denticulatus. L.*
Scapharca ovata. Reeve.
 compacta. Reeve.
 † *nux. Sow.*
- Corbula crassa. Hinds.*
 Cubaniana. D'Orb.
Anatina. Sp.?

SANTA MARTA.

UNIVALVES.

- Bulla nebulosa. Gould.*
Bolma rugosa. L. var.
Natica canrena. L.
Turritella.
 Haustator variegata. L.
Latirus infundibulum. Gmel.
Purpura patula. L.
 Thalessa deltoidea. Lam.
 Sp.?
 Stramonita fasciata. Reeve.
Nerita.
 Pila striata. Martyn.
 tessellata. var.
Neritella.
 Vitta Mertoneana. Risso.
Murex recurvirostris. Brod.
 Chicoreus megacerus. Sow.
Mamma. Sp.?
Cerithium litteratum. Born.
Littorina.
 Melaraphe carinifera. D'Orb.
- Marginella.*
 Cryptospira marginata. Born.
Emarginula.
 Subemarginula octoradiata. Gmel.
Uvanilla brevispina. Lam.
Architectonica granulata. Lam.
Persicula interrupto-lineata. Muhlf.
Scala.
 Clathrus clathrus. L.
Leptoconus.
 Chelyconus pusio. Brug.
Strombus tubercularis. Lam.
 with operculum.
 young.
Mazza scolymus. Gmel.
 with operculum.
- Dactylus.*
 † *Strephona oblonga. Marrat.*
 olivaceus. Meusch.
 † *Tectura aspera. Lam.*

BIVALVES.

- Perna tulipa. Lam.*
Cardium.
 Trachycardium subelongatum. Sow.
 Isocardia isocardia. L.
Hemicardia.
 Fragum media. L.
- Donax denticulatus. L.*
 † *Heterodonax ovulinus. Desh.*
Anomalocardia antiquata. L.
Chione.
 Circomphalus paphia. L.
Venus crenulata. Chem.
Pinna pernula. Chem.

The Argo remained a few hours only at Santa Marta. I saw *Mazza scolymus* taken by a man who waded in the bay where the water was up to his chest, and felt for the shells with his feet. He was hunting for the *Mazza*, which he knew to be a less common shell. At length I saw him duck for his prize, which he brought on shore with great expectations. The beautiful Olive *Strephona oblonga*, Marrat, was brought for sale in large numbers. The animal is of a mottled colour, not unlike the shell, but with more of purple.

POINT SAVANILLA.

UNIVALVES.

- | | | |
|---|--|---------------------------------------|
| Purpura. | | Columbella mercatoria. <i>L.</i> |
| Stramonita fasciata. <i>Reeve, var.</i> | | Mitrella cribraria. <i>Lam.</i> |
| Thalassa deltoidea. <i>Lam.</i> | | Cerithium Eriense. <i>Val.</i> |
| † Latirus angulifera. <i>Lam.</i> | | Fissurella. |
| Tritonium. | | Cremides Barbadosensis. <i>Gmel.</i> |
| Simpulum. <i>Sp.?</i> | | Conus |
| Guttarium tuberosum. <i>Lam.</i> | | Stephanoconus mus. <i>Hwass.</i> |
| Livona pica. <i>L.</i> | | Siphonaria palpebram. <i>Reeve.</i> |
| Nerita. | | Bulinus? Guadaloupensis. <i>Brug.</i> |
| Pila peloronta. <i>L.</i> | | |
| tessellata. <i>Gmel.</i> | | |

BIVALVES.

- | | |
|------------------------------------|--------------------------------|
| Isognomon serratula. <i>Reeve.</i> | Cardium. |
| | Isocardia isocardia. <i>L.</i> |

CARTAGENA.

Here, as elsewhere, *Strombus gigas*, *L.*, abounded; but the specimens here brought on board had on the columella a wondrous golden sheen, which, however, soon disappeared. The animals were very strong, and, after lying awhile on deck, would protrude themselves as far as possible from the shell, which they would fling over with great vigour. Their eyes were bright and well formed, but had a most sinister aspect.

HAVANA.

UNIVALVES.

- | | |
|--|--------------------------------------|
| Murex recurvirostris. <i>Brod.</i> | Neritella. |
| Tritonium. | Vitta pupa. <i>Lam.</i> |
| Guttarium tuberosum. <i>Lam.</i> | meleagris. <i>Lam.</i> |
| Cantharus. | Conus. |
| Tritonidea proteus. <i>Reeve.</i> | Stephanoconus mus. <i>Hwass.</i> |
| † Loroisi. <i>Petit.</i> | Pentadactylus. |
| Lithopoma tuber. <i>L. var., spined.</i> | Sistrumanaxares. <i>Duclos.</i> |
| Nerita. | <i>Sp.?</i> |
| Pila peloronta. <i>L.</i> | Columbella mercatoria. <i>L.</i> |
| striata. <i>Chem.</i> | Mitrella cribraria. <i>Lam.</i> |
| Littorina. | Nassa. |
| Melaraphe guttata. <i>Phil.</i> | Phrontis zonalis. <i>Brug.</i> |
| <i>Sp.?</i> | Fissurella. |
| zic-zac. <i>Chem.</i> | Cremides Barbadosensis. <i>Gmel.</i> |
| Tectarius dilatata. <i>D'Orb.</i> | Tectura leucopleura. <i>Gmel.</i> |
| Bulla amygdalus. <i>List.</i> | Crypta. |
| | Crepidatella aculeata. <i>Chem.</i> |

BIVALVES.

Venus cancellata. <i>L.</i>	† Anomalocardia nux. <i>Sow ?</i>
Chione.	Mytilus.
Circumphalus paphia. <i>L.</i>	Aulacomya exustus. <i>Lam.</i>
Asaphus deflata. <i>L. var.</i>	Chama macrophylla. <i>Chem.</i>
Isognomon serratum. <i>Reeve.</i>	Lucina.
Tellina.	Myrtea muricata. <i>Chem.</i>
Tellinella lineata. <i>Turton.</i>	
Angulus similis. <i>Sow.</i>	

Presented by the HAVANA MUSEUM.

Eurycratera.	Cochlea imperator. <i>Montf.</i>
Polymita picta	Lucerna.
Helicina.	Serpentulus sagemon. <i>Beck.</i>
Emoda titanica. <i>Poey.</i>	

VERA CRUZ.

UNIVALVES.

Semicassis inflatus. <i>Shaw.</i>	Nerita.
Conus.	Pila striata. <i>Martyn.</i>
Stephanoconus mus. <i>Hwass.</i>	Nassa.
Tritonium.	Hima ambigua. <i>M.</i>
Simpulum pileare. <i>L.</i>	Littorina.
Latirus.	Melaraphe columellaris. <i>D'Orb.</i>
Mitra.	Cerithium. <i>Sp. ?</i>
Scabricola granulosa. <i>Brug.</i>	Janthina globosa. <i>Swain.</i>
Purpura.	exigua. <i>Lam.</i>
Thalessa deltoidea. <i>Lam.</i>	Fissurella Hondurasensis. <i>Reeve.</i>
<i>Sp. ?</i>	Lucapina cancellata. <i>Soland.</i>
† Stramonita fasciata. <i>Reeve.</i>	Ampullaria Linnæi. <i>Phil.</i>
Mamma. <i>Sp. ?</i>	Planorbis. <i>Sp. ?</i>
Ruma mamillaris. <i>Born.</i>	

BIVALVES.

Mytilus.	Perna tulipa <i>Lam</i>
Aulacomya hamatus. <i>Say.</i>	

NASSAU.

This being our last station for marine collecting, on our arrival I lost no time in engaging a boat for the period of our visit. Dredging and shore collecting were prosecuted vigorously for four days, in all suitable directions. We took with us one or two divers to dive for coral, and to bring large stones from below low-water mark, to be examined for limpets, chitons, &c. A general account of our proceedings and collecting grounds will be found in "Notes of the Argo Expedition," read before the Liverpool Naturalists' Field Club, 1876-7.

UNIVALVES.

- Columbella mercatoria*. *L.*
Nitidella nitida. *Lam.*
Fissurella Hondurasensis. *Reeve.*
Cremides Barbadosensis. *Gmel.*
Lucapina cancellata. *Soland.*
viridula. *Lam.*
Clypidella fascicularis. *Lam.*
Tectura cimelita. *Reeve.*
leucopleura. *Gmel.*
 † *Siphonaria cochleariformis*. *Reeve.*
Obeliscus terebellum. *Mull.*
Terebra.
Myurella larvæformis. *Hinds.*
Acus hastata. *Gmel.*
Melampus coffeus. *L.*
Tralia pusilla. *Gmel.*
Littorina.
Melaraphe columellaris. *D'Orb.*
carinifera. *Mke.*
var.
Tectarius muricatus. *L.*
dilatatus. *D'Orb.*
 † *Antonii*. *Phil.*
Cerithium eburneum. *Brug.*
gracilliforme. *Sow.*
litteratum. *Born.*
variabile. *C. B. Ad.*
Dolium perdix. *L.*
Vermetus lumbricalis. *L.*
Cassis Madagascariensis. *Lam.*
flammea. *L.*
tuberosa. *L.*
Cassidea testiculus. *L.*
Tritonium variegatum. *L.*
Gutturium antillarum. *D'Orb.*
Epidromus. *Sp.?*
Persicula guttata. *Link.*
Purpura patula. *L.*
Thalessa deltoidea. *Lam.*
var.
 † *Stramonita fasciata*. *Reeve.*
- Drillia*.
 † *Crassispira fucata*. *Reeve.*
Conus.
Stephanoconus mus. *Hwass.*
nebulosus. *Soland.*
verrucosus. *Hwass.*
Leptoconus flavescens. *Gray*
Livona pica. *L.*
Cyphoma gibbosa.¹ *L.*
Nassa.
 † *Hima obtusata*. *A. Ad.*
Bulla amygdalus. *List.*
 † *Cuma diadema*. *Lam.*
Strombus accipitrinus. *Mart.*
Turritella. *Sp.?*
Scala.
Clathrus clathrus. *L.*
Gibbula dentata. *L.*
Astraliu longispinum. *Lam.*
Omphaliu scalaris. *Anton.*
Senectus Menkeanus. *Gmel.*
Fasciolaria tulipa. *L.*
Rissoina Bryerii. *Mtg.*
Morum oniscus. *L.*
Natica marochiensis. *Recluz.*
Cypræa exanthema. *L.*
cinerea. *Gmel.*
Luponia spurca. *L.*
Trivia pediculus. *L.*
var. dark red.
Dactylus.
Strephona olivaceus. *Meusch.*
Olivella pellucida. *Reeve.*
Nerita.
Pila peloronta. *L.*
striata. *Martyn.*
tessellata. *var.*
Volva subrostrata.² *Sow.*

¹ The animal of *Cyphoma gibbosa* does not seem to have been known to Messrs. H. and A. Adams. The shell, when the animal is feeding, is entirely covered by the mantle margin, which is of a bright buff colour, sprinkled with delicate coffee-coloured rings. These shells are collected and sold for use as shirt-studs.

² *Volva subrostrata* feeds on the branches of *Rhipidigorgia*, Sea-fans. On the common lilac Sea-fan the animal and its shell were lilac; on the yellow variety of the same *Gorgonia*, not only the animal, but also the substance of the shell, was of a yellow colour.

BIVALVES.

<i>Perna tulipa.</i> Lam.	<i>Tellina.</i>
<i>Barbatia fusca.</i> Brug.	<i>Tellinella Antonii.</i> Phil.
<i>Arca tetragona.</i> Poli.	<i>Venus.</i> Sp. ?
<i>Lævicardium serratum.</i> L.	<i>Isognomon serratula.</i> Reeve.
var.	<i>Lucina aurantia.</i> Desh.
<i>Papyridea.</i>	<i>Codakia pecten.</i> Lam.
<i>Fulvia bullata.</i> L. young.	<i>Vola aspersa.</i> Sow.
<i>Avicula ala-perdici.</i> Reeve.	<i>Chama reflexa.</i> Reeve.
<i>Mytilus.</i>	<i>Radula lima.</i> L.
<i>Aulacomya exustus.</i> Lam.	<i>Axinea.</i>
<i>Asaphis deplorata.</i> L.	<i>Pectunculus pecteniformis.</i> Gmel.

LONG KEY ISLAND.

UNIVALVES.

<i>Purpura patula.</i> L.	<i>Tectura cimelita.</i> Reeve.
<i>Thalessa deltoidea.</i> Lam.	<i>leucopleura.</i> Gmel.
† <i>Stramonita fasciata.</i> Reeve.	<i>Emarginula.</i>
<i>Bursa.</i>	<i>Subemarginula depressa.</i> Blainv.
† <i>Lampas rhodostoma.</i> Beck.	<i>Fissurella.</i>
<i>Livona pica.</i> L.	<i>Cremides Barbadosensis.</i> Gmel.
<i>Gibbula dentata.</i> L.	<i>Lucapina cancellata.</i> Soland.
<i>Ruma mamillaris.</i> Born.	<i>viridula.</i> Lam.
<i>Littorina.</i>	<i>Clypidella fascicularis.</i> Lam.
<i>Melaraphe zic-zac.</i> Chem.	<i>Persicula guttata.</i> Link.
<i>Tectarius muricatus.</i> L.	<i>Nassa.</i>
† <i>Antonii.</i> Phil.	† <i>Uzita obtusata.</i> A. Ad.
<i>dilatata.</i> D'Orb.	<i>Columbella mercatoria.</i> L.
<i>Nerita.</i>	<i>Turris.</i> Sp. ?
<i>Pila peloronta.</i> L.	<i>Cerithium eburneum.</i> Brug.
<i>striata.</i> Martyn.	<i>litteratum.</i> Born.
<i>tessellata.</i> Gmel.	<i>Cladopoda.</i> Sp. ?
<i>Neritella.</i>	<i>Pupa mumia.</i> Brug.
<i>Vitta pupa.</i> L.	<i>Cyphoma gibbosa.</i> L.
<i>Tritonium.</i>	
<i>Gutturium tuberosum.</i> Lam.	

BIVALVES.

<i>Barbatia fusca.</i> Brug.	<i>Mytilus.</i>
<i>Arca.</i> Sp. ?	<i>Aulacomya exusta.</i> Lam.

ATHOL ISLAND.

UNIVALVES.

<i>Purpura.</i>	<i>Mamma.</i> Sp. ?
<i>Thalessa deltoidea.</i> Lam.	<i>Drillia.</i>
Sp. ?	<i>Crassispira fucata.</i> Reeve.

- Senectus Malkeanus. *Gmel.*
 Nerita.
 Pila striata. *Martyn.*
 Neritella.
 Vitta Mertoniana. *Recluz, 4 vars.*
 Gibbula dentata. *L.*
 Nassa.
 Hima obtusata. *A. Ad.*
 ambigua. *Pult.*

- Cerithium litteratum. *Born.*
 eburneum. *Brug.*
 Modulus. *Sp.?*
 Littorina.
 Melaraphe carinifera. *D'Orb.*
 Tectarius muricatus. *L.*
 dilatatus. *D'Orb.*
 Pupa marmorata. *Pr.*

Lævicardium serratum. *L.*

BIVALVES.

ABACO.

UNIVALVES.

- Lophyrus squamosus. *L.*
 foveolatus. *Poli.*
 assimilis. *Reeve.*
 Conus.
 Stephanoconus mus. *Hwass.*
 verrucosus. *Hwass*
 Leptoconus flavescens. *Gray*
 Tritonium. *Sp.?*
 Mitra granulosa. *Lam.*
 Dactylus.
 Strephona olivaceus. *Meusch.*
 Olivella parvula. *Martini.*
 oryza. *Lam.*
 Omphalius excavatus. *Lam.*
 maculo-striatus. *C. B. Ad.*
 scalaris. *Anton.*
 Gibbula dentata. *L.*
 Volvaria.
 Volvarina subtriplicata. *D'Orb. var.*
 Mamna mamilla. *L.*
 Natica.
 Stigmaulax sulcata. *Born.*
 Obeliscus terebellum. *Mull.*
 Trivia pediculus. *L.*
 quadripunctata. *Gray.*
 Leucozonia Knorii. *Desh.*
 Fissurella.
 Cremides Barbadosensis. *Gmel.*
 rugosa. *Sow.*
 nodosa. *Born.*
 clathrata. *Reeve.*
 Lucapina cancellata. *Soland.*
 suffusa. *Reeve.*
 minuta. *Sow.*
 viridula. *Lam.*
- Columbella mercatoria. *L.*
 Nitidella nitida. *Lam.*
 Mitrella cribraria. *Lam.*
 Morum oniscus. *L.*
 † Siphonaria cochleariformis. *Reeve.*
 Emarginula.
 Subemarginula depressa. *Blain.*
 polygonata. *Ad.*
 Haminea. *Sp.?*
 Calyptra alveolata. *A. Ad.*
 Cochlelepas imbricata. *Gould.*
 Nassa.
 Hima. *Sp.?*
 Acus hastata. *Gmel.*
 Cladopoda arenaria. *Quoy.*
 Vermetus lumbricalis. *L.*
 Scala.
 Clathrus clathrus. *L.*
 Cerithium ferrugineum. *Say.*
 Littorina
 Melaraphe carinata. *D'Orb.*
 Volva subrostrata. *Sow.*
 Planaxis lineata. *Du Costa.*
 Tectarius dilatata. *D'Orb.*
 Livona pica. *L. var.*
 Cantharus.
 Tritonidea ringens. *Reeve.*
 Neritella.
 Vitta pupa. *L.*
 Nerita.
 Pila peloronta. *L.*
 striata. *Martyn.*
 tessellata. *Gmel.*
 Purpura.
 Thalassa deltoidea. *Lam.*

<i>Clypidella fascicularis.</i> Lam	<i>Stramonita.</i> Sp.?
<i>Tectura cimelita.</i> Reeve.	
<i>leucopleura.</i> Gmel.	
<i>melanoleuca.</i> Gmel.	

LAND SHELLS.

<i>Eurycratera.</i>	<i>Cyclostomus Dominicanensis.</i> Pfeiff.
<i>Polymita varians.</i> Menke.	<i>Pupa mumia.</i> Brug.

BIVALVES.

<i>Barbatia fusca.</i> Brug.	<i>Asaphis deflorata.</i> L.
<i>Acar gradata.</i> Brod.	<i>Tellina radiata.</i> L.
<i>Axinaea.</i> Young.	<i>Radula lima.</i> L.
<i>Chione pygmæa.</i> Lam.	<i>Hemicardia.</i>
<i>Avicula assula.</i> Reeve.	<i>Fragum media.</i> L.
<i>Pecten.</i>	<i>Perna.</i>
<i>Chlamys ornatus.</i> Lam.	<i>Brachydontes subramosa.</i> Han.
<i>Isognomon serratula.</i> Reeve.	<i>Lucina aurantia.</i> Desh.
<i>Ostrea foliacea.</i> L.	<i>Cyclus divaricata.</i> L.

The shells from Abaco were chiefly collected from flat blocks of coral debris, brought to shore from water two or three feet in depth.

SHELLS, presented by F. H. REDFIELD, Esq., Philadelphia.

<i>Erato vitellinus.</i> Hinds.	<i>Eurycratera</i>
	<i>Polymita Brocheri.</i> Gut.

CONCLUDING REMARKS.

Occasionally the same species may be found recorded in several of the lists; for the occurrence of a species in several distinct, though neighbouring, localities, may be a fact at least as suggestive as the finding of a fresh species.

It will be observed how very much the shells of the older conchologists preponderate in the lists.

The foregoing series is simply a small contribution to the materials requisite for the construction of a scheme which shall include the chief facts of the distribution of the West Indian Mollusca. From such a scheme, when it shall be completed, interesting conclusions may, no doubt, be drawn.

LIVERPOOL:
D. MARPLES AND CO., LIMITED,
LORD STREET.

May 1. 1878

PROCEEDINGS

OF THE

LITERARY AND PHILOSOPHICAL SOCIETY

OF

LIVERPOOL,

DURING THE

SIXTY-SIXTH SESSION, 1876-77.

No. XXXI.



LONDON:

LONGMANS, GREEN, READER, & DYER.

LIVERPOOL:

D. MARPLES & CO., LIMITED, LORD STREET.

1877.

THE FOLLOWING MAY BE OBTAINED FROM THE LIBRARIAN

Proceedings, No. I. 1844—45, to Members,	4s. 0d.,	to others,	5s. 0d.
“ II. 1845—46,	“ 2s. 6d.,	“	3s. 6d.
“ III. 1846—47,	“ 2s. 6d.,	“	3s. 6d.
“ IV. 1847—48,	“ 2s. 6d.,	“	3s. 6d.
“ V. 1848—49,	“	Out of Print.	
“ VI. 1849—51,	“ 7s. 6d.,	“	8s. 6d.
“ VII. 1851—53,	“ 6s. 0d.,	“	7s. 0d.
“ VIII. 1853—54,	“ 6s. 0d.,	“	7s. 0d.
“ IX. 1854—55,	“ 3s. 0d.,	“	3s. 6d.
“ X. 1855—56,	“ 3s. 0d.,	“	3s. 6d.
“ XI. 1856—57,	“ 3s. 0d.,	“	3s. 6d.
“ XII. 1857—58,	“ 5s. 6d.,	“	6s. 6d.
“ XIII. 1858—59,	“ 5s. 0d.,	“	6s. 0d.
“ XIV. 1859—60,	“ 6s. 0d.,	“	7s. 0d.
“ XV. 1860—61,	“ 6s. 0d.,	“	7s. 0d.
“ XVI. 1861—62,	“ 6s. 0d.,	“	7s. 0d.
“ XVII. 1862—63,	“ 6s. 6d.,	“	7s. 6d.
“ XVIII. 1863—64,	“ 6s. 6d.,	“	7s. 6d.
“ XIX. 1864—65,	“ 8s. 6d.,	“	9s. 6d.
“ XX. 1865—66,	“ 5s. 6d.,	“	6s. 6d.
“ XXI. 1866—67,	“ 5s. 0d.,	“	6s. 0d.
“ XXII. 1867—68,	“ 5s. 6d.,	“	6s. 6d.
“ XXIII. 1868—69,	“ 8s. 6d.,	“	9s. 6d.
“ XXIV. 1869—70,	“ 5s. 6d.,	“	6s. 6d.
“ XXV. 1870—71,	“ 8s. 0d.,	“	9s. 0d.
“ XXVI. 1871—72, with } Index to Vols. I. to XXV. }	“ 12s. 6d.,	“	13s. 6d.
“ XXVII. 1872—73,	“ 9s. 0d.,	“	10s. 0d.
“ XXVIII. 1873—74,	“ 11s. 6d.,	“	12s. 6d.
“ XXIX. 1874—75,	“ 10s. 6d.,	“	11s. 6d.
“ XXX. 1875—76,	“ 10s. 0d.,	“	11s. 0d.

The Natural History Monographs form Appendices to the following numbers:—

- Nos. VI. & VII.Mr. Hartnup's Local Meteorological Tables.
 Nos. VI. & IX.Dr. Dickinson's Local Flora and Supplement.
 No. VIII.Mr. Byerley's Local Fauna.
 Nos. IX. & XIV.Mr. Marrat's Local Musci, Hepaticæ, &c.
 Nos. XII. & XIII.Rev. H. H. Higgins's Local Fungi.
 No. XVIII.Mr. Brockholes' Lepidoptera of Wirral.

The Society will be happy to exchange "Proceedings" with other publishing bodies.

TOZZER LIBRARY



3 2044 041 998 378

